

## **EMC** EMISSION - TEST REPORT

JQA APPLICATION No. : KL8090482

Name of Product : FRS Transceiver

Model/Type No. : KX-TR325

FCC ID : ACJ96NKX-TR325

Applicant : Kyushu Matsushita Electric Co., Ltd.

Address : 1-62, 4-chome, Minoshima, Hakata-ku, Fukuoka 812-8531, Japan

Manufacturer : Kyushu Matsushita Electric Co., Ltd.

Address : 1-62, 4-chome, Minoshima, Hakata-ku, Fukuoka 812-8531, Japan

**Final Judgement** : **Passed**

**TEST RESULTS IN THIS REPORT** are obtained in use of equipment that is traceable to Electro-technical Lab. of MITI Japan and Communications Research Lab. of PTT Japan.

**THE TEST RESULTS** only responds to the test sample. This test report shall not be reproduced except in full.

JAPAN QUALITY ASSURANCE ORGANIZATION (JQA)  
KITA-KANSAI TESTING CENTER  
EMC DIVISION

## DIRECTORY

	<b>Page</b>
<b>A) Documentation</b>	
Directory	<u>2</u>
Test Regulation / General Information	<u>3 - 4</u>
Test Conditions	<u>5 - 19</u>
Configuration of TUT / Operation mode of the TUT	<u>20 - 21</u>
TUT Modification / Responsible Party	<u>22</u>
Test results / Measurement Uncertainty	<u>23 - 25</u>
Summary	<u>26</u>
<b>Test System-Arrangement (Drawings)</b>	<u>27</u>
<b>Test-setup (Photographs) at worst case</b>	<u>28</u>
<b>B) Test data</b>	
Transmitter Power(TP)	<u>29</u>
Maximum Transmitter Power(ERP)	<u>30</u>
Antenna gain of the integrated transmitter antenna of the TUT	<u>31</u>
Modulation Characteristics	<u>32 - 40</u>
Occupied Bandwidth	<u>41 - 55</u>
Unwanted Radiation	<u>56 -59</u>
Frequency Stability	<u>60 - 62</u>

### TEST REGULATION

FCC Rules and Regulations Part 95 (October 1, 1998)

- General Mobile Radio Service(GMRS)
- Family Radio Service(FRS)
- Radio Control(R/C) Radio Service
- Citizen Band(CB) Radio Service
- Interactive Video and Data Service(IVDS)
- Low Power Radio Service(LPRS)

#### **Test procedure:**

The tests were performed according to FCC Rules and Regulations Part 2 (October 1, 1998).

### GENERAL INFORMATION

#### **Test facility:**

- 1) Test Facility located at Kita-Kansai : 1st and 2nd Open Sites (3 m Site)  
Test Facility located at Kameoka Open Site (3, 10 and 30 m, on common plane)  
**FCC filing No. : 31040/SIT 1300F2**
- 2) KITA-KANSAI TESTING CENTER is recognized under the National Voluntary Laboratory Accreditation Program for satisfactory compliance established in Title 15, Part 285 Code of Federal Regulations.  
**NVLAP Lab Code: 200191-0**

**Description of the Transmitter Under Test (TUT):**

- 1) Name : FRS Transceiver
- 2) Model/Type No. : KX-TR325
- 3) Product Type : Pre-Production
- 4) Category : Family Radio Service(FRS)
- 5) TUT Authorization : ○ - Verification ● - Certification ○ - D.o.C.
- 6) Transmitting Frequency : 462.5625 MHz(1 ch) - 462.7125 MHz(7 ch)  
467.5625 MHz(8 ch) - 467.7125 MHz(14 ch)
- 7) Receiving Frequency : 462.5625 MHz(1 ch) - 462.7125 MHz(7 ch)  
467.5625 MHz(8 ch) - 467.7125 MHz(14 ch)
- 8) Integrated Antenna Polarized : Rotating Antenna to upright position(vertically polarized)  
before pressing "TALK BUTTON".
- 9) Emission Designations : 9K40F3E
- 10) Maximum power rating specified : 0.5 W (ERP)
- 11) Power Rating : DC 4.5 V (Alkaline Battery AA × 3)  
Cigar Lighter Adaptor DC 13.2 V(11.22 V - 15.18 V)  
/Output 4.5 V

**Definitions for symbols used in this test report:**

- - Black box indicates that the listed condition, standard or equipment is applicable for this Report.
- - Blank box indicates that the listed condition, standard or equipment is not applicable for this Report.

## TEST CONDITIONS

### **Transmitter Power(TP) Measurement (§2.1046(a))**

The Transmitter Power was measured with a power meter, a 20 dB attenuator and a short, low loss cable.

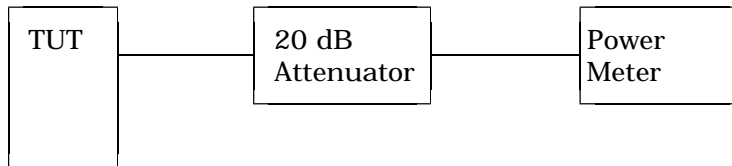

### **Test location:**

KITA-KANSAI Testing Center

7-7, Ishimaru, 1-Chome, Mino-Shi, Osaka, 562-0027, Japan

● - Shielded room

KAMEOKA EMC Branch

9-1, Ozaki, Inukanno, Nishibetsuin-Cho, Kameoka-Shi, Kyoto, 621-0126, Japan

○ - Shielded room

### **Used test instruments and sites:**

Model No.	Device ID	Last Cal. Date	Cal. Interval
● - 432B/8478B	B - 24/B-43	March, 1999	1 Year
● - 6-20	D - 27	November, 1998	1 Year
○ - 8566B	A - 13		
○ - 8593A	A - 15		

### **Environmental conditions:**

Temperature: 24 °C      Humidity: 46 %

**Maximum Transmitter Power(ERP) Measurement and Antenna gain measurement of the integrated transmitter antenna of the TUT(\$95.639(d),95.647)**

The measurement were performed shown as follows.

Step 1) The test was set-up shown as Fig.1(a). In order to obtain the maximum emission, the TUT is placed at the height 0.8m on the wooden table, at the distance 3m from the receiving antenna(Resonant Tune Dipole Antenna) and rotated around 360 degrees. The receiving antenna height was varied from 1m to 4 m . The TUT on the table was placed to be maximum emission against the receiving antenna polarized (Vertical and Horizontal). Then the meter reading of the test receiver at the maximum emission was A dB( $\mu$ V).

Step 2) The test was set-up shown as Fig.1(b). The TUT was replaced to half-wave dipole antenna at the same polarized under the same condition as step 1. The RF power was fed to the transmitting Antenna(half-wave Dipole Antenna) through the RF amplifier from the signal generator. In order to obtain the maximum emission level, the height is varied from 1m to 4 m. The level of the signal generator was adjusted so that the meter reading of the test receiver at the maximum emission was A dB( $\mu$ V) ,same as the recorded level in Step1. Then the RF power into the substitution half-wave dipole antenna was P(dBm).

The ERP is calculated in the following equation.

$$ERP[dBm] = P (dBm)- ( Balun Loss of the half-dipole Ant. (dB) )$$

Step 3) Calculation of the antenna gain of the integrated antenna of the TUT

$$TP + G_{tut} = ERP + G_d \text{ --- (1)}$$

$$G_{tut} - G_d = ERP - TP \text{ ---(2)}$$

Where Antenna gain of the integrated antenna of the TUT :  $G_{tut}(dB)$   
Antenna gain of the half-wave dipole antenna :  $G_d(dB) = 2.15 (dB)$   
Transmitter power :  $TP(dBm)$   
Effective Radiated Power :  $ERP(dBm)$

Note) Transmitter Power(TP) is directly measured by power meter at RF output terminal of the TUT as shown at page 5.

If the antenna gain( $G_{tut}$ ) is met equation (4) as follows.

$$G_{tut} - G_d = ERP - TP < 0 \text{ ---(3)}$$

$$ERP < TP \text{ ---(4)}$$

Therefore if the relation between ERP and TP is met the equation(4), the antenna gain( $G_{tut}$ ) is regarded as no gain(as compared to a half-wave dipole).

**Test location:**

**KITA-KANSAI Testing Center**

7-7, Ishimaru, 1-Chome, Mino-Shi, Osaka, 562-0027, Japan

● - 1st site (3 meters)

○ - 2nd site (3 meters)

**KAMEOKA EMC Branch**

9-1, Ozaki, Inukanno, Nishibetsuin-Cho, Kameoka-Shi, Kyoto, 621-0126, Japan

○ - 3 meters

○ - 10 meters

**Validation of Site Attenuation:**

1) Last Confirmed Date : November 27, 1998

2) Interval : 1 Year

**Used test instruments:**

Model No.	Device ID	Last Cal. Date	Cal. Interval
● - ESV	A - 7	December, 1998	1 Year
○ - ESV/ESV-Z3	A - 6 / A - 18		
○ - ESV/ESV-Z3	A - 4 / A - 20		
○ - ESV/ESV-Z3	A - 8 / A - 19		
● - 4396B	B - 47	July, 1999	1 Year
○ - 8566B	A - 13		
○ - 8593A	A - 15		
● - KBA-511A	C - 12	November, 1998	1 Year
○ - KBA-611	C - 22		
● - KBA-511A	C - 13	November, 1998	1 Year
○ - KBA-611	C - 19		
○ - KBA-511A	C - 11		
○ - KBA-611	C - 21		
○ - Cable	H - 1		
○ - Cable	H - 2		
● - Cable	H - 5	November, 1998	1 Year
○ - Cable	H - 6		
● - DC6180	E - 51	December, 1998	1 Year
● - 8673D	B - 2	April, 1999	1 Year
● - A1000-100S	A - 29	December, 1998	1 Year

**Environmental conditions:**

Temperature: 18 °C Humidity: 50 %

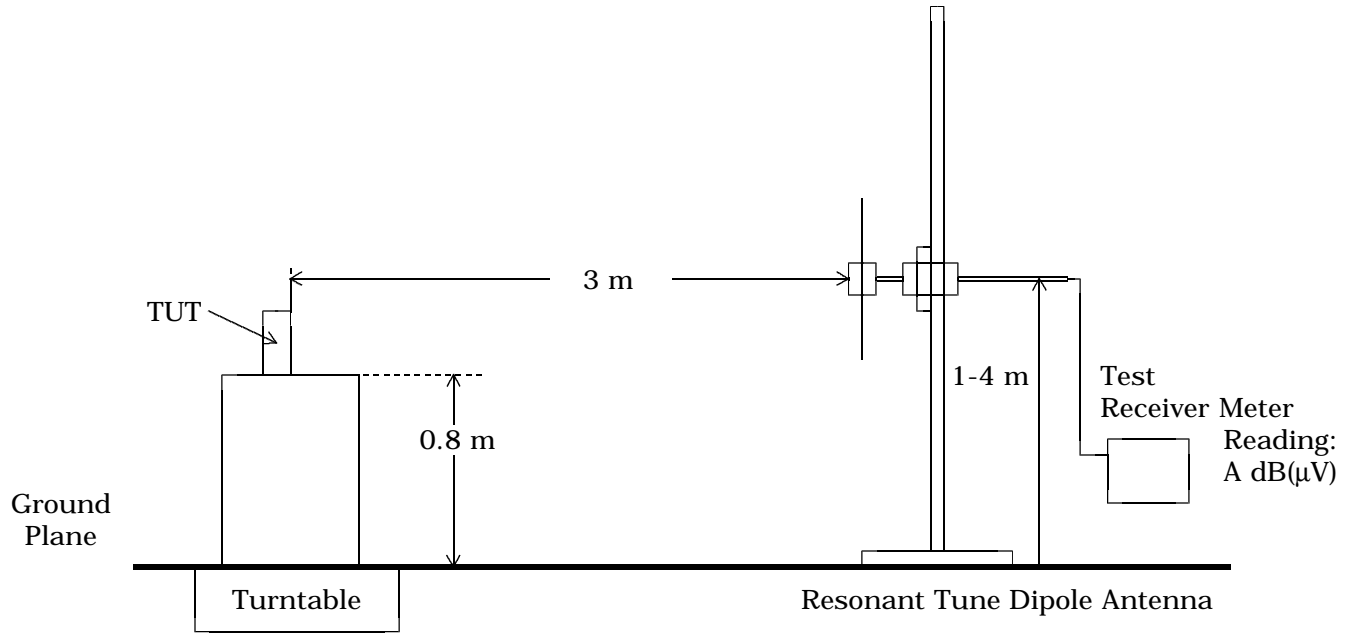

(a) TUE

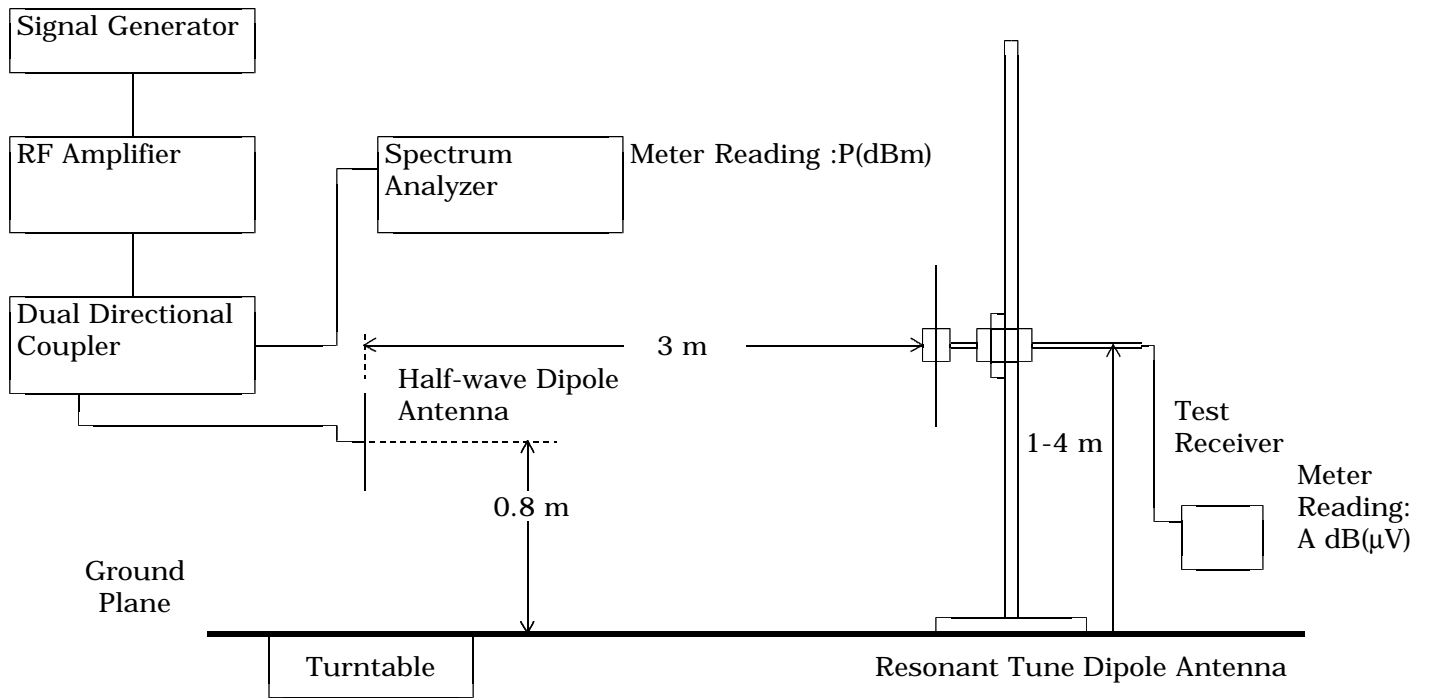

(b) Half-wave Dipole Antenna

Fig.1 Maximum Transmitter Power(ERP) Measurement

### **Modulation Characteristics Measurement(§2.1047(a)(b))**

a) Modulation frequency response measurement(§95.637(a))

In order to check the audio frequency response of the audio signal input level versus the audio frequency under the constant frequency deviation( $\pm 1$ kHz), the audio signal generator was connected to the microphone input terminal of the TUT. The maximum point was taken as reference level, 0 dB. The linear FM detector was connected to the RF antenna terminal of the TUT. The frequency of the input signal was increased from 100 Hz to 10 kHz and the modulation frequency response was plotted out.

b) Modulation limiting capability response measurement(§95.637(a))

The modulation response was measured to the maximum frequency deviation for each of tones: 2500 Hz, frequency of maximum response, 2000 Hz and 3000 Hz. The audio input level was increased from 10% modulation up to approximately 50 dB level than the saturation point. The measurements were performed in both minus and plus modulations and the respective results were plotted out.

c) Audio low-pass filter frequency response measurement(§95.637(a)(b))

The tracking generator was connected to the input of the low-pass filter under test. The filter audio response was measured from 500 Hz to 30 kHz. and 1 kHz point was taken as 0 dB reference level. The relative level to 1 kHz was plotted over this frequency range.

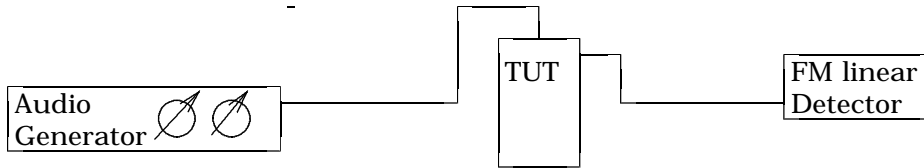

(a) Modulation frequency response and Modulation limiting capability response measurements

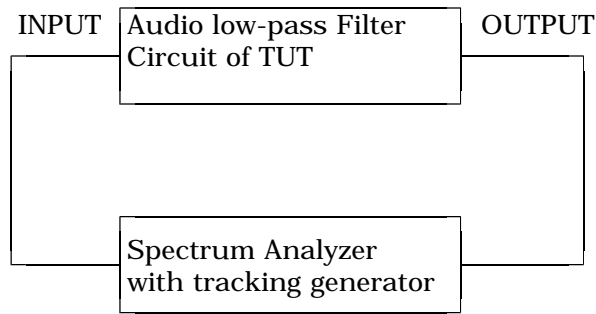

Setting of Spectrum Analyzer RES BW : 30 Hz  
VIDEO BW : 30 Hz

(b) Audio low-pass filter frequency response measurements

**Test location:**

KITA-KANSAI Testing Center

7-7, Ishimaru, 1-Chome, Mino-Shi, Osaka, 562-0027, Japan

● - Shielded room

KAMEOKA EMC Branch

9-1, Ozaki, Inukanno, Nishibetsuin-Cho, Kameoka-Shi, Kyoto, 621-0126, Japan

○ - Shielded room

**Used test instruments and sites:**

Model No.	Device ID	Last Cal. Date	Cal. Interval
● - 3585A	12202019	May, 1999	1 Year
● - VP-7212A	B-41	November, 1998	1 Year

**Environmental conditions:**

Temperature: 24 °C Humidity: 50 %

**Occupied Bandwidth Measurement (§2.1049(c)(1), §95.635(a)(b))**

- 1) The TUT was terminated at a 50-ohms input of a spectrum analyzer. The wave shape was captured in trace using a Resolution Bandwidth (RES BW) of 0.3 kHz, a Video Bandwidth (VIDEO BW) of 1 kHz and a frequency span (SPAN) of 100 kHz. The peak level at unmodulation emission was adjusted to be equal to the reference level.
- 2) The measurement of the occupied bandwidth were made under the following modulation conditions of the TUT.
  - a) Internal Signal  
 The TUT has 38 internal tone signals (67.0 Hz - 250.3 Hz).
  - b) External Audio Signal  
 The occupied bandwidth with measurement was made under by the modulation of a 2500 Hz tone, an input level 16 dB greater than that necessary to produce 50% modulation. The input level is established at the frequency of the maximum response of the audio modulating circuit. Refer to b) in page 9.

**Widespread Emission Measurement (§2.1049(c)(1), §95.635(a)(b))**

The widespread emission measurement was performed under the modulated condition of the worst result of the occupied bandwidth measurement. The wave shape was captured in trace using a Resolution Bandwidth (RES BW) of 1 kHz, a Video Bandwidth (VIDEO BW) of 3 kHz and a frequency span (SPAN) of 500 kHz. The peak level at unmodulation emission was adjusted to be equal to the reference level.

**Band-edge Emission Measurement (§2.1049(c)(1), §95.635(a)(b))**

The Band-edge emission measurement was performed under the modulated condition of the worst result of the occupied bandwidth measurement. The wave shape was captured in trace using a Resolution Bandwidth (RES BW) of 1 kHz, a Video Bandwidth (VIDEO BW) of 3 kHz, a frequency span (SPAN) of 500 kHz and a center frequency of the band-edge frequency against the each channel. The peak level at unmodulation emission was adjusted to be equal to the reference level.

Transmitting Frequency (MHz)	Band-edge Frequency (§2.106) (MHz)
462.5625	462.5375
462.7125	462.7375
467.5625	467.5375
467.7125	467.7375

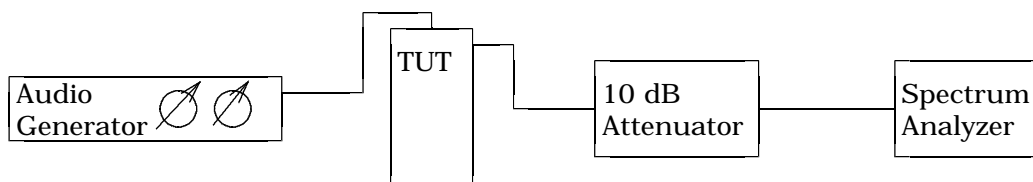

**Test location:**

KITA-KANSAI Testing Center

7-7, Ishimaru, 1-Chome, Mino-Shi, Osaka, 562-0027, Japan

● - Shielded room

KAMEOKA EMC Branch

9-1, Ozaki, Inukanno, Nishibetsuin-Cho, Kameoka-Shi, Kyoto, 621-0126, Japan

○ - Shielded room

**Used test instruments and sites:**

Model No.	Device ID	Last Cal. Date	Cal. Interval
○ - 4396B	B - 47		
● - 8566B	A - 13	October, 1998	1 Year
○ - 8593A	A - 15		
● - 2-10	D - 40	July, 1999	1 Year
● - VP-7212A	B-41	November, 1998	1 Year

**Environmental conditions:**

Temperature: 24 °C Humidity: 50 %

### **Unwanted Radiation Measurement (§2.1053,§95.635(a)(b))**

The ERP of the transmitter spurious radiation were measured at the distance 3m away from the TUT which was placed on a wooden table 0.8m in height and was varying at three orthogonal axes. The receiving antenna was oriented for vertical polarization and varied from 1 m to 4 m until the maximum emission level was detected on the measuring instrument. The TUT was rotated 360 degrees until the maximum emission was received. The measurement was repeated with the receiving antenna in the horizontal polarization.

The TUT was removed and replaced with a half-wave dipole antenna. The center of the half-wave dipole antenna was placed at the same location of the TUT.(In the case of the lower frequencies, where the half-wave dipole antenna is polarized vertically. In such a case the lower end of the antenna was adjusted to one foot above the ground). The RF power was fed to the transmitting antenna(half-wave dipole antenna) from a signal generator, and the RF output level of the signal generator was adjusted to obtain the previously recorded maximum reading at the particular spurious emissions frequency and recorded. This procedure was repeated with the receiving antenna and the half-wave dipole antenna in the orthogonal polarization.

The ERP into the half-wave dipole antenna was calculated by these readings. The level of the spurious emission (ERP in dBm) was compared with the fundamental frequency transmitter power by specified attenuation limits,  $43+10\log_{10}(TP \text{ in watt})$ .

#### Transmitter Test Condition:

The test was made under such transmitting operation as simulating the typical fashion with the integrated antenna .

The radiation measurements were made both conditions without accessories and with optional accessories of the TUT.

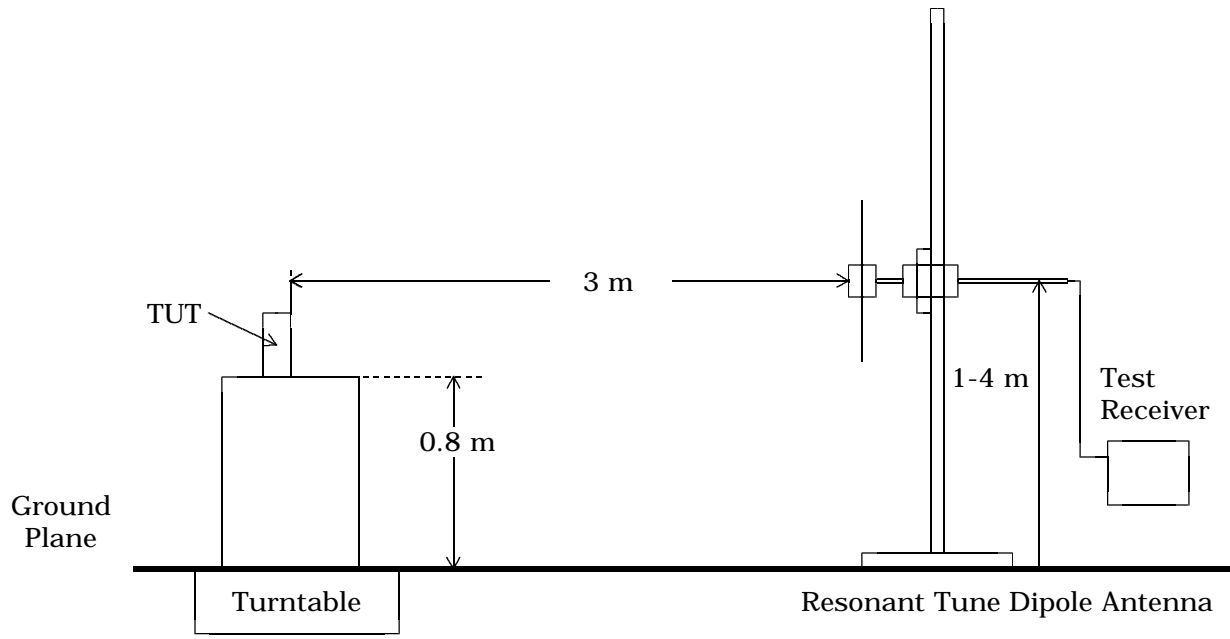

(a) Measurement Set Up for up to 1GHz

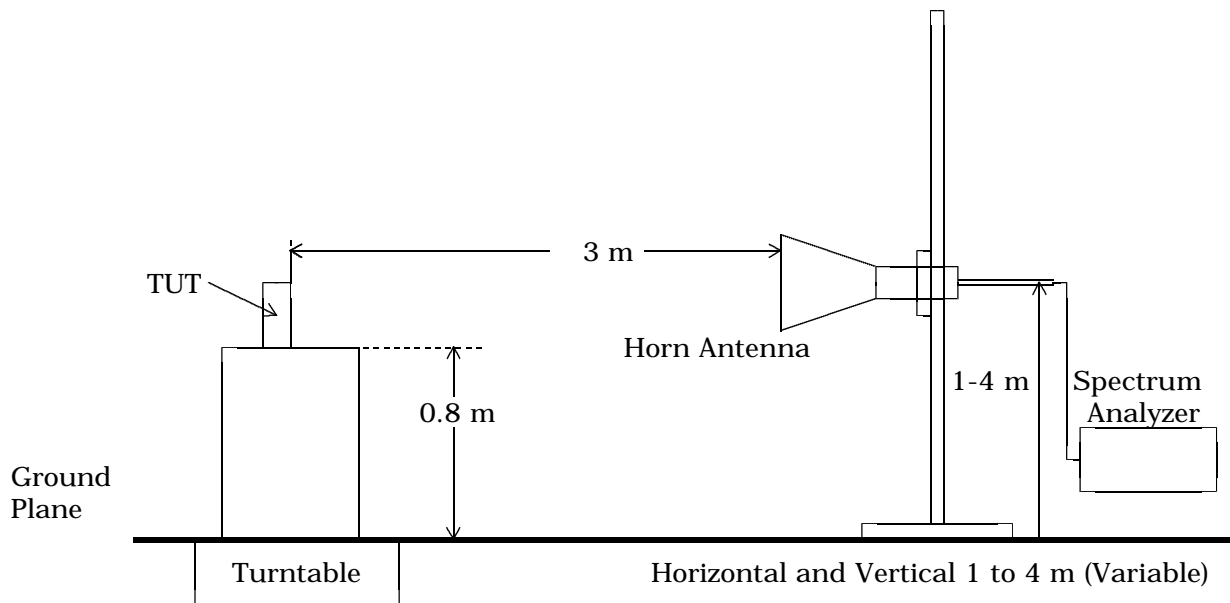

(b) Measurement Set Up for above 1GHz

Fig.2 Unwanted Radiation Measurement

**Test location:**

**KITA-KANSAI Testing Center**

7-7, Ishimaru, 1-Chome, Mino-Shi, Osaka, 562-0027, Japan

● - 1st site (3 meters)

○ - 2nd site (3 meters)

**KAMEOKA EMC Branch**

9-1, Ozaki, Inukanno, Nishibetsuin-Cho, Kameoka-Shi, Kyoto, 621-0126, Japan

○ - 3 meters

○ - 10 meters

**Validation of Site Attenuation:**

1) Last Confirmed Date : November 27, 1998

2) Interval : 1 Year

**Used test instruments:**

Model No.	Device ID	Last Cal. Date	Cal. Interval
● - ESV	A - 7	December, 1998	1 Year
○ - ESV/ESV-Z3	A - 6 / A - 18		
○ - 4396B	B - 47		
● - 8566B	A - 13	October, 1998	1 Year
○ - 8593A	A - 15		
● - KBA-511A	C - 12	November, 1998	1 Year
● - KBA-511A	C - 13	November, 1998	1 Year
○ - Cable	H - 1		
○ - Cable	H - 2		
● - Cable	H - 5	November, 1998	1 Year
○ - Cable	H - 6		
● - 8673D	B - 2	April, 1999	1 Year
● - DC6180	E - 51	December, 1998	1 Year
● - 4T-10	D - 73	May, 1999	1 Year
● - 4T-10	D - 74	May, 1999	1 Year
○ - WJ-6611-513	A - 23		
● - WJ-6882-824	A - 21	May, 1999	1 Year
○ - DBL-0618N515	A - 33		

- continue -

**Used test instruments:**

Model No.	Device ID	Last Cal. Date	Cal. Interval
● - 91888-2	C - 41 - 1	May, 1999	1 Year
● - 91889-2	C - 41 - 2	May, 1999	1 Year
○ - 94613-1	C - 41 - 3		
○ - 91891-2	C - 41 - 4		
○ - 94614-1	C - 41 - 5		
● - 91888-2	C - 40 - 1	May, 1999	1 Year
● - 91889-2	C - 40 - 2	May, 1999	1 Year
● - 94613-1	C - 40 - 3	May, 1999	1 Year
● - 3160-04	C - 55	June, 1999	1 Year
● - 3160-05	C - 56	June, 1999	1 Year
○ - 3160-09	C - 48		
○ - TRA-603D	D - 24		
○ - 8494H/8595H	D - 76		
○ - MZ5010C	D - 81		
● - Cable	C - 40 - 11	May, 1999	1 Year
● - Cable	C - 40 - 12	May, 1999	1 Year

**Environmental conditions:**

Temperature: 18 °C Humidity: 50 %

**Frequency Stability Measurement(\$2.1055, §95.627(b))**

a) Frequency Stability Measurement versus Temperature

The TUT was placed in an environmental chamber and was tested in the range of -20 to +50 degrees Celsius. The TUT was stabilized at each temperature. The power(DC4.5V) was applied to the transmitter and allowed to stabilize for 2 minutes. The transmitting frequency was measured at startup and two minutes after startup. This procedure was repeated for each 10 degrees step up to +50 degrees Celsius.

b) Frequency Stability Measurement versus Power Supply Voltage

The TUT was placed in an environmental chamber and was tested at the temperature of +20 degrees Celsius. The TUT was stabilized at the temperature. The power(DC3.3V) which is reduced to the battery operating end point specified by manufacturer was applied to the transmitter and allowed to stabilize for 2 minutes. The transmitting frequency was measured at startup and two minutes after startup. But the measurement with the cigar lighter adaptor including a DC regulator(DC4.5V constant for primary variation) was not performed.

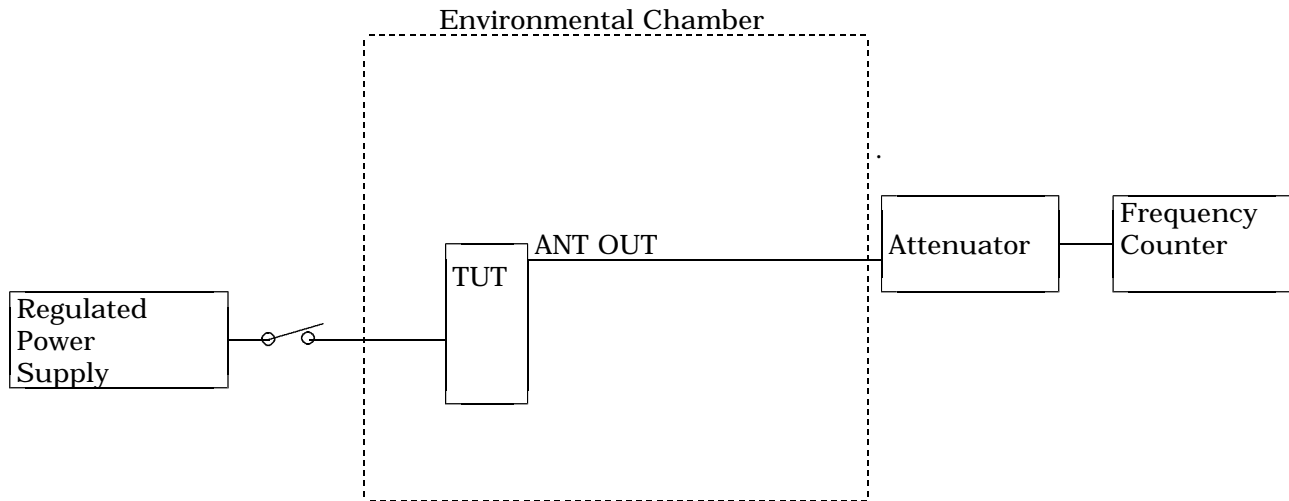

**Test location:**

KITA-KANSAI Testing Center

7-7, Ishimaru, 1-Chome, Mino-Shi, Osaka, 562-0027, Japan

○ - Shielded room

● - Environment Testing Room

KAMEOKA EMC Branch

9-1, Ozaki, Inukanno, Nishibetsuin-Cho, Kameoka-Shi, Kyoto, 621-0126, Japan

○ - Shielded room

**Used test instruments and sites:**

Model No.	Device ID	Last Cal. Date	Cal. Interval
● - PL-3G	02304009	December, 1998	1 Year
● - EL100-06-T4	14201089	December, 1998	1 Year
● - 2011-39	B - 33	April, 1999	1 Year
● - 6032A	F - 5	April, 1999	1 Year
● - TR5212	B - 30	March, 1999	1 Year

### CONFIGURATION OF TUT

**The Transmitter Under Test (TUT) consists of:**

Description	Applicant (Manufacturer)	Model No. (Serial No.)	FCC ID
FRS Transceiver	Kyushu Matsushita Electric Co., Ltd. (Kyushu Matsushita Electric Co., Ltd.)	KX-TR325 (---)	ACJ96NKX-TR325

**The measurement was carried out with the following equipment connected:**

Description	Grantee/Distributor	Model No. (Serial No.)	FCC ID
Cigar Lighter Adaptor	Kyushu Matsushita Electric Co., Ltd.	KX-TRA20 (---)	N/A
Speaker Mic	Kyushu Matsushita Electric Co., Ltd.	KX-TRA15 (---)	N/A
Headset Mic	Kyushu Matsushita Electric Co., Ltd.	KX-TRA10 (---)	N/A
Earbud Mic	Kyushu Matsushita Electric Co., Ltd.	KX-TRA17 (---)	N/A
DC Power Supply	KIKUSUI ELECTRIC CORP.	PAB 18-1.8 (---)	N/A

**Type of Interference Cable(s) and the AC Power Cord used with the TUT:**

No.	Cable	Shielded	Ferrite Core	Length
1	DC Power Cord(Cigar Lighter Adaptor)	NO	NO	0.7 m
2	Speaker/Mic Cable(Speaker Mic)	NO	NO	0.45m
3	Speaker/Mic Cable(Headset Mic)	NO	NO	1.5 m
4	Speaker/Mic Cable(Earbud)	NO	NO	1.0 m
5	DC Power Cord(DC Power Supply/TUT)	NO	NO	1.0 m
6	AC Power Cord(DC Power Supply) with 2-pin plug	NO	NO	2.2 m

### **Operation - mode of the TUT:**

The TUT was operated during the test under the following specification:

- 1) Occupied Bandwidth measurement
  - a) Internal Signal  
The TUT has 38 internal tone signals(67.0 Hz - 250.3 Hz).
  - b) External Audio Signal  
Inputting at 2.5 kHz sine wave from a microphone.
- 2) Other measurements  
Transmitting

### **Test system:**

The TUT has two ports, one MIC/SP jack and one Cigar lighter jack.

### **Special accessories:**

None

### **Detailed Transmitter port:**

Transmitting frequency : 462.5625 MHz(1ch) - 462.7125 MHz(7ch)  
467.5625 MHz(8ch) - 467.7125 MHz(14ch)

### **Detailed Receiver port:**

Receiving frequency : 462.5625 MHz(1ch) - 462.7125 MHz(7ch)  
467.5625 MHz(8ch) - 467.7125 MHz(14ch)

Local frequency : 441.2625 MHz(1ch) - 441.4125 MHz(7ch)  
446.2625 MHz(8ch) - 446.4125 MHz(14ch)

Intermediate frequency : 21.300 MHz

### **Other Clock Frequency:**

PLL : 21.25 MHz  
CPU, CTCSS : 3.6864 MHz

**TUT Modification**

- - No modifications were conducted by JQA to achieve compliance to applied levels.
- - To achieve compliance to applied levels, the following change(s) were made by JQA during the compliance test.

The modification(s) will be implemented in all production models of this Transmitter

Applicant :  N/A  Date : N/A

Typed Name : N/A Position : N/A

**Responsible Party**

Responsible Party of Test Item(Product)

Responsible party :

Contact Person :

\_\_\_\_\_  
Signatory

**TEST RESULTS**

**Transmitter Power(TP)**

The transmitter power is 0.479 W at 462.6375 MHz  
Uncertainty of measurement results +0.35 dB(2σ) -0.35 dB(2σ)

Remarks: \_\_\_\_\_  
\_\_\_\_\_

**Maximum Transmitter Power(ERP)**

The requirements are ● - Passed ○ - Not Passed  
The Maximum Transmitter (ERP) is 0.398 W at 462.6375 MHz  
Min. limit margin 1.0 dB at 462.6375 MHz  
Max. limit exceeding \_\_\_\_\_ dB at \_\_\_\_\_ MHz  
Uncertainty of measurement results +0.68 dB(2σ) -0.68 dB(2σ)

Remarks: \_\_\_\_\_  
\_\_\_\_\_

**Antenna gain of the integrated transmitter antenna of the TUT**

The requirements are ● - Passed ○ - Not Passed  
Integrated antenna gain of TUT : 1.35 dB at 462.6375 MHz  
Min. limit margin 0.8 dB at 462.6375 MHz  
Max. limit exceeding \_\_\_\_\_ dB at \_\_\_\_\_ MHz  
Uncertainty of measurement results +0.35 dB(2σ) -0.35 dB(2σ)

Remarks: \_\_\_\_\_  
\_\_\_\_\_

**Modulation Frequency Response**

The requirements are **● - Passed** **○ - Not Passed**  
The results Refer to page 33  
Uncertainty of measurement results(FM linear detector) ±3.00 %(2σ)

**Remarks:** \_\_\_\_\_  
\_\_\_\_\_

**Modulation Limiting Capability Frequency Response**

The requirements are **● - Passed** **○ - Not Passed**  
The results Refer to pages 34 - 39  
Necessary Bandwidth(2M+2D) 9400 Hz  
Uncertainty of measurement results(FM linear detector) ±3.00 %(2σ)

**Remarks:** \_\_\_\_\_  
\_\_\_\_\_

**Audio low-pass filter Frequency Response**

The requirements are **● - Passed** **○ - Not Passed**  
The results Refer to page 40  
Uncertainty of measurement results(Spectrum analyzer) ±0.4 dB(2σ)

**Remarks:** \_\_\_\_\_  
\_\_\_\_\_

**Occupied Bandwidth**

The requirements are **● - Passed**      ○ - Not Passed

The results(Occupied Bandwidth) Refer to pages 42 - 49  
The results(Widespread Emission) Refer to pages 50 - 51  
The results(Band-edge Emission) Refer to pages 52 - 55

Uncertainty of measurement results at Frequency ± 0.05 ppm(2σ)  
Uncertainty of measurement results at Amplitude ± 0.35 dB(2σ)

Remarks: \_\_\_\_\_  
\_\_\_\_\_

**Unwanted Radiation ( 3.6864 MHz - 5 GHz)**

The requirements are **● - Passed**      ○ - Not Passed

Min. limit margin 6.5 dB at 1402.9 MHz

Max. limit exceeding \_\_\_\_\_ dB at \_\_\_\_\_ MHz

Uncertainty of measurement results 30 MHz - 1 GHz +0.68 dB(2σ) -0.68 dB(2σ)  
1 GHz - 18 GHz +0.34 dB(2σ) -0.34 dB(2σ)

Remarks: \_\_\_\_\_  
\_\_\_\_\_

**Frequency Stability**

The requirements are **● - Passed**      ○ - Not Passed

Min. limit margin 0.94 ppm at 462.6375 MHz

Max. limit exceeding \_\_\_\_\_ ppm at \_\_\_\_\_ MHz

Uncertainty of measurement results ±0.05 ppm

Remarks: \_\_\_\_\_  
\_\_\_\_\_

**SUMMARY**

**GENERAL REMARKS :**

The TUT was tested according to the requirements of FCC Rules and Regulations Part 95 (October 1, 1998) under the test configuration, as shown in page 27.

The conclusion for the test items of which are required by the applied regulation is indicated under the final judgement.

**FINAL JUDGEMENT :**

The "as received" sample;

- - fulfill the test requirements of the regulation mentioned on page 3.
- - fulfill the test requirements of the regulation mentioned on page 3, but with certain qualifications.
- - doesn't fulfill the test regulation mentioned on page 3.

Begin of testing : October 26, 1999

End of testing : October 30, 1999

- JAPAN QUALITY ASSURANCE ORGANIZATION -

Approved Signatory :



Takashi Yamanaka  
Manager  
EMC Div.  
JQA KITA-KANSAI Testing Center



Akio Hosoda  
Project Manager  
EMC Div.  
JQA KITA-KANSAI Testing Center

**Test System-Arrangement (Drawings)**

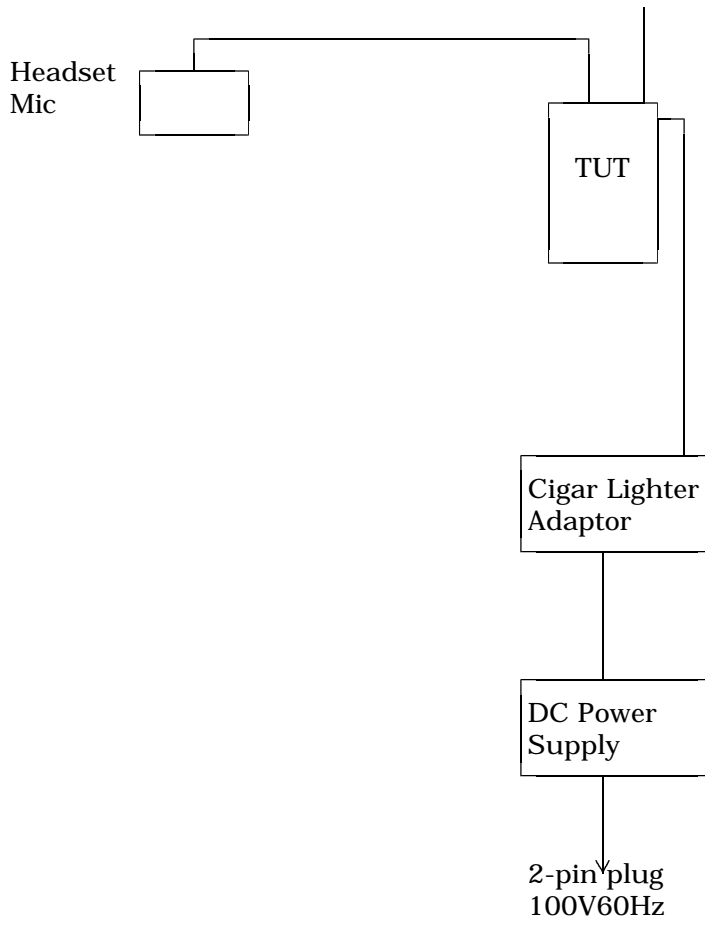

**Test-Setup (Photographs) at worst case**

Radiated Emission



Close-up View



Front View

### Transmitter Power(TP) Measurement

Test Date: October 26, 1999  
Temp.: 24 °C ; Humi.: 46 %

Measurement Results:

Frequency Range : 462.5625 MHz - 467.7175 MHz

Frequency (MHz)	Transmitter Power(TP) (W)
462.6375	0.479
467.6375	0.437

Tester Signature : 

Type Name : Akio Hosoda

Maximum Transmitter Power(ERP) Measurement and Antenna gain measurement  
 of the integrated transmitter antenna of the TUT

Test Date: October 29, 1999  
 Temp.: 18 °C ; Humi.: 50 %

Measurement Results:

Frequency Range : 462.5625 MHz - 467.7175 MHz

Frequency (MHz)	Maximum Transmitter Power ERP(W)		Limits (W)	Margin (dB)
	Hori.	Vert.		
462.6375	0.380	0.398	0.5	+ 1.0
467.6375	0.309	0.309	0.5	+ 2.1

Note : At the calculation of the ERP, the balun loss of the half-wave dipole antenna is considered.

Refer to pages 56 and 58.  
 Sample of calculated result at 462.6375 MHz, as the Minimum Margin point:

Correction Factor	=	61.7 dB
+ Meter Reading	=	-35.7 dBm
Result	=	26.0 dBm

Minimum Margin : 27.0 - 26.0 = 1.0(dB)  
 The point shown on "\_\_\_" is the Minimum Margin Point.

-continue-

Where Antenna gain of the integrated antenna of the TUT : Gtut(dB)  
 Antenna gain of the half-wave dipole antenna : Gd(dB) = 2.15 (dB)  
 Transmitter power : TP(dBm)  
 Effective Radiated Power : ERP(dBm)

If the antenna gain(Gtut) is met the equations as follows.

$$G_{tut} - G_d = ERP - TP < 0$$

$$G_{tut} = G_d + ERP - TP$$

Frequency (MHz)	ERP (W)	TP (W)	Limits (dB)	Gtut (dB)	Margin (dB)
462.6375	0.398	0.479	2.15	+ 1.35	+0.80
467.6375	0.309	0.437	2.15	+ 0.64	+1.51

Sample of calculated result at 462.6375 MHz, as the Minimum Margin point:

Gd = 2.15 dB  
 ERP = 26.00 dBm =  $10\log_{10}(398)$   
 +) -TP = -26.80 dBm =  $10\log_{10}(479)$   
 Result = 1.35 dBm

Minimum Margin :  $2.15 - 1.35 = 0.80(\text{dB})$

The point shown on "\_\_\_" is the Minimum Margin Point.

Tester Signature :

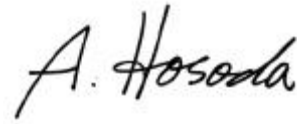

Type Name : Akio Hosoda

## Modulation Characteristics Measurement

Test Date: October 28, 1999  
Temp.: 24 °C ; Humi.: 50 %

a) Modulation frequency response measurement

Measurement Results:

Attached Graph : Refer to page 33.  
Maximum Response Frequency : 2.5 kHz - 2.6 kHz

b) Modulation limiting capability frequency response measurement

Measurement Results:

Attached Graph : Refer to pages 34 - 39.  
Audio input level at 50% modulation of the maximum response frequency(2.5 kHz) : -62.0 dBV

Calculation of Necessary Bandwidth Bn

$$\begin{aligned} B_n &= 2M + 2D \\ M &= \text{Maximum Modulation Frequency} = +2200 \text{ Hz or } -2200 \text{ Hz} \\ D &= \text{Peak Frequency Deviation} = 2500 \text{ Hz} \\ B_n &= 9400 \text{ Hz} \end{aligned}$$

c) Audio low-pass filter frequency response measurement

Measurement Results:

Attached Graph : Refer to page 40.

Tester Signature : 

Type Name : Akio Hosoda

### Audio Frequency Response FCC ID: ACJ96NKX-TR325

Model No. : KX-TR325 Freq. Deviation: 1KHz Odb= .76mV

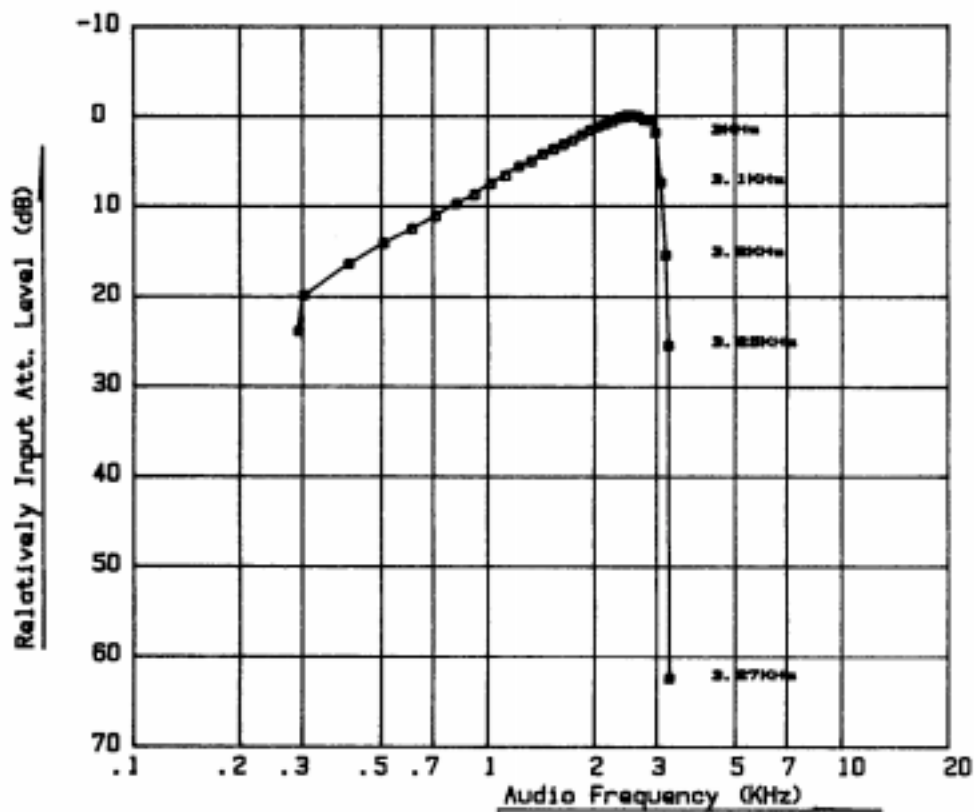

### Modulation Characteristics FCC ID: ACJ96NKX-TR325

Model No. : KX-TR325 1V=0dB at 2KHz Deviation : PLUS

Max Deviation : 2.2KHz 50% Modulation Level : -62dB

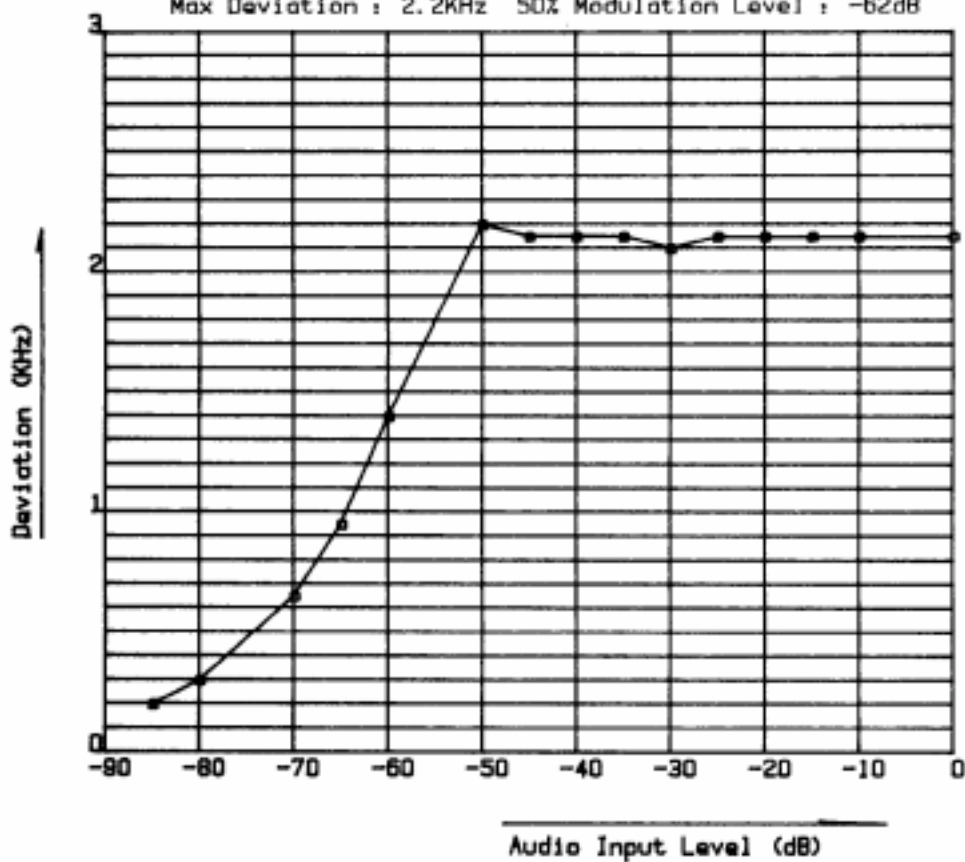

### Modulation Characteristics FCC ID: ACJ96NKX-TR325

Model No. : KX-TR325 1V=0dB at 2KHz Deviation : Minus

Max Deviation : 2.2KHz 50% Modulation Level : -62dB

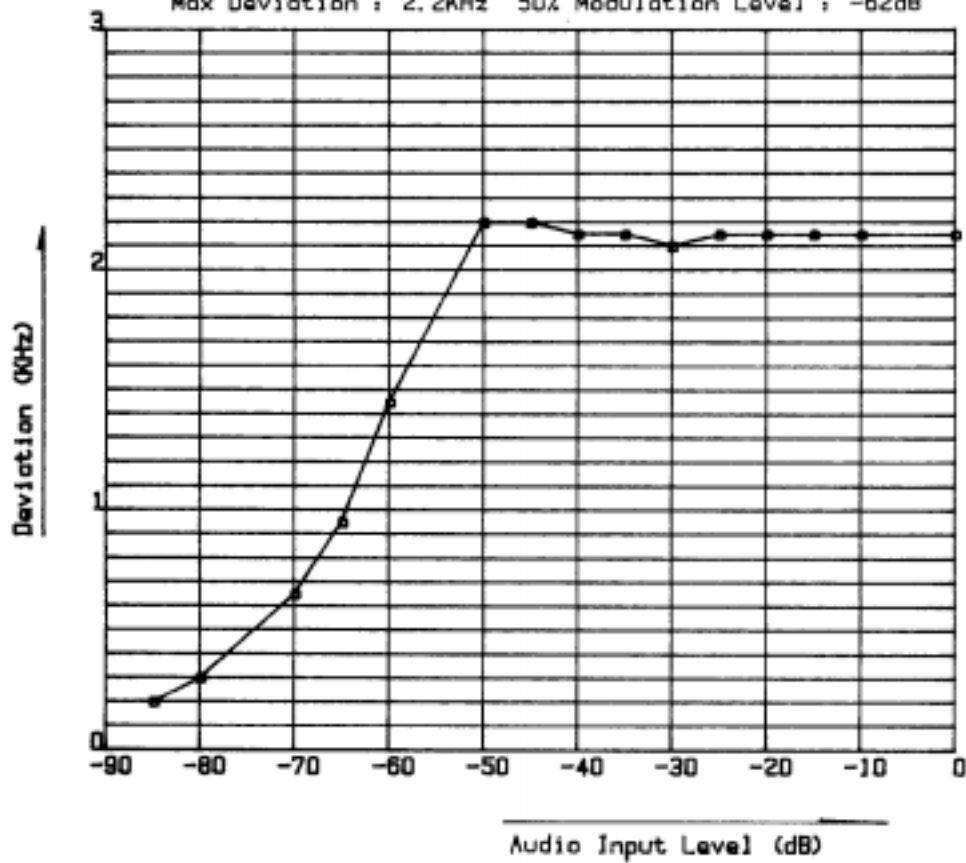

### Modulation Characteristics FCC ID: ACJ96NKX-TR325

Model No. : KX-TR325 1V=0dB at 2.5KHz Deviation : PLUS

Max Deviation : 2.1KHz 50% Modulation Level : -65dB

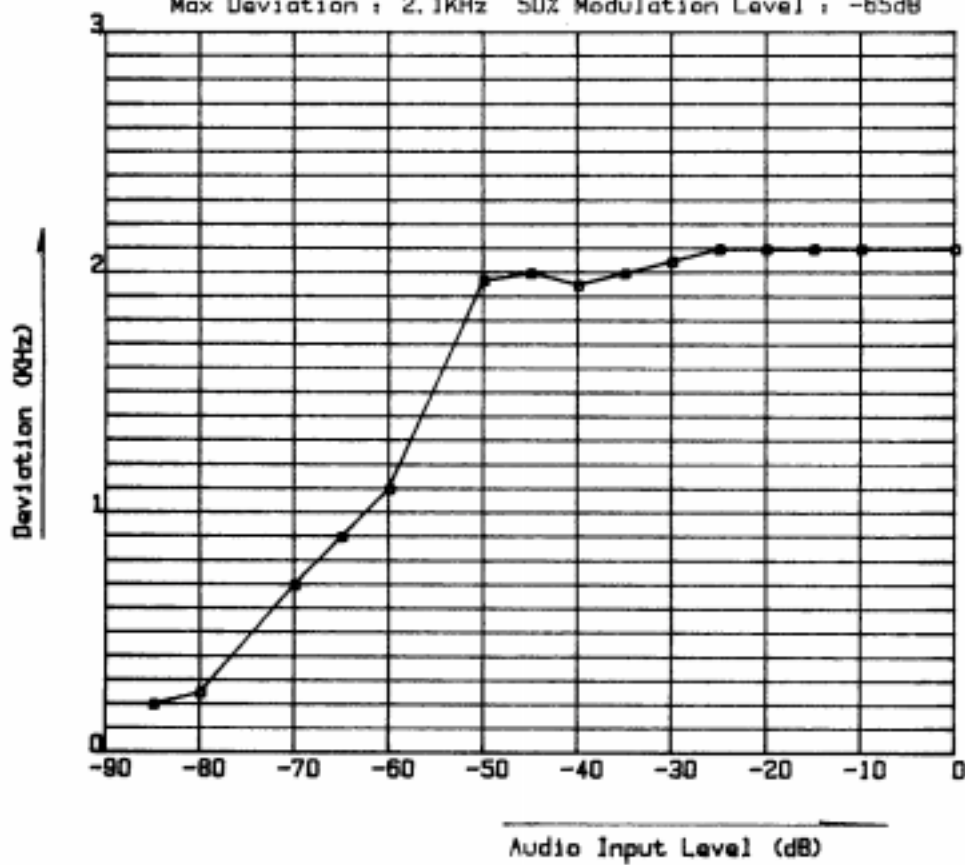

### Modulation Characteristics FCC ID: ACJ96NKX-TR325

Model No. : KX-TR325 1V=0dB at 2.5KHz Deviation : Minus

Max Deviation : 2.15KHz 50% Modulation Level : -65dB

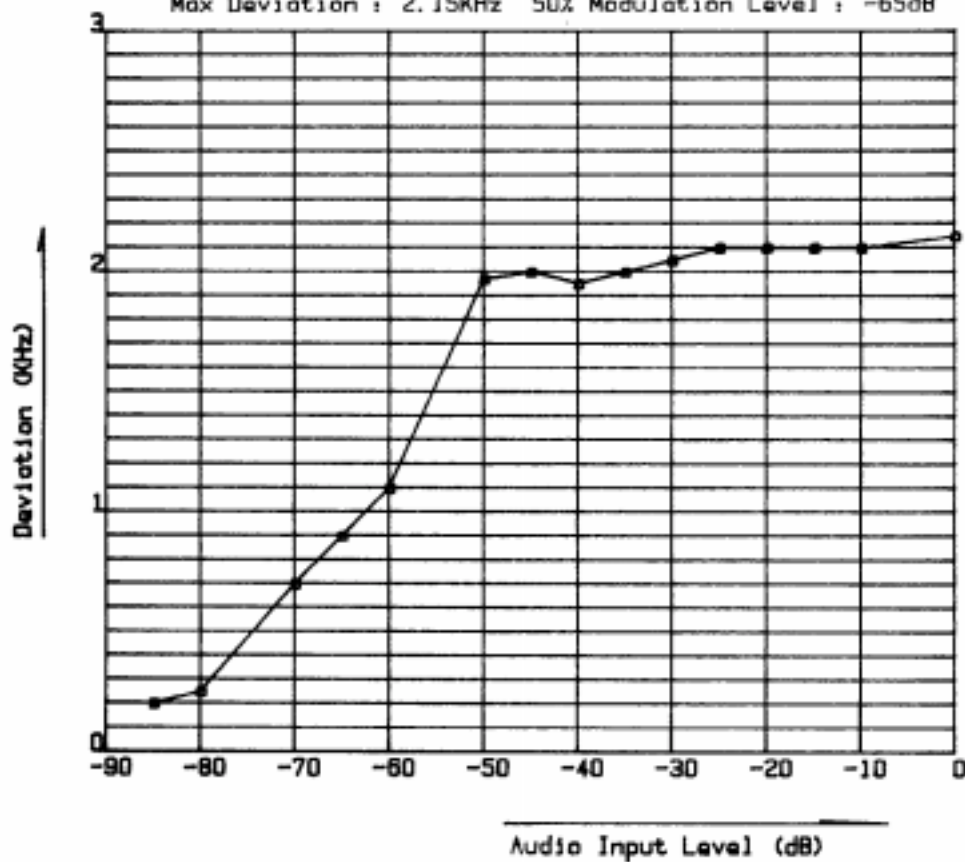

### Modulation Characteristics FCC ID: ACJ96NKX-TR325

Model No. : KX-TR325 1V=0dB at 3KHz Deviation : PLUS

Max Deviation : 1.6KHz 50% Modulation Level : -65dB

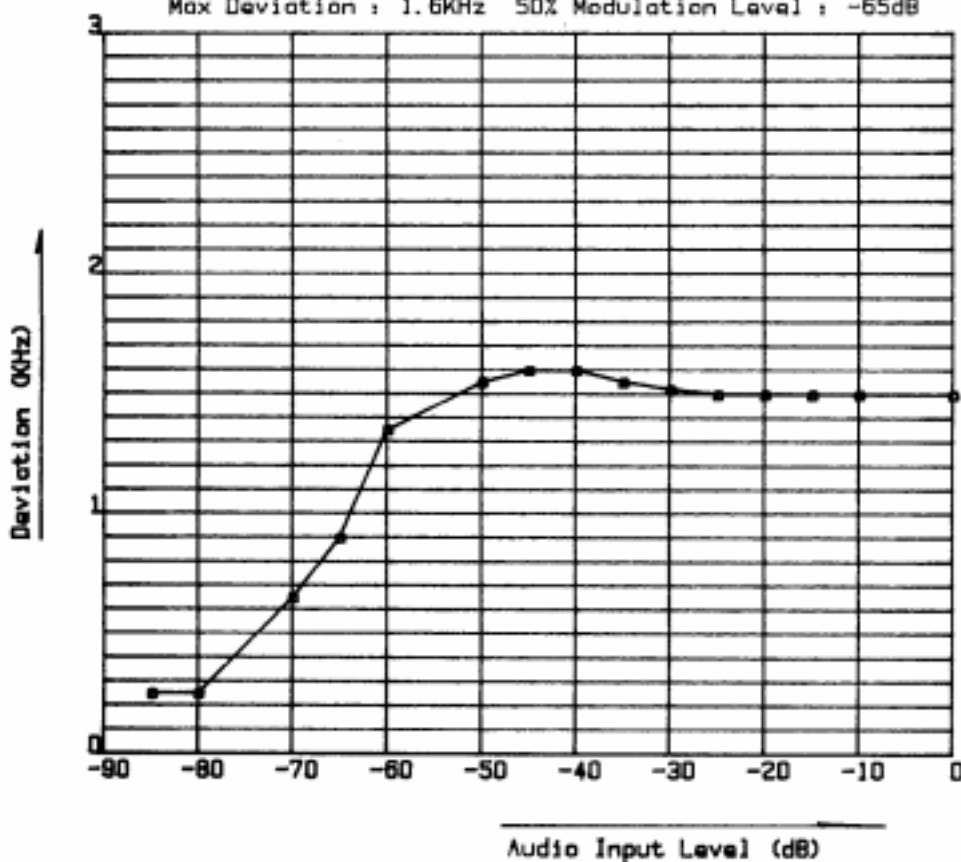

### Modulation Characteristics FCC ID: ACJ96NKX-TR325

Model No. : KX-TR325 1V=0dB at 3KHz Deviation : MINUS

Max Deviation : 1.6KHz 50% Modulation Level : -65dB

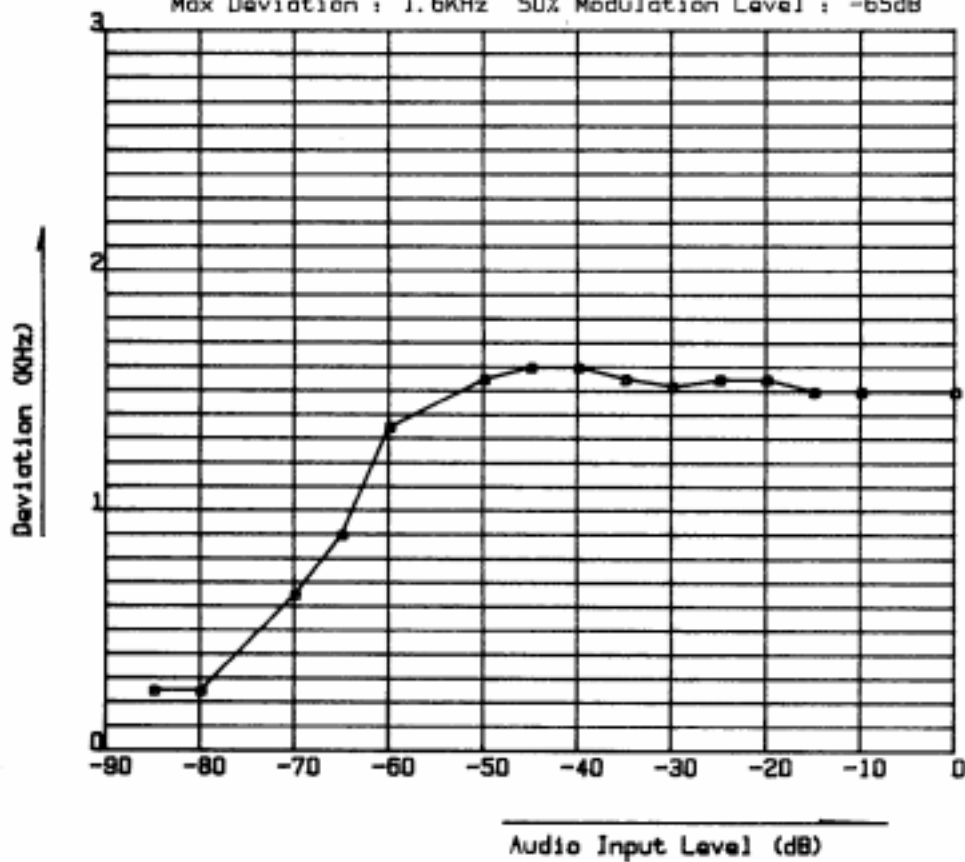

Low Pass Filter Characteristic  
FCC ID: ACJ96NKX-TR325 Model No.: KX-TR325

REF -4.2 DBM  
10 DB/DIV  
RANGE -5.0 DBM  
MARKER 1 001.5 HZ  
-6.6 DBM

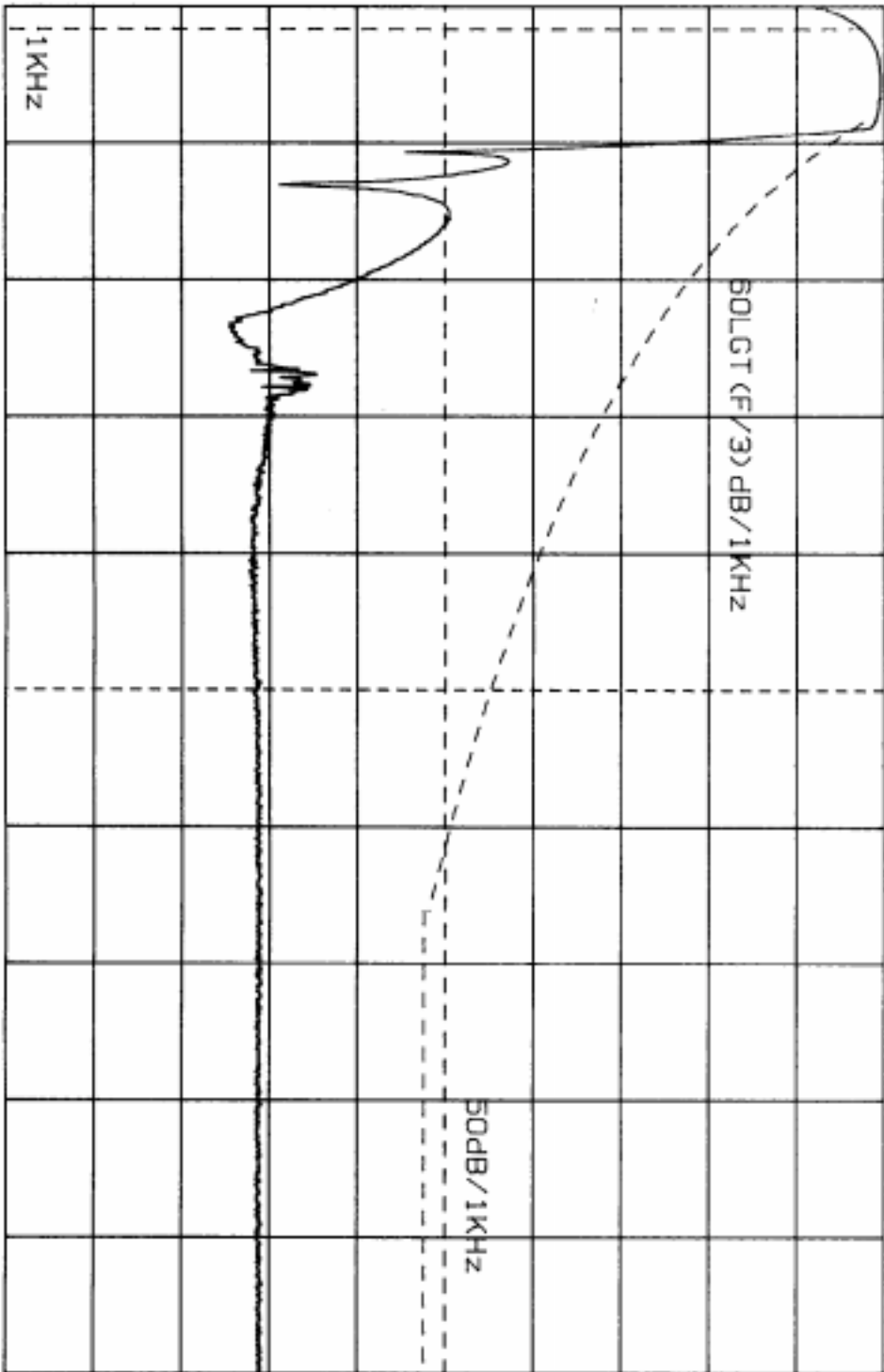

START 500.0 HZ  
RBW 30 HZ  
VBW 100 HZ  
STOP 30 000.0 HZ  
ST 65.6 SEC

## Occupied Bandwidth Measurement

Test Date: October 30, 1999  
Temp.: 24 °C ; Humi.: 50 %

### 1) Occupied Bandwidth measurement

#### Measurement Results:

Attached Graph : Refer to pages 42 - 49.

Audio input level at 50% modulation of the maximum response frequency(xx.x kHz) : xx dBV

The TUT was modulated at a level 16 dB above the input level produced 50% modulation at the maximum response frequency, and the frequency 2500 Hz.

Input terminal : Microphone

Input level : -62.0 dBV + 16.0 dB

Note : Specified limits(\$95.635(a)(b))

### 2) Widespread Emission measurement

#### Measurement Results:

Attached Graph : Refer to pages 50 - 51.

Note : Specified limits(\$95.635(a)(b))

### 3) Band-edge Emission measurement

#### Measurement Results:

Attached Graph : Refer to pages 52 - 55.

Note : Specified limits(\$95.635(a)(b))

Tester Signature : \_\_\_\_\_

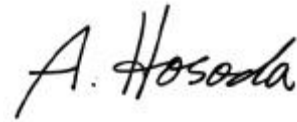

Type Name : Akio Hosoda

### EMISSION LIMITATION

FCC ID:ACJ96NKX-TR325

Model No.:KX-TR325

Mode of EUT : Transmitting

Reference level

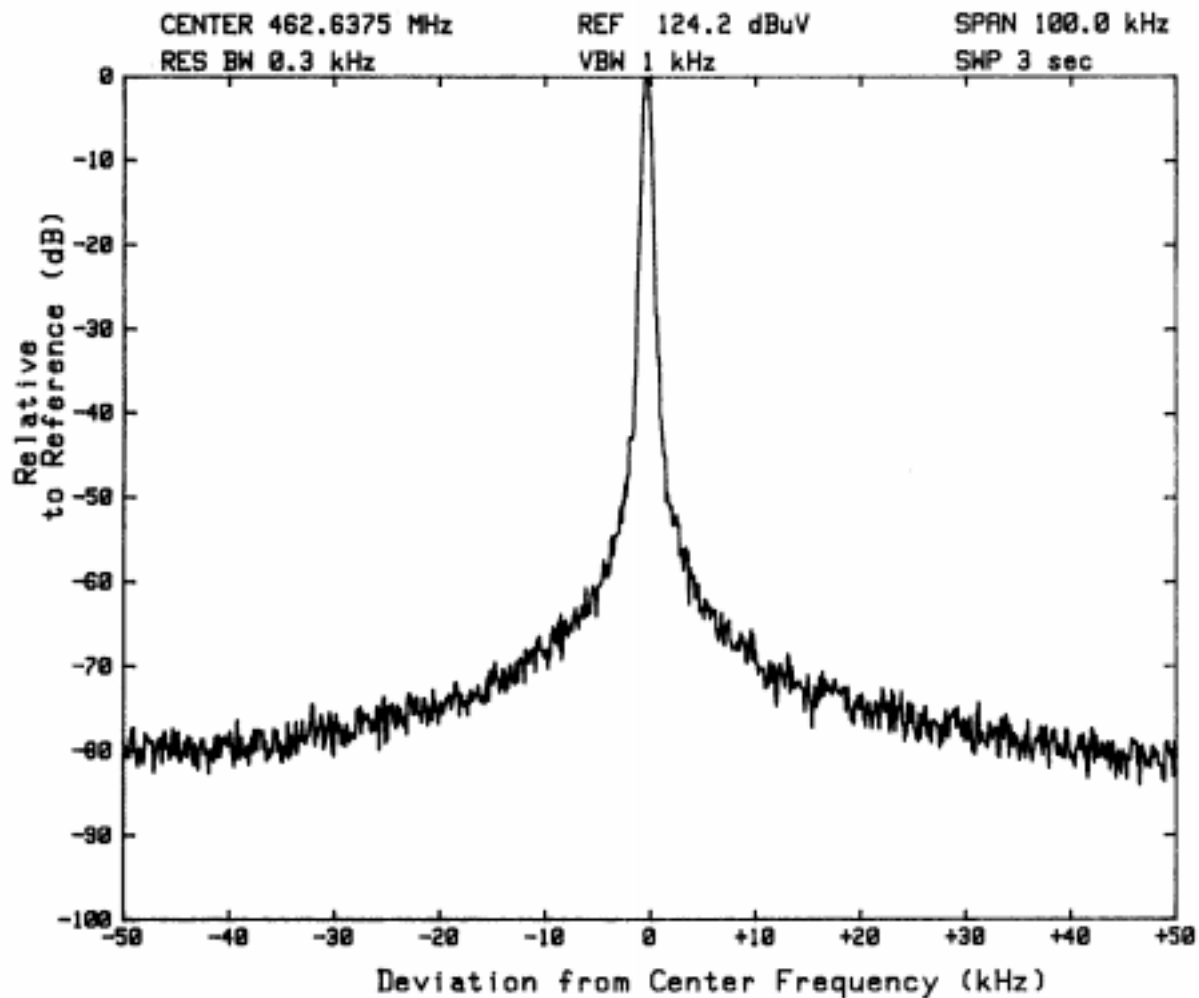

### EMISSION LIMITATION

FCC ID:ACJ96NKX-TR325

Model No.:KX-TR325

Mode of EUT : Transmitting

External Signal : Modulation at 2.5 kHz

CTCSS Cord No.: 0

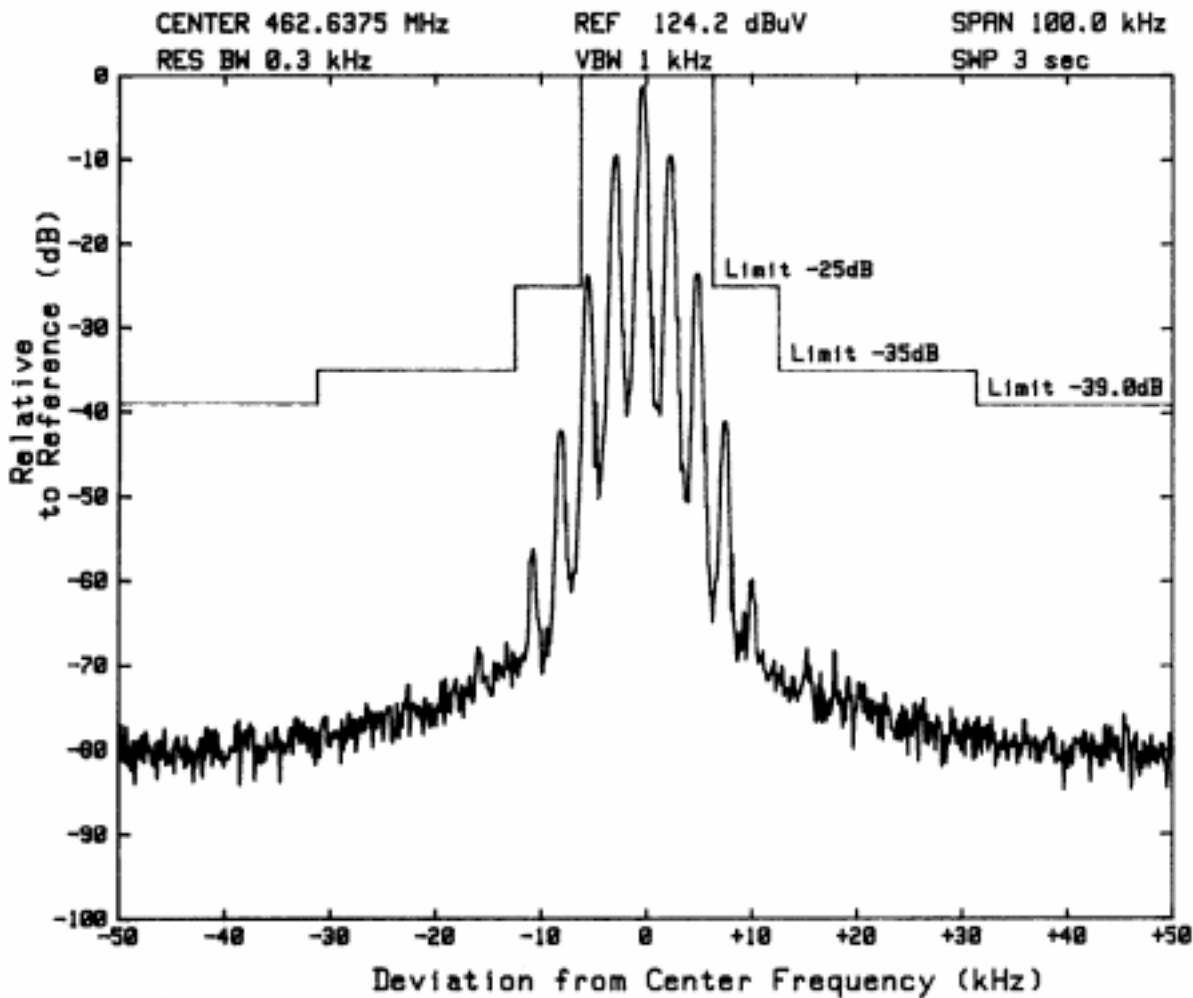

### EMISSION LIMITATION

FCC ID:ACJ96NKX-TR325

Model No.:KX-TR325

Mode of EUT : Transmitting

External Signal : Modulation at 2.5 kHz

CTCSS Cord No.: 1 (67.0Hz)

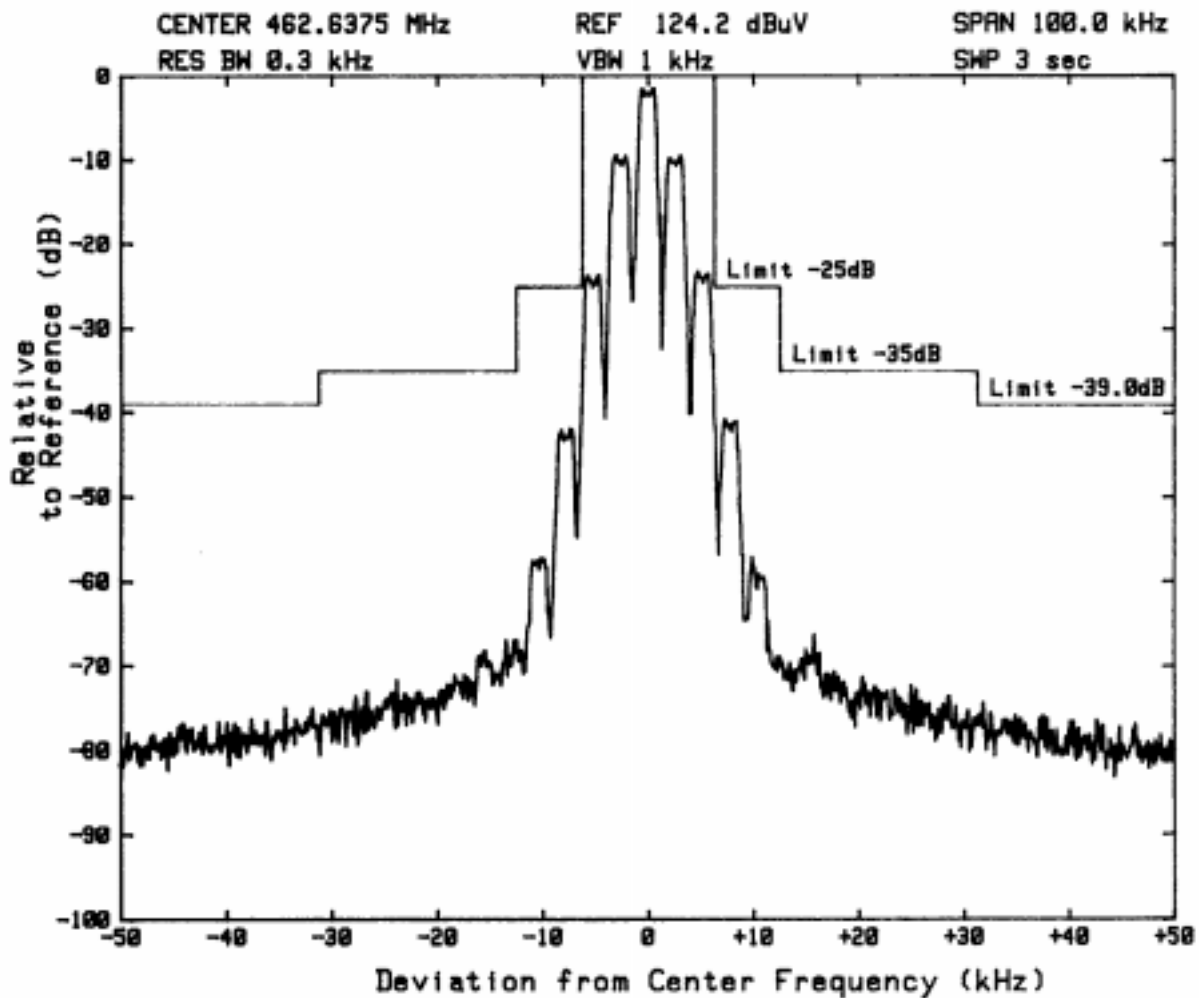

### EMISSION LIMITATION

FCC ID:ACJ96NKX-TR325

Model No.:KX-TR325

Mode of EUT : Transmitting

External Signal : Modulation at 2.5 kHz

CTCSS Cord No.: 38 (250.3Hz)

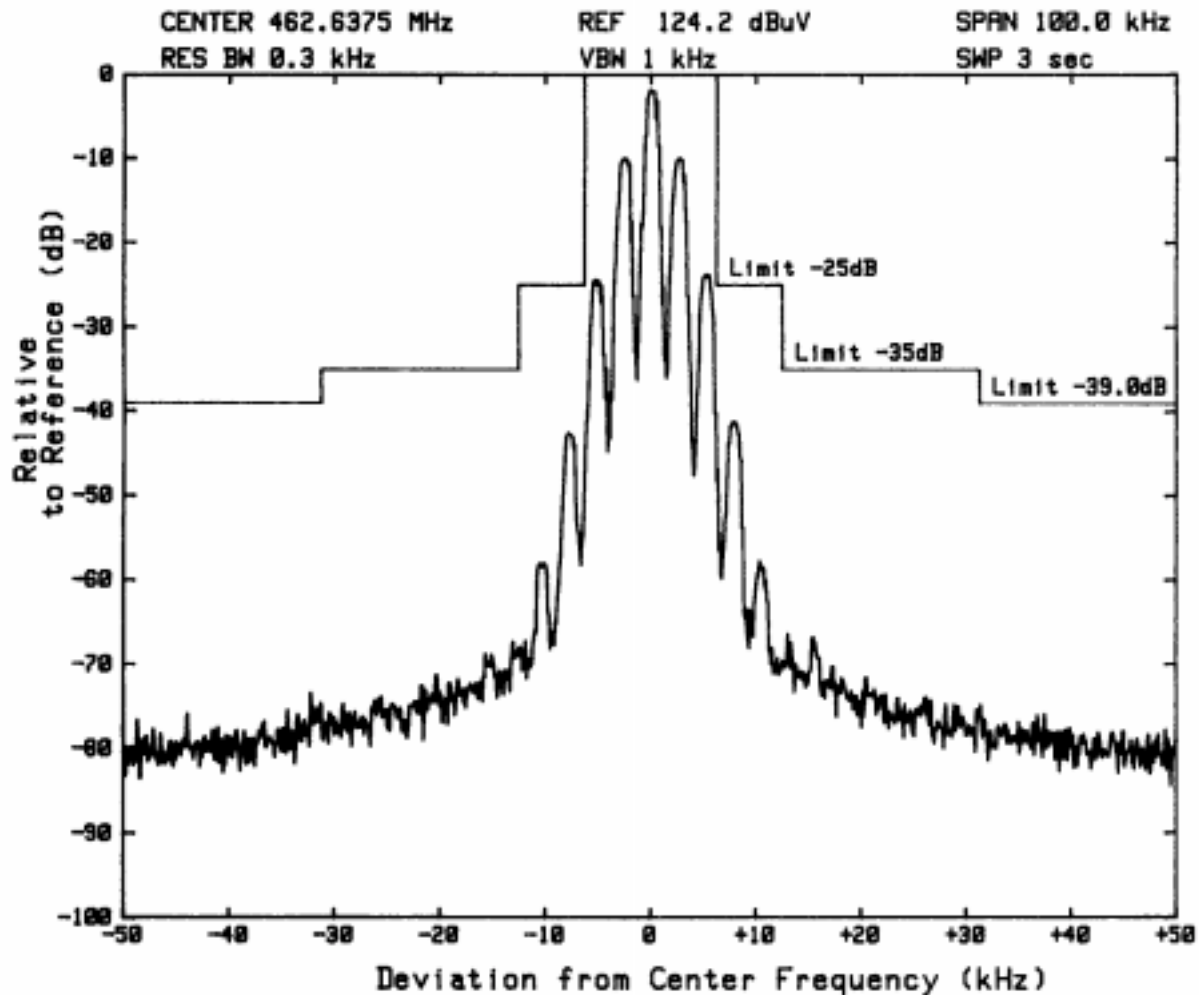

## EMISSION LIMITATION

FCC ID:ACJ96NKX-TR325

Model No.:KX-TR325

Mode of EUT : Transmitting

Reference level

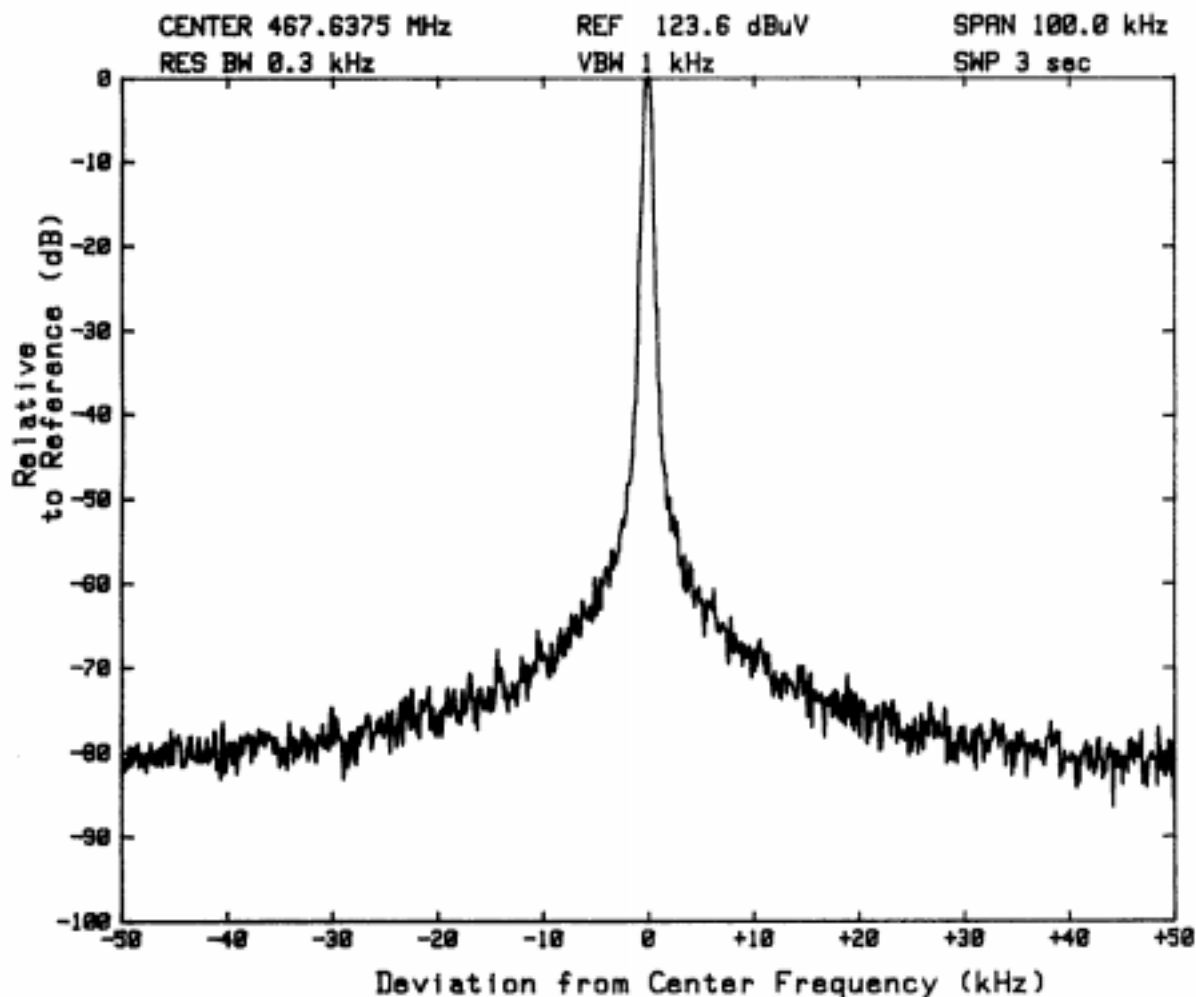

## EMISSION LIMITATION

FCC ID:ACJ96NKX-TR325

Model No.:KX-TR325

Mode of EUT : Transmitting

External Signal : Modulation at 2.5 kHz

CTCSS Cord No.: 0

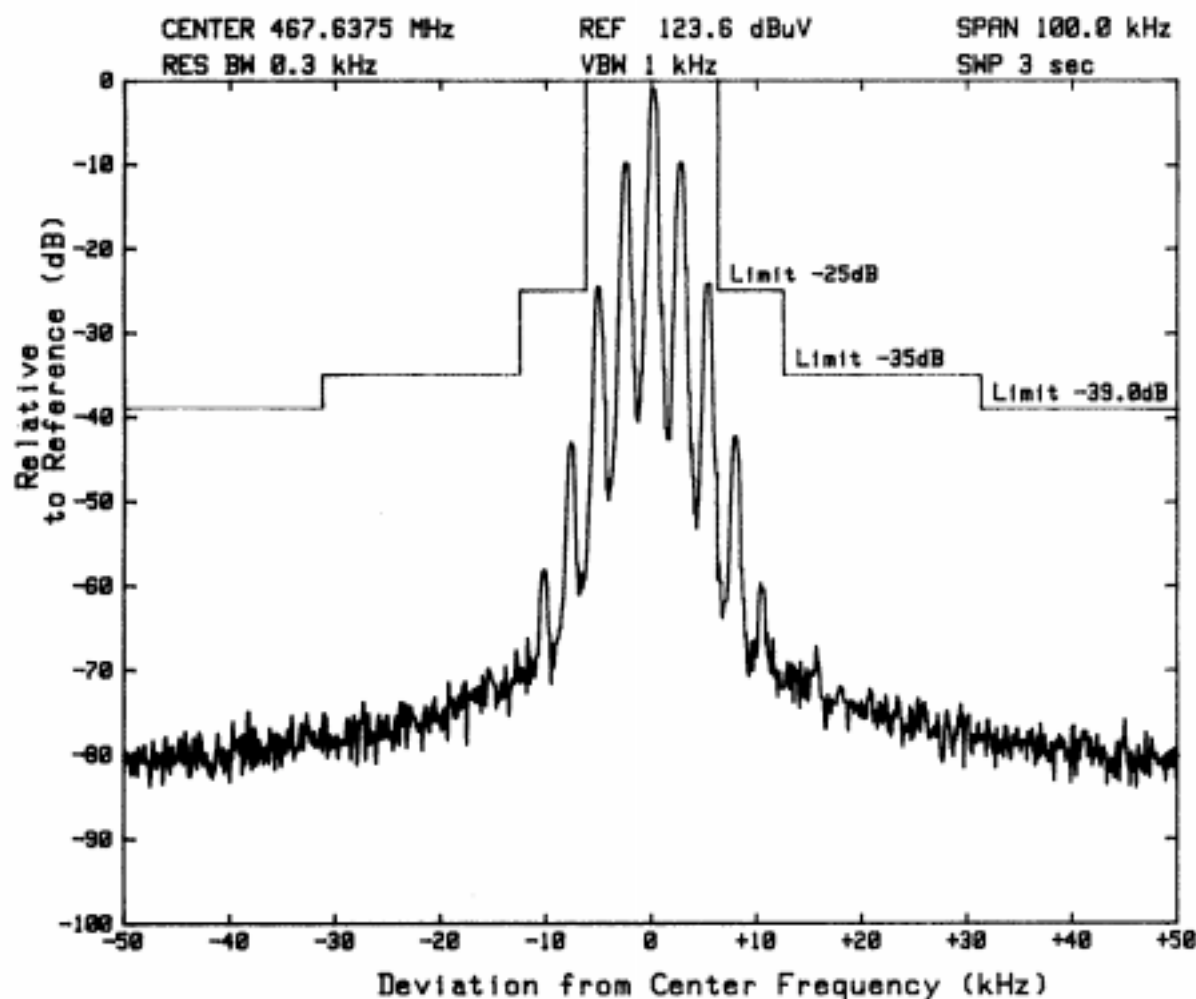

## EMISSION LIMITATION

FCC ID:ACJ96NKX-TR325

Model No.:KX-TR325

Mode of EUT : Transmitting

External Signal : Modulation at 2.5 kHz

CTCSS Cord No.: 1 (67.0Hz)

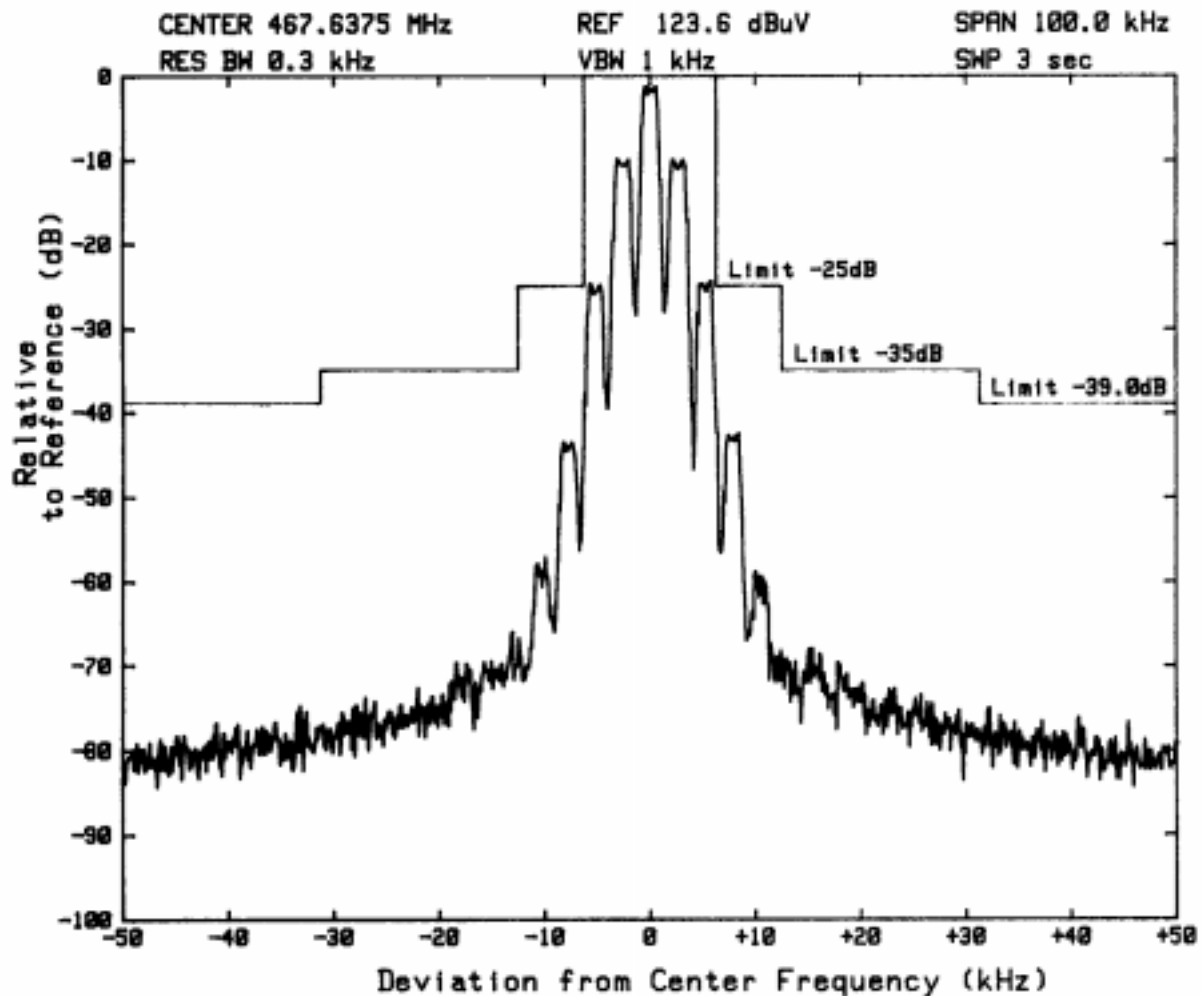

### EMISSION LIMITATION

FCC ID:ACJ96NKX-TR325

Model No.:KX-TR325

Mode of EUT : Transmitting

External Signal : Modulation at 2.5 kHz

CTCSS Cord No.: 38 (250.3Hz)

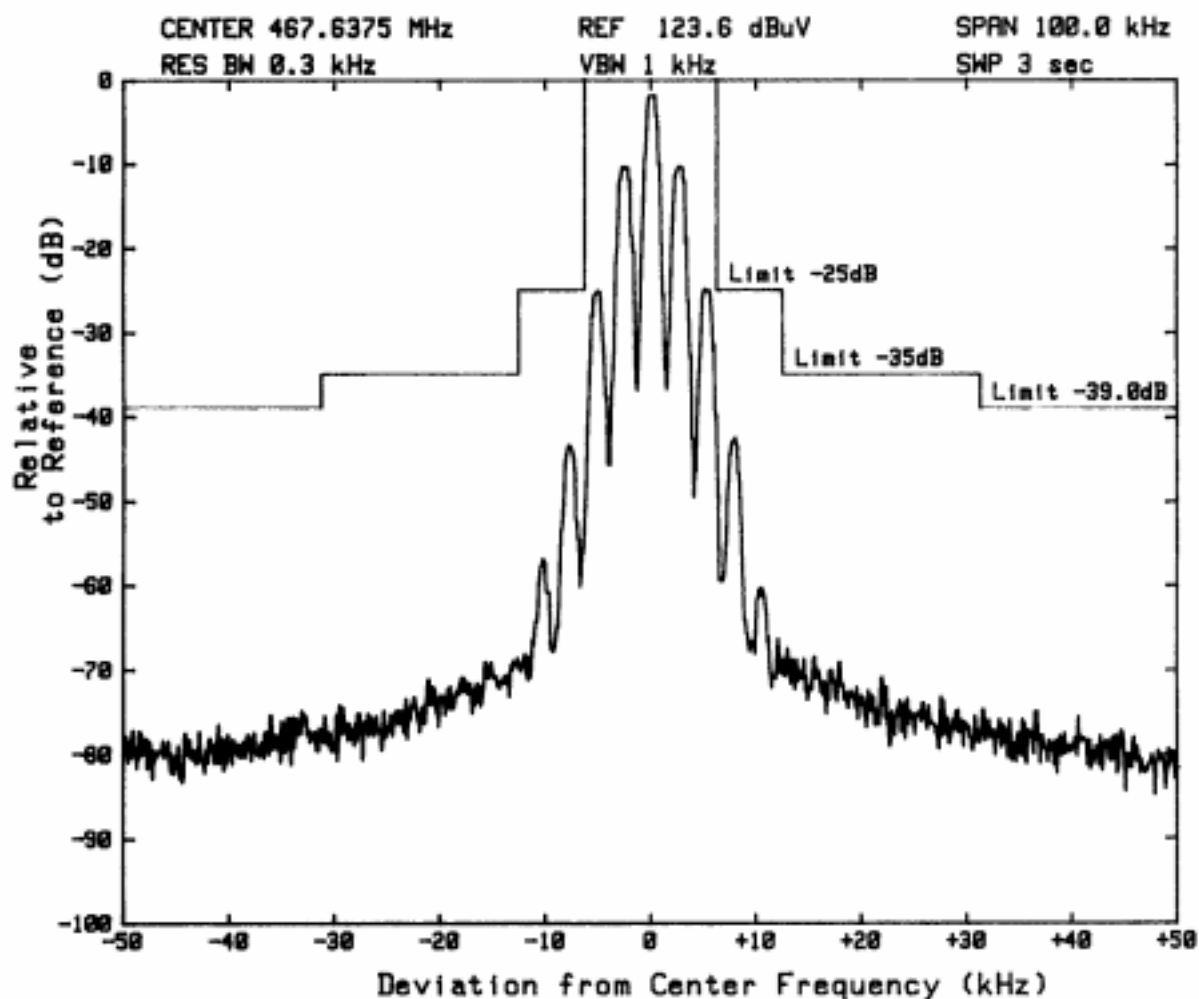

## EMISSION LIMITATION

FCC ID:ACJ96NKX-TR325

Model No.:KX-TR325

Mode of EUT : Transmitting

External Signal : Modulation at 2.5 kHz

CTCSS Cord No.: 1 (67.0Hz)

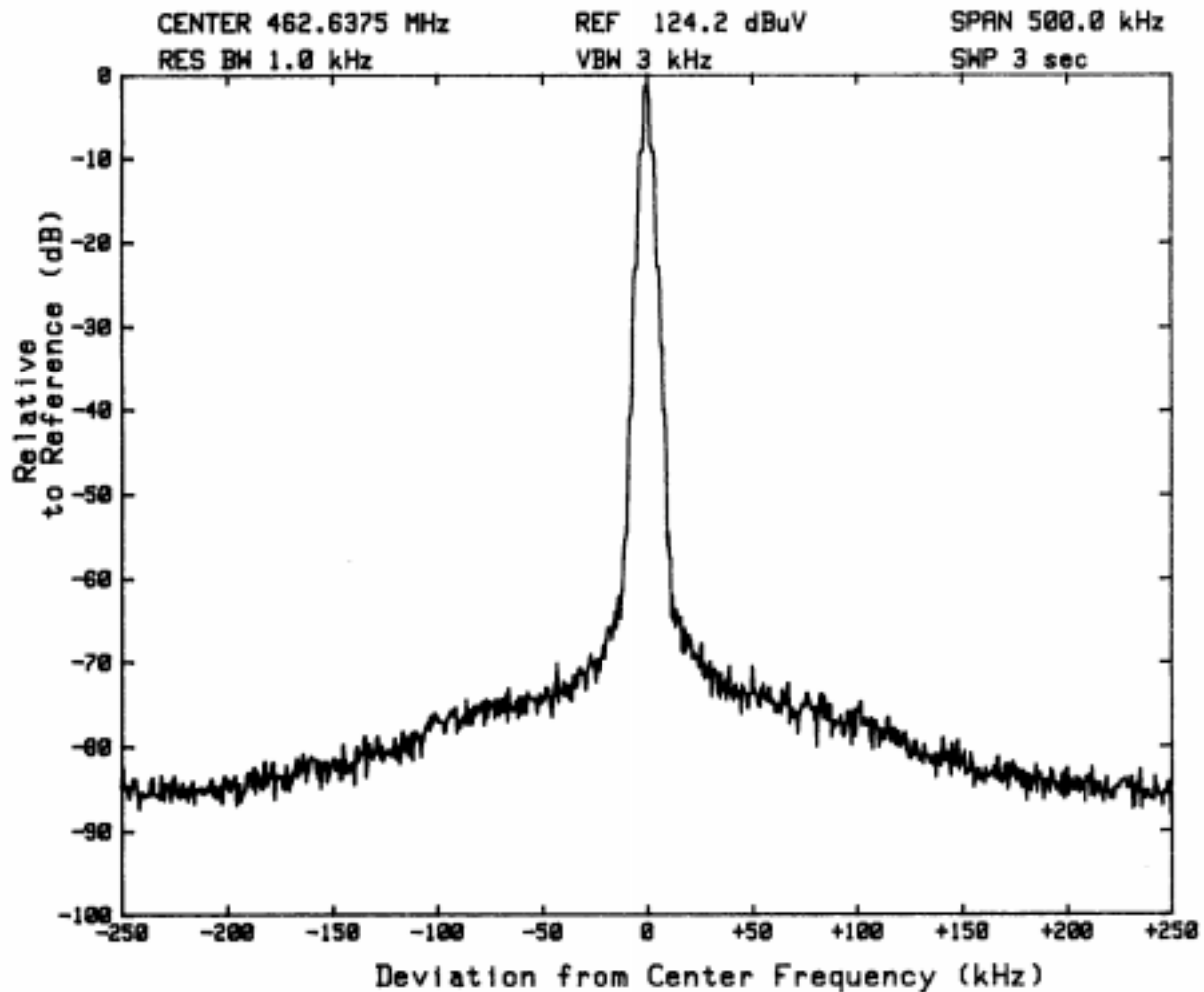

### EMISSION LIMITATION

FCC ID:ACJ96NKX-TR325

Model No.:KX-TR325

Mode of EUT : Transmitting

External Signal : Modulation at 2.5 kHz

CTCSS Cord No.: 1 (67.0Hz)

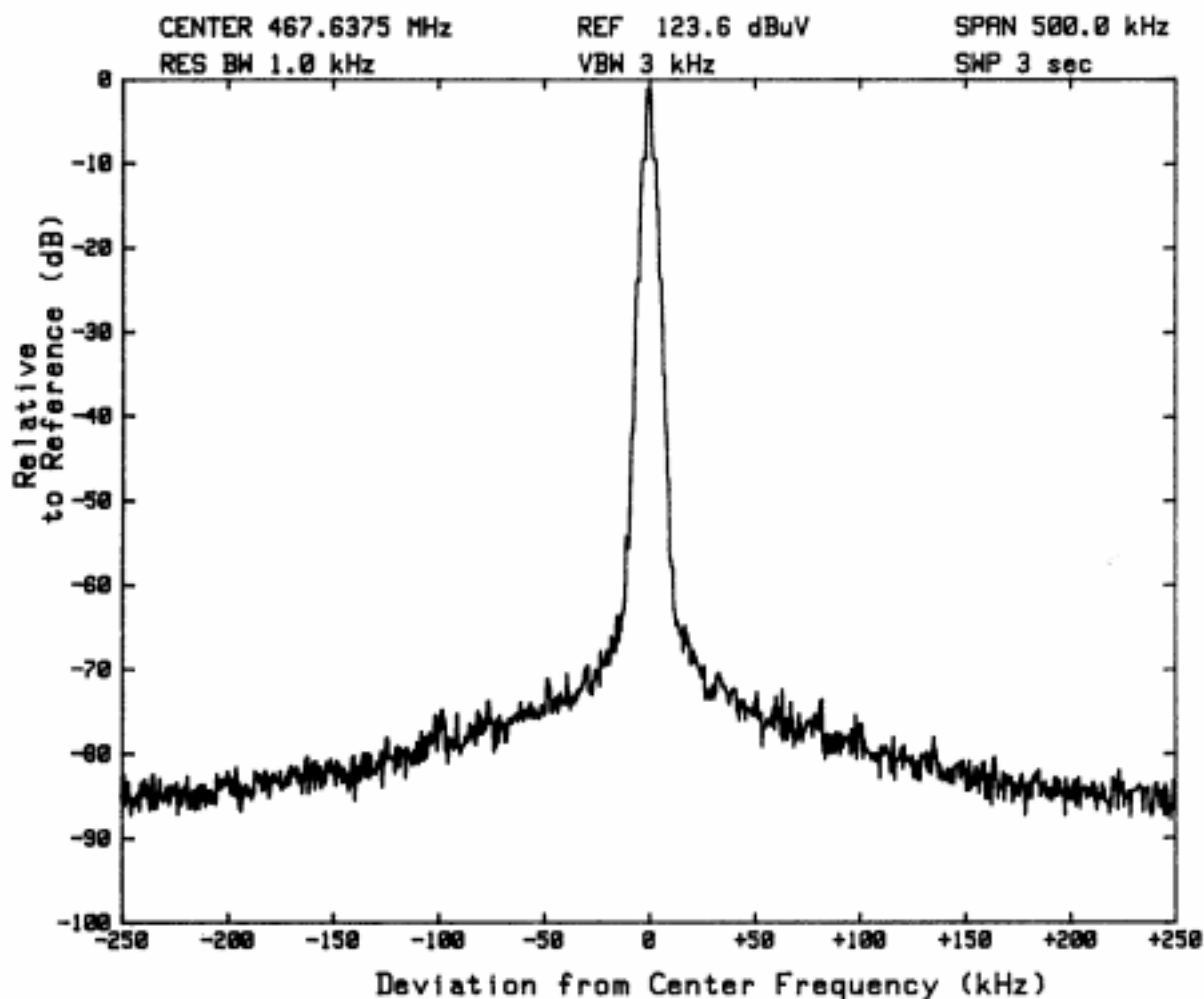

## EMISSION LIMITATION

FCC ID:ACJ96NKX-TR325

Model No.:KX-TR325

Mode of EUT : Transmitting(CH #1)

External Signal : Modulation at 2.5 kHz

CTCSS Cord No.: 1 (67.0Hz)

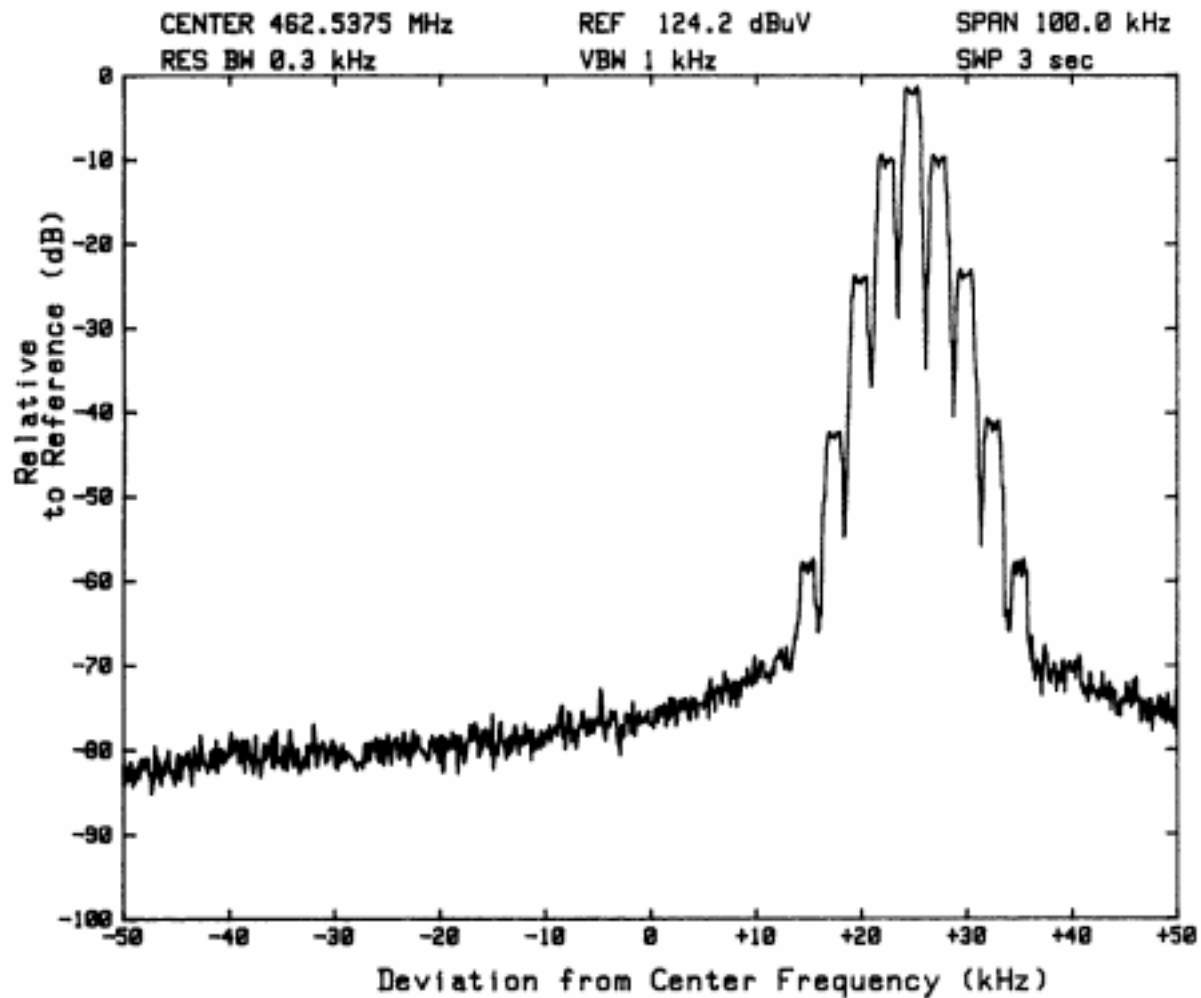

## EMISSION LIMITATION

FCC ID:ACJ96NKX-TR325

Model No.:KX-TR325

Mode of EUT : Transmitting(CH #7)

External Signal : Modulation at 2.5 kHz

CTCSS Cord No.: 1 (67.0Hz)

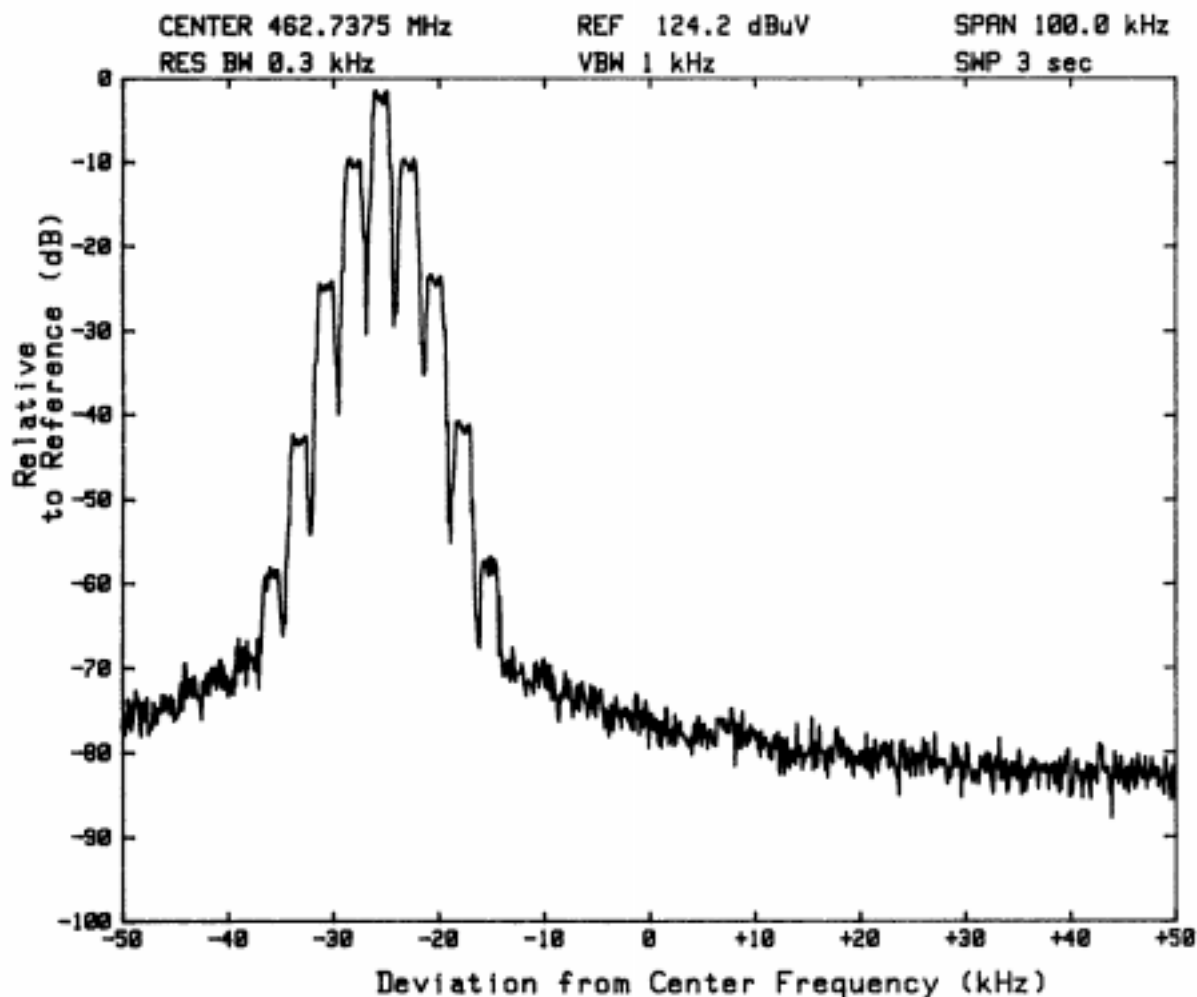

## EMISSION LIMITATION

FCC ID:ACJ96NKX-TR325

Model No.:KX-TR325

Mode of EUT : Transmitting(CH #8)

External Signal : Modulation at 2.5 kHz

CTCSS Cord No.: 1 (67.0Hz)

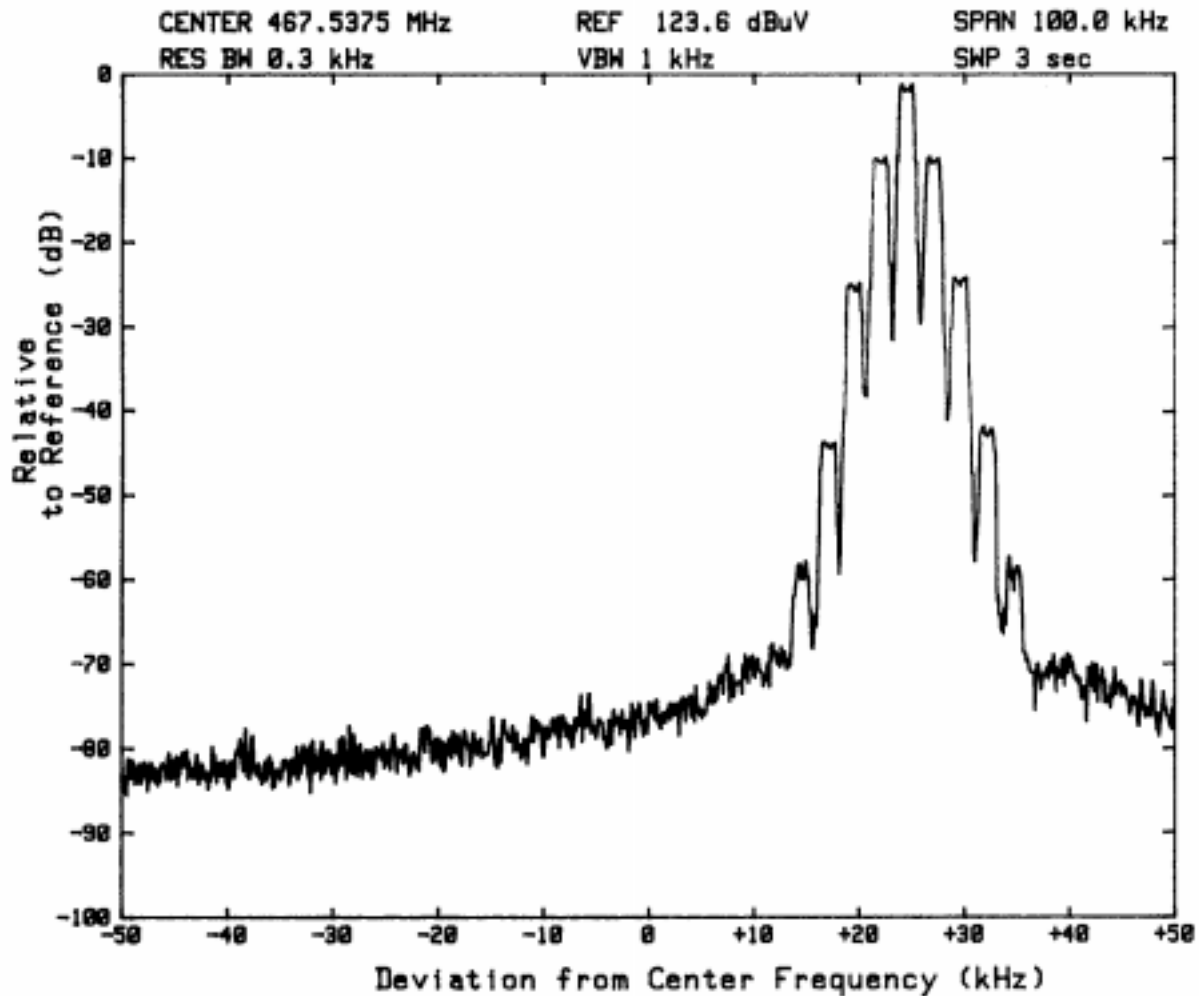

## EMISSION LIMITATION

FCC ID:ACJ96NKX-TR325

Model No.:KX-TR325

Mode of EUT : Transmitting(CH #14)

External Signal : Modulation at 2.5 kHz

CTCSS Cord No.: 1 (67.0Hz)

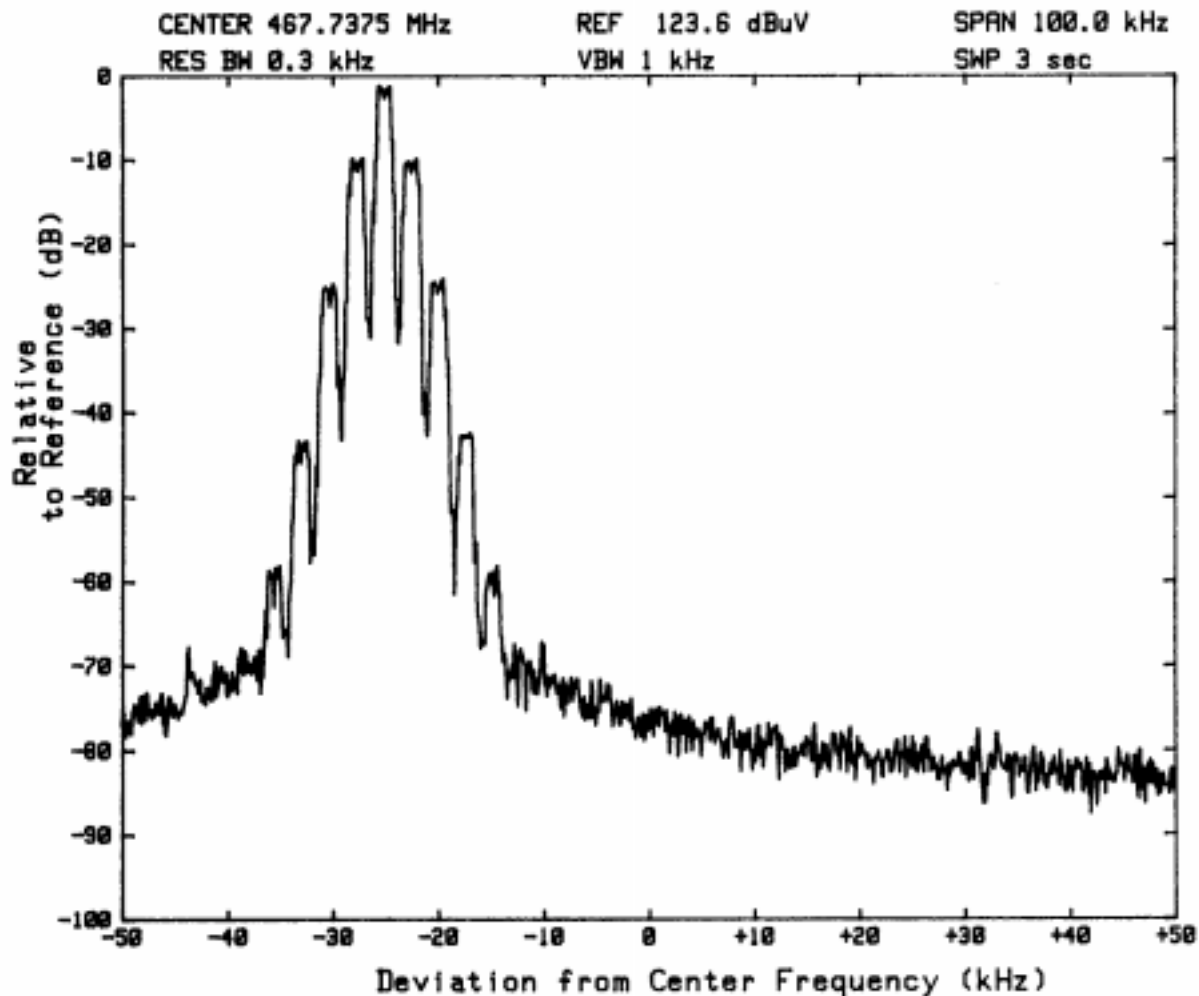

## Unwanted Radiation Measurement

Test Date: October 29, 1999  
 Temp.: 18 °C ; Humi.: 50 %

### Measurement Results:

1) Transmitting Frequency : 462.6375 MHz

Frequency (MHz)	Corr. Factor (dB)	Meter Reading (dBm)		ERP (dBm)		Limits (dBm)	Margin (dB)	Remarks (Note 5)
		Horiz.	Vert.	Horiz.	Vert.			
441.4	1.5	-56.7	-54.7	-55.2	-53.2	-13.0	+40.2	B
462.6375	61.7	-35.9	-35.7	25.8	26.0		Note 1	B
925.3	2.0	-37.0	-35.0	-35.0	-33.0	-13.0	+20.0	B
1387.9	9.5	-30.0	-30.0	-20.5	-20.5	-13.0	+7.5	A
1850.6	11.8	-44.0	-43.0	-32.2	-31.2	-13.0	+18.2	A
2313.2	13.9	-46.0	-43.0	-32.1	-29.1	-13.0	+16.1	A
2775.8	13.3	-40.0	-42.0	-26.7	-28.7	-13.0	+13.7	A
3238.5	14.4	-39.0	-42.0	-24.6	-27.6	-13.0	+11.6	A
3701.1	15.6	-55.0	-51.0	-39.4	-35.4	-13.0	+22.4	A
4163.7	13.2	-60.0	-63.0	-46.8	-49.8	-13.0	+33.8	A
4626.4	14.0	-60.0	-59.0	-46.0	-45.0	-13.0	+32.0	A

- continue -

Sample of calculated result at 1387.9 MHz, as the Minimum Margin point:

$$\begin{array}{rcl} \text{Correction Factor} & = & 9.5 \text{ dB} \\ +) \text{ Meter Reading} & = & -30.0 \text{ dBm} \\ \hline \text{Result} & = & -20.5 \text{ dBm} \end{array}$$

Minimum Margin :  $-13.0 - (-20.5) = 7.5(\text{dB})$

The point shown on "\_\_\_" is the Minimum Margin Point.

Note :1. Refer to page 30.

For fundamental frequency

Corr. Factor : Coupling factor(Dual directional coupler) + Cable loss - Gain of Half-wave dipole antenna

2. a) Up to 1GHz except for fundamental frequency

Corr. Factor : Cable loss - Balun loss of half-wave dipole antenna

b) Over 1GHz

Corr. Factor : Gain of Horn Ant. - Gain of Half-wave dipole antenna

3. The spectrum was checked from 3.6864 MHz up to the tenth harmonic frequency.

4. All emissions not listed were found to be more than 20 dB below the limit.

**Remarks:**

Note 5	Detector Function	RES. B.W	V.B.W	Sweep T	Span
A	Peak (SP)	1 MHz	1 MHz	20 msec	0 Hz
B	Peak (ESV)	120 kHz	--	--	---

Tester Signature : \_\_\_\_\_

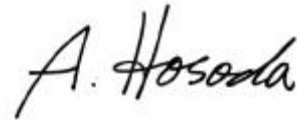

Type Name : Akio Hosoda

## Unwanted Radiation Measurement

Test Date: October 29, 1999  
 Temp.: 18 °C ; Humi.: 50 %

Measurement Results:

2) Transmitting Frequency : 467.6375 MHz

Frequency (MHz)	Corr. Factor (dB)	Meter Reading (dBm)		ERP (dBm)		Limits (dBm)	Margin (dB)	Remarks (Note 5)
		Horiz.	Vert.	Horiz.	Vert.			
467.6375	61.7	-36.8	-36.8	24.9	24.9		Note 1	B
935.3	2.0	-33.7	-34.6	-31.7	-32.6	-13.0	+18.7	B
1402.9	9.5	-35.0	-29.0	-25.5	-19.5	-13.0	+6.5	A
1870.6	11.8	-42.5	-41.0	-30.7	-29.2	-13.0	+16.2	A
2338.2	13.9	-49.0	-47.0	-35.1	-33.1	-13.0	+20.1	A
2805.8	13.3	-38.0	-39.0	-24.7	-25.7	-13.0	+11.7	A
3273.5	14.4	-41.0	-42.0	-26.6	-27.6	-13.0	+13.6	A
3741.1	15.6	-57.0	-52.0	-41.4	-36.4	-13.0	+23.4	A
4208.7	13.2	-64.0	-57.0	-50.8	-43.8	-13.0	+30.8	A
4676.4	14.0	-58.0	-59.0	-44.0	-45.0	-13.0	+31.0	A

- continue -

Sample of calculated result at 1402.9 MHz, as the Minimum Margin point:

$$\begin{array}{rcl} \text{Correction Factor} & = & 9.5 \text{ dB} \\ +) \text{ Meter Reading} & = & -29.0 \text{ dBm} \\ \hline \text{Result} & = & -19.5 \text{ dBm} \end{array}$$

Minimum Margin :  $-13.0 - (-19.5) = 6.5(\text{dB})$

The point shown on "\_\_\_" is the Minimum Margin Point.

Note :1. Refer to page 30.

For fundamental frequency

Corr. Factor : Coupling factor(Dual directional coupler) + Cable loss - Gain of Half-wave dipole antenna

2. a) Up to 1GHz except for fundamental frequency

Corr. Factor : Cable loss - Balun loss of half-wave dipole antenna

b) Over 1GHz

Corr. Factor : Gain of Horn Ant. - Gain of Half-wave dipole antenna

3. The spectrum was checked from 3.6864 MHz up to the tenth harmonic frequency.

4. All emissions not listed were found to be more than 20 dB below the limit.

**Remarks:**

Note 5	Detector Function	RES. B.W	V.B.W	Sweep T	Span
A	Peak (SP)	1 MHz	1 MHz	20 msec	0 Hz
B	Peak (ESV)	120 kHz	--	--	---

Tester Signature : \_\_\_\_\_



Type Name : Akio Hosoda

## Frequency Stability Measurement

### Measurement Results:

#### a) Frequency Stability Measurement versus Temperature

a-1) Transmitting Frequency : 462.6375 MHz  
Supply voltage for the TUT : DC 4.5 V

Test Date: October 27, 1999

Ambient Temperature (°C)	Deviation (ppm)		Limits (ppm)	Margin (ppm)
	Startup	2 minutes		
-20	-0.46	+1.22	± 2.50	1.28
-10	+0.62	+1.54	± 2.50	0.96
0	+1.56	+1.43	± 2.50	0.94
+10	+1.37	+0.55	± 2.50	1.13
+20	-0.44	-0.67	± 2.50	1.83
+30	-0.68	-0.87	± 2.50	1.63
+40	-0.76	-0.23	± 2.50	1.74
+50	-0.05	+1.36	± 2.50	1.14

a-2) Transmitting Frequency : 467.6375 MHz  
Supply voltage for the TUT : DC 4.5 V

Test Date: October 28, 1999

Ambient Temperature (°C)	Deviation (ppm)		Limits (ppm)	Margin (ppm)
	Startup	2 minutes		
-20	-1.09	+0.27	± 2.50	1.41
-10	+1.22	+1.44	± 2.50	1.06
0	+1.50	+1.20	± 2.50	1.00
+10	+1.19	+0.45	± 2.50	1.31
+20	+0.18	-0.52	± 2.50	1.98
+30	-0.82	-0.86	± 2.50	1.64
+40	-0.88	-0.57	± 2.50	1.62
+50	+0.09	+1.35	± 2.50	1.15

Note : 1. Time elapse versus temperature : Refer to page 62.

2. The measurement were made after all of components of the oscillator sufficiently stabilized at each temperature.

Tester Signature : \_\_\_\_\_

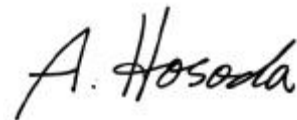

Type Name : Akio Hosoda

## Frequency Stability Measurement

### Measurement Results:

#### b) Frequency Stability Measurement versus Power Supply Voltage

b-1) Transmitting Frequency : 462.6375 MHz  
 Supply voltage for the TUT : DC 3.3 V

Test Date: October 28, 1999

Ambient Temperature (°C)	Deviation (ppm)		Limits (ppm)	Margin (ppm)
	Startup	2 minutes		
+20	+0.01	-0.28	± 2.50	2.22

b-2) Transmitting Frequency : 467.6375 MHz  
 Supply voltage for the TUT : DC 3.3 V

Test Date: October 28, 1999

Ambient Temperature (°C)	Deviation (ppm)		Limits (ppm)	Margin (ppm)
	Startup	2 minutes		
+20	+0.25	-0.24	± 2.50	2.25

Note : The measurement were made after all of components of the oscillator sufficiently stabilized at each temperature.

Sample Calculation at 462.6375 MHz (0°C Startup DC 4.5V) at the minimum Margin point:  

$$((462.6382219 - 462.6375)/462.6375) \times 10^6 = +1.56 \text{ (ppm)}$$
 Minimum Margin : 2.50 - 1.56 = 0.94(ppm)  
 The point shown on "\_\_\_" is the Minimum Margin Point.

Tester Signature : 

Type Name : Akio Hosoda

Time elapse versus temperature

10 mm / hour

