

# Panasonic System Networks Evaluation Technology Co., Ltd. EMC Center



## *EMC TEST REPORT*

---

REPORT NUMBER : ERJ13-19038R00FR

APPLICANT : Panasonic Corporation

PRODUCT : SIP Cordless Handset

MODEL NUMBER : KX-TPA73

STANDARD : FCC Rules and Regulations Part 15  
Subpart B - Unintentional Radiators  
ICES-003 Issue 6

Issue Date: December 9, 2019

Authorized by: *K. Nakamura*  
K. Nakamura  
(Quality Manager)

Reviewed by: *H. Nakayama*  
H. Nakayama  
(Technical Manager)

The test results only relate to the items tested.

This test report shall not be reproduced except in full without the written approval of  
Panasonic System Networks Evaluation Technology Co., Ltd. EMC Center.

This document may be altered or revised by Panasonic System Networks Evaluation Technology  
EMC Center only, and shall be noted in the revision section in this document.

**TABLE of CONTENTS**

---

|   | Page  |
|---|-------|
| SECTION 1. GENERAL INFORMATION  | 3     |
| SECTION 2. SUMMARY OF RESULTS   | 4     |
| SECTION 3. TEST RESULTS   |       |
| 3.1 Radiated Emission 30 MHz - 1000 MHz                                     | 5     |
| 3.2 Radiated Emission 1 GHz - 6 GHz   | 6     |
| 3.3 Conducted Emission  | 7     |
| SECTION 4. DESCRIPTION OF EUT   |       |
| 4.1 Configuration of EUT  | 8     |
| 4.2 EUT and Support Equipment Used  | 8     |
| 4.3 Cable(s) Used   | 9     |
| 4.4 Operating Condition(s)  | 9     |
| 4.5 Any Deviations from, Additions to or Exclusions from<br>the Test Method | 9     |
| 4.6 Modifications to EUT  | 9     |
| SECTION 6. TEST INSTRUMENTS LIST  |       |
| 6.1 Radiated Emission 30 MHz - 1000 MHz                                     | 10    |
| 6.2 Radiated Emission 1 GHz - 6 GHz   | 11    |
| 6.3 Conducted Emission  | 12    |
| SECTION 7. TEST PROCEDURE(S)  |       |
| 7.1 Radiated Emission   | 13-14 |
| 7.2 Conducted Emission  | 15    |

## SECTION 1. GENERAL INFORMATION

### 1.1 Testing Laboratory

Name: Panasonic System Networks Evaluation Technology Co., Ltd.  
EMC Center  
Address: 1-62, 4-chome, Minoshima Hakata-ku,  
Fukuoka 812-8531, Japan  
TEL: 092-477-3267 (+81-92-477-3267)  
FAX: 092-477-1587 (+81-92-477-1587)  
Test Site: Panasonic System Networks Evaluation Technology Co., Ltd.  
Fukuoka Site  
Address: 1-62, 4-chome, Minoshima Hakata-ku, Fukuoka 812-8531, Japan

### 1.2 Detail of Applicant

Name: Panasonic Corporation  
Address: 1-62, 4-chome, Minoshima Hakata-ku, Fukuoka 812-8531, Japan  
TEL: 050-3380-2671(+81-50-3380-2671)

### 1.3 Information about Test Item

Kind of Test Item: SIP Cordless Handset  
Model Number: KX-TPA73  
  
Trade Mark: Panasonic  
Type of Test Item: Table-top Type  
Condition of Test Item: Pre-Production  
Serial Number: S11CA000052  
Rated Voltage/Frequency: AC 100 V - AC 240 V 50 Hz / 60 Hz  
Highest frequency (\*Note 1): 600 MHz  
Test Item Received Date: August 30, 2019  
Test Date: September 1- 2, 2019

\*Note 1: Highest frequency generated or used in the devices on which the device operates or tunes.

### 1.4 Regulation

Emission: 47 CFR Part 15 - Digital Devices  
Subpart A - General  
Subpart B - Unintentional Radiators (Class B)  
ICES-003 Issue 6  
Section 6 Class B

### 1.5 Test Procedure

General: PSNET-EMC Procedure (EDC02), ANSI C63.4-2014 Section 6  
ITE Measurement: PSNET Procedure (EDX34), ANSI C63.4-2014 Section 11  
Radiated Emission: PSNET Procedure (EDX01,EDY01/02), ANSI C63.4-2014 Section 8  
PSNET Procedure (EDX39), ICES-003 Issue 6 Section 5 (a)(ii),  
Section 5 (b)(ii)  
Conducted Emission: PSNET Procedure (EDX02, EDY03), ANSI C63.4-2014 Section 7  
PSNET Procedure (EDX39), ICES-003 Issue 6 Section 3 (b)

### 1.6 Notes

The results in this report apply only to the sample(s) tested.

The instruments used for the measurements were traceable to the national standards and foreign national standards laboratories.

## SECTION 2. SUMMARY OF RESULTS

### 2.1 General Remarks

The EUT under the test configuration (as shown section 4) was tested according to the requirements of the Regulation as shown section 1.4.

The worst margin of test results was as follows:

| Test Item                              | Worst Margin | Frequency    | Polarity   | Detector   | Reference |
|--|--------------|--------------|------------|------------|-----------|
| Radiated Emission<br>30 MHz - 1000 MHz | 9.5 dB       | 801.115 MHz  | Vertical   | Quasi-peak | Page 5    |
| Radiated Emission<br>1 GHz - 6 GHz     | 17.3 dB      | 2597.660 MHz | Horizontal | Average    | Page 6    |
|  | 25.3 dB      | 2597.660 MHz | Horizontal | Peak       | Page 6    |
| Conducted Emission                     | 20.9 dB      | 0.17775 MHz  | ---        | Quasi-peak | Page 7    |
|  | 22.1 dB      | 1.54200 MHz  | ---        | Average    | Page 7    |

\*Used Test Site up to 1 GHz:

- Fukuoka No.1 Site (D=1.5 m Turn Table), □ ADOX No.2 Site (D=3.0 m Turn Table)
- Measurement Distance 3.0 m, □ ADOX Site, Class A, Measurement Distance 10 m

\*Used Test Site above 1 GHz:

- Fukuoka No.1 Site (D=1.5 m Turn Table), □ ADOX No.2 Site (D=3.0 m Turn Table)
- Measurement Distance 3.0 m

### 2.2 Final Judgment

The EUT fulfills the test requirements of the regulation as shown section 1.4.

### 2.3 Uncertainty

The measurements uncertainty, at time of test, and at least 95 % confidence, was estimated to be as follows:

- Radiated Emission Measurements: +/- 3.84 dB (3 m) [30 MHz - 300 MHz],
- +/- 4.66 dB (3 m) [300 MHz - 1000 MHz]
- +/- 4.72 dB (3 m) [1 GHz - 6 GHz]
- Conducted Emission Measurements: +/-2.38 dB [0.15 MHz - 30 MHz]

### SECTION 3. TEST RESULTS

#### 3.1 Radiated Emission 30 MHz - 1000 MHz

|            |                        |                               |                            |
|------------|------------------------|-------------------------------|----------------------------|
| Model Name | : SIP Cordless Handset | Test condition of instruments |                            |
| Model No.  | : KX-TPA73             | Date                          | : 2019/09/01               |
| Serial No. | : S11CA000052          | Temperature                   | : 24 degree C              |
| Operator   | : E. Abe               | Humidity                      | : 43 % 1016 hPa            |
| Points     | : 12                   | EUT Warm-up Time              | : 30 minutes               |
| Detector   | : QP                   | Distance                      | : 3 m                      |
| RBW        | : 120 kHz              | Test Mode                     | : SP Phone Talk & BT Burst |
|            |                        | Comment                       | : AC 120 V / 60 Hz         |

The measurement was conducted in the condition where maximum emission was detected by the preliminary test.

Level=Emission Level=Meter Reading+ Factor (Antenna + Cable + Preamp)

LIMIT: FCC Part 15 Class B (3 m)

: ICES-003 Class B (3 m)

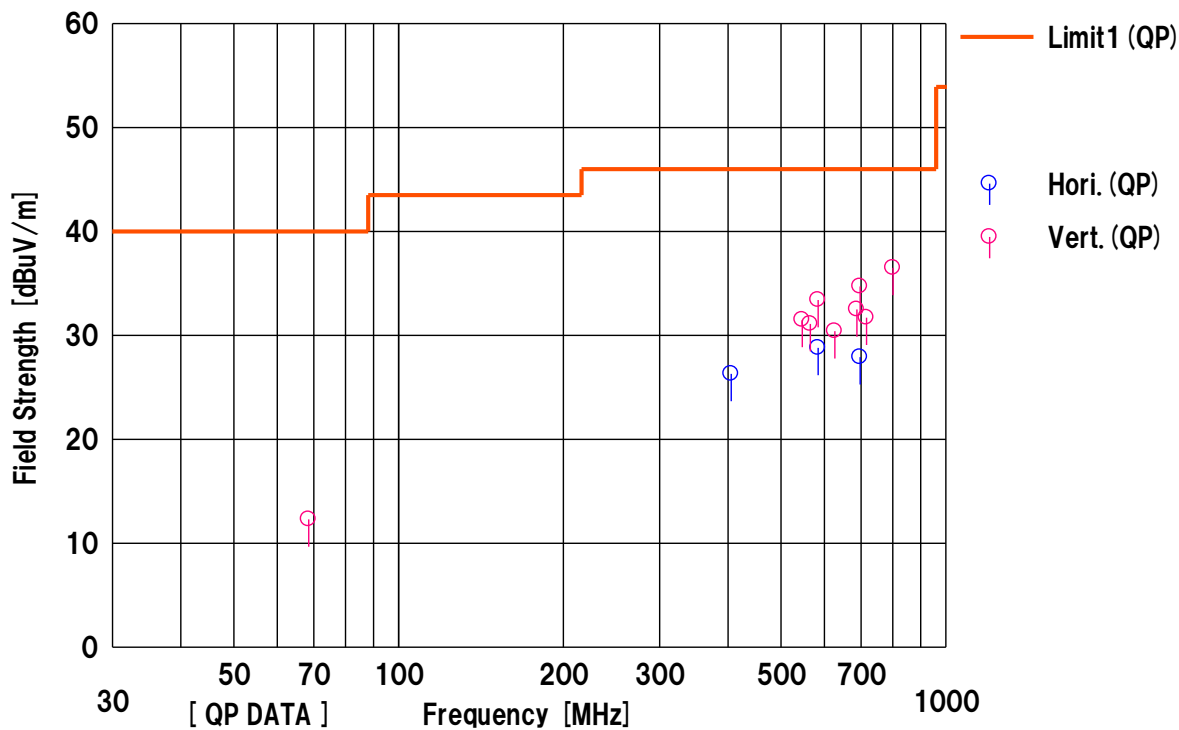

| Frequency [MHz] | Meter Reading (QP) [dBuV] | Antenna (Factor) [dB/m] | Cable Loss [dB] | Pre-AMP Gain [dB] | Result (QP) [dBuV/m] | Limit [dBuV/m] | Margin [dB] | pola  | Height [cm] | Angle [deg] |
|-----------------|---------------------------|-------------------------|-----------------|-------------------|----------------------|----------------|-------------|-------|-------------|-------------|
| 405.371         | 31.4                      | 19.6                    | 3.5             | 28.2              | 26.3                 | 46.0           | 19.7        | Hori. | 100         | 204         |
| 584.422         | 31.2                      | 22.0                    | 4.4             | 28.8              | 28.8                 | 46.0           | 17.2        | Hori. | 100         | 360         |
| 697.407         | 28.0                      | 23.5                    | 4.9             | 28.5              | 27.9                 | 46.0           | 18.1        | Hori. | 100         | 335         |
| 68.490          | 27.1                      | 12.4                    | 1.2             | 28.4              | 12.3                 | 40.0           | 27.7        | Vert. | 100         | 277         |
| 546.736         | 34.7                      | 21.4                    | 4.2             | 28.8              | 31.5                 | 46.0           | 14.5        | Vert. | 100         | 339         |
| 565.423         | 33.9                      | 21.7                    | 4.3             | 28.8              | 31.1                 | 46.0           | 14.9        | Vert. | 100         | 305         |
| 584.407         | 35.8                      | 22.0                    | 4.4             | 28.8              | 33.4                 | 46.0           | 12.6        | Vert. | 100         | 286         |
| 626.757         | 31.9                      | 22.6                    | 4.6             | 28.7              | 30.4                 | 46.0           | 15.6        | Vert. | 191         | 54          |
| 688.079         | 32.8                      | 23.4                    | 4.8             | 28.5              | 32.5                 | 46.0           | 13.5        | Vert. | 100         | 45          |
| 697.436         | 34.8                      | 23.5                    | 4.9             | 28.5              | 34.7                 | 46.0           | 11.3        | Vert. | 100         | 45          |
| 716.400         | 31.6                      | 23.6                    | 5.0             | 28.5              | 31.7                 | 46.0           | 14.3        | Vert. | 100         | 17          |
| 801.115         | 35.2                      | 24.1                    | 5.4             | 28.2              | 36.5                 | 46.0           | 9.5         | Vert. | 151         | 360         |

### 3.2 Radiated Emission 1 GHz - 6 GHz

Model Name : SIP Cordless Handset  
 Model No. : KX-TPA73  
 Serial No. : S11CA000052  
 Operator : E. Abe  
 Points : 7  
 Detector : PK/AV  
 RBW : 1 MHz

Test condition of instruments  
 Date : 2019/09/02  
 Temperature : 23 degree C  
 Humidity : 39 % 1015 hPa  
 EUT Warm-up Time : 30 minutes  
 Distance : 3 m  
 Test Mode : SP Phone Talk & BT Burst  
 Comment : AC 120 V / 60 Hz

The measurement was conducted in the condition where maximum emission was detected by the preliminary test.  
 Level=Emission Level=Meter Reading+ Factor (Antenna + Cable + Preamp)

LIMIT: FCC Part 15 Class B (3 m)  
 : ICES-003 Class B (3 m)

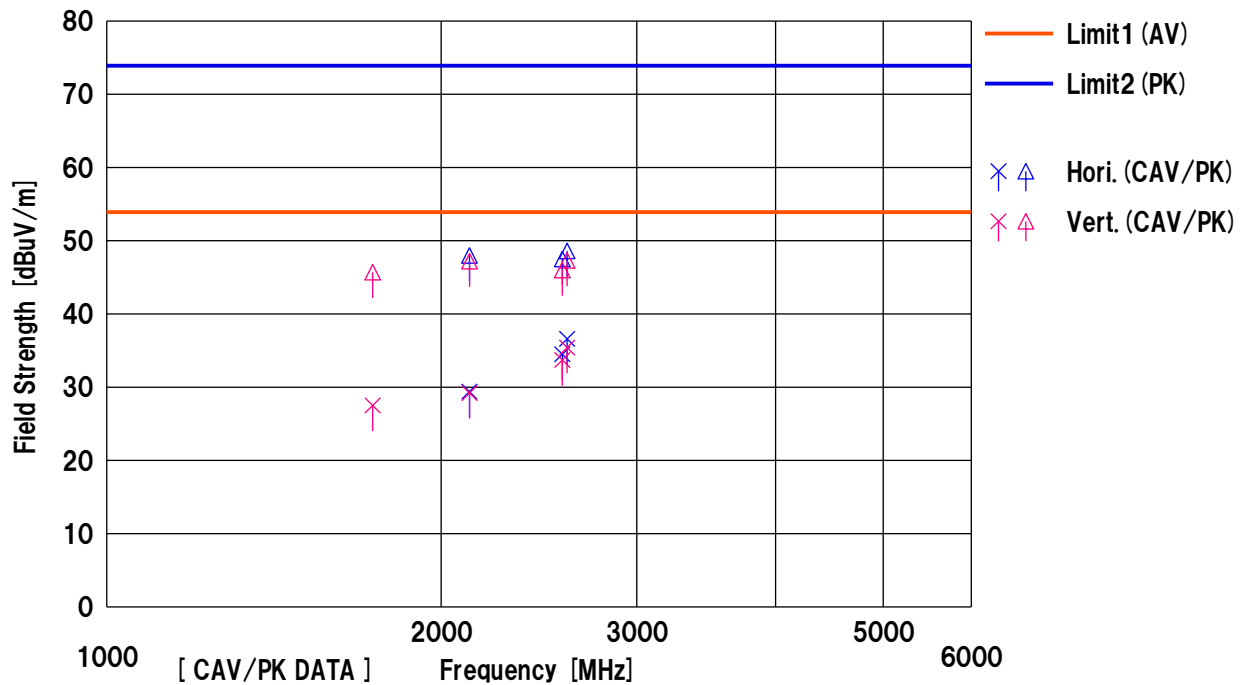

| Frequency [MHz] | Meter Reading |             | Factor         |      |           |     | Result        |               | Limit         |               | Margin    |           | Pola. | Height [cm] | Angle [deg] |
|-----------------|---------------|-------------|----------------|------|-----------|-----|---------------|---------------|---------------|---------------|-----------|-----------|-------|-------------|-------------|
|                 | (AV) [dBuV]   | (PK) [dBuV] | Antenna [dB/m] | Loss | Gain [dB] | D   | (AV) [dBuV/m] | (PK) [dBuV/m] | (AV) [dBuV/m] | (PK) [dBuV/m] | (AV) [dB] | (PK) [dB] |       |             |             |
| 2121.160        | 38.9          | 57.5        | 28.1           | 8.0  | 47.7      | 2.1 | 29.4          | 48.0          | 53.9          | 73.9          | 24.5      | 25.9      | Hori. | 100         | 191         |
| 2571.090        | 42.2          | 55.2        | 28.7           | 8.9  | 47.4      | 2.1 | 34.5          | 47.5          | 53.9          | 73.9          | 19.4      | 26.4      | Hori. | 100         | 176         |
| 2597.060        | 44.1          | 56.1        | 28.8           | 9.0  | 47.4      | 2.1 | 36.6          | 48.6          | 53.9          | 73.9          | 17.3      | 25.3      | Hori. | 100         | 178         |
| 1735.580        | 39.3          | 57.5        | 26.6           | 7.3  | 47.8      | 2.1 | 27.5          | 45.7          | 53.9          | 73.9          | 26.4      | 28.2      | Vert. | 100         | 360         |
| 2121.390        | 38.7          | 56.7        | 28.1           | 8.0  | 47.7      | 2.1 | 29.2          | 47.2          | 53.9          | 73.9          | 24.7      | 26.7      | Vert. | 100         | 340         |
| 2571.000        | 41.4          | 53.7        | 28.7           | 8.9  | 47.4      | 2.1 | 33.7          | 46.0          | 53.9          | 73.9          | 20.2      | 27.9      | Vert. | 313         | 191         |
| 2597.000        | 42.9          | 54.8        | 28.8           | 9.0  | 47.4      | 2.1 | 35.4          | 47.3          | 53.9          | 73.9          | 18.5      | 26.6      | Vert. | 100         | 221         |

D: Distance Factor

### 3.3 Conducted Emission

|            |                        |                               |                            |
|------------|------------------------|-------------------------------|----------------------------|
| Model Name | : SIP Cordless Handset | Test condition of instruments |                            |
| Model No.  | : KX-TPA73             | Date                          | : 2019/09/02               |
| Serial No. | : S11CA000052          | Temperature                   | : 24 degree C              |
| Operator   | : E. Abe               | Humidity                      | : 40 % 1015 hPa            |
| Points     | : 12                   | EUT Warm-up Time              | : 30 minutes               |
| Detector   | : QP/AV                | Test Mode                     | : SP Phone Talk & BT Burst |
| RBW        | : 9 kHz                | Comment                       | : AC 120 V / 60 Hz         |

The measurement was conducted in the condition where maximum emission was detected by the preliminary test.

Level=Emission Level=Meter Reading+ Factor (Cable + LISN)

Limit: FCC Part 15 Class B (QP), ICES-003 Class B (QP),

Limit: FCC Part 15 Class B (AV), ICES-003 Class B (AV)

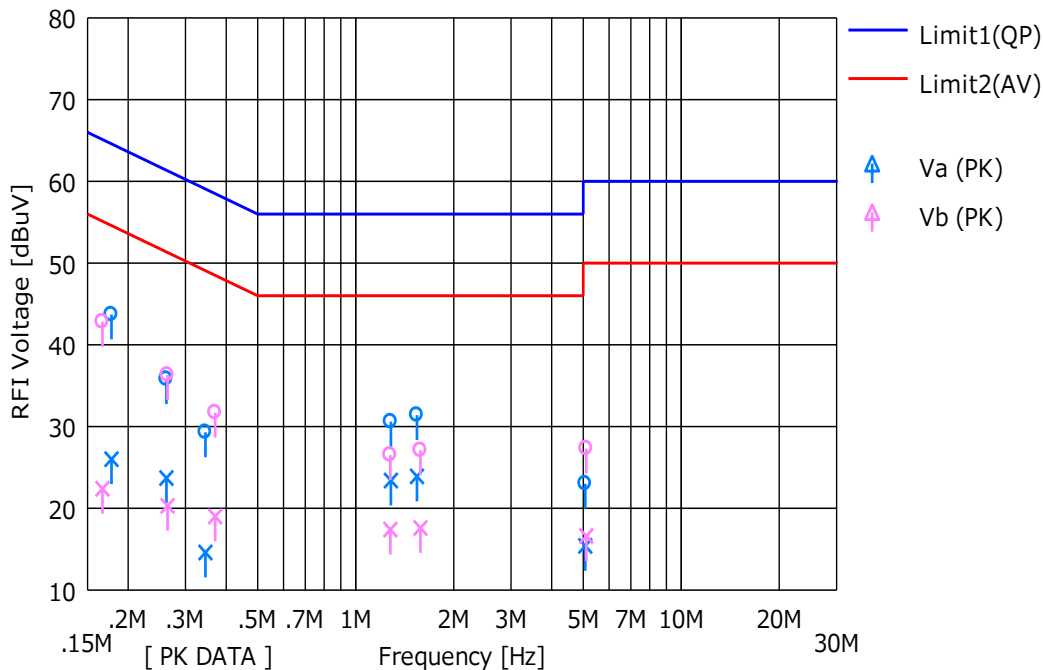

| Frequency [MHz] | Line | Meter Reading (QP) [dBuV] | Meter Reading (AV) [dBuV] | Factor [dB] | Result (QP) [dBuV] | Result (AV) [dBuV] | Limit (QP) [dBuV] | Limit (AV) [dBuV] | Margin (QP) [dB] | Margin (AV) [dB] |
|-----------------|------|---------------------------|---------------------------|-------------|--------------------|--------------------|-------------------|-------------------|------------------|------------------|
| 0.17775         | Va   | 33.1                      | 15.4                      | 10.6        | 43.7               | 26.0               | 64.6              | 54.6              | 20.9             | 28.6             |
| 0.26213         | Va   | 25.3                      | 13.2                      | 10.5        | 35.8               | 23.7               | 61.4              | 51.4              | 25.6             | 27.7             |
| 0.34533         | Va   | 18.8                      | 4.1                       | 10.5        | 29.3               | 14.6               | 59.1              | 49.1              | 29.8             | 34.5             |
| 1.28293         | Va   | 20.1                      | 12.9                      | 10.5        | 30.6               | 23.4               | 56.0              | 46.0              | 25.4             | 22.6             |
| 1.54200         | Va   | 20.9                      | 13.4                      | 10.5        | 31.4               | 23.9               | 56.0              | 46.0              | 24.6             | 22.1             |
| 5.07033         | Va   | 12.3                      | 4.7                       | 10.7        | 23.0               | 15.4               | 60.0              | 50.0              | 37.0             | 34.6             |
| 0.16674         | Vb   | 32.2                      | 11.8                      | 10.6        | 42.8               | 22.4               | 65.1              | 55.1              | 22.3             | 32.7             |
| 0.26428         | Vb   | 25.8                      | 9.8                       | 10.5        | 36.3               | 20.3               | 61.3              | 51.3              | 25.0             | 31.0             |
| 0.37011         | Vb   | 21.2                      | 8.5                       | 10.5        | 31.7               | 19.0               | 58.5              | 48.5              | 26.8             | 29.5             |
| 1.27748         | Vb   | 16.0                      | 6.9                       | 10.5        | 26.5               | 17.4               | 56.0              | 46.0              | 29.5             | 28.6             |
| 1.58078         | Vb   | 16.6                      | 7.1                       | 10.5        | 27.1               | 17.6               | 56.0              | 46.0              | 28.9             | 28.4             |
| 5.10913         | Vb   | 16.6                      | 5.9                       | 10.7        | 27.3               | 16.6               | 60.0              | 50.0              | 32.7             | 33.4             |

## SECTION 4. DESCRIPTION OF EUT

### 4.1 Construction of EUT

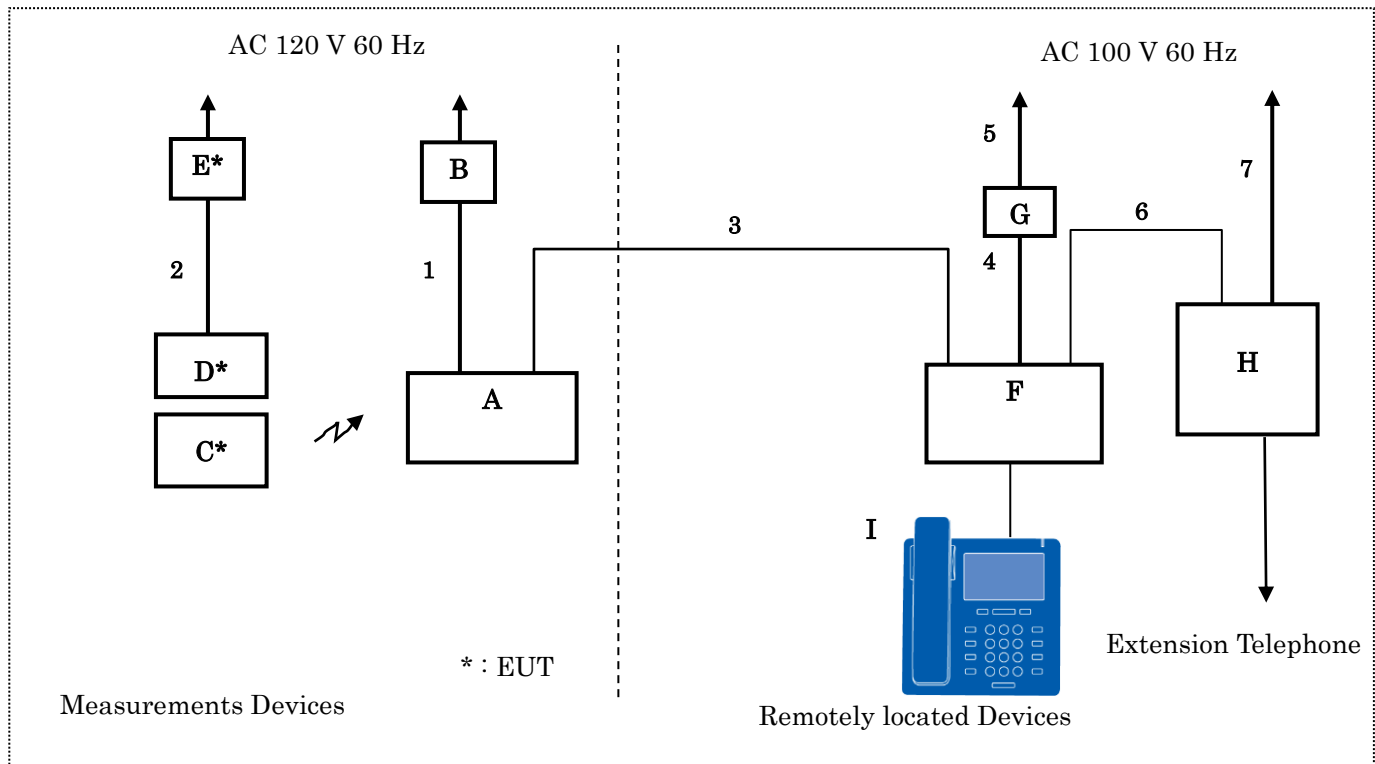

Symbol or number assigned to equipment or cables on this diagram is used on tables in section 4.2 and 4.3

### 4.2 EUT and Support Equipment Used

The EUT was supported by the following equipment during the test. Indication in the following left side column corresponds to section 4.1.

| Symbol | Item                             | Model No.  | [Manufacturer] | Serial No.        | FCC ID |
|--------|----------------------------------|------------|----------------|-------------------|--------|
| A      | Base Unit for SIP Cordless Phone | KX-TGP700  | [Panasonic]    | S11CA000008       | ---    |
| B      | AC Adapter for Base Unit         | PNLV236    | [Panasonic]    | IJ31EF4           | ---    |
| C      | SIP Cordless Handset (EUT)       | KX-TPA73   | [Panasonic]    | S11CA000052       | ---    |
| D      | Charger (EUT)                    | PNLC1090ZA | [Panasonic]    | S11CA000052       | ---    |
| E      | AC Adaptor for Charger (EUT)     | PQLV219    | [Panasonic]    | PU2017081400645   | ---    |
| F      | Hub                              | GS108PEv3  | [NETGEAR]      | 3UJ1535500F2F     | ---    |
| G      | AC Adaptor for Hub               | AD8190LF   | [NETGEAR]      | 311504191031708KT | ---    |
| H      | IP PBX                           | KX-NS1000  | [Panasonic]    | 4EACJ002521       | ---    |
| I      | IP Proprietary Telephone         | KX-NT630NE | [Panasonic]    | S21CA000138       | ---    |

#### 4.3 Cable(s) Used

The following cable(s) was used for the test. Indication number in the following left side column corresponds to section 4.1

| No. | Name                           | Length | Shield/<br>Unshielded | Connector | Ferrite Core |
|-----|--------------------------------|--------|-----------------------|-----------|--------------|
| 1   | DC Cable for Base Unit         | 1.8 m  | Unshielded            | Plastic   | None         |
| 2   | DC Cable for Charger           | 1.8 m  | Unshielded            | Plastic   | None         |
| 3   | LAN Cable                      | 100 m  | Unshielded            | Plastic   | None         |
| 4   | DC Cable for PoE Hub           | 1.5 m  | Unshielded            | Plastic   | None         |
| 5   | AC Cable for PoE Hub (3 Wires) | 2.0 m  | Unshielded            | Plastic   | None         |
| 6   | LAN Cable                      | 0.9 m  | Unshielded            | Plastic   | None         |
| 7   | AC Cable (3 Wires)             | 1.8 m  | Unshielded            | Plastic   | None         |
| 8   | LAN Cable                      | 1.5 m  | Unshielded            | Plastic   | None         |

#### 4.4 Operating Condition(s)

The EUT was operated under the following condition during the test.

| Mode     | Condition                           | Handset powered by |
|----------|-------------------------------------|--------------------|
| I        | Handset Talk & Burst                | Battery            |
| J        | Headset Talk & Burst                | Battery            |
| K        | SP Phone Talk & Burst               | Battery            |
| L        | Handset Talk & Burst                | N/A                |
| M        | Headset Talk & Burst                | AC Adaptor         |
| <b>N</b> | <b>SP Phone Talk &amp; BT Burst</b> | <b>AC Adaptor</b>  |
| S1       | Standby                             | AC Adaptor         |
| S2       | Standby                             | Battery            |

#### 4.5 Any Deviations from, Additions to or Exclusions from the Test Method

No deviation

#### 4.6 Modifications to EUT

No modification was performed by the test laboratory during the test.

**SECTION 6. TEST INSTRUMENTS LIST****6.1 Radiated Emission (30 MHz - 1000 MHz)**

| No. | Apparatus                | Model No.<br>(Manufacturer)                     | Specification                          | Calibration              |                    | Serial No.          |
|-----|--------------------------|---|--|--------------------------|--------------------|---------------------|
|     |                          |   |  | Date                     | Interval           |                     |
| 1*  | Power Supply             | 4430, 4421<br>(NF)                              | 50 Hz / 60 Hz<br>4 kVA<br>264 V        | ---                      | ---                | 302261<br>305364    |
| 2*  | Antenna                  | VHA9103/BBA9106<br>UHALP9108-A<br>(Schwarzbeck) | 30 MHz - 300 MHz<br>300 MHz - 1000 MHz | 2018/05/29<br>2018/05/29 | 2 years<br>2 years | VHA91032274<br>0620 |
| 3*  | Pre-Amplifier            | 8447D<br>(hp)                                   | 0.1 MHz - 1.3 GHz                      | 2019/01/07               | 1 year             | 2944A09179          |
| 4*  | EMI<br>Test Receiver     | ESR26<br>(R&S)                                  | CISPR 16-1-1<br>9 kHz - 26.5 GHz       | 2018/10/18               | 1 year             | 101243              |
| 5*  | Personal<br>Computer     | OPTIPLEX 3060<br>(DELL)                         | ---                                    | ---                      | ---                | 5RMS0W2             |
| 6*  | Measurement<br>Software  | TEPTO-DV-RE<br>(tsj)                            | ---                                    | ---                      | ---                | V.2.6.0208          |
| 7*  | 3 dB Attenuator          | CFA-01<br>(TME)                                 | 3 dB<br>DC - 1 GHz                     | 2018/05/29               | 2 years            | EMF-683             |
| 8*  | 6 dB Attenuator          | MP721B<br>(Anritsu)                             | 6 dB<br>DC - 12 GHz                    | 2018/05/29               | 2 years            | M45998              |
| 9*  | SW Box                   | NS4903N<br>(TOYO)                               | ---                                    | 2019/04/11               | 1 year             | EMF-372             |
| 10* | Cables                   | ---   | 30 MHz - 1000 MHz                      | 2019/04/11               | 1 year             | EMF-524             |
| 11* | Semi-Anechoic<br>Chamber | 3 m method(NSA)<br>(RIKEN)                      | 30 MHz - 1000 MHz                      | 2019/07/28               | 1 year             | ELF-002             |

\* Used for final test

**6.2 Radiated Emission (1 GHz - 6 GHz)**

| No. | Apparatus                                | Model No.<br>(Manufacturer)     | Specification                    | Calibration |          | Serial No.       |
|-----|--|---------------------------------|----------------------------------|-------------|----------|------------------|
|     |  |                                 |                                  | Date        | Interval |                  |
| 1*  | Power Supply                             | 4430, 4421<br>(NF)              | 50 Hz / 60 Hz<br>4 kVA<br>264 V  | ---         | ---      | 302261<br>305364 |
| 2*  | Antenna                                  | 3115<br>(EMCO)                  | 1 GHz - 18 GHz                   | 2019/02/15  | 2 years  | 00044715         |
| 3*  | Pre-Amplifier                            | MLA-0118-J02<br>(tsj)           | 1 GHz - 18 GHz<br>Gain > 45 dB   | 2018/10/23  | 1 year   | 19325            |
| 4*  | EMI<br>Test Receiver                     | ESR26<br>(R&S)                  | CISPR 16-1-1<br>9 kHz - 26.5 GHz | 2018/10/18  | 1 year   | 101243           |
| 5*  | Personal<br>Computer                     | OPTIPLEX 3060<br>(DELL)         | ---                              | ---         | ---      | 5RMS0W2          |
| 6*  | Measurement<br>Software                  | TEPTO-DV-RE<br>(tsj)            | ---                              | ---         | ---      | V.2.6.0208       |
| 7*  | Absorber                                 | PFP30<br>(RIKEN)                | ---                              | ---         | ---      | ---              |
| 8*  | Cables                                   | SUCOFLEX 102A<br>(HUBER+SUHNER) | 1 GHz - 6 GHz                    | 2019/02/06  | 1 year   | EMF-587          |
| 9*  | SW Box                                   | NS4903N<br>(TOYO)               | ---                              | 2019/02/06  | 1 year   | EMF-372          |
| 10* | Band Rejection Filter<br>(DECT 1.9 GHz)  | BRC20053<br>(MICRO-TRONICS)     | 1 GHz - 5 GHz                    | 2019/08/23  | 2 years  | 001<br>EMF-710   |
| 11* | Band Rejection Filter<br>(2.4 GHz Wi-Fi) | BRC20054<br>(MICRO-TRONICS)     | 1 GHz - 6 GHz                    | 2019/08/23  | 2 years  | 001<br>EMF-711   |
| 12* | Semi-Anechoic<br>Chamber                 | 3 m method(Svswr)<br>(RIKEN)    | 1 GHz - 6 GHz                    | 2019/05/18  | 1 year   | ELF-002          |

\* Used for final test

## 6.3 Conducted Emission

| No. | Apparatus               | Model No.<br>(Manufacturer) | Specification                   | Calibration |          | Serial No.   |
|-----|-------------------------|-----------------------------|---------------------------------|-------------|----------|--------------|
|     |                         |                             |                                 | Date        | Interval |              |
| 1*  | Power Supply            | ES040ES<br>(NF)             | 50 Hz / 60 Hz<br>4 kVA<br>264 V | ---         | ---      | 9244357      |
| 2*  | Attenuator              | 6910.01.A<br>(HUBER+SUHNER) | 10 dB<br>0.15 MHz - 30 MHz      | 2018/12/11  | 2 years  | EMF-051-3    |
| 3*  | AMN                     | KNW-407<br>(Kyoritsu)       | 250 V / 15 A                    | 2018/12/11  | 2 years  | 8-1345-4     |
| 4*  | AMN                     | KNW-242C<br>(Kyoritsu)      | 9 kHz - 30 MHz                  | 2018/09/05  | 2 years  | 8-1312-2     |
| 5*  | EMI<br>Test Receiver    | ESCI<br>(R&S)               | CISPR 16-1-1<br>9 kHz - 3 GHz   | 2019/02/07  | 1 year   | 100812       |
| 6*  | Personal Computer       | ProDesk 600 G2 SFF<br>(hp)  | ---                             | ---         | ---      | JPH642HK9Q   |
| 7*  | Measurement<br>Software | TEPTO-DV/RE<br>(tsj)        | ---                             | ---         | ---      | Ver.3.1.0029 |
| 8*  | RF Fuse                 | MP612A<br>(Anritsu)         | ---                             | 2018/10/04  | 1 year   | EMF-389      |
| 9*  | Cable                   | ---                         | 0.15 MHz - 30 MHz               | 2018/10/04  | 1 year   | EMF-532      |
| 10* | 50 ohm<br>Terminator    | 65 N-50-0-1/133<br>(SUHNER) | 50 ohm                          | 2019/07/30  | 2 years  | EMF-658      |
| 11* | Shielded Room           | ---<br>(RIKEN)              | 0.15 MHz - 30 MHz               | ---         | ---      | ELF-001      |

\* Used for final test

## SECTION 7. TEST PROCEDURE(s)

### 7.1 Radiated Emission

#### 7.1.1 Measurement system

##### Equipment Set-up (Refer to section 4 and 5)

##### Tabletop Equipment

The EUT is placed on the table of size, 0.5 m(d) by 1.5 m(w), raised 0.8 m above the metal ground plane (turn table). The table is made of styrene foam.

##### Interconnecting Cables

The cables that hang closer than 40 cm to the ground plane is folded back and forth forming bundle 30 to 40 cm long, hanging in the middle between the ground plane and the table approximately.

The measurement is conducted the worst emissions condition.

##### Turn Table

The turn table is capable for EUT weight and rotatable 0 to 360 degree horizontally by remote control in the measurement room.

##### Antenna Mast

The antenna mast is attachable to all antennas described on section 6 and antenna height is adjustable 1 to 4 meters continuously by remote control at the measurement room, and antenna polarization is also changed by the remote control. Especially for 1 GHz to 40 GHz measurement antenna tilt angle is adjustable by remote control at the measurement room to keep the antenna in the “cone of radiation” of EUT.

##### Test Equipment (refer to section 6.1 and 6.2)

##### Test Facilities (30 MHz to 1 GHz)

The radiated emission test site is validated by measurements of the attenuation of signals propagated over the site and compared with theoretical attenuation of signals propagated over an ideal site. Horizontally and vertically polarized attenuation measurements are made over the frequency range of 30 MHz to 1 GHz. These measurements are made in accordance with the procedures of D.2 and/or D.3, as applicable of Annex D in the ANSI C63.4-2014 standard, and the results are normalized for comparison with the theoretical attenuation values.

##### Test Facilities (1 GHz to 40 GHz)

The test site complies with the  $S_{VSWR}$  requirements specified in 8.3.2 of CISPR 16-1-4:2010-04 over the frequency range of 1 GHz to 18 GHz, when tested in accordance with the site validation procedures requirements specified in 8.3.3 of CISPR 16-1-4:2010-04. Additionally, the RF absorbing materials used on the reference ground plane have a maximum height (thickness) of 30 cm (12 in) and have a minimum-rated attenuation of 20 dB (at normal incidence) at all frequencies from 1 GHz to 18 GHz.

## **7.1.2 Test Procedure**

### **7.1.2.1 Preliminary Measurement**

The EUT is tested on all operating conditions.

The spectrum analyzer is set max-hold mode and swept during turntable is rotated 0 to 360 degree and antenna is moving 1 to 4 meter height. Then spectrum chart is plotted out to detect the worst conditions in configuration, operating mode and/or ambient noise notation.

### **7.1.2.2 Final Measurement**

The EUT is operated in the condition where maximum emission is detected by the preliminary test.

EMI Test Receiver is used for final measurement. The turntable azimuth (EUT direction) and antenna height are adjusted the position so that maximum field strength is obtained for each frequency spectrum to be measured. Especially for 1 GHz to 40 GHz measurement antenna tilt angle are adjusted to obtain the maximum field strength.

The equipment and cables are arranged or manipulated within the range of the test standard in the above condition.

## 7.2 Conducted Emission

### 7.2.1 Measurement system

#### Equipment Set-up (Refer to section 4 and 5)

##### Tabletop Equipment

EUT is placed on EUT table of size, 1.0m(d) by 1.5m(w), raised 0.8m above the metal ground plane and 0.4 m from vertical metal plane.

##### Interconnecting Cables

Excess part of the interconnecting cables longer than 1 meter are bundled in the center.

Cables that hang closer than 40 cm to the ground plane are folded back and forth forming bundle 30 to 40 cm long, hanging approx. in the middle between ground plane and table.

The measurement was conducted the worst emissions condition.

##### AC Power Cord

AC power cord for the EUT is connected to one LISN which is placed on the ground plane. The LISN is placed in 80 cm from the nearest part of EUT chassis.

The excess power cable is bundled in the center, or shortened to appropriate length.

AC cables except from the EUT are connected second LISN.

##### LISN

The chassis of the LISN is placed on the metal ground plane maintaining the direct current resistance of less than or equal to 2.5m ohm. The lead to be tested is selectable by switch, and the terminals which are not connected to the EUT are terminated in 50 ohm resistor termination.

#### Test Equipment (refer to section 6.3)

### 7.2.2 Test Procedure

#### 7.2.2.1 Preliminary Measurement

The EUT is tested on all operating conditions.

The spectrum analyzer is set max-hold mode and swept till no variation. Then spectrum chart is plotted out to detect the worst conditions in configuration and/or operating mode. All cables except for safety grounded are tested.

#### 7.2.2.2 Final Measurement

The EUT is operated in the condition where maximum emission is detected by the preliminary test.

EMI Test Receiver is used for final measurement. The equipment and cables are arranged or manipulated within the range of the test standard in the above condition.