



## EMI TEST REPORT

Test Report No. : 26DE0101-HO-2a

Applicant : Panasonic Communications Co., Ltd.  
Type of Equipment : Cordless Telephone (Baset) (sic)  
Model No. : KX-TG5771  
FCC ID : ACJ96NKX-TG5771  
Test standard : FCC Part 15 Subpart C  
Section 15.207, Section 15.247 : 2005  
Test Result : Complied

1. This test report shall not be reproduced in full or partial, without the written approval of UL Apex Co., Ltd.
2. The results in this report apply only to the sample tested.
3. This equipment is in compliance with the above regulation. We hereby certify that the data contain a true representation of the EMC profile.
4. The test results in this report are traceable to the national or international standards.

Date of test: November 13 to 23, 2005

Tested by:



Takumi Shimada  
EMC Services



Makoto Kosaka  
EMC Services



Norihisa Hashimoto  
EMC Services

Approved by:

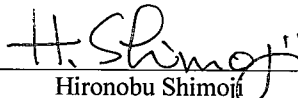

Hironobu Shimoji  
Group Leader of  
EMC Services

UL Apex Co., Ltd.

Head Office EMC Lab.

4383-326 Asama-cho, Ise-shi, Mie-ken 516-0021 JAPAN

Telephone : +81 596 24 8116

Facsimile : +81 596 24 8124

MF060b(01.06.05)

<b>CONTENTS</b>	<b>PAGE</b>
SECTION 1: Client information .....	3
SECTION 2: Equipment under test (E.U.T.).....	3
SECTION 3: Test specification, procedures & results.....	5
SECTION 4: Operation of E.U.T. during testing .....	8
SECTION 5: Conducted Emission.....	9
SECTION 6: Spurious Emission .....	10
SECTION 7: Bandwidth .....	11
SECTION 8: Maximum Peak Output Power .....	11
SECTION 9: Carrier Frequency Separation .....	11
SECTION 10: Number of Hopping Frequency .....	11
SECTION 11: Dwell time.....	11
APPENDIX 1: Photographs of test setup .....	12
Conducted Emission .....	12
Spurious Emission (Radiated) .....	14
Worst Case Position (Horizontal: 0-deg/ Vertical: 90-deg, Left Antenna).....	15
APPENDIX 2: Test instruments .....	16
APPENDIX 3: Data of EMI test.....	17
Conducted Emission .....	17
Carrier Frequency Separation .....	25
20dB Bandwidth .....	27
Number of Hopping Frequency.....	29
Dwell time .....	31
Maximum Peak Output Power .....	33
Radiated Spurious Emission(30MHz-1GHz) .....	36
Radiated Spurious Emission(1GHz-40GHz) .....	39
Conducted Spurious Emission.....	42

## SECTION 1: Client information

Company Name	Panasonic Communications Co., Ltd.
Brand name	Panasonic
Address	1-62, 4-chome, Minoshima, Hakata-ku, Fukuoka, 812-8531 Japan
Telephone Number	+81-92-477-1405
Facsimile Number	+81-92-477-1487
Contact Person	Kunihiko Nawata

## SECTION 2: Equipment under test (E.U.T.)

### 2.1 Identification of E.U.T.

Type of Equipment	Cordless Telephone (Baset)
Model No.	KX-TG5771
Serial No.	1 (for Radiated emissions and Conducted emissions) 2 (for Antenna terminal conducted emissions)
Country of Manufacture	Japan
Rating	AC120V 60Hz (AC Adaptor: POLV205)
Condition of EUT	Engineering prototype (Not for sale: This sample is equivalent to mass-produced items.)
Operation Clock	Main clock: 13.824 MHz
Receipt Date of Sample	November 11, 2005

### 2.2 Product Description

Equipment Type	Transceiver
Frequency band	Lower limit= 5725MHz, Upper limit= 5850MHz
Bandwidth & Channel spacing	Bandwidth: 79MHz Channel spacing: 891.87kHz
Type of Modulation	FHSS
Antenna Type	Colliner-Antenna
Antenna Connector Type	N/A
Antenna Gain	3dBi (Typ.)
Mode of Operation	Duplex
ITU code	F1E
Power Supply (RF Part)	DC 4.0V
Method of Frequency Generation	Synthesizer

**UL Apex Co., Ltd.**

**Head Office EMC Lab.**

4383-326 Asama-cho, Ise-shi, Mie-ken 516-0021 JAPAN

Telephone : +81 596 24 8116

Facsimile : +81 596 24 8124

MF060b(01.06.05)

**FCC 15.31 (e)**

This EUT provides stable voltage (DC4.0V) constantly to RF Module regardless of input voltage. Therefore, this EUT complies with the requirement.

**FCC Part 15.203 Antenna requirement**

It is impossible for end users to replace the antenna, because the antenna is fixed outside of the EUT. Therefore, the equipment complies with the antenna requirement of Section 15.203.

---

**UL Apex Co., Ltd.**

**Head Office EMC Lab.**

4383-326 Asama-cho, Ise-shi, Mie-ken 516-0021 JAPAN

Telephone : +81 596 24 8116

Facsimile : +81 596 24 8124

MF060b(01.06.05)

### **SECTION 3: Test specification, procedures & results**

#### **3.1 Test Specification**

Test Specification : FCC Part15 Subpart C : 2005

Title : FCC 47CFR Part15 Radio Frequency Device Subpart C Intentional Radiators  
Section 15.207 Conducted limits : 2005  
Section 15.247 Operation within the bands 902-928MHz,  
2400-2483.5MHz, and 5725-5850MHz : 2005

### 3.2 Procedures and results

No.	Item	Test Procedure	Specification	Remarks	Deviation	Worst Margin*0)	Results
1	Conducted emission	ANSI C63.4:2003 7. AC powerline conducted emission measurements	Section 15.207	-	N/A	11.4dB 0.54135MHz AV, L	Complied
2	Carrier Frequency Separation	ANSI C63.4:2003 13. Measurement of intentional radiators	Section 15.247(a)(1)	Conducted	N/A	See data.	Complied
3	20dB Bandwidth	ANSI C63.4:2003 13. Measurement of intentional radiators	Section 15.247(a)(1)	Conducted	N/A		Complied
4	Number of Hopping Frequency	ANSI C63.4:2003 13. Measurement of intentional radiators	Section 15.247(a)(1)(iii)	Conducted	N/A		Complied
5	Dwell time	ANSI C63.4:2003 13. Measurement of intentional radiators	Section 15.247(a)(1)(iii)	Conducted	N/A		Complied
6	Maximum Peak Output Power	ANSI C63.4:2003 13. Measurement of intentional radiators	Section 15.247(b)(1)	Conducted	N/A		Complied
7	Band Edge Compliance	ANSI C63.4:2003 13. Measurement of intentional radiators	Section 15.247(d)	Conducted	N/A		Complied
8	Spurious Emission	ANSI C63.4:2003 13. Measurement of intentional radiators	Section 15.247(d)	Conducted/ Radiated	N/A	5.7dB 5852.0MHz PK, Ver.	Complied

Note: UL Apex's EMI Work Procedures No. QPM05 and QPM15.

\*0) The result is rounded off to the second decimal place. Therefore, there may be 0.1 difference for the result.

**Uncertainty:**

Conducted Emission

The measurement uncertainty (with a 95% confidence level) for this test is  $\pm 1.3$ dB.  
The data listed in this test report has enough margin, more than the site margin.

Spurious Emission (Radiated)

The measurement uncertainty (with a 95% confidence level) for this test using Biconical antenna is  $\pm 4.5$ dB(3m)/  $\pm 4.7$ dB(10m).  
The measurement uncertainty (with a 95% confidence level) for this test using Logperiodic antenna is  $\pm 5.2$ dB(3m)/  $\pm 3.8$ dB(10m).  
The measurement uncertainty (with a 95% confidence level) for this test using Horn antenna is  $\pm 6.6$ dB.  
The data listed in this report meets the limits unless the uncertainty is taken into consideration.

Other test except Conducted Emission and Spurious Emission (Radiated)

The measurement uncertainty (with a 95% confidence level) for this test is  $\pm 3.0$ dB.

\*These tests were also referred to FCC Public Notice DA 00-705 "Guidance on Measurement for Frequency Hopping Spread Spectrum Systems".

\*These tests were performed without any deviations from test procedure except for additions or exclusions.

**UL Apex Co., Ltd.**

**Head Office EMC Lab.**

4383-326 Asama-cho, Ise-shi, Mie-ken 516-0021 JAPAN

Telephone : +81 596 24 8116

Facsimile : +81 596 24 8124

MF060b(01.06.05)

### 3.3 Test Location

UL Apex Co., Ltd. Head Office EMC Lab. \*NVLAP Lab. code: 200572-0  
4383-326 Asama-cho, Ise-shi, Mie-ken 516-0021 JAPAN  
Telephone : +81 596 24 8116  
Facsimile : +81 596 24 8124

	FCC Registration Number	IC Registration Number	Width x Depth x Height (m)	Size of reference ground plane (m) / horizontal conducting plane	Other rooms
No.1 semi-anechoic chamber	313583	IC4247A	19.2 x 11.2 x 7.7m	7.0 x 6.0m	Preparation room
No.2 semi-anechoic chamber	846015	IC4247A-2	7.5 x 5.8 x 5.2m	4.0 x 4.0m	-
No.3 shielded room	-	-	4.7 x 7.5 x 2.7m	4.7 x 7.5m	-
No.4 measurement room	-	-	3.1 x 5.0 x 2.7m	N/A	-

\* Size of vertical conducting plane (for Conducted Emission test) : 2.0 x 2.0m for No.1 and No.2 semi-anechoic and No.3 shielded room.

### 3.4 Test set up, Test instruments and Data of EMI

Refer to APPENDIX 1 to 3.

## **SECTION 4: Operation of E.U.T. during testing**

### **4.1 Operating Modes**

The mode is used : [FHSS]  
Transmitting mode  
Low Channel : 5759.70240MHz  
Mid Channel : 5798.05084MHz  
High Channel : 5838.18697MHz

### **4.2 Configuration and peripherals**

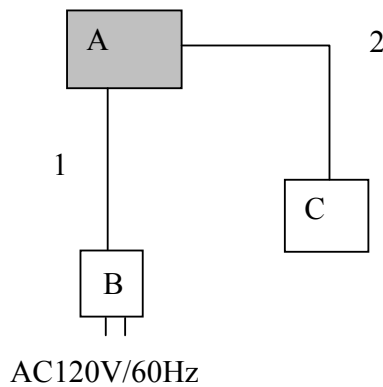

\* Cabling was taken into consideration and test data was taken under worse case conditions.

#### **Description of EUT and Support equipment**

No.	Item	Model number	Serial number	Manufacturer	FCC ID
A	Cordless Telephone (Baset)	KX-TG5771	1 (for Radiated and Conducted emissions) 2 (for Antenna terminal conducted emissions)	Panasonic Communications	ACJ96NKX-TG5771
B	AC Adapter	PQLV205	-	Panasonic Communications	-
C	Facsimile Equipment	FQ-70	17104455	Sharp	-

#### **List of cables used**

No.	Name	Length (m)	Shield
1	DC Cable	2.0	N
2	Tel Code	1.8	N

**UL Apex Co., Ltd.**

**Head Office EMC Lab.**

4383-326 Asama-cho, Ise-shi, Mie-ken 516-0021 JAPAN

Telephone : +81 596 24 8116

Facsimile : +81 596 24 8124

MF060b(01.06.05)

## **SECTION 5: Conducted Emission**

### **Test Procedure and conditions**

EUT was placed on a platform of nominal size, 0.5m by 1.0m, raised 80cm above the conducting ground plane. The rear of tabletop was located 40cm to the vertical conducting plane. The rear of EUT, including peripherals aligned and flushed with rear of tabletop. All other surfaces of tabletop were at least 80cm from any other grounded conducting surface. EUT was located 80cm from a Line Impedance Stabilization Network (LISN)/ Artificial mains Network (AMN) and excess AC cable was bundled in center.

#### For the tests on EUT itself (as a stand alone equipment)

Each EUT current-carrying power lead, except the ground (safety) lead, was individually connected through a LISN/(AMN) to the input power source. All unused 50ohm connectors of the LISN(AMN) were resistivity terminated in 50ohm when not connected to the measuring equipment.

The AC Mains Terminal Continuous disturbance Voltage has been measured with the EUT in a Semi Anechoic Chamber or a Measurement Room.

The EUT was connected to a LISN (AMN).

An overview sweep with peak detection has been performed.

**Detector** : CISPR quasi-peak and average detector (IF BW 9 kHz)  
**Measurement range** : 0.15-30MHz  
**Test data** : APPENDIX 3  
**Test result** : Pass

---

**UL Apex Co., Ltd.**

**Head Office EMC Lab.**

4383-326 Asama-cho, Ise-shi, Mie-ken 516-0021 JAPAN

Telephone : +81 596 24 8116

Facsimile : +81 596 24 8124

MF060b(01.06.05)

## **SECTION 6: Spurious Emission**

### **[Conducted]**

#### **Test Procedure**

The Out of Band Emission was measured with a spectrum analyzer connected to the antenna port.

**Test data** : APPENDIX 3

**Test result** : Pass

### **[Radiated]**

#### **Test Procedure**

EUT was placed on a platform of nominal size, 0.5m by 1.0m, raised 80cm above the conducting ground plane.

The Radiated Electric Field Strength intensity has been measured in a Semi Anechoic Chamber with a ground plane and at a distance of 3m(Below 18GHz) and 1m(Upper 18GHz) and 0.5m (Upper 26.5GHz).

The height of the measuring varied between 1 and 4m and EUT was rotated a full revolution in order to obtain the maximum value of the electric field intensity.

The measurements were performed for both vertical and horizontal antenna polarization with the Test Receiver, or the Spectrum Analyzer (in linear mode).

The test was made with the detector (RBW/VBW) in the following table.

When using Spectrum analyzer, the test was made with adjusting span to zero by using peak hold.

In any 100kHz bandwidth outside the frequency band in which the spread spectrum intentional radiator is operating, the radio frequency power that is produced by the intentional radiator confirmed 20dB below that in the 100kHz bandwidth within the band that contains the highest level of the desired power, based on a radiated measurement.

#### **20dBc was applied to the frequency over the limit of FCC 15.209 and outside the restricted band of 15.205.**

Frequency	Below 1GHz	Above 1GHz
Instrument used	Test Receiver / Spectrum Analyzer	Spectrum Analyzer
Detector	QP: BW 120kHz(T/R)	PK: RBW:1MHz/VBW: 1MHz
IF Bandwidth	20dBc : RBW: 100kHz VBW: 300kHz (S/A)	AV: RBW:1MHz/VBW:10Hz 20dBc : RBW:100kHz/VBW:300kHz

- The test was made on EUT at the normal use position.

**Test data** : APPENDIX 3

**Test result** : Pass

---

**UL Apex Co., Ltd.**

**Head Office EMC Lab.**

4383-326 Asama-cho, Ise-shi, Mie-ken 516-0021 JAPAN

Telephone : +81 596 24 8116

Facsimile : +81 596 24 8124

MF060b(01.06.05)

## **SECTION 7: Bandwidth**

### **Test Procedure**

The bandwidth was measured with a spectrum analyzer connected to the antenna port.

Test data : APPENDIX 3  
Test result : Pass

## **SECTION 8: Maximum Peak Output Power**

### **Test Procedure**

The Maximum Peak Output Power was measured with a spectrum analyzer connected to the antenna port.

Test data : APPENDIX 3  
Test result : Pass

## **SECTION 9: Carrier Frequency Separation**

### **Test Procedure**

The carrier frequency separation was measured with a spectrum analyzer connected to the antenna port.

Test data : APPENDIX 3  
Test result : Pass

## **SECTION 10: Number of Hopping Frequency**

### **Test Procedure**

The Number of Hopping Frequency was measured with a spectrum analyzer connected to the antenna port.

Test data : APPENDIX 3  
Test result : Pass

## **SECTION 11: Dwell time**

### **Test Procedure**

The Dwell time was measured with a spectrum analyzer connected to the antenna port.

Test data : APPENDIX 3  
Test result : Pass

---

**UL Apex Co., Ltd.**

**Head Office EMC Lab.**

4383-326 Asama-cho, Ise-shi, Mie-ken 516-0021 JAPAN

Telephone : +81 596 24 8116

Facsimile : +81 596 24 8124

MF060b(01.06.05)

**APPENDIX 1: Photographs of test setup**

**Conducted Emission**  
**With Battery Charging**  
**Front**



**Rear**



**Conducted Emission**  
Without Battery Charging  
**Front**



**Rear**



### Spurious Emission (Radiated)

Front



Rear



**Worst Case Position (Horizontal: 0-deg/ Vertical: 90-deg, Left Antenna)**

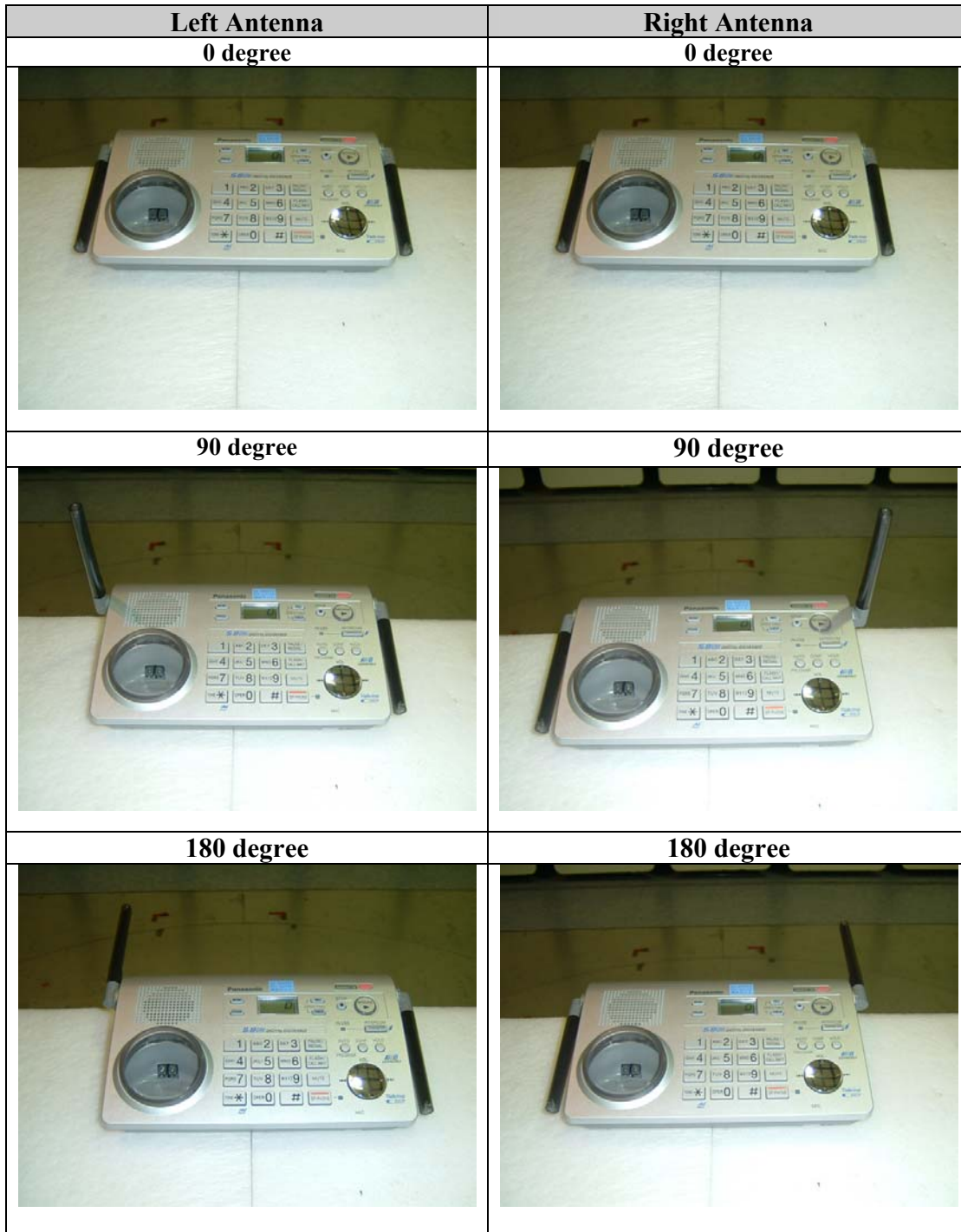

## **APPENDIX 2:Test instruments**

### **EMI test equipment**

<b>Control No.</b>	<b>Instrument</b>	<b>Manufacturer</b>	<b>Model No</b>	<b>Test Item</b>	<b>Calibration Date * Interval(month)</b>
MAEC-02	Anechoic Chamber	TDK	Semi Anechoic Chamber 3m	RE	2005/04/11 * 12
MRENT-21	Spectrum Analyzer	Advantest	R3273	RE	2005/08/19 * 12
MCC-04	Microwave Cable 1G-50GHz	Storm	421-011 ( 90-1394-079 )	RE	2005/01/05 * 12
MCC-47	Microwave Cable 1G-26.5GHz	Suhner	SUCOFLEX104	RE	2005/08/30 * 12
MHA-06	Horn Antenna	Schwarzbeck	BBHA9120D	RE	2005/01/10 * 12
MPA-01	Pre Amplifier	Agilent	8449B	RE	2005/02/05 * 12
MAT-22	Attenuator(10dB)( above1GHz)	Orient Microwave	BX10-0476-00	RE	2005/03/16 * 12
MCC-12	Coaxial Cable	Fujikura/Agilent	-	RE	2005/02/24 * 12
MBA-01	Biconical Antenna	Schwarzbeck	BBA9106	RE	2005/10/10 * 12
MLA-01	Logperiodic Antenna	Schwarzbeck	USLP9143	RE	2005/10/14 * 12
MAT-07	Attenuator(6dB)	Weinschel Corp	2	RE	2004/12/16 * 12
MPA-09	Pre Amplifier	Agilent	8447D	RE	2005/09/07 * 12
MLS-06	LISN(AMN)	Schwarzbeck	NSLK8127	CE(EUT)	2005/02/04 * 12
MLS-07	LISN(AMN)	Schwarzbeck	NSLK8127	CE(AE)	2005/02/04 * 12
MCC-13	Coaxial Cable	Fujikura/Agilent	-	CE	2005/02/24 * 12
MTA-06	Termination	MCL	BTRM-50	CE	2005/02/03 * 12
MSA-03	Spectrum Analyzer	Agilent	E4448A	AT	2005/09/16 * 12
MBF-03	SHF Bandpass Filter	M-City	13GHz BPF	RE	2005/05/20 * 12
MHA-02	Horn Antenna	EMCO	3160-09	RE	2005/01/10 * 12
MSA-04	Spectrum Analyzer	Agilent	E4448A	RE	2005/05/19 * 12
MHA-04	Horn Antenna	EMCO	3160-10	RE	2005/01/10 * 12
MCC-27	Microwave Cable 1G-50GHz	Suhner	SUCOFLEX101	RE	2005/08/30 * 12
MPA-03	Microwave System Power Amplifier	Agilent	83050A	RE	2005/05/11 * 12

**All equipment is calibrated with traceable calibrations. Each calibration is traceable to the national or international standards.**

**Test Item:**

- CE: Conducted Emission**
- RE: Radiated Spurious Emission**
- AT: Antenna Terminal Measurement**

**UL Apex Co., Ltd.**

**Head Office EMC Lab.**

4383-326 Asama-cho, Ise-shi, Mie-ken 516-0021 JAPAN

Telephone : +81 596 24 8116

Facsimile : +81 596 24 8124

MF060b(01.06.05)

**APPENDIX 3: Data of EMI test**

**Conducted Emission**  
(With Battery Charging)

**DATA OF CONDUCTED EMISSION TEST**

UL Apex Co., Ltd. Head Office EMC Lab. No.2 Semi Anechoic Chamber  
Date : 2005/11/14 22:57:00

Applicant : Panasonic Communications Co., Ltd      Report No. : 26DE0101-HO  
 Kind of EUT : Basetel      Power : AC120V/60Hz (AC Adapter)  
 Model No. : KX-TG5771      Temp./Humi. : 24deg. C / 38%  
 Serial No. : 1      Operator : Takumi Shimada

Mode / Remarks : Tx5759.70240MHz / Ant:Left(Worst) / With Battery charging

LIMIT : FCC15C §15.207 (QP) / RSS-Gen  
 FCC15C §15.207 (AV) / RSS-Gen

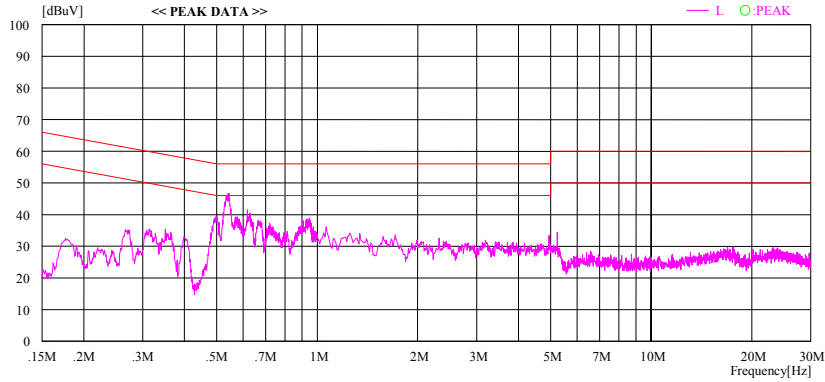
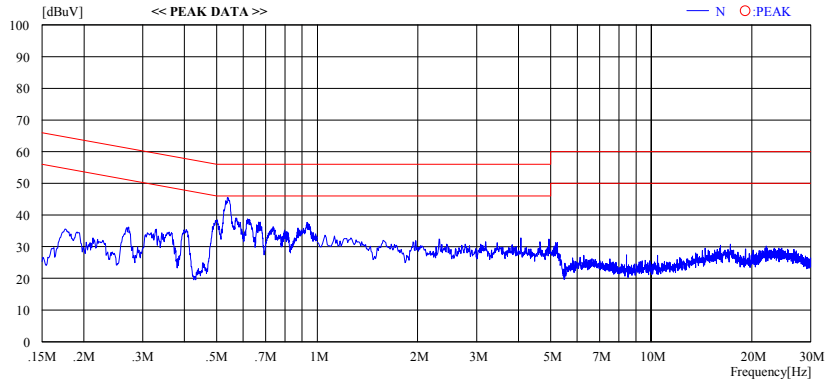

CHART: WITH FACTOR, Peak hold data. Data is uncorrected. CALCULATION: RESULT=READING+C.F (LISN LOSS+CABLE LOSS)  
Except for the above table : adequate margin data below the limits.

**Conducted Emission**  
 (With Battery Charging)

DATA OF CONDUCTED EMISSION TEST

UL Apex Co., Ltd. Head Office EMC Lab. No.2 Semi Anechoic Chamber  
 Date : 2005/11/14 23:26:17

Applicant	: Panasonic Communications Co., Ltd	Report No.	: 26DE0101-HO
Kind of EUT	: BaseSet	Power	: AC120V/60Hz (AC Adapter)
Model No.	: KX-TG5771	Temp./Humi.	: 24deg. C / 38%
Serial No.	: 1	Operator	: Takumi Shimada

Mode / Remarks : Tx5798.5084MHz / Ant:Left(Worst) / With Battery charging

LIMIT : FCC15C §15.207 (QP) / RSS-Gen  
 FCC15C §15.207 (AV) / RSS-Gen

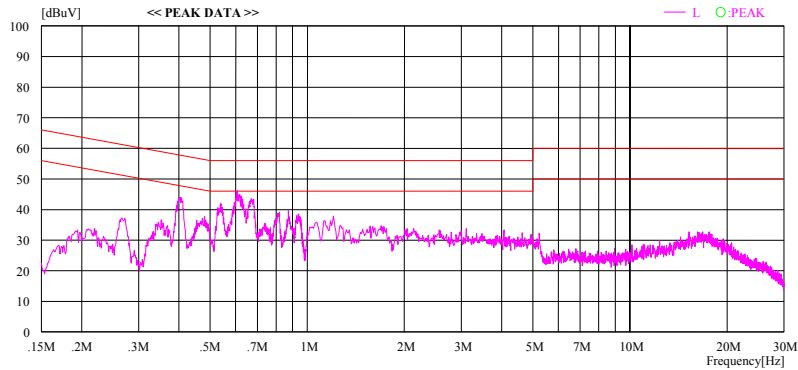
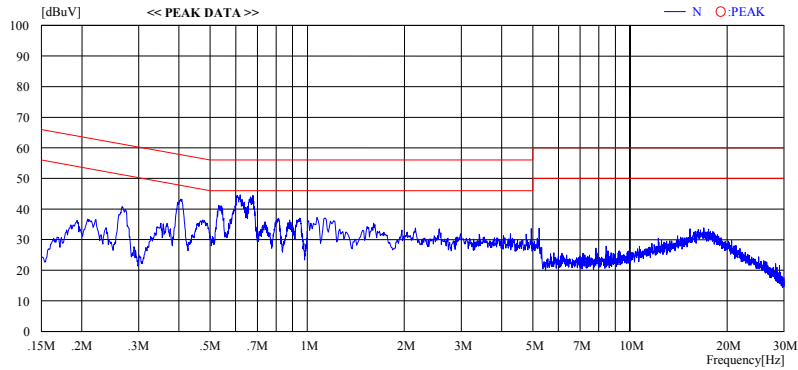

CHART: WITH FACTOR, Peak hold data. Data is uncorrected. CALCULATION: RESULT=READING+C.F (L ISN LOSS+CABLE LOSS)  
 Except for the above table : adequate margin data below the limits.

**Conducted Emission**  
 (With Battery Charging)

**DATA OF CONDUCTED EMISSION TEST**

UL Apex Co., Ltd. Head Office EMC Lab. No.2 Semi Anechoic Chamber  
 Date : 2005/11/15 00:19:11

Applicant : Panasonic Communications Co., Ltd      Report No. : 26DE0101-HO  
 Kind of EUT : BaseSet      Power : AC120V/60Hz (AC Adapter)  
 Model No. : KX-TG5771      Temp./Humi. : 24deg. C / 38%  
 Serial No. : 1      Operator : Takumi Shimada

Mode / Remarks : Tx5838.18697MHz / Ant:Left(Worst) / With Battery charging

LIMIT : FCC15C §15.207 (QP) / RSS-Gen  
 FCC15G §15.207 (AV) / RSS-Gen

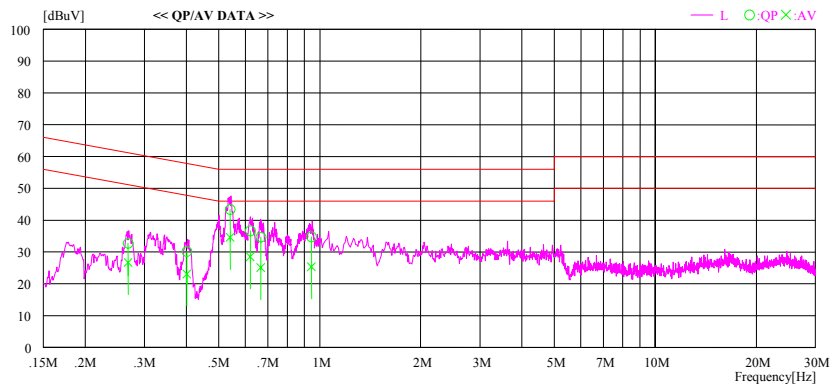
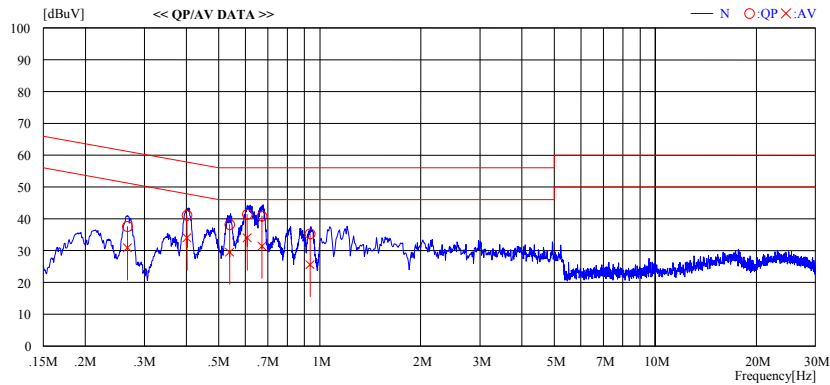

CHART: WITH FACTOR, Peak hold data. Data is uncorrected. CALCURATION: RESULT=READING+C. F (LISN LOSS+CABLE LOSS)  
 Except for the above table : adequate margin data below the limits.

**Conducted Emission**  
 (With Battery Charging)

DATA OF CONDUCTED EMISSION TEST

UL Apex Co., Ltd. Head Office EMC Lab. No.2 Semi Anechoic Chamber  
 Date : 2005/11/15 00:19:11

Applicant : Panasonic Communications Co., Ltd      Report No. : 26DE0101-HO  
 Kind of EUT : BaseSet      Power : AC120V/60Hz (AC Adapter)  
 Model No. : KX-TG5771      Temp./Humi. : 24deg. C / 38%  
 Serial No. : 1      Operator : Takumi Shimada

Mode / Remarks : Tx5838.18697MHz / Ant:Left(Worst) / With Battery charging

LIMIT : FCC15C §15.207 (QP) / RSS-Gen  
 FCC15C §15.207 (AV) / RSS-Gen

Frequency [MHz]	Reading Level		Corr. Factor	Results		Limit		Margin		Phase
	QP [dBuV]	AV [dBuV]		QP [dBuV]	AV [dBuV]	QP [dBuV]	AV [dBuV]	QP [dB]	AV [dB]	
0.26725	37.5	30.8	0.1	37.6	30.9	61.2	51.2	23.6	20.3	N
0.40176	41.0	33.9	0.1	41.1	34.0	57.8	47.8	16.7	13.8	N
0.53865	38.0	29.3	0.2	38.2	29.5	56.0	46.0	17.8	16.5	N
0.60750	41.2	33.8	0.2	41.4	34.0	56.0	46.0	14.6	12.0	N
0.67216	40.6	31.2	0.2	40.8	31.4	56.0	46.0	15.2	14.6	N
0.93590	35.0	25.3	0.3	35.3	25.6	56.0	46.0	20.7	20.4	N
0.26836	32.6	26.6	0.1	32.7	26.7	61.2	51.2	28.5	24.5	L
0.40120	30.1	23.0	0.1	30.2	23.1	57.8	47.8	27.6	24.7	L
0.54135	43.2	34.4	0.2	43.4	34.6	56.0	46.0	12.6	11.4	L
0.62035	36.5	28.3	0.2	36.7	28.5	56.0	46.0	19.3	17.5	L
0.66729	34.5	24.9	0.2	34.7	25.1	56.0	46.0	21.3	20.9	L
0.94443	34.5	25.1	0.3	34.8	25.4	56.0	46.0	21.2	20.6	L

CHART: WITH FACTOR. Peak hold data. Data is uncorrected. CALCURATION: RESULT=READING+C.F (L ISN LOSS+CABLE LOSS)  
 Except for the above table: adequate margin data below the limits.

**Conducted Emission**  
 (Without Battery Charging)

**DATA OF CONDUCTED EMISSION TEST**

UL Apex Co., Ltd. Head Office EMC Lab. No.2 Semi Anechoic Chamber  
 Date : 2005/11/14 23:06:53

Applicant	: Panasonic Communications Co., Ltd	Report No.	: 26DE0101-HO
Kind of EUT	: BaseSet	Power	: AC120V/60Hz (AC Adapter)
Model No.	: KX-TG5771	Temp./Humi.	: 24deg. C / 38%
Serial No.	: 1	Operator	: Takumi Shimada

Mode / Remarks : Tx5759.70240MHz / Ant:Left(Worst) /

LIMIT : FCC15C § 15.207 (QP) / RSS-Gen  
 FCC15C § 15.207 (AV) / RSS-Gen

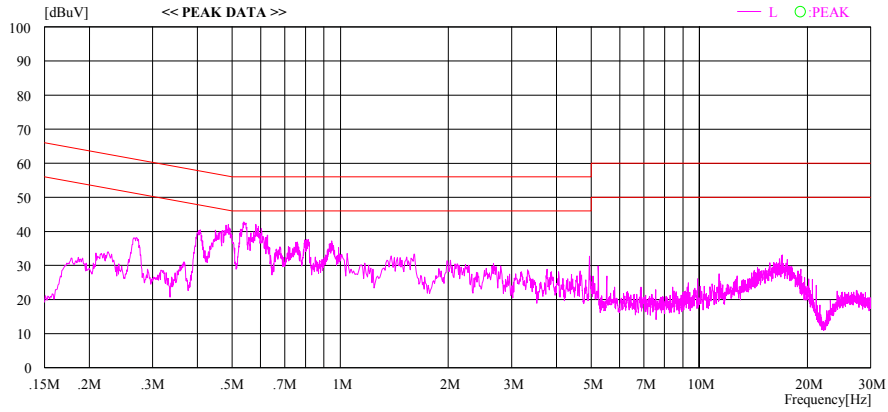
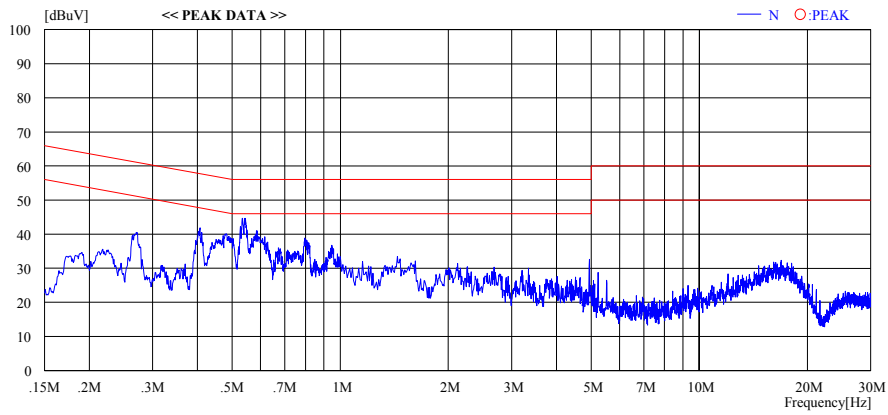

CHART: WITH FACTOR, Peak hold data. Data is uncorrected. CALCURATION: RESULT=READING+C.F(L I S N LOSS+CABLE LOSS)  
 Except for the above table : adequate margin data below the limits.

## Conducted Emission (Without Battery Charging)

### DATA OF CONDUCTED EMISSION TEST

UL Apex Co., Ltd. Head Office EMC Lab. No.2 Semi Anechoic Chamber  
Date : 2005/11/14 23:17:48

Applicant	: Panasonic Communications Co., Ltd	Report No.	: 26DE0101-HO
Kind of EUT	: BaseSet	Power	: AC120V/60Hz (AC Adapter)
Model No.	: KX-TG5771	Temp./Humi.	: 24deg.C / 38%
Serial No.	: 1	Operator	: Takumi Shimada

Mode / Remarks : Tx5798.5084MHz / Ant:Left(Worst) /

LIMIT : FCC15C §15.207 (QP) / RSS-Gen  
FCC15C §15.207 (AV) / RSS-Gen

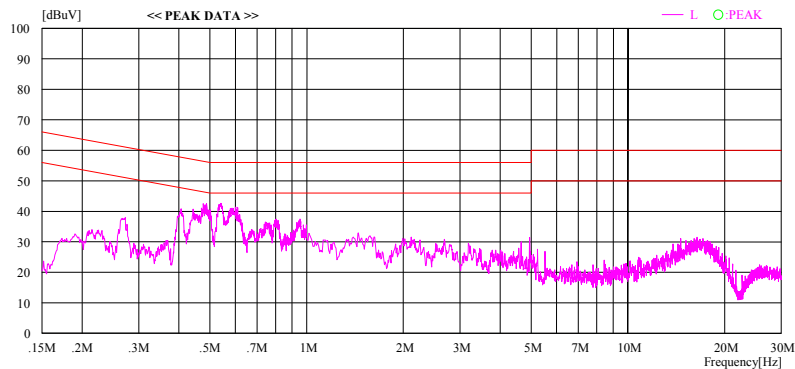
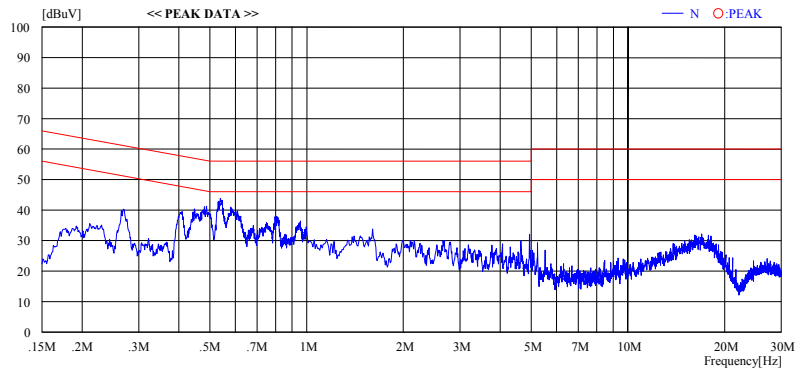

CHART: WITH FACTOR. Peak hold data. Data is uncorrected. CALCURATION: RESULT=READING+C. F (LISN LOSS+CABLE LOSS)  
Except for the above table : adequate margin data below the limits.

**Conducted Emission**  
 (Without Battery Charging)

**DATA OF CONDUCTED EMISSION TEST**

UL Apex Co., Ltd. Head Office EMC Lab. No.2 Semi Anechoic Chamber  
 Date : 2005/11/14 23:47:13

Applicant	: Panasonic Communications Co., Ltd	Report No.	: 26DE0101-HO
Kind of EUT	: Base set	Power	: AC120V/60Hz (AC Adapter)
Model No.	: KX-TG5771	Temp./Humi.	: 24deg. C / 38%
Serial No.	: 1	Operator	: Takumi Shimada

Mode / Remarks : Tx5838.18697MHz / Ant:Left(Worst) /

LIMIT : FCC15C §15.207 (QP) / RSS-Gen  
 FCC15C §15.207 (AV) / RSS-Gen

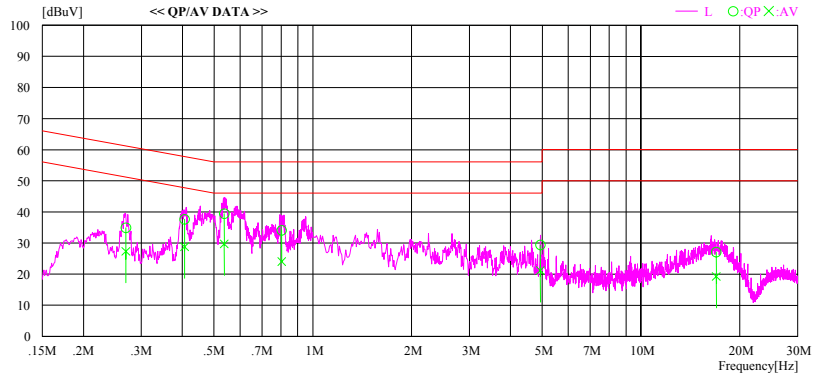
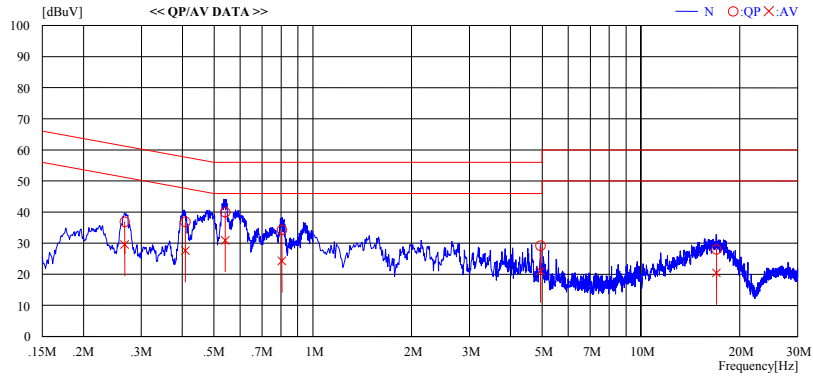

CHART: WITH FACTOR. Peak hold data. Data is uncorrected. CALCURATION: RESULT=READING+C.F.(LISN LOSS+CABLE LOSS)  
 Except for the above table : adequate margin data below the limits.

**Conducted Emission**  
 (Without Battery Charging)

**DATA OF CONDUCTED EMISSION TEST**

UL Apex Co., Ltd. Head Office EMC Lab. No. 2 Semi Anechoic Chamber  
 Date : 2005/11/14 23:47:13

Applicant : Panasonic Communications Co., Ltd      Report No. : 26DE0101-HO  
 Kind of EUT : BaseSet      Power : AC120V/60Hz (AC Adapter)  
 Model No. : KX-TG5771      Temp./Humi. : 24deg. C / 38%  
 Serial No. : 1      Operator : Takumi Shimada

Mode / Remarks : Tx5838.18697MHz / Ant:Left(Worst) /

LIMIT : FCC15C § 15.207 (QP) / RSS-Gen  
           FCC15C § 15.207 (AV) / RSS-Gen

Frequency [MHz]	Reading Level		Corr. Factor [dB]	Results		Limit		Margin		Phase
	QP [dBuV]	AV [dBuV]		QP [dBuV]	AV [dBuV]	QP [dBuV]	AV [dBuV]	QP [dB]	AV [dB]	
0.26716	36.8	29.5	0.1	36.9	29.6	61.2	51.2	24.3	21.6	N
0.40887	36.8	27.5	0.1	36.9	27.6	57.7	47.7	20.8	20.1	N
0.54093	39.8	30.7	0.2	40.0	30.9	56.0	46.0	16.0	15.1	N
0.80557	34.0	24.0	0.3	34.3	24.3	56.0	46.0	21.7	21.7	N
4.94089	28.4	20.2	0.8	29.2	21.0	56.0	46.0	26.8	25.0	N
16.97781	26.3	18.7	1.7	28.0	20.4	60.0	50.0	32.0	29.6	N
0.26977	34.8	27.2	0.1	34.9	27.3	61.1	51.1	26.2	23.8	L
0.40664	37.5	28.7	0.1	37.6	28.8	57.7	47.7	20.1	18.9	L
0.53768	39.2	29.5	0.2	39.4	29.7	56.0	46.0	16.6	16.3	L
0.80408	33.8	23.7	0.3	34.1	24.0	56.0	46.0	21.9	22.0	L
4.93906	28.6	20.3	0.8	29.4	21.1	56.0	46.0	26.6	24.9	L
16.98072	25.4	17.5	1.7	27.1	19.2	60.0	50.0	32.9	30.8	L

CHART: WITH FACTOR. Peak hold data. Data is uncorrected. CALCULATION: RESULT=READING+C. F (LISN LOSS+CABLE LOSS)  
 Except for the above table : adequate margin data below the limits.

## Carrier Frequency Separation

UL Apex Co., Ltd.  
Head Office EMC Lab. No.3 Shielded Room

COMPANY	: Panasonic Communications Co.,Ltd.	REGULATION	: FCC Part15 Subpart C 15.247(a)(1)
EQUIPMENT	: Cordless Telephone (Baset)	TEST DISTANCE	: -
MODEL	: KX-TG5771	DATE	: 11/17/2005
S/N	: 2	TEMPERATURE	: 24deg.C
POWER	: AC 120 V / 60Hz	HUMIDITY	: 29%
MODE	: Tx(Hopping on)	ENGINEER	: Makoto Kosaka

Ch	Freq. [MHz]	Channel separation [MHz]	Limit
Low	5759.7	0.889	>20dB Bandwidth and 25[kHz]
Mid	5798.1	0.889	>20dB Bandwidth and 25[kHz]
High	5838.2	0.889	>20dB Bandwidth and 25[kHz]

### Carrier Frequency Separation

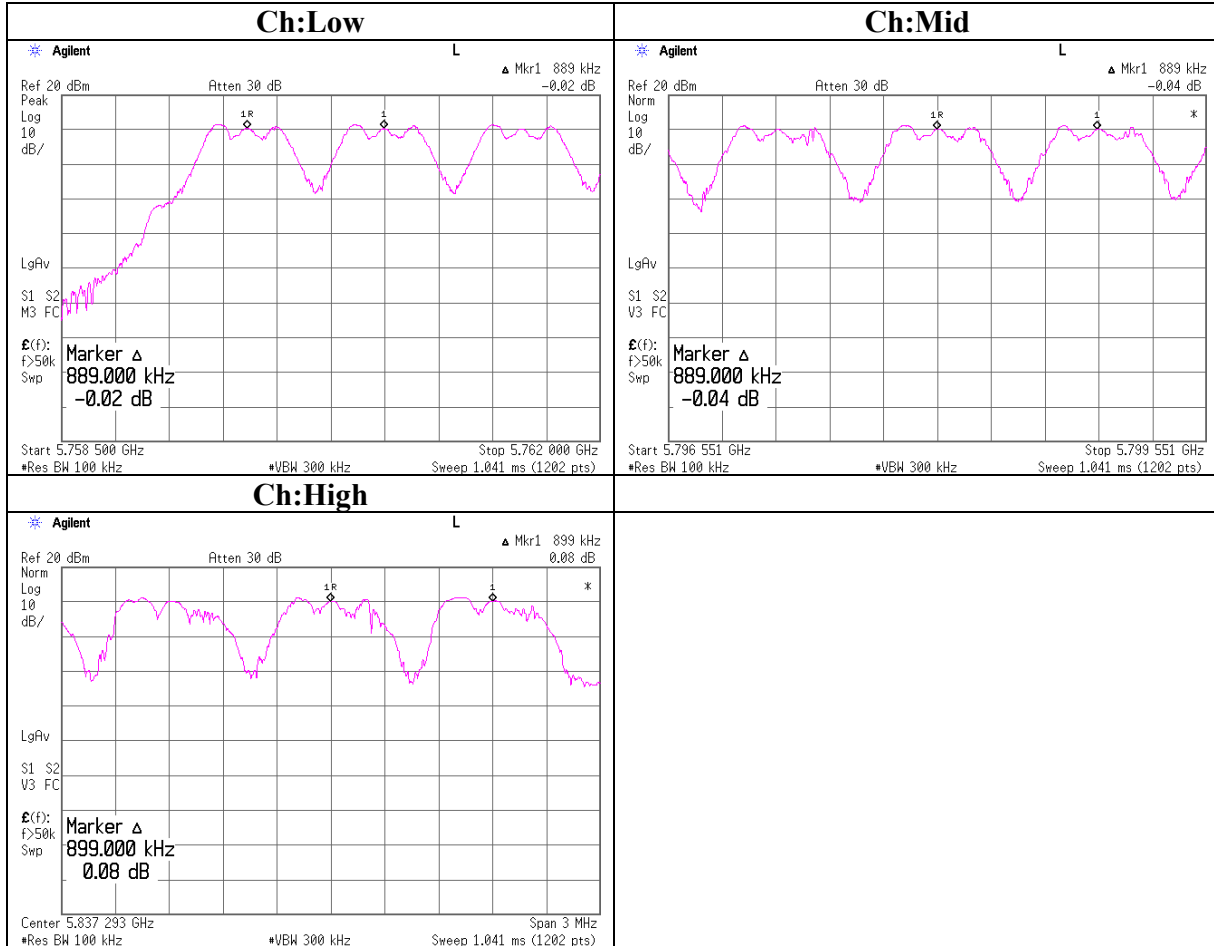

## 20dB Bandwidth

UL Apex Co., Ltd.  
Head Office EMC Lab. No.3 Shielded Room

COMPANY	: Panasonic Communications Co.,Ltd.	REGULATION	: FCC Part15 Subpart C 15.247(a)(1)(ii)
EQUIPMENT	: Cordless Telephone (Baset)	TEST DISTANCE	: -
MODEL	: KX-TG5771	DATE	: 11/17/2005
S/ N	: 2	TEMPERATURE	: 24deg.C
POWER	: AC 120 V / 60Hz	HUMIDITY	: 29%
MODE	: Tx(Hopping off)	ENGINEER	: Makoto Kosaka
	: Worst antenna		

### Left antenna

Ch	Freq. [MHz]	20dB Bandwidth [MHz]	Limit [MHz]
Low	5759.7	0.658	≦ 1
Mid	5798.1	0.674	≦ 1
High	5838.2	0.689	≦ 1

**20dB Bandwidth**

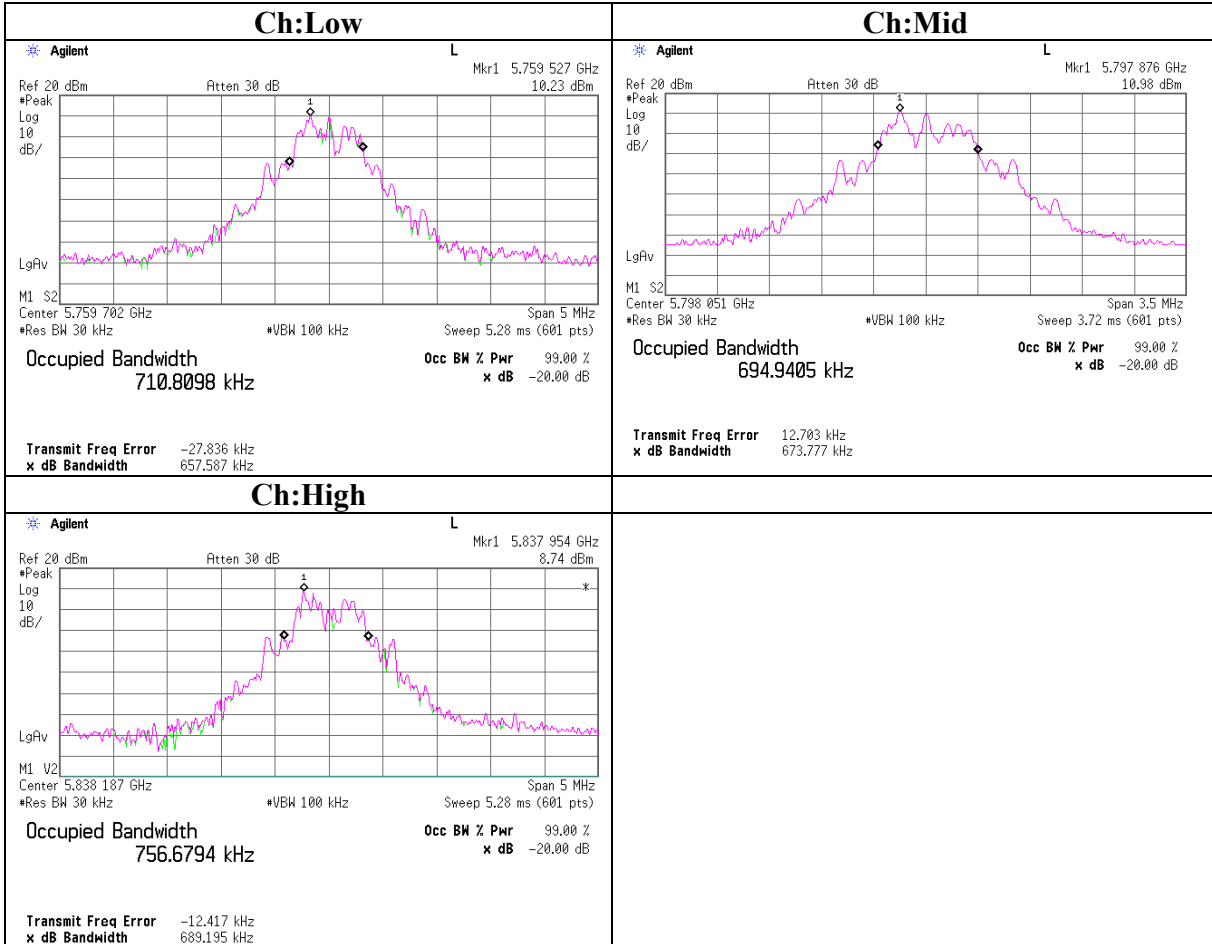

### Number of Hopping Frequency

UL Apex Co., Ltd.  
Head Office EMC Lab. No.3 Shielded Room

COMPANY : Panasonic Communications      REGULATION : FCC Part15 Subpart C 15.247(a)(1)(ii)  
EQUIPMENT : Cordless Telephone (Baset)      TEST DISTANCE : -  
MODEL : KX-TG5771      DATE : 11/17/2005  
S/ N : 2      TEMPERATURE : 24deg.C  
POWER : AC 120 V / 60Hz      HUMIDITY : 29%  
MODE : Tx(Hopping on)      ENGINEER : Makoto Kosaka

Mode	Number of channel [time]	Limit [time]
Tx(Hoppng on)	75	$\geq 75$

**Number of Hopping Frequency**

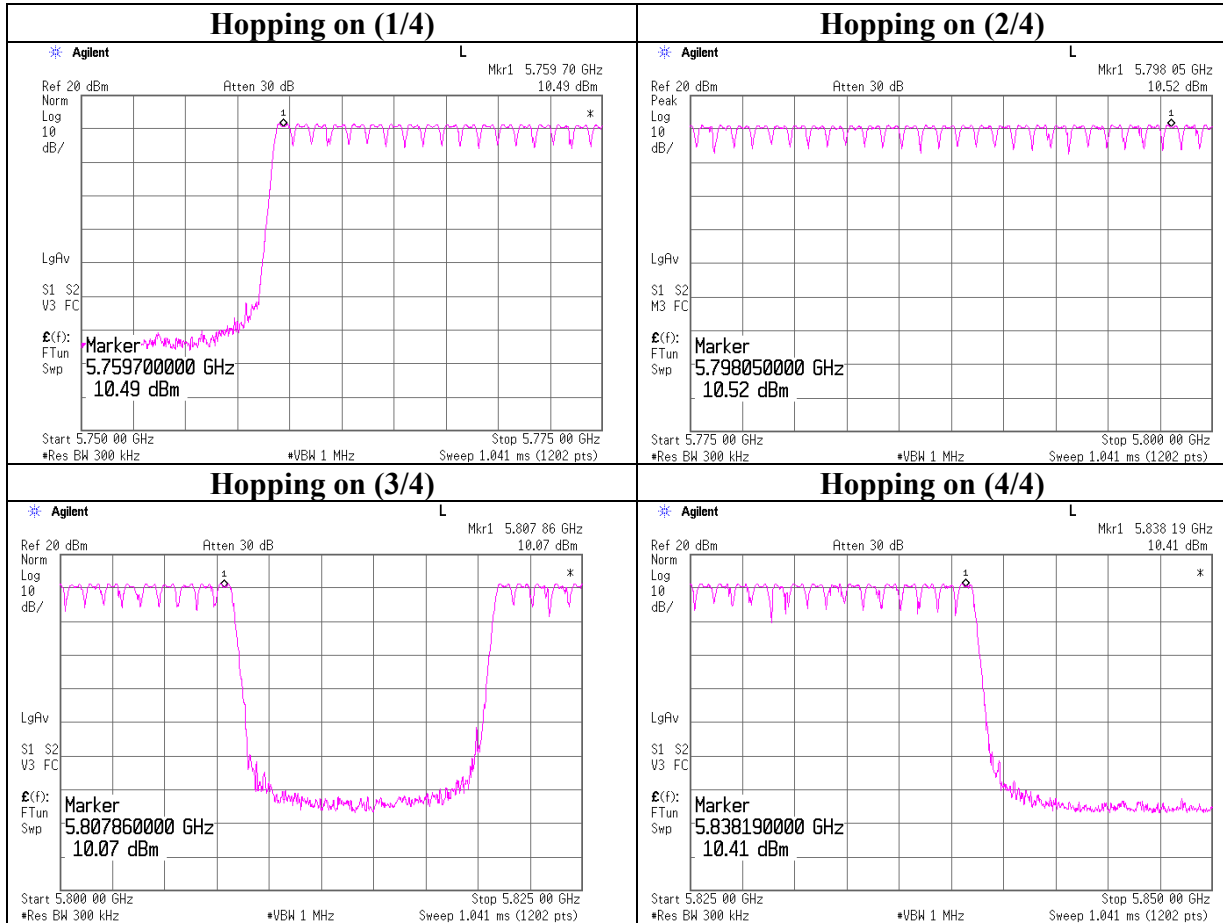

### Dwell time

UL Apex Co., Ltd.  
Head Office EMC Lab. No.3 Shielded Room

COMPANY	: Panasonic Communications	REGULATION	: FCC Part15 Subpart C 15.247(a)(1)(ii)
EQUIPMENT	: Cordless Telephone (Baset)	TEST DISTANCE	: -
MODEL	: KX-TG5771	DATE	: 11/17/2005
S/ N	: 2	TEMPERATURE	: 24deg.C
POWER	: AC 120 V / 60Hz	HUMIDITY	: 29%
MODE	: Tx(Hopping on)	ENGINEER	: Makoto Kosaka

Mode	Number of transmission in a 30sec	Length of transmission time [msec]	Result [msec]	Limit [msec]
Tx Hopping on	58.2 times / 30 sec. x 30 = 58.2 times	0.997	58	400

\*58.2 is the avarege data of 5 tests.

### Dwell time

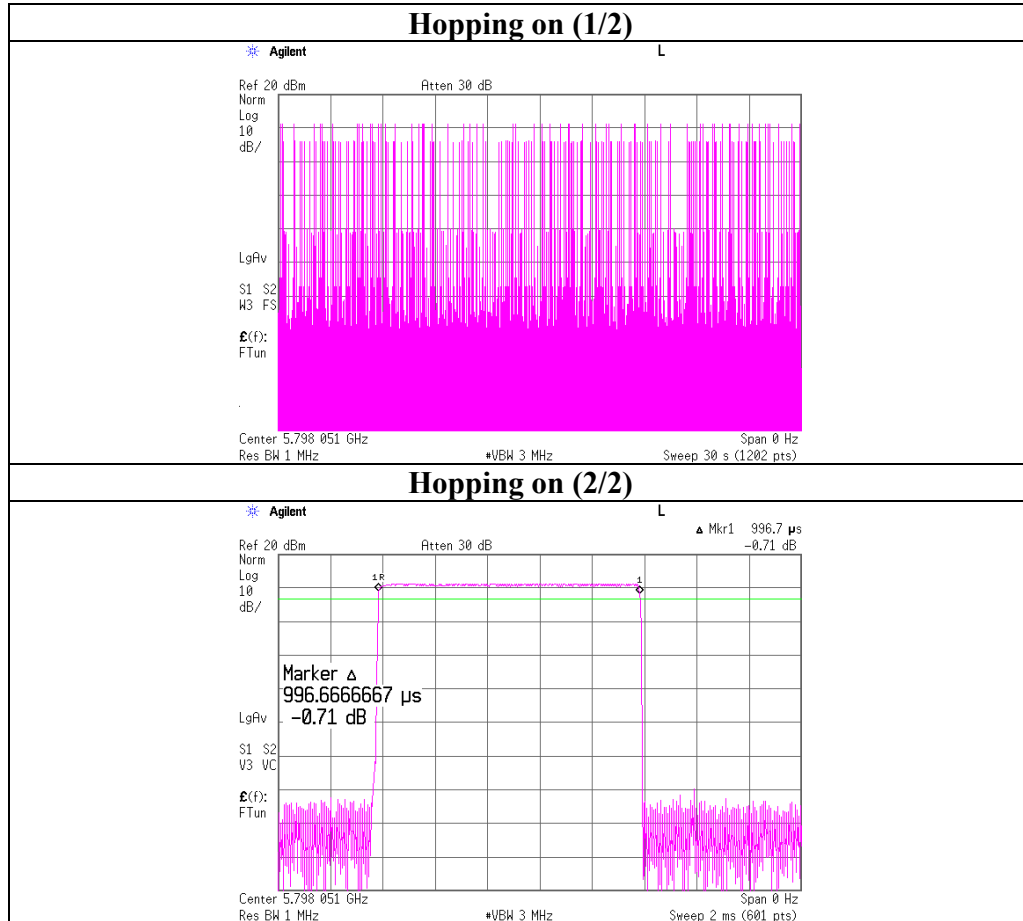

### Maximum Peak Output Power

UL Apex Co., Ltd.  
Head Office EMC Lab. No.3 Shielded Room

COMPANY : Panasonic Communications  
EQUIPMENT : Cordless Telephone (Baset)      REGULATION : FCC Part15 Subpart C 15.247(b)(1)  
MODEL : KX-TG5771      TEST DISTANCE : -  
S/N : 2      DATE : 11/17/2005  
POWER : AC 120 V / 60Hz      TEMPERATURE : 24deg.C  
MODE : Tx(Hopping off)      HUMIDITY : 29%  
ENGINEER : Makoto Kosaka

#### Left-antenna

Ch	Freq. [MHz]	S/A Reading [dBm]	Cable Loss [dB]	Atten. [dB]	Result [dBm]	Limit [dBm]	Margin [dB]
Low	5759.7	11.32	0.10	9.77	21.19	30.00	8.81
Mid	5798.1	11.06	0.10	9.78	20.94	30.00	9.06
High	5838.2	11.04	0.10	9.79	20.93	30.00	9.07

#### Right-antenna

Ch	Freq. [MHz]	S/A Reading [dBm]	Cable Loss [dB]	Atten. [dB]	Result [dBm]	Limit [dBm]	Margin [dB]
Low	5759.7	10.79	0.10	9.77	20.66	30.00	9.34
Mid	5798.1	10.56	0.10	9.78	20.44	30.00	9.56
High	5838.2	10.56	0.10	9.79	20.45	30.00	9.55

Sample Calculation:

Result = Reading + Cable Loss (supplied by customer)+ Attenuator

\* In the above table, factor 0.0dB represents no use of Atten. and/or Filter.

---

**UL Apex Co., Ltd.**

**Head Office EMC Lab.**

4383-326 Asama-cho, Ise-shi, Mie-ken 516-0021 JAPAN

Telephone : +81 596 24 8116

Facsimile : +81 596 24 8124

MF060b(01.06.05)

**Maximum Peak Output Power**  
**Left-antenna**

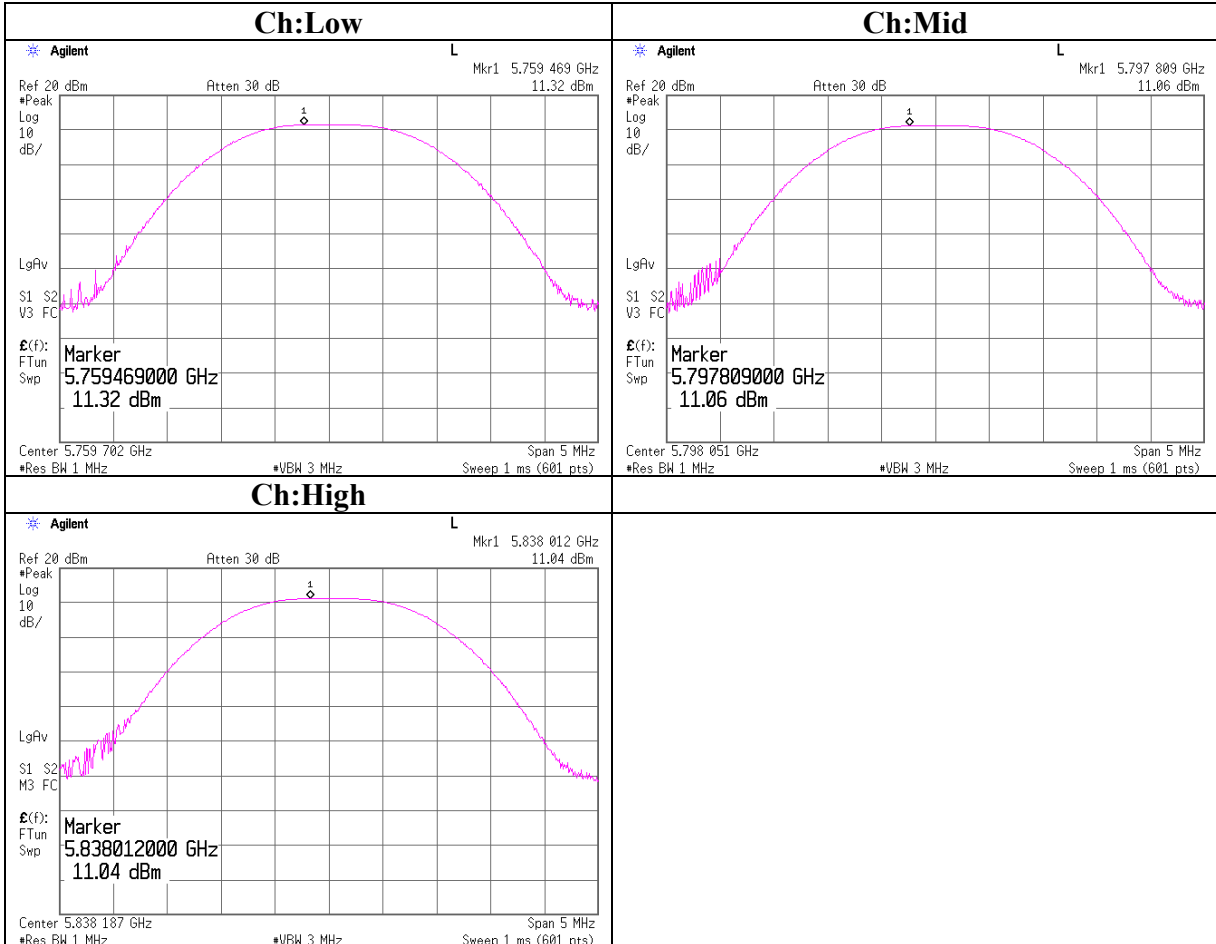

**Maximum Peak Output Power**  
**Right-antenna**

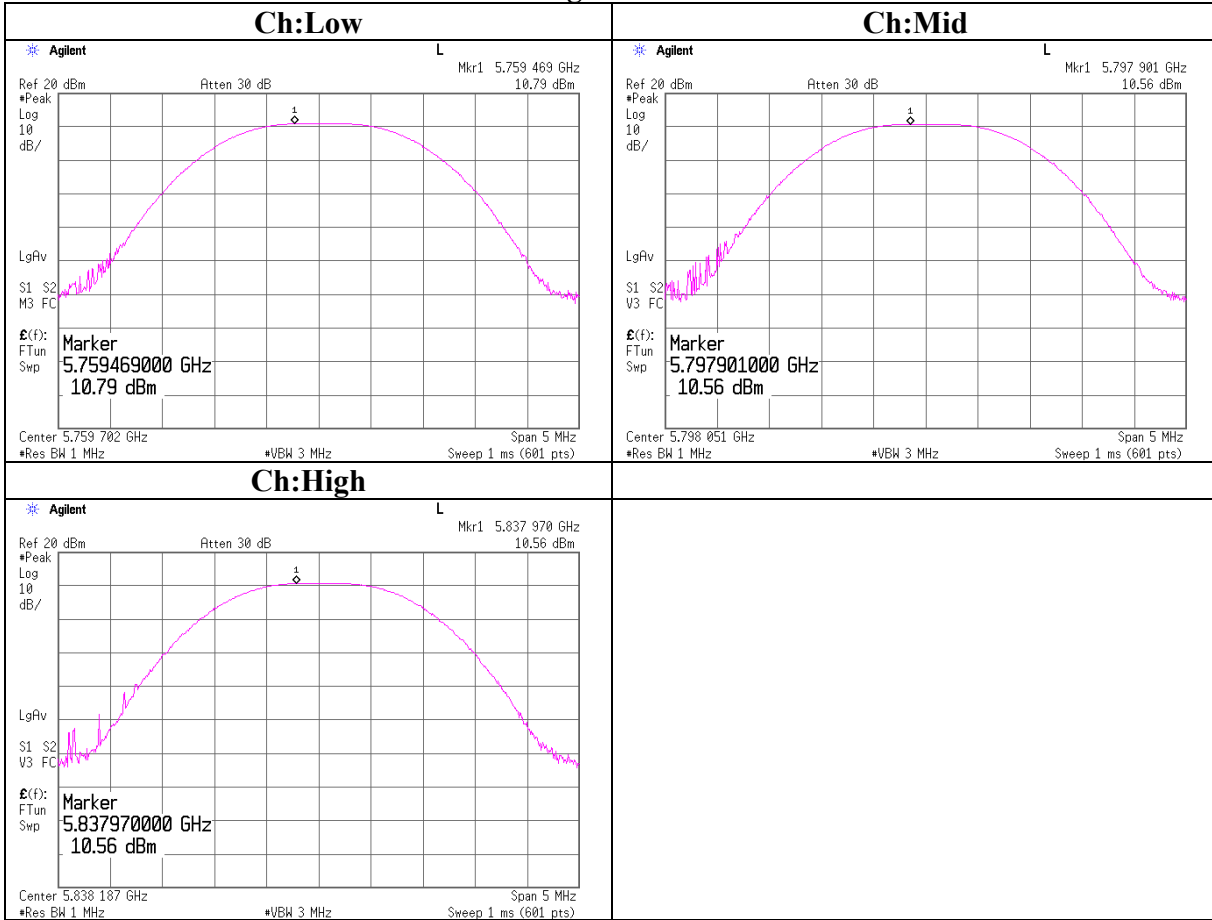

**Radiated Spurious Emission(30MHz-1GHz)**  
**(Tx Low)**

\* The result is rounded off to the second decimal place. Therefore, there may be 0.1 difference for the result.

**DATA OF RADIATED EMISSION TEST**

UL Apex Co., Ltd. Head Office EMC Lab. No. 2 Semi Anechoic Chamber  
 Date : 2005/11/13 10:19:52

Applicant : Panasonic Communications Co.,Ltd. Report No. : 26DE0101-HO  
 Kind of EUT : Base set Power : AC 120V / 60Hz  
 Model No. : KX-TG5771 Temp./Humi. : 20deg. C. / 50%  
 Serial No. : 1 Operator : Norihisa Hashimoto

Mode / Remarks : Tx5759.70240MHz / EUT-axis:Hor Y-axis, Ver Z-axis (Max-axis)

LIMIT : FCC15C § 15.247(d) 3m, below 1GHz:QP, above 1GHz:AV  
 FCC15C § 15.247(d) 3m, below1GHz:QP, above1GHz:AV / RSS-Gen / RSS-210

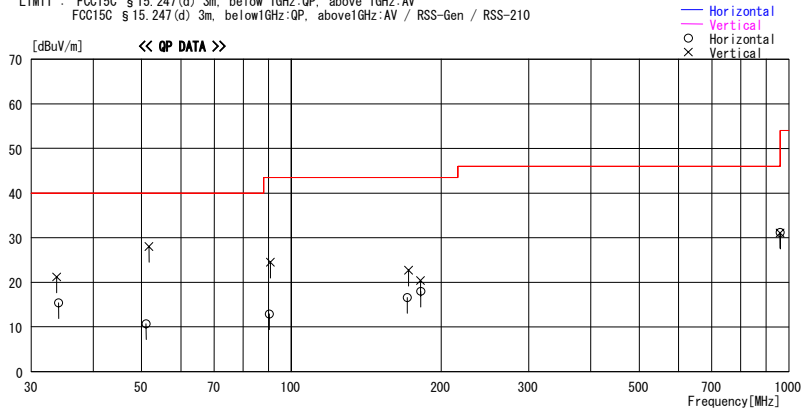

Frequency [MHz]	Reading [dBuV]	DET	Antenna		Level [dBuV/m]	Angle [Deg.]	Height [cm]	Polar.	Limit [dBuV/m]	Margin [dB]
			Factor [dB/m]	Loss& Gain [dB]						
33.758	27.4	QP	16.6	-22.8	21.2	276	385	Vert.	40.0	18.8
34.050	21.7	QP	16.5	-22.8	15.4	298	300	Hori.	40.0	24.6
51.065	23.3	QP	9.9	-22.5	10.7	276	385	Hori.	40.0	29.3
51.769	40.9	QP	9.7	-22.6	28.0	290	100	Vert.	40.0	12.0
90.736	38.6	QP	8.1	-22.2	24.5	280	100	Vert.	43.5	19.0
90.320	27.1	QP	8.0	-22.2	12.9	276	385	Hori.	43.5	30.6
170.940	21.9	QP	15.6	-20.9	16.6	116	300	Hori.	43.5	26.9
172.000	28.0	QP	15.7	-21.0	22.7	276	100	Vert.	43.5	20.8
181.740	25.4	QP	16.1	-21.1	20.4	277	100	Vert.	43.5	23.1
182.010	23.0	QP	16.1	-21.1	18.0	265	230	Hori.	43.5	25.5
959.847	25.9	QP	22.7	-17.4	31.2	4	114	Hori.	46.0	14.8
960.812	25.7	QP	22.7	-17.4	31.0	122	163	Vert.	54.0	23.0

CHART WITH FACTOR ANT TYPE : -30MHz LOOP, 30-300MHz BICONICAL, 300MHz-1000MHz LOGPERIODIC, 1000MHz- HORN  
 CALCULATION: RESULT = READING + ANT FACTOR + LOSS (CABLE+ATTEN.) - GAIN (AMP)

**Radiated Spurious Emission(30MHz-1GHz)**  
**(Tx Mid)**

\* The result is rounded off to the second decimal place. Therefore, there may be 0.1 difference for the result.

**DATA OF RADIATED EMISSION TEST**

UL Apex Co., Ltd. Head Office EMC Lab. No.2 Semi Anechoic Chamber  
 Date : 2005/11/13 11:28:49

Applicant : Panasonic Communications Co.,Ltd. Report No. : 26DE0101-HO  
 Kind of EUT : Baseaset Power : AC 120V / 60Hz  
 Model No. : KX-TG5771 Temp./Humi. : 20deg.C / 50%  
 Serial No. : 1 Operator : Norihisa Hashimoto

Mode / Remarks : Tx5798.05084MHz /EUT-axis:Hor Y-axis, Ver Z-axis (Max-axis)

LIMIT : FCC15C §15.247(d) 3m, below 1GHz:QP, above 1GHz:AV  
 FCC15C §15.247(d) 3m, below1GHz:QP, above1GHz:AV / RSS-Gen / RSS-210

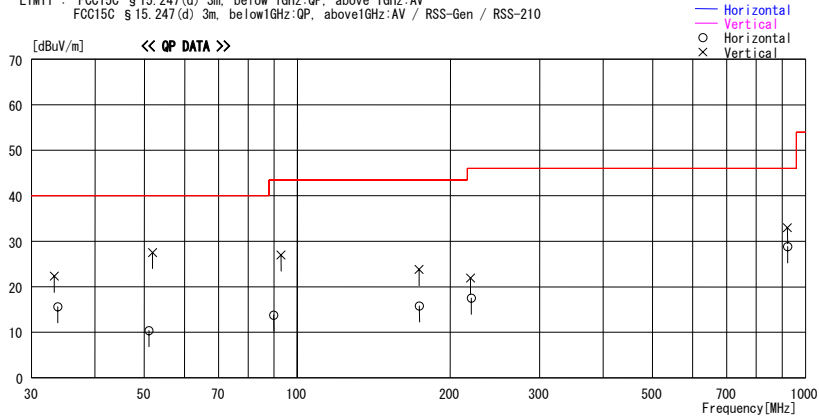

Frequency [MHz]	Reading [dBuV]	DET	Antenna		Level [dBuV/m]	Angle [Deg]	Height [cm]	Polar.	Limit [dBuV/m]	Margin [dB]
			Factor [dB/m]	Loss& Gain [dB]						
33.240	28.3	QP	16.8	-22.8	22.3	262	100	Vert.	40.0	17.7
33.780	21.8	QP	16.6	-22.8	15.6	0	300	Hori.	40.0	24.4
51.920	40.4	QP	9.7	-22.6	27.5	354	100	Vert.	40.0	12.5
51.060	23.0	QP	9.9	-22.5	10.4	304	210	Hori.	40.0	29.6
89.895	28.1	QP	7.9	-22.2	13.8	79	322	Hori.	43.5	29.7
92.910	40.8	QP	8.5	-22.3	27.0	122	100	Vert.	43.5	16.5
173.640	29.0	QP	15.8	-21.0	23.8	261	100	Vert.	43.5	19.7
173.910	21.1	QP	15.8	-21.1	15.8	354	300	Hori.	43.5	27.7
219.271	25.8	QP	16.8	-20.7	21.9	252	100	Vert.	46.0	24.1
220.081	21.4	QP	16.8	-20.7	17.5	311	300	Hori.	46.0	28.5
922.311	24.6	QP	21.5	-17.3	28.8	0	232	Hori.	46.0	17.2
921.611	28.8	QP	21.5	-17.3	33.0	0	232	Vert.	46.0	13.0

CHART: WITH FACTOR ANT TYPE : -30MHz LOOP, 30-300MHz BICONICAL, 300MHz-1000MHz LOGPERIODIC, 1000MHz- HORN  
 CALCULATION: RESULT = READING + ANT FACTOR + LOSS (CABLE+ATTEN.) - GAIN (AMP)

**Radiated Spurious Emission(30MHz-1GHz)**  
**(Tx High)**

\* The result is rounded off to the second decimal place. Therefore, there may be 0.1 difference for the result.

**DATA OF RADIATED EMISSION TEST**

UL Apex Co., Ltd. Head Office EMC Lab. No. 2 Semi Anechoic Chamber  
 Date : 2005/11/13 13:36:42

Applicant : Panasonic Communications Co.,Ltd. Report No. : 26DE0101-HO  
 Kind of EUT : Baseaset Power : AC 120V / 60Hz  
 Model No. : KX-TG5771 Temp./Humi. : 20deg. C. / 50%  
 Serial No. : 1 Operator : Norihisa Hashimoto

Mode / Remarks : Tx5838.1867MHz /EUT-axis:Hor Y-axis, Ver Z-axis (Max-axis)

LIMIT : FCC15C §15.247(d) 3m, below 1GHz:QP, above 1GHz:AV  
 FCC15C §15.247(d) 3m, below1GHz:QP, above1GHz:AV / RSS-Gen / RSS-210

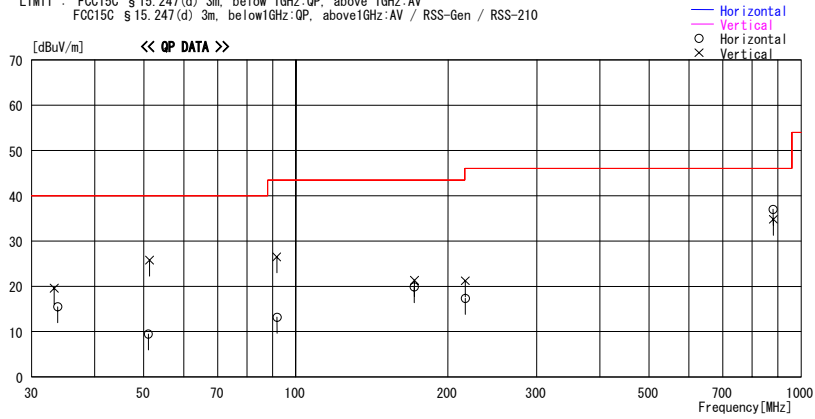

Frequency [MHz]	Reading [dBuV]	DET	Antenna	Loss	Level [dBuV/m]	Angle [Deg]	Height [cm]	Polar.	Limit [dBuV/m]	Margin [dB]
			Factor [dB/m]	Gain [dB]						
33.240	25.6	QP	16.8	-22.8	19.6	20	100	Vert.	40.0	20.4
33.780	21.7	QP	16.6	-22.8	15.5	209	313	Hor.	40.0	24.5
51.060	22.1	QP	9.9	-22.5	9.5	157	287	Hor.	40.0	30.5
51.330	38.6	QP	9.8	-22.6	25.8	170	100	Vert.	40.0	14.2
91.666	40.5	QP	8.2	-22.2	26.5	358	112	Vert.	43.5	17.0
91.830	27.1	QP	8.3	-22.2	13.2	78	269	Hor.	43.5	30.3
171.480	25.2	QP	15.7	-21.0	19.9	230	190	Hor.	43.5	23.6
171.750	26.6	QP	15.7	-21.0	21.3	213	107	Vert.	43.5	22.2
216.571	21.2	QP	16.8	-20.7	17.3	65	296	Hor.	46.0	28.7
216.571	25.1	QP	16.8	-20.7	21.2	204	100	Vert.	46.0	24.8
881.018	33.9	QP	20.9	-17.8	37.0	147	104	Hor.	46.0	9.0
881.710	31.6	QP	20.9	-17.7	34.8	194	128	Vert.	46.0	11.2

CHART WITH FACTOR ANT TYPE : -30MHz LOOP, 30-300MHz BICONICAL, 300MHz-1000MHz LOGPERIODIC, 1000MHz- HORN  
 CALCULATION RESULT = READING + ANT FACTOR + LOSS (CABLE+ATTEN.) - GAIN (AMP)

**Radiated Spurious Emission(1GHz-40GHz)**  
**(Tx Low)**

UL Apex Co., Ltd.  
Head Office EMC Lab. No.2 Semi Anechoic Chamber

Company : Panasonic Communications Co.,Ltd. REPORT NO : 26DE0101-HO  
Equipment : Cordless Telephone (Baseset) REGULATION : FCC Part15 Subpart C 15.247(d)  
Model : KX-TG5771 TEST DISTANCE : 3m/1m/0.5m  
Sample No. : 1 DATE : 11/15/2005, 11/23/2005,  
Power : AC120V / 60Hz TEMPERATURE : 25deg.C, 20deg.C,  
Mode : Tx 5759.70240MHz HUMIDITY : 38%, 34%,  
Remarks : Hor : ANT-0deg / Ver : ANT-90deg ENGINEER : Takumi Shimada

**PK DETECT (RBW: 1MHz, VBW: 1MHz)**

No.	FREQ [MHz]	S/A READING		ANT Factor [dB/m]	AMP GAIN [dB]	CABLE LOSS [dB]	Band-Pass Filter [dB]	RESULT		Limit PK [dBuV/m]	MARGIN	
		HOR [dBuV]	VER [dBuV]					HOR	VER		HOR	VER
<b>Test distance 3meters RESULT=Reading + ANT Factor - Amp Gain + Cable Loss + Filter Loss</b>												
1	2400.1	54.9	53.7	30.5	36.4	4.6	0.0	53.6	52.4	74.0	20.4	21.6
2	4800.5	48.7	49.8	35.1	36.0	6.6	0.0	54.4	55.5	74.0	19.6	18.5
3	5359.5	55.4	58.4	35.9	35.8	7.0	0.0	62.5	65.5	74.0	11.5	8.5
4	5725.0	49.0	49.7	36.4	35.8	7.2	0.0	56.8	57.5	74.0	17.2	16.5
5	6159.4	51.2	51.8	36.8	35.8	7.5	0.0	59.7	60.3	74.0	14.3	13.7
<b>Test distance 1meters RESULT=Reading + ANT Factor - Amp Gain + Cable Loss + Filter Loss - Dfac</b>												
6	11519.1	55.2	54.6	39.0	35.8	11.5	0.2	60.6	60.0	74.0	13.4	14.0
7*	17278.4	51.3	48.1	44.8	35.0	14.3	4.7	70.6	67.4	-	-	-
8	23038.5	44.6	43.3	40.2	34.9	16.5	0.0	56.9	55.6	74.0	17.1	18.4
<b>Test distance 0.5meters RESULT=Reading + ANT Factor - Amp Gain + Cable Loss + Filter Loss - Dfac</b>												
9	28798.5	33.8	34.5	41.3	24.3	11.3	0.0	46.5	47.2	74.0	27.5	26.8
10	34558.2	38.9	39.5	42.2	24.6	12.3	0.0	53.2	53.8	74.0	20.8	20.2

**AV DETECT (RBW: 1MHz, VBW: 10Hz)**

No.	FREQ [MHz]	S/A READING		ANT Factor [dB/m]	AMP GAIN [dB]	CABLE LOSS [dB]	Band-Pass Filter [dB]	RESULT		Limit AV [dBuV/m]	MARGIN	
		HOR [dBuV]	VER [dBuV]					HOR	VER		HOR	VER
<b>Test distance 3meters RESULT=Reading + ANT Factor - Amp Gain + Cable Loss + Filter Loss</b>												
1	2400.1	38.7	37.7	30.5	36.4	4.6	0.0	37.4	36.4	54.0	16.6	17.6
2	4800.5	34.0	35.4	35.1	36.0	6.6	0.0	39.7	41.1	54.0	14.3	12.9
3	5359.5	33.1	35.1	35.9	35.8	7.0	0.0	40.2	42.2	54.0	13.8	11.8
4	5725.0	30.2	32.0	36.4	35.8	7.2	0.0	38.0	39.8	54.0	16.0	14.2
5	6159.4	31.5	32.6	36.8	35.8	7.5	0.0	40.0	41.1	54.0	14.0	12.9
<b>Test distance 1meters RESULT=Reading + ANT Factor - Amp Gain + Cable Loss + Filter Loss - Dfac</b>												
6	11519.1	35.8	33.8	39.0	35.8	11.5	0.2	41.2	39.2	54.0	12.8	14.8
7*	17278.4	33.7	33.9	44.8	35.0	14.3	4.7	53.0	53.2	-	-	-
8	23038.5	29.7	29.6	40.2	34.9	16.5	0.0	42.0	41.9	54.0	12.0	12.1
<b>Test distance 0.5meters RESULT=Reading + ANT Factor - Amp Gain + Cable Loss + Filter Loss - Dfac</b>												
9	28798.5	21.0	21.5	41.3	24.3	11.3	0.0	33.7	34.2	54.0	20.3	19.8
10	34558.2	26.8	27.4	42.2	24.6	12.3	0.0	41.1	41.7	54.0	12.9	12.3

\* Reference data

**20dBc(Fundamental 5759.7MHz) (RBW: 100kHz, VBW: 300kHz)**

No.	FREQ [MHz]	S/A READING		ANT Factor [dB/m]	AMP GAIN [dB]	CABLE LOSS [dB]	Band-Pass Filter or ATT [dB]	RESULT		Limit 20dBc [dBuV/m]	MARGIN	
		HOR [dBuV]	VER [dBuV]					HOR	VER		HOR	VER
<b>Test distance 3meters RESULT=Reading + ANT Factor - Amp Gain + Cable Loss + Filter Loss</b>												
0	5759.7	105.0	102.2	36.4	35.8	7.2	10.0	122.8	120.0	-	-	-
7	17278.4	49.0	41.2	44.8	35.0	14.3	4.7	68.3	60.5	Funda-20dB	34.5	39.5

Test Distance 1.0m : Distance Factor(Dfac) = 20log(3/1.0) = 9.5dB

Test Distance 0.5m : Distance Factor(Dfac) = 20log(3/0.5) = 15.6dB

\*Except for the above table : All other spurious emissions were less than 20dB for the limit.

\*In the frequency over the fifth harmonic, the noise from the EUT was not seen. The data above is its base noise.

\*The result is rounded off to the second decimal place. Therefore, there may be 0.1 difference for the result.

\*Hi-Pass Filter was not used for factor 0.0dB of the above table.

**UL Apex Co., Ltd.**

**Head Office EMC Lab.**

4383-326 Asama-cho, Ise-shi, Mie-ken 516-0021 JAPAN

Telephone : +81 596 24 8116

Facsimile : +81 596 24 8124

MF060b(01.06.05)

**Radiated Spurious Emission(1GHz-40GHz)**  
**(Tx Mid)**

UL Apex Co., Ltd.  
Head Office EMC Lab. No.2 Semi Anechoic Chamber

Company	: Panasonic Communications Co.,Ltd.	REPORT NO	: 26DE0101-HO
Equipment	: Cordless Telephone (Basetset)	REGULATION	: FCC Part15 Subpart C 15.247(d)
Model	: KX-TG5771	TEST DISTANCE	: 3m/1m/0.5m
Sample No.	: 1	DATE	: 11/15/2005 11/23/2005.
Power	: AC120V / 60Hz	TEMPERATURE	: 24deg.C 20deg.C.
Mode	: Tx 5798.05084MHz	HUMIDITY	: 42% 34%,
Remarks	: Hor : ANT-0deg / Ver : ANT-90deg	ENGINEER	: Takumi Shimada

**PK DETECT (RBW: 1MHz, VBW: 1MHz)**

No.	FREQ [MHz]	S/A READING		ANT Factor [dB/m]	AMP GAIN [dB]	CABLE LOSS [dB]	Band-Pass Filter [dB]	RESULT		Limit PK [dBuV/m]	MARGIN	
		HOR	VER					HOR	VER		HOR	VER
Test distance 3meters RESULT=Reading + ANT Factor - Amp Gain + Cable Loss + Filter Loss												
1	2438.3	56.9	52.4	30.5	36.4	4.5	0.0	55.5	51.0	74.0	18.5	23.0
2	4876.5	52.7	52.3	35.6	36.0	6.6	0.0	58.9	58.5	74.0	15.1	15.5
3	5201.9	61.1	58.1	36.1	35.9	6.9	0.0	68.2	65.2	74.0	5.8	8.8
4	5529.0	53.2	51.9	35.9	35.9	7.0	0.0	60.2	58.9	74.0	13.8	15.1
5	6066.9	49.8	50.5	36.9	35.8	7.4	0.0	58.3	59.0	74.0	15.7	15.0
6	6393.1	52.6	50.0	36.6	35.8	7.7	0.0	61.1	58.5	74.0	12.9	15.5
Test distance 1meters RESULT=Reading + ANT Factor - Amp Gain + Cable Loss + Filter Loss - Dfac												
7	11596.5	53.3	53.3	39.4	35.9	11.7	0.2	59.2	59.2	74.0	14.8	14.8
8*	17394.6	49.0	46.2	44.6	35.1	14.4	5.5	68.9	66.1	-	-	-
9	23192.1	43.6	44.9	40.4	34.8	16.7	0.0	56.4	57.7	74.0	17.6	16.3
Test distance 0.5meters RESULT=Reading + ANT Factor - Amp Gain + Cable Loss + Filter Loss - Dfac												
10	28990.3	33.9	34.1	41.3	24.4	11.4	0.0	46.6	46.8	74.0	27.4	27.2
11	34788.3	41.9	40.9	42.1	24.5	12.4	0.0	56.3	55.3	74.0	17.7	18.7

**AV DETECT (RBW: 1MHz, VBW: 10Hz)**

No.	FREQ [MHz]	S/A READING		ANT Factor [dB/m]	AMP GAIN [dB]	CABLE LOSS [dB]	Band-Pass Filter [dB]	RESULT		Limit AV [dBuV/m]	MARGIN	
		HOR	VER					HOR	VER		HOR	VER
Test distance 3meters RESULT=Reading + ANT Factor - Amp Gain + Cable Loss + Filter Loss												
1	2438.3	42.4	37.0	30.5	36.4	4.5	0.0	41.0	35.6	54.0	13.0	18.4
2	4876.5	37.3	36.0	35.6	36.0	6.6	0.0	43.5	42.2	54.0	10.5	11.8
3	5201.9	37.5	36.9	36.1	35.9	6.9	0.0	44.6	44.0	54.0	9.4	10.0
4	5529.0	34.8	33.6	35.9	35.9	7.0	0.0	41.8	40.6	54.0	12.2	13.4
5	6066.9	33.6	33.3	36.9	35.8	7.4	0.0	42.1	41.8	54.0	11.9	12.2
6	6393.1	34.4	33.6	36.6	35.8	7.7	0.0	42.9	42.1	54.0	11.1	11.9
Test distance 1meters RESULT=Reading + ANT Factor - Amp Gain + Cable Loss + Filter Loss - Dfac												
7	11596.5	33.6	35.4	39.4	35.9	11.7	0.2	39.5	41.3	54.0	14.5	12.7
8*	17394.6	33.1	32.6	44.6	35.1	14.4	5.5	53.0	52.5	-	-	-
9	23192.1	29.3	32.0	40.4	34.8	16.7	0.0	42.1	44.8	54.0	11.9	9.2
Test distance 0.5meters RESULT=Reading + ANT Factor - Amp Gain + Cable Loss + Filter Loss - Dfac												
10	28990.3	20.8	20.9	41.3	24.4	11.4	0.0	33.5	33.6	54.0	20.5	20.4
11	34788.3	27.4	27.6	42.1	24.5	12.4	0.0	41.8	42.0	54.0	12.2	12.0

\* Reference data

**20dBc(Fundamental 5798.1MHz) (RBW: 100kHz, VBW: 300kHz)**

No.	FREQ [MHz]	S/A READING		ANT Factor [dB/m]	AMP GAIN [dB]	CABLE LOSS [dB]	Band-Pass Filter or ATT [dB]	RESULT		Limit 20dBc [dBuV/m]	MARGIN	
		HOR	VER					HOR	VER		HOR	VER
Test distance 3meters RESULT=Reading + ANT Factor - Amp Gain + Cable Loss + Filter Loss												
0	5798.1	104.2	102.5	36.5	35.8	7.3	10.0	122.2	120.5	-	-	-
8	17393.5	46.8	40.4	44.6	35.1	14.4	5.5	66.7	60.3	Funda-20dB	35.5	40.2

Test Distance 1.0m : Distance Factor(Dfac) = 20log(3/1.0) = 9.5dB

Test Distance 0.5m : Distance Factor(Dfac) = 20log(3/0.5) = 15.6dB

\*Except for the above table : All other spurious emissions were less than 20dB for the limit.

\*In the frequency over the fifth harmonic, the noise from the EUT was not seen. The data above is its base noise.

\*The result is rounded off to the second decimal place. Therefore, there may be 0.1 difference for the result.

\*Hi-Pass Filter was not used for factor 0.0dB of the above table.

**Radiated Spurious Emission(1GHz-40GHz)**  
**(Tx High)**

UL Apex Co., Ltd.  
Head Office EMC Lab. No.2 Semi Anechoic Chamber

Company	: Panasonic Communications Co.,Ltd.	REPORT NO	: 26DE0101-HO
Equipment	: Cordless Telephone (Baset)	REGULATION	: FCC Part15 Subpart C 15.247(d)
Model	: KX-TG5771	TEST DISTANCE	: 3m/1m/0.5m
Sample No.	: 1	DATE	: 11/15/2005 11/23/2005,
Power	: AC120V / 60Hz	TEMPERATURE	: 24deg.C 20deg.C,
Mode	: Tx 5838.18697MHz	HUMIDITY	: 42% 34%,
Remarks	: Hor : ANT-0deg / Ver : ANT-90deg	ENGINEER	: Takumi Shimada

**PK DETECT** (RBW: 1MHz, VBW: 1MHz)

No.	FREQ [MHz]	S/A READING		ANT Factor [dB/m]	AMP GAIN [dB]	CABLE LOSS [dB]	Band-Pass Filter [dB]	RESULT		Limit PK [dBuV/m]	MARGIN	
		HOR [dBuV]	VER [dBuV]					HOR [dBuV/m]	VER [dBuV/m]		HOR [dB]	VER [dB]
<b>Test distance 3meters RESULT=Reading + ANT Factor - Amp Gain + Cable Loss + Filter Loss</b>												
1	2478.5	51.0	50.9	30.5	36.4	4.6	0.0	49.7	49.6	74.0	24.3	24.4
2	4956.6	56.0	51.3	36.1	35.9	6.7	0.0	62.9	58.2	74.0	11.1	15.8
3	5121.7	54.9	54.5	36.2	35.9	6.8	0.0	62.0	61.6	74.0	12.0	12.4
4	5852.0	59.9	60.1	36.7	35.8	7.3	0.0	68.1	68.3	74.0	5.9	5.7
5	6003.8	55.0	53.6	37.0	35.8	7.3	0.0	63.5	62.1	74.0	10.5	11.9
6	6555.1	49.3	47.2	36.6	35.8	7.7	0.0	57.8	55.7	74.0	16.2	18.3
<b>Test distance 1meters RESULT=Reading + ANT Factor - Amp Gain + Cable Loss + Filter Loss - Dfac</b>												
7	11676.8	50.1	52.8	39.9	35.9	11.7	0.3	56.6	59.3	74.0	17.4	14.7
8*	17514.2	41.4	45.6	44.4	35.1	14.5	6.2	61.9	66.1	-	-	-
9	23352.9	42.6	46.6	40.5	34.7	16.9	0.0	55.8	59.8	74.0	18.2	14.2
<b>Test distance 0.5meters RESULT=Reading + ANT Factor - Amp Gain + Cable Loss + Filter Loss - Dfac</b>												
10	29190.9	33.0	34.1	41.3	24.4	11.4	0.0	45.7	46.8	74.0	28.3	27.2
11	35029.1	41.1	42.2	42.1	24.4	12.5	0.0	55.7	56.8	74.0	18.3	17.2

**AV DETECT** (RBW: 1MHz, VBW: 10Hz)

No.	FREQ [MHz]	S/A READING		ANT Factor [dB/m]	AMP GAIN [dB]	CABLE LOSS [dB]	Band-Pass Filter [dB]	RESULT		Limit AV [dBuV/m]	MARGIN	
		HOR [dBuV]	VER [dBuV]					HOR [dBuV/m]	VER [dBuV/m]		HOR [dB]	VER [dB]
<b>Test distance 3meters RESULT=Reading + ANT Factor - Amp Gain + Cable Loss + Filter Loss</b>												
1	2478.5	38.0	36.4	30.5	36.4	4.6	0.0	36.7	35.1	54.0	17.3	18.9
2	4956.6	38.2	35.3	36.1	35.9	6.7	0.0	45.1	42.2	54.0	8.9	11.8
3	5121.7	37.8	35.8	36.2	35.9	6.8	0.0	44.9	42.9	54.0	9.1	11.1
4	5852.0	37.1	35.6	36.7	35.8	7.3	0.0	45.3	43.8	54.0	8.7	10.2
5	6003.8	36.2	35.3	37.0	35.8	7.3	0.0	44.7	43.8	54.0	9.3	10.2
6	6555.1	35.3	33.1	36.6	35.8	7.7	0.0	43.8	41.6	54.0	10.2	12.4
<b>Test distance 1meters RESULT=Reading + ANT Factor - Amp Gain + Cable Loss + Filter Loss - Dfac</b>												
7	11676.8	32.8	34.0	39.9	35.9	11.7	0.3	39.3	40.5	54.0	14.7	13.5
8*	17514.2	33.0	33.1	44.4	35.1	14.5	6.2	53.5	53.6	-	-	-
9	23352.9	32.5	32.2	40.5	34.7	16.9	0.0	45.7	45.4	54.0	8.3	8.6
<b>Test distance 0.5meters RESULT=Reading + ANT Factor - Amp Gain + Cable Loss + Filter Loss - Dfac</b>												
10	29190.9	33.5	20.7	41.3	24.4	11.4	0.0	46.2	33.4	54.0	7.8	20.6
11	35029.1	28.2	28.2	42.1	24.4	12.5	0.0	42.8	42.8	54.0	11.2	11.2

\* Reference data

**20dBc(Fundamental 5838.2MHz)** (RBW: 100kHz, VBW: 300kHz)

No.	FREQ [MHz]	S/A READING		ANT Factor [dB/m]	AMP GAIN [dB]	CABLE LOSS [dB]	Band-Pass Filter or ATT [dB]	RESULT		Limit 20dBc [dBuV/m]	MARGIN	
		HOR [dBuV]	VER [dBuV]					HOR [dBuV/m]	VER [dBuV/m]		HOR [dB]	VER [dB]
<b>Test distance 3meters RESULT=Reading + ANT Factor - Amp Gain + Cable Loss + Filter Loss</b>												
0	5838.2	106.4	103.4	36.6	35.8	7.3	10.0	124.5	121.5	-	-	-
8	17514.2	48.8	39.0	44.4	35.1	14.5	6.2	69.3	59.5	Funda-20dB	35.2	42.0

Test Distance 1.0m : Distance Factor(Dfac) = 20log(3/1.0) = 9.5dB

Test Distance 0.5m : Distance Factor(Dfac) = 20log(3/0.5) = 15.6dB

\*Except for the above table : All other spurious emissions were less than 20dB for the limit.

\*In the frequency over the fifth harmonic, the noise from the EUT was not seen. The data above is its base noise.

\*The result is rounded off to the second decimal place. Therefore, there may be 0.1 difference for the result.

\*Hi-Pass Filter was not used for factor 0.0dB of the above table.

**Conducted Spurious Emission**  
**Ch:Low**

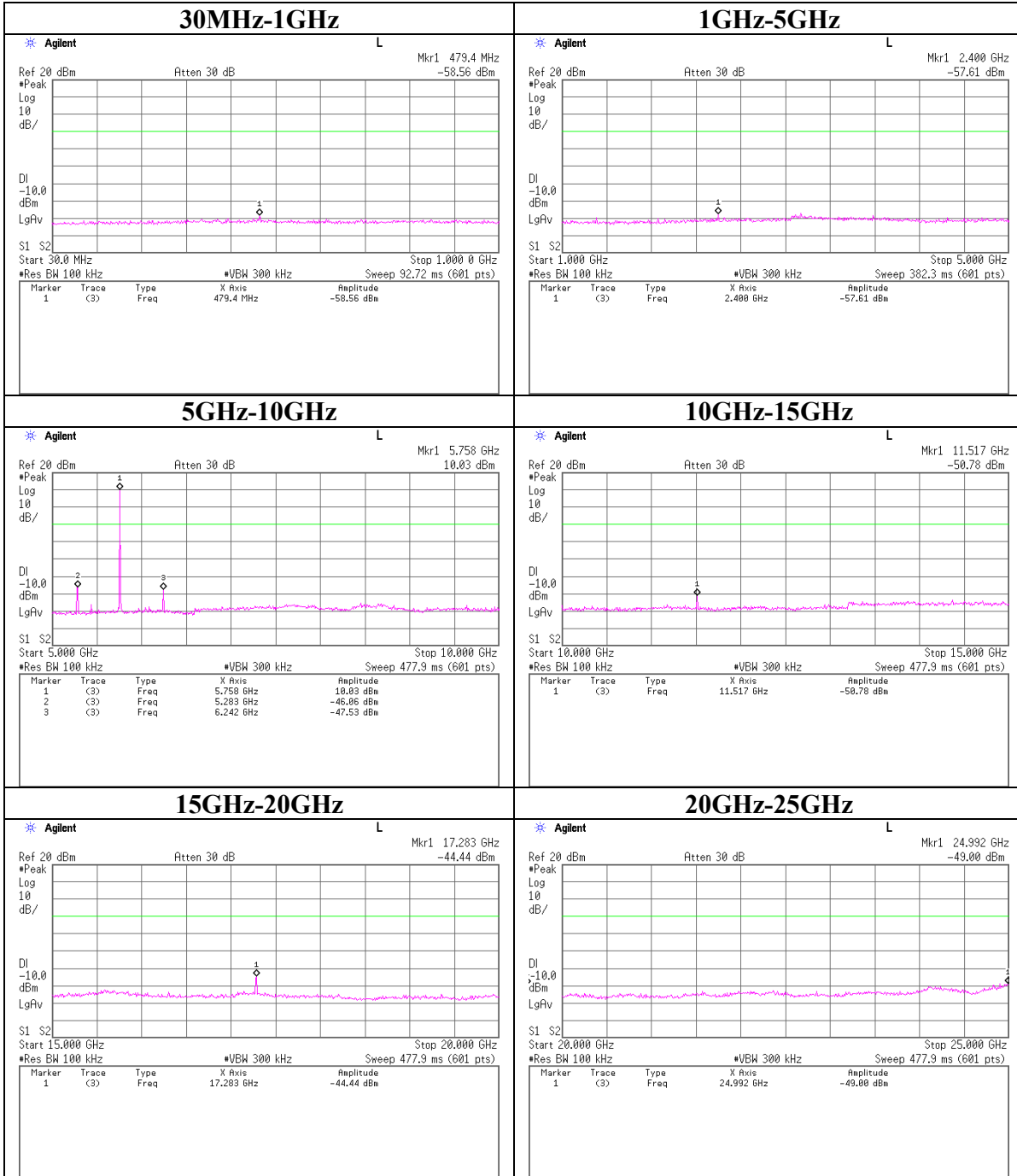

**Conducted Spurious Emission**  
**Ch:Low**

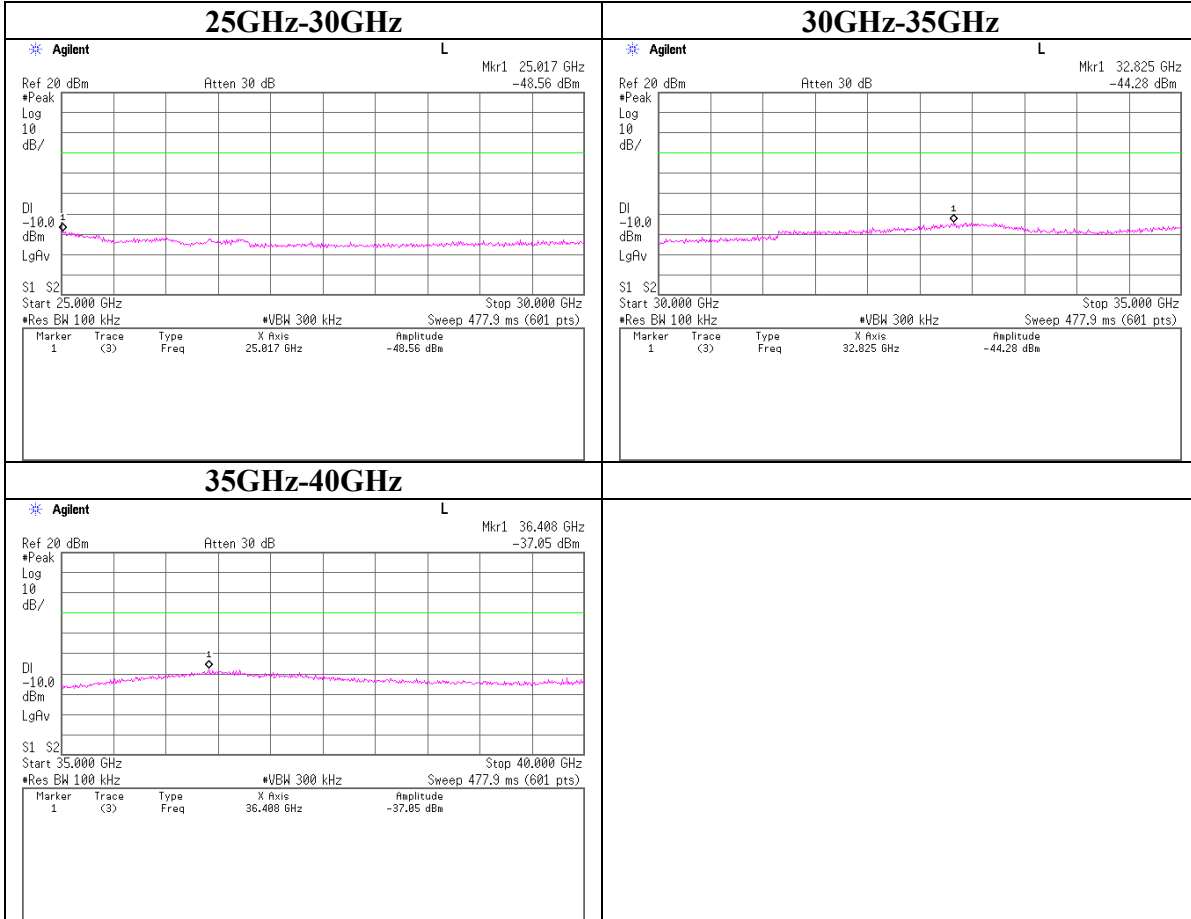

**Conducted Spurious Emission**  
**Ch:Mid**

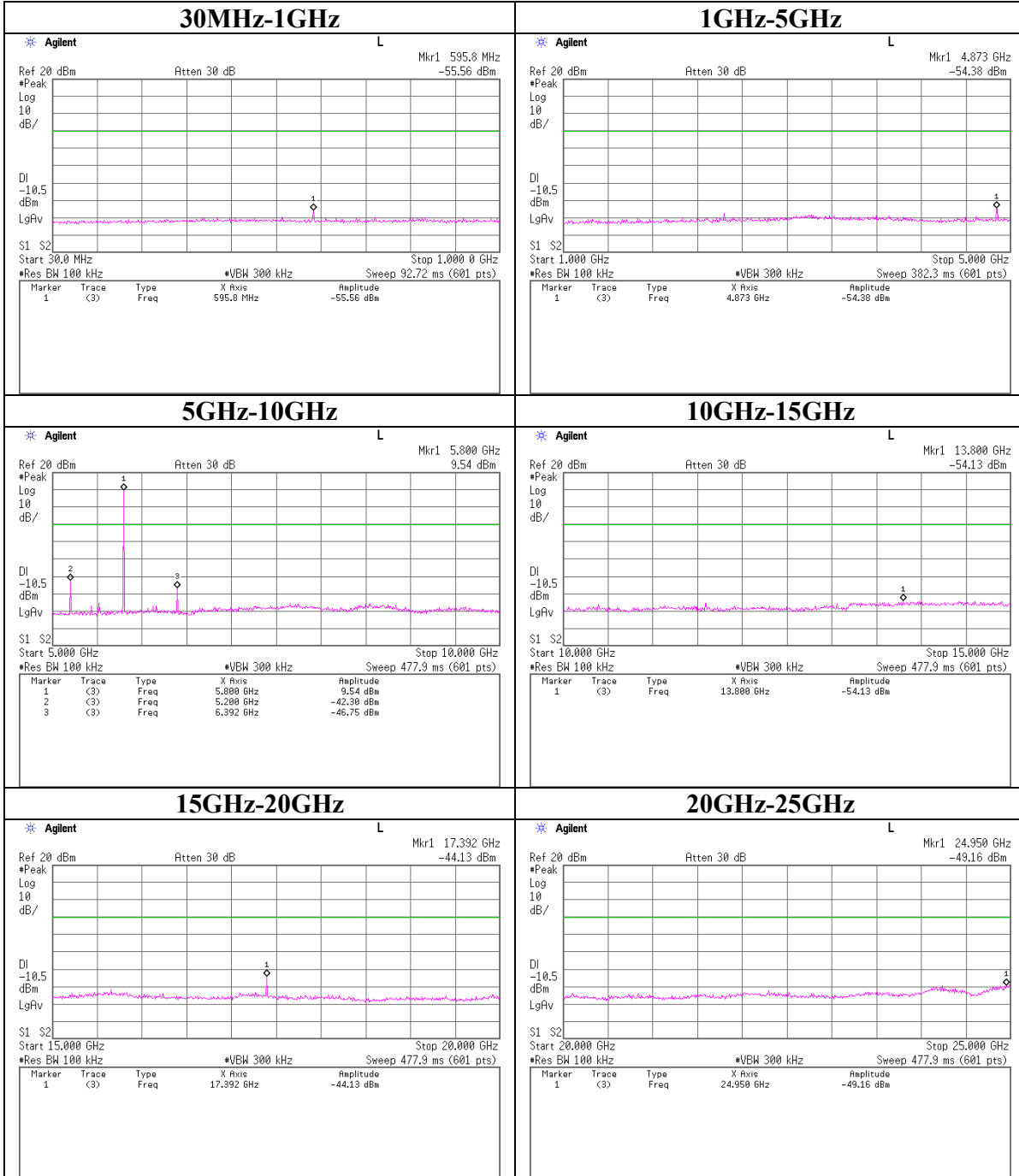

**Conducted Spurious Emission**  
**Ch:Mid**

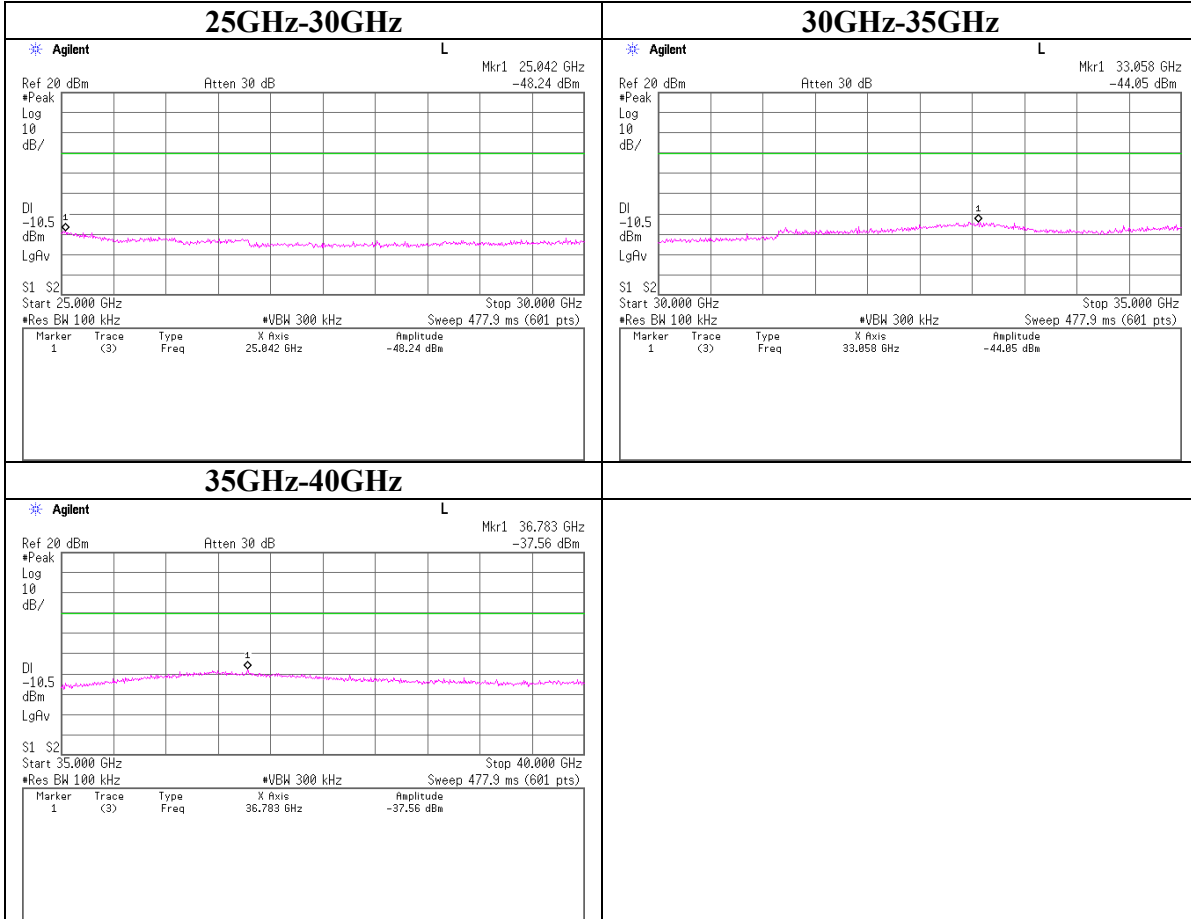

**Conducted Spurious Emission**  
**Ch:High**

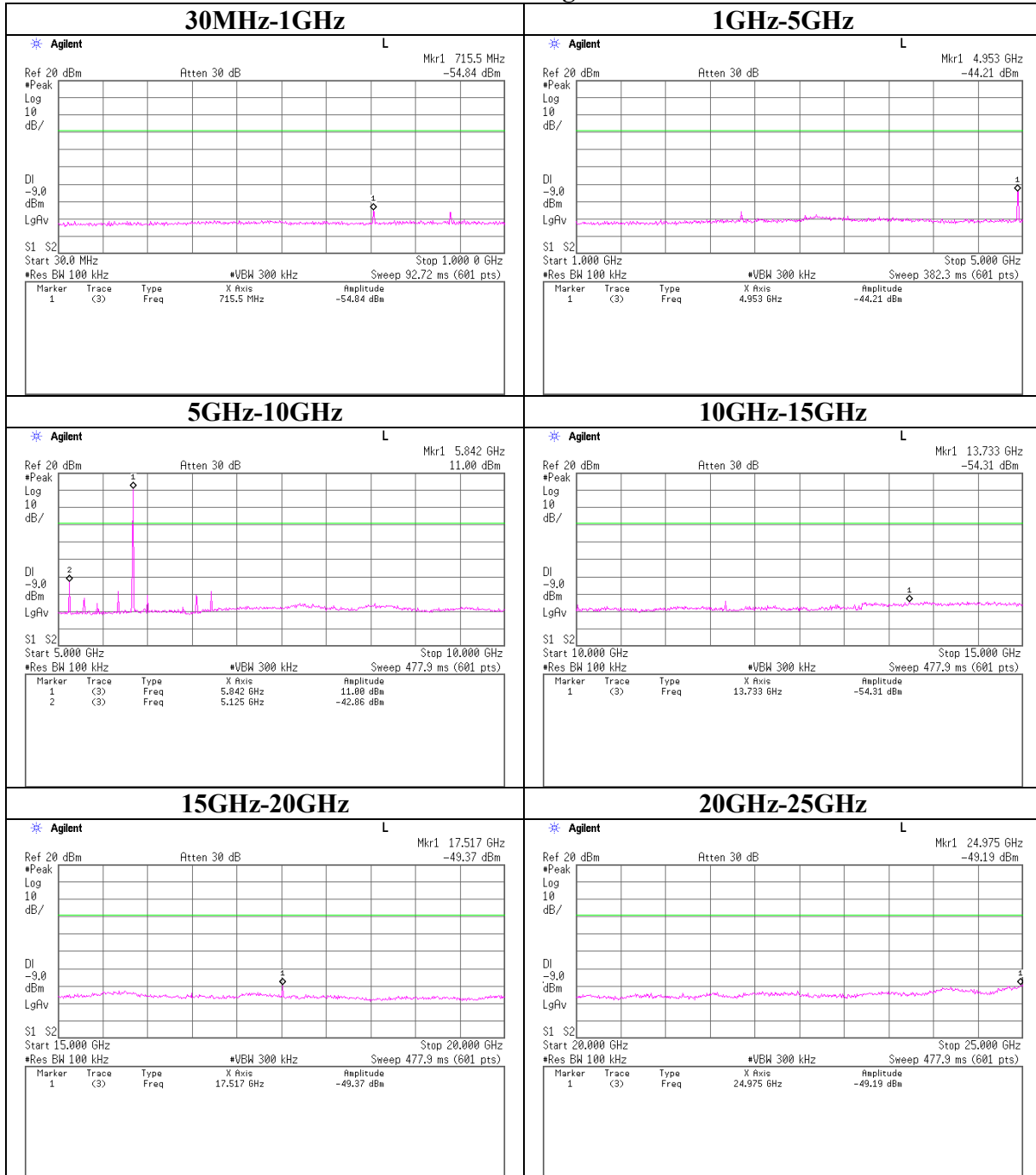

**Conducted Spurious Emission**  
**Ch:High**

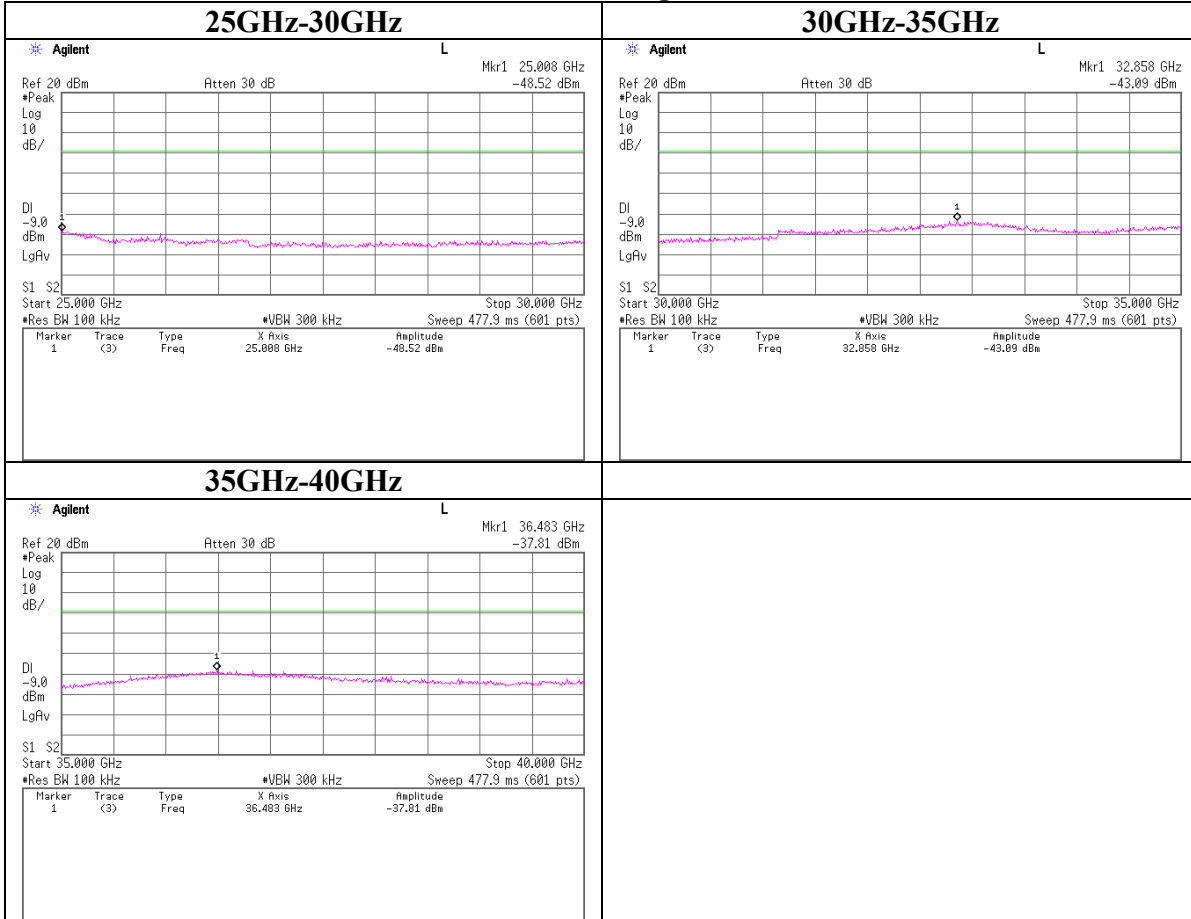

**Conducted Spurious Emission**  
**Band Edge compliance**

