

EMI TEST REPORT

Test Report No. : 26CE0011-HO-2

Applicant : Panasonic Communications Co., Ltd.
Type of Equipment : Cordless Telephone (Baset)
Model No. : KX-TG5631
FCC ID : ACJ96NKX-TG5631
Test standard : FCC Part 15 Subpart C
Section 15.207, Section 15.247 : 2005
Test Result : Complied

1. This test report shall not be reproduced in full or partial, without the written approval of UL Apex Co., Ltd.
2. The results in this report apply only to the sample tested.
3. This equipment is in compliance with the above regulation. We hereby certify that the data contain a true representation of the EMC profile.
4. The test results in this report are traceable to the national or international standards.

Date of test: October 23 to 27, 2005

Tested by: 
Kenichi Adachi
EMC Services

Yutaka Yoshida
EMC Services

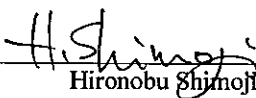
Approved by: 
Hironobu Shimoji
Group Leader of
EMC Services

CONTENTS	PAGE
SECTION 1: Client information	3
SECTION 2: Equipment under test (E.U.T.)	3
SECTION 3: Test specification, procedures & results	5
SECTION 4: Operation of E.U.T. during testing	8
SECTION 5: Conducted Emission	9
SECTION 6: Spurious Emission	10
SECTION 7: Bandwidth	11
SECTION 8: Maximum Peak Output Power	11
SECTION 9: Carrier Frequency Separation	11
SECTION 10: Number of Hopping Frequency	11
SECTION 11: Dwell time	11
APPENDIX 1: Photographs of test setup	12
Conducted Emission	12
Spurious Emission (Radiated)	13
Worst Case Position (X-axis:Horizontal / Y-axis:Vertical, Ant-0deg., Ant-Left).....	14
APPENDIX 2: Test instruments	15
APPENDIX 3: Data of EMI test	17
Conducted Emission	17
Carrier Frequency Separation	25
20dB Bandwidth	27
Number of Hopping Frequency.....	29
Dwell time.....	31
Maximum Peak Output Power.....	33
Radiated Spurious Emission.....	36
Conducted Spurious Emission.....	42

SECTION 1: Client information

Company Name	Panasonic Communications Co., Ltd.
Brand name	Panasonic
Address	1-62, 4-chome, Minoshima, Hakata-ku, Fukuoka, 812-8531 Japan
Telephone Number	+81-92-477-1405
Facsimile Number	+81-92-477-1487
Contact Person	Kunihiko Nawata

SECTION 2: Equipment under test (E.U.T.)

2.1 Identification of E.U.T.

Type of Equipment	Cordless Telephone (Baset)
Model No.	KX-TG5631
Serial No.	1 (for Radiated emissions and Conducted emissions) 2 (for Antenna terminal conducted emissions)
Country of Manufacture	Japan
Rating	AC120V 60Hz (AC Adaptor: POLV256)
Condition of EUT	Engineering prototype (Not for sale: This sample is equivalent to mass-produced items.)
Operation Clock	Main clock: 13.824 MHz
Receipt Date of Sample	October 22, 2005

2.2 Product Description

Equipment Type	Transceiver
Frequency band	Lower limit= 5725MHz, Upper limit= 5850MHz
Bandwidth & Channel spacing	Bandwidth: 79MHz Channel spacing: 891.87kHz
Type of Modulation	FHSS
Antenna Type	Colliner-Antenna
Antenna Connector Type	N/A
Antenna Gain	3dBi (Typ.)
Mode of Operation	Duplex
ITU code	F1E
Power Supply (RF Part)	DC 4.0V
Method of Frequency Generation	Synthesizer

UL Apex Co., Ltd.

Head Office EMC Lab.

4383-326 Asama-cho, Ise-shi, Mie-ken 516-0021 JAPAN

Telephone : +81 596 24 8116

Facsimile : +81 596 24 8124

MF060b(01.06.05)

FCC 15.31 (e)

This EUT provides stable voltage (DC4.0V) constantly to RF Module regardless of input voltage. Therefore, this EUT complies with the requirement.

FCC Part 15.203 Antenna requirement

It is impossible for end users to replace the antenna, because the antenna is fixed outside of the EUT. Therefore, the equipment complies with the antenna requirement of Section 15.203.

UL Apex Co., Ltd.

Head Office EMC Lab.

4383-326 Asama-cho, Ise-shi, Mie-ken 516-0021 JAPAN

Telephone : +81 596 24 8116

Facsimile : +81 596 24 8124

MF060b(01.06.05)

SECTION 3: Test specification, procedures & results

3.1 Test Specification

Test Specification : FCC Part15 Subpart C : 2005

Title : FCC 47CFR Part15 Radio Frequency Device Subpart C Intentional Radiators
Section 15.207 Conducted limits : 2005
Section 15.247 Operation within the bands 902-928MHz,
2400-2483.5MHz, and 5725-5850MHz : 2005

3.2 Procedures and results

No.	Item	Test Procedure	Specification	Remarks	Deviation	Worst Margin*0)	Results
1	Conducted emission	ANSI C63.4:2003 7. AC powerline conducted emission measurements	Section 15.207	-	N/A	5.6dB 0.70248MHz AV, N	Complied
2	Carrier Frequency Separation	ANSI C63.4:2003 13. Measurement of intentional radiators	Section 15.247(a)(1)	Conducted	N/A	*See data.	Complied
3	20dB Bandwidth	ANSI C63.4:2003 13. Measurement of intentional radiators	Section 15.247(a)(1)	Conducted	N/A		Complied
4	Number of Hopping Frequency	ANSI C63.4:2003 13. Measurement of intentional radiators	Section 15.247(a)(1)(iii)	Conducted	N/A		Complied
5	Dwell time	ANSI C63.4:2003 13. Measurement of intentional radiators	Section 15.247(a)(1)(iii)	Conducted	N/A		Complied
6	Maximum Peak Output Power	ANSI C63.4:2003 13. Measurement of intentional radiators	Section 15.247(b)(1)	Conducted	N/A		Complied
7	Band Edge Compliance	ANSI C63.4:2003 13. Measurement of intentional radiators	Section 15.247(d)	Conducted	N/A		Complied
8	Spurious Emission	ANSI C63.4:2003 13. Measurement of intentional radiators	Section 15.247(d)	Conducted/ Radiated	N/A	5.2dB 11677.8MHz PK, Ver.	Complied

Note: UL Apex's EMI Work Procedures No.QPM05 and QPM15.

*0) The result is rounded off to the second decimal place. Therefore, there may be 0.1 difference for the result.

Uncertainty:

Conducted Emission

The measurement uncertainty (with a 95% confidence level) for this test is ± 1.3 dB.

The data listed in this test report has enough margin, more than the site margin.

Spurious Emission (Radiated)

The measurement uncertainty (with a 95% confidence level) for this test using Biconical antenna is ± 4.5 dB(3m)/ ± 4.7 dB(10m).

The measurement uncertainty (with a 95% confidence level) for this test using Logperiodic antenna is ± 5.2 dB(3m)/ ± 3.8 dB(10m).

The measurement uncertainty (with a 95% confidence level) for this test using Horn antenna is ± 6.6 dB.

The data listed in this report meets the limits unless the uncertainty is taken into consideration.

Other test except Conducted Emission and Spurious Emission (Radiated)

The measurement uncertainty (with a 95% confidence level) for this test is ± 3.0 dB.

*These tests were also referred to FCC Public Notice DA 00-705 "Guidance on Measurement for Frequency Hopping Spread Spectrum Systems".

*These tests were performed without any deviations from test procedure except for additions or exclusions.

UL Apex Co., Ltd.

Head Office EMC Lab.

4383-326 Asama-cho, Ise-shi, Mie-ken 516-0021 JAPAN

Telephone : +81 596 24 8116

Facsimile : +81 596 24 8124

MF060b(01.06.05)

3.3 Test Location

UL Apex Co., Ltd. Head Office EMC Lab. *NVLAP Lab. code: 200572-0
4383-326 Asama-cho, Ise-shi, Mie-ken 516-0021 JAPAN
Telephone : +81 596 24 8116
Facsimile : +81 596 24 8124

	FCC Registration Number	IC Registration Number	Width x Depth x Height (m)	Size of reference ground plane (m) / horizontal conducting plane	Other rooms
No.1 semi-anechoic chamber	313583	IC4247A	19.2 x 11.2 x 7.7m	7.0 x 6.0m	Preparation room
No.2 semi-anechoic chamber	846015	IC4247A-2	7.5 x 5.8 x 5.2m	4.0 x 4.0m	-
No.3 shielded room	-	-	4.7 x 7.5 x 2.7m	4.7 x 7.5m	-
No.4 measurement room	-	-	3.1 x 5.0 x 2.7m	N/A	-

* Size of vertical conducting plane (for Conducted Emission test) : 2.0 x 2.0m for No.1 and No.2 semi-anechoic and No.3 shielded room.

3.4 Test set up, Test instruments and Data of EMI

Refer to APPENDIX 1 to 3.

SECTION 4: Operation of E.U.T. during testing

4.1 Operating Modes

The mode is used : [FHSS]
Transmitting mode
Low Channel : 5759.70240MHz
Mid Channel : 5798.05084MHz
High Channel : 5838.18697MHz
Receiving mode

4.2 Configuration and peripherals

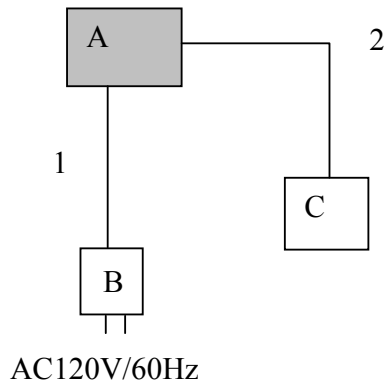

* Cabling was taken into consideration and test data was taken under worse case conditions.

Description of EUT and Support equipment

No.	Item	Model number	Serial number	Manufacturer	FCC ID
A	Cordless Telephone (Baset)	KX-TG5631	1 (for Radiated and Conducted emissions) 2 (for Antenna terminal conducted emissions)	Panasonic Communications	ACJ96NKX-TG5631
B	AC Adapter	PQLV256	-	Panasonic Communications	-
C	Facsimile Equipment	FQ-70	17104455	Sharp	-

List of cables used

No.	Name	Length (m)	Shield
1	DC Cable	2.0	N
2	Tel Code	1.8	N

SECTION 5: Conducted Emission

Test Procedure and conditions

EUT was placed on a platform of nominal size, 1.0m by 1.0m, raised 80cm above the conducting ground plane. The rear of tabletop was located 40cm to the vertical conducting plane. The rear of EUT, including peripherals aligned and flushed with rear of tabletop. All other surfaces of tabletop were at least 80cm from any other grounded conducting surface. EUT was located 80cm from a Line Impedance Stabilization Network (LISN)/ Artificial mains Network (AMN) and excess AC cable was bundled in center.

For the tests on EUT itself (as a stand alone equipment)

Each EUT current-carrying power lead, except the ground (safety) lead, was individually connected through a LISN/(AMN) to the input power source. All unused 50ohm connectors of the LISN(AMN) were resistivity terminated in 50ohm when not connected to the measuring equipment.

The AC Mains Terminal Continuous disturbance Voltage has been measured with the EUT in a Semi Anechoic Chamber or a Measurement Room.

The EUT was connected to a LISN (AMN).

An overview sweep with peak detection has been performed.

Detector : CISPR quasi-peak and average detector (IF BW 9 kHz)
Measurement range : 0.15-30MHz
Test data : APPENDIX 3
Test result : Pass

UL Apex Co., Ltd.

Head Office EMC Lab.

4383-326 Asama-cho, Ise-shi, Mie-ken 516-0021 JAPAN

Telephone : +81 596 24 8116

Facsimile : +81 596 24 8124

MF060b(01.06.05)

SECTION 6: Spurious Emission

[Conducted]

Test Procedure

The Out of Band Emission was measured with a spectrum analyzer connected to the antenna port.

Test data : APPENDIX 3

Test result : Pass

[Radiated]

Test Procedure

EUT was placed on a platform of nominal size, 0.5m by 1.0m, raised 80cm above the conducting ground plane.

The Radiated Electric Field Strength intensity has been measured in a Semi Anechoic Chamber with a ground plane and at a distance of 3m(Below 18GHz) and 1m(Upper 18GHz) and 0.5m (Upper 26.5GHz).

The height of the measuring varied between 1 and 4m and EUT was rotated a full revolution in order to obtain the maximum value of the electric field intensity.

The measurements were performed for both vertical and horizontal antenna polarization with the Test Receiver, or the Spectrum Analyzer (in linear mode).

The test was made with the detector (RBW/VBW) in the following table.

When using Spectrum analyzer, the test was made with adjusting span to zero by using peak hold.

In any 100kHz bandwidth outside the frequency band in which the spread spectrum intentional radiator is operating, the radio frequency power that is produced by the intentional radiator confirmed 20dB below that in the 100kHz bandwidth within the band that contains the highest level of the desired power, based on a radiated measurement.

20dBc was applied to the frequency over the limit of FCC 15.209 and outside the restricted band of 15.205.

Frequency	Below 1GHz	Above 1GHz
Instrument used	Test Receiver / Spectrum Analyzer	Spectrum Analyzer
Detector	QP: BW 120kHz(T/R)	PK: RBW:1MHz/VBW: 1MHz
IF Bandwidth	20dBc : RBW: 100kHz VBW: 300kHz (S/A)	AV: RBW:1MHz/VBW:10Hz 20dBc : RBW:100kHz/VBW:300kHz

- The carrier level and noise levels were confirmed at each position of X, Y and Z axes of EUT to see the position of maximum noise, and the test was made at the position that has the maximum noise.

Test data : APPENDIX 3

Test result : Pass

UL Apex Co., Ltd.

Head Office EMC Lab.

4383-326 Asama-cho, Ise-shi, Mie-ken 516-0021 JAPAN

Telephone : +81 596 24 8116

Facsimile : +81 596 24 8124

MF060b(01.06.05)

SECTION 7: Bandwidth

Test Procedure

The bandwidth was measured with a spectrum analyzer connected to the antenna port.

Test data : APPENDIX 3
Test result : Pass

SECTION 8: Maximum Peak Output Power

Test Procedure

The Maximum Peak Output Power was measured with a spectrum analyzer connected to the antenna port.

Test data : APPENDIX 3
Test result : Pass

SECTION 9: Carrier Frequency Separation

Test Procedure

The carrier frequency separation was measured with a spectrum analyzer connected to the antenna port.

Test data : APPENDIX 3
Test result : Pass

SECTION 10: Number of Hopping Frequency

Test Procedure

The Number of Hopping Frequency was measured with a spectrum analyzer connected to the antenna port.

Test data : APPENDIX 3
Test result : Pass

SECTION 11: Dwell time

Test Procedure

The Dwell time was measured with a spectrum analyzer connected to the antenna port.

Test data : APPENDIX 3
Test result : Pass

APPENDIX 1: Photographs of test setup

Conducted Emission
Front



Rear



Spurious Emission (Radiated)

Front



Rear



Worst Case Position (X-axis:Horizontal / Y-axis:Vertical, Ant-0deg., Ant-Left)

X-axis



X-axis, Left-Ant-0 deg.



Y-axis



X-axis, Left-Ant-90 deg.



Z-axis



APPENDIX 2: Test instruments

EMI test equipment

Control No.	Instrument	Manufacturer	Model No	Test Item	Calibration Date * Interval(month)
MAEC-01	Anechoic Chamber	TDK	Semi Anechoic Chamber 10m	RE	2004/11/13 * 12
MTR-01	Test Receiver	Rohde & Schwarz	ESI40	RE	2004/11/12 * 12
MPA-05	Pre Amplifier	TSJ	TSJ 1-26.5GHz PreAmp	RE	2005/07/08 * 12
MCC-18	Microwave Cable 1G-26.5GHz	Suhner	SUCOFLEX 104	RE	2005/02/03 * 12
MCC-26	Microwave Cable 1G-26.5GHz	Suhner	SUCOFLEX104	RE	2005/08/30 * 12
MBF-03	SHF Bandpass Filter	M-City	13GHz BPF	RE	2005/05/20 * 12
MAT-21	Attenuator(20dB)(above1GHz)	HIROSE ELECTRIC CO.,LTD.	AT-120	RE	2005/01/11 * 12
MHA-05	Horn Antenna	Schwarzbeck	BBHA9120D	RE	2005/01/10 * 12
MHA-01	Horn Antenna	EMCO	3160-09	RE	2005/01/10 * 12
MCC-17	Microwave Cable 1G-50GHz	Suhner	SUCOFLEX 101	RE	2005/02/03 * 12
MPA-03	Microwave System Power Amplifier	Agilent	83050A	RE	2005/05/11 * 12
MCC-14	Microwave Cable 1G-50GHz	Suhner	SUCOFLEX 101	RE	2005/02/03 * 12
MHA-03	Horn Antenna	EMCO	3160-10	RE	2005/01/10 * 12
MSA-03	Spectrum Analyzer	Agilent	E4448A	AT	2005/09/16 * 12
MAT-24	Attenuator(10dB)(above1GHz)	Agilent	8493C	AT	2005/06/03 * 12
MCC-22	Microwave Cable 1G-50GHz	Storm	421-011 (90-011-080)	AT	2005/04/29 * 12
MAEC-02	Anechoic Chamber	TDK	Semi Anechoic Chamber 3m	RE	2005/04/11 * 12
MCC-04	Microwave Cable 1G-50GHz	Storm	421-011 (90-1394-079)	RE	2005/01/05 * 12
MHA-04	Horn Antenna	EMCO	3160-10	RE	2005/01/10 * 12
MSA-04	Spectrum Analyzer	Agilent	E4448A	RE	2005/05/19 * 12
MBA-02	Biconical Antenna	Schwarzbeck	BBA9106	RE	2005/10/10 * 12
MLA-02	Logperiodic Antenna	Schwarzbeck	USLP9143	RE	2005/10/14 * 12
MAT-07	Attenuator(6dB)	Weinschel Corp	2	RE	2004/12/16 * 12
MCC-12	Coaxial Cable	Fujikura/Agilent	-	RE	2005/02/24 * 12
MPA-09	Pre Amplifier	Agilent	8447D	RE	2005/09/07 * 12
MCC-13	Coaxial Cable	Fujikura/Agilent	-	CE	2005/02/24 * 12
MLS-06	LISN(AMN)	Schwarzbeck	NSLK8127	CE (EUT)	2005/02/04 * 12
MLS-07	LISN(AMN)	Schwarzbeck	NSLK8127	CE (AE)	2005/02/04 * 12
MTA-04	Termination	MCL	NTRM-50	CE	2005/02/03 * 12
MTR-02	Test Receiver	Rohde & Schwarz	ESCS30	RE	2005/02/02 * 12

UL Apex Co., Ltd.

Head Office EMC Lab.

4383-326 Asama-cho, Ise-shi, Mie-ken 516-0021 JAPAN

Telephone : +81 596 24 8116

Facsimile : +81 596 24 8124

MF060b(01.06.05)

All equipment is calibrated with traceable calibrations. Each calibration is traceable to the national or international standards.

Test Item:

CE: Conducted Emission

RE: Radiated Spurious Emission

AT: Antenna Terminal Measurement

UL Apex Co., Ltd.

Head Office EMC Lab.

4383-326 Asama-cho, Ise-shi, Mie-ken 516-0021 JAPAN

Telephone : +81 596 24 8116

Facsimile : +81 596 24 8124

MF060b(01.06.05)

APPENDIX 3: Data of EMI test

Conducted Emission

DATA OF CONDUCTED EMISSION TEST

UL Apex Co., Ltd. Head Office EMC Lab. No.2 Semi Anechoic Chamber
 Date : 2005/10/26 17:13:36

Applicant	: Panasonic Communications Co., Ltd.	Report No.	: 26CE0011-HO
Kind of EUT	: Cordless Telephone (Baset)	Power	: AC 120V / 60Hz (AC Adaptor)
Model No.	: KX-TG5631	Temp./Humi.	: 24 deg.C. / 48 %
Serial No.	: 1	Operator	: Kenichi Adachi

Mode / Remarks : Tx5759. 70240MHz / Ant: Left (Worst)

LIMIT : FCC15C § 15.207 (QP) / RSS-Gen / RSS-210
 FCC15C § 15.207 (AV) / RSS-Gen / RSS-210

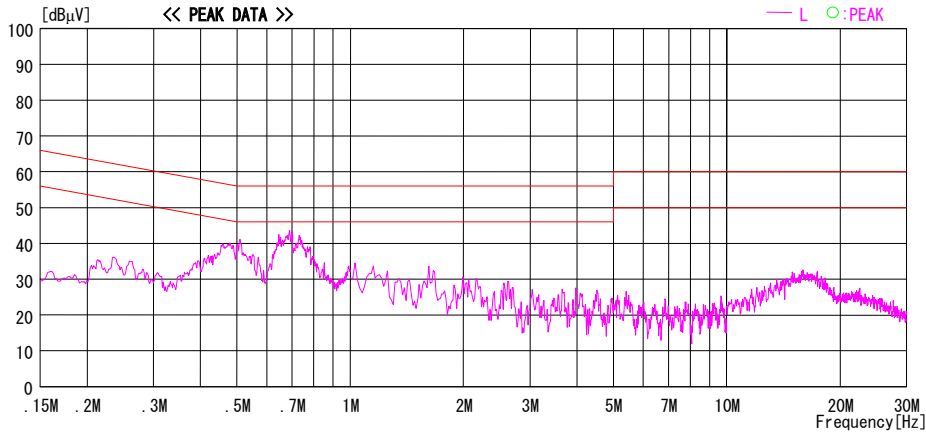
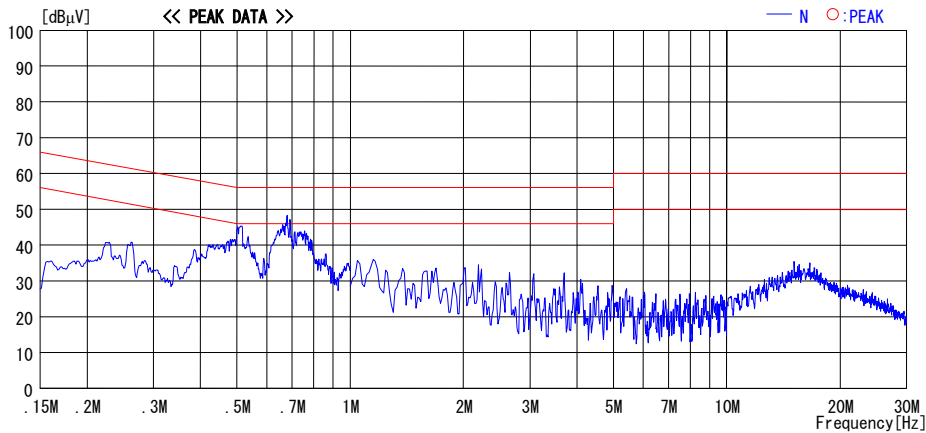

CHART:WITH FACTOR, Peak hold data. Data is uncorrected.
 Except for the above table : adequate margin data below the limits.

Conducted Emission

DATA OF CONDUCTED EMISSION TEST

UL Apex Co., Ltd. Head Office EMC Lab. No.2 Semi Anechoic Chamber
 Date : 2005/10/26 17:29:13

Applicant	: Panasonic Communications Co.,Ltd.	Report No.	: 26CE0011-HO
Kind of EUT	: Cordless Telephone (Baset)	Power	: AC 120V / 60Hz (AC Adaptor)
Model No.	: KX-TG5631	Temp./Humi.	: 24 deg.C. / 48 %
Serial No.	: 1	Operator	: Kenichi Adachi

Mode / Remarks: Tx5798.05084MHz / Ant: Left (Worst)

LIMIT : FCC15C § 15.207 (QP) / RSS-Gen / RSS-210
 FCC15C § 15.207 (AV) / RSS-Gen / RSS-210

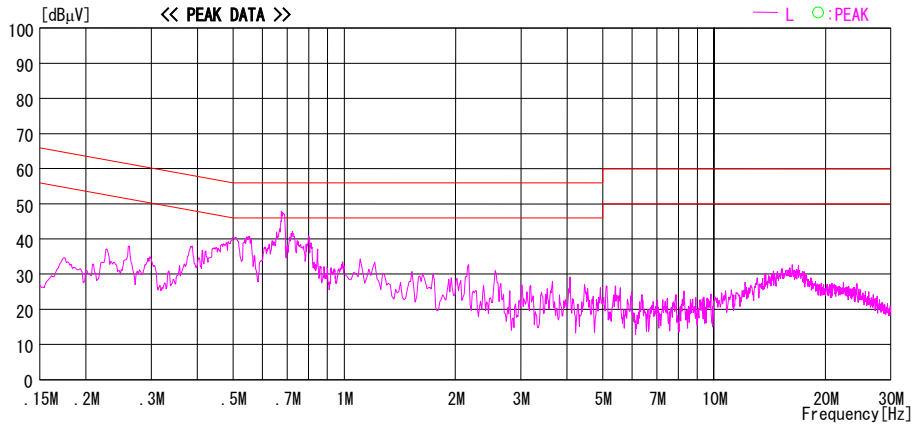
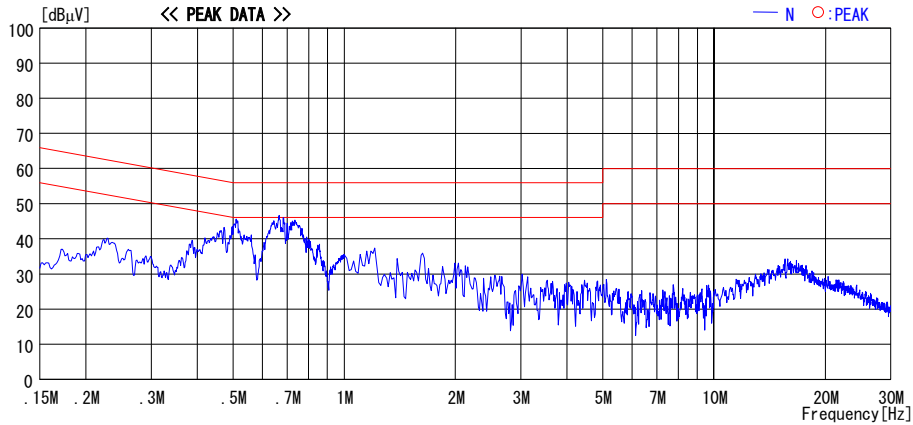

CHART:WITH FACTOR, Peak hold data,Data is uncorrected.
 Except for the above table : adequate margin data below the limits.

Conducted Emission

DATA OF CONDUCTED EMISSION TEST

UL Apex Co., Ltd. Head Office EMC Lab. No. 2 Semi Anechoic Chamber
 Date : 2005/10/26 17:33:39

Applicant : Panasonic Communications Co., Ltd. Kind of EUT : Cordless Telephone (Baset)	Report No. : 26CE0011-HO Power : AC 120V / 60Hz (AC Adaptor)
Model No. : KX-TG5631 Serial No. : 1	Temp./Humi. : 24 deg. C. / 48 % Operator : Kenichi Adachi

Mode / Remarks : Tx5838.18697MHz / Ant: Left (Worst)

LIMIT : FCC15C § 15.207 (QP) / RSS-Gen / RSS-210
 FCC15C § 15.207 (AV) / RSS-Gen / RSS-210

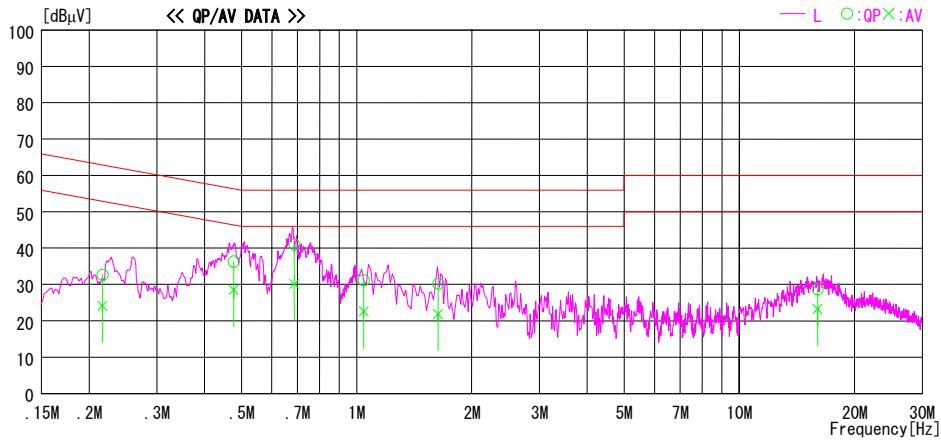
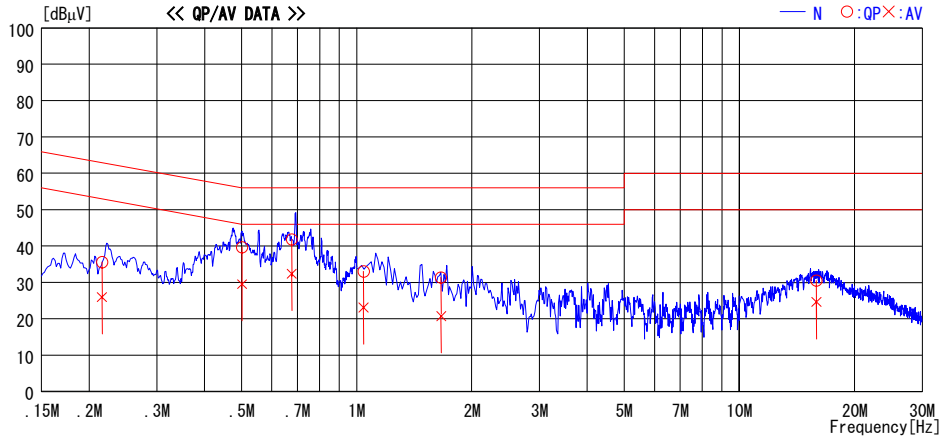

CHART: WITH FACTOR, Peak hold data. Data is uncorrected.
 Except for the above table : adequate margin data below the limits.

Conducted Emission

DATA OF CONDUCTED EMISSION TEST

UL Apex Co., Ltd. Head Office EMC Lab. No.2 Semi Anechoic Chamber
Date : 2005/10/26 17:33:39

Applicant : Panasonic Communications Co.,Ltd. Report No. : 26CE0011-HO
Kind of EUT : Cordless Telephone (Baset) Power : AC 120V / 60Hz (AC Adaptor)
Model No. : KX-TG5631 Temp./Humi. : 24 deg.C. / 48 %
Serial No. : 1 Operator : Kenichi Adachi

Mode / Remarks : Tx5838.18697MHz / Ant: Left (Worst)

LIMIT : FCC15C § 15.207 (QP) / RSS-Gen / RSS-210
FCC15C § 15.207 (AV) / RSS-Gen / RSS-210

Frequency [MHz]	Reading Level		Corr. Factor	Results		Limit		Margin		Phase
	QP	AV		QP	AV	QP	AV	QP	AV	
	[dBuV]	[dBuV]	[dB]	[dBuV]	[dBuV]	[dBuV]	[dBuV]	[dB]	[dB]	
0.21590	35.5	25.8	0.1	35.6	25.9	63.0	53.0	27.4	27.1	N
0.50114	39.5	29.3	0.2	39.7	29.5	56.0	46.0	16.3	16.5	N
0.67600	41.6	32.2	0.2	41.8	32.4	56.0	46.0	14.2	13.6	N
1.04144	32.7	22.8	0.3	33.0	23.1	56.0	46.0	23.0	22.9	N
1.66184	31.0	20.3	0.4	31.4	20.7	56.0	46.0	24.6	25.3	N
15.88045	28.9	23.0	1.6	30.5	24.6	60.0	50.0	29.5	25.4	N
0.21672	32.6	24.1	0.1	32.7	24.2	62.9	52.9	30.2	28.7	L
0.47736	36.3	28.5	0.1	36.4	28.6	56.4	46.4	20.0	17.8	L
0.68728	40.8	30.0	0.2	41.0	30.2	56.0	46.0	15.0	15.8	L
1.04399	30.9	22.3	0.3	31.2	22.6	56.0	46.0	24.8	23.4	L
1.63286	29.9	21.5	0.4	30.3	21.9	56.0	46.0	25.7	24.1	L
16.00800	27.2	21.7	1.6	28.8	23.3	60.0	50.0	31.2	26.7	L

CHART:WITH FACTOR,Peak hold data.Data is uncorrected.
Except for the above table : adequate margin data below the limits.

Conducted Emission

DATA OF CONDUCTED EMISSION TEST

UL Apex Co., Ltd. Head Office EMC Lab. No.2 Semi Anechoic Chamber
 Date : 2005/10/26 17:17:39

Applicant : Panasonic Communications Co., Ltd.	Report No. : 26CE0011-HO
Kind of EUT : Cordless Telephone (Basetset)	Power : AC 120V / 60Hz (AC Adaptor)
Model No. : KX-TG5631	Temp./Humi. : 24 deg. C. / 48 %
Serial No. : 1	Operator : Kenichi Adachi

Mode / Remarks: Tx5759.70240MHz / Ant: Left(Worst) / with Battery charging

LIMIT : FCC15C § 15.207 (QP) / RSS-Gen / RSS-210
 FCC15C § 15.207 (AV) / RSS-Gen / RSS-210

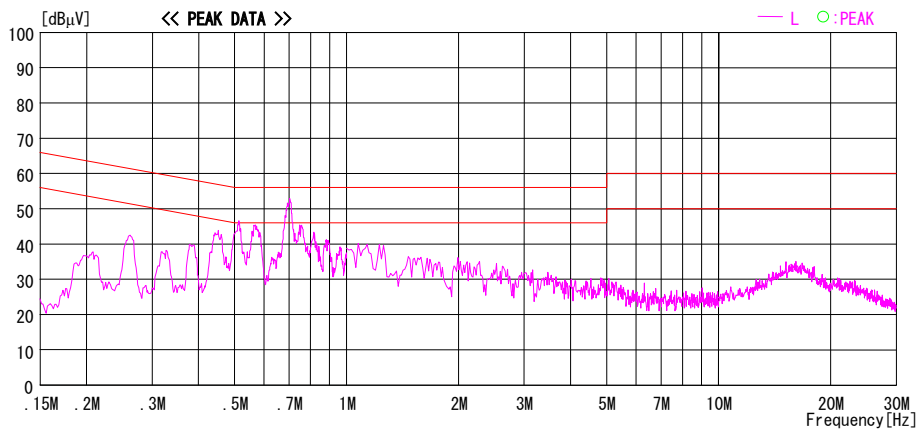
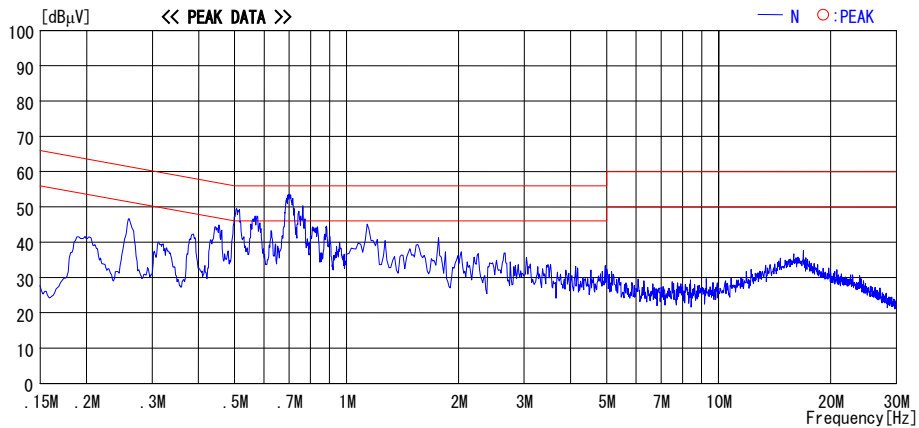

CHART: WITH FACTOR, Peak hold data. Data is uncorrected.
 Except for the above table : adequate margin data below the limits.

Conducted Emission

DATA OF CONDUCTED EMISSION TEST

UL Apex Co., Ltd. Head Office EMC Lab. No.2 Semi Anechoic Chamber
 Date : 2005/10/26 17:26:06

Applicant : Panasonic Communications Co.,Ltd.	Report No. : 26CE0011-HO
Kind of EUT : Cordless Telephone (Baset)	Power : AC 120V / 60Hz (AC Adaptor)
Model No. : KX-TG5631	Temp./Humi. : 24 deg.C / 48 %
Serial No. : 1	Operator : Kenichi Adachi

Mode / Remarks: Tx5798.05084MHz / Ant: Left(Worst) / with Battery charging

LIMIT : FCC15C § 15.207 (QP) / RSS-Gen / RSS-210
 FCC15C § 15.207 (AV) / RSS-Gen / RSS-210

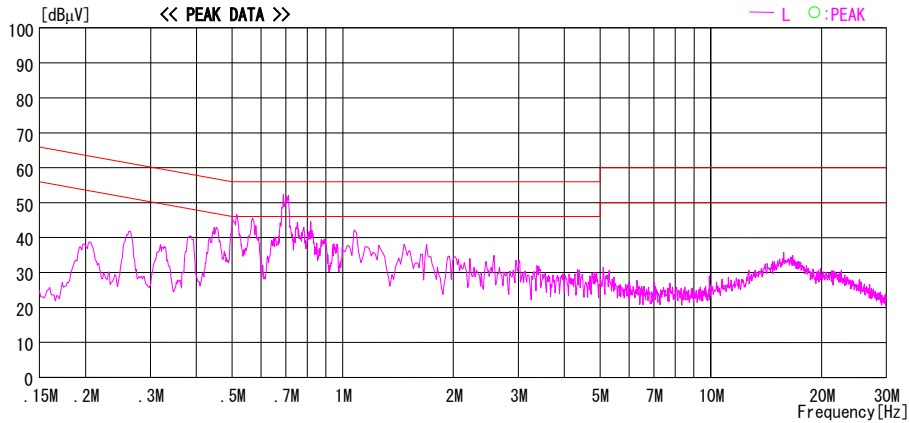
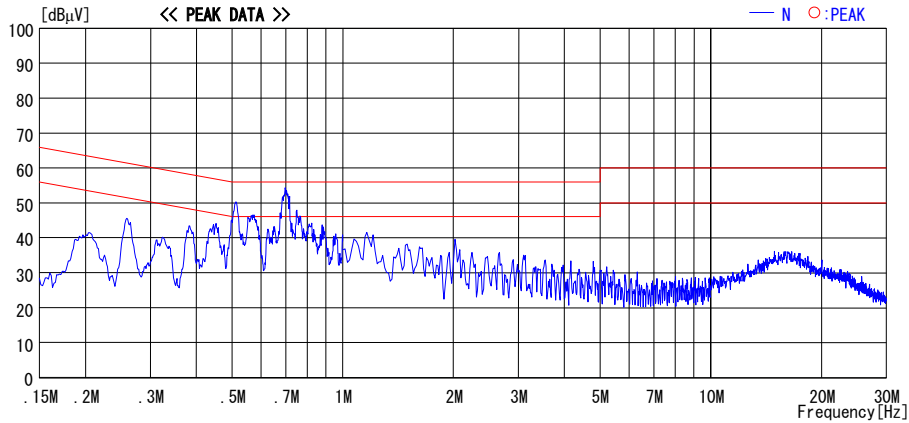

CHART:WITH FACTOR,Peak hold data.Data is uncorrected.
 Except for the above table : adequate margin data below the limits.

Conducted Emission

DATA OF CONDUCTED EMISSION TEST

UL Apex Co., Ltd. Head Office EMC Lab. No.2 Semi Anechoic Chamber
Date : 2005/10/26 17:36:58

Applicant	: Panasonic Communications Co., Ltd.	Report No.	: 26CE0011-HO
Kind of EUT	: Cordless Telephone (Baset)	Power	: AC 120V / 60Hz (AC Adaptor)
Model No.	: KX-TG5631	Temp./Humi.	: 24 deg.C. / 48 %
Serial No.	: 1	Operator	: Kenichi Adachi

Mode / Remarks: Tx5838.18697MHz / Ant: Left(Worst) / with Battery charging

LIMIT : FCC15C § 15.207 (QP) / RSS-Gen / RSS-210
 FCC15C § 15.207 (AV) / RSS-Gen / RSS-210

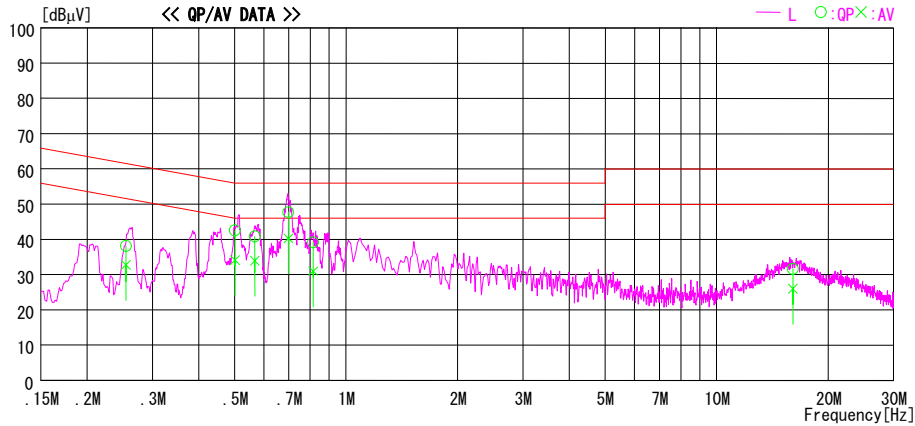
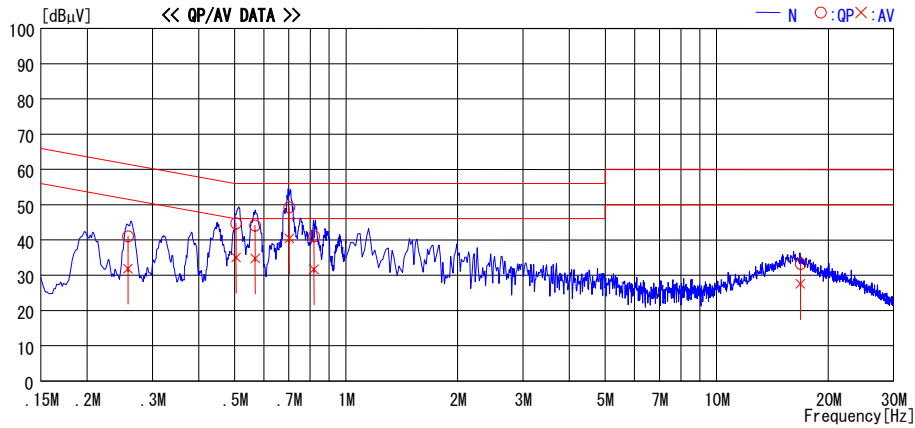

CHART: WITH FACTOR, Peak hold data. Data is uncorrected.
 Except for the above table : adequate margin data below the limits.

Conducted Emission

DATA OF CONDUCTED EMISSION TEST

UL Apex Co., Ltd. Head Office EMC Lab. No.2 Semi Anechoic Chamber
Date : 2005/10/26 17:36:58

Applicant : Panasonic Communications Co., Ltd. Report No. : 26CE0011-HO
Kind of EUT : Cordless Telephone (Baset) Power : AC 120V / 60Hz (AC Adaptor)
Model No. : KX-TG5631 Temp./Humi. : 24 deg.C. / 48 %
Serial No. : 1 Operator : Kenichi Adachi

Mode / Remarks : Tx5838.18697MHz / Ant: Left(Worst) / with Battery charging

LIMIT : FCC15C § 15.207 (QP) / RSS-Gen / RSS-210
FCC15C § 15.207 (AV) / RSS-Gen / RSS-210

Frequency [MHz]	Reading Level		Corr. Factor	Results		Limit		Margin		Phase
	QP	AV		QP	AV	QP	AV	QP	AV	
	[dBuV]	[dBuV]	[dB]	[dBuV]	[dBuV]	[dBuV]	[dBuV]	[dB]	[dB]	
0.25769	41.0	31.8	0.1	41.1	31.9	61.5	51.5	20.4	19.6	N
0.50472	44.5	34.8	0.2	44.7	35.0	56.0	46.0	11.3	11.0	N
0.56844	43.9	34.6	0.2	44.1	34.8	56.0	46.0	11.9	11.2	N
0.70248	49.0	40.1	0.3	49.3	40.4	56.0	46.0	6.7	5.6	N
0.81812	40.7	31.4	0.3	41.0	31.7	56.0	46.0	15.0	14.3	N
16.82746	31.5	25.8	1.7	33.2	27.5	60.0	50.0	26.8	22.5	N
0.25473	38.1	32.7	0.1	38.2	32.8	61.6	51.6	23.4	18.8	L
0.50146	42.4	34.0	0.2	42.6	34.2	56.0	46.0	13.4	11.8	L
0.56727	40.7	33.8	0.2	40.9	34.0	56.0	46.0	15.1	12.0	L
0.69932	47.5	40.0	0.3	47.8	40.3	56.0	46.0	8.2	5.7	L
0.81526	39.0	30.7	0.3	39.3	31.0	56.0	46.0	16.7	15.0	L
16.05255	30.1	24.4	1.6	31.7	26.0	60.0	50.0	28.3	24.0	L

CHART:WITH FACTOR, Peak hold data. Data is uncorrected.
Except for the above table : adequate margin data below the limits.

Carrier Frequency Separation

UL Apex Co., Ltd.
Head Office EMC Lab. No.3 Shielded Room

COMPANY	: Panasonic Communications Co.,Ltd.	REGULATION	: FCC Part15 Subpart C 15.247(a)(1)
EQUIPMENT	: Cordless Telephone (Baset)	TEST DISTANCE	: -
MODEL	: KX-TG5631	DATE	: 10/24/2005
S/N	: 2	TEMPERATURE	: 23deg.C
POWER	: AC 120 V / 60Hz	HUMIDITY	: 43%
MODE	: Tx(Hopping on)	ENGINEER	: Kenichi Adachi

Ch	Freq. [MHz]	Channel separation [MHz]	Limit
Low	5759.7	0.892	>20dB Bandwidth and 25[kHz]
Mid	5798.1	0.910	>20dB Bandwidth and 25[kHz]
High	5838.2	0.885	>20dB Bandwidth and 25[kHz]

Carrier Frequency Separation

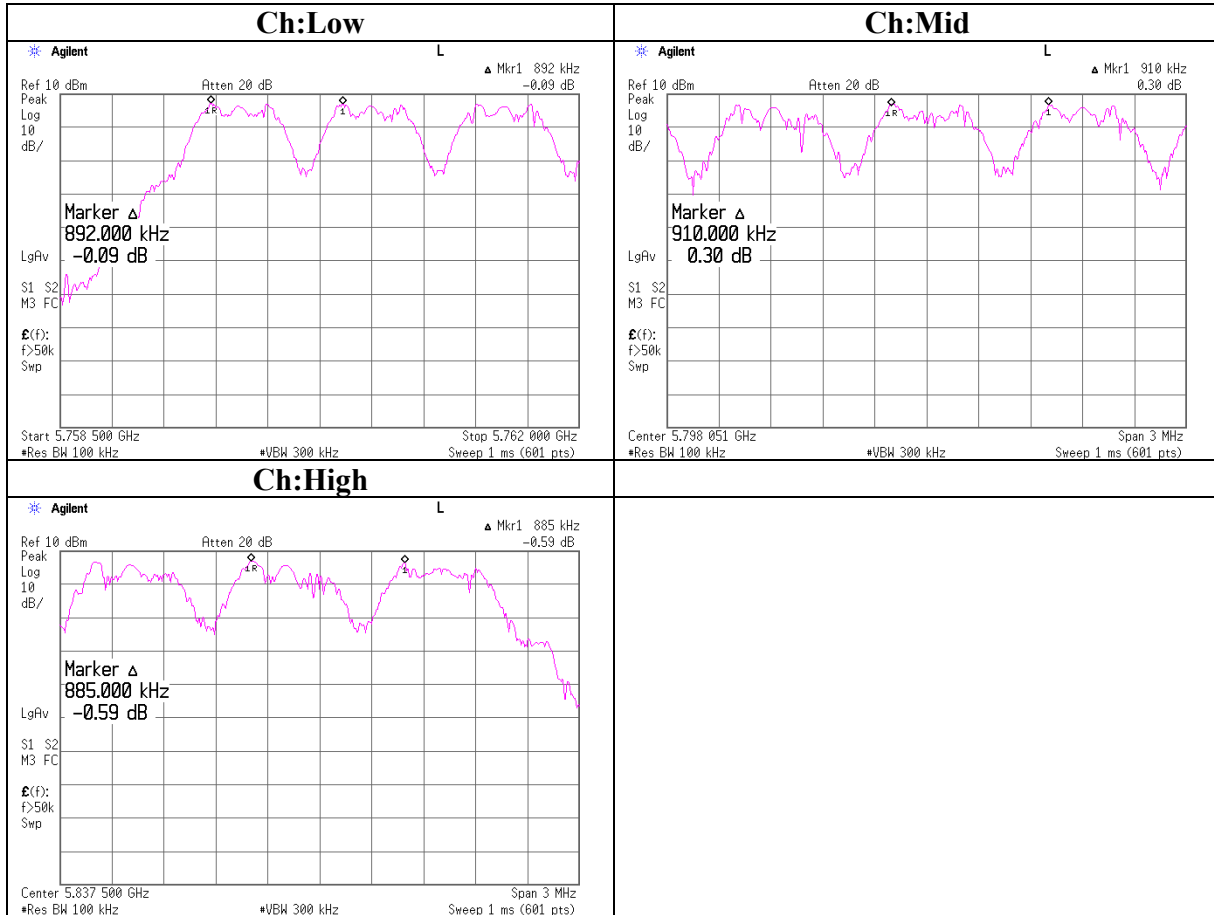

20dB Bandwidth

UL Apex Co., Ltd.
Head Office EMC Lab. No.3 Shielded Room

COMPANY	: Panasonic Communications Co.,Ltd.	REGULATION	: FCC Part15 Subpart C 15.247(a)(1)(ii)
EQUIPMENT	: Cordless Telephone (Baset)	TEST DISTANCE	: -
MODEL	: KX-TG5631	DATE	: 10/24/2005
S/ N	: 2	TEMPERATURE	: 23deg.C
POWER	: AC 120 V / 60Hz	HUMIDITY	: 43%
MODE	: Tx(Hopping off)	ENGINEER	: Kenichi Adachi
	: Worst antenna		

Left antenna

Ch	Freq.	20dB Bandwidth	Limit
	[MHz]	[MHz]	[MHz]
Low	5759.7	0.676	≤ 1
Mid	5798.1	0.670	≤ 1
High	5838.2	0.699	≤ 1

20dB Bandwidth

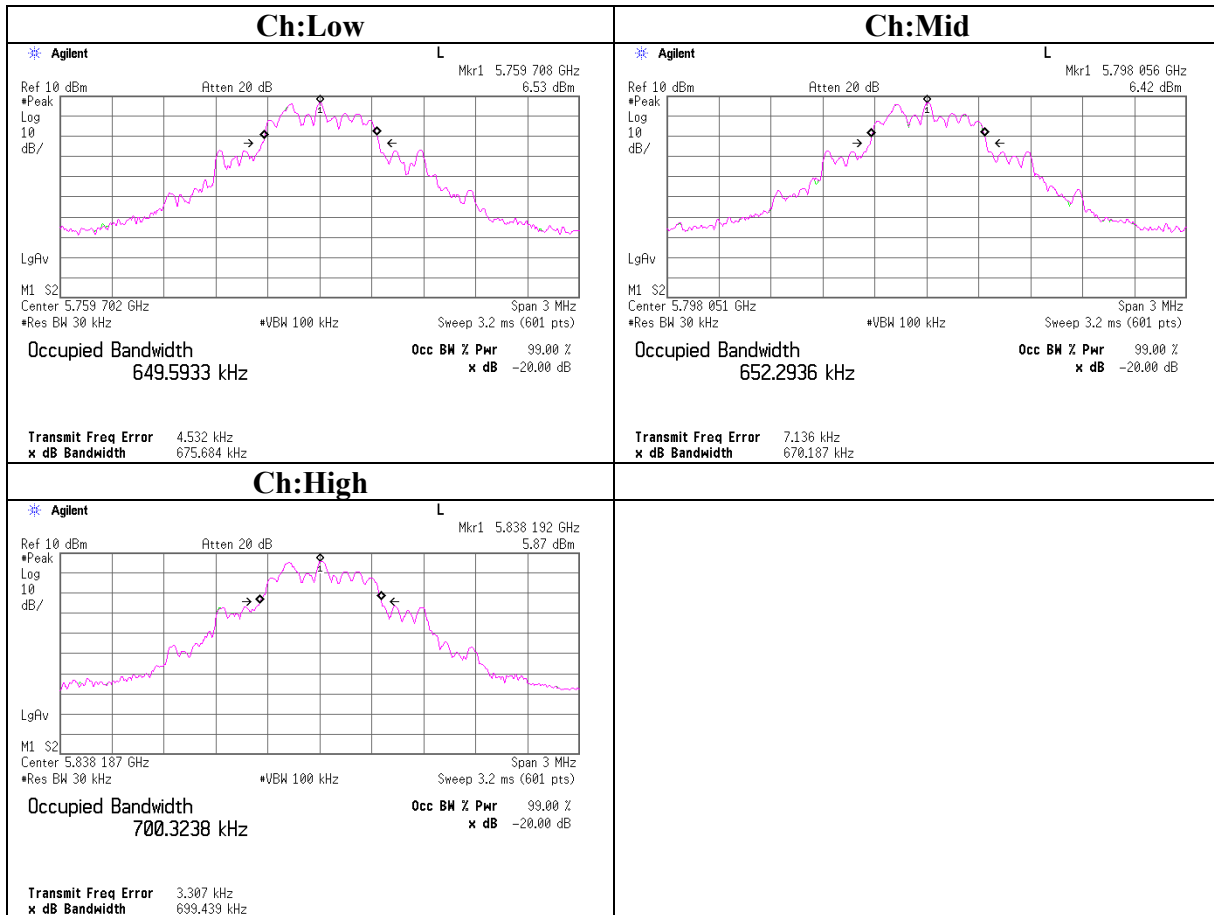

Number of Hopping Frequency

UL Apex Co., Ltd.
Head Office EMC Lab. No.3 Shielded Room

COMPANY : Panasonic Communications REGULATION : FCC Part15 Subpart C 15.247(a)(1)(ii)
EQUIPMENT : Cordless Telephone (Baset) TEST DISTANCE : -
MODEL : KX-TG5631 DATE : 10/24/2005
S/ N : 2 TEMPERATURE : 23deg.C
POWER : AC 120 V / 60Hz HUMIDITY : 43%
MODE : Tx(Hopping on) ENGINEER : Kenichi Adachi

Mode	Number of channel [time]	Limit [time]
Tx(Hoppng on)	75	≥ 75

Number of Hopping Frequency

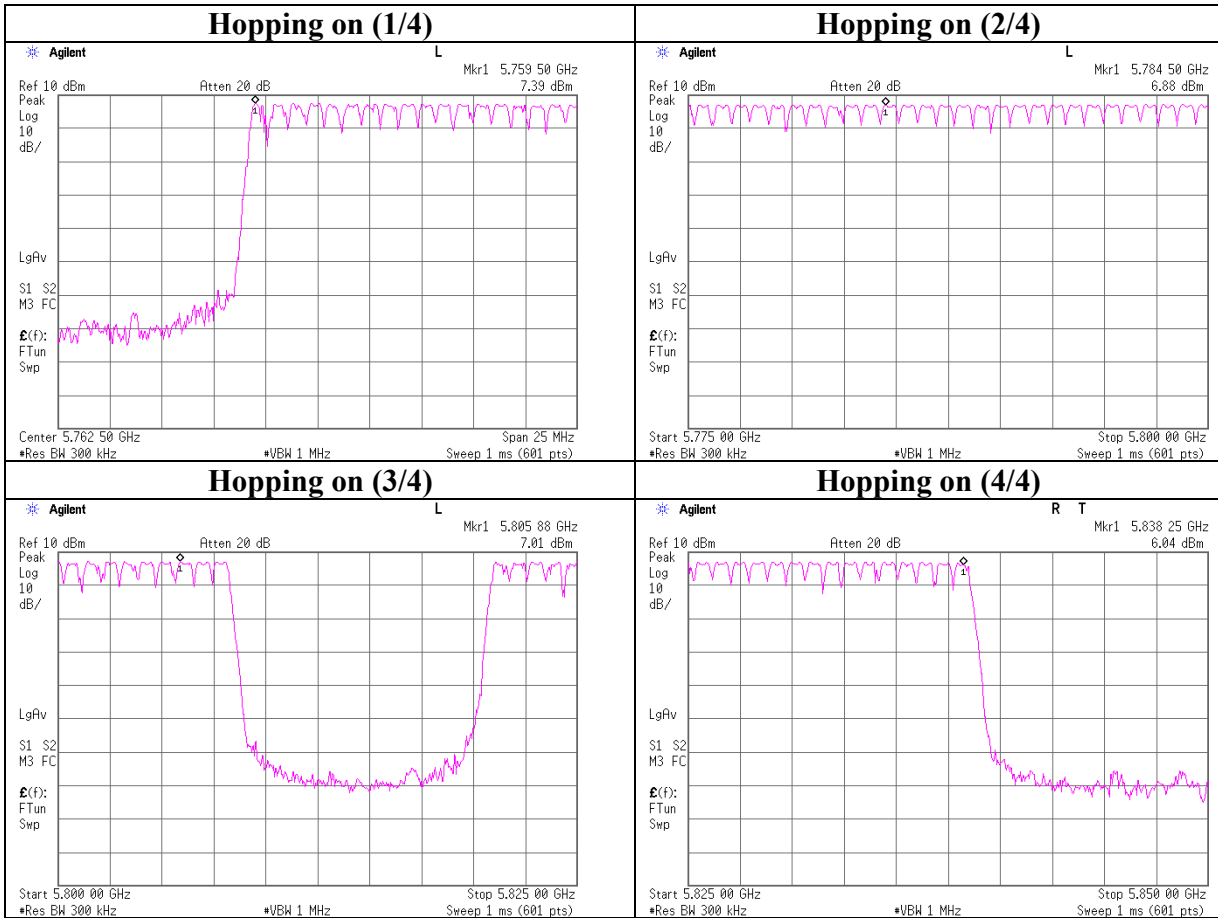

Dwell time

UL Apex Co., Ltd.
Head Office EMC Lab. No.3 Shielded Room

COMPANY : Panasonic Communications Co.,Ltd. REGULATION : FCC Part15 Subpart C 15.247(a)(1)
EQUIPMENT : Cordless Telephone (Baset) TEST DISTANCE : -
MODEL : KX-TG5631 DATE : 10/27/2005
S/ N : 2 TEMPERATURE : 23deg.C
POWER : AC 120 V / 60Hz HUMIDITY : 43%
MODE : Tx(Hopping on) ENGINEER : Kenichi Adachi

Mode	Number of transmission in a 30sec	Length of transmission time [msec]	Result [msec]	Limit [msec]
Tx Hopping on	64 times / 30 sec. x 30 = 64 times	0.973	62	400

Dwell time

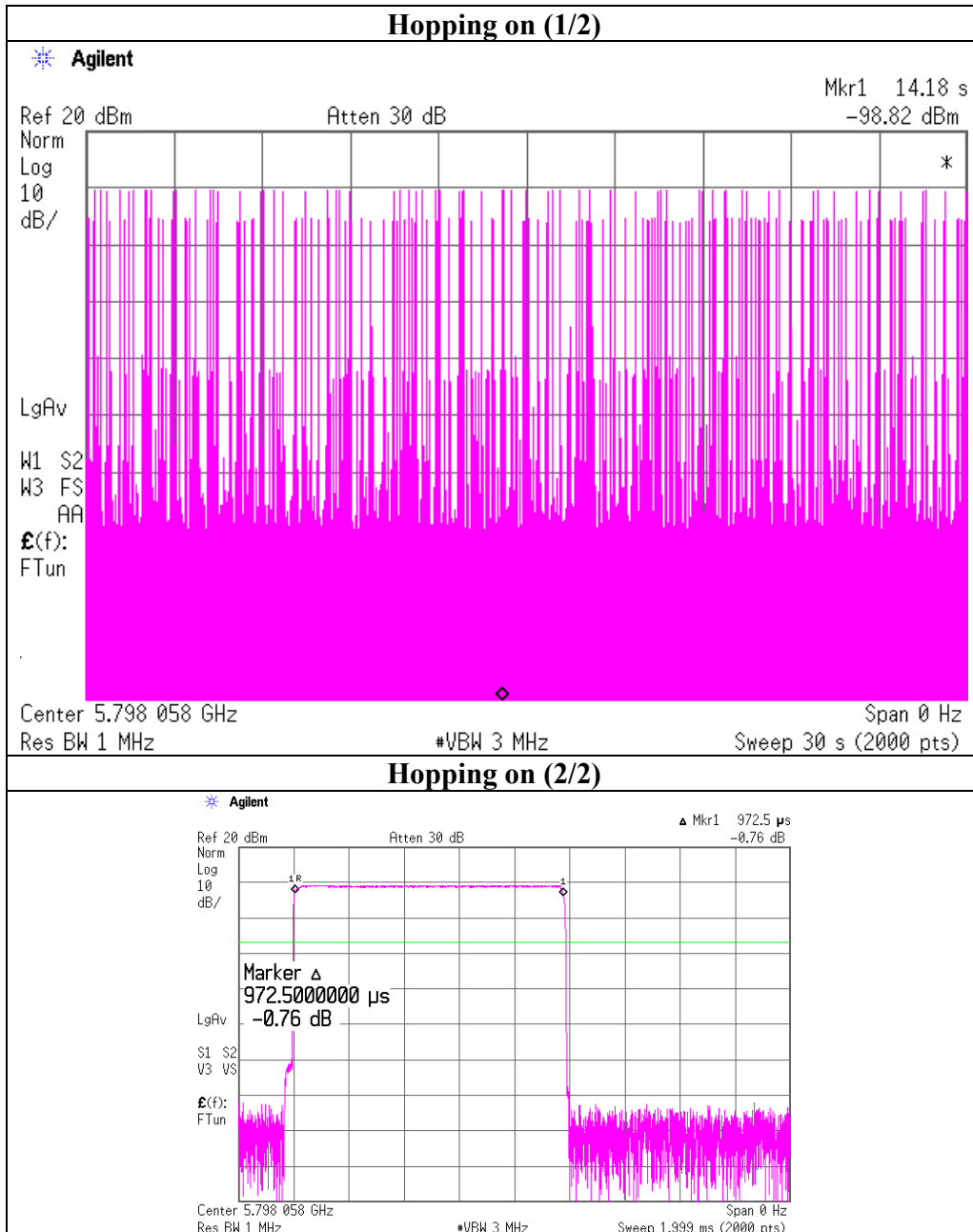

Maximum Peak Output Power

UL Apex Co., Ltd.
Head Office EMC Lab. No.3 Shielded Room

COMPANY : Panasonic Communications Co.,Ltd. REGULATION : FCC Part15 Subpart C 15.247(b)(1)
EQUIPMENT : Cordless Telephone (Baset) TEST DISTANCE : -
MODEL : KX-TG5631 DATE : 10/24/2005
S/N : 2 TEMPERATURE : 23deg.C
POWER : AC 120 V / 60Hz HUMIDITY : 43%
MODE : Tx(Hopping off) ENGINEER : Kenichi Adachi

Left-antenna

Ch	Freq. [MHz]	S/A Reading [dBm]	Cable Loss [dB]	Atten. [dB]	Result [dBm]	Limit [dBm]	Margin [dB]
Low	5759.7	7.43	2.90	9.77	20.10	30.00	9.90
Mid	5798.1	7.05	2.91	9.78	19.74	30.00	10.26
High	5838.2	6.76	2.92	9.79	19.47	30.00	10.53

Right-antenna

Ch	Freq. [MHz]	S/A Reading [dBm]	Cable Loss [dB]	Atten. [dB]	Result [dBm]	Limit [dBm]	Margin [dB]
Low	5759.7	6.15	2.90	9.77	18.82	30.00	11.18
Mid	5798.1	5.75	2.91	9.78	18.44	30.00	11.56
High	5838.2	5.45	2.92	9.79	18.16	30.00	11.84

Sample Calculation:

Result = Reading + Cable Loss (supplied by customer)+ Attenuator

* In the above table, factor 0.0dB represents no use of Atten. and/or Filter.

UL Apex Co., Ltd.

Head Office EMC Lab.

4383-326 Asama-cho, Ise-shi, Mie-ken 516-0021 JAPAN

Telephone : +81 596 24 8116

Facsimile : +81 596 24 8124

MF060b(01.06.05)

Maximum Peak Output Power
Left-antenna

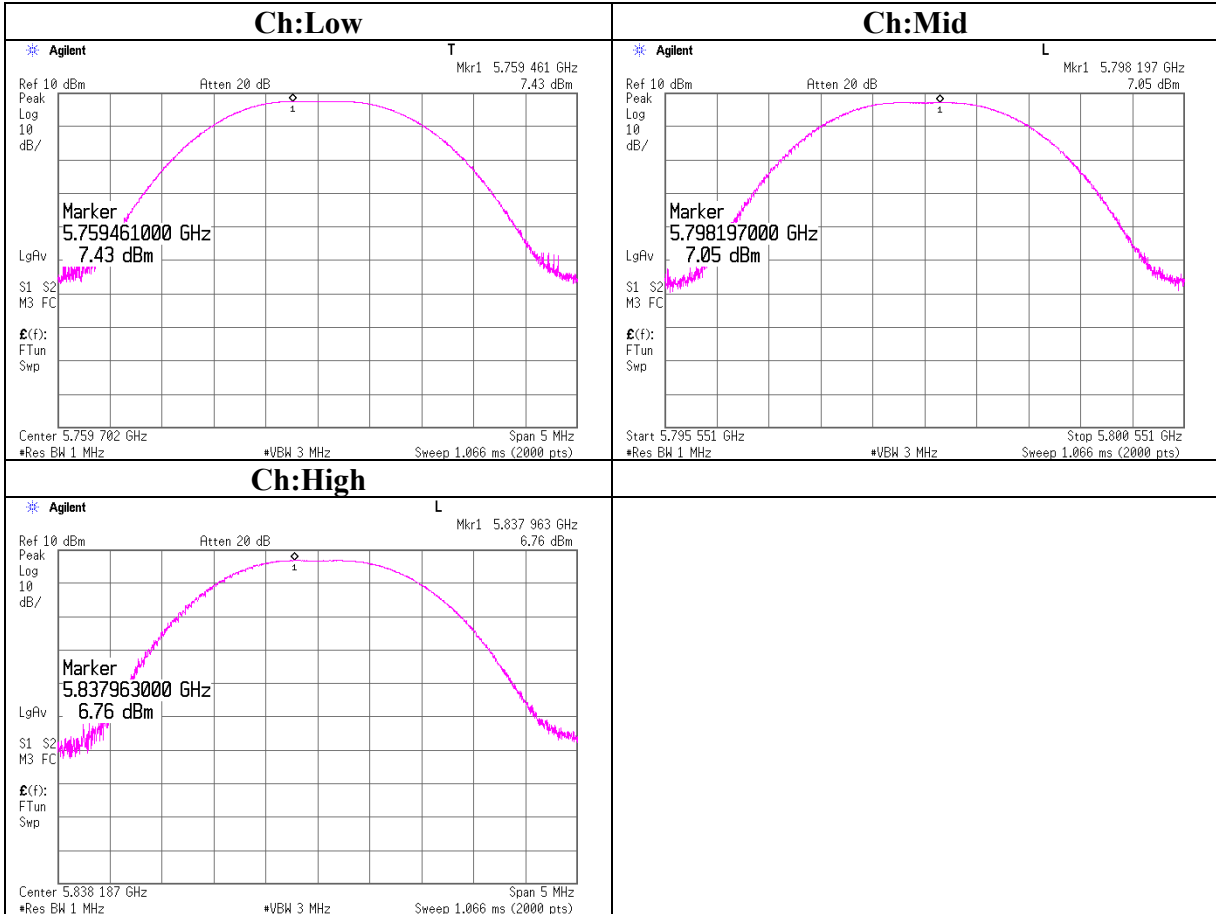

Maximum Peak Output Power
Right-antenna

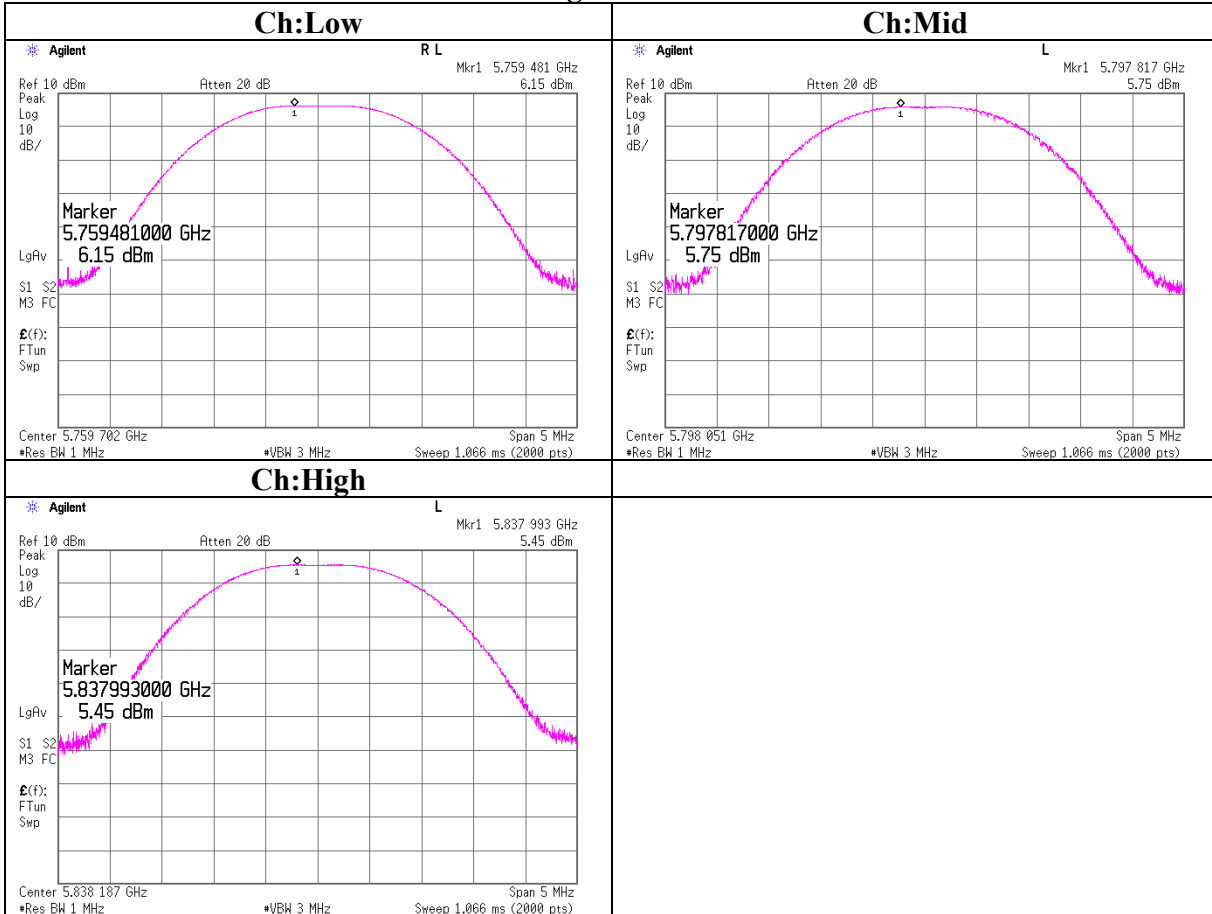

Radiated Spurious Emission
(Tx Low)

* The result is rounded off to the second decimal place. Therefore, there may be 0.1 difference for the result.

DATA OF RADIATED EMISSION TEST

UL Apex Co., Ltd. Head Office EMC Lab. No.2 Semi Anechoic Chamber
Date : 2005/10/26 13:18:31

Applicant : Panasonic Communications Co.,Ltd. Report No. : 26CE0011-HO
Kind of EUT : Cordless Telephone (Basaset) Power : AC 120V / 60Hz
Model No. : KX-TG5631 Temp./Humi. : 24deg. C / 44%
Serial No. : 1 Operator : Kenichi Adachi

Mode / Remarks : Tx5759.70240MHz /EUT-axis: H:X, V:Y(Max-axis)/Ant: Left(Worst)/Ant-axis: H:0deg., V:0deg. (Wors)

LIMIT : FCC15C §15.247(d) 3m, below1GHz:QP, above1GHz:AV / RSS-Gen / RSS-210
Except for the data below : adequate margin data below the limits.

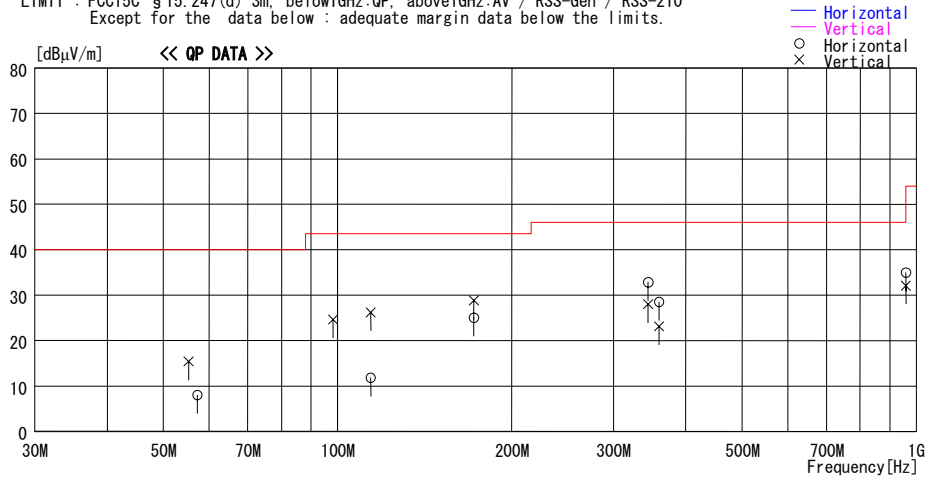

Frequency [MHz]	Reading [dBuV]	DET	Antenna	Loss&	Level	Angle	Height	Polar.	Limit	Margin
			Factor	Gain					[dBuV/m]	[dB]
			[dB/m]	[dB]	[dBuV/m]	[Deg]	[cm]		[dBuV/m]	[dB]
57.239	21.9	QP	8.7	-22.6	8.0	153	190	Hori.	40.0	32.0
55.297	28.9	QP	9.1	-22.6	15.4	85	100	Vert.	40.0	24.6
98.297	37.1	QP	9.6	-22.1	24.6	292	100	Vert.	43.5	18.9
114.092	21.9	QP	11.8	-21.9	11.8	267	300	Hori.	43.5	31.7
114.092	36.3	QP	11.8	-21.9	26.2	292	100	Vert.	43.5	17.3
172.033	34.1	QP	15.7	-21.0	28.8	275	100	Vert.	43.5	14.7
172.035	30.3	QP	15.7	-21.0	25.0	134	160	Hori.	43.5	18.5
344.064	36.7	QP	15.9	-19.8	32.8	0	100	Hori.	46.0	13.2
344.066	31.9	QP	15.9	-19.8	28.0	156	132	Vert.	46.0	18.0
359.425	26.8	QP	16.4	-20.1	23.1	0	145	Vert.	46.0	22.9
359.425	32.2	QP	16.4	-20.1	28.5	0	100	Hori.	46.0	17.5
959.470	26.8	QP	22.7	-17.4	32.1	337	111	Vert.	46.0	13.9
959.662	29.6	QP	22.7	-17.4	34.9	275	151	Hori.	46.0	11.1

CHART: WITH FACTOR ANT TYPE : -30MHz LOOP, 30-300MHz BICONICAL, 300MHz-1000MHz LOGPERIODIC, 1000MHz- HORN
CALCULATION : READING + ANT FACTOR + LOSS (CABLE+ATTEN.) - AMP. GAIN

Radiated Spurious Emission
(Tx Mid)

* The result is rounded off to the second decimal place. Therefore, there may be 0.1 difference for the result.

DATA OF RADIATED EMISSION TEST

UL Apex Co., Ltd. Head Office EMC Lab. No.2 Semi Anechoic Chamber
Date : 2005/10/26 14:26:42

Applicant : Panasonic Communications Co.,Ltd. Report No. : 26CE0011-HO
Kind of EUT : Cordless Telephone (Basetset) Power : AC 120V / 60Hz
Model No. : KX-TG5631 Temp./Humi. : 24deg. C / 44%
Serial No. : 1 Operator : Kenichi Adachi

Mode / Remarks : Tx5798.05084MHz /EUT-axis: H:X,V:Y(Max-axis)/Ant: Left(Worst)/Ant-axis: H:0deg.,V:0deg.(Wors)

LIMIT : FCC15C §15.247(d) 3m, below1GHz:QP, above1GHz:AV / RSS-Gen / RSS-210
Except for the data below : adequate margin data below the limits.

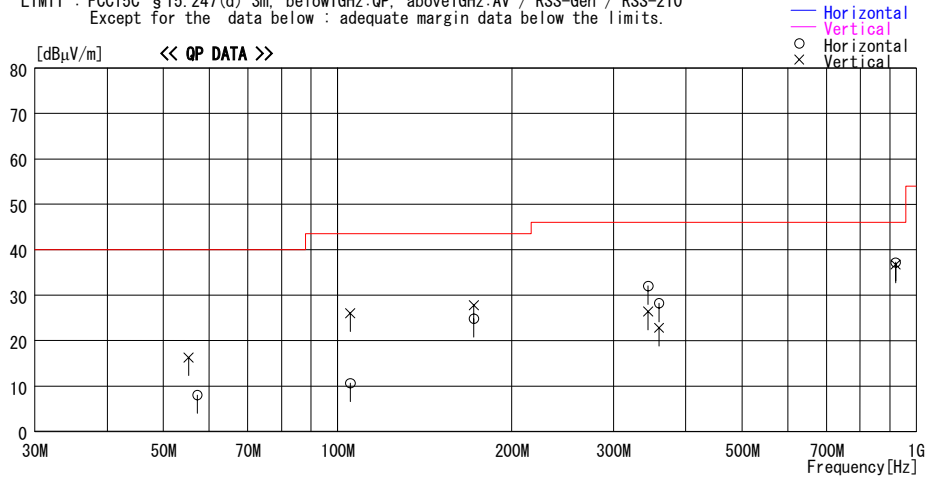

Frequency [MHz]	Reading [dBuV]	DET	Antenna	Loss&	Level	Angle	Height	Polar.	Limit	Margin
			Factor	Gain					[dBuV/m]	[dB]
[MHz]	[dBuV]		[dB/m]	[dB]	[dBuV/m]	[Deg]	[cm]		[dBuV/m]	[dB]
57.238	21.9	QP	8.7	-22.6	8.0	154	180	Hori.	40.0	32.0
55.298	29.8	QP	9.1	-22.6	16.3	138	100	Vert.	40.0	23.7
105.230	37.3	QP	10.6	-21.9	26.0	312	100	Vert.	43.5	17.5
105.230	21.9	QP	10.6	-21.9	10.6	270	250	Hori.	43.5	32.9
172.034	30.1	QP	15.7	-21.0	24.8	124	160	Hori.	43.5	18.7
172.031	33.1	QP	15.7	-21.0	27.8	297	100	Vert.	43.5	15.7
344.065	35.9	QP	15.9	-19.8	32.0	0	100	Hori.	46.0	14.0
344.064	30.3	QP	15.9	-19.8	26.4	151	132	Vert.	46.0	19.6
359.426	31.9	QP	16.4	-20.1	28.2	0	100	Hori.	46.0	17.8
359.423	26.5	QP	16.4	-20.1	22.8	283	100	Vert.	46.0	23.2
921.303	32.5	QP	21.5	-17.3	36.7	0	116	Vert.	46.0	9.3
921.303	33.0	QP	21.5	-17.3	37.2	245	100	Hori.	46.0	8.8

CHART: WITH FACTOR ANT TYPE : -30MHz LOOP, 30-300MHz BICONICAL, 300MHz-1000MHz LOGPERIODIC, 1000MHz- HORN
CALCULATION : READING + ANT FACTOR + LOSS (CABLE+ATTEN.) - AMP. GAIN

**Radiated Spurious Emission
(Tx High)**

* The result is rounded off to the second decimal place. Therefore, there may be 0.1 difference for the result.

DATA OF RADIATED EMISSION TEST

UL Apex Co., Ltd. Head Office EMC Lab. No.2 Semi Anechoic Chamber
Date : 2005/10/26 15:12:58

Applicant : Panasonic Communications Co.,Ltd. Report No. : 26CE0011-HO
Kind of EUT : Cordless Telephone (Basetset) Power : AC 120V / 60Hz
Model No. : KX-TG5631 Temp./Humi. : 24deg. C / 44%
Serial No. : 1 Operator : Kenichi Adachi

Mode / Remarks : Tx5838.18697MHz /EUT-axis: H:X,V:Y(Max-axis)/Ant: Left(Worst)/Ant-axis: H:0deg.,V:0deg.(Wors)

LIMIT : FCC15C §15.247(d) 3m, below1GHz:QP, above1GHz:AV / RSS-Gen / RSS-210
Except for the data below : adequate margin data below the limits.

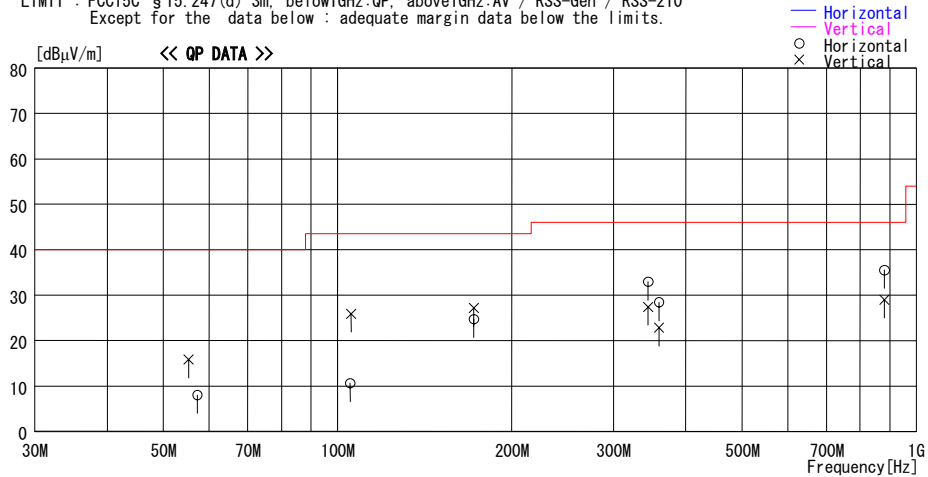

Frequency [MHz]	Reading [dBµV]	DET	Antenna	Loss&	Level	Angle	Height	Polar.	Limit	Margin
			Factor	Gain						
			[dB/m]	[dB]	[dBµV/m]	[Deg]	[cm]		[dBµV/m]	[dB]
55.296	29.3	QP	9.1	-22.6	15.8	336	100	Vert.	40.0	24.2
57.240	21.9	QP	8.7	-22.6	8.0	180	155	Hori.	40.0	32.0
105.150	21.9	QP	10.6	-21.9	10.6	268	256	Hori.	43.5	32.9
105.600	37.1	QP	10.7	-21.9	25.9	315	100	Vert.	43.5	17.6
172.034	30.0	QP	15.7	-21.0	24.7	131	158	Hori.	43.5	18.8
172.033	32.5	QP	15.7	-21.0	27.2	285	100	Vert.	43.5	16.3
344.063	36.8	QP	15.9	-19.8	32.9	0	100	Hori.	46.0	13.1
344.065	31.3	QP	15.9	-19.8	27.4	134	153	Vert.	46.0	18.6
359.425	32.1	QP	16.4	-20.1	28.4	0	100	Hori.	46.0	17.6
359.426	26.5	QP	16.4	-20.1	22.8	278	100	Vert.	46.0	23.2
881.179	32.4	QP	20.9	-17.8	35.5	254	100	Hori.	46.0	10.5
881.157	25.9	QP	20.9	-17.8	29.0	346	111	Vert.	46.0	17.0

CHART: WITH FACTOR ANT TYPE : -30MHz LOOP, 30-300MHz BICONICAL, 300MHz-1000MHz LOGPERIODIC, 1000MHz- HORN
CALCULATION : READING + ANT FACTOR + LOSS (CABLE+ATTEN.) - AMP. GAIN

Radiated Spurious Emission (Tx Low)

UL Apex Co., Ltd.
Head Office EMC Lab. No.1 and No.2 Semi Anechoic Chamber

Company : Panasonic Communications Co.,Ltd.	REPORT NO : 26CE0011-HO
Equipment : Cordless Telephone (Basetet)	REGULATION : FCC Part15 Subpart C 15.247(d)
Model : KX-TG5631	TEST DISTANCE : 3m/1m/0.5m
Sample No. : 1	DATE : 10/23/2005 : 10/25/2005
Power : AC120V / 60Hz	TEMPERATURE : 23deg.C : 23deg.C
Mode : Tx 5759.70240MHz	HUMIDITY : 40% : 40%
Remarks : Hor : X-axis / Ver : Y-axis	ENGINEER : Kenichi Adachi : Yutaka Yoshida

PK DETECT (RBW: 1MHz, VBW: 1MHz)

No.	FREQ [MHz]	S/A READING		ANT Factor [dB/m]	AMP GAIN [dB]	CABLE LOSS [dB]	Band-Pass Filter [dB]	RESULT		Limit PK [dBuV/m]	MARGIN	
		HOR [dBuV]	VER [dBuV]					HOR [dBuV/m]	VER [dBuV/m]		HOR [dB]	VER [dB]
Test distance 3meters RESULT=Reading + ANT Factor - Amp Gain + Cable Loss + Filter Loss												
1	1788.8	61.4	61.2	28.4	40.7	2.9	0.0	52.0	51.8	74.0	22.0	22.2
2	2400.3	56.1	58.6	30.9	41.2	3.1	0.0	48.9	51.4	74.0	25.1	22.6
3	4668.5	62.6	62.0	34.2	42.4	4.2	0.0	58.6	58.0	74.0	15.4	16.0
4	5279.3	68.5	67.4	35.9	42.6	4.4	0.0	66.2	65.1	74.0	7.8	8.9
5	5433.2	57.0	56.5	35.8	42.6	4.6	0.0	54.8	54.3	74.0	19.2	19.7
6	5725.0	52.2	52.2	36.1	42.7	4.6	0.0	50.2	50.2	74.0	23.8	23.8
7	6240.0	67.7	66.1	36.6	42.5	4.8	0.0	66.6	65.0	74.0	7.4	9.0
8	11519.7	55.1	57.2	38.4	40.3	7.0	0.2	60.4	62.5	74.0	13.6	11.5
9*	17279.6	52.9	55.6	44.4	42.0	8.5	4.7	68.5	71.2	74.0	-	-
Test distance 1meters RESULT=Reading + ANT Factor - Amp Gain + Cable Loss + Filter Loss - Dfac												
10	23038.0	51.6	54.7	40.8	39.5	9.3	0.0	52.7	55.8	74.0	21.3	18.2
Test distance 0.5meters RESULT=Reading + ANT Factor - Amp Gain + Cable Loss + Filter Loss - Dfac												
11	28798.5	36.3	37.4	41.3	24.3	15.3	0.0	53.0	54.1	74.0	21.0	19.9
12	34558.2	39.6	40.2	42.2	24.6	17.1	0.0	58.7	59.3	74.0	15.3	14.7

AV DETECT (RBW: 1MHz, VBW: 10Hz)

No.	FREQ [MHz]	S/A READING		ANT Factor [dB/m]	AMP GAIN [dB]	CABLE LOSS [dB]	Band-Pass Filter [dB]	RESULT		Limit AV [dBuV/m]	MARGIN	
		HOR [dBuV]	VER [dBuV]					HOR [dBuV/m]	VER [dBuV/m]		HOR [dB]	VER [dB]
Test distance 3meters RESULT=Reading + ANT Factor - Amp Gain + Cable Loss + Filter Loss												
1	1788.8	41.6	41.7	28.4	40.7	2.9	0.0	32.2	32.3	54.0	21.8	21.7
2	2400.3	40.9	41.4	30.9	41.2	3.1	0.0	33.7	34.2	54.0	20.3	19.8
3	4668.5	42.1	41.8	34.2	42.4	4.2	0.0	38.1	37.8	54.0	15.9	16.2
4	5279.3	43.2	42.9	35.9	42.6	4.4	0.0	40.9	40.6	54.0	13.1	13.4
5	5433.2	40.5	40.2	35.8	42.6	4.6	0.0	38.3	38.0	54.0	15.7	16.0
6	5725.0	38.0	37.9	36.1	42.7	4.6	0.0	36.0	35.9	54.0	18.0	18.1
7	6240.0	40.8	40.7	36.6	42.5	4.8	0.0	39.7	39.6	54.0	14.3	14.4
8	11519.7	36.5	38.5	38.4	40.3	7.0	0.2	41.8	43.8	54.0	12.2	10.2
9*	17279.6	35.7	38.4	44.4	42.0	8.5	4.7	51.3	54.0	54.0	-	-
Test distance 1meters RESULT=Reading + ANT Factor - Amp Gain + Cable Loss + Filter Loss - Dfac												
10	23038.0	33.8	34.9	40.8	39.5	9.3	0.0	34.9	36.0	54.0	19.1	18.0
Test distance 0.5meters RESULT=Reading + ANT Factor - Amp Gain + Cable Loss + Filter Loss - Dfac												
11	28798.5	22.2	22.8	41.3	24.3	15.3	0.0	38.9	39.5	54.0	15.1	14.5
12	34558.2	27.3	27.5	42.2	24.6	17.1	0.0	46.4	46.6	54.0	7.6	7.4

* Reference data

20dBc(Fundamental 5759.7MHz) (RBW: 100kHz, VBW: 300kHz)

No.	FREQ [MHz]	S/A READING		ANT Factor [dB/m]	AMP GAIN [dB]	CABLE LOSS [dB]	Band-Pass Filter or ATT [dB]	RESULT		Limit 20dBc [dBuV/m]	MARGIN	
		HOR [dBuV]	VER [dBuV]					HOR [dBuV/m]	VER [dBuV/m]		HOR [dB]	VER [dB]
Test distance 3meters RESULT=Reading + ANT Factor - Amp Gain + Cable Loss + Filter Loss												
0	5759.7	105.1	104.0	36.2	42.7	4.6	20.2	123.4	122.3	-	-	-
9	17279.6	49.9	52.5	44.4	42.0	8.5	4.7	65.5	68.1	Funda-20dB	37.9	34.2

Test Distance 1.0m : Distance Factor(Dfac) = 20log(3/1.0) = 9.5dB

Test Distance 0.5m : Distance Factor(Dfac) = 20log(3/0.5) = 15.6dB

*Except for the above table : All other spurious emissions were less than 20dB for the limit.

*In the frequency over the fifth harmonic, the noise from the EUT was not seen. The data above is its base noise.

*The result is rounded off to the second decimal place. Therefore, there may be 0.1 difference for the result.

*Hi-Pass Filter was not used for factor 0.0dB of the above table.

Radiated Spurious Emission (Tx Mid)

UL Apex Co., Ltd.
Head Office EMC Lab. No.1 and No.2 Semi Anechoic Chamber

Company : Panasonic Communications Co.,Ltd.	REPORT NO : 26CE0011-HO
Equipment : Cordless Telephone (BaseSet)	REGULATION : FCC Part15 Subpart C 15.247(d)
Model : KX-TG5631	TEST DISTANCE : 3m/1m/0.5m
Sample No. : 1	DATE : 10/23/2005 : 10/25/2005
Power : AC120V / 60Hz	TEMPERATURE : 23deg.C : 23deg.C
Mode : Tx 5798.05084MHz	HUMIDITY : 40% : 40%
Remarks : Hor : X-axis / Ver : Y-axis	ENGINEER : Kenichi Adachi : Yutaka Yoshida

PK DETECT (RBW: 1MHz, VBW: 1MHz)

No.	FREQ [MHz]	S/A READING		ANT Factor [dB/m]	AMP GAIN [dB]	CABLE LOSS [dB]	Band-Pass Filter [dB]	RESULT		Limit PK [dBuV/m]	MARGIN	
		HOR	VER					HOR	VER		HOR	VER
Test distance 3meters RESULT=Reading + ANT Factor - Amp Gain + Cable Loss + Filter Loss												
1	1510.7	66.7	66.2	23.7	41.0	2.8	0.0	52.2	51.7	74.0	21.8	22.3
2	1827.1	60.6	60.4	29.0	40.6	3.0	0.0	52.0	51.8	74.0	22.0	22.2
3	2438.2	60.4	58.9	30.9	41.2	3.2	0.0	53.3	51.8	74.0	20.7	22.2
4	4726.7	62.2	62.3	34.5	42.5	4.3	0.0	58.5	58.6	74.0	15.5	15.4
5	5202.8	64.9	60.2	35.9	42.5	4.4	0.0	62.7	58.0	74.0	11.3	16.0
6	5529.0	62.3	62.3	35.8	42.6	4.6	0.0	60.1	60.1	74.0	13.9	13.9
7	6066.8	61.7	60.2	36.5	42.6	4.7	0.0	60.3	58.8	74.0	13.7	15.2
8	11595.6	55.0	60.8	38.9	40.3	7.0	0.2	60.8	66.6	74.0	13.2	7.4
9*	17394.9	53.2	52.3	44.4	42.0	8.6	5.5	69.7	68.8	74.0	-	-
Test distance 1meters RESULT=Reading + ANT Factor - Amp Gain + Cable Loss + Filter Loss - Dfac												
10	23191.4	51.4	55.2	40.8	39.4	9.3	0.0	52.6	56.4	74.0	21.4	17.6
Test distance 0.5meters RESULT=Reading + ANT Factor - Amp Gain + Cable Loss + Filter Loss - Dfac												
11	28990.3	35.9	39.1	41.3	24.4	15.4	0.0	52.6	55.8	74.0	21.4	18.2
12	34788.3	43.0	40.2	42.1	24.5	17.2	0.0	62.2	59.4	74.0	11.8	14.6

AV DETECT (RBW: 1MHz, VBW: 10Hz)

No.	FREQ [MHz]	S/A READING		ANT Factor [dB/m]	AMP GAIN [dB]	CABLE LOSS [dB]	Band-Pass Filter [dB]	RESULT		Limit AV [dBuV/m]	MARGIN	
		HOR	VER					HOR	VER		HOR	VER
Test distance 3meters RESULT=Reading + ANT Factor - Amp Gain + Cable Loss + Filter Loss												
1	1510.7	42.6	42.6	23.7	41.0	2.8	0.0	28.1	28.1	54.0	25.9	25.9
2	1827.1	42.7	41.3	29.0	40.6	3.0	0.0	34.1	32.7	54.0	19.9	21.3
3	2438.2	42.9	41.5	30.9	41.2	3.2	0.0	35.8	34.4	54.0	18.2	19.6
4	4726.7	42.2	42.2	34.5	42.5	4.3	0.0	38.5	38.5	54.0	15.5	15.5
5	5202.8	42.3	39.8	35.9	42.5	4.4	0.0	40.1	37.6	54.0	13.9	16.4
6	5529.0	40.3	40.3	35.8	42.6	4.6	0.0	38.1	38.1	54.0	15.9	15.9
7	6066.8	41.3	40.0	36.5	42.6	4.7	0.0	39.9	38.6	54.0	14.1	15.4
8	11595.6	38.2	40.2	38.9	40.3	7.0	0.2	44.0	46.0	54.0	10.0	8.0
9*	17394.9	37.0	36.5	44.4	42.0	8.6	5.5	53.5	53.0	54.0	-	-
Test distance 1meters RESULT=Reading + ANT Factor - Amp Gain + Cable Loss + Filter Loss - Dfac												
10	23191.4	33.9	35.3	40.8	39.4	9.3	0.0	35.1	36.5	54.0	18.9	17.5
Test distance 0.5meters RESULT=Reading + ANT Factor - Amp Gain + Cable Loss + Filter Loss - Dfac												
11	28990.3	21.8	22.9	41.3	24.4	15.4	0.0	38.5	39.6	54.0	15.5	14.4
12	34788.3	28.4	27.7	42.1	24.5	17.2	0.0	47.6	46.9	54.0	6.4	7.1

* Reference data

20dBc(Fundamental 5798.1MHz) (RBW: 100kHz, VBW: 300kHz)

No.	FREQ [MHz]	S/A READING		ANT Factor [dB/m]	AMP GAIN [dB]	CABLE LOSS [dB]	Band-Pass Filter or AT	RESULT		Limit 20dBc [dBuV/m]	MARGIN	
		HOR	VER					HOR	VER		HOR	VER
Test distance 3meters RESULT=Reading + ANT Factor - Amp Gain + Cable Loss + Filter Loss												
0	5798.1	105.9	104.2	36.2	42.7	4.6	20.2	124.2	122.5	-	-	-
9	17278.4	47.9	46.1	44.4	42.0	8.6	5.5	64.4	62.6	Funda-20dB	39.8	39.9

Test Distance 1.0m : Distance Factor(Dfac) = 20log(3/1.0) = 9.5dB

Test Distance 0.5m : Distance Factor(Dfac) = 20log(3/0.5) = 15.6dB

*Except for the above table : All other spurious emissions were less than 20dB for the limit.

*In the frequency over the fifth harmonic, the noise from the EUT was not seen. The data above is its base noise.

*The result is rounded off to the second decimal place. Therefore, there may be 0.1 difference for the result.

*Hi-Pass Fiter was not used for factor 0.0dB of the above table.

Radiated Spurious Emission (Tx High)

UL Apex Co., Ltd.

Head Office EMC Lab. No.1 and No.2 Semi Anechoic Chamber

Company : Panasonic Communications Co.,Ltd.	REPORT NO : 26CE0011-HO
Equipment : Cordless Telephone (BaseSet)	REGULATION : FCC Part15 Subpart C 15.247(d)
Model : KX-TG5631	TEST DISTANCE : 3m/1m/0.5m
Sample No. : 1	DATE : 10/23/2005 : 10/25/2005
Power : AC120V / 60Hz	TEMPERATURE : 23deg.C : 23deg.C
Mode : Tx 5838.18697MHz	HUMIDITY : 40% : 40%
Remarks : Hor : X-axis / Ver : Y-axis	ENGINEER : Kenichi Adachi : Yutaka Yoshida

PK DETECT (RBW: 1MHz, VBW: 1MHz)

No.	FREQ [MHz]	S/A READING		ANT Factor [dB/m]	AMP GAIN [dB]	CABLE LOSS [dB]	Band-Pass Filter [dB]	RESULT		Limit PK [dBuV/m]	MARGIN	
		HOR	VER					HOR	VER		HOR	VER
Test distance 3meters RESULT=Reading + ANT Factor - Amp Gain + Cable Loss + Filter Loss												
1	1633.6	58.0	58.3	25.9	40.8	2.8	0.0	45.9	46.2	74.0	28.1	27.8
2	1868.6	57.6	58.1	29.6	40.6	3.0	0.0	49.6	50.1	74.0	24.4	23.9
3	2479.4	58.5	58.8	30.8	41.3	3.1	0.0	51.1	51.4	74.0	22.9	22.6
4	4959.0	59.6	60.8	35.8	42.5	4.3	0.0	57.2	58.4	74.0	16.8	15.6
5	5676.6	59.7	63.9	36.1	42.6	4.6	0.0	57.8	62.0	74.0	16.2	12.0
6	5850.0	48.9	49.0	36.3	42.7	4.6	0.0	47.1	47.2	74.0	26.9	26.8
7	6719.4	55.7	55.3	37.0	42.0	5.0	0.0	55.7	55.3	74.0	18.3	18.7
8	11677.8	56.6	62.4	39.4	40.3	7.0	0.3	63.0	68.8	74.0	11.0	5.2
9*	17516.4	52.8	53.7	44.3	42.1	8.7	6.3	70.0	70.9	74.0	-	-
Test distance 1meters RESULT=Reading + ANT Factor - Amp Gain + Cable Loss + Filter Loss - Dfac												
10	23357.2	50.7	54.1	40.8	39.3	9.3	0.0	52.0	55.4	74.0	22.0	18.6
Test distance 0.5meters RESULT=Reading + ANT Factor - Amp Gain + Cable Loss + Filter Loss - Dfac												
11	29190.9	34.9	37.9	41.3	24.4	15.5	0.0	51.7	54.7	74.0	22.3	19.3
12	35029.1	40.6	40.2	42.1	24.4	17.2	0.0	59.9	59.5	74.0	14.1	14.5

AV DETECT (RBW: 1MHz, VBW: 10Hz)

No.	FREQ [MHz]	S/A READING		ANT Factor [dB/m]	AMP GAIN [dB]	CABLE LOSS [dB]	Band-Pass Filter [dB]	RESULT		Limit AV [dBuV/m]	MARGIN	
		HOR	VER					HOR	VER		HOR	VER
Test distance 3meters RESULT=Reading + ANT Factor - Amp Gain + Cable Loss + Filter Loss												
1	1633.6	40.1	40.5	25.9	40.8	2.8	0.0	28.0	28.4	54.0	26.0	25.6
2	1868.6	40.0	40.4	29.6	40.6	3.0	0.0	32.0	32.4	54.0	22.0	21.6
3	2479.4	41.0	41.7	30.8	41.3	3.1	0.0	33.6	34.3	54.0	20.4	19.7
4	4959.0	40.9	41.8	35.8	42.5	4.3	0.0	38.5	39.4	54.0	15.5	14.6
5	5676.6	39.9	40.5	36.1	42.6	4.6	0.0	38.0	38.6	54.0	16.0	15.4
6	5850.0	35.5	35.4	36.3	42.7	4.6	0.0	33.7	33.6	54.0	20.3	20.4
7	6719.4	40.0	40.5	37.0	42.0	5.0	0.0	40.0	40.5	54.0	14.0	13.5
8	11677.8	39.4	41.7	39.4	40.3	7.0	0.3	45.8	48.1	54.0	8.2	5.9
9*	17516.4	36.7	37.2	44.3	42.1	8.7	6.3	53.9	54.4	54.0	-	-
Test distance 1meters RESULT=Reading + ANT Factor - Amp Gain + Cable Loss + Filter Loss - Dfac												
10	23357.2	33.7	34.7	40.8	39.3	9.3	0.0	35.0	36.0	54.0	19.0	18.0
Test distance 0.5meters RESULT=Reading + ANT Factor - Amp Gain + Cable Loss + Filter Loss - Dfac												
11	29190.9	21.8	22.2	41.3	24.4	15.5	0.0	38.6	39.0	54.0	15.4	15.0
12	35029.1	28.4	28.7	42.1	24.4	17.2	0.0	47.7	48.0	54.0	6.3	6.0

* Reference data

20dBc(Fundamental 5838.2MHz) (RBW: 100kHz, VBW: 300kHz)

No.	FREQ [MHz]	S/A READING		ANT Factor [dB/m]	AMP GAIN [dB]	CABLE LOSS [dB]	Band-Pass Filter or AT [dB]	RESULT		Limit 20dBc [dBuV/m]	MARGIN	
		HOR	VER					HOR	VER		HOR	VER
Test distance 3meters RESULT=Reading + ANT Factor - Amp Gain + Cable Loss + Filter Loss												
0	5838.2	105.6	104.1	36.3	42.7	4.6	20.2	124.0	122.5	-	-	-
9	17516.7	45.9	48.8	44.3	42.1	8.7	6.2	63.0	65.9	Funda-20dB	41.0	36.6

Test Distance 1.0m : Distance Factor(Dfac) = 20log(3/1.0) = 9.5dB

Test Distance 0.5m : Distance Factor(Dfac) = 20log(3/0.5) = 15.6dB

*Except for the above table : All other spurious emissions were less than 20dB for the limit.

*In the frequency over the fifth harmonic, the noise from the EUT was not seen. The data above is its base noise.

*The result is rounded off to the second decimal place. Therefore, there may be 0.1 difference for the result.

*Hi-Pass Fiter was not used for factor 0.0dB of the above table.

Conducted Spurious Emission

Ch:Low

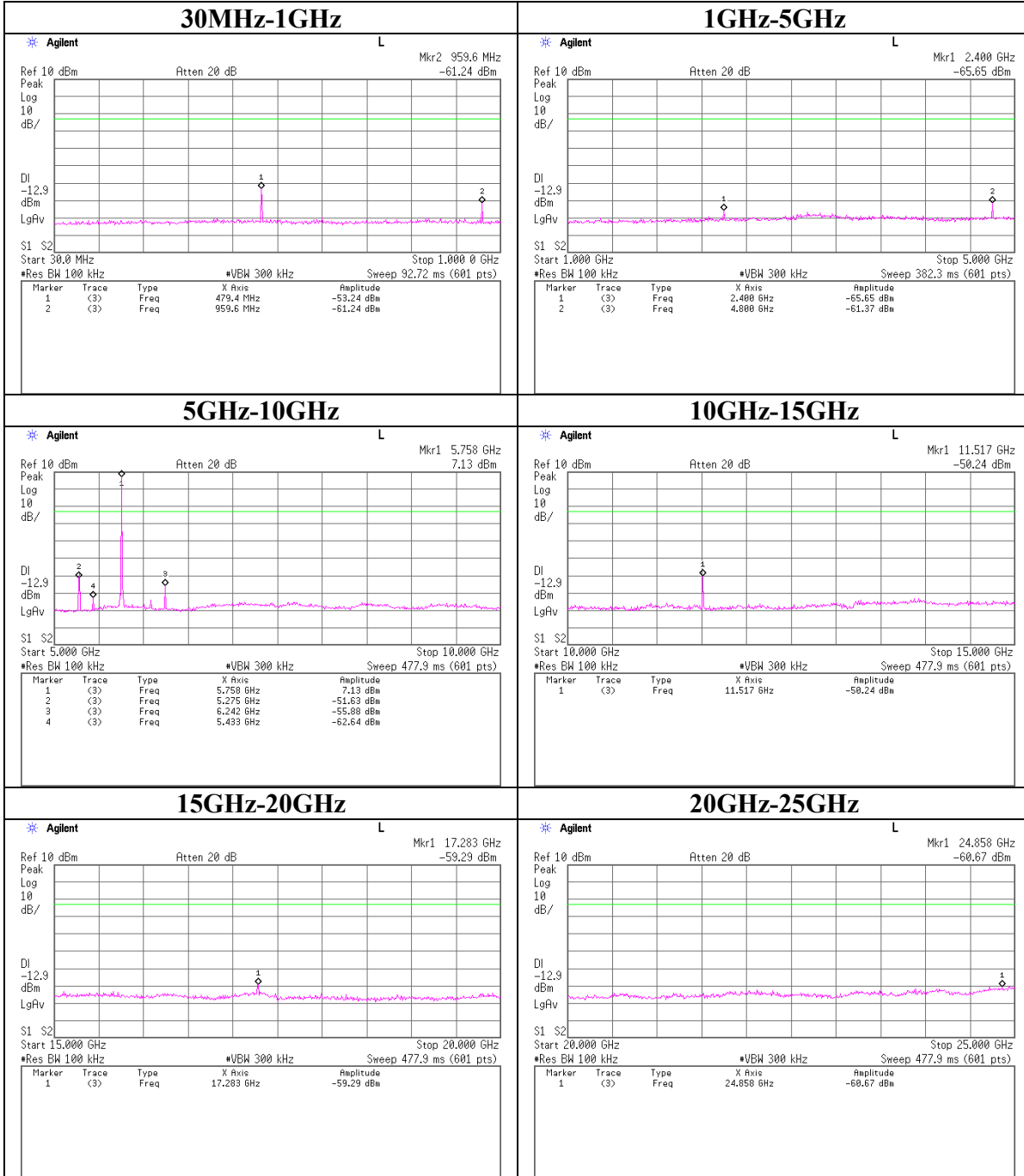

Conducted Spurious Emission
Ch:Low

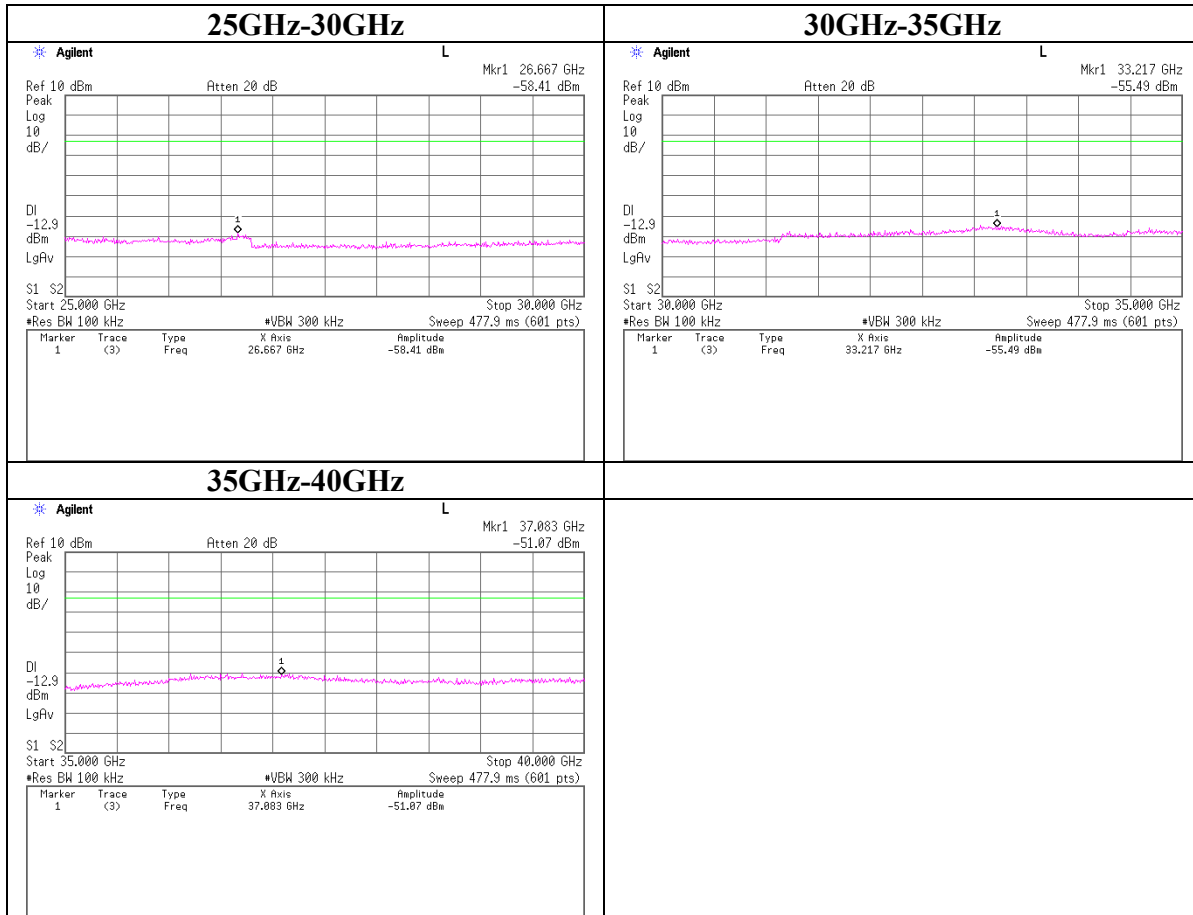

Conducted Spurious Emission
Ch:Mid

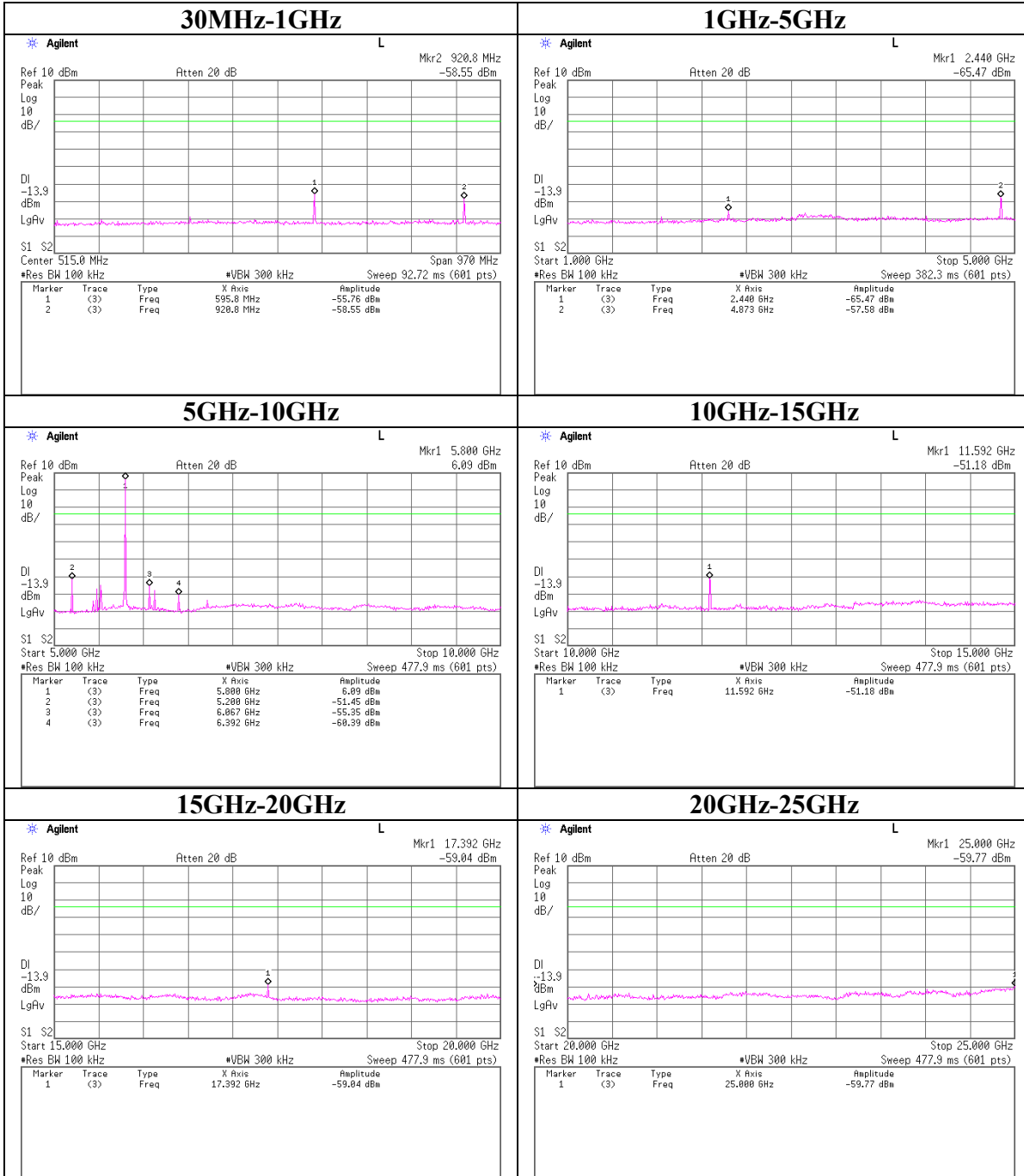

Conducted Spurious Emission
Ch:Mid

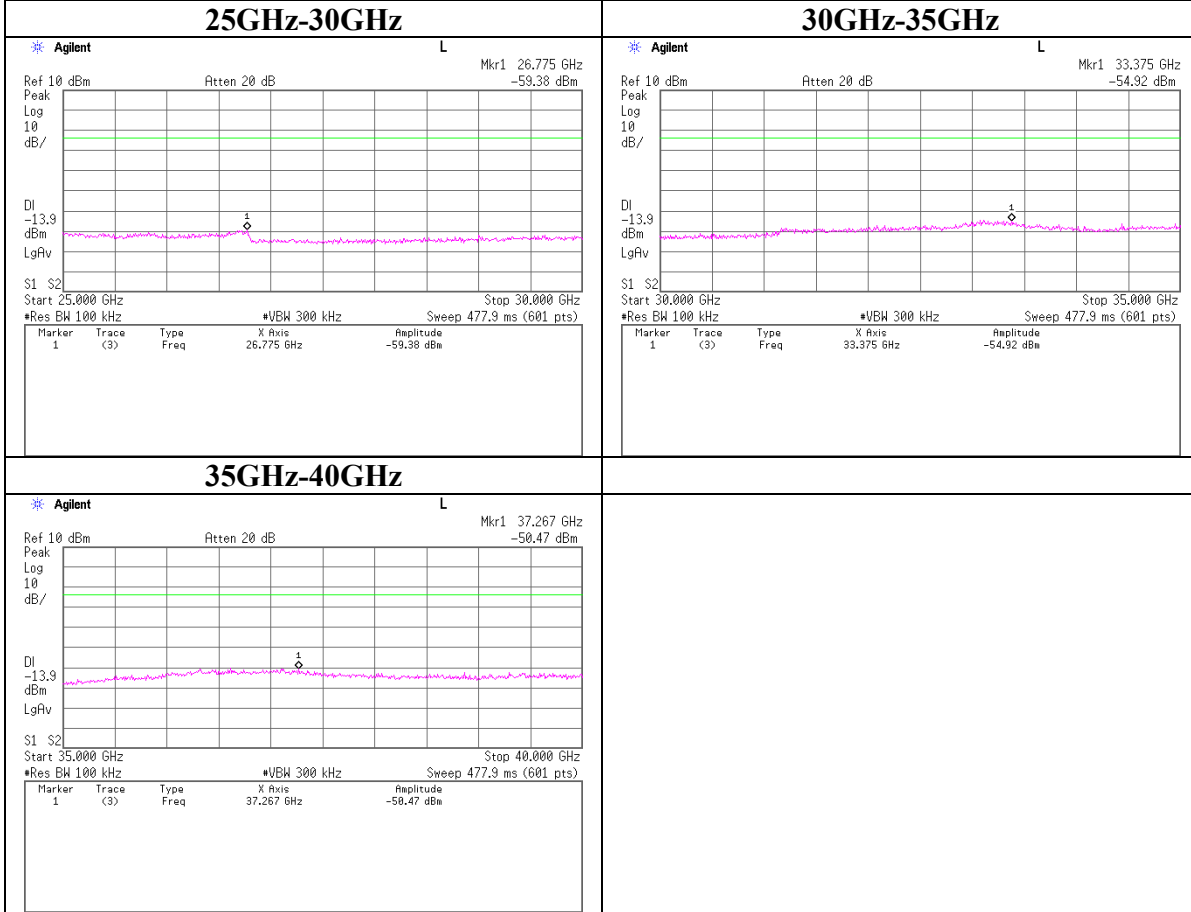

Conducted Spurious Emission
Ch:High

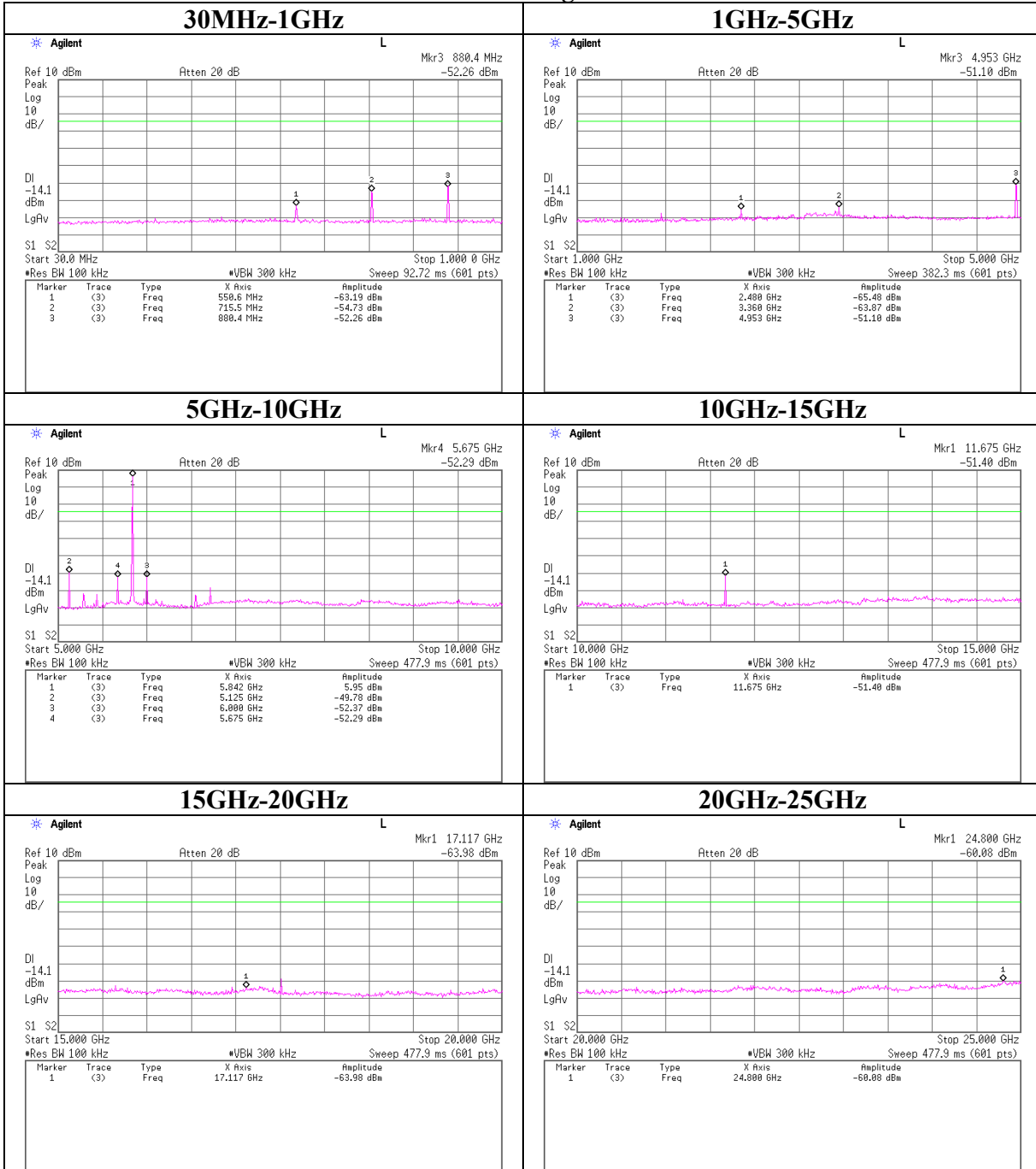

Conducted Spurious Emission
Ch:High

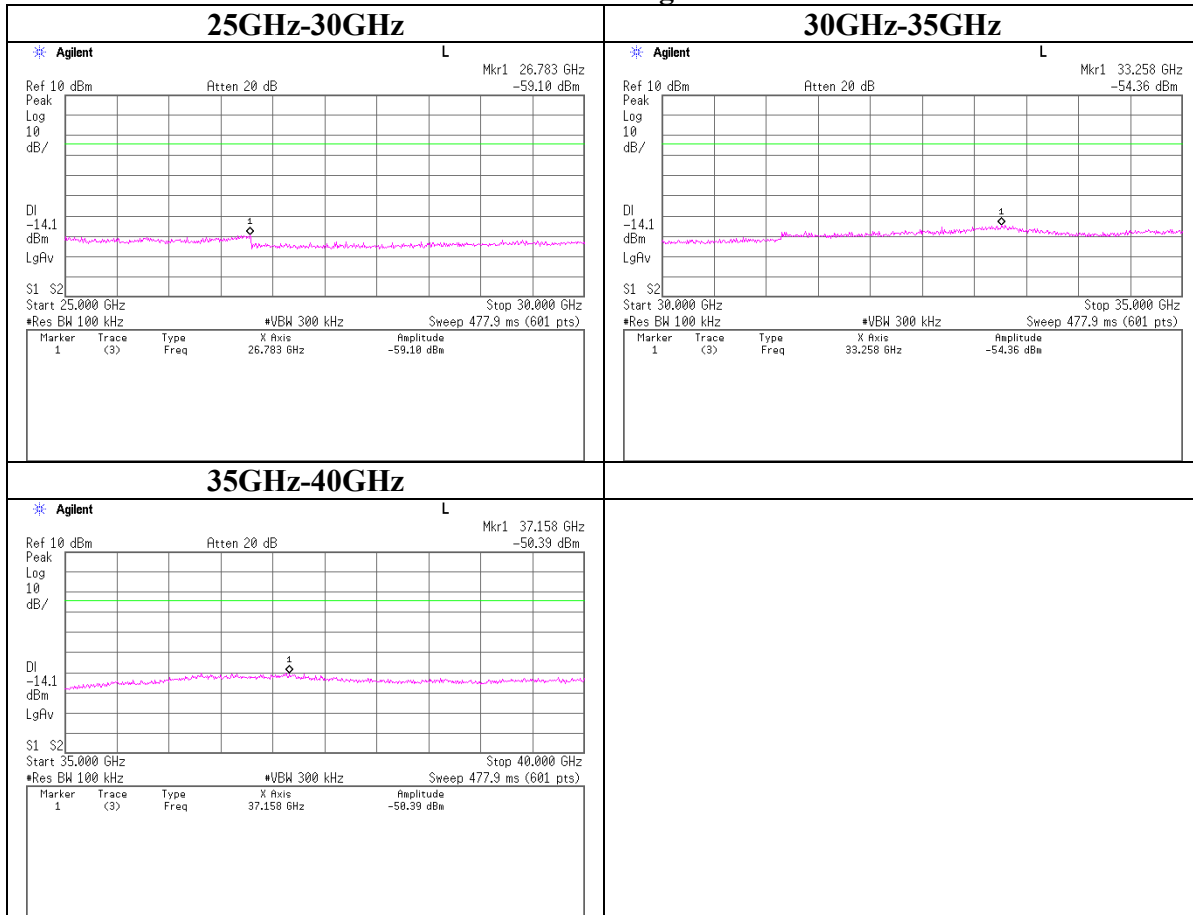

Conducted Spurious Emission Band Edge compliance

