



# RADIO TEST REPORT

Test Report No. : 28BE0083-HO-B

Applicant : Panasonic Communications Co., Ltd.  
Type of Equipment : Cordless Telephone (Base)  
Model No. : KX-TG4321  
FCC ID : ACJ96NKX-TG4321  
Test standard : FCC Part 15 Subpart C 2007  
Section 15.207, Section 15.247  
Test Result : Complied

1. This test report shall not be reproduced in full or partial, without the written approval of UL Japan, Inc.
2. The results in this report apply only to the sample tested.
3. This equipment is in compliance with the above regulation.
4. The test results in this report are traceable to the national or international standards.

Date of test:

October 1 to 10, 2007

Tested by:

*T. Sasagawa*

Tomotaka Sasagawa  
EMC Services

*M. Kosaka*

Makoto Kosaka  
EMC Services

Approved by :

*H. Shimoji*

Hironobu Shimoji  
Assistant Manager of EMC Services



NVLAP LAB CODE: 200572-0

This laboratory is accredited by the NVLAP LAB CODE 200572-0, U.S.A. The tests reported herein have been performed in accordance with its terms of accreditation.  
\*As for the range of Accreditation in NVLAP, you may refer to the WEB address, <http://ulapex.jp/emc/nvlap.htm>

UL Japan, Inc.

Head Office EMC Lab.

4383-326 Asama-cho, Ise-shi, Mie-ken 516-0021 JAPAN

Telephone : +81 596 24 8116

Facsimile : +81 596 24 8124

MF060b (18.06.07)

<b>CONTENTS</b>	<b>PAGE</b>
<b>SECTION 1: Client information</b> .....	<b>3</b>
<b>SECTION 2: Equipment under test (E.U.T.)</b> .....	<b>3</b>
<b>SECTION 3: Test specification, procedures &amp; results</b> .....	<b>4</b>
<b>SECTION 4: Operation of E.U.T. during testing</b> .....	<b>8</b>
<b>SECTION 5: Conducted Emission</b> .....	<b>10</b>
<b>SECTION 6: Spurious Emission</b> .....	<b>11</b>
<b>SECTION 7: Bandwidth</b> .....	<b>12</b>
<b>SECTION 8: Maximum Peak Output Power</b> .....	<b>12</b>
<b>SECTION 9: Carrier Frequency Separation</b> .....	<b>12</b>
<b>SECTION 10: Number of Hopping Frequency</b> .....	<b>12</b>
<b>SECTION 11: Dwell time</b> .....	<b>12</b>
<b>APPENDIX 1: Photographs of test setup</b> .....	<b>13</b>
Conducted Emission.....	13
Spurious Emission (Radiated).....	15
<b>APPENDIX 2: Data of EMI test</b> .....	<b>16</b>
Conducted Emission.....	16
Carrier Frequency Separation.....	28
20dB Bandwidth.....	30
Number of Hopping Frequency.....	32
Dwell time.....	34
Maximum Peak Output Power.....	36
Radiated Spurious Emission (below 1GHz).....	37
Radiated Spurious Emission (above 1GHz).....	41
Conducted Spurious Emission.....	45
99% Occupied Bandwidth.....	53
<b>APPENDIX 3: Test instruments</b> .....	<b>54</b>

## **SECTION 1: Client information**

Company Name	Panasonic Communications Co., Ltd.
Brand name	Panasonic
Address	1-62, 4-chome, Minoshima, Hakata-ku, Fukuoka, 812-8531 Japan
Telephone Number	+81-92-477-1405
Facsimile Number	+81-92-477-1487
Contact Person	Kunihiko Nawata

## **SECTION 2: Equipment under test (E.U.T.)**

### **2.1 Identification of E.U.T.**

Type of Equipment	Cordless Telephone (Base)
Model No.	KX-TG4321
Serial No.	RF TEST No.1 (Used for Antenna Terminal Conducted test) Air001 (Used for Conducted Emission and Radiated Emission tests)
Rating	AC120V, 60Hz (AC adapter: PQLV207, DC6.5V)
Country of Manufacture	China
Condition of EUT	Engineering prototype (Not for sale: This sample is equivalent to mass-produced items.)
Receipt Date of Sample	October 1, 2007
Modification of EUT	No modification by the test lab.

### **2.2 Product Description**

Equipment Type	Transceiver
Frequency band	Lower Channel : 5759.700MHz Upper Channel : 5838.185MHz
Bandwidth & Channel spacing	Bandwidth: 79MHz Channel spacing: 892kHz
Type of Modulation	FHSS
Antenna Type	Collinear-Antenna
Antenna Gain	3dBi Typ.
Power Supply (RF Part)	DC4.0V
Method of Frequency Generation	Synthesizer
Operation Clock	Main clock 13.824 MHz

---

**UL Japan, Inc.**

**Head Office EMC Lab.**

4383-326 Asama-cho, Ise-shi, Mie-ken 516-0021 JAPAN

Telephone : +81 596 24 8116

Facsimile : +81 596 24 8124

### **SECTION 3: Test specification, procedures & results**

#### **3.1 Test Specification**

Test Specification : FCC Part15 Subpart C: 2007  
Title : FCC 47CFR Part15 Radio Frequency Device Subpart C Intentional Radiators  
Section 15.207 Conducted limits  
Section 15.247 Operation within the bands 902-928MHz,  
2400-2483.5MHz, and 5725-5850MHz

#### **FCC 15.31 (e)**

The EUT provides stable voltage (DC4V) constantly to RF Module regardless of input voltage. Therefore, the EUT complies with the requirement.

#### **FCC Part 15.203 Antenna requirement**

It is impossible for end users to replace the antenna, because the antenna is mounted inside of the EUT. Therefore, the equipment complies with the antenna requirement of Section 15.203.

---

**UL Japan, Inc.**

**Head Office EMC Lab.**

4383-326 Asama-cho, Ise-shi, Mie-ken 516-0021 JAPAN

Telephone : +81 596 24 8116

Facsimile : +81 596 24 8124

3.2 Procedures and results

No.	Item	Test Procedure	Specification	Remarks	Deviation	Worst Margin	Results
1	Conducted emission	FCC: ANSI C63.4:2003 7. AC powerline conducted emission measurements	FCC: Section 15.207	Conducted	N/A	[Tx] 25.7dB 7.83540MHz QP, N [Rx] 26.1dB 7.84893MHz QP, N	Complied
		IC: RSS-Gen 7.2.2	IC: RSS-Gen 7.2.2				
2	Carrier Frequency Separation	FCC: ANSI C63.4:2003 13. Measurement of intentional radiators	FCC: Section 15.247(a)(1)	Conducted	N/A		Complied
		IC: -	IC: RSS-210 A8.1 (b)				
3	20dB Bandwidth	FCC: ANSI C63.4:2003 13. Measurement of intentional radiators	FCC: Section 15.247(a)(1)(ii)	Conducted	N/A		Complied
		IC: -	IC: RSS-210 A8.1 (a) (e)				
4	Number of Hopping Frequency	FCC: ANSI C63.4:2003 13. Measurement of intentional radiators	FCC: Section 15.247(a)(1)(ii)	Conducted	N/A		Complied
		IC: -	IC: RSS-210 A8.1 (e)				
5	Dwell time	FCC: ANSI C63.4:2003 13. Measurement of intentional radiators	FCC: Section 15.247(a)(1)(ii)	Conducted	N/A	See data.	Complied
		IC: -	IC: RSS-210 A8.1 (e)				
6	Maximum Peak Output Power	FCC: ANSI C63.4:2003 13. Measurement of intentional radiators	FCC: Section 15.247(b)(1)	Conducted	N/A		Complied
		IC: RSS-Gen 4.8	IC: RSS-210 A8.4 (3)				
7	Band Edge Compliance	FCC: ANSI C63.4:2003 13. Measurement of intentional radiators	FCC: Section 15.247(d)	Conducted	N/A		Complied
		IC: -	IC: RSS-210 A8.5				
8	Spurious Emission	FCC: ANSI C63.4:2003 13. Measurement of intentional radiators	FCC: Section 15.247(d)	Conducted/ Radiated	N/A	[Tx] 7.1dB 17514.56MHz Horizontal, AV [Rx] 9.2dB 17394.16MHz Horizontal, AV	Complied
		IC: RSS-Gen 4.9 RSS-Gen 4.10	IC: RSS-210 A8.5 RSS-Gen 7.2.1 and 7.2.3				

Note: UL Japan, Inc.'s EMI Work Procedures No.QPM05 and QPM15.

\*These tests were also referred to FCC Public Notice DA 00-705 "Guidance on Measurement for Frequency Hopping Spread Spectrum Systems".

\*These tests were performed without any deviations from test procedure except for additions or exclusions.

### 3.3 Addition to standards

No.	Item	Test Procedure	Specification	Remarks	Deviation	Worst margin	Results
1	99% Occupied Band Width	IC: RSS-Gen 4.6.1	IC: RSS-Gen 4.6.1	Conducted	N/A	N/A	N/A

### 3.4 Uncertainty

The following uncertainties have been calculated to provide a confidence level of 95% using a coverage factor k=2.

#### Conducted Emission

The measurement uncertainty for this test is  $\pm 4.19\text{dB}$ (9-150kHz),  $\pm 3.73\text{dB}$ (150kHz-30MHz).  
The data listed in this test report has enough margin, more than the site margin.

#### Spurious Emission (Radiated)

The measurement uncertainty for this test using Biconical antenna is  $\pm 4.88\text{dB}$ (3m).  
The measurement uncertainty for this test using Logperiodic antenna is  $\pm 4.86\text{dB}$ (3m).  
The measurement uncertainty for this test using Horn antenna is  $\pm 5.77\text{dB}$ .  
The data listed in this test report has enough margin, more than the site margin.

#### Other test except Conducted Emission and Spurious Emission (Radiated)

The measurement uncertainty for this test is  $\pm 3.0\text{dB}$ .

---

**UL Japan, Inc.**

**Head Office EMC Lab.**

4383-326 Asama-cho, Ise-shi, Mie-ken 516-0021 JAPAN

Telephone : +81 596 24 8116

Facsimile : +81 596 24 8124

### 3.5 Test Location

UL Japan, Inc. Head Office EMC Lab. \*NVLAP Lab. code: 200572-0  
4383-326 Asama-cho, Ise-shi, Mie-ken 516-0021 JAPAN  
Telephone: +81 596 24 8116 Facsimile: +81 596 24 8124

	FCC Registration Number	IC Registration Number	Width x Depth x Height (m)	Size of reference ground plane (m) / horizontal conducting plane	Other rooms
No.1 semi-anechoic chamber	313583	IC4247	19.2 x 11.2 x 7.7m	7.0 x 6.0m	No.1 Power source room
No.2 semi-anechoic chamber	655103	IC4247-2	7.5 x 5.8 x 5.2m	4.0 x 4.0m	-
No.3 semi-anechoic chamber	148738	IC4247-3	12.0 x 8.5 x 5.9m	6.8 x 5.75m	No.3 Preparation room
No.3 shielded room	-	-	4.0 x 6.0 x 2.7m	N/A	-
No.4 semi-anechoic chamber	134570	IC4247-4	12.0 x 8.5 x 5.9m	6.8 x 5.75m	No.4 Preparation room
No.4 shielded room	-	-	4.0 x 6.0 x 2.7m	N/A	-
No.5 semi-anechoic chamber	-	-	6.0 x 6.0 x 3.9m	6.0 x 6.0m	-
No.6 shielded room	-	-	4.0 x 4.5 x 2.7m	4.75 x 5.4 m	-
No.6 measurement room	-	-	4.75 x 5.4 x 3.0m	4.75 x 4.15 m	-
No.7 shielded room	-	-	4.7 x 7.5 x 2.7m	4.7 x 7.5m	-
No.8 measurement room	-	-	3.1 x 5.0 x 2.7m	N/A	-

\* Size of vertical conducting plane (for Conducted Emission test) : 2.0 x 2.0m for No.1, No.2, No.3, and No.4 semi-anechoic chambers and No.3 and No.4 shielded rooms.

### 3.6 Test set up, Test instruments and Data of EMI

Refer to APPENDIX 1 to 3.

## **SECTION 4: Operation of E.U.T. during testing**

### **4.1 Operating Modes**

<b>Test</b>	<b>Operating mode</b>	<b>Tested frequency</b>
Carrier Frequency Separation	Transmitting (Tx) (Hopping on)	5759.700MHz 5798.053MHz 5838.185MHz
Conducted Emission	Transmitting (Tx), Charged Transmitting (Tx), Non-Charged	5759.700MHz 5798.053MHz 5838.185MHz
	Receiving (Rx), Charged Receiving (Rx), Non-Charged	5798.053MHz
Maximum Peak Output Power 20dB Bandwidth	Transmitting (Tx) (Hopping off)	5759.700MHz 5798.053MHz 5838.185MHz
Number of Hopping Frequency Dwell time	Transmitting (Tx) (Hopping on)	-
Spurious Emission (Radiated/Conducted)	Transmitting (Tx)	5759.700MHz 5798.053MHz 5838.185MHz
	Receiving (Rx)	5798.053MHz
Band Edge compliance(Conducted)	Transmitting (Tx) Hopping on	-
	Transmitting (Tx) Hopping off	5759.700MHz 5838.185MHz
99% Occupied Bandwidth	Transmitting (Tx) Hopping on	-
	Transmitting (Tx) Hopping off	5759.700MHz 5798.053MHz 5838.185MHz

#### **[Remarks]**

The EUT has 2 antennas (Antenna 1 and 2). The Antenna 1 is used for Spurious Emission test since Antenna 1 has the higher output power level than Antenna 2. As for Conducted Emission test, both Antenna 1 and 2 were used.

**UL Japan, Inc.**

**Head Office EMC Lab.**

4383-326 Asama-cho, Ise-shi, Mie-ken 516-0021 JAPAN

Telephone : +81 596 24 8116

Facsimile : +81 596 24 8124

#### 4.2 Configuration and peripherals

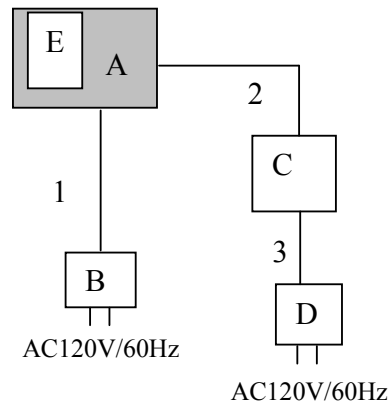

\* Cabling and setup were taken into consideration and test data was taken under worse case conditions.

#### Description of EUT and Support equipment

No.	Item	Model number	Serial number	Manufacturer	Remark
A	Cordless Telephone (Base)	KX-TG4321	RF TEST No.1 *1) Air001 *2)	Panasonic Communications Co., Ltd.	EUT
B	AC Adapter	PQLV207	0639E	Panasonic Communications Co., Ltd.	-
C	DATA FAX MODEM	LFM-288BS	56L10220306	Logitec	-
D	AC Adapter	AM-128100AT	61-16557	AMIGO	-
E	Cordless Telephone (Handset) *3)	KX-TGA431	Air001	Panasonic Communications Co., Ltd.	-

#### List of cables used

No.	Name	Length (m)	Shield	
			Cable	Connector
1	DC Cable	2.0	Unshielded	Unshielded
2	Telephone cable	1.0	Unshielded	Unshielded
3	DC Cable	1.9	Unshielded	Unshielded

\*1) Used for Antenna Terminal Conducted test

\*2) Used for Conducted Emission and Radiated Emission tests

\*3) Used for Conducted Emission (with Handset battery-charged) test only

**UL Japan, Inc.**

**Head Office EMC Lab.**

4383-326 Asama-cho, Ise-shi, Mie-ken 516-0021 JAPAN

Telephone : +81 596 24 8116

Facsimile : +81 596 24 8124

## **SECTION 5: Conducted Emission**

### **Test Procedure and conditions**

EUT was placed on a urethane platform of nominal size, 1.0m by 1.5m, raised 80cm above the conducting ground plane. The rear of tabletop was located 40cm to the vertical conducting plane. The rear of EUT, including peripherals aligned and flushed with rear of tabletop. All other surfaces of tabletop were at least 80cm from any other grounded conducting surface. EUT was located 80cm from a Line Impedance Stabilization Network (LISN)/ Artificial mains Network (AMN) and excess AC cable was bundled in center.

#### For the tests on EUT with other peripherals (as a whole system)

I/O cable and AC cables that were connected to the peripherals were bundled in center. They were folded back and forth forming a bundle 30cm to 40cm long and were hanged at a 40cm height to the ground plane. All unused 50ohm connectors of the LISN(AMN) were resistivity terminated in 50ohm when not connected to the measuring equipment.

The AC Mains Terminal Continuous disturbance Voltage has been measured with the EUT in a Semi Anechoic Chamber or a Measurement Room.

The EUT was connected to a LISN (AMN).

An overview sweep with peak detection has been performed.

<b>Detector</b>	<b>: CISPR quasi-peak and average detector (IF BW 9 kHz)</b>
<b>Measurement range</b>	<b>: 0.15-30MHz</b>
<b>Test data</b>	<b>: APPENDIX 2</b>
<b>Test result</b>	<b>: Pass</b>

---

**UL Japan, Inc.**

**Head Office EMC Lab.**

4383-326 Asama-cho, Ise-shi, Mie-ken 516-0021 JAPAN

Telephone : +81 596 24 8116

Facsimile : +81 596 24 8124

## **SECTION 6: Spurious Emission**

### **[Conducted]**

#### **Test Procedure**

The Out of Band Emission was measured with a spectrum analyzer connected to the antenna port.

**Test data** : APPENDIX 2

**Test result** : Pass

### **[Radiated]**

#### **Test Procedure**

EUT was placed on a urethane platform of nominal size, 1.0m by 1.5m, raised 80cm above the conducting ground plane.

The Radiated Electric Field Strength intensity has been measured in a Semi Anechoic Chamber with a ground plane and at a distance of 3m(Below 10GHz) and 1m(Upper 10GHz).

The height of the measuring varied between 1 and 4m and EUT was rotated a full revolution in order to obtain the maximum value of the electric field intensity.

The measurements were performed for both vertical and horizontal antenna polarization with the Test Receiver, or the Spectrum Analyzer (in linear mode).

The test was made with the detector (RBW/VBW) in the following table.

When using Spectrum analyzer, the test was made with adjusting span to zero by using peak hold.

The result also satisfied with the general limits specified in section 15.209(a).

Frequency	Below 1GHz	Above 1GHz
Instrument used	Test Receiver	Spectrum Analyzer
Detector	QP: BW 120kHz	PK: RBW:1MHz/VBW: 1MHz
IF Bandwidth		AV: RBW:1MHz/VBW:10Hz

- The test was made on EUT at the normal use position.

**Test data** : APPENDIX 2

**Test result** : Pass

---

**UL Japan, Inc.**

**Head Office EMC Lab.**

4383-326 Asama-cho, Ise-shi, Mie-ken 516-0021 JAPAN

Telephone : +81 596 24 8116

Facsimile : +81 596 24 8124

## **SECTION 7: Bandwidth**

### **Test Procedure**

The bandwidth was measured with a spectrum analyzer connected to the antenna port.

Test data : APPENDIX 2  
Test result : Pass

## **SECTION 8: Maximum Peak Output Power**

### **Test Procedure**

The Maximum Peak Output Power was measured with a power meter (tested bandwidth: 50MHz) connected to the antenna port.

Test data : APPENDIX 2  
Test result : Pass

## **SECTION 9: Carrier Frequency Separation**

### **Test Procedure**

The carrier frequency separation was measured with a spectrum analyzer connected to the antenna port.

Test data : APPENDIX 2  
Test result : Pass

## **SECTION 10: Number of Hopping Frequency**

### **Test Procedure**

The Number of Hopping Frequency was measured with a spectrum analyzer connected to the antenna port.

Test data : APPENDIX 2  
Test result : Pass

## **SECTION 11: Dwell time**

### **Test Procedure**

The Dwell time was measured with a spectrum analyzer connected to the antenna port.

Test data : APPENDIX 2  
Test result : Pass

---

**UL Japan, Inc.**

**Head Office EMC Lab.**

4383-326 Asama-cho, Ise-shi, Mie-ken 516-0021 JAPAN

Telephone : +81 596 24 8116

Facsimile : +81 596 24 8124

**APPENDIX 1: Photographs of test setup**

**Conducted Emission**  
(Charged)

This page has been submitted in a separate sheet.

**Conducted Emission**  
(Non-Charged)

This page has been submitted in a separate sheet.

**Spurious Emission (Radiated)**

This page has been submitted in a separate sheet.

**APPENDIX 2: Data of EMI test**

**Conducted Emission**  
 (Charged Tx, Ant1, Low)

**DATA OF CONDUCTED EMISSION TEST**

UL Japan, Inc. Head Office EMC Lab. No. 3 Semi Anechoic Chamber  
Date : 2007/10/03

Company : Panasonic Communications  
 Kind of EUT : Cordless Telephone (Base)  
 Model No. : KX-TG4321  
 Serial No. : Air001  
 Report No. : 28BE0083-HO  
 Power : AC 120V / 60Hz  
 Temp./Humi. : 24 deg. C. / 64%  
 Operator : Tomotaka Sasagawa

Mode / Remarks : Transmitting, Lch, 5759.7MHz, ANT1

LIMIT : FCC15.207 QP  
FCC15.207 AV

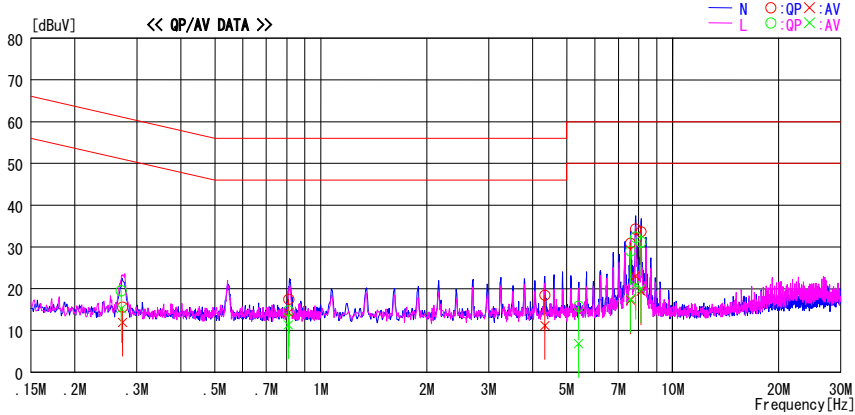

Frequency [MHz]	Reading Level		Corr. Factor [dB]	Results		Limit		Margin		Phase	Comment
	QP [dBuV]	AV [dBuV]		QP [dBuV]	AV [dBuV]	QP [dBuV]	AV [dBuV]	QP [dB]	AV [dB]		
0.27310	15.3	11.6	0.3	15.6	11.9	61.0	51.0	45.4	39.1	N	
0.81110	17.2	14.0	0.3	17.5	14.3	56.0	46.0	38.5	31.7	N	
4.33350	17.7	10.5	0.7	18.4	11.2	56.0	46.0	37.6	34.8	N	
7.58740	29.9	16.3	1.0	30.9	17.3	60.0	50.0	29.1	32.7	N	
7.83540	33.3	22.0	1.0	34.3	23.0	60.0	50.0	25.7	27.0	N	
8.12919	32.6	18.4	1.0	33.6	19.4	60.0	50.0	26.4	30.6	N	
0.27120	19.2	14.9	0.3	19.5	15.2	61.1	51.1	41.6	35.9	L	
0.80914	14.4	11.0	0.3	14.7	11.3	56.0	46.0	41.3	34.7	L	
5.40415	15.0	6.0	0.8	15.8	6.8	60.0	50.0	44.2	43.2	L	
8.12664	30.2	19.0	1.0	31.2	20.0	60.0	50.0	28.8	30.0	L	
7.83570	31.3	19.8	1.0	32.3	20.8	60.0	50.0	27.7	29.2	L	
7.58520	28.0	16.6	1.0	29.0	17.6	60.0	50.0	31.0	32.4	L	

CHART: WITH FACTOR, Peak hold data. CALCULATION: RESULT [dBuV] = READING [dBuV] + C.F [dB] (LISN LOSS + CABLE LOSS)  
Except for the above table: adequate margin data below the limits.

**Conducted Emission**  
 (Charged Tx, Ant2, Low)

**DATA OF CONDUCTED EMISSION TEST**

UL Japan, Inc. Head Office EMC Lab. No.3 Semi Anechoic Chamber  
 Date : 2007/10/03

Company	: Panasonic Communications	Report No.	: 28BE0083-HO
Kind of EUT	: Cordless Telephone (Base)	Power	: AC 120V / 60Hz
Model No.	: KX-TG4321	Temp./Humi.	: 24 deg. C. / 64%
Serial No.	: Air001	Operator	: Tomotaka Sasagawa

Mode / Remarks : Transmitting , Lch , 5759.7MHz ,

LIMIT : FCC15.207 QP  
 FCC15.207 AV

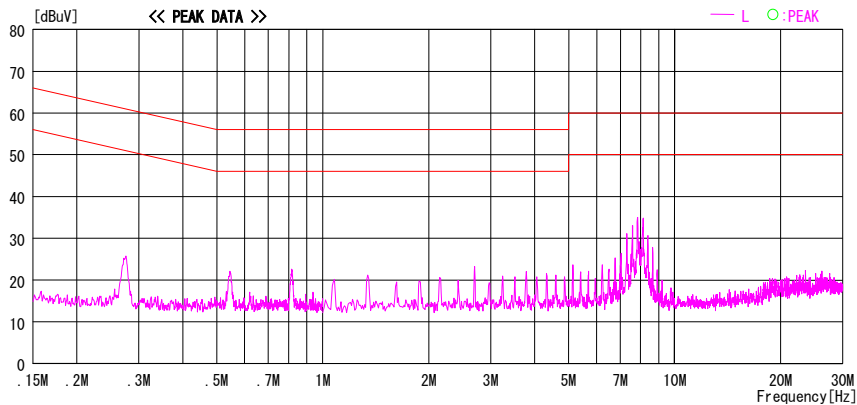
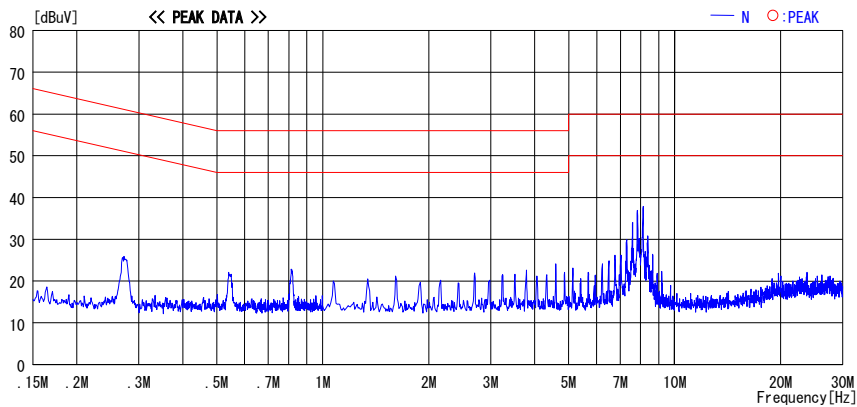

CHART: WITH FACTOR, Peak hold data. CALCULATION: RESULT[dBuV]=READING[dBuV]+C.F[dB] (LISN LOSS+CABLE LOSS)  
 Except for the above table: adequate margin data below the limits.

**Conducted Emission**  
 (Charged Tx, Ant1, Mid)

**DATA OF CONDUCTED EMISSION TEST**

UL Japan, Inc. Head Office EMC Lab. No.3 Semi Anechoic Chamber  
 Date : 2007/10/03

Company	: Panasonic Communications	Report No.	: 28BE0083-HO
Kind of EUT	: Cordless Telephone (Base)	Power	: AC 120V / 60Hz
Model No.	: KX-TG4321	Temp./Humi.	: 24 deg. C. / 64%
Serial No.	: Air001	Operator	: Tomotaka Sasagawa

Mode / Remarks : Transmitting , Mch , 5798.053MHz , ANT1

LIMIT : FCC15.207 QP  
 FCC15.207 AV

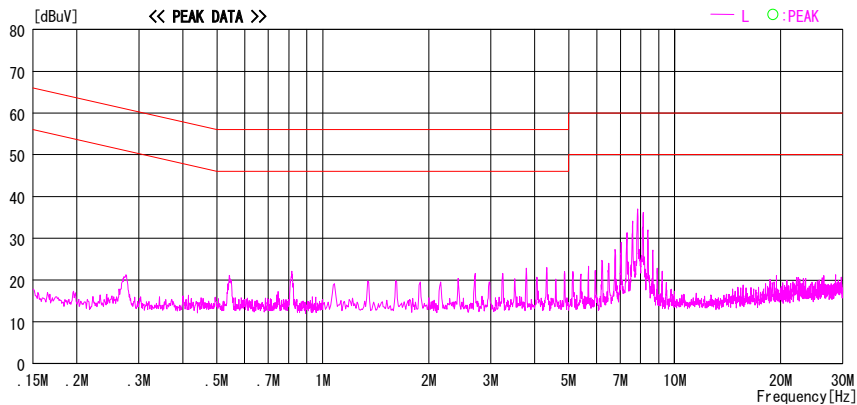
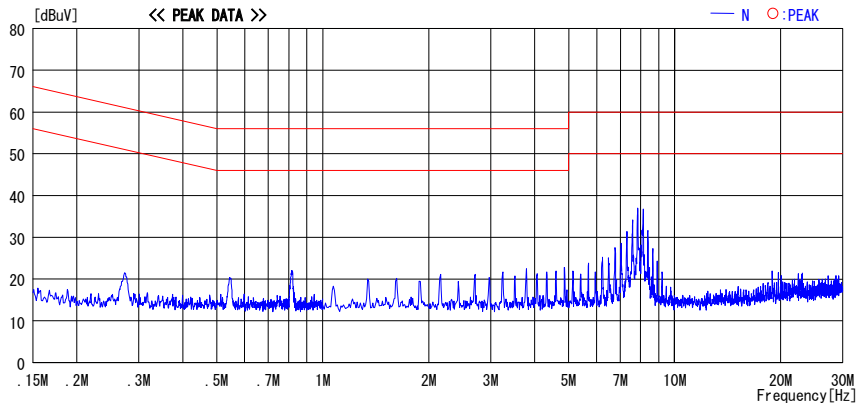

CHART: WITH FACTOR, Peak hold data. CALCURATION: RESULT[dBuV]=READING[dBuV]+C.F[dB] (LISN LOSS+CABLE LOSS)  
 Except for the above table: adequate margin data below the limits.

**Conducted Emission**  
 (Charged Tx, Ant2, Mid)

**DATA OF CONDUCTED EMISSION TEST**

UL Japan, Inc. Head Office EMC Lab. No.3 Semi Anechoic Chamber  
 Date : 2007/10/03

Company	: Panasonic Communications	Report No.	: 28BE0083-HO
Kind of EUT	: Cordless Telephone (Base)	Power	: AC 120V / 60Hz
Model No.	: KX-TG4321	Temp./Humi.	: 24 deg. C. / 64%
Serial No.	: Air001	Operator	: Tomotaka Sasagawa

Mode / Remarks : Transmitting , Mch , 5798.053MHz , ANT2

LIMIT : FCC15.207 QP  
 FCC15.207 AV

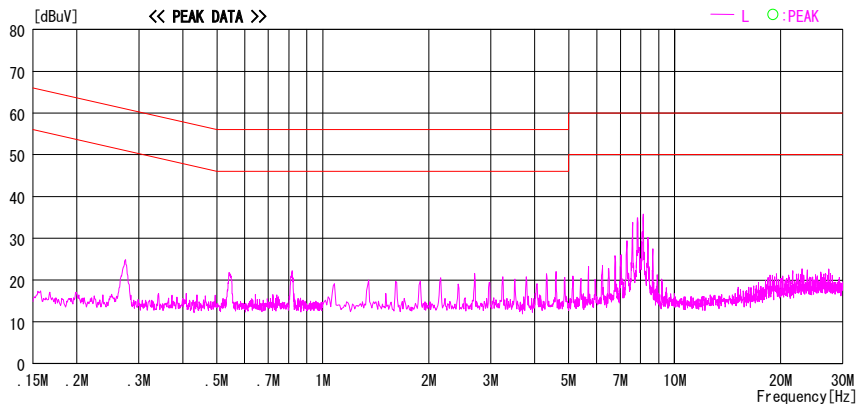
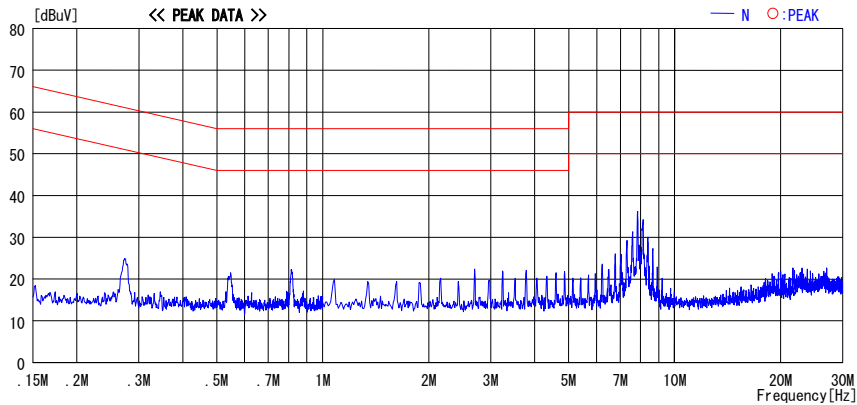

CHART: WITH FACTOR, Peak hold data. CALCURATION: RESULT[dBuV]=READING[dBuV]+C.F[dB] (LISN LOSS+CABLE LOSS)  
 Except for the above table: adequate margin data below the limits.

**Conducted Emission**  
 (Charged Tx, Ant1, High)

**DATA OF CONDUCTED EMISSION TEST**

UL Japan, Inc. Head Office EMC Lab. No.3 Semi Anechoic Chamber  
 Date : 2007/10/03

Company	: Panasonic Communications	Report No.	: 28BE0083-HO
Kind of EUT	: Cordless Telephone (Base)	Power	: AC 120V / 60Hz
Model No.	: KX-TG4321	Temp./Humi.	: 24 deg. C. / 64%
Serial No.	: Air001	Operator	: Tomotaka Sasagawa

Mode / Remarks : Transmitting , Hch , 5838.185MHz , ANT1

LIMIT : FCC15.207 QP  
 FCC15.207 AV

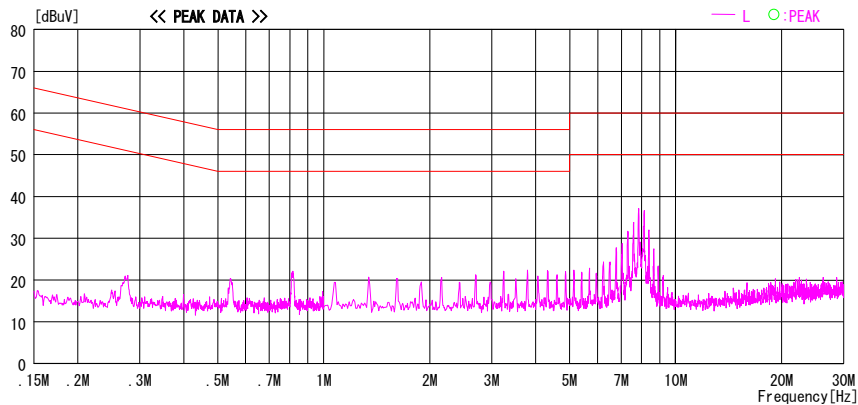
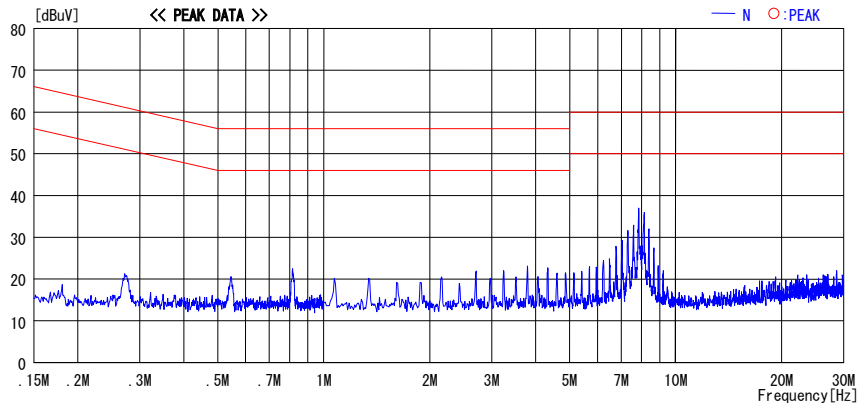

CHART: WITH FACTOR, Peak hold data. CALCURATION: RESULT[dBuV]=READING[dBuV]+C.F[dB] (LISN LOSS+CABLE LOSS)  
 Except for the above table: adequate margin data below the limits.

**Conducted Emission**  
 (Charged Tx, Ant2, High)

**DATA OF CONDUCTED EMISSION TEST**

UL Japan, Inc. Head Office EMC Lab. No.3 Semi Anechoic Chamber  
 Date : 2007/10/03

Company	: Panasonic Communications	Report No.	: 28BE0083-HO
Kind of EUT	: Cordless Telephone (Base)	Power	: AC 120V / 60Hz
Model No.	: KX-TG4321	Temp./Humi.	: 24 deg. C. / 64%
Serial No.	: Air001	Operator	: Tomotaka Sasagawa

Mode / Remarks : Transmitting , Hch , 5838.185MHz .

LIMIT : FCC15.207 QP  
 FCC15.207 AV

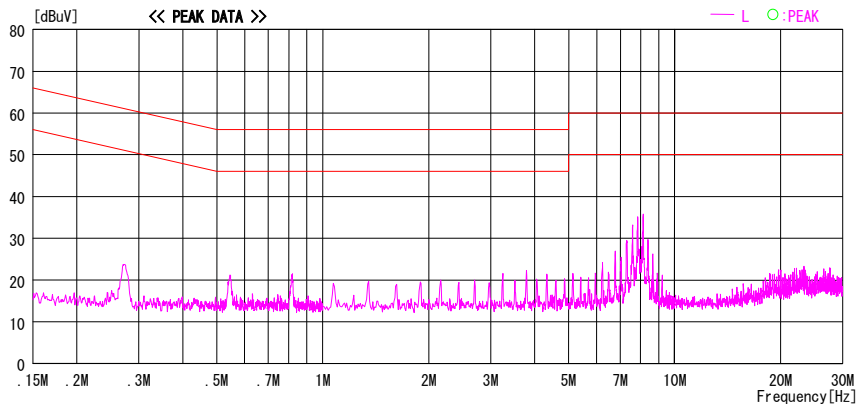
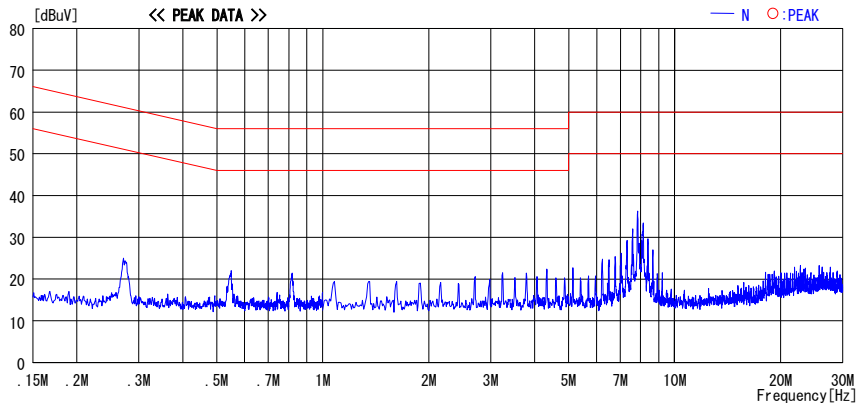

CHART: WITH FACTOR, Peak hold data. CALCURATION: RESULT[dBuV]=READING[dBuV]+C.F[dB] (LISN LOSS+CABLE LOSS)  
 Except for the above table: adequate margin data below the limits.

**Conducted Emission**  
 (Charged Rx, Ant1, Mid)

**DATA OF CONDUCTED EMISSION TEST**

UL Japan, Inc. Head Office EMC Lab. No.3 Semi Anechoic Chamber  
 Date : 2007/10/03

Company : Panasonic Communications  
 Kind of EUT : Cordless Telephone(Base)  
 Model No. : KX-TG4321  
 Serial No. : Air001  
 Report No. : 28BE0083-HO  
 Power : AC 120V / 60Hz  
 Temp./Humi. : 24 deg.C. / 64%  
 Operator : Tomotaka Sasagawa

Mode / Remarks : Receiving, Mch, 5798.053MHz, ANT1

LIMIT : FCC15.207 QP  
 FCC15.207 AV

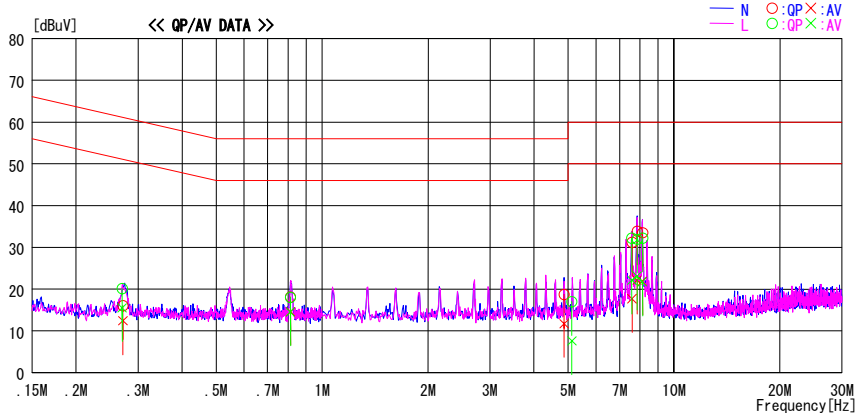

Frequency [MHz]	Reading Level		Corr. Factor [dB]	Results		Limit		Margin		Phase
	QP [dBuV]	AV [dBuV]		QP [dBuV]	AV [dBuV]	QP [dBuV]	AV [dBuV]	QP [dB]	AV [dB]	
0.27155	15.7	12.1	0.3	16.0	12.4	61.1	51.1	45.1	38.7	N
0.81301	17.8	14.3	0.3	18.1	14.6	56.0	46.0	37.9	31.4	N
4.86999	17.9	10.9	0.8	18.7	11.7	56.0	46.0	37.3	34.3	N
7.59694	30.2	16.7	1.0	31.2	17.7	60.0	50.0	28.8	32.3	N
7.84893	32.9	21.1	1.0	33.9	22.1	60.0	50.0	26.1	27.9	N
8.13693	32.5	20.9	1.0	33.5	21.9	60.0	50.0	26.5	28.1	N
0.27011	19.8	15.2	0.3	20.1	15.5	61.1	51.1	41.0	35.6	L
0.81223	17.7	14.2	0.3	18.0	14.5	56.0	46.0	38.0	31.5	L
5.12412	16.2	6.8	0.8	17.0	7.6	60.0	50.0	43.0	42.4	L
7.59182	31.2	21.1	1.0	32.2	22.1	60.0	50.0	27.8	27.9	L
7.85212	30.9	22.1	1.0	31.9	23.1	60.0	50.0	28.1	26.9	L
8.13211	31.2	20.7	1.0	32.2	21.7	60.0	50.0	27.8	28.3	L

CHART: WITH FACTOR, Peak hold data. CALCULATION: RESULT [dBuV] = READING [dBuV] + C.F [dB] (L: ISN LOSS + CABLE LOSS)  
 Except for the above table: adequate margin data below the limits.

**Conducted Emission**  
 (Charged Rx, Ant2, Mid)

**DATA OF CONDUCTED EMISSION TEST**

UL Japan, Inc. Head Office EMC Lab. No.3 Semi Anechoic Chamber  
 Date : 2007/10/03

Company	: Panasonic Communications	Report No.	: 28BE0083-HO
Kind of EUT	: Cordless Telephone(Base)	Power	: AC 120V / 60Hz
Model No.	: KX-TG4321	Temp./Humi.	: 24 deg. C. / 64%
Serial No.	: Air001	Operator	: Tomotaka Sasagawa

Mode / Remarks : Receiving , Mch , 5798.053MHz , ANT2

LIMIT : FCC15.207 QP  
FCC15.207 AV

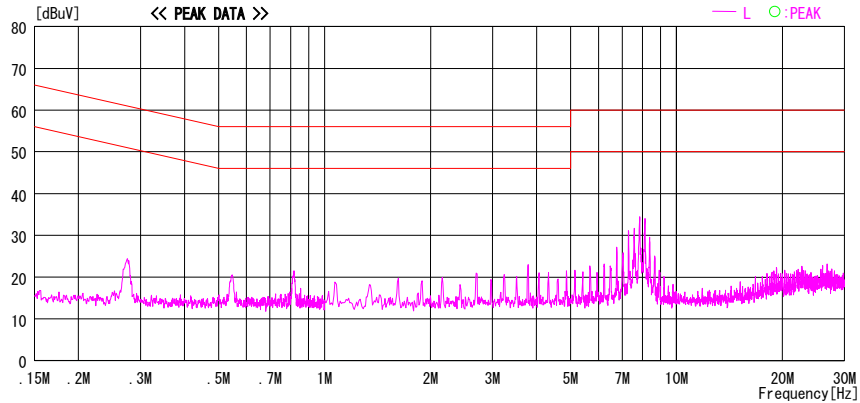
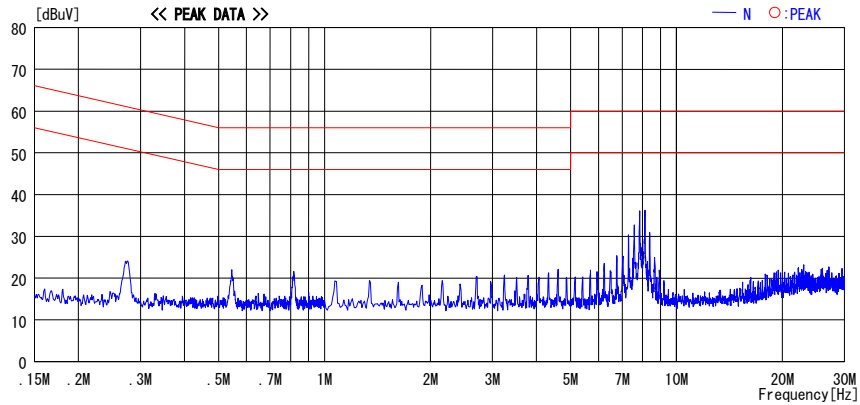

CHART: WITH FACTOR, Peak hold data. CALCURATION: RESULT[dBuV]=READING[dBuV]+C. F[dB] (L1SN LOSS+CABLE LOSS)  
 Except for the above table: adequate margin data below the limits.

**Conducted Emission**  
 (Non-Charged Tx, Ant1, Low)

**DATA OF CONDUCTED EMISSION TEST**

UL Japan, Inc. Head Office EMC Lab. No. 3 Semi Anechoic Chamber  
 Date : 2007/10/10

Company	: Panasonic Communications	Report No.	: 28BE0083-HO
Kind of EUT	: Cordless Telephone(Base)	Power	: AC 120V / 60Hz
Model No.	: KX-TG4321	Temp./Humi.	: 24 deg. C. / 64%
Serial No.	: Air001	Operator	: Tomotaka Sasagawa

Mode / Remarks : Transmitting , Lch , 5759.7MHz , ANT1 , Non-Charged

LIMIT : FCC15.207 QP  
 FCC15.207 AV

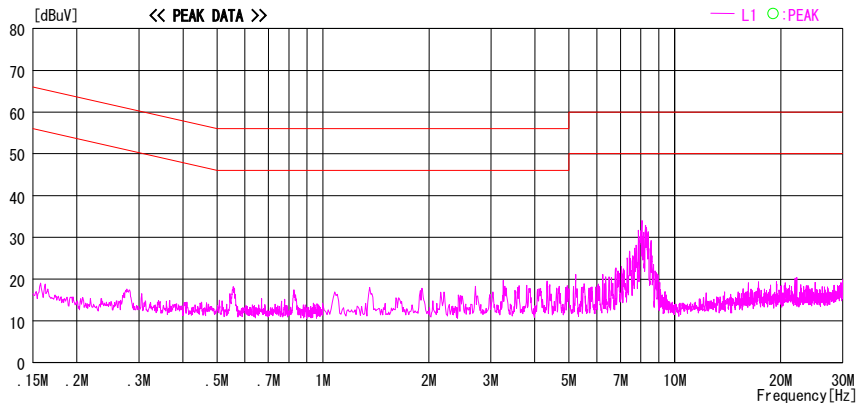
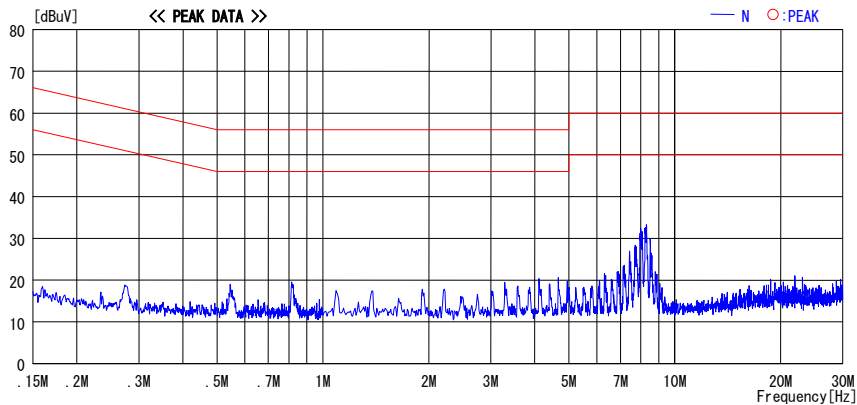

CHART: WITH FACTOR, Peak hold data. CALCULATION: RESULT [dBuV]=READING [dBuV]+C. F [dB] (LISN LOSS+CABLE LOSS)  
 Except for the above table: adequate margin data below the limits.

**Conducted Emission**  
 (Non-Charged Tx, Ant1, Mid)

**DATA OF CONDUCTED EMISSION TEST**

UL Japan, Inc. Head Office EMC Lab. No. 3 Semi Anechoic Chamber  
 Date : 2007/10/10

Company	: Panasonic Communications	Report No.	: 28BE0083-HO
Kind of EUT	: Cordless Telephone (Base)	Power	: AC 120V / 60Hz
Model No.	: KX-TG4321	Temp./Humi.	: 24 deg. C. / 64%
Serial No.	: Air001	Operator	: Tomotaka Sasagawa

Mode / Remarks : Transmitting , Mch , 5798.053MHz , ANT1 , Non-Charged

LIMIT : FCC15.207 QP  
 FCC15.207 AV

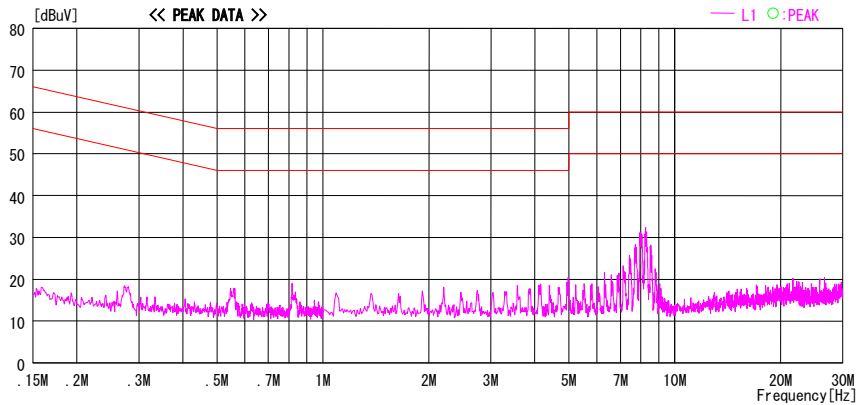
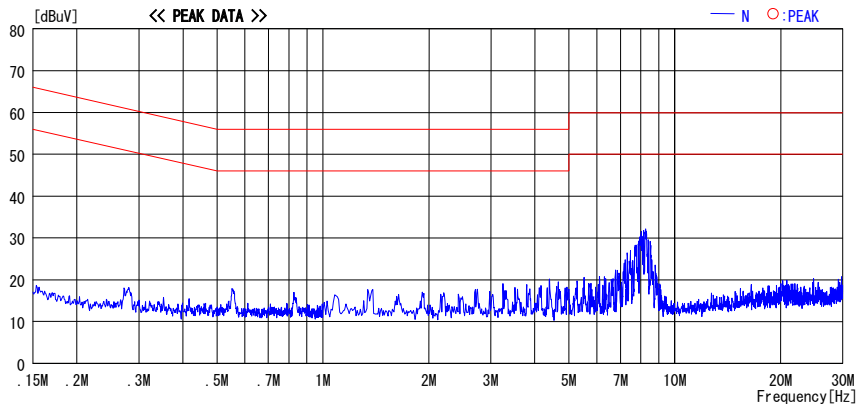

CHART WITH FACTOR, Peak hold data. CALCULATION: RESULT [dBuV] = READING [dBuV] + C. F [dB] (LISN LOSS + CABLE LOSS)  
 Except for the above table: adequate margin data below the limits.

**Conducted Emission**  
 (Non-Charged Tx, Ant1, High)

**DATA OF CONDUCTED EMISSION TEST**

UL Japan, Inc. Head Office EMC Lab. No.3 Semi Anechoic Chamber  
 Date : 2007/10/10

Company	: Panasonic Communications	Report No.	: 28BE0083-HO
Kind of EUT	: Cordless Telephone (Base)	Power	: AC 120V / 60Hz
Model No.	: KX-TG4321	Temp./Humi.	: 24 deg. C. / 64%
Serial No.	: Air001	Operator	: Tomotaka Sasagawa

Mode / Remarks : Transmitting , Hch , 5838.185MHz , ANT1 , Non-Charged

LIMIT : FCC15.207 QP  
 FCC15.207 AV

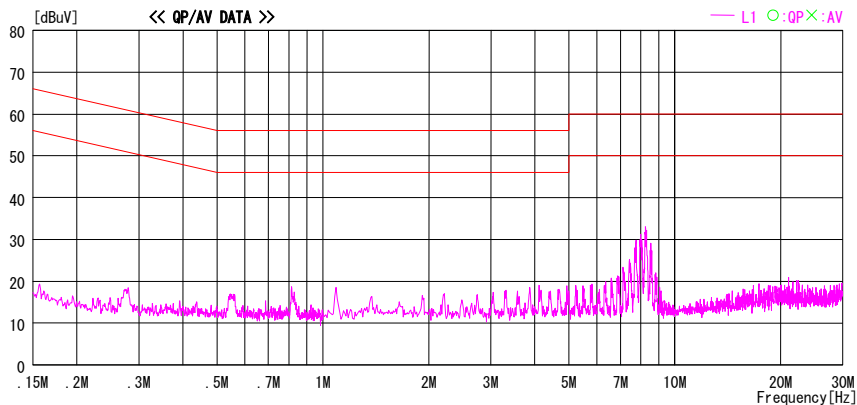
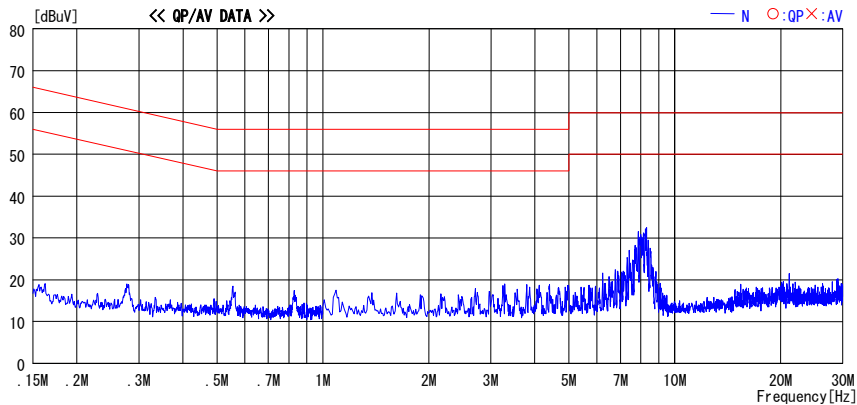

CHART: WITH FACTOR, Peak hold data. CALCURATION: RESULT [dBuV] = READING [dBuV] + C. F [dB] (LISN LOSS + CABLE LOSS)  
 Except for the above table: adequate margin data below the limits.

**Conducted Emission**  
 (Non-Charged Rx, Ant1, Mid)

**DATA OF CONDUCTED EMISSION TEST**

UL Japan, Inc. Head Office EMC Lab. No. 3 Semi Anechoic Chamber  
 Date : 2007/10/10

Company	: Panasonic Communications	Report No.	: 28BE0083-HO
Kind of EUT	: Cordless Telephone(Base)	Power	: AC 120V / 60Hz
Model No.	: KX-TG4321	Temp./Humi.	: 24 deg. C. / 64%
Serial No.	: Air001	Operator	: Tomotaka Sasagawa

Mode / Remarks : Receiving , Mch , 5798.053MHz , ANT1 , Non-Charged

LIMIT : FCC15.207 QP  
 FCC15.207 AV

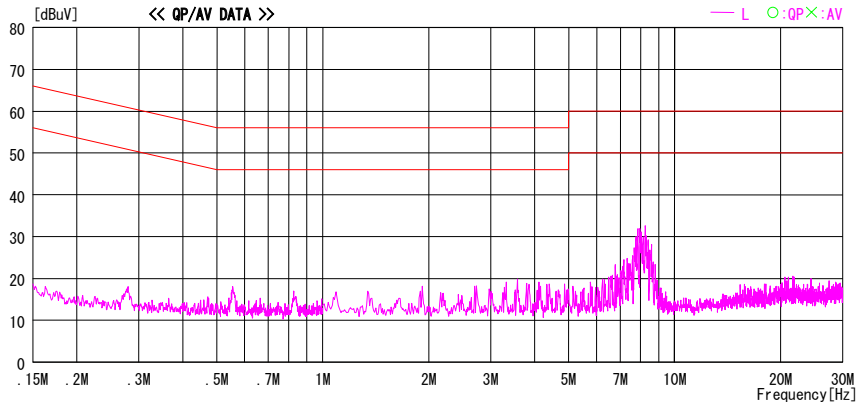
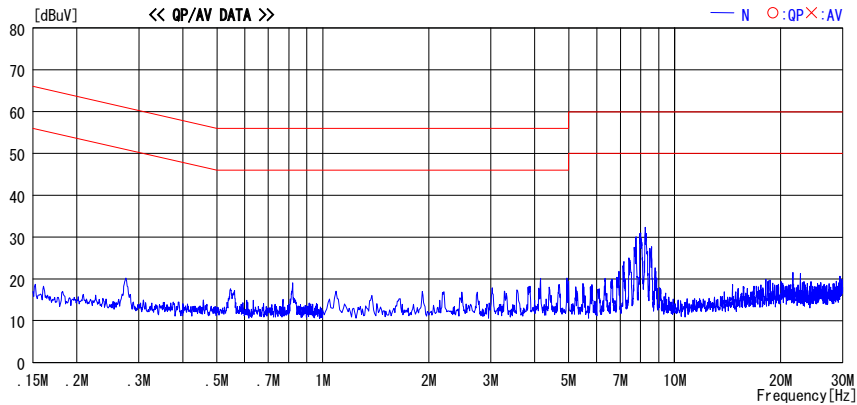

CHART: WITH FACTOR, Peak hold data. CALCURATION: RESULT[dBuV]=READING[dBuV]+C. F[dB] (LISN LOSS+CABLE LOSS)  
 Except for the above table: adequate margin data below the limits.

### Carrier Frequency Separation

Company	Panasonic Communications Co., Ltd.	UL Japan, Inc.
Equipment	Cordless Telephone (Base)	Head Office EMC Lab. No.7 Shielded Room
Model	KX-TG4321	Regulation FCC 15.247(a)(1)(ii)
S/N	RF TEST No.1	Test Distance -
Power	AC120V / 60Hz	Date 10/02/2007
Mode	Tx (Hopping on), Ant1(Worst)	Temperature 24 deg.C.
		Humidity 58 %
		Engineer Makoto Kosaka

Ch	Freq. [MHz]	Channel separation [MHz]	Limit
Low	5759.700	0.887	> 0.630MHz (20dB Bandwidth) or 0.025MHz (whichever is greater)
Mid	5798.053	0.900	> 0.625MHz (20dB Bandwidth) or 0.025MHz (whichever is greater)
High	5838.185	0.880	> 0.635MHz (20dB Bandwidth) or 0.025MHz (whichever is greater)

### Carrier Frequency Separation

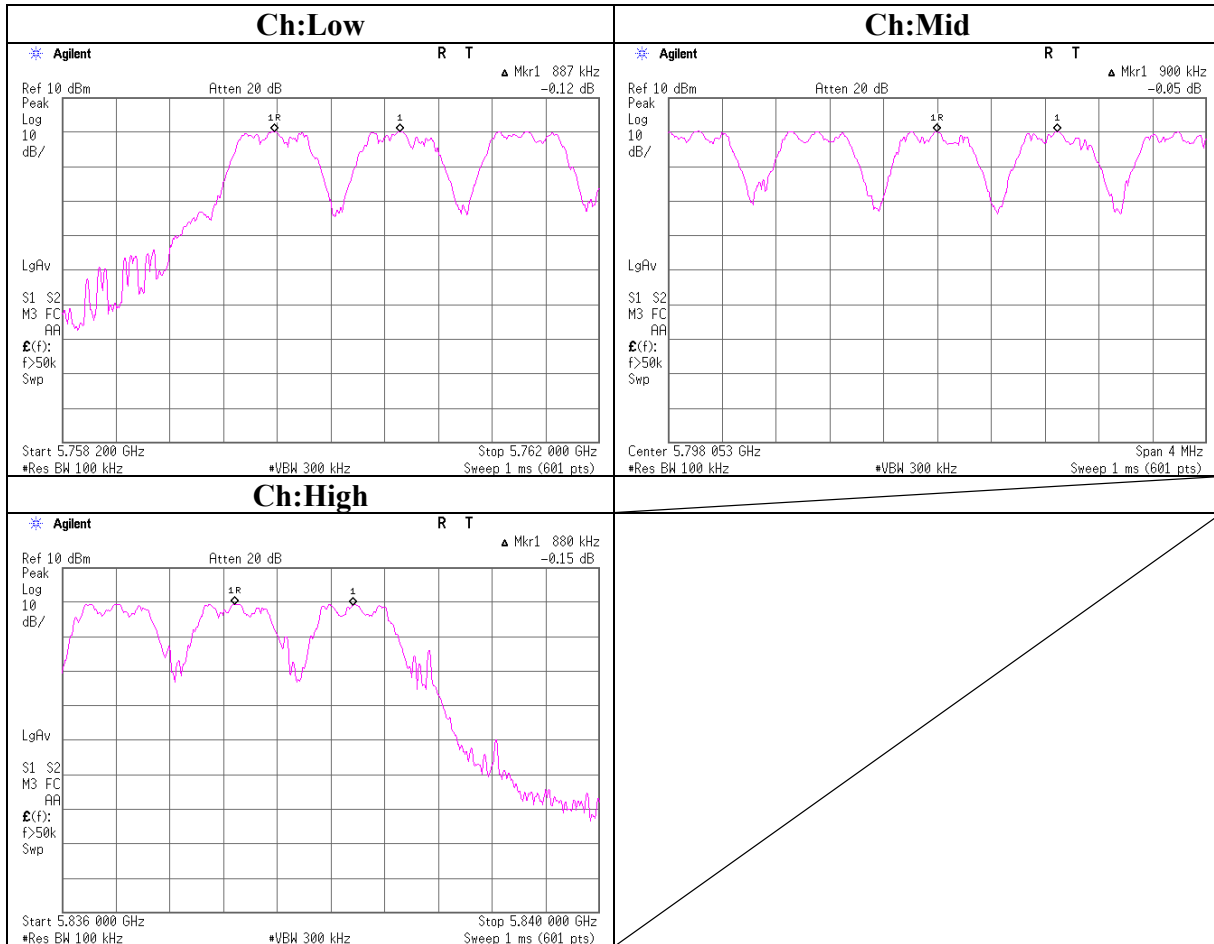

### 20dB Bandwidth

Company	Panasonic Communications Co., Ltd.	UL Japan, Inc.	
Equipment	Cordless Telephone (Base)	Head Office EMC Lab. No.7 Shielded Room	
Model	KX-TG4321	Regulation	FCC15.247(a)(1)
S/N	RF TEST No.1	Test Distance	-
Power	AC120V / 60Hz	Date	10/01/2007
Mode	Tx (Hopping off) , Ant1(Worst)	Temperature	24 deg.C.
		Humidity	67 %
		Engineer	Makoto Kosaka

Ch	Freq. [MHz]	20dB Bandwidth [MHz]	Limit [MHz]
Low	5759.700	0.630	-
Mid	5798.053	0.625	-
High	5838.185	0.635	-

**20dB Bandwidth**

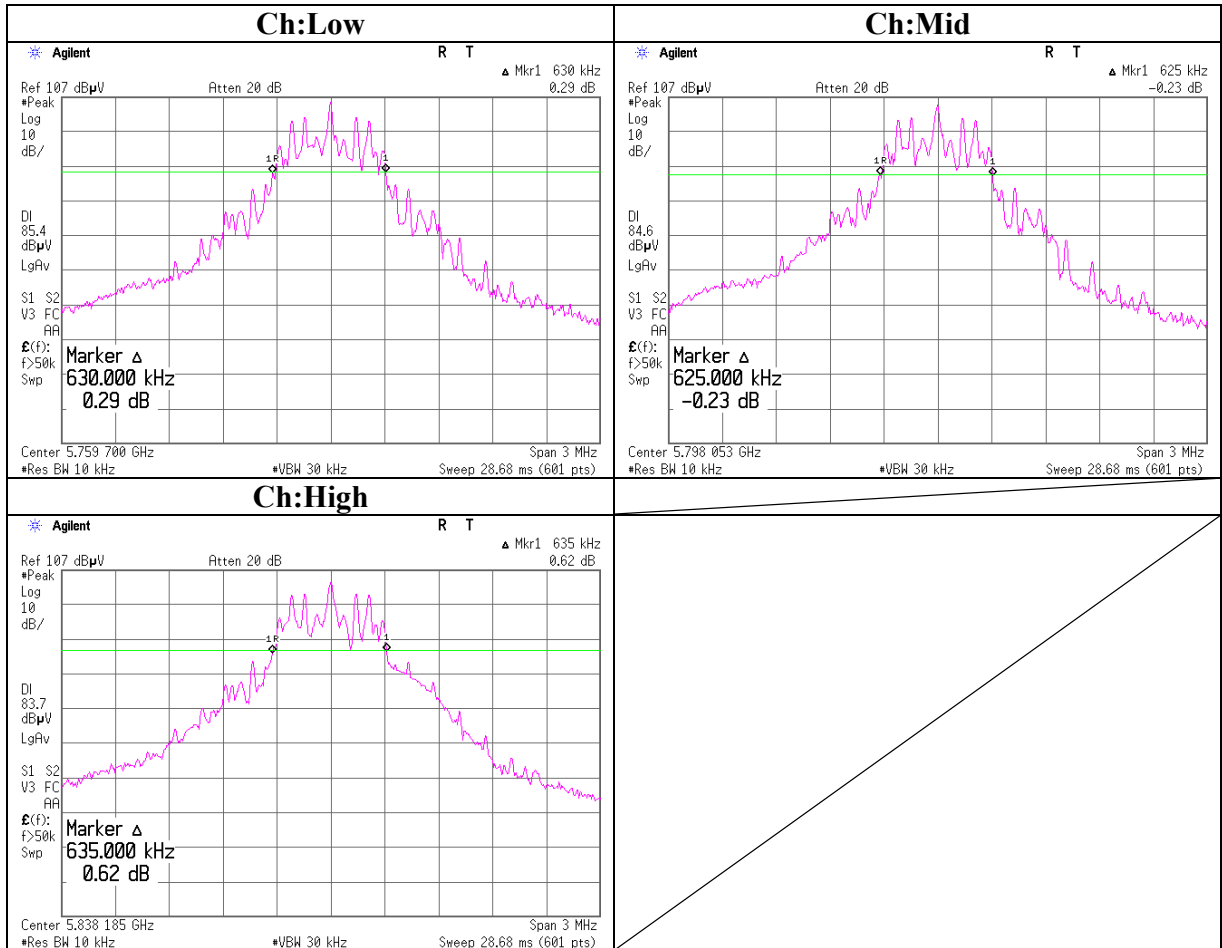

### Number of Hopping Frequency

Company Panasonic Communications Co., Ltd.  
Equipment Cordless Telephone (Base)  
Model KX-TG4321  
S/N RF TEST No.1  
Power AC120V / 60Hz  
Mode Tx (Hopping on), Ant1(Worst)

UL Japan, Inc.  
Head Office EMC Lab. No.7 Shielded Room  
Regulation FCC15.247(a)(1)(ii)  
Test Distance -  
Date 10/02/2007  
Temperature 24 deg.C.  
Humidity 58 %  
Engineer Makoto Kosaka

Mode	Number of channel	Limit
	[time]	[time]
Tx(Hoppng on)	89	$\geq 75$

**Number of Hopping Frequency**

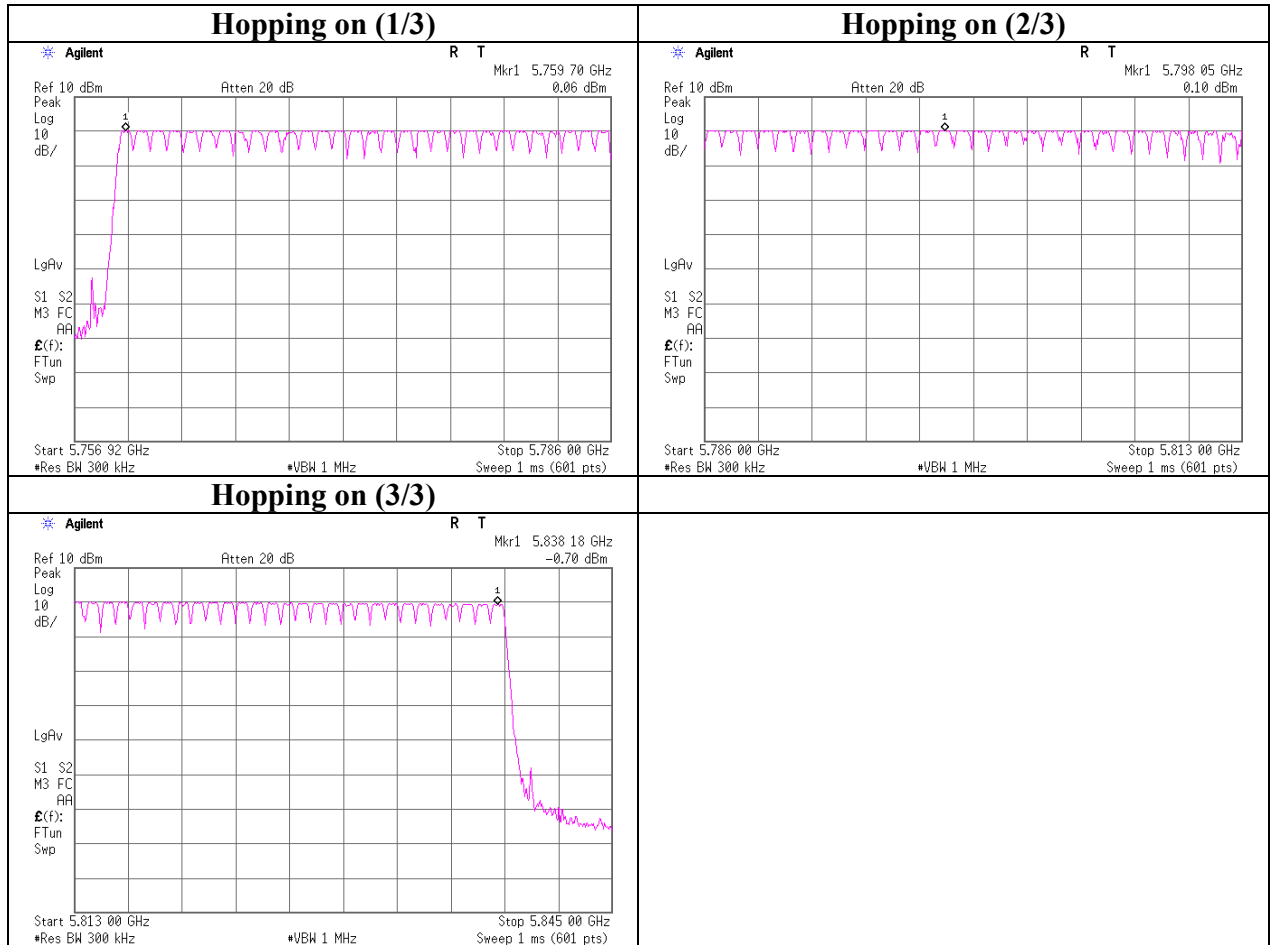

### Dwell time

Company	Panasonic Communications Co., Ltd.	UL Japan, Inc.
Equipment	Cordless Telephone (Base)	Head Office EMC Lab. No.6 Shielded Room
Model	KX-TG4321	Regulation FCC15.247(a)(1)(ii)
S/N	RF TEST No.1	Test Distance -
Power	AC120V / 60Hz	Date 10/02/2007
Mode	Tx (Hopping on), Ant1(Worst)	Temperature 24 deg.C.
		Humidity 58 %
		Engineer Makoto Kosaka

Mode	Number of transmission in a 30 second period	Length of transmission time [msec]	Result [msec]	Limit [msec]
Tx(Hopping on)	70 times / 30 sec. x 30.0 sec. = 70 times	0.975	68	400

### Dwell time

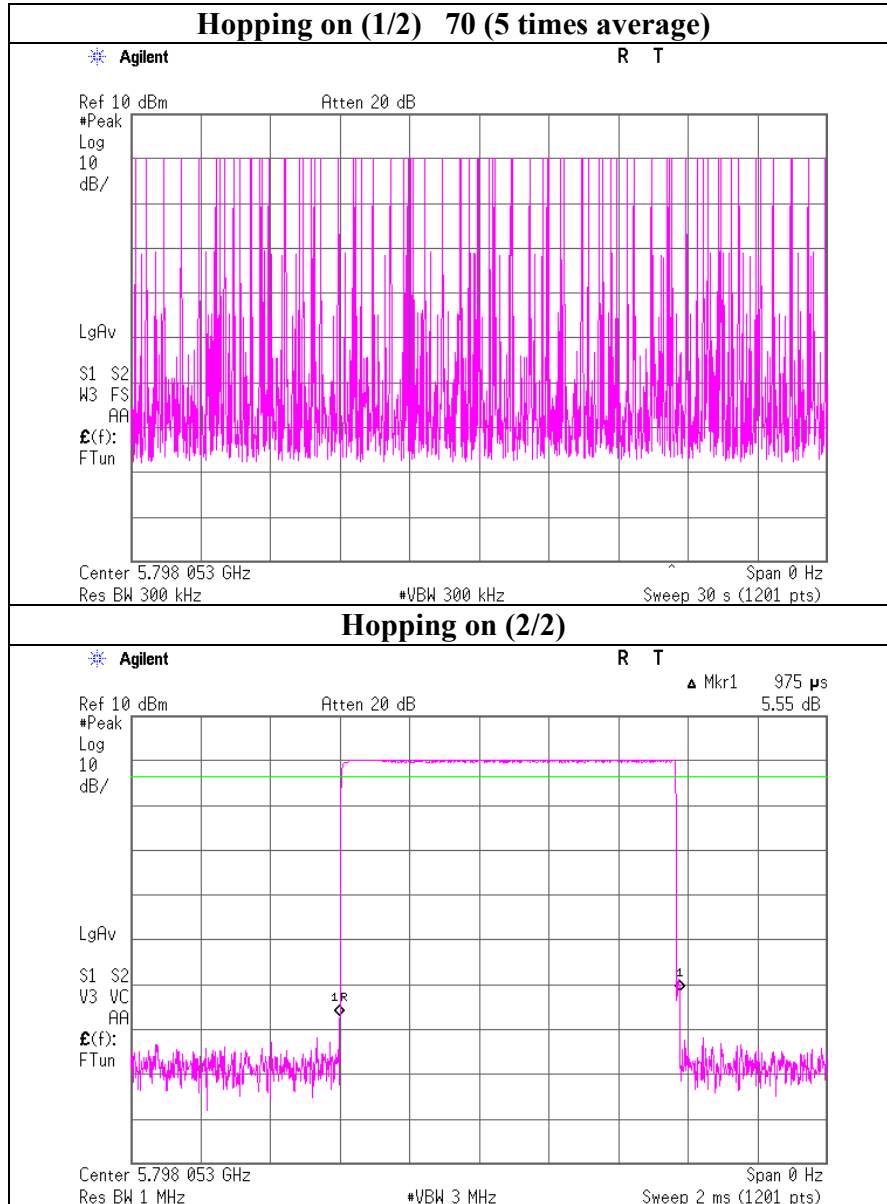

### Maximum Peak Output Power

		UL Japan, Inc.
Company	Panasonic Communications Co., Ltd.	Head Office EMC Lab. No.7 Shielded Room
Equipment	Cordless Telephone (Base)	Regulation FCC15.247(b)(1)
Model	KX-TG4321	Test Distance -
S/N	RF TEST No.1	Date 10/01/2007
Power	AC120V / 60Hz	Temperature 23 deg.C.
Mode	Tx (Hopping off)	Humidity 66 %
		Engineer Makoto Kosaka

**Ant 1 (Worst)**

Ch	Freq. [MHz]	P/M (PK) Reading [dBm]	Atten.+ Cable [dB]	Result		Limit		Margin [dB]
				[dBm]	[mW]	[dBm]	[mW]	
Low	5759.700	0.96	19.68	20.64	115.88	30.00	1000	9.36
Mid	5798.053	0.76	19.68	20.44	110.66	30.00	1000	9.56
High	5838.185	0.41	19.68	20.09	102.09	30.00	1000	9.91

Sample Calculation:

Result = Reading + Cable Loss + Attenuator

\* In the above table, factor 0.0dB represents no use of Atten. and/or Filter.

**Ant 2**

Ch	Freq. [MHz]	P/M (PK) Reading [dBm]	Atten.+ Cable [dB]	Result		Limit		Margin [dB]
				[dBm]	[mW]	[dBm]	[mW]	
Low	5759.700	-0.26	19.68	19.42	87.50	30.00	1000	10.58
Mid	5798.053	-0.25	19.68	19.43	87.70	30.00	1000	10.57
High	5838.185	-0.32	19.68	19.36	86.30	30.00	1000	10.64

Sample Calculation:

Result = Reading + Cable Loss + Attenuator

\* In the above table, factor 0.0dB represents no use of Atten. and/or Filter.

**Radiated Spurious Emission (below 1GHz)**  
(Tx, Ant1, Low)

**DATA OF RADIATED EMISSION TEST**

UL Japan, Inc. Head Office EMC Lab. No. 4 Semi Anechoic Chamber  
Date : 2007/10/03

Company : Panasonic Communications  
Kind of EUT : Cordless Telephone (Base)  
Model No. : KX-TG4321  
Serial No. : Air001  
Report No. : 28BE0083-HO  
Power : AC 120V / 60Hz  
Temp./Humi. : 25deg. C / 52%  
Operator : Tomotaka Sasagawa

Mode / Remarks : Transmitting , Lch , 5759.7MHz, ANT1

LIMIT : FCC15.247(d) 3m, below 1GHz:QP, above 1GHz:PK  
FCC15.247(d) 3m, below 1GHz:QP, above 1GHz:AV

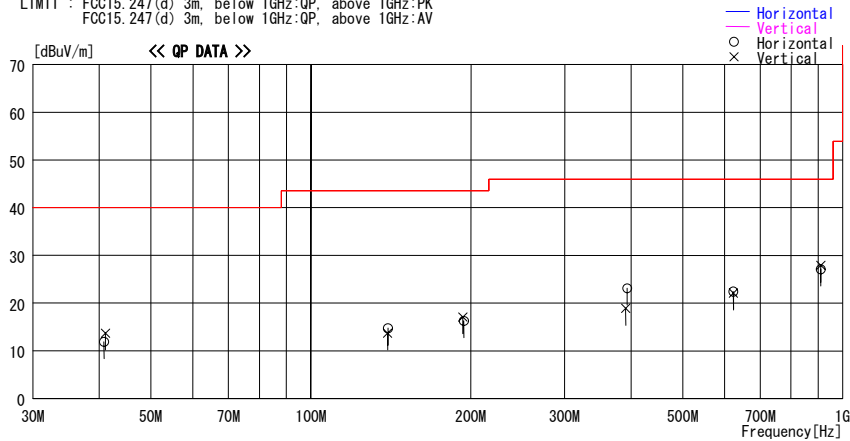

Frequency [MHz]	Reading [dBuV]	DET	Antenna		Level [dBuV/m]	Angle [Deg]	Height [cm]	Polar.	Limit [dBuV/m]	Margin [dB]	Comment
			Factor [dB/m]	Loss& Gain [dB]							
40.800	23.2	QP	13.5	-24.8	11.9	236	250	Hori.	40.0	28.1	
41.070	25.1	QP	13.4	-24.8	13.7	131	100	Vert.	40.0	26.3	
139.349	22.6	QP	14.6	-23.5	13.7	1	100	Vert.	43.5	29.8	
139.619	23.6	QP	14.6	-23.5	14.7	346	250	Hori.	43.5	28.8	
193.080	23.4	QP	16.6	-22.9	17.1	201	100	Vert.	43.5	26.4	
193.890	22.6	QP	16.6	-22.9	16.3	13	250	Hori.	43.5	27.2	
391.002	23.3	QP	17.1	-21.5	18.9	43	100	Vert.	46.0	27.1	
393.224	27.4	QP	17.2	-21.5	23.1	23	100	Hori.	46.0	22.9	
622.706	23.4	QP	19.3	-20.3	22.4	277	100	Hori.	46.0	23.6	
623.406	23.1	QP	19.3	-20.3	22.1	81	100	Vert.	46.0	23.9	
909.711	23.1	QP	21.8	-17.8	27.1	52	100	Hori.	46.0	18.9	
909.711	23.9	QP	21.8	-17.8	27.9	226	100	Vert.	46.0	18.1	

CHART: WITH FACTOR ANT TYPE: -30MHz: LOOP, 30-300MHz: BICONICAL, 300MHz-1000MHz: LOGPERIODIC, 1000MHz-: HORN  
CALCULATION: RESULT = READING + ANT FACTOR + LOSS (CABLE+ATTEN.) - GAIN (AMP)

\*The limit is rounded down to one decimal place. \*The test result is round off to one or two decimal places, so some differences might be observed.

**Radiated Spurious Emission (below 1GHz)**  
(Tx, Ant1, Mid)

**DATA OF RADIATED EMISSION TEST**

UL Japan, Inc. Head Office EMC Lab. No.4 Semi Anechoic Chamber  
Date : 2007/10/03

Company : Panasonic Communications Report No. : 28BE0083-HO  
Kind of EUT : Cordless Telephone (Base) Power : AC 120V / 60Hz  
Model No. : KX-TG4321 Temp./Humi. : 25deg. C / 52%  
Serial No. : Air001 Operator : Tomotaka Sasagawa

Mode / Remarks: Transmitting, Mch., 5759.7MHz, ANT1

LIMIT : FCC15.247(d) 3m, below 1GHz:QP, above 1GHz:PK  
FCC15.247(d) 3m, below 1GHz:QP, above 1GHz:AV

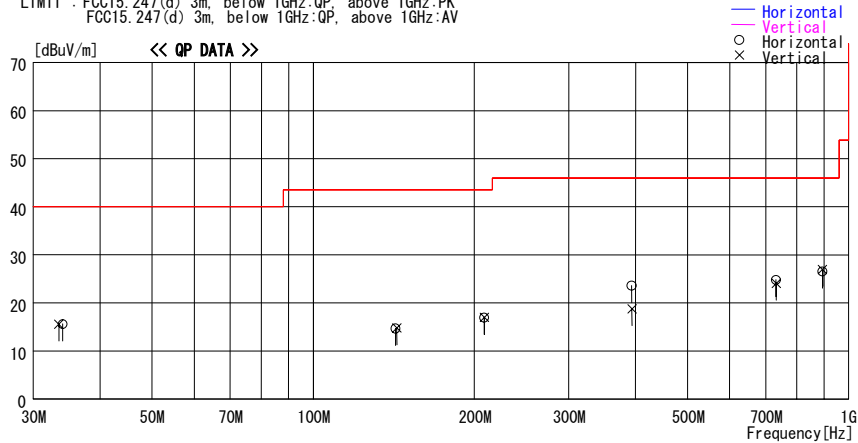

Frequency [MHz]	Reading [dBUV]	DET	Antenna		Level [dBUV/m]	Angle [Deg.]	Height [cm]	Polar.	Limit [dBUV/m]	Margin [dB]	Comment
			Factor [dB/m]	Loss & Gain [dB]							
33.510	22.9	QP	17.7	-25.0	15.6	111	100	Vert.	40.0	24.4	
34.050	23.1	QP	17.4	-24.9	15.6	350	250	Hori.	40.0	24.4	
142.590	23.4	QP	14.8	-23.5	14.7	345	250	Hori.	43.5	28.8	
143.400	23.4	QP	14.8	-23.4	14.8	129	100	Vert.	43.5	28.7	
208.471	23.1	QP	16.7	-22.8	17.0	355	250	Hori.	43.5	26.5	
209.011	23.1	QP	16.7	-22.8	17.0	23	100	Vert.	43.5	26.5	
393.271	27.9	QP	17.2	-21.5	23.6	347	100	Hori.	46.0	22.4	
393.802	23.1	QP	17.2	-21.5	18.9	181	100	Vert.	46.0	27.2	
731.908	24.1	QP	20.3	-19.6	24.9	271	100	Hori.	46.0	21.2	
732.608	23.4	QP	20.3	-19.6	24.1	34	100	Vert.	46.0	21.9	
893.610	22.8	QP	21.7	-17.9	26.6	304	100	Hori.	46.0	19.4	
894.310	23.2	QP	21.7	-17.9	27.0	321	100	Vert.	46.0	19.0	

CHART WITH FACTOR ANT TYPE: -30MHz: LOOP, 30-300MHz: BICONICAL, 300MHz-1000MHz: LOGPERIODIC, 1000MHz-: HORN  
CALCULATION: RESULT = READING + ANT FACTOR + LOSS (CABLE+ATTEN.) - GAIN (AMP)

\*The limit is rounded down to one decimal place. \*The test result is round off to one or two decimal places, so some differences might be observed.

**UL Japan, Inc.**  
**Head Office EMC Lab.**  
4383-326 Asama-cho, Ise-shi, Mie-ken 516-0021 JAPAN  
Telephone : +81 596 24 8116  
Facsimile : +81 596 24 8124

**Radiated Spurious Emission (below 1GHz)**  
 (Tx, Ant1, High)

**DATA OF RADIATED EMISSION TEST**

UL Japan, Inc. Head Office EMC Lab. No.4 Semi Anechoic Chamber  
 Date : 2007/10/03

Company : Panasonic Communications      Report No. : 28BE0083-HO  
 Kind of EUT : Cordless Telephone (Base)      Power : AC 120V / 60Hz  
 Model No. : KX-TG4321      Temp./Humi. : 25deg. C / 52%  
 Serial No. : Air001      Operator : Tomotaka Sasagawa

Mode / Remarks: Transmitting, Hch, 5838.185MHz ANT1

LIMIT : FCC15.247(d) 3m, below 1GHz:QP, above 1GHz:PK  
 FCC15.247(d) 3m, below 1GHz:QP, above 1GHz:AV

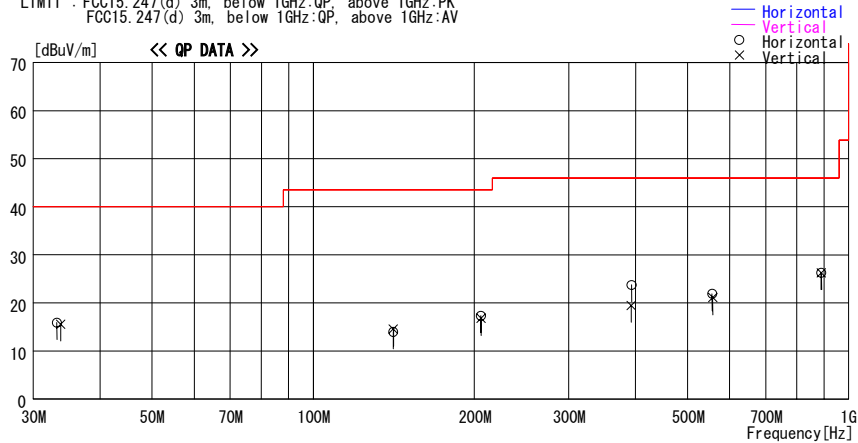

Frequency [MHz]	Reading [dBuV]	DET	Antenna		Level [dBuV/m]	Angle [Deg.]	Height [cm]	Polar.	Limit [dBuV/m]	Margin [dB]	Comment
			Factor [dB/m]	Loss & Gain [dB]							
33.227	23.1	QP	17.8	-25.0	15.9	194	250	Hori.	40.0	24.1	
33.780	23.1	QP	17.5	-25.0	15.6	99	100	Vert.	40.0	24.4	
140.970	22.8	QP	14.7	-23.5	14.0	156	250	Hori.	43.5	29.5	
141.240	23.4	QP	14.7	-23.5	14.6	127	100	Vert.	43.5	28.9	
205.501	23.4	QP	16.7	-22.8	17.3	41	250	Hori.	43.5	26.2	
205.771	22.9	QP	16.7	-22.8	16.8	177	100	Vert.	43.5	26.7	
393.230	28.1	QP	17.2	-21.5	23.8	20	100	Hori.	46.0	22.2	
392.771	23.8	QP	17.2	-21.5	19.5	103	100	Vert.	46.0	26.5	
555.505	23.5	QP	18.9	-20.5	21.9	6	100	Hori.	46.0	24.1	
557.605	22.7	QP	18.9	-20.5	21.1	333	100	Vert.	46.0	24.9	
888.710	22.6	QP	21.7	-18.0	26.3	169	100	Hori.	46.0	19.7	
889.410	22.6	QP	21.7	-18.0	26.3	4	100	Vert.	46.0	19.7	

CHART WITH FACTOR ANT TYPE: -30MHz: LOOP, 30-300MHz: BICONICAL, 300MHz-1000MHz: LOGPERIODIC, 1000MHz-: HORN  
 CALCULATION: RESULT = READING + ANT FACTOR + LOSS (CABLE+ATTEN.) - GAIN (AMP)

\*The limit is rounded down to one decimal place. \*The test result is round off to one or two decimal places, so some differences might be observed.

**UL Japan, Inc.**  
**Head Office EMC Lab.**  
 4383-326 Asama-cho, Ise-shi, Mie-ken 516-0021 JAPAN  
 Telephone : +81 596 24 8116  
 Facsimile : +81 596 24 8124

**Radiated Spurious Emission (below 1GHz)**  
(Rx, Ant1, Mid)

**DATA OF RADIATED EMISSION TEST**

UL Japan, Inc. Head Office EMC Lab. No.4 Semi Anechoic Chamber  
Date : 2007/10/03

Company : Panasonic Communications Report No. : 28BE0083-HO  
Kind of EUT : Cordless Telephone(Base) Power : AC 120V / 60Hz  
Model No. : KX-TG4321 Temp./Humi. : 25deg. C / 52%  
Serial No. : Air001 Operator : Tomotaka Sasagawa

Mode / Remarks: Receiving, Mch, 5759.7MHz, Worst-axis(Hor:X / Ver:Y), ANT1

LIMIT : FCC15.247(d) 3m, below 1GHz:QP, above 1GHz:PK  
FCC15.247(d) 3m, below 1GHz:QP, above 1GHz:AV

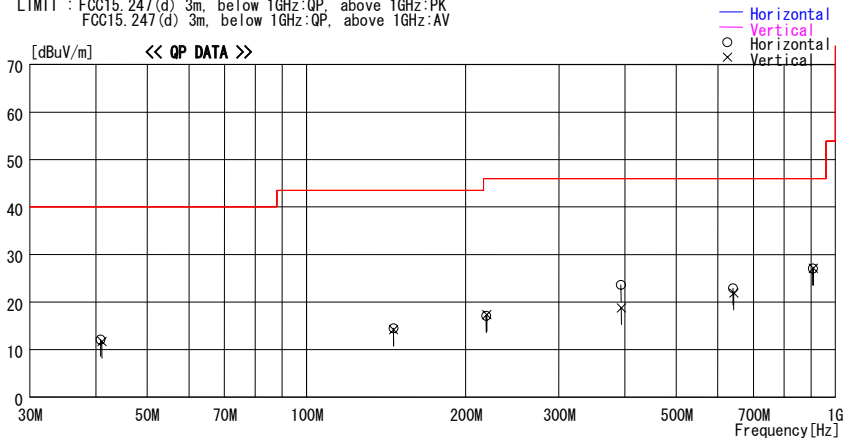

Frequency [MHz]	Reading [dBuV]	DET	Antenna		Level [dBuV/m]	Angle [Deg]	Height [cm]	Polar.	Limit [dBuV/m]	Margin [dB]	Comment
			Factor [dB/m]	Loss & Gain [dB]							
40.800	23.4	QP	13.5	-24.8	12.1	249	250	Hori.	40.0	27.9	
41.070	23.1	QP	13.4	-24.8	11.7	121	100	Vert.	40.0	28.3	
146.100	22.9	QP	15.0	-23.4	14.5	136	250	Hori.	43.5	29.0	
146.100	22.6	QP	15.0	-23.4	14.2	203	100	Vert.	43.5	29.3	
218.461	22.9	QP	16.9	-22.7	17.1	352	250	Hori.	46.0	28.9	
219.271	23.2	QP	16.9	-22.7	17.4	355	100	Vert.	46.0	28.6	
393.210	27.9	QP	17.2	-21.5	23.6	152	100	Hori.	46.0	22.4	
393.802	23.1	QP	17.2	-21.5	18.8	3	100	Vert.	46.0	27.2	
640.206	23.8	QP	19.3	-20.2	22.9	267	100	Hori.	46.0	23.1	
642.306	22.7	QP	19.4	-20.2	21.9	11	100	Vert.	46.0	24.1	
906.911	23.1	QP	21.8	-17.8	27.1	39	100	Hori.	46.0	18.9	
908.311	23.1	QP	21.8	-17.8	27.1	13	100	Vert.	46.0	18.9	

CHART: WITH FACTOR ANT TYPE: -30MHz: LOOP, 30-300MHz: BICONICAL, 300MHz-1000MHz: LOGPERIODIC, 1000MHz-: HORN  
CALCULATION: RESULT = READING + ANT FACTOR + LOSS (CABLE+ATTEN.) - GAIN (AMP)

\* The result is rounded off to the second decimal place. Therefore, there may be 0.1 difference for the result.

**Radiated Spurious Emission (above 1GHz)**  
(Tx, Ant1, Low)

Company : Panasonic Communications Co., Ltd.  
Equipment : Cordless Telephone (Base)  
Model : KX-TG4321  
S/N : Air001  
Power : DC3.6V  
Mode : Tx Low 5759.7MHz  
Position : H: X-axis, V: Y-axis, Worst Ant: Ant1

UL Japan, Inc.  
Head Office EMC Lab. No.4 & 3 Semi Anechoic Chamber  
Regulation : FCC15.247(d)  
Test Distance : 3m / 1m / 0.5m  
Date : 10/01/2007, 10/02/2007  
Temperature : 25 deg.C. , 25deg.C.  
Humidity : 52 % , 52%  
Engineer : Tomotaka Sasagawa

**PK DETECT** (RBW: 1MHz, VBW: 1MHz)

No.	FREQ [MHz]	S/A READING		ANT Factor [dB/m]	AMP GAIN [dB]	CABLE LOSS [dB]	Hi-Pass Filter [dB]	RESULT		Limit PK [dBuV/m]	MARGIN	
		HOR	VER					HOR	VER		HOR	VER
<b>Test distance 3meters RESULT=Reading + ANT Factor - Amp Gain + Cable Loss + Filter Loss</b>												
1	4319.23	58.9	57.7	29.7	31.2	3.8	0.0	61.2	60.0	73.9	12.7	13.9
2	5460.00	40.5	42.8	31.5	31.1	4.1	0.0	45.0	47.3	73.9	28.9	26.6
3	5725.00	40.2	44.7	31.9	31.1	4.2	0.0	45.2	49.7	73.9	28.7	24.2
<b>Test distance 1meters RESULT=Reading + ANT Factor - Amp Gain + Cable Loss + Filter Loss - Dfac</b>												
4	11519.40	51.3	55.6	39.7	32.4	6.4	0.6	56.1	60.4	73.9	17.8	13.5
5	17225.60	46.9	49.5	42.7	31.1	7.5	0.6	57.1	59.7	73.9	16.8	14.2
6	23038.80	48.4	46.8	38.7	31.4	8.8	0.7	55.7	54.1	73.9	18.2	19.8
<b>Test distance 0.5meters RESULT=Reading + ANT Factor - Amp Gain + Cable Loss + Filter Loss - Dfac</b>												
7	34451.19	42.1	41.9	40.5	28.2	16.5	0.0	55.3	55.1	73.9	18.6	18.8

**AV DETECT** (RBW: 1MHz, VBW: 10Hz)

No.	FREQ [MHz]	S/A READING		ANT Factor [dB/m]	AMP GAIN [dB]	CABLE LOSS [dB]	Hi-Pass Filter [dB]	RESULT		Limit AV [dBuV/m]	MARGIN	
		HOR	VER					HOR	VER		HOR	VER
<b>Test distance 3meters RESULT=Reading + ANT Factor - Amp Gain + Cable Loss + Filter Loss</b>												
1	4319.23	34.0	34.9	29.7	31.2	3.8	0.0	36.3	37.2	53.9	17.6	16.7
2	5460.00	30.9	30.3	31.5	31.1	4.1	0.0	35.4	34.8	53.9	18.5	19.1
3	5725.00	30.5	30.5	31.9	31.1	4.2	0.0	35.5	35.5	53.9	18.4	18.4
<b>Test distance 1meters RESULT=Reading + ANT Factor - Amp Gain + Cable Loss + Filter Loss - Dfac</b>												
4	11519.40	35.4	36.8	39.7	32.4	6.4	0.6	40.2	41.6	53.9	13.7	12.3
5	17225.60	33.9	35.0	42.7	31.1	7.5	0.6	44.1	45.2	53.9	9.8	8.7
6	23038.80	36.0	36.0	38.7	31.4	8.8	0.7	43.3	43.3	53.9	10.6	10.6
<b>Test distance 0.5meters RESULT=Reading + ANT Factor - Amp Gain + Cable Loss + Filter Loss - Dfac</b>												
7	34451.19	32.1	32.4	40.5	28.2	16.5	0.0	45.3	45.6	53.9	8.6	8.3

Test Distance 1.0m : Distance Factor(Dfac) = 20log(3/1.0) = 9.54 dB  
Test Distance 0.5m : Distance Factor(Dfac) = 20log(3/0.5) = 15.56 dB  
Test Distance 0.2m : Distance Factor(Dfac) = 20log(3/0.2) = 23.52 dB

\*Except for the above table : All other spurious emissions were less than 20dB for the limit.  
\*The result is rounded off to the second decimal place. Therefore, there may be 0.1 difference for the result.  
\*Hi-Pass Fiter was not used for factor 0.0dB of the above table.

**Radiated Spurious Emission (above 1GHz)**  
(Tx, Ant1, Mid)

UL Japan , Inc.

Company : Panasonic Communications Co., Ltd.  
Equipment : Cordless Telephone (Base)  
Model : KX-TG4321  
S/N : Air001  
Power : DC3.6V  
Mode : Tx Mid 5798.053MHz  
Position : H: X-axis, V: Y-axis, Worst Ant: Ant1

Head Office EMC Lab. No.4 & 3 Semi Anechoic Chamber  
Regulation : FCC15.247(d)  
Test Distance : 3m / 1m / 0.5m  
Date : 10/01/2007, 10/02/2007  
Temperature : 25 deg.C. , 25deg.C.  
Humidity : 52 % , 52%  
Engineer : Tomotaka Sasagawa

**PK DETECT** (RBW: 1MHz, VBW: 1MHz)

No.	FREQ [MHz]	S/A READING		ANT Factor [dB/m]	AMP GAIN [dB]	CABLE LOSS [dB]	Hi-Pass Filter [dB]	RESULT		Limit PK [dBuV/m]	MARGIN	
		HOR	VER					HOR	VER		HOR	VER
		[dBuV]						[dBuV/m]		[dB]		
<b>Test distance 3meters RESULT=Reading + ANT Factor - Amp Gain + Cable Loss + Filter Loss</b>												
1	4348.26	59.6	60.4	29.7	31.2	3.8	0.0	61.9	62.7	73.9	12.0	11.2
2	5460.00	46.5	43.2	31.5	31.1	4.1	0.0	51.0	47.7	73.9	22.9	26.2
3	5850.00	43.0	41.2	32.0	31.0	4.2	0.0	48.2	46.4	73.9	25.7	27.5
<b>Test distance 1meters RESULT=Reading + ANT Factor - Amp Gain + Cable Loss + Filter Loss - Dfac</b>												
4	11596.11	49.3	54.5	39.6	32.4	6.5	0.5	54.0	59.2	73.9	19.9	14.7
5	17394.16	45.9	48.2	43.7	31.0	7.5	0.6	57.2	59.5	73.9	16.7	14.4
6	23192.19	40.9	41.2	38.7	31.3	8.9	0.7	48.4	48.7	73.9	25.5	25.2
<b>Test distance 0.5meters RESULT=Reading + ANT Factor - Amp Gain + Cable Loss + Filter Loss - Dfac</b>												
7	34788.32	41.2	42.5	40.6	28.1	16.5	0.0	54.6	55.9	73.9	19.3	18.0

**AV DETECT** (RBW: 1MHz, VBW: 10Hz)

No.	FREQ [MHz]	S/A READING		ANT Factor [dB/m]	AMP GAIN [dB]	CABLE LOSS [dB]	Hi-Pass Filter [dB]	RESULT		Limit AV [dBuV/m]	MARGIN	
		HOR	VER					HOR	VER		HOR	VER
		[dBuV]						[dBuV/m]		[dB]		
<b>Test distance 3meters RESULT=Reading + ANT Factor - Amp Gain + Cable Loss + Filter Loss</b>												
1	4348.26	34.8	35.1	29.7	31.2	3.8	0.0	37.1	37.4	53.9	16.8	16.5
2	5460.00	30.2	31.2	31.5	31.1	4.1	0.0	34.7	35.7	53.9	19.2	18.2
3	5850.00	30.4	30.7	32.0	31.0	4.2	0.0	35.6	35.9	53.9	18.3	18.0
<b>Test distance 1meters RESULT=Reading + ANT Factor - Amp Gain + Cable Loss + Filter Loss - Dfac</b>												
4	11596.11	34.6	36.4	39.6	32.4	6.5	0.5	39.3	41.1	53.9	14.6	12.8
5	17394.16	34.1	34.0	43.7	31.0	7.5	0.6	45.4	45.3	53.9	8.5	8.6
6	23192.19	30.2	30.4	38.7	31.3	8.9	0.7	37.7	37.9	53.9	16.2	16.0
<b>Test distance 0.5meters RESULT=Reading + ANT Factor - Amp Gain + Cable Loss + Filter Loss - Dfac</b>												
7	34788.32	32.3	32.1	40.6	28.1	16.5	0.0	45.7	45.5	53.9	8.2	8.4

Test Distance 1.0m : Distance Factor(Dfac) = 20log(3/1.0) = 9.54 dB

Test Distance 0.5m : Distance Factor(Dfac) = 20log(3/0.5) = 15.56 dB

Test Distance 0.2m : Distance Factor(Dfac) = 20log(3/0.2) = 23.52 dB

\*Except for the above table : All other spurious emissions were less than 20dB for the limit.

\*The result is rounded off to the second decimal place. Therefore, there may be 0.1 difference for the result.

\*Hi-Pass Fiter was not used for factor 0.0dB of the above table.

**UL Japan, Inc.**

**Head Office EMC Lab.**

4383-326 Asama-cho, Ise-shi, Mie-ken 516-0021 JAPAN

Telephone : +81 596 24 8116

Facsimile : +81 596 24 8124

**Radiated Spurious Emission (above 1GHz)**  
(Tx, Ant1, High)

UL Japan , Inc.

Company : Panasonic Communications Co., Ltd.  
Equipment : Cordless Telephone (Base)  
Model : KX-TG4321  
S/N : Air001  
Power : DC3.6V  
Mode : Tx High 5838.185MHz  
Position : H: X-axis, V: Y-axis, Worst Ant: Ant1

Head Office EMC Lab. No.4 & 3 Semi Anechoic Chamber  
Regulation : FCC15.247(d)  
Test Distance : 3m / 1m / 0.5m  
Date : 10/01/2007, 10/02/2007  
Temperature : 25 deg.C. , 25deg.C.  
Humidity : 52 % , 52%  
Engineer : Tomotaka Sasagawa

**PK DETECT** (RBW: 1MHz, VBW: 1MHz)

No.	FREQ [MHz]	S/A READING		ANT Factor [dB/m]	AMP GAIN [dB]	CABLE LOSS [dB]	Hi-Pass Filter [dB]	RESULT		Limit PK [dBuV/m]	MARGIN	
		HOR	VER					HOR	VER		HOR	VER
		[dBuV]						[dBuV/m]		[dB]		
<b>Test distance 3meters RESULT=Reading + ANT Factor - Amp Gain + Cable Loss + Filter Loss</b>												
1	4378.48	60.6	58.5	29.8	31.2	3.2	0.0	62.4	60.3	73.9	11.5	13.6
2	5460.00	41.8	41.2	31.5	31.1	3.5	0.0	45.7	45.1	73.9	28.2	28.8
3	5725.00	43.1	42.1	31.9	31.1	3.6	0.0	47.5	46.5	73.9	26.4	27.4
4	5850.00	45.0	51.9	32.0	31.0	3.7	0.0	49.7	56.6	73.9	24.2	17.3
<b>Test distance 1meters RESULT=Reading + ANT Factor - Amp Gain + Cable Loss + Filter Loss - Dfac</b>												
5	11676.37	47.7	49.3	39.5	32.4	6.5	0.5	52.3	53.9	73.9	21.6	20.0
6	17514.56	45.1	48.4	44.7	31.0	7.6	0.6	57.5	60.8	73.9	16.4	13.1
7	23352.75	41.2	42.1	38.7	31.1	9.0	0.8	49.1	50.0	73.9	24.8	23.9
<b>Test distance 0.5meters RESULT=Reading + ANT Factor - Amp Gain + Cable Loss + Filter Loss - Dfac</b>												
8	35029.11	41.2	42.1	40.8	28.0	16.6	0.0	55.0	55.9	73.9	18.9	18.0

**AV DETECT** (RBW: 1MHz, VBW: 10Hz)

No.	FREQ [MHz]	S/A READING		ANT Factor [dB/m]	AMP GAIN [dB]	CABLE LOSS [dB]	Hi-Pass Filter [dB]	RESULT		Limit AV [dBuV/m]	MARGIN	
		HOR	VER					HOR	VER		HOR	VER
		[dBuV]						[dBuV/m]		[dB]		
<b>Test distance 3meters RESULT=Reading + ANT Factor - Amp Gain + Cable Loss + Filter Loss</b>												
1	4378.48	34.0	35.4	29.8	31.2	3.2	0.0	35.8	37.2	53.9	18.1	16.7
2	5460.00	30.8	30.9	31.5	31.1	3.5	0.0	34.7	34.8	53.9	19.2	19.1
3	5725.00	31.2	30.9	31.9	31.1	3.6	0.0	35.6	35.3	53.9	18.3	18.6
4	5850.00	32.1	33.5	32.0	31.0	3.7	0.0	36.8	38.2	53.9	17.1	15.7
<b>Test distance 1meters RESULT=Reading + ANT Factor - Amp Gain + Cable Loss + Filter Loss - Dfac</b>												
5	11676.37	31.2	31.2	39.5	32.4	6.5	0.5	35.8	35.8	53.9	18.1	18.1
6	17514.56	34.4	34.2	44.7	31.0	7.6	0.6	46.8	46.6	53.9	7.1	7.3
7	23352.75	31.2	30.9	38.7	31.1	9.0	0.8	39.1	38.8	53.9	14.8	15.1
<b>Test distance 0.5meters RESULT=Reading + ANT Factor - Amp Gain + Cable Loss + Filter Loss - Dfac</b>												
8	35029.11	32.5	32.1	40.8	28.0	16.6	0.0	46.3	45.9	53.9	7.6	8.0

Test Distance 1.0m : Distance Factor(Dfac) = 20log(3/1.0) = 9.54 dB  
Test Distance 0.5m : Distance Factor(Dfac) = 20log(3/0.5) = 15.56 dB  
Test Distance 0.2m : Distance Factor(Dfac) = 20log(3/0.2) = 23.52 dB

\*Except for the above table : All other spurious emissions were less than 20dB for the limit.

\*The result is rounded off to the second decimal place. Therefore, there may be 0.1 difference for the result.

\*Hi-Pass Fiter was not used for factor 0.0dB of the above table.

**UL Japan, Inc.**

**Head Office EMC Lab.**

4383-326 Asama-cho, Ise-shi, Mie-ken 516-0021 JAPAN

Telephone : +81 596 24 8116

Facsimile : +81 596 24 8124

**Radiated Spurious Emission (above 1GHz)**  
(Rx, Ant1, Mid)

Company : Panasonic Communications Co., Ltd.	UL Japan , Inc.
Equipment : Cordless Telephone (Base)	Head Office EMC Lab. No.4 & 3 Semi Anechoic Chamber
Model : KX-TG4321	Regulation : FCC15.247(d)
S/N : Air001	Test Distance : 3m / 1m / 0.5m
Power : DC3.6V	Date : 10/01/2007, 10/02/2007
Mode : Rx Mid 5798.053MHz	Temperature : 25 deg.C. , 25deg.C.
Position : H: X-axis, V: Y-axis, Worst Ant: Ant1	Humidity : 52 % , 52%
	Engineer : Tomotaka Sasagawa

**PK DETECT** (RBW: 1MHz, VBW: 1MHz)

No.	FREQ [MHz]	S/A READING		ANT Factor [dB/m]	AMP GAIN [dB]	CABLE LOSS [dB]	Hi-Pass Filter [dB]	RESULT		Limit PK [dBuV/m]	MARGIN	
		HOR	VER					HOR	VER		HOR	VER
Test distance 3meters RESULT=Reading + ANT Factor - Amp Gain + Cable Loss + Filter Loss												
1	5798.05	41.8	42.1	32.0	31.1	4.2	0.0	46.9	47.2	73.9	27.0	26.7
Test distance 1meters RESULT=Reading + ANT Factor - Amp Gain + Cable Loss + Filter Loss - Dfac												
2	17394.16	46.1	45.9	43.7	31.0	7.5	0.0	56.8	56.6	73.9	17.1	17.3

**AV DETECT** (RBW: 1MHz, VBW: 10Hz)

No.	FREQ [MHz]	S/A READING		ANT Factor [dB/m]	AMP GAIN [dB]	CABLE LOSS [dB]	Hi-Pass Filter [dB]	RESULT		Limit AV [dBuV/m]	MARGIN	
		HOR	VER					HOR	VER		HOR	VER
Test distance 3meters RESULT=Reading + ANT Factor - Amp Gain + Cable Loss + Filter Loss												
1	5798.05	30.8	31.2	32.0	31.1	4.2	0.0	35.9	36.3	53.9	18.0	17.6
Test distance 1meters RESULT=Reading + ANT Factor - Amp Gain + Cable Loss + Filter Loss - Dfac												
2	17394.16	34.0	33.5	43.7	31.0	7.5	0.0	44.7	44.2	53.9	9.2	9.7

Test Distance 1.0m : Distance Factor(Dfac) = 20log(3/1.0) = 9.54 dB  
Test Distance 0.5m : Distance Factor(Dfac) = 20log(3/0.5) = 15.56 dB  
Test Distance 0.2m : Distance Factor(Dfac) = 20log(3/0.2) = 23.52 dB

\*Except for the above table : All other spurious emissions were less than 20dB for the limit.  
\*The result is rounded off to the second decimal place. Therefore, there may be 0.1 difference for the result.  
\*Hi-Pass Fiter was not used for factor 0.0dB of the above table.

\*In the frequency over the fifth harmonic, the noise from the EUT was not seen.The data above is its base noise.

**Conducted Spurious Emission**  
**Ch:Low**

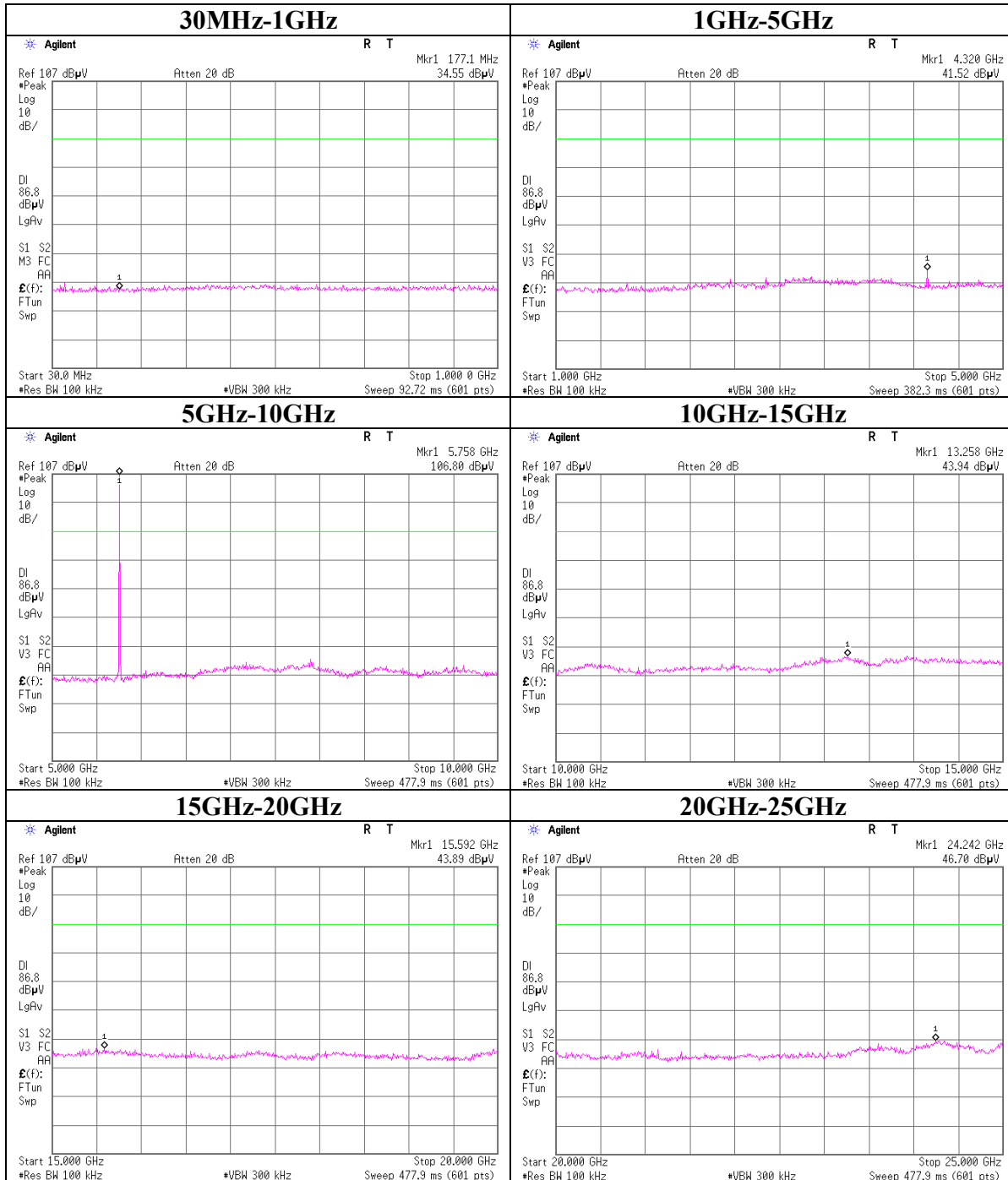

**Conducted Spurious Emission**  
**Ch:Low**

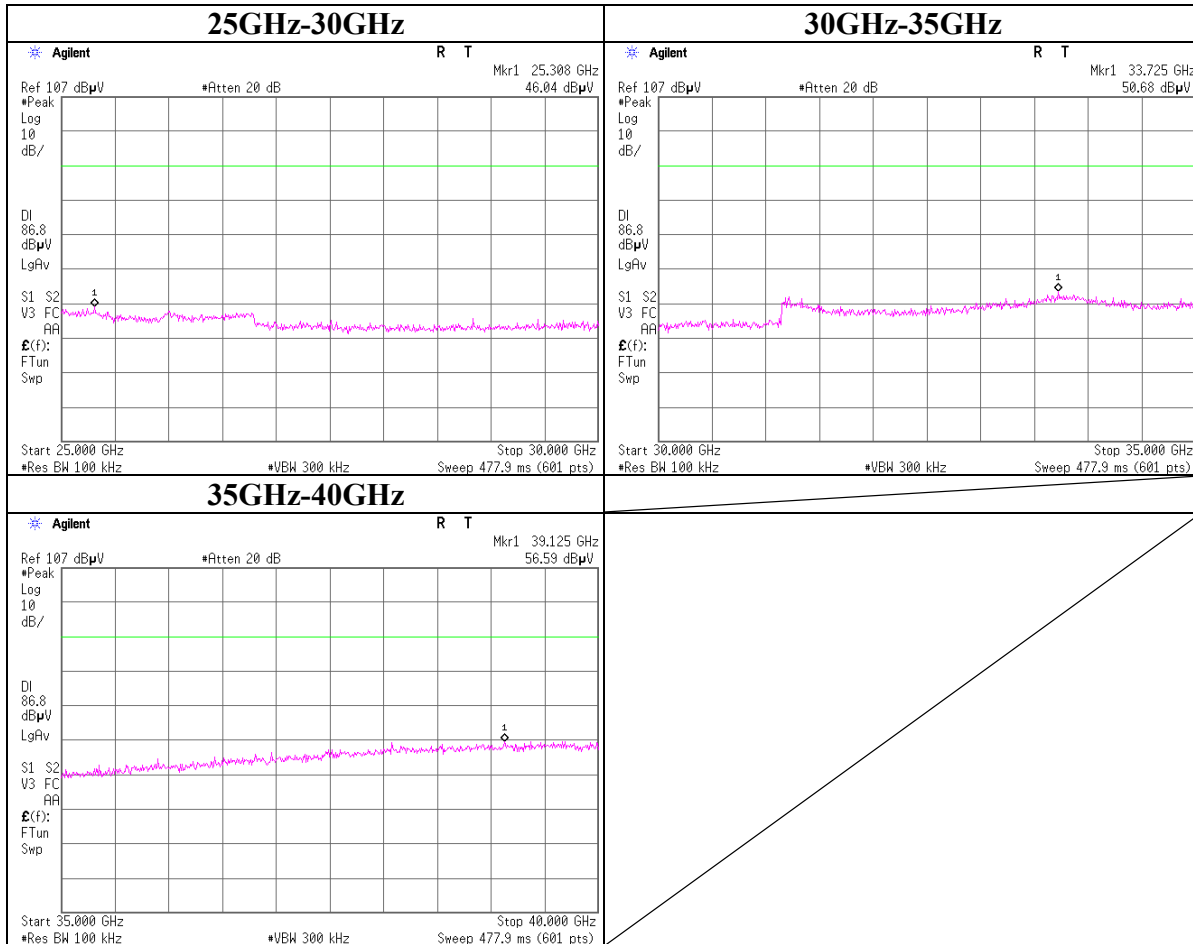

**Conducted Spurious Emission**  
**Ch:Mid**

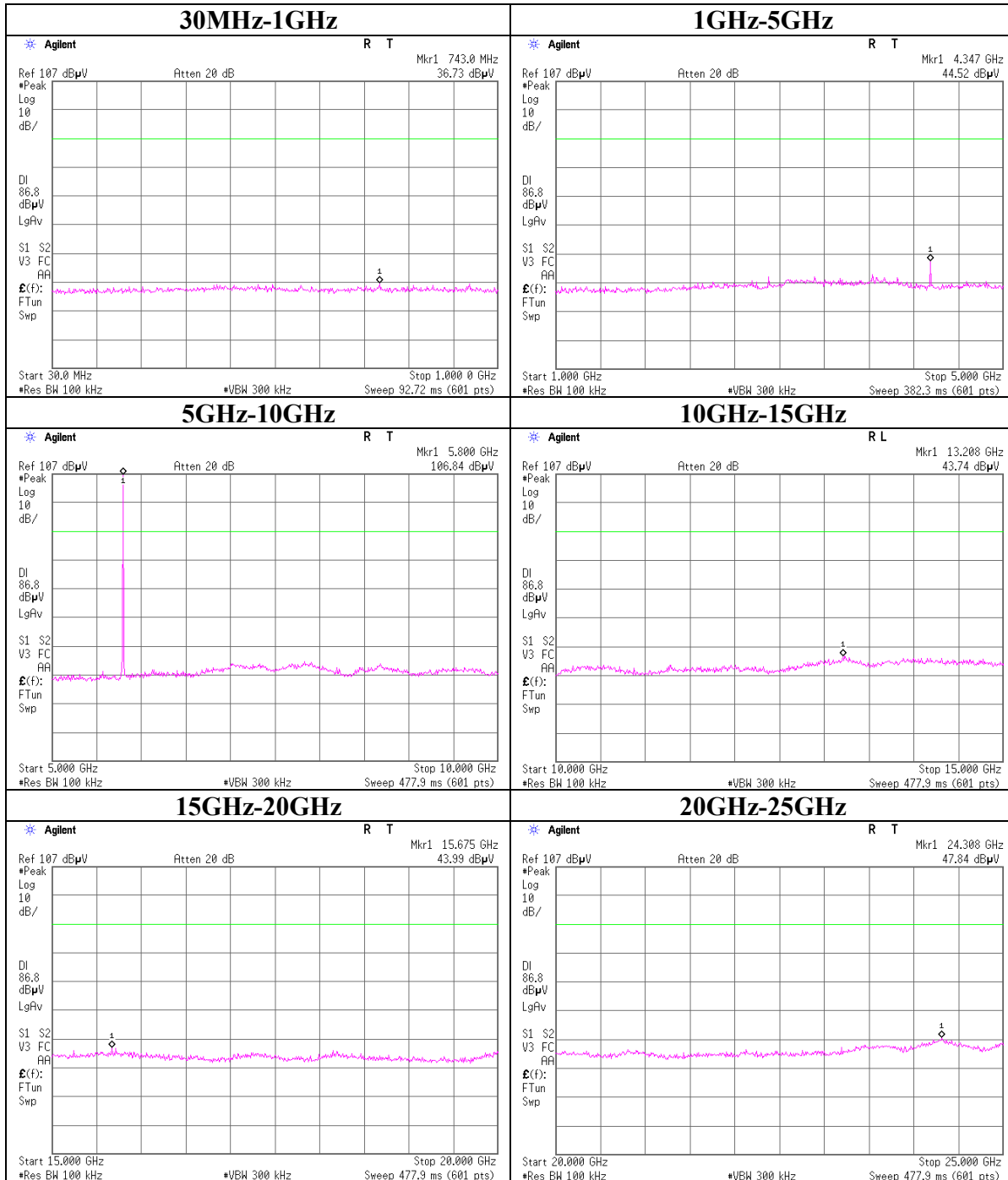

**Conducted Spurious Emission**  
**Ch:Mid**

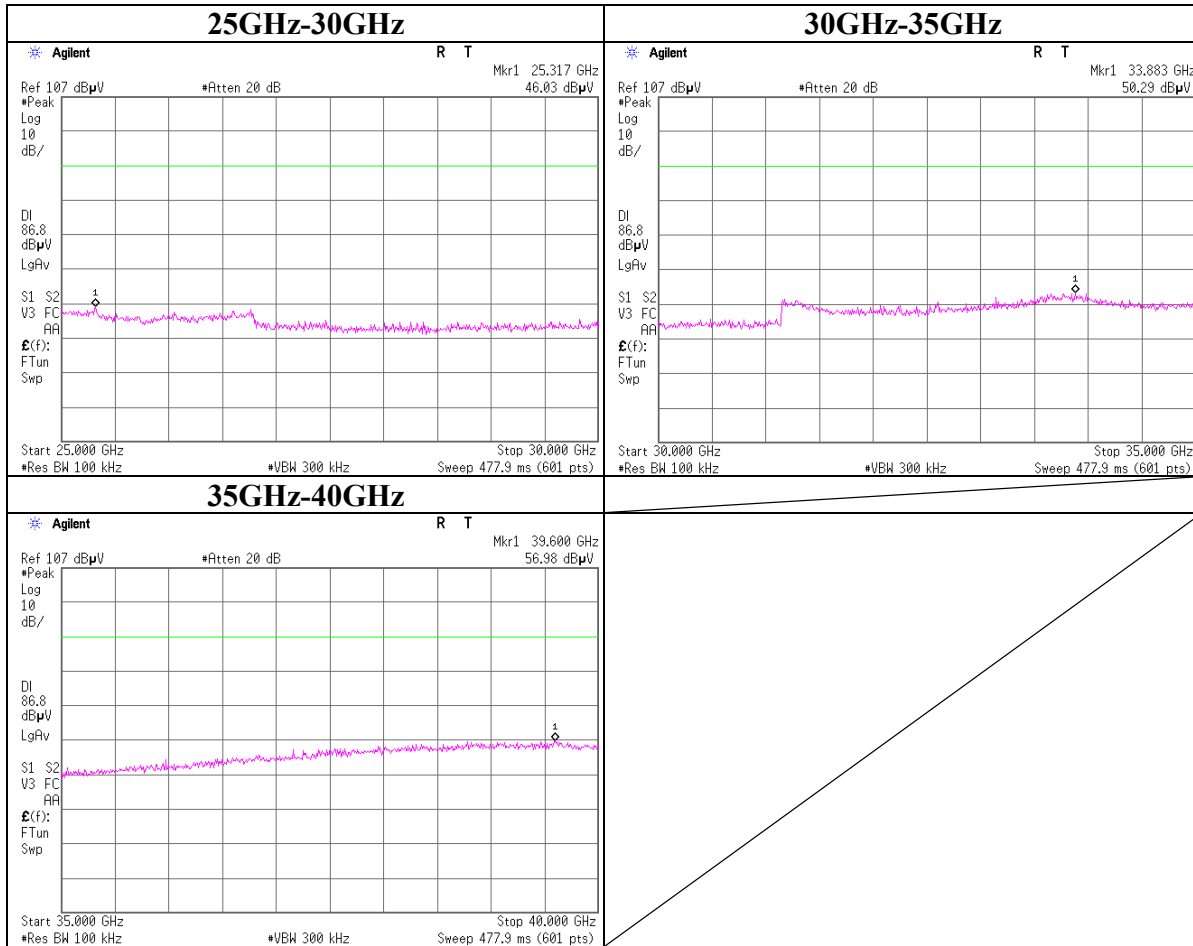

**Conducted Spurious Emission**  
**Ch:High**

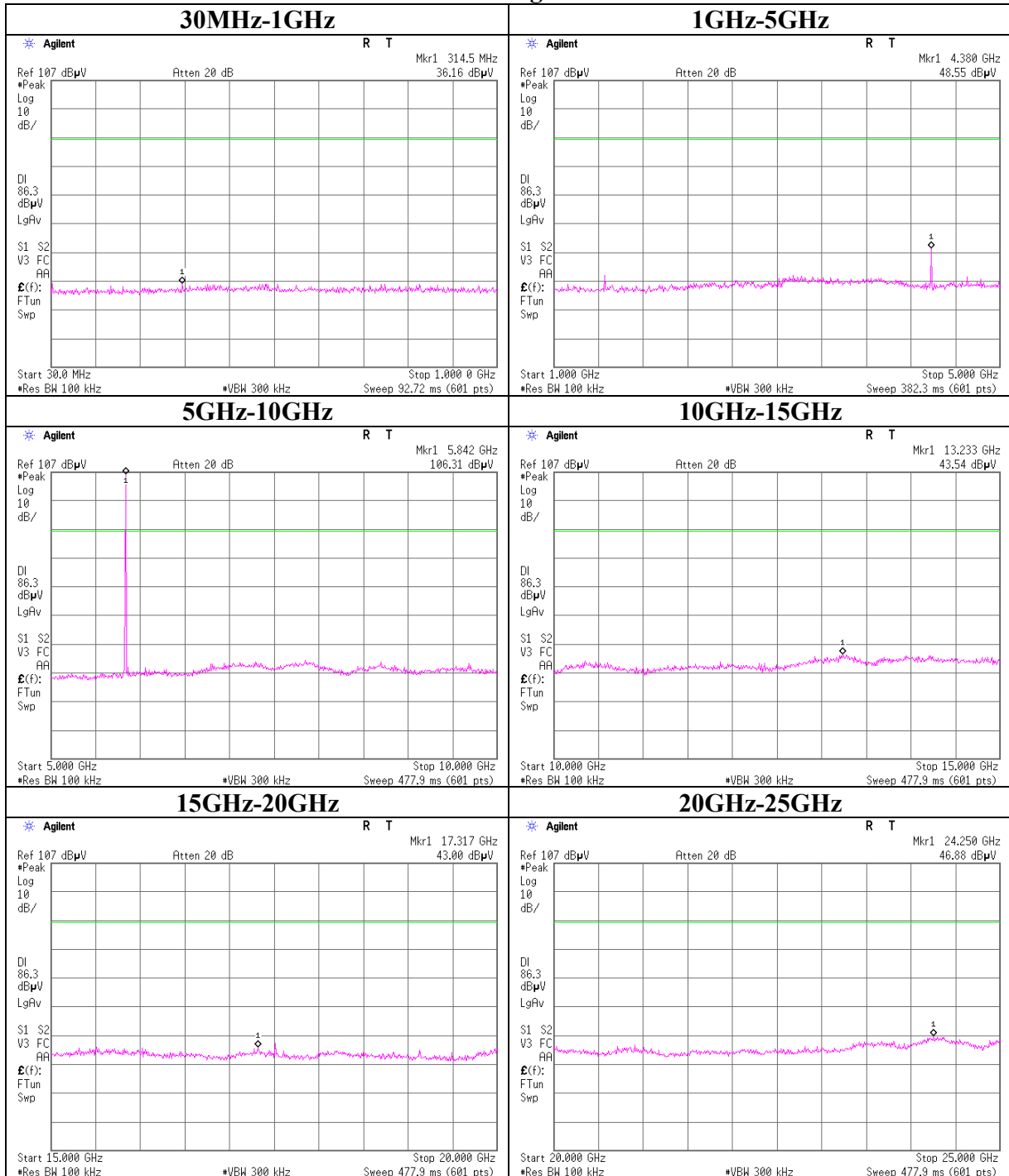

**Conducted Spurious Emission**  
**Ch:High**

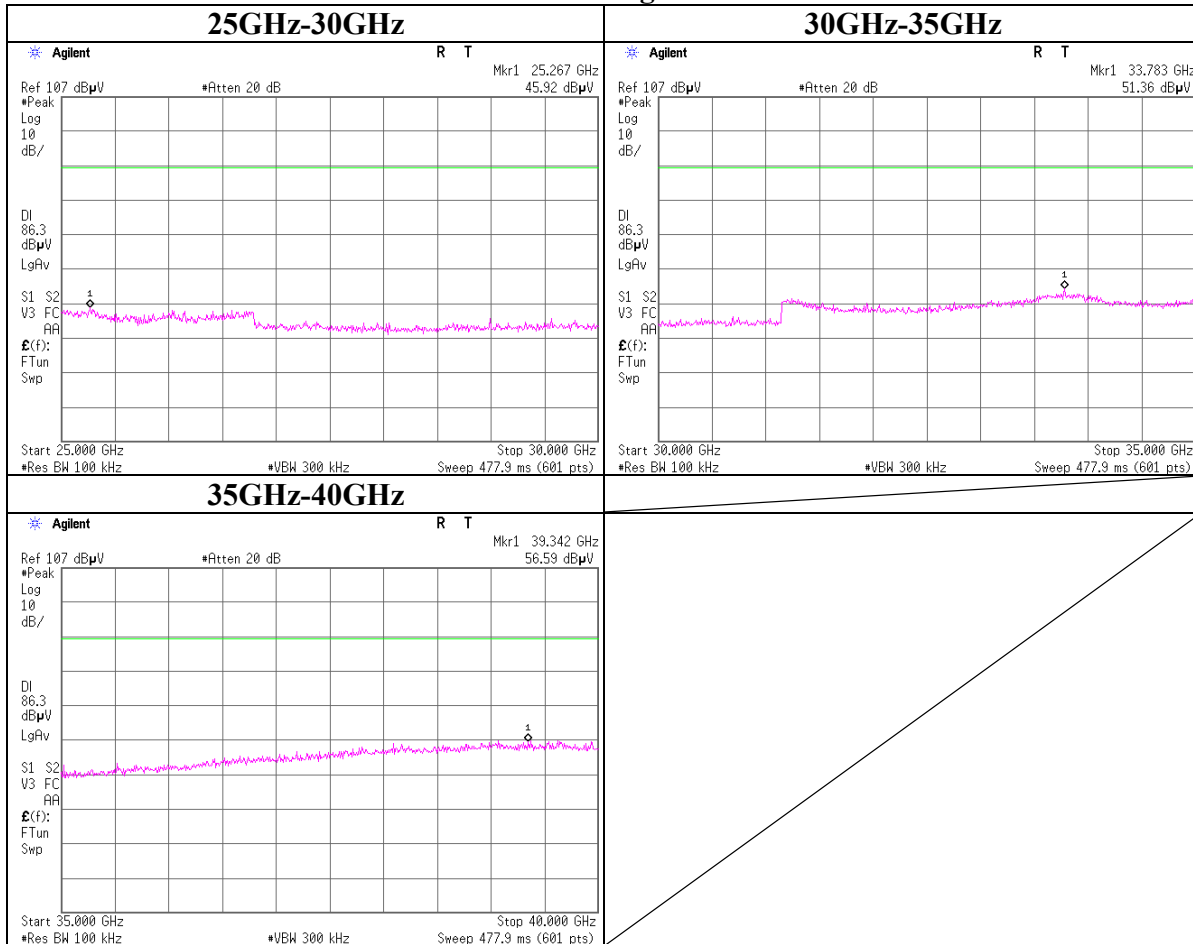

**Conducted Spurious Emission**  
**Ch:Mid(Rx)**

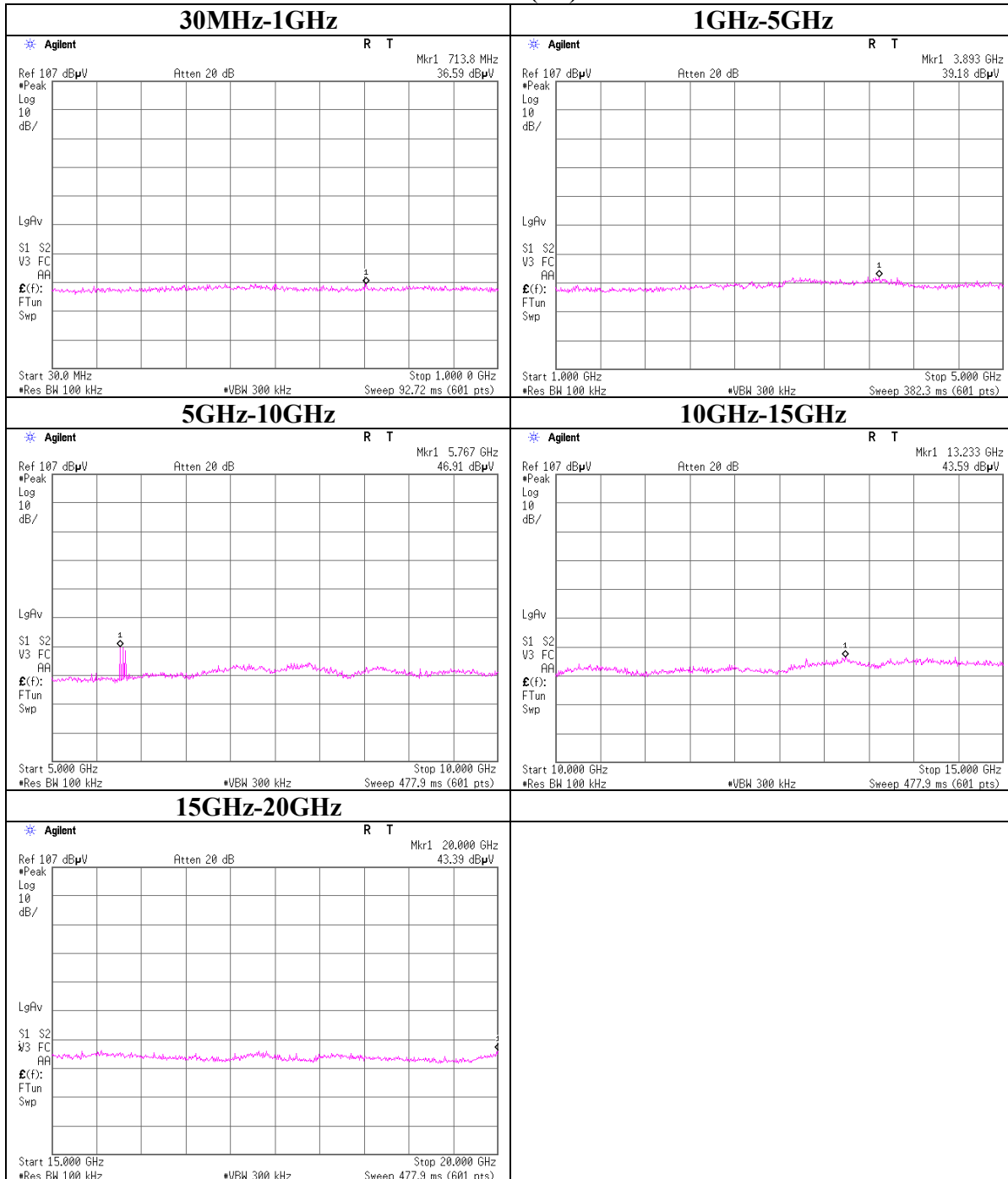

### Conducted Spurious Emission Band Edge compliance

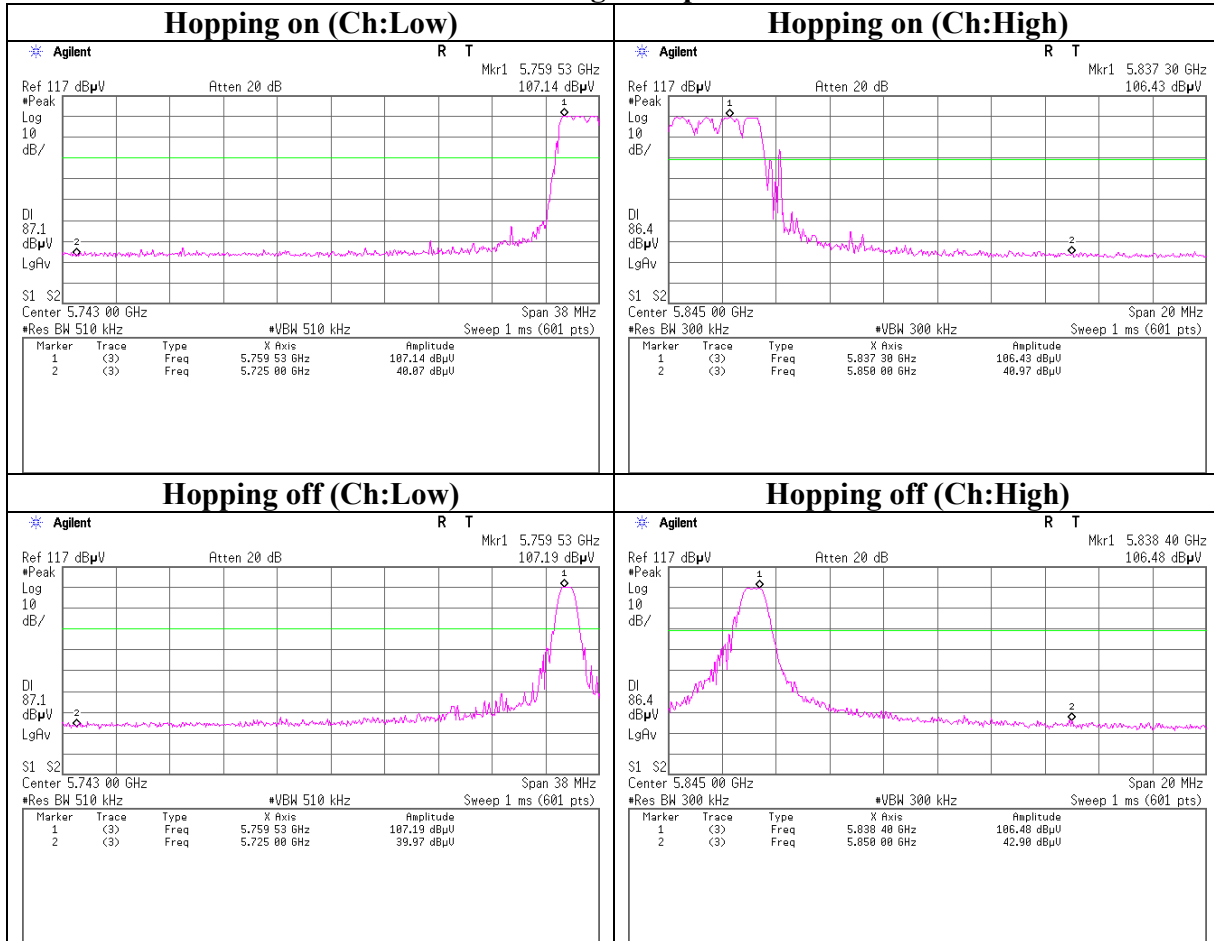

### 99% Occupied Bandwidth

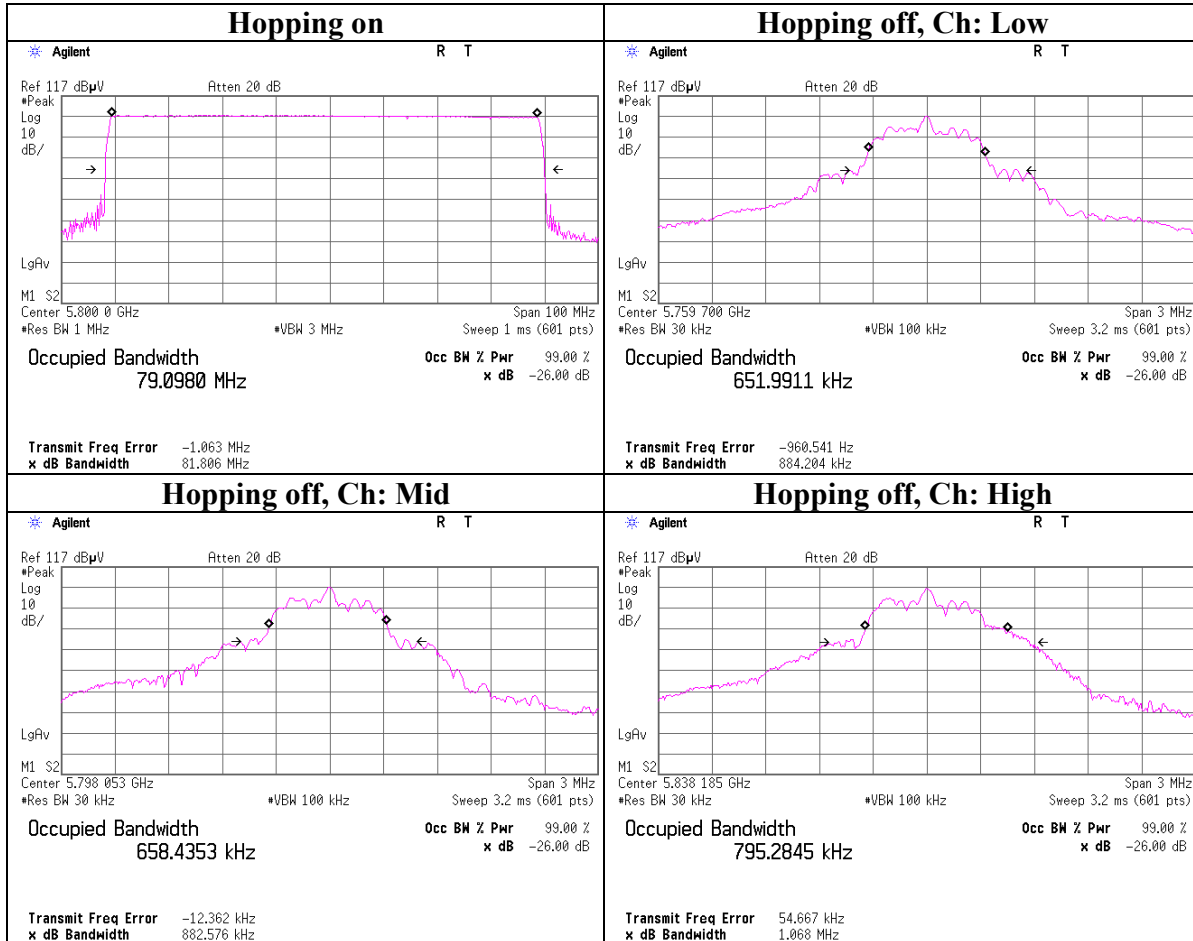

### **APPENDIX 3:Test instruments**

#### **EMI test equipment (1/2)**

<b>Control No.</b>	<b>Instrument</b>	<b>Manufacturer</b>	<b>Model No</b>	<b>Test Item</b>	<b>Calibration Date * Interval(month)</b>
MPM-08	Power Meter	Anritsu	ML2495A	AT	2007/09/12 * 12
MPSE-11	Power sensor	Anritsu	MA2411B	AT	2007/09/12 * 12
MAT-21	Attenuator(20dB)(above1GHz)	HIROSE ELECTRIC CO.,LTD.	AT-120	AT	2007/01/11 * 12
MCC-06	Microwave Cable 1G-26.5GHz 1m	Suhner	SUCOFLEX 104	AT	2007/02/26 * 12
MSA-10	Spectrum Analyzer	Agilent	E4448A	AT	2007/07/04 * 12
MOS-04	Digital Humidity Indicator	N.T	NT-1800	AT	2006/11/27 * 12
MCC-65	Microwave Cable 1G-40GHz	Schner	SUCOFLEX102	AT	2007/04/03 * 12
MAEC-04	Anechoic Chamber	TDK	Semi Anechoic Chamber 3m	RE	2007/03/03 * 12
MHA-21	Horn Antenna 1-18GHz	Schwarzbeck	BBHA9120D	RE	2007/08/16 * 12
MCC-57	Microwave Cable 1G-26.5GHz	Suhner	SUCOFLEX104	RE	2007/03/30 * 12
MPA-12	MicroWave System Amplifier	Agilent	83017A	RE	2007/03/12 * 12
MSA-05	Spectrum Analyzer	Advantest	R3273	RE	2007/06/01 * 12
MSTW-14	EMI measurement program	TSJ	TEPTO-DV	RE	-
MOS-14	Thermo-Hygrometer	Custom	CTH-180	RE	2006/01/19 * 24
MHF-11	High Pass Filter 7-30GHz	TOKIMEC	TF37NCCC	RE	2007/06/26 * 12
MHA-16	Horn Antenna 15-40GHz	Schwarzbeck	BBHA9170	RE	2007/04/06 * 12
MHA-20	Horn Antenna 1-18GHz	Schwarzbeck	BBHA9120D	RE	2007/04/14 * 12
MCC-56	Microwave Cable 1G-26.5GHz	Suhner	SUCOFLEX104	RE	2007/03/29 * 12
MPA-11	MicroWave System Amplifier	Agilent	83017A	RE	2007/03/02 * 12
MPA-13	Pre Amplifier	SONOMA INSTRUMENT	310	RE	2007/03/16 * 12
MPA-17	Pre Amplifier	UNITEK ELECTROBICS INC.	40GHzAMP	RE	2006/12/15 * 12
MCC-51	Coaxial cable	UL Japan	-	RE / CE	2007/07/26 * 12
MAT-30	Attenuator(6dB)	TME	UFA-01	RE	2007/03/05 * 12
MBA-03	Biconical Antenna	Schwarzbeck	BBA9106	RE	2007/01/19 * 12
MLA-03	Logperiodic Antenna	Schwarzbeck	USLP9143	RE	2007/01/19 * 12
MOS-12	Thermo-Hygrometer	Custom	CTH-180	RE	2006/01/19 * 24
MSA-09	Spectrum Analyzer	Advantest	R3273	RE	2006/12/08 * 12
MTR-02	Test Receiver	Rohde & Schwarz	ESCS30	RE	2007/02/03 * 12
MJM-06	Measure	PROMART	SEN1955	RE	-

**UL Japan, Inc.**

**Head Office EMC Lab.**

4383-326 Asama-cho, Ise-shi, Mie-ken 516-0021 JAPAN

Telephone : +81 596 24 8116

Facsimile : +81 596 24 8124

**EMI test equipment (2/2)**

Control No.	Instrument	Manufacturer	Model No	Test Item	Calibration Date * Interval(month)
MAEC-03	Anechoic Chamber	TDK	Semi Anechoic Chamber 3m	RE / CE	2007/03/05 * 12
MSA-03	Spectrum Analyzer	Agilent	E4448A	RE	2007/09/05 * 12
MCC-53	Microwave Cable 1G-40GHz	Suhner	SUCOFLEX101	RE	2007/03/08 * 12
MOS-12	Thermo- Hygrometer	Custom	CTH-180	RE / CE	2006/01/19 * 24
MLS-06	LISN(AMN)	Schwarzbeck	NSLK8127	CE (EUT)	2007/02/22 * 12
MLS-07	LISN(AMN)	Schwarzbeck	NSLK8127	CE (AE)	2007/02/22 * 12
MJM-06	Measure	PROMART	SEN1955		-

The expiration date of the calibration is the end of the expired month.

All equipment is calibrated with traceable calibrations. Each calibration is traceable to the national or international standards.

**Test Item:**

**CE: Conducted Emission test**

**RE: Radiated Spurious Emission test**

**AT: Antenna Terminal Conducted test**

---

**UL Japan, Inc.**

**Head Office EMC Lab.**

4383-326 Asama-cho, Ise-shi, Mie-ken 516-0021 JAPAN

Telephone : +81 596 24 8116

Facsimile : +81 596 24 8124