

## **EMC** EMISSION - TEST REPORT

JQA APPLICATION No. : KL80010466

Name of Product : 2.4GHz Frequency Hopping Spread Spectrum Cordless Telephone  
(Base Unit)

Model/Type No. : KX-TG2730

FCC ID : ACJ96NKX-TG2730

Applicant : Kyushu Matsushita Electric Co., Ltd.

Address : 1-62, 4-chome, Minoshima, Hakata-ku, Fukuoka 812-8531, Japan

Manufacturer : Kyushu Matsushita Electric Co., Ltd.

Address : 1-62, 4-chome, Minoshima, Hakata-ku, Fukuoka 812-8531, Japan

Receive date of EUT : December 3, 2001

**Final Judgement** : **Passed**

**TEST RESULTS IN THIS REPORT** are obtained in use of equipment that is traceable to National Institute of Advanced Industrial Science and Technology (AIST) under METI Japan and Communications Research Lab. (CRL) under MPHPT Japan.

**THE TEST RESULTS** only responds to the test sample. This test report shall not be reproduced except in full.

## DIRECTORY

	<b>Page</b>
<b>A) Documentation</b>	
Directory	<u>2</u>
Test Regulation / General Information	<u>3 - 5</u>
Test Conditions	<u>6 - 13</u>
Configuration of EUT / Operation mode of the EUT	<u>14 - 15</u>
EUT Modification / Responsible Party / Deviation from Standard	<u>16</u>
Test results / Measurement Uncertainty	<u>17 - 19</u>
Summary	<u>20</u>
<b>Test System-Arrangement (Drawings)</b>	<u>21</u>
<b>Preliminary Test and Test-setup (Drawings)</b>	<u>22 - 25</u>
<b>Test-setup (Photographs) at worst case</b>	<u>26</u>
<b>B) Test data</b>	
Conducted Emission	450 kHz - 30 MHz <u>27</u>
Electromagnetic Field Radiated Emission	9 kHz - 25 GHz <u>28 - 32</u>
Maximum Peak Power (EIRP)	<u>33</u>
Transmitter Power (TP)	<u>34</u>
Antenna Gain of the EUT	<u>35</u>
-20dB Bandwidth and Band-edge Emission	<u>36 - 41</u>
Carrier Frequencies Separation	<u>42 - 43</u>
Channel Separation / Dwell Time	<u>44 - 45</u>

## TEST REGULATION

FCC Rules and Regulations Part 15 Subpart A and C (February 28, 2001)

- Class A Digital Device
- Class B Digital Device
- Intentional Radiator (Sec.15.247)
- Receiver

### **Test items:**

- Sec.15.203 : Antenna requirement
- Sec.15.205 : Restricted bands of operation
- Sec.15.207 : Conducted limits
- Sec.15.209 : Radiated emission limits general requirements
- Sec.15.214 : Cordless Telephones
- Sec.15.247 : Operation within the bands 902-928MHz, 2400-2483.5MHz, 5725-5875MHz, and 24.0-24.25GHz

### **Test procedure:**

Conducted emission and radiated emission test were performed according to the procedures in ANSI C63.4-1992.

## GENERAL INFORMATION

### **Test facility:**

- 1) Test Facility located at Kita-Kansai : 1st and 2nd Open Sites (3 m Site)  
Test Facility located at Kameoka : 1st Open Site (3, 10 and 30 m, on common plane)  
: 2nd Open Site (3 and 10 m, on common plane)

**FCC filing No. : 31040/SIT 1300F2**

- 2) KITA-KANSAI TESTING CENTER is recognized under the National Voluntary Laboratory Accreditation Program for satisfactory compliance established in Title 15, Part 285 Code of Federal Regulations.

**NVLAP Lab Code: 200191-0**

- 3) Average Measurement Method  
**FCC filing No. : 950523A 1300F2**

### **Definitions for symbols used in this test report:**

- Black box indicates that the listed condition, standard or equipment is applicable for this Report.
- Blank box indicates that the listed condition, standard or equipment is not applicable for this Report.

**Description of the Equipment Under Test (EUT):**

- 1) Name : 2.4GHz Frequency Hopping Spread Spectrum Cordless Telephone (Base Unit)
- 2) Model/Type No. : KX-TG2730
- 3) Product Type : Pre-Production
- 4) Category : Intentional Radiator
- 5) EUT Authorization :  - Verification  - Certification  - D.o.C.
- 6) Transmitting Frequency : 2400.916645 MHz (01ch) - 2480.293161 MHz (90ch)
- 7) Receiving Frequency : 2400.916645 MHz (01ch) - 2480.293161 MHz (90ch)
- 8) Method/System : Frequency Hopping Spread Spectrum (FHSS)
- 9) Type of Antenna : Collinear Antenna
- 10) Antenna Gain : 4 dBi
- 11) Measured MAX Output Power : 66 mW (EIRP)
- 12) Power Rating : AC 120V 60Hz 1 $\phi$  2-pin plug (AC Adapter : PQLV10)

**Detailed Transmitter portion (Channel plan):**

Transmitting frequency : 2400.916645 MHz (01ch) - 2480.293161 MHz (90ch)  
Number of channel : 90  
Channel Separation : 891.871 kHz

CH	0	1	2	3	4	5	6	7	8	9
0	--	2400.916645	2401.808516	2402.700387	2403.592258	2404.484129	2405.376000	2406.267871	2407.159742	2408.051613
10	2408.943484	2409.835355	2410.727226	2411.619097	2412.510968	2413.402839	2414.294710	2415.186581	2416.078452	2416.970323
20	2417.862194	2418.754065	2419.645935	2420.537806	2421.429677	2422.321548	2423.213419	2424.105290	2424.997161	2425.889032
30	2426.780903	2427.672774	2428.564645	2429.456516	2430.348387	2431.240258	2432.132129	2433.024000	2433.915871	2434.807742
40	2435.699613	2436.591484	2437.483355	2438.375226	2439.267097	2440.158968	2441.050839	2441.942710	2442.834581	2443.726452
50	2444.618323	2445.510194	2446.402065	2447.293935	2448.185806	2449.077677	2449.969548	2450.861419	2451.753290	2452.645161
60	2453.537032	2454.428903	2455.320774	2456.212645	2457.104516	2457.996387	2458.888258	2459.780129	2460.672000	2461.563871
70	2462.455742	2463.347613	2464.239484	2465.131355	2466.023226	2466.915097	2467.806968	2468.698839	2469.590710	2470.482581
80	2471.374452	2472.266323	2473.158194	2474.050065	2474.941935	2475.833806	2476.725677	2477.617548	2478.509419	2479.401290
90	2480.293161	--	--	--	--	--	--	--	--	--

**Modulation System Information:**

Spread Spectrum Method : Frequency Hopping  
Modulation : GFSK (Gaussian-shaped Binary Frequency Shift Keying)  
Hop Rate : 100 hops/sec.  
Bit Rate : 576 kBit/sec.  
Digital Security Code : 40 Bit

**Detailed Receiver portion:**

Receiving frequency : 2400.916645 MHz (01ch) - 2480.293161 MHz (90ch)  
Local frequency : 2390.214194 MHz (01ch) - 2469.590710 MHz (90ch)  
Intermediate frequency : 10.702 MHz

**Other used (generated) frequencies in the EUT:**

Reference Clock : 13.824 MHz

## TEST CONDITIONS

**AC Powerline Conducted Emission Measurement (Sec.15.207(a))**  
was performed in the following test site.

### Test location:

KITA-KANSAI Testing Center

7-7, Ishimaru, 1-Chome, Mino-Shi, Osaka, 562-0027, Japan

● - Shielded room

KAMEOKA EMC Branch

9-1, Ozaki, Inukanno, Nishibetsuin-Cho, Kameoka-Shi, Kyoto, 621-0126, Japan

○ - Shielded room

○ - On metal plane of open site

### Used test instruments and sites:

Model No.	Device ID	Last Cal. Date	Cal. Interval
○ - ESCS 30	A - 1		
● - ESH 2	A - 2	May, 2001	1 Year
○ - ESH 2	A - 3		
● - KNW-407	D - 6	January, 2001	1 Year
○ - KNW-408	D - 11		
○ - KNW-242	D - 7		
○ - ESH3-Z5	D - 12		
○ - KNW-341C	D - 13		
○ - KNW-408	D - 14		
○ - KNW-244C	D - 77		
○ - KNW-408	D - 78		
○ - ESH2-Z5	D - 10		
○ - ESH2-Z3	D - 17		
○ - 65 BNC-50-0-1	H - 26		
○ - 65 BNC-50-0-1	H - 27		
○ - Cable	H - 7		
● - Cable	H - 8	January, 2001	1 Year

### Environmental conditions:

Temperature: 22 °C      Humidity: 44 %

**Magnetic Field Radiated Emission Measurement (Sec.15.247(c),15.205(a),15.209(a))**

was performed in the frequency range of 9 kHz - 30 MHz, in the following test site.

**Test location:**

KITA-KANSAI Testing Center

7-7, Ishimaru, 1-Chome, Mino-Shi, Osaka, 562-0027, Japan

● - 1st open test site (3 meters)

○ - 2nd open test site (3 meters)

KAMEOKA EMC Branch

9-1, Ozaki, Inukanno, Nishibetsuin-Cho, Kameoka-Shi, Kyoto, 621-0126, Japan

○ - 1st open test site                      ○ - 3 m                      ○ - 10 m                      ○ - 30 m

○ - 2nd open test site                      ○ - 3 m                      ○ - 10 m

**Used test instruments:**

Model No.	Device ID	Last Cal. Date	Cal. Interval
● - ESCS 30	A - 1	August, 2001	1 Year
○ - ESH 2	A - 2		
○ - ESH 2	A - 3		
● - HFH2-Z2	C - 2	July, 2001	1 Year
○ - HFH2-Z2	C - 3		

**Environmental conditions:**

Temperature: 21 °C      Humidity: 49 %

**Electromagnetic Field Radiated Emission Measurement (Sec.15.247(c),15.205(a),15.209(a))**

was performed in horizontal and vertical polarization, in the frequency range of 30 MHz - 1000 MHz, in the following test site.

**Test location:**

KITA-KANSAI Testing Center

7-7, Ishimaru, 1-Chome, Mino-Shi, Osaka, 562-0027, Japan

○ - 1st open test site (3 meters)

● - 2nd open test site (3 meters)

KAMEOKA EMC Branch

9-1, Ozaki, Inukanno, Nishibetsuin-Cho, Kameoka-Shi, Kyoto, 621-0126, Japan

○ - 1st open test site                      ○ - 3 m              ○ - 10 m              ○ - 30 m

○ - 2nd open test site                      ○ - 3 m              ○ - 10 m

**Validation of Site Attenuation:**

1) Last Confirmed Date : October 9, 2001

2) Interval : 1 Year

**Used test instruments:**

Model No.	Device ID	Last Cal. Date	Cal. Interval
○ - ESV/ESV-Z3	A - 7 / A - 17		
● - ESV/ESV-Z3	A - 6 / A - 18	December, 2000	1 Year
○ - ESV/ESV-Z3	A - 4 / A - 20		
○ - ESV/ESV-Z3	A - 8 / A - 19		
○ - ESVS 10	A - 5		
○ - KBA-511A	C - 12		
○ - KBA-611	C - 22		
● - KBA-511A	C - 13	November, 2001	1 Year
● - KBA-611	C - 19	November, 2001	1 Year
○ - KBA-511A	C - 11		
○ - KBA-611	C - 21		
○ - Cable	H - 1		
○ - Cable	H - 2		
○ - Cable	H - 5		
● - Cable	H - 6	November, 2001	1 Year
○ - Cable	H - 9		

**Environmental conditions:**

Temperature: 13 °C      Humidity: 54 %

**Electromagnetic Field Radiated Emission Measurement (Sec.15.247(c),15.205(a),15.209(a))  
Maximum Peak Power (EIRP) Measurement (Sec.15.247(b)(1))**

was performed in horizontal and vertical polarization, in the frequency range of 1 GHz - 25 GHz, in the following test site.

**Test location:**

KITA-KANSAI Testing Center

7-7, Ishimaru, 1-Chome, Mino-Shi, Osaka, 562-0027, Japan

● - 1st open test site (3 meters)

○ - 2nd open test site (3 meters)

KAMEOKA EMC Branch

9-1, Ozaki, Inukanno, Nishibetsuin-Cho, Kameoka-Shi, Kyoto, 621-0126, Japan

○ - 1st open test site                      ○ - 3 m                      ○ - 10 m                      ○ - 30 m

○ - 2nd open test site                      ○ - 3 m                      ○ - 10 m

**Used test instruments:**

Model No.	Device ID	Last Cal. Date	Cal. Interval
● - ESCS 30	A - 1	August, 2001	1 Year
● - 8566B	A - 13	December, 2000	1 Year
○ - 8593A	A - 15		
○ - ESV	A - 6		
● - 4T-10	D - 73	May, 2001	1 Year
○ - 4T-10	D - 74		
● - WJ-6611-513	A - 23	May, 2001	1 Year
● - WJ-6882-824	A - 21	May, 2001	1 Year
● - DBL-0618N515	A - 33	May, 2001	1 Year
● - 91888-2	C - 41 - 1	May, 2001	1 Year
● - 91889-2	C - 41 - 2	May, 2001	1 Year
○ - 94613-1	C - 41 - 3		
○ - 91891-2	C - 41 - 4		
○ - 94614-1	C - 41 - 5		
○ - 3160-04	C - 55		
● - 3160-05	C - 56	May, 2001	1 Year
● - 3160-06	C - 57	May, 2001	1 Year
● - 3160-07	C - 58	May, 2001	1 Year
● - 3160-08	C - 59	May, 2001	1 Year
● - 3160-09	C - 48	November, 2001	1 Year
● - 355C	D - 22	March, 2001	1 Year
● - 355D	D - 23	March, 2001	1 Year
● - MZ5010C	D - 81	November, 2001	1 Year
● - 8673D	B - 2	April, 2001	1 Year
● - Cable	C - 40 - 11	May, 2001	1 Year
● - Cable	C - 40 - 12	May, 2001	1 Year

**Environmental conditions:**

Temperature: 22 °C      Humidity: 48 %

**Transmitter Power (TP) Measurement (Sec.15.247(b)(1))**

**Test Procedure :**

The measurement test-setup is shown in the figure. The modulation is set to page 15.

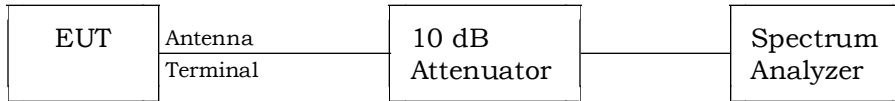

The setting of the spectrum analyzer are shown as follows :

Res. Bandwidth : 1 MHz  
Video Bandwidth : 3 MHz  
Span : 0 Hz  
Sweep Time : 20 msec  
Trace : Max. hold

**Test location :**

KITA-KANSAI Testing Center

7-7, Ishimaru, 1-Chome, Mino-Shi, Osaka, 562-0027, Japan

● - Shielded room

KAMEOKA EMC Branch

9-1, Ozaki, Inukanno, Nishibetsuin-Cho, Kameoka-Shi, Kyoto, 621-0126, Japan

○ - Shielded room

**Used test instruments and sites :**

Model No.	Device ID	Last Cal. Date	Cal. Interval
● - 8566B	A - 13	December, 2000	1 Year
○ - 432B/8478B	B - 24/B-43		
○ - 6-20	D - 27	September, 2001	1 Year
● - 2-10	D - 79		
○ - 4T-10	D - 73		
○ - 4T-10	D - 74		
○ - 8593A	A - 15		

**Environmental conditions :**

Temperature: 23 °C Humidity: 48 %

**-20dB Bandwidth Measurement (Sec.15.247(a)(1)(ii))**

**Test Procedure :**

The measurement test-setup is shown in the figure. The modulation is set to page 15.

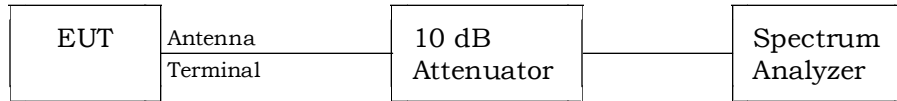

The setting of the spectrum analyzer are shown as follows :

Res. Bandwidth : 10 kHz  
Video Bandwidth : 30 kHz  
Span : 2 MHz  
Sweep Time : AUTO  
Trace : Max. hold

**Test location :**

KITA-KANSAI Testing Center

7-7, Ishimaru, 1-Chome, Mino-Shi, Osaka, 562-0027, Japan

● - Shielded room

KAMEOKA EMC Branch

9-1, Ozaki, Inukanno, Nishibetsuin-Cho, Kameoka-Shi, Kyoto, 621-0126, Japan

○ - Shielded room

**Used test instruments:**

Model No.	Device ID	Last Cal. Date	Cal. Interval
● - 8566B	A - 13	December, 2000	1 Year
● - 2-10	D - 79	September, 2001	1 Year
○ - 4T-10	D - 73		
○ - 4T-10	D - 74		

**Environmental conditions:**

Temperature: 23 °C Humidity: 48 %

**Band-edge Emission Measurement (Sec.15.247(c))**

**Test Procedure :**

The measurement test-setup is shown in the figure. The modulation is set to page 15.

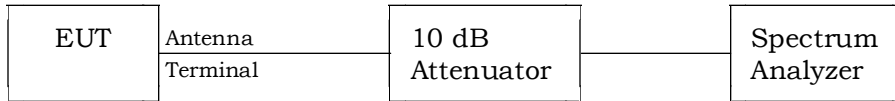

The setting of the spectrum analyzer are shown as follows :

Center Frequency : 2400 MHz / 2483.5 MHz  
Res. Bandwidth : 100 kHz  
Video Bandwidth : 300 kHz  
Span : 2 MHz  
Sweep Time : AUTO  
Trace : Max. hold

**Used test instruments:**

Model No.	Device ID	Last Cal. Date	Cal. Interval
● - 8566B	A - 13	December, 2000	1 Year
● - 2-10	D - 79	September, 2001	1 Year
○ - 4T-10	D - 73		
○ - 4T-10	D - 74		

**Environmental conditions:**

Temperature: 23 °C Humidity: 48 %

**Carrier Frequency Separation Measurement (Sec.15.247(a)(1))**

**Test Procedure :**

The measurement test-setup is shown in the figure. The modulation is set to page 15.  
The transmitting frequency is set to 2440.158968 MHz (45ch) and 2441.050839 MHz (46ch).

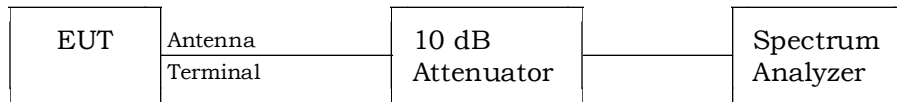

The setting of the spectrum analyzer are shown as follows :

Center Frequency : 2440.6 MHz  
Res. Bandwidth : 100 kHz  
Video Bandwidth : 300 kHz  
Span : 10 MHz  
Sweep Time : AUTO  
Trace : Max. hold

**Used test instruments:**

Model No.	Device ID	Last Cal. Date	Cal. Interval
● - 8566B	A - 13	December, 2000	1 Year
● - 2-10	D - 79	September, 2001	1 Year
○ - 4T-10	D - 73		
○ - 4T-10	D - 74		

**Environmental conditions:**

Temperature: 23 °C      Humidity: 48 %

**CONFIGURATION OF EUT**

**The Equipment Under Test (EUT) consists of:**

Description	Applicant (Manufacturer)	Model No. (Serial No.)	FCC ID
2.4GHz FHSS Cordless Telephone (Base Unit)	Kyushu Matsushita Electric Co., Ltd. (Kyushu Matsushita Electric Co., Ltd.)	KX-TG2730 (--)	ACJ96NKX-TG2730
AC Adapter	Kyushu Matsushita Electric Co., Ltd. (Kyushu Matsushita Electric Co., Ltd.)	PQLV10 (--)	N/A

**The measurement was carried out with the following equipment connected:**

Description	Grantee/Distributor	Model No. (Serial No.)	FCC ID
2.4GHz FHSS Cordless Telephone (Handset)	Kyushu Matsushita Electric Co., Ltd.	KX-TG2730 (--)	ACJ96NKX-TG2730

**Type of Interference Cable(s) and the AC Power Cord used with the EUT:**

	Description	Port	Shielded Cable	Shell Material	Ferrite Core	Cable Length
1	EUT	LINE	NO	--	NO	2.0 m
	----- No termination	--		--		
2	DC Power Cord (EUT / AC Adapter) 1φ 2-pin plug	--	NO	-- ----- --	NO	1.8 m

### **Operation - mode of the EUT:**

The EUT was operated during the test under the following specification:

- 1) Transmitting  
Modulation signal : TDMA/TDD Burst Type (FSK 164kHz dev.)
- 2) Charging the handset  
The handset is set on the base unit.

For operating condition of the EUT, the typical modulating signal is not used and inputted because the occupied bandwidth of the EUT is subject to restriction due to the bit rate of preamble data other than audio data in the transmitting data .

### **Test system:**

The EUT has a DC IN port and a LINE port.  
The EUT has diversity antenna system with 2 antennas. During the test, the transmitting power is connected to one of 2 antennas.

### **Special accessories:**

None

**EUT Modification**

- - No modifications were conducted by JQA to achieve compliance to applied levels.
- - To achieve compliance to applied levels, the following change(s) were made by JQA during the compliance test.

The modification(s) will be implemented in all production models of this equipment.

Applicant :  N/A  Date :  N/A   
Typed Name :  N/A  Position :  N/A

**Responsible Party**

Responsible Party of Test Item(Product)

Responsible party :

Contact Person :

\_\_\_\_\_  
Signatory

**Deviation from Standard**

- - No deviations from the standard described in page 3.
- - The following deviations were employed from the standard described in page 3.

\_\_\_\_\_  
\_\_\_\_\_

**TEST RESULTS**

**AC Powerline Conducted Emission 450 kHz - 30 MHz (Sec.15.207(a))**

The requirements are	<b>● - Passed</b>	<b>○ - Not Passed</b>
Min. limit margin	<u>22.1</u> dB	at <u>29.94</u> MHz
Max. limit exceeding	_____ dB	at _____ MHz
Uncertainty of measurement results	<u>+ 2.1</u> dB(2σ)	<u>- 2.1</u> dB(2σ)

Remarks: \_\_\_\_\_  
\_\_\_\_\_

**Electromagnetic Field Radiated Emission 9 kHz - 25 GHz**

**Maximum Peak Power (EIRP) (Sec.15.247(b)(1))**

The requirements are	<b>● - Passed</b>	<b>○ - Not Passed</b>
Maximum Peak Power (EIRP)	<u>0.066</u> W	at <u>2400.916645</u> MHz
Min. limit margin	<u>11.8</u> dB	at <u>2400.916645</u> MHz
Max. limit exceeding	_____ dB	at _____ MHz

**Spurious (Sec.15.247(c),15.205(a),15.209(a))**

The requirements are	<b>● - Passed</b>	<b>○ - Not Passed</b>
Min. limit margin	<u>2.3</u> dB	at <u>180.2</u> MHz
Max. limit exceeding	_____ dB	at _____ MHz
Uncertainty of measurement results (≤ 30 MHz)	<u>+ 2.5</u> dB(2σ)	<u>- 2.5</u> dB(2σ)
Uncertainty of measurement results (30 MHz - 1000 MHz)	<u>+ 4.9</u> dB(2σ)	<u>- 5.0</u> dB(2σ)
Uncertainty of measurement results (≥ 1000 MHz)	<u>+ 3.1</u> dB(2σ)	<u>- 3.2</u> dB(2σ)

Remarks: \_\_\_\_\_  
\_\_\_\_\_

**Transmitter Power (TP) (Sec.15.247(b)(1))**

The requirements are	● - Passed	○ - Not Passed
The transmitter power is	<u>0.066</u> W	at <u>2400.916645</u> MHz
Min. limit margin	<u>11.8</u> dB	at <u>2400.916645</u> MHz
Max. limit exceeding	_____ dB	at _____ MHz
Uncertainty of measurement results		<u>± 0.6</u> dB(2σ)

Remarks: \_\_\_\_\_  
\_\_\_\_\_

**Antenna Gain of the EUT (Sec.15.247(b)(3)(i))**

The antenna gain is 0.90 dBi at 2440.158968 MHz

Remarks: \_\_\_\_\_  
\_\_\_\_\_

**-20dB Bandwidth (Sec.15.247(a)(1)(ii))**

The requirements are	● - Passed	○ - Not Passed
The -20dB Bandwidth is	<u>630.0</u> kHz	at <u>2400.916645</u> MHz
The results	Refer to pages	<u>37 - 39</u>
Min. limit margin	<u>370.0</u> kHz	at <u>2400.916645</u> MHz
Max. limit exceeding	_____ kHz	at _____ MHz
Uncertainty of measurement results at Frequency		<u>±0.05</u> ppm(2σ)
Uncertainty of measurement results at Amplitude		<u>± 0.6</u> dB(2σ)

Remarks: \_\_\_\_\_  
\_\_\_\_\_

**Band-edge Emission (Sec.15.247(c))**

The requirements are

● - Passed      ○ - Not Passed

The results

Refer to pages 40 - 41

Uncertainty of measurement results at Frequency

±0.05 ppm(2σ)

Uncertainty of measurement results at Amplitude

± 0.6 dB(2σ)

Remarks: \_\_\_\_\_  
\_\_\_\_\_

**Carrier Frequency Separation (Sec.15.247(a)(1))**

The requirements are

● - Passed      ○ - Not Passed

Channel Separation

890 kHz

The results

Refer to page 43

Uncertainty of measurement results at Frequency

±0.05 ppm(2σ)

Uncertainty of measurement results at Amplitude

± 0.6 dB(2σ)

Remarks: \_\_\_\_\_  
\_\_\_\_\_

**SUMMARY**

**GENERAL REMARKS :**

The EUT was tested according to the requirements of FCC Rules and Regulations Part 15 Subpart A and C (February 28, 2001) under the test configuration, as shown in page 21.

The conclusion for the test items of which are required by the applied regulation is indicated under the final judgement.

**FINAL JUDGEMENT :**

The "as received" sample;

- - fulfill the test requirements of the regulation mentioned on page 3.
- - fulfill the test requirements of the regulation mentioned on page 3, but with certain qualifications.
- - doesn't fulfill the test regulation mentioned on page 3.

Begin of testing : December 4, 2001

End of testing : December 5, 2001

- JAPAN QUALITY ASSURANCE ORGANIZATION -

Approved by :

Issued by :



Akio Hosoda  
Manager  
EMC Div.  
JQA KITA-KANSAI Testing Center

Shigeru Kinoshita  
Deputy Manager  
EMC Div.  
JQA KITA-KANSAI Testing Center

**Test System-Arrangement (Drawings)**

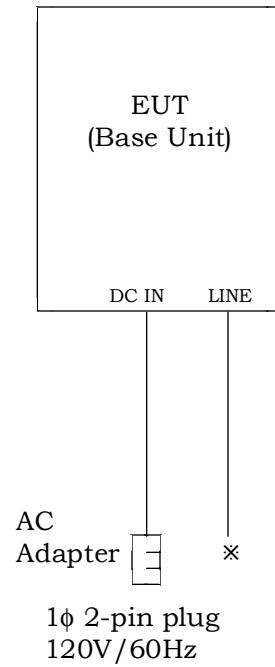

Note)  
× : No termination

### Preliminary Test and Test-setup(Drawings)

#### AC Powerline Conducted Emission 450 kHz - 30 MHz:

The preliminary test was performed according to the description of ANSI C63.4-1992 Sec.7.2.3 (Preliminary AC Powerline Conducted Emissions Tests) and Sec.6.2.1 (Tabletop Equipment Tests). The preliminary test was carried out to investigate the frequency of the emission that has the highest amplitude relative to the limits within normal operating modes, cable positions, and a typical system configuration. In order to find out to the maximum emission, the preliminary test and a final test were performed in accordance with the following steps.

Step 1: One operation mode of the test system was setting.

Step 2: Using both of a spectrum analyzer and a test receiver, the emission's circumstance from the system was monitored in one of ten divided frequency bands of the specified frequency range (450 kHz - 30 MHz). The maximum emission in the band was found by changing the typical cable positions or cable manipulation under a typical system configuration and by selecting of current-carrying conductor. The level and the frequency at the one point which are regarded as relative high emission in the band was measured and recorded. This step was repeated until the ending frequency band.

Step 3: Return to step 1, if the other operation mode was possible to be setting.

Step 4: Based on the collected results, the operation mode produced the maximum emission was selected. The final test on the selected operation mode was performed. But if it was difficult to select the operation mode, the final tests on all operation modes were performed.

Step 5: Based on the same data, as result if the final measurement, at the worst point that has the highest amplitude relative to the limit the repeatability of the worst was reconfirmed.

The photographs of the test system setup on the worst point were taken and recorded.

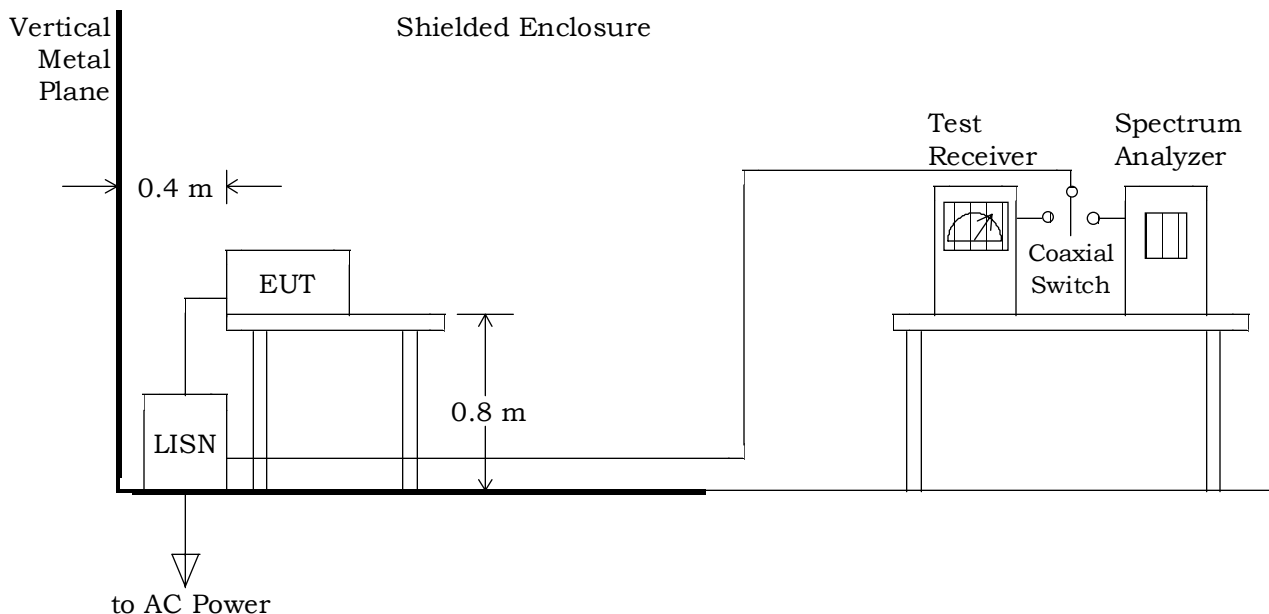

Radiated Emission (Magnetic Field) 9 kHz - 30 MHz:

The preliminary test was performed according to the description of ANSI C63.4-1992 Sec.8.3.1.1 (Preliminary Radiated Emissions Tests) and Sec.6.2.1 (Tabletop Equipment Tests).

The preliminary test was carried out to investigate the frequency of the emission that has the highest amplitude relative to the limits within normal operating modes, cable positions, and a typical system configuration. In order to find out to the maximum emission, the preliminary test and a final test were performed in accordance with the following steps.

Step 1: One operation mode of the test system was setting.

Step 2: In order to investigate the frequencies of maximum emissions, the loop antenna position was approached to the EUT and the significant frequency of the emission's circumstance from the test system were investigated. These data were recorded in the specified frequency band (9 kHz - 30 MHz).

Step 3: Using a test receiver and a loop antenna, the emission's circumstance from the test system was measured in according with ANSI C63.4-1992 Sec.8.3.1.2 (Final Radiated Emissions Tests) at each frequency which was found the higher emission referred to level vs. frequency on the list and which was measured by the loop antenna. The maximum emission was found by changing the antenna angle under a typical system configuration.

Step 4: Return to step 1, if the other operation mode was possible to be setting.

Step 5: The worst result was reported arranging data of which was obtained and performed by one or plural operation modes as the final test.

At the worst point that has the highest amplitude relative to the limit the repeatability of the level was reconfirmed. The photographs of the tests system setup on the worst point were taken and recorded.

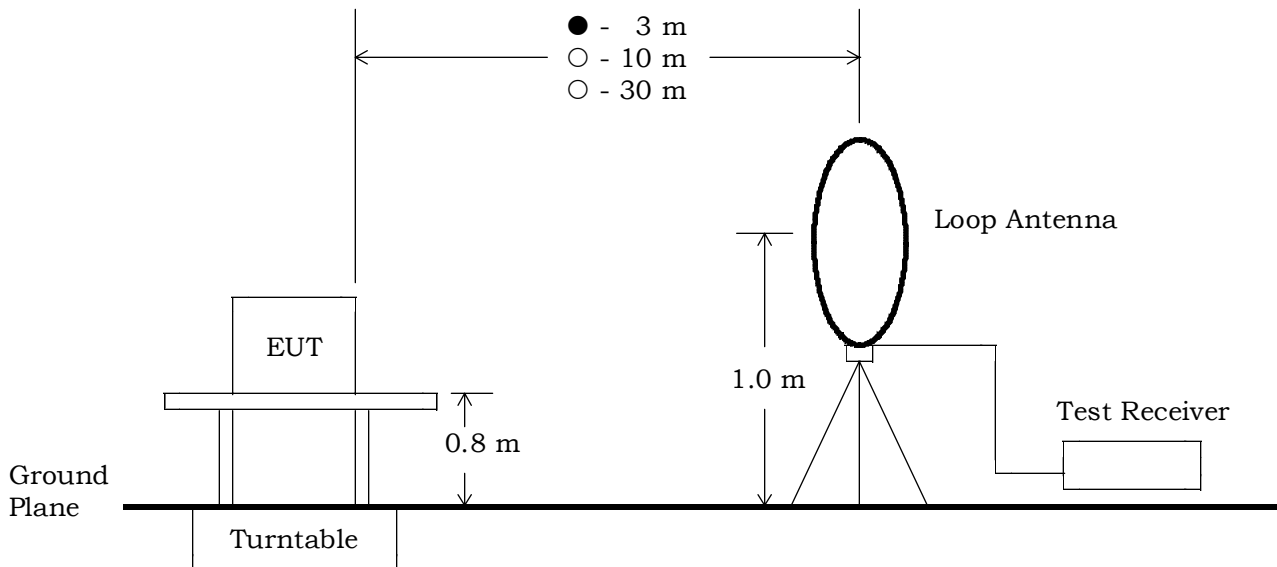

Electromagnetic Field Radiated Emission 30 MHz - 1000 MHz:

The preliminary test was performed according to the description of ANSI C63.4-1992 Sec.8.3.1.1 (Preliminary Radiated Emissions Tests) and Sec.6.2.1 (Tabletop Equipment Tests).

The preliminary test was carried out to investigate the frequency of the emission that has the highest amplitude relative to the limits within normal operating modes, cable positions, and a typical system configuration. In order to find out to the maximum emission, the preliminary test and a final test were performed in accordance with the following steps.

Step 1: One operation mode of the test system was setting.

Step 2: Using a test receiver and a test antenna probe, the significant frequency of the emission's circumstance from the test system were investigated. These data were recorded every one of 22 divided bands in the specified frequency band (30 MHz - 1000 MHz).

Step 3: Using a test receiver and a resonant tuned dipole antenna, the emission's circumstance from the test system was measured in according with ANSI C63.4-1992 Sec.8.3.1.2 (Final Radiated Emissions Tests) at each frequency which was found the higher emission referred to level vs. frequency on the list and which was measured by the resonant tuned dipole antenna. The maximum emission was found by changing the antenna angle under a typical system configuration.

Step 4: Return to step 1, if the other operation mode was possible to be setting.

Step 5: The worst result was reported arranging data of which was obtained and performed by one or plural operation modes as the final test.

At the worst point that has the highest amplitude relative to the limit the repeatability of the level was reconfirmed. The photographs of the tests system setup on the the worst point were taken and recorded.

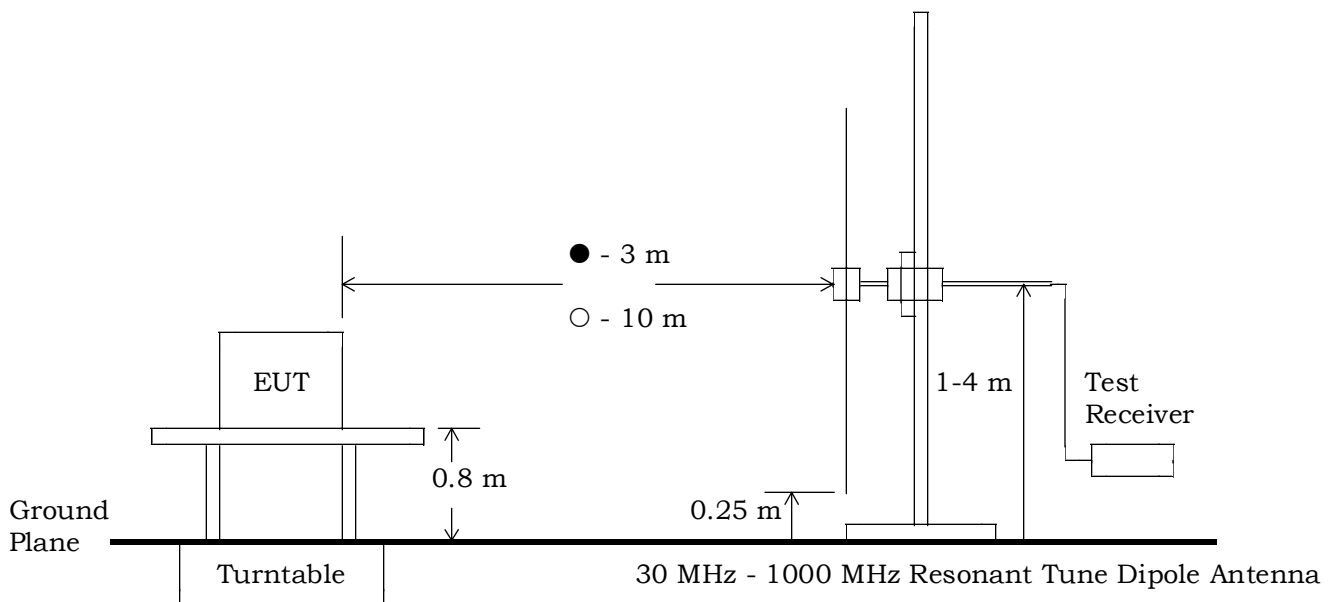

Electromagnetic Field Radiated Emission 1 GHz - 25 GHz:

The preliminary test was performed according to the description of ANSI C63.4-1992 Sec.8.3.1.1 (Preliminary Radiated Emissions Tests) and Sec.6.2.1 (Tabletop Equipment Tests).

The preliminary test was carried out to investigate the frequency of the emission that has the highest amplitude relative to the limits within normal operating modes, cable positions, and a typical system configuration. In order to find out to the maximum emission, the preliminary test and a final test were performed in accordance with the following steps.

Step 1: One operation mode of the test system was setting.

Step 2: In order to investigate the frequencies of maximum emissions, the horn antenna position was approached to the EUT and the significant frequency of the emission's circumstance from the test system were investigated. These data were recorded in the specified frequency band (1 GHz - 25 GHz).

Step 3: The emission's circumstance from the test system was measured in accordance with ANSI C63.4-1992, Sec.8.3.1.2 (Final Radiated Emissions Tests) at each frequency which was found higher emission referred to level vs. frequency on the list and which was measured in the specified distance using the horn antenna. The maximum emission was found by changing the antenna angle under a typical system configuration.

Step 4: Return to step 1, if the other operation mode was possible to be setting.

Step 5: The worst result was reported arranging data of which was obtained and performed by one or plural operation modes as the final test.

At the worst point that has the highest amplitude relative to the limit the repeatability of the level was reconfirmed. The photographs of the tests system setup on the the worst point were taken and recorded.

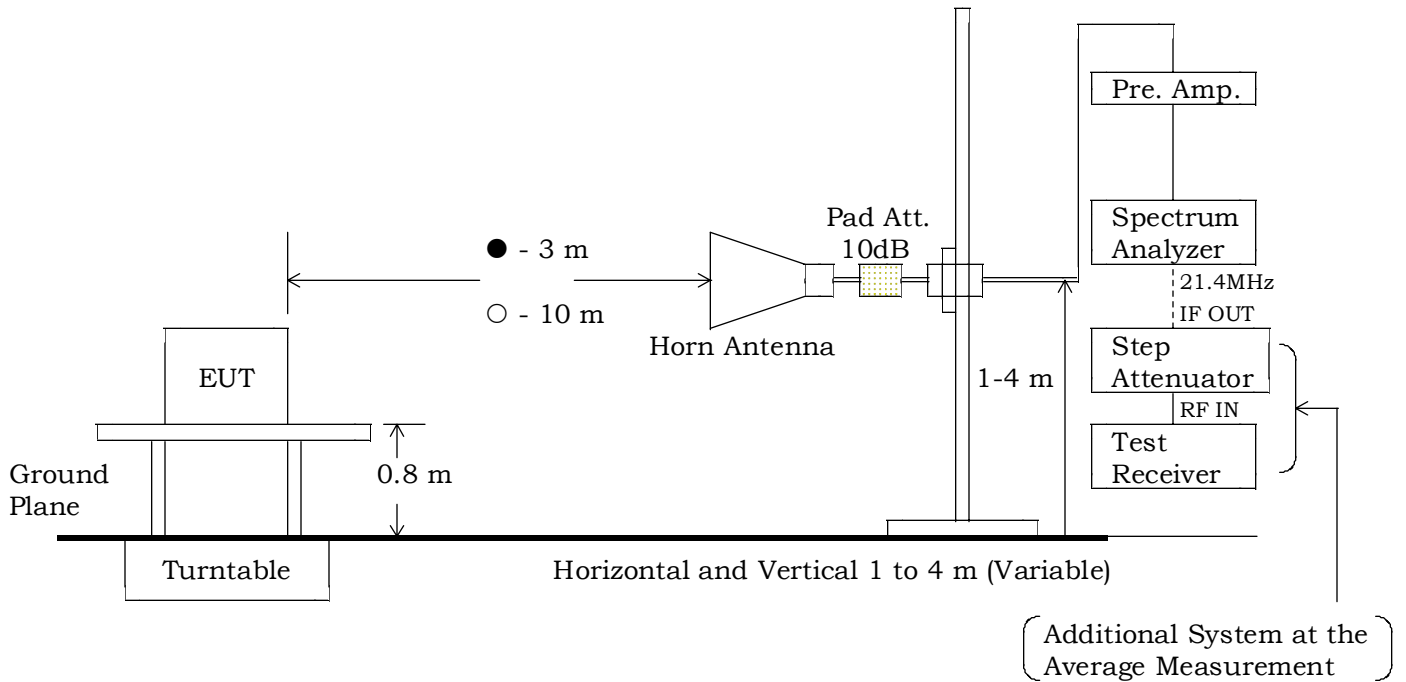

Spectrum Analyzer Setting:

Detector	*)Peak/Average
RES BW	1 MHz
VIDEO BW	1 MHz
SPAN	0 Hz

Test Receiver Setting:

SCALE	LINEAR	LINEAR
I.F.B.W.	1 MHz	1 MHz
Detector	Average	Peak

\*) For the average measurement, it is made using a test receiver and a step attenuator.

**Test-Setup (Photographs) at worst case**

Conducted Emission 450kHz - 30MHz:



Front View

Radiated Emission 9kHz - 25GHz:



Front View

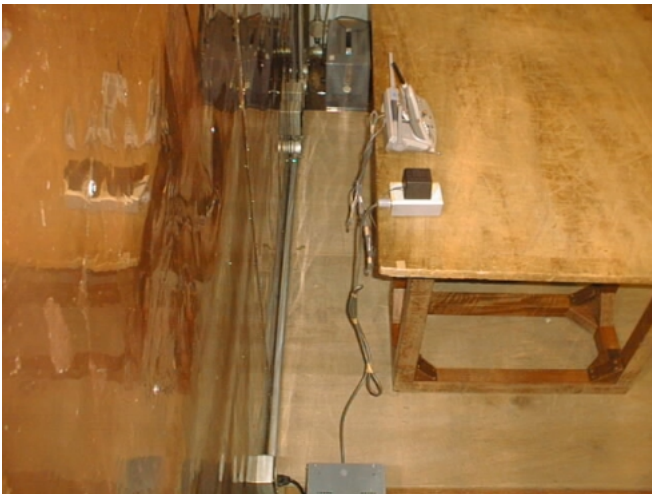

Side View



Rear View

**AC Powerline Conducted Emission Measurement**  
 Intentional Radiator

Mode of Operation : Charging

Test Date: December 5, 2001  
 Temp.: 22 °C ; Humi.: 44 %

Frequency [MHz]	Correction Factor [dB]	Meter Readings [dB(μV)]				Limits [dB(μV)]	Results [dB(μV)]		Margin [dB]	Remarks (Note 2)
		VA		VB			QP	AV		
		QP	AV	QP	AV		QP	AV		
0.45	0.1	12.0	-	12.0	-	48.0	12.1	-	+35.9	A
1.00	0.1	<10.0	-	<10.0	-	48.0	<10.1	-	>+37.9	A
3.50	0.3	<10.0	-	<10.0	-	48.0	<10.3	-	>+37.7	A
6.00	0.4	<10.0	-	<10.0	-	48.0	<10.4	-	>+37.6	A
13.82	0.6	13.0	-	16.0	-	48.0	16.6	-	+31.4	A
16.09	0.7	18.0	-	19.0	-	48.0	19.7	-	+28.3	A
29.94	0.9	22.0	-	25.0	-	48.0	25.9	-	+22.1	A

Sample of calculated result at 29.94 MHz, as the Minimum Margin point:

Correction Factor = 0.9 dB  
 +) Meter Reading = 25.0 dB(μV)  
 Result = 25.9 dB(μV)

Minimum Margin : 48.0 - 25.9 = 22.1(dB)

The point shown on “    ” is the Minimum Margin Point.

Note 1:

1)The correction factor includes the LISN insertion loss and the cable loss.

Remarks:

Note 2	Detector Function	IF Bandwidth
A	CISPR QP	9 kHz
B	Average	10 kHz

Tester : Yasuhisa Sakai

## Electromagnetic Field Radiated Emission Measurement

Intentional Radiator

Spurious emission except fundamental and harmonics (9 kHz - 1 GHz)

Test Date: December 5, 2001

Temp.: 13 °C ; Humi.: 54 %

**Transmitting Frequency : 2440.158968 MHz (45 ch)**

Frequency [MHz]	Antenna Factor [dB(1/m)]	Cable Loss [dB]	Meter Readings [dB(μV)]		Limits [dB(μV/m)]	Results [dB(μV/m)]		Margin [dB]	Remarks (Note 2)
			Hori.	Vert.		Hori.	Vert.		
180.2	14.0	1.2	23.0	26.0	43.5	38.2	41.2	+ 2.3	C
207.4	15.2	1.3	< 15.0	17.0	43.5	< 31.5	33.5	+10.0	C
276.5	17.7	1.5	17.0	11.0	46.0	36.2	30.2	+ 9.8	C
304.1	18.5	1.6	19.0	6.0	46.0	39.1	26.1	+ 6.9	C
360.4	20.1	1.7	16.0	12.0	46.0	37.8	33.8	+ 8.2	C
450.6	22.3	2.0	19.0	16.0	46.0	43.3	40.3	+ 2.7	C
540.7	24.0	2.4	14.0	9.0	46.0	40.4	35.4	+ 5.6	C
630.8	25.5	2.5	4.0	8.0	46.0	32.0	36.0	+10.0	C
788.0	27.6	2.9	5.0	2.0	46.0	35.5	32.5	+10.5	C
912.4	29.0	3.0	5.0	4.0	46.0	37.0	36.0	+ 9.0	C

Sample of calculated result at 180.2 MHz, as the Minimum Margin point:

Antenna Factor	=	14.0 dB(1/m)
+) Cable Loss	=	1.2 dB
Meter Reading	=	26.0 dB(μV)
Result	=	41.2 dB(μV/m)

Minimum Margin : 43.5 - 41.2 = 2.3(dB)

The point shown on “    ” is the Minimum Margin Point.

Note 1:

- 1)The highest frequency generated or used in the EUT: 2480.293161 MHz
- 2)The upper frequency of measurement range : 25 GHz
- 3)The spectrum was scanned 9 kHz to 1 GHz and all emissions not reported were more than 20 dB below the applied limits.

**Remarks:**

Note 2	Detector Function	IF Bandwidth
A	CISPR QP	200 Hz
B	CISPR QP	9 kHz
C	CISPR QP	120 kHz
D	Average	200 Hz
E	Average	10 kHz
F	Average	120 kHz

Tester : Yasuhisa Sakai

**Electromagnetic Field Radiated Emission Measurement**  
 Intentional Radiator  
 Fundamental and Spurious (above 1 GHz)

Test Date: December 4, 2001  
 Temp.: 22 °C ; Humi.: 48 %

**Transmitting Frequency : 2400.916645 MHz (01ch)**

Frequency [MHz]	Antenna Factor [dB(1/m)]	Corr. Factor [dB]	Meter Readings at 3m [dB(μV)]		Limits [dB(μV/m)]	Results at 3m [dB(μV/m)]		Margin [dB]	Remarks (Note 2)
			Hori.	Vert.		Hori.	Vert.		
<b>Fundamental</b>									
2400.916645	21.6	10.8	80.0	81.0	---	112.4	113.4	---	B
<b>Spurious at Peak Detector</b>									
* 4801.833290	27.3	-31.2	52.0	56.0	74.0	48.1	52.1	+21.9	D
7202.749935	29.9	-29.5	49.0	48.0	93.4	49.4	48.4	+44.0	B
9603.666580	33.4	-27.5	43.0	42.0	93.4	48.9	47.9	+44.5	B
* 12004.583225	33.6	-26.7	< 40.0	< 40.0	74.0	< 46.9	< 46.9	> +27.1	D
14405.499870	37.1	-26.3	< 40.0	< 40.0	93.4	< 50.8	< 50.8	> +42.6	B
16806.416515	37.2	-27.0	< 40.0	< 40.0	93.4	< 50.2	< 50.2	> +43.2	D
* 19207.333160	40.2	-28.0	< 40.0	< 40.0	74.0	< 52.2	< 52.2	> +21.8	B
21608.249805	40.3	-28.2	< 40.0	< 40.0	93.4	< 52.1	< 52.1	> +41.3	B
24009.166450	40.4	-28.2	< 40.0	< 40.0	93.4	< 52.2	< 52.2	> +41.2	B
<b>Spurious at Average Detector</b>									
* 4801.833290	27.3	-31.2	34.0	38.0	54.0	30.1	34.1	+19.9	C
* 12004.583225	33.6	-26.7	< 30.0	< 30.0	54.0	< 36.9	< 36.9	> +17.1	C
* 19207.333160	40.2	-28.0	< 30.0	< 30.0	54.0	< 42.2	< 42.2	> +11.8	C

**Transmitting Frequency : 2440.158968 MHz (45ch)**

Frequency [MHz]	Antenna Factor [dB(1/m)]	Corr. Factor [dB]	Meter Readings at 3m [dB(μV)]		Limits [dB(μV/m)]	Results at 3m [dB(μV/m)]		Margin [dB]	Remarks (Note 2)
			Hori.	Vert.		Hori.	Vert.		
<b>Fundamental</b>									
2440.158968	21.5	10.8	79.0	81.0	---	111.3	113.3	---	B
<b>Spurious at Peak Detector</b>									
* 4880.317936	27.3	-31.2	52.0	53.0	74.0	48.1	49.1	+24.9	D
* 7320.476904	29.9	-29.4	51.0	51.0	74.0	51.5	51.5	+22.5	D
9760.635872	33.5	-27.4	< 40.0	< 40.0	93.3	< 46.1	< 46.1	> +47.2	B
* 12200.794840	33.6	-26.6	< 40.0	< 40.0	74.0	< 47.0	< 47.0	> +27.0	D
14640.953808	37.1	-26.4	< 40.0	< 40.0	93.3	< 50.7	< 50.7	> +42.6	B
17081.112776	37.2	-27.1	< 40.0	< 40.0	93.3	< 50.1	< 50.1	> +43.2	B
* 19521.271744	40.3	-27.8	< 40.0	< 40.0	74.0	< 52.5	< 52.5	> +21.5	D
21961.430712	40.3	-27.9	< 40.0	< 40.0	93.3	< 52.4	< 52.4	> +40.9	B
24401.589680	40.4	-28.7	< 40.0	< 40.0	93.3	< 51.7	< 51.7	> +41.6	B
<b>Spurious at Average Detector</b>									
* 4880.317936	27.3	-31.2	34.0	35.0	54.0	30.1	31.1	+22.9	C
* 7320.476904	29.9	-29.4	33.0	33.0	54.0	33.5	33.5	+20.5	C
* 12200.794840	33.6	-26.6	< 30.0	< 30.0	54.0	< 37.0	< 37.0	> +17.0	C
* 19521.271744	40.3	-27.8	< 30.0	< 30.0	54.0	< 42.5	< 42.5	> +11.5	C

**Transmitting Frequency : 2480.913161 MHz (90ch)**

Frequency [MHz]	Antenna Factor [dB(1/m)]	Corr. Factor [dB]	Meter Readings at 3m [dB(μV)]		Limits [dB(μV/m)]	Results at 3m [dB(μV/m)]		Margin [dB]	Remarks (Note 2)
			Hori.	Vert.		Hori.	Vert.		
<b>Fundamental</b>									
2480.913161	21.4	10.8	77.0	80.0	---	109.2	112.2	---	B
<b>Spurious at Peak Detector</b>									
* 4961.826322	27.3	-31.2	51.0	50.0	74.0	47.1	46.1	+26.9	D
* 7442.739483	30.0	-29.4	49.0	48.0	74.0	49.6	48.6	+24.4	D
9923.652644	33.5	-27.4	< 40.0	< 40.0	92.2	< 46.1	< 46.1	> +46.1	B
* 12404.565805	37.0	-26.6	< 40.0	< 40.0	74.0	< 50.4	< 50.4	> +23.6	D
14885.478966	37.1	-26.4	< 40.0	< 40.0	92.2	< 50.7	< 50.7	> +41.5	B
17366.392127	37.2	-27.1	< 40.0	< 40.0	92.2	< 50.1	< 50.1	> +42.1	B
* 19847.305288	40.3	-27.4	< 40.0	< 40.0	74.0	< 52.9	< 52.9	> +21.1	D
* 22328.218449	40.4	-27.6	< 40.0	< 40.0	92.2	< 52.8	< 52.8	> +39.4	D
24809.131610	40.4	-28.8	< 40.0	< 40.0	92.2	< 51.6	< 51.6	> +40.6	B
<b>Spurious at Average Detector</b>									
* 4961.826322	27.3	-31.2	33.0	32.0	54.0	29.1	28.1	+24.9	C
* 7442.739483	30.0	-29.4	30.0	< 30.0	54.0	30.6	< 30.6	+23.4	C
* 12404.565805	37.0	-26.6	< 30.0	< 30.0	54.0	< 40.4	< 40.4	> +13.6	C
* 19847.305288	40.3	-27.4	< 30.0	< 30.0	54.0	< 42.9	< 42.9	> +11.1	C
* 22328.218449	40.4	-27.6	< 30.0	< 30.0	54.0	< 42.8	< 42.8	> +11.2	C

Sample of calculated result at 19847.305288 MHz, as the Minimum Margin point:

Antenna Factor = 40.3 dB(1/m)  
 Corr. Factor = -27.4 dB  
 +) Meter Reading = <30.0 dB(μV)  
 Result = <42.9 dB(μV/m)

Minimum Margin : 54.0 - <42.9 = >11.1(dB)

The point shown on “\_\_\_\_\_” is the Minimum Margin Point.

Note 1:

- 1)The highest frequency generated or used in the EUT: 2480.293161 MHz
- 2)The upper frequency of measurement range : 25 GHz
- 3)The spectrum was scanned 1 GHz to 25 GHz and all emissions not reported were more than 20 dB below the applied limits.
- 4)Symbol '\*' : Restricted bands of operation in Sec.15.205.
- 5)Corr. Factor (Fundamental) = Cable Loss + 10 dB Pad Attenuator [dB]  
 Corr. Factor (≤ 18 GHz except Fundamental) = Cable Loss + 10 dB Pad Attenuator - Amp. Gain [dB]  
 Corr. Factor (≥ 18 GHz) = Cable Loss - Amp. Gain + Mixer Conversion Loss(at IF=8GHz)[dB]

**Remarks:**

Note 2	Detector Function	RES. B.W.	V.B.W.	Sweep T	Span
A	Peak (SP)	1 MHz	1 MHz	20 msec	0 Hz
B	Peak (SP)	100 kHz	300 kHz	20 msec	0 Hz
*) C	Average (Receiver)	1 MHz (1 MHz)	3 MHz	20 msec	0 Hz
D	Peak	1 MHz	3 MHz	20 msec	0 Hz

( ):Setting of spectrum analyzer

\*)For the average/peak measurement method, it is made measurement using a test receiver, a step attenuator or and a spectrum analyzer(FCC REPLY No. 950523A).

Tester : Yasuhisa Sakai

## Maximum Peak Power (EIRP) Measurement Fundamental Emission

Test Date: December 4, 2001  
 Temp.: 22 °C ; Humi.: 48 %

Measurement Results:

**Radiated Emission Measurement at 3m**

Frequency [MHz]	Antenna Factor [dB(1/m)]	Corr. Factor [dB]	Meter Readings at 3m [dB(μV)]		Results at 3m [dB(μV/m)]		Remarks (Note 1)
			Hori.	Vert.	Hori.	Vert.	
<b>Fundamental</b>							
2400.916645	21.6	10.8	80.0	81.0	112.4	113.4	A
2440.158968	21.5	10.8	79.0	81.0	111.3	113.3	A
2480.293161	21.4	10.8	77.0	80.0	109.2	112.2	A

**Remarks:**

Note 1	Detector Function	RES. B.W.	V.B.W.	Sweep T	Span
A	Peak	1 MHz	3 MHz	20 msec	0 Hz

Calculated Results:

CH No.	Frequency (MHz)	Maximum Peak Power EIRP(W)		Limits (W)	Margin (dB)
		Hori.	Vert.		
01	2400.916645	0.052	0.066	1.000	+11.8
45	2440.158968	0.040	0.064	1.000	+11.9
90	2480.293161	0.025	0.050	1.000	+13.0

The EUT is placed at 3 m away from the receiving antenna and the EIRP is calculated using the following formula:

$$E^2 / (120\pi) = \text{EIRP} / (4\pi d^2) \quad \text{where} \quad \text{EIRP} = P_h \cdot G_h, \quad E : \text{Field Strength at } d \text{ (distance) m } [\mu\text{V/m}]$$

$$\text{EIRP} = (d \cdot E)^2 / 30 \quad G_h = \text{Substituted Antenna [dBi]}$$

$$\text{EIRP [W]} = (3 \times E [\mu\text{V/m}] \times 10^{-6})^2 / 30 \quad P_h = \text{Input power at the Substituted Antenna [W]}$$

The point shown on “\_\_\_\_\_” is the Minimum Margin Point.

Minimum Margin Point, as 2400.916645 MHz :  $10\log(1.000 / 0.066) = 11.8 \text{ (dB)}$

Tester : Yasuhisa Sakai

### Transmitter Power(TP) Measurement

Test Date: December 4, 2001  
 Temp.: 23 °C ; Humi.: 48 %

Measurement Results:

CH No.	Frequency (MHz)	Corr. Factor (dB)	Meter Reading (dBm)	Result (dBm)	Result (W)	Limits (W)	Margin (dB)	Remarks (Note 1)
01	2400.916645	10.8	7.4	18.2	0.066	1.000	+11.8	A
45	2440.158968	10.8	6.4	17.2	0.052	1.000	+12.8	A
90	2480.293161	10.8	5.7	16.5	0.045	1.000	+13.5	A

Sample of calculated result at 2400.916645 MHz, as the Minimum Margin point:

Correction Factor = 10.8 dB  
 +) Meter Reading = 7.4 dBm  
 Result = 18.2 dBm :  $10^{(18.2/10)} \times 10^{-3} = 0.066$  (W)

Minimum Margin : 30.0 - 18.2 = 11.8(dB)

The point shown on “    ” is the Minimum Margin Point.

Note : 1. The correction factor includes the attenuator loss and the cable loss.

**Remarks:**

Note 2	Detector Function	RES. B.W.	V.B.W.	Sweep T	Span
A	Peak	1 MHz	3 MHz	20 msec	0 Hz

Tester : Yasuhisa Sakai

### Calculated Antenna gain of the EUT

Calculated Results:

Antenna gain of the integrated antenna of the EUT :  $G_{EUT}$  (dB)  
 Transmitter power (Measured) : TP (dBm)  
 EIRP (Measured) : EIRP (dBm)

If the antenna gain ( $G_{EUT}$ ) is met the equations as follows.

$$EIRP = TP \times G_{EUT}$$

$$G_{EUT} \text{ (Numeric)} = EIRP / TP$$

$$G_{EUT} \text{ (dB)} = 10\log_{10}(EIRP / TP)$$

CH No.	Frequency (MHz)	EIRP (W)	TP (W)	$G_{EUT}$ (dBi)
01	2400.916645	0.066	0.066	0.00
45	2440.158968	0.064	0.052	0.90
90	2480.293161	0.050	0.045	0.46

Sample of calculated result at 2440.158968 MHz, as the Maximum point:

EIRP	=	18.06 dBm = $10\log_{10}(0.064) + 30$
-) TP	=	17.16 dBm = $10\log_{10}(0.052) + 30$
Result	=	0.90 dBi

The point shown on “ \_\_\_\_ ” is the Maximum Point.

**-20dB bandwidth and Band-edge Emission Measurement**  
Fundamental Emission

Test Date: December 4, 2001  
Temp.: 23 °C ; Humi.: 48 %

1) -20dB bandwidth measurement

Measurement Results:

<b>CH No.</b>	<b>Frequency (MHz)</b>	<b>-20dB bandwidth (kHz)</b>	<b>Attached graph page</b>
00	2400.916645	630	page 37
46	2440.158968	616	page 38
91	2480.293161	626	page 39

The point shown on “\_\_\_\_\_” is the Minimum Margin Point.

2) Band-edge Emission measurement

Measurement Results:

<b>CH No.</b>	<b>Frequency (MHz)</b>	<b>Band-edge Frequency (MHz)</b>	<b>Attached graph page</b>
00	2400.916645	2400.000	page 40
91	2480.293161	2483.500	page 41

Tester : Yasuhisa Sakai

**-20dB Bandwidth Measurement**

Transmitting Frequency : 2400.916645 MHz (01 ch)

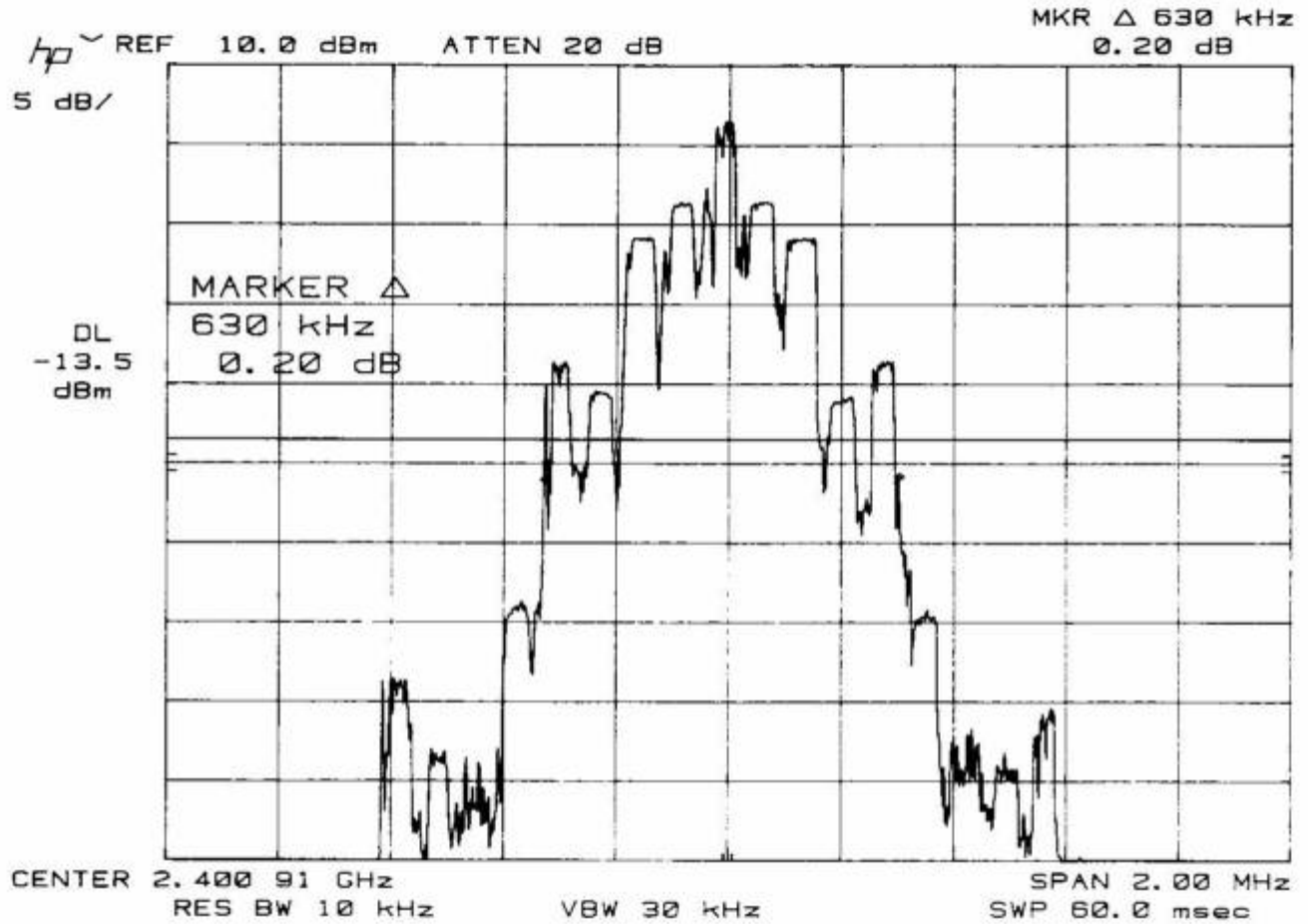

**-20dB Bandwidth Measurement**

Transmitting Frequency : 2440.158968 MHz (45 ch)

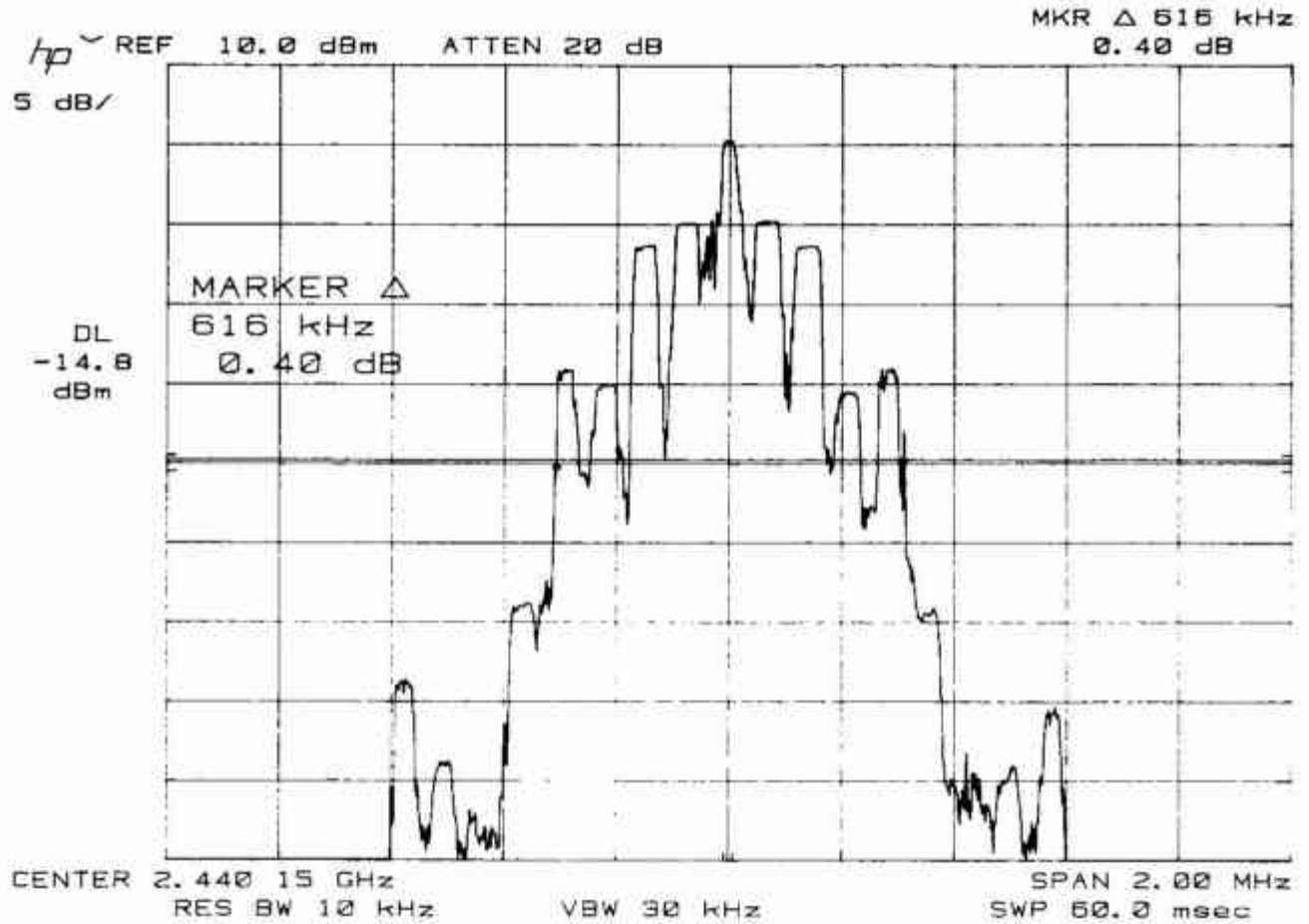

**-20dB Bandwidth Measurement**

Transmitting Frequency : 2480.293161 MHz (90 ch)

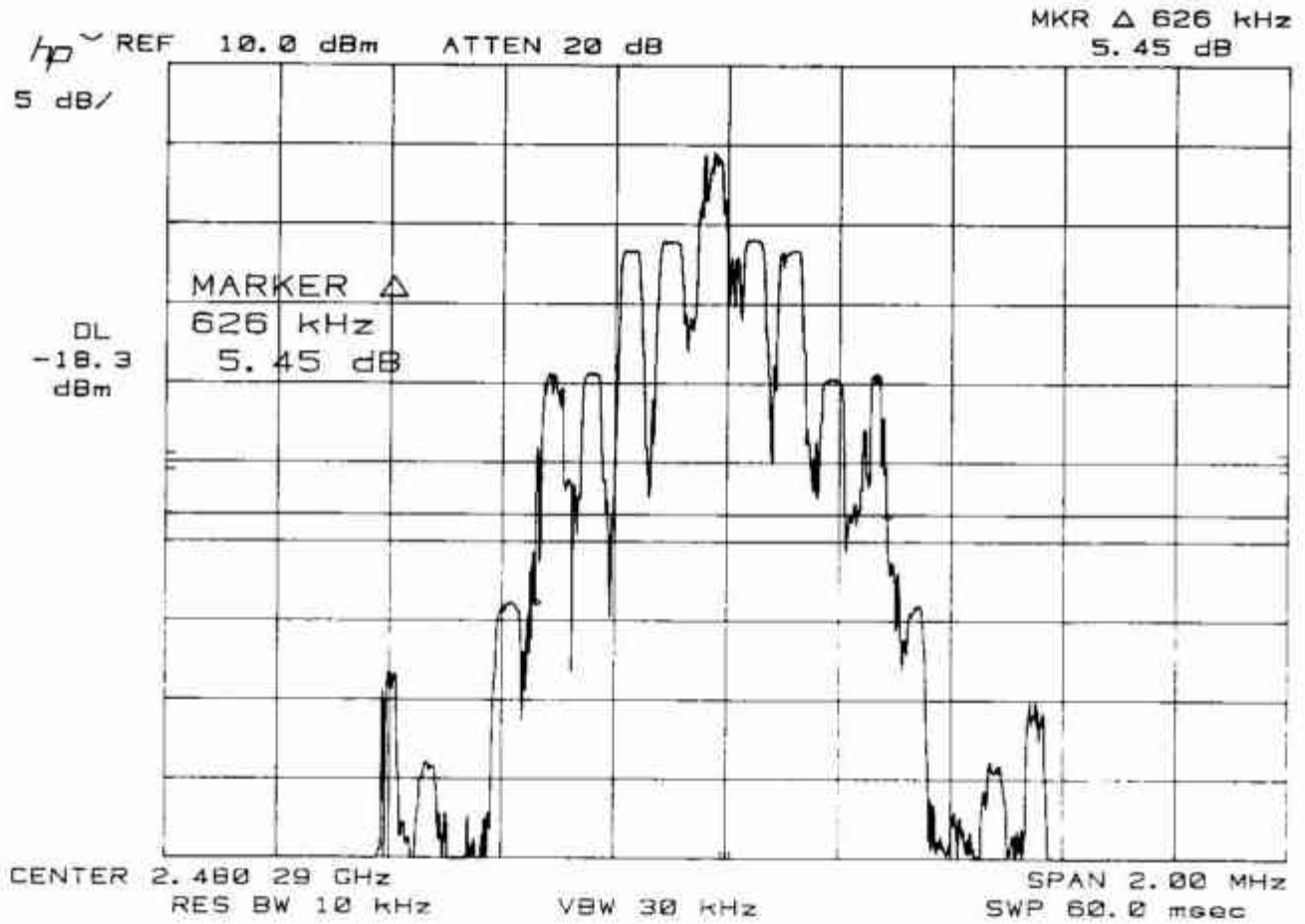

**Band-edge Emission Measurement**

Transmitting Frequency : 2400.916645 MHz (01 ch)  
Band-edge Frequency : 2400.000 MHz

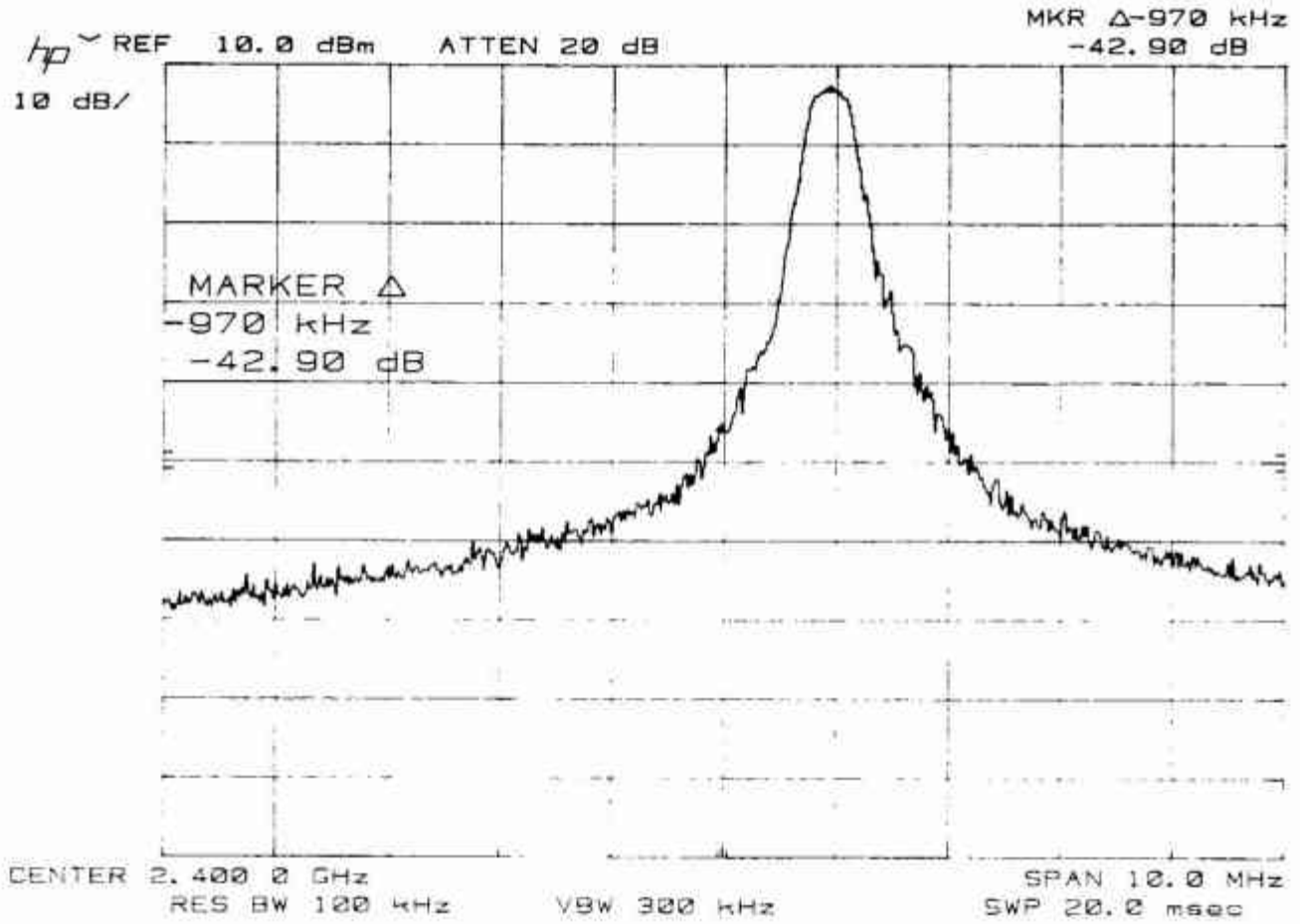

**Band-edge Emission Measurement**

Transmitting Frequency : 2480.158968 MHz (90 ch)  
Band-edge Frequency : 2483.500 MHz

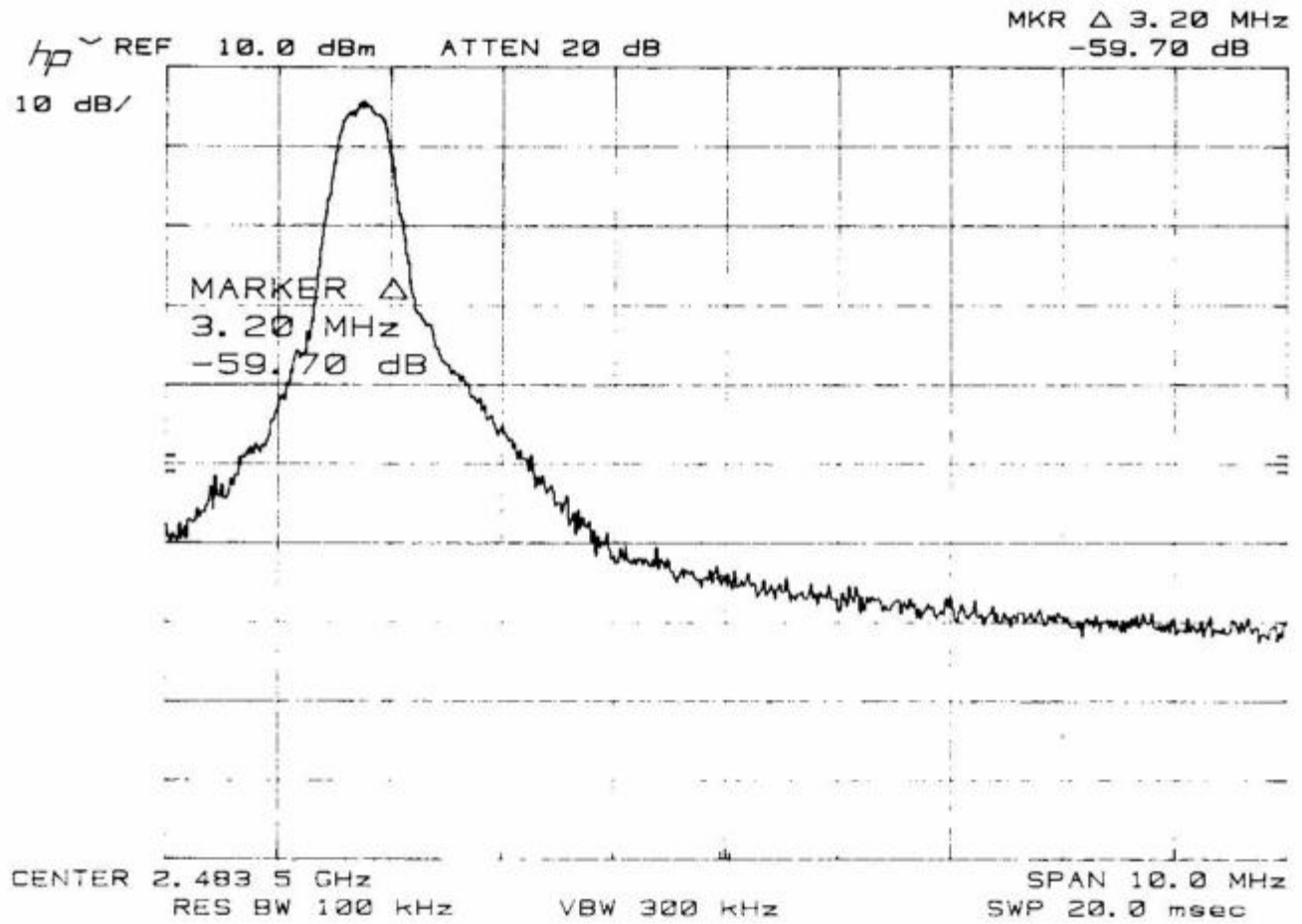

## Carrier Frequency Separation Measurement Fundamental Emission

Test Date: December 4, 2001  
Temp.: 23 °C ; Humi.: 48 %

### Measurement Results:

Transmitting Frequency No.1 : 2440.158968 MHz (45 ch)  
Transmitting Frequency No.2 : 2441.050839 MHz (46 ch)  
Channel Separation : 890 kHz  
Attached Graph Page : page 43

Tester : Yasuhisa Sakai

Carrier Frequency Separation Measurement

Transmitting Frequency No.1 : 2440.158968 MHz (45 ch)  
Transmitting Frequency No.2 : 2441.050839 MHz (46 ch)

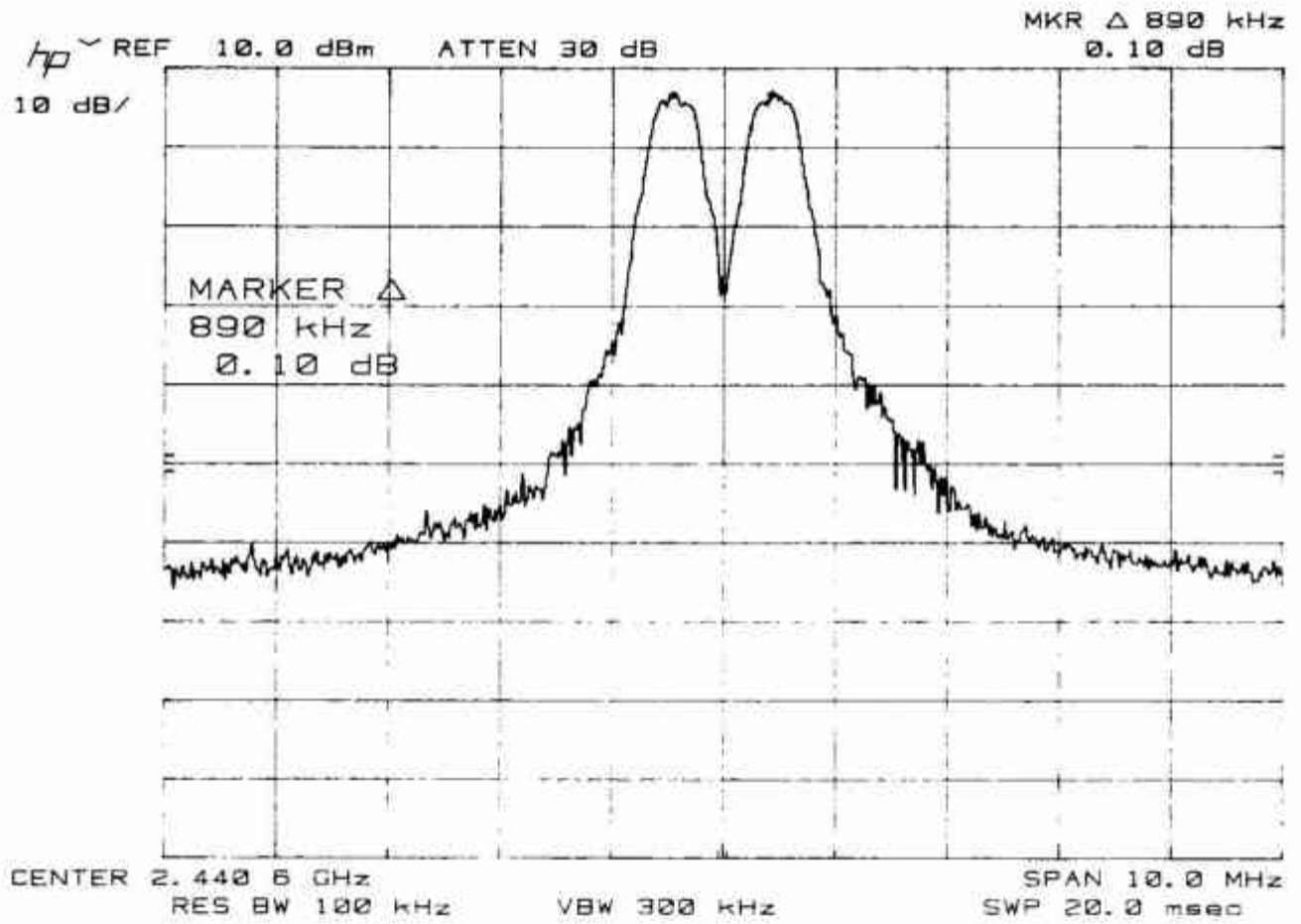

## Sec.247(a)(1)(ii) CHANNEL SEPARATION/DWELL TIME

Compliance with other provision of Sec.15.247 is stated in Kyushu Matsushita Electric Co., Ltd., as stated below:

Hopping channel carrier frequencies are separated by 891.871 kHz.

Each bearer is independent and hops at a rate of 100 hops/sec.

The hopping sequence is either table-generated or RNG-generated:

1. A table-generated hop sequence is 75 hops long, each channel is used exactly once in the sequence. Therefore, in a 30 second period each frequency channel is used 40 times in that sequence.
2. An RNG-generated hop sequence is 3000 hops long, each channel is used exactly 40 times in the entire sequence. Therefore, in a 30 second period each frequency channel is used exactly 40 times in that sequence.

The hopping sequence contains 75 logical channels these are mapped-onto 75 physical channels using a mapping table.

The highest channel occupancy is when an FP has 4 traffic bearers (i.e. 8 slots utilized), each using the same hopping sequence. As shown previously, for a given sequence, in a 30 second period each frequency channel is exactly 40 times. A slot is 1.01 msec. long, therefore the average time of occupancy on any frequency channel in a 30 second period is:

$$T = 1.01 \text{ msec.} \times 40 \times 8 = 323.20 \text{ msec.}$$

As a comparison, the lowest channel occupancy is when only a single dummy bearer is being transmitted. The transmission is 1.01 msec. long, therefore the average time of occupancy on any frequency channel in a 30 second period is:

$$T = 1.01 \text{ msec.} \times 40 \times 1 = 40.4 \text{ msec.}$$

### Sec.15.247(g)

In the case of the dummy bearer (which the FP transmits all the time it is powered up and operating), the hopping sequence cycles through the 75 hops in the selected hopping pattern and then repeats.

In the case of a traffic bearer presented with continuous data (which is the normal case, as this is a voice system), the hopping sequence cycles through the 3000 hops in the sequence and then repeats.

In the case of a traffic bearer transmitting short bursts (for example, which may happen if a PP has several failed attempts<sup>1</sup> to establish a traffic bearer), then the successive traffic bearers will start on different patterns (because the PSTN is incremented each frame).

Note, that this system is a voice system and short burst transmissions are not typical.

1 The protocol actually limits the number of re-tries to 11 before giving up on the connection.

### Sec.15.247(h)

There is no coordination between transmitters for the purpose of the avoiding the simultaneous occupancy of hopping frequencies by multiple transmitters.

Communication only ever takes place between an FP and a PP, never between two FPs (It is actually impossible for an FP to receive an FP packet, because their respective 'sync-fields' are different).

An FP and a PP that have an active traffic bearer between them will share a common hopping sequence and hop sequence adaption information (i.e. 'swapped channels'). However, neither the FP nor the PP transmits this information to a 3rd party, for any purpose whatsoever.

This is even true when in a state of bearer hand-over, where the PP is simultaneously 'locked-onto' two FPs. The PP will know both FP's hopping sequences, but it does not share this information with either FP.

In actual fact, channel collisions between FPs and PPs can and will take place. These may result in reduced voice quality, but this has to be tolerated.

In the case of 'sequence collision' (where two transmitters, with overlapping radio cells, are using the same slot, pattern and phase within the pattern), this is detected by multiple consecutive corrupted packets. Each connection that is experiencing sequence collision will independently attempt to remedy the situation (either by pattern changing or by bearer hand-over, as discussed previously).