

PCTEST Engineering Laboratory, Inc.

6660-B Dobbin Road • Columbia, MD 21045 • U.S.A.

TEL (410) 290-6652 • FAX (410) 290-6654

<http://www.pctestlab.com>



CERTIFICATE OF COMPLIANCE

Matshushita Electric Industrial Co., Ltd.
1006 Oaza Kadoma
Kadoma, Osaka 571 Japan
Attention: Rich Mullen (PSCD)
N. Yoshizumi-Kyushu MEICL

Dates of Tests: November 15-17, 2000
Test Report S/N: 15.201115583.ACJ
Test Site: PCTEST Lab, Columbia MD

FCC ID

ACJ96NKX-TG2583

APPLICANT

Matshushita Electric Industrial Co., Ltd.

FCC Rule Part(s):	§ 15.247; ANSI C-63.4 (1992)
Classification:	Spread Spectrum Transceiver (DSS)
Max Output Power:	Base - 0.1178 W / Handset - 0.0914 W EIRP
Method/System:	Direct Sequence System (DSS)
Equipment Type:	Cordless Telephone (Base/Handset)
Frequency Range:	2401.5 - 2470.5 MHz (Base/Handset)
Model No(s):	KX-TG2583

This equipment has been shown to be capable of compliance with the applicable technical standards as indicated in the measurement report and was tested in accordance with the measurement procedures specified in ANSI C-63-4.

I attest to the accuracy of data. All measurements reported herein were performed by me or were made under my supervision and are correct to the best of my knowledge and belief. I assume full responsibility for the completeness of these measurements and vouch for the qualifications of all persons taking them.

PCTEST certifies that no party to this application has been denied the FCC benefits pursuant to Section 5301 of the Anti-Drug Abuse Act of 1988, 21 U.S.C. 862.

Randy Ortanez
President & Chief Engineer



2 0 1 1 1 5 5 8 3 . A C J

© 2000 PCTEST Engineering Lab., Inc.

NVLAQ[®]
LAB CODE 100431-0

TABLE OF CONTENTS

SCOPE	1
INTRODUCTION (SITE DESCRIPTION)	2
PRODUCT INFORMATION	3
DESCRIPTION OF TESTS	
A. CONDUCTED EMISSIONS	4
B. RADIATED EMISSIONS	5
C. RESTRICTED BANDS	6
D. ANTENNA REQUIREMENT	7
E. DIRECT SEQUENCE BANDWIDTH	8
F. MAXIMUM PEAK POWER OUTPUT	9
G. POWER DENSITY	10
RADIATED MEASUREMENTS (FUNDAMENTAL & HARMONICS)	11-16
FREQUENCY MEASUREMENTS (SPURIOUS)	17
PROCESSING GAIN	18-21
LIST OF TEST EQUIPMENT	22
CONCLUSION	23
APPENDIX A - LABELLING REQUIREMENTS	24-25
APPENDIX B - PLOTS OF EMISSIONS	26
APPENDIX C - PHOTOGRAPHS OF TEST SET-UP	27
APPENDIX D - EUT PHOTOGRAPHS	28
APPENDIX E - USER'S MANUAL	29

MEASUREMENT REPORT

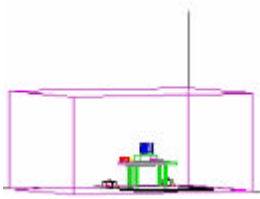

Scope - Measurement and determination of electromagnetic emissions (EME) of radio frequency devices including intentional and/or unintentional radiators for compliance with the technical rules and regulations of the Federal Communications Commission.



§2983(a) General Information

Applicant Name:	Matsushita Electric Industrial Co., Ltd.
Address:	1006 Oaza Kadoma Kadoma, Osaka 571 JAPAN
Attention:	Rich Mullen (PSCD)

- FCC ID: **ACJ96NKX-TG2583**
- Class: Spread Spectrum Transceiver (DSS)
- Type: Cordless Telephone (Base/Handset)
- Freq. Range: 2401.5 – 2470.5 MHz
- Method/System: Direct Sequence System (DSS)
- Model No(s): **KX-TG2583**
- Max. RF Output Power: Base (117.8 mW) / Handset (91.4 mW)
- Power Supply: AC Adapter PQLV10 - Base
3.6 VDC 850mAh NiMh - Handset
- Cable(s): Telco
- USOC Jack: RJ-11
- Rule Part(s): § 15.247
- Dates of Tests: November 15-17, 2000
- Place of Tests: PCTEST Lab, Columbia, MD U.S.A.
- Test Report S/N: 201115583.ACJ

NOTE: The receiver portion was tested and complies with Part 15B under the verification procedure.



INTRODUCTION

The measurement procedure described in American National Standard for Methods of Measurement of Radio-Noise Emissions from Low-Voltage Electrical and Electronic Equipment in the Range of 9kHz to 40GHz (ANSI C63.4-1992) and FCC Public Notice dated July 12, 1995 entitled "Guidance on Measurement for Direct Sequence Spread Spectrum Systems" were used in the measurement of **Panasonic Spread Spectrum** telephone system.

These measurement tests were conducted at **PCTEST Engineering Laboratory, Inc.** facility in New Concept Business Park, Guilford Industrial Park, Columbia, Maryland. The site address is 6660-B Dobbin Road, Columbia, MD 21045. The test site is one of the highest points in the Columbia area with an elevation of 390 feet above mean sea level. The site coordinates are 39° 11'15" N latitude and 76° 49'38" W longitude. The facility is 1.5 miles North of the FCC laboratory, and the ambient signal and ambient signal strength are approximately equal to those of the FCC laboratory. There are no FM or TV transmitters within 15 miles of the site. The detailed description of the measurement facility was found to be in compliance with the requirements of § 2.948 according to ANSI C63.4 on October 19, 1992.

PCTEST Location

The map at right shows the location of the PCTEST Lab, its proximity to the FCC Lab, the Columbia vicinity area, the Baltimore-Washington International (BWI) airport, and the city of Baltimore, and the Washington, D.C. area. (see Figure1).

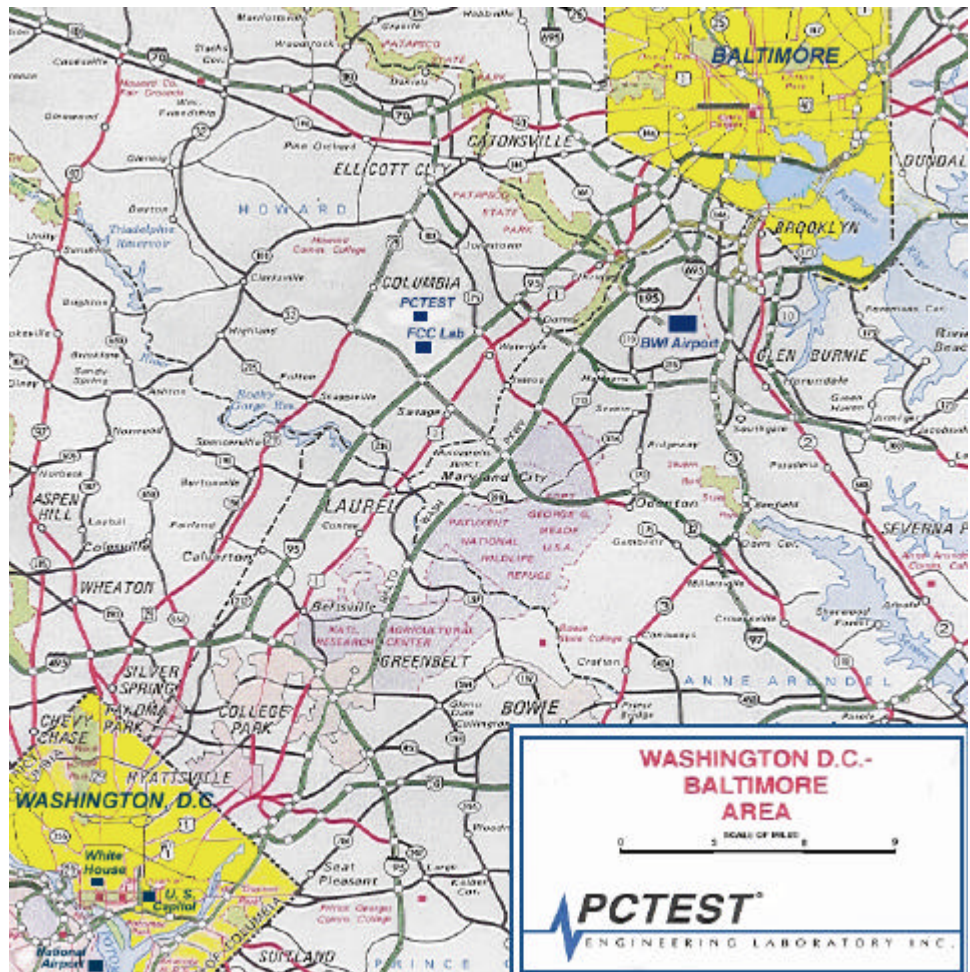

Figure 1. Map of the Greater Baltimore and Metropolitan Washington, D.C. area.

PRODUCT INFORMATION

Equipment Description:

The Equipment under test (EUT) is the **Panasonic** cordless telephone system using spread spectrum direct sequence and time division duplex techniques.

Frequency Range: 2401.5 – 2470.5 MHz
Channels: 24 (Base/handset)
Channel Separation: 3.0 MHz
Spread Spectrum Method: Direct Sequence (DBPSK modulation)
Max RF Output Power: Base (117.8 mW) / Handset (91.4 mW)
Antenna: Omni-directional (base/handset)
Battery: NiMH 2.4VDC 1500Ma
Port/Connector(s): RJ-11C (base)

CH	Rx/Tx Freq. (MHz)	CH	Rx/Tx Freq. (MHz)	CH	Rx/Tx Freq. (MHz)
1	2401.5	9	2425.5	17	2449.5
2	2404.5	10	2428.5	18	2452.5
3	2407.5	11	2431.5	19	2455.5
4	2410.5	12	2434.5	20	2458.5
5	2413.5	13	2437.5	21	2461.5
6	2416.5	14	2440.5	22	2464.5
7	2419.5	15	2443.5	23	2467.5
8	2422.5	16	2446.5	24	2470.5

Description of Tests

Conducted Emissions (Base Unit)

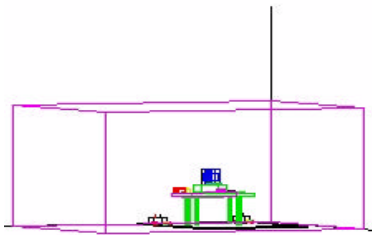

Figure 4. Shielded Enclosure Line-Conducted Test Facility

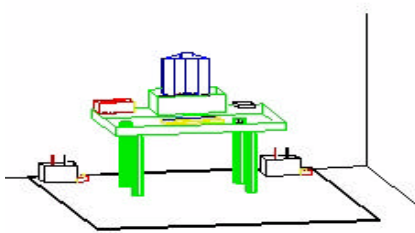

Figure 2. Line Conducted Emission Test Set-Up

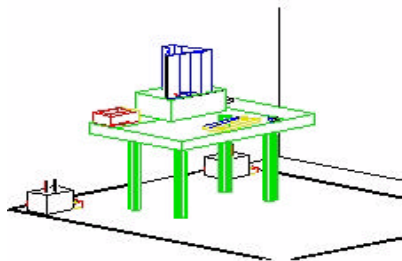

Figure 3. Wooden Table & Bonded LISNs

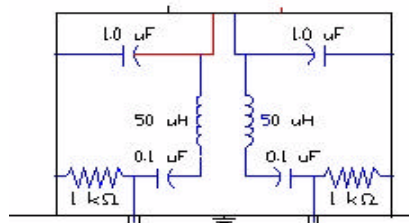

Figure 5. LISN Schematic Diagram

The line-conducted facility is located inside a 16'x20'x10' shielded enclosure. It is manufactured by Ray Proof Series 81 (see Figure 2). The shielding effectiveness of the shielded room is in accordance with MIL-Std-285 or NSA 65-6. A 1m. x 1.5m. wooden table 80cm. high is placed 40cm. away from the vertical wall and 1.5m away from the side wall of the shielded room (see Figure 3). Solar Electronics and EMCO Model 3725/2 (10kHz-30MHz) 50Ω/50μH Line-Impedance Stabilization Networks (LISNs) are bonded to the shielded room (see Figure 4). The EUT is powered from the Solar LISN and the support equipment is powered from the EMCO LISN. Power to the LISNs are filtered by a high-current high-insertion loss Ray Proof power line filters (100dB 14kHz-10GHz). The purpose of the filter is to attenuate ambient signal interference and this filter is also bonded to the shielded enclosure. All electrical cables are shielded by braided tinned copper zipper tubing with inner diameter of 1/2". If the EUT is a DC-powered device, power will be derived from the source power supply it normally will be powered from and this supply lines will be connected to the Solar LISN. LISN schematic diagram is shown in Figure 5. All interconnecting cables more than 1 meter were shortened by non-inductive bundling (serpentine fashion) to a 1-meter length. Sufficient time for the EUT, support equipment, and test equipment was allowed in order for them to warm up to their normal operating condition. The RF output of the LISN was connected to the spectrum analyzer to determine the frequency producing the maximum EME from the EUT. The spectrum was scanned from 450kHz to 30MHz with 20 msec. sweep time. The frequency producing the maximum level was reexamined using EMI/ Field Intensity Meter and Quasi-Peak adapter. The detector function was set to CISPR quasi-peak mode. The bandwidth of the receiver was set to 10 kHz. The EUT, support equipment, and interconnecting cables were arranged and manipulated to maximize each EME emission. Each emission was maximized by: switching power lines; varying the mode of operation or resolution; clock or data exchange speed; scrolling H pattern to the EUT and/or support equipment, and powering the monitor from the floor mounted outlet box and the computer aux AC outlet, if applicable; whichever determined the worst-case emission. Photographs of the worst-case emission can be seen in Appendix C. Each EME reported was calibrated using the HP8640B signal generator.

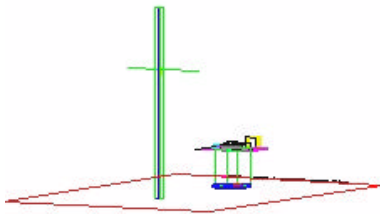

Figure 6. 3-Meter Test Site

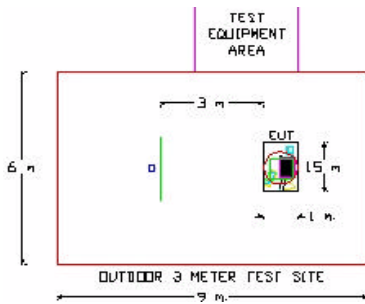

Figure 7. Dimensions of Outdoor Test Site

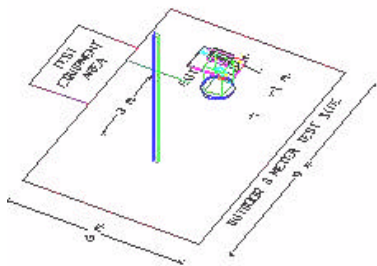

Figure 8. Turntable and System Setup

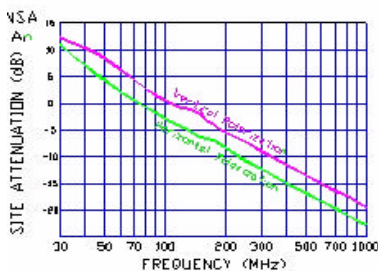

Figure 9. Normalized Site Attenuation Curves (H&V)

description of tests (Continued)

Radiated Emissions (Base & Handset)

Preliminary measurements were made indoors at 1 meter using broadband antennas, broadband amplifier, and spectrum analyzer to determine the frequency producing the maximum EME. Appropriate precaution was taken to ensure that all EME from the EUT were maximized and investigated. The system configuration, clock speed, mode of operation or video resolution, turntable azimuth with respect to the antenna were noted for each frequency found. The spectrum was scanned from 30 to 200 MHz using biconical antenna and from 200 to 1000 MHz using log-spiral antenna. Above 1 GHz, linearly polarized double ridge horn antennas were used.

Final measurements were made outdoors at 3-meter test range using Roberts™ Dipole antennas or horn antenna (see Figure 6). The test equipment was placed on a wooden and plastic bench situated on a 1.5 x 2 meter area adjacent to the measurement area (see Figure 7). Sufficient time for the EUT, support equipment, and test equipment was allowed in order for them to warm up to their normal operating condition. Each frequency found during pre-scan measurements was re-examined and investigated using EMI/Field Intensity Meter and Quasi-Peak Adapter. The detector function was set to CISPR quasi-peak mode and the bandwidth of the receiver was set to 100kHz or 1 MHz depending on the frequency or type of signal.

The half-wave dipole antenna was tuned to the frequency found during preliminary radiated measurements. The EUT, support equipment and interconnecting cables were re-configured to the set-up producing the maximum emission for the frequency and were placed on top of a 0.8-meter high non-metallic 1 x 1.5 meter table (see Figure 8). The EUT, support equipment, and interconnecting cables were re-arranged and manipulated to maximize each EME emission. The turntable containing the system was rotated; the antenna height was varied 1 to 4 meters and stopped at the azimuth or height producing the maximum emission. Each emission was maximized by: varying the mode of operation or resolution; clock or data exchange speed; scrolling H pattern to the EUT and/or support equipment, and powering the monitor from the floor mounted outlet box and the computer aux AC outlet, if applicable; and changing the polarity of the antenna, whichever determined the worst-case emission. Photographs of the worst-case emission can be seen in Appendix C. Each EME reported was calibrated using the HP8640B signal generator. The Theoretical Normalized Site Attenuation Curves for both horizontal and vertical polarization are shown in Figure 9.

§ 15.205 Restricted Bands

Special attention is made for the EUT's harmonic and spurious radiated emission in the restricted bands of operation. The EUT was tested from 9kHz and up to the tenth harmonic of the fundamental frequency of the transmitter using CISPR quasi peak detector below 1GHz. Above 1 GHz, average measurements was used using RBW 1 MHz – VBW 10Hz and linearly polarized horn antennas. In addition, peak measurements were taken to ensure that the peak levels are not more than 20dB above the average limit. All out of band emissions, other than those created by the spreading sequency, data sequence, and the carrier modulation must not exceed the limits show int Table 2 per 15.209.

Frequency (MHz)	F/S (UV/m)	Meas. Dist. (Meters)
0.009-0.490	2400/F (kHz)	300
0.490-1.705	24000/F (kHz)	30
1.705-30.00	30	30
30.0-88.0	100	3
88.0-216.0	150	3
216.0-960.0	200	3
Above 960	500	3

Tab. 2. Radiated Emission Limits Per 15.209

Test Equipment

HP 8566B	Spectrum Analyzer 100Hz-22HGHz
HP83017A	Microwave Analyzer 40dB Gain (0.5 – 26.5 GHz)
HP 3784A	Digital Transmission Analyzer
EMCO 3115	Horn Antenna (1 – 18GHz)
HP 8495A	20dB Attenuator (DC-40GHz) 0-70dB
HP 8493B	10dB Attenuator
MicroCoax Cables	Low Loss Microwave Cables (1-26.5 GHz)
CDI Dipoles	Dipole Antennas (30 – 1000 MHz)

§ 15.203 Antenna Requirement

An intentional radiator antenna shall be designed to ensure that no antenna other than that furnished by the applicant can be used with the device. The use of a permanently attached antenna or of an antenna that uses a unique coupling to the intentional radiator shall be considered sufficient to comply with this requirement.

Base Unit

The Panasonic **KX-TG2583** base unit complies with the requirement of §15.203. The antenna is a **permanently attached omni-directional antenna**.

Handset Unit

The Panasonic **KX-TG2583** handset unit complies with the requirement of §15.203.

CONCLUSION

For both units, there are no provisions for connection to an external antenna. Both Base and Handset units meet the Antenna Requirements of §15.203.

§15.247(a)(2) – Direct Sequence Bandwidth

Minimum Standard – 6dB bandwidth for direct sequence systems must be at least 500Hz (0.5 MHz).

Res. Bandwidth = 100 kHz (5dB/div)
Vid. BW = 100 kHz
Span = 5 MHz
Ref. Level - 30 dBm
Sweep 10ms
Attenuator 0 dB ext. pad
6dB Bandwidth –Mkr Delta (6dB down from peak)
(see attached spectrum plots)

FREQ (MHz)	Base/Handset (B/H)	Channel	6dB Bandwidth (MHz)
2401.5	B	1	1.683
2434.5	B	12	1.718
2470.5	B	24	1.728
2401.5	H	1	1.939
2434.5	H	12	1.999
2470.5	H	24	1.994

Table 3. 6dB Bandwidth measurements

REMARKS:
PASS

§15.247(b) Maximum Peak Output Power

Minimum Standard – The maximum peak output power of the transmitter shall not exceed 1 watt.

Res. Bandwidth = 3 MHz (10dB/div)
Vid. BW = 3 MHz
Span = 10 MHz
Ref. Level -20 dBm
Sweep 5 ms sec
Attenuator 0 dB ext. pad

Max. Power Peak + Atten = dBm \Rightarrow Watts

FREQ (MHz)	Base/Handset (B/H)	Channel	Power Output (dBm)	Power Output (mW)
2401.5	B	1	18.80	75.88
2434.5	B	12	20.99	117.66
2470.5	B	24	20.08	101.88
2401.5	H	1	18.87	77.11
2434.5	H	12	19.89	91.43
2470.5	H	24	16.79	47.76

Table 4. Output Power Measurements

REMARKS:

PASS

§15.247(c) Power Density

Minimum Standard – The transmitted power density averaged over any 1 second interval shall not be greater than 8dBm in any 3kHz bandwidth within these bands.

Res. Bandwidth = 3 kHz (10dB/div)
Vid. BW = 3 kHz
Span = 300 kHz (3.0 MHz)
Ref. Level - 20 dBm
Sweep 1000 sec

Peak + Atten = dBm ⇒ (Limit < 8dBm)

FREQ (MHz)	Base/Handset (B/H)	Channel	Power Density (dBm)
2406.16	B	1	5.01
2441.52	B	12	6.23
2477.84	B	24	6.77
2406.16	H	1	5.49
2441.52	H	12	6.97
2477.84	H	24	2.21

Table 5. Output Power Density Data.

REMARKS:

PASS

RADIATED Measurements (Fundamental & Harmonics)

A. Transmitter Portion (Base)

Operating Frequency: 2401.5 MHz
 Distance of Measurements: 3 meters
 Channel: 1

FREQ. (MHz)	Level* (dBm)	AFCL (dB)	POL (H/V)	DET QP/AVG	F/S (μ V/m)	F/S (dB μ V/m)	Margin (dB)
2401.5	- 25.7	32.7	V	Peak	502921.3	114.0	n/a
4803.0	- 99.4	40.4	V	Peak	250.900	48.0	6.0
7204.5	- 119.2	47.4	V	Peak	57.677	35.2	78.8
9606.0	< - 120						
12007.5	< - 120						

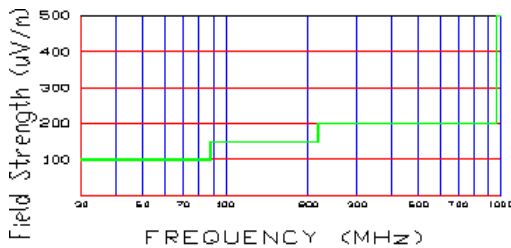

Figure 10. Restricted band harmonics and spurious limits.

Above 1 GHz limit is 500 uV/m (54dBu/m)

NOTES:

- All harmonics in the restricted bands specified in §15.205 are below the limit shown in table 2. (note: * Restricted Band)
- All harmonics/spurs are at least 20 dB below the highest emission in the authorized band using RBW = 100kHz
- Average Measurements > 1GHz using RBW = 1 MHz VBW = 10 Hz
- The peak emissions above 1 GHz are not more than 20 dB above the average limit.
- The antenna is manipulated through typical positions, polarity and length during the tests.
- The EUT is supplied with nominal AC voltage or/and a new/fully recharged battery.
- The spectrum is measured from 9kHz to the 10th harmonic and the worst-case emissions are reported.
- < - 120 are below the analyzer floor level.

RADIATED Measurements (Fundamental & Harmonics) (CONT.)

B. Transmitter Portion (Base)

Operating Frequency: 2434.5 MHz
 Distance of Measurements: 3 meters
 Channel: 12

FREQ. (MHz)	Level* (dBm)	AFCL (dB)	POL (H/V)	DET QP/AVG	F/S (μ V/m)	F/S (dB μ V/m)	Margin (dB)
2434.5	- 23.6	32.8	V	Peak	647142.6	116.2	n/a
4869.0	- 98.5	40.5	V	Peak	281.838	49.0	5.0
7303.5	- 117.5	48.0	V	Peak	74.989	37.5	16.5
9738.0	< - 120						
12172.5	< - 120						

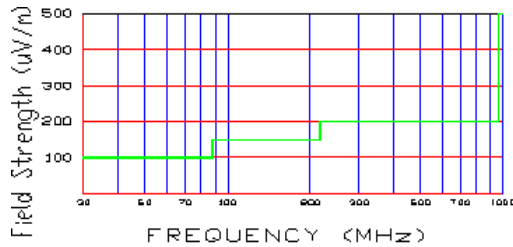

Figure 10. Restricted band harmonics and spurious limits.

Above 1 GHz limit is 500 uV/m (54dBu/m)

NOTES:

1. All harmonics in the restricted bands specified in §15.205 are below the limit shown in table 2. (note: * Restricted Band)
2. All harmonics/spurs are at least 20 dB below the highest emission in the authorized band using RBW = 100kHz
3. Average Measurements > 1GHz using RBW = 1 MHz VBW = 10 Hz
4. The peak emissions above 1 GHz are not more than 20 dB above the average limit.
5. The antenna is manipulated through typical positions, polarity and length during the tests.
6. The EUT is supplied with nominal AC voltage or/and a new/fully recharged battery.
7. The spectrum is measured from 9kHz to the 10th harmonic and the worst-case emissions are reported.
8. < - 120 are below the analyzer floor level.

RADIATED Measurements (Fundamental & Harmonics) (CONT.)

C. Transmitter Portion (Base)

Operating Frequency: 2470.5 MHz
 Distance of Measurements: 3 meters
 Channel: 24

FREQ. (MHz)	Level* (dBm)	AFCL (dB)	POL (H/V)	DET QP/AVG	F/S (μ V/m)	F/S (dB μ V/m)	Margin (dB)
2470.5	- 24.6	32.9	V	Peak	582773.8	115.3	n/a
4941.0	- 99.0	40.7	V	Peak	272.270	48.7	5.3
7411.5	- 116.9	48.2	V	Peak	82.224	38.3	15.7
9882.0	< - 120						
12352.5	< - 120						

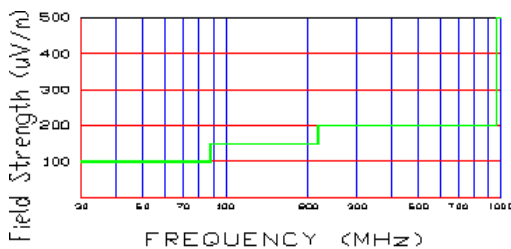

Figure 10. Restricted band harmonics and spurious limits.

Above 1 GHz limit is 500 uV/m (54dBu/m)

NOTES:

1. All harmonics in the restricted bands specified in §15.205 are below the limit shown in table 2. (note: * Restricted Band)
2. All harmonics/spurs are at least 20 dB below the highest emission in the authorized band using RBW = 100kHz
3. Average Measurements > 1GHz using RBW = 1 MHz VBW = 10 Hz
4. The peak emissions above 1 GHz are not more than 20 dB above the average limit.
5. The antenna is manipulated through typical positions, polarity and length during the tests.
6. The EUT is supplied with nominal AC voltage or/and a new/fully recharged battery.
7. The spectrum is measured from 9kHz to the 10th harmonic and the worst-case emissions are reported.
8. < - 120 are below the analyzer floor level.

RADIATED Measurements (Fundamental & Harmonics) (CONT.)

D. Transmitter Portion (Handset)

Operating Frequency: 2401.5 MHz
 Distance of Measurements: 3 meters
 Channel: 1

FREQ. (MHz)	Level* (dBm)	AFCL (dB)	POL (H/V)	DET QP/AVG	F/S (μ V/m)	F/S (dB μ V/m)	Margin (dB)
2401.5	- 25.6	32.7	V	Peak	506990.7	114.1	n/a
4803.0	- 97.4	40.4	V	Peak	315.864	50.0	4.0
7204.5	- 117.2	47.4	V	Peak	72.611	37.2	76.9
9606.0	< - 120						
12007.5	< - 120						

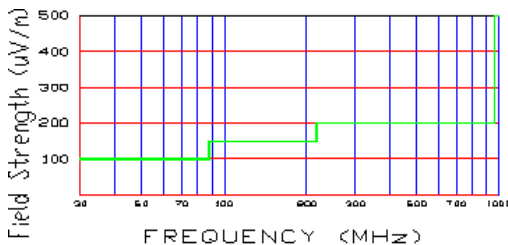

Figure 10. Restricted band harmonics and spurious limits.

Above 1 GHz limit is 500 uV/m (54dBu/m)

NOTES:

1. All harmonics in the restricted bands specified in §15.205 are below the limit shown in table 2. (note: * Restricted Band)
2. All harmonics/spurs are at least 20 dB below the highest emission in the authorized band using RBW = 100kHz
3. Average Measurements > 1GHz using RBW = 1 MHz VBW = 10 Hz
4. The peak emissions above 1 GHz are not more than 20 dB above the average limit.
5. The antenna is manipulated through typical positions, polarity and length during the tests.
6. The EUT is supplied with nominal AC voltage or/and a new/fully recharged battery.
7. The spectrum is measured from 9kHz to the 10th harmonic and the worst-case emissions are reported.
8. < - 120 are below the analyzer floor level.

RADIATED Measurements (Fundamental & Harmonics) (CONT.)

E. Transmitter Portion (Handset)

Operating Frequency: 2434.5 MHz
 Distance of Measurements: 3 meters
 Channel: 12

FREQ. (MHz)	Level* (dBm)	AFCL (dB)	POL (H/V)	DET QP/AVG	F/S (μ V/m)	F/S (dB μ V/m)	Margin (dB)
2434.5	- 24.7	32.8	V	Peak	570164.3	115.1	n/a
4869.0	- 98.3	40.5	V	Peak	286.979	49.2	4.8
7303.5	- 117.1	48.0	V	Peak	78.524	37.9	16.1
9738.0	< - 120						
12172.5	< - 120						

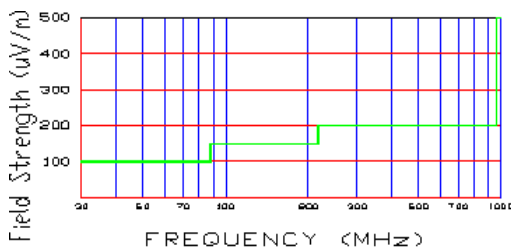

Figure 10. Restricted band harmonics and spurious limits.

Above 1 GHz limit is 500 uV/m (54dBu/m)

NOTES:

- All harmonics in the restricted bands specified in §15.205 are below the limit shown in table 2. (note: * Restricted Band)
- All harmonics/spurs are at least 20 dB below the highest emission in the authorized band using RBW = 100kHz
- Average Measurements > 1GHz using RBW = 1 MHz VBW = 10 Hz
- The peak emissions above 1 GHz are not more than 20 dB above the average limit.
- The antenna is manipulated through typical positions, polarity and length during the tests.
- The EUT is supplied with nominal AC voltage or/and a new/fully recharged battery.
- The spectrum is measured from 9kHz to the 10th harmonic and the worst-case emissions are reported.
- < - 120 are below the analyzer floor level.

RADIATED Measurements (Fundamental & Harmonics) (CONT.)

F. Transmitter Portion (Handset)

Operating Frequency: 2470.5 MHz
 Distance of Measurements: 3 meters
 Channel: 24

FREQ. (MHz)	Level* (dBm)	AFCL (dB)	POL (H/V)	DET QP/AVG	F/S (μ V/m)	F/S (dB μ V/m)	Margin (dB)
2470.5	- 27.9	32.9	V	Peak	399024.9	112.0	n/a
4941.0	- 99.2	40.7	V	Peak	265.155	48.5	5.5
7411.5	- 118.2	48.2	V	Peak	70.795	37.0	17.0
9882.0	< - 120						
12352.5	< - 120						

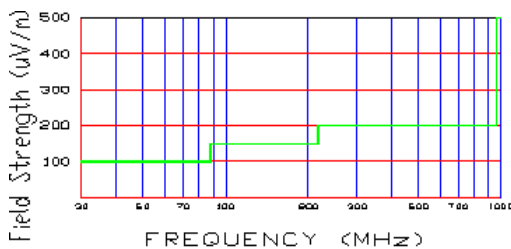

Figure 10. Restricted band harmonics and spurious limits.

Above 1 GHz limit is 500 uV/m (54dBu/m)

NOTES:

1. All harmonics in the restricted bands specified in §15.205 are below the limit shown in table 2. (note: * Restricted Band)
2. All harmonics/spurs are at least 20 dB below the highest emission in the authorized band using RBW = 100kHz
3. Average Measurements > 1GHz using RBW = 1 MHz VBW = 10 Hz
4. The peak emissions above 1 GHz are not more than 20 dB above the average limit.
5. The antenna is manipulated through typical positions, polarity and length during the tests.
6. The EUT is supplied with nominal AC voltage or/and a new/fully recharged battery.
7. The spectrum is measured from 9kHz to the 10th harmonic and the worst-case emissions are reported.
8. < - 120 are below the analyzer floor level.

RADIATED Measurements (Spurious)

A. Transmitter Portion (Base/Handset)

Operating Frequency: 2401.5 – 2470.5 MHz
 Distance of Measurements: 3 meters
 Channel: 1, 12, 24

FREQ. (MHz)	Level* (dBm)	AFCL (dB)	POL (H/V)	F/S (μ V/m)	DET QP/AVG	Margin (dB)
147.2	- 84.7	13.4	H	61.0	QP	- 7.8
175.4	- 85.2	13.5	V	58.3	QP	- 8.2
240.7	- 90.9	18.4	V	53.1	QP	- 11.5
368.2	- 92.8	22.8	V	70.8	QP	- 9.0
442.3	- 95.9	24.7	V	61.7	QP	- 10.2
579.3	- 98.2	27.7	H	66.9	QP	- 9.5

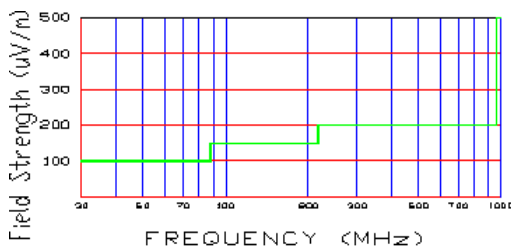

Figure 10. Restricted band harmonics and spurious limits.

Above 1 GHz limit is 500 uV/m (54dBu/m)

NOTES:

1. All emissions were investigated and the worst case emissions are reported
2. For hand-held devices, the EUT is rotated through three orthogonal axis to determine which configuration produces the maximum emissions
3. The EUT is supplied with the minimal AC voltage or/and a new/fully recharged battery.
4. The EUT was tested up to the 10th harmonic (9.3 GHz) and no significant emission was found.

§15.247(e) Processing Gain (from Panasonic)

I. Requirements

According to the FCC requirement 15.247 for direct sequence spread spectrum systems, the minimum processing gain is 10 dB. The CW jamming margin method was used to determine the KX-TG2583 processing gain. The processing gain was calculated using the following equation:

$$G_p = (S/N)_o + M_j + L_{sys} \text{ where:}$$

G_p = Processing Gain

$(S/N)_o$ = Signal to noise required for a given error probability. In this case 1×10^{-4} was used.

M_j = J/S Jammer to signal ratio required to produce given error probability.

L_{sys} = System losses to due non-ideal performance. Maximum allowed by the FCC is **2.0 dB**.

The $(S/N)_o$ ratio was determined to be **11.0 dB** according to Jakes "Microwave Mobile Communications". Page 229 indicates the relevant curve showing error probability Vs $(S/N)_o$ for a non-coherent FM system with a peak deviation equal to .35 of the modulation frequency:
 $F_d = .35 F_m$.

Given a minimum processing gain of 10 dB, the minimum allowable J/S ratio is -3.0 dB.

II. Test Setup

The processing gain was measured using the test setup shown in Figure 1:

The following test equipment was used for this setup:

- KX-TG2583 (Equipment under test)
- Dummy Set: Used KX-TG2583 evaluation set.
- IFR 2051 Signal Generator (for desire signal)
- Hewlett Packard ESG D3000A Signal Generator (for jamming signal)
- Taisei SPL1141 Coupler
- Japan Radio Co Ltd.(JRC) NJZ-940 TDMA Error Ratio Measuring Equipment (BER tester)
- Semiflex SMA cables

The Dummy Set was set up at the middle channel 2.4345 GHz. The KX-TG2583 base band 3dB bandwidth is less than 1.0 MHz; therefore, the signal generator was used to inject a CW jammer from 2.4335 GHz to 2.4355 GHz in 50 kHz increments. The DUT received input power was set at -70 dBm. The jammer power was adjusted to achieve a bit error rate of 1×10^{-4} at each jammer frequency. The jammer power was recorded and the processing gain calculated for each jammer frequency from 2.4335 GHz to 2.4355 GHz.

III. Test Results

The processing gain Vs jammer frequency is shown in Figure 2 and Figure 3 :

\$15.247(e) Processing Gain (from Panasonic)

$$G_p = (C/N)_0 + M_j + L_{sys}$$

G_p = KX-TG2583 Process Gain

$(S/N)_0$ = S/N ratio for keeping BER=1x10⁻⁴

$(S/N)_0$ is 11dB on this system.

M_j = J/S ratio (CW Jamming margin method)

L_{sys} = system loss (<=2.0dB)

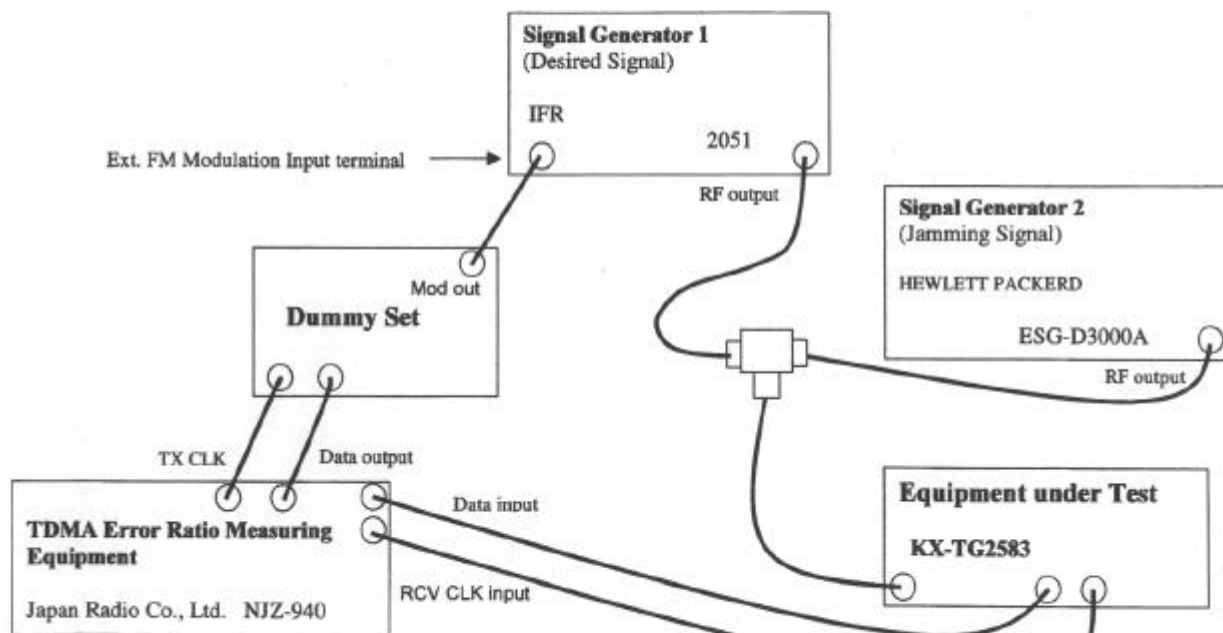

Figure 1: Processing Gain Test Setup

§15.247(e) Processing Gain (from Panasonic)

KX-TG2583 Processing Gain Test Results

Kyushu Matsushita Electric Co., Ltd.,

Telephone Engineering Department/
 Telecom Division

Hideki Takao

	Portable Unit	Base Unit
	KX-TG2670N-R	KX-TG2670N-H
Δf (kHz)	J/S Ratio (dB)	J/S Ratio (dB)
1000	8.5	8.4
950	6.5	6.2
900	4.3	4.3
850	2.9	2.7
800	0.7	0.8
750	-0.8	-0.5
700	-1.1	-1.3
650	-1.4	-1.5
600	-1.4	-1.6
550	-1.3	-1.5
500	-1.0	-1.4
450	-0.9	-1.4
400	-0.8	-1.2
350	-0.9	-1.3
300	-0.9	-1.0
250	-0.8	-0.9
200	-0.3	-0.8
150	-0.1	-0.8
100	-0.2	-1.0
50	-1.0	-0.3
0	0.3	0.1
-50	0.5	0.0
-100	-1.3	-1.3
-150	-0.6	-0.8
-200	0.0	-0.8
-250	-0.4	-0.8
-300	-0.5	-0.9
-350	-0.5	-1.3
-400	-0.8	-1.3
-450	-1.0	-1.4
-500	-1.1	-1.6
-550	-1.5	-1.7
-600	-1.6	-1.8
-650	-1.4	-1.8
-700	-1.2	-1.8
-750	-0.8	-1.3
-800	0.3	-0.2
-850	1.9	1.2
-900	4.2	3.3
-950	6.5	5.2
-1000	8.3	7.8

J/S Ratio = (Jammer Signal) / (Desired Signal) Ratio

= worst 20% points

These points are excluded.

Mj Jamming Margin

Mj(J/S ratio)	
Portable	-1.1dB
Base	-1.4dB

Note: Mj level is worst value after exclude worst 20% points.

Process Gain

$$G_p = (S/N)_o + M_j + L_{sys}$$

$$(S/N)_o = 11\text{dB}$$

$$L_{sys} = 2.0\text{dB}$$

Mj: compare above table.

Gp (Process Gain)		
Portable	11.9dB	(=-1.1+11+2)
Base	11.6dB	(=-1.4+11+2)

Figure 2: Test Results of Process Gain

§15.247(e) Processing Gain (from Panasonic)

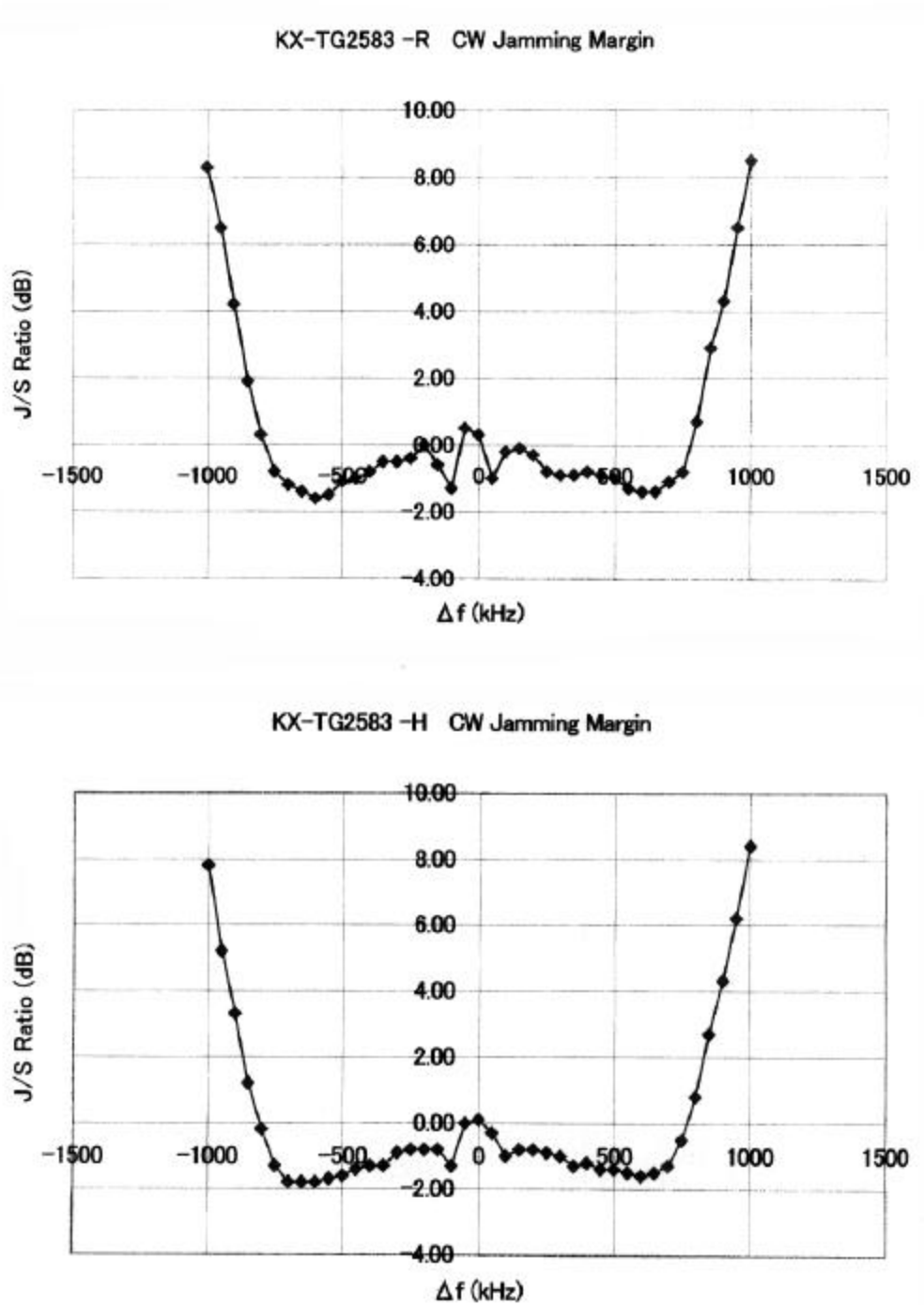

Figure 3: Test Results of Jamming Margin

TEST EQUIPMENT

Type	Model	Cal. Due Date	S/N
Microwave Spectrum Analyzer	HP 8566B (100Hz-22GHz)	12/05/00	3638A08713
Microwave Spectrum Analyzer	HP 8566B (100Hz-22GHz)	04/17/01	2542A11898
Spectrum Analyzer/Tracking Gen.	HP 8591A (9kHz-1.8GHz)	06/02/01	3144A02458
Spectrum Analyzer	HP 8591A (9kHz-1.8GHz)	10/15/01	3108A02053
Spectrum Analyzer	HP 8594A (9kHz-2.9GHz)	11/02/01	3051A00187
Signal Generator*	HP 8640B (500Hz-1GHz)	06/02/01	2232A19558
Signal Generator*	HP 8640B (500Hz-1GHz)	06/02/01	1851A09816
Signal Generator*	Rohde & Schwarz (0.1-1000MHz)	09/11/01	894215/012
Ailtech/Eaton Receiver	NM 37/57A-SL (30-1000MHz)	04/12/01	0792-03271
Ailtech/Eaton Receiver	NM 37/57A (30-1000MHz)	03/11/01	0805-03334
Ailtech/Eaton Receiver	NM 17/27A (0.1-32MHz)	09/17/01	0608-03241
Quasi-Peak Adapter	HP 85650A	08/09/01	2043A00301
Ailtech/Eaton Adapter	CCA-7 CISPR/ANSI QP Adapter	03/11/01	0194-04082
RG58 Coax Test Cable	No. 167		n/a
Harmonic/Flicker Test System	HP 6841A (IEC 555-2/3)		3531A00115
Broadband Amplifier (2)	HP 8447D		1145A00470, 1937A03348
Broadband Amplifier	HP 8447F		2443A03784
Transient Limiter	HP 11947A (9kHz-200MHz)		2820A00300
Horn Antenna	EMCO Model 3115 (1-18GHz)		9704-5182
Horn Antenna	EMCO Model 3115 (1-18GHz)		9205-3874
Horn Antenna	EMCO Model 3116 (18-40GHz)		9203-2178
Biconical Antenna (4)	Eaton 94455/Eaton 94455-1/Singer 94455-1/Compliance Design		1295, 1332, 0355
Log-Spiral Antenna (3)	Ailtech/Eaton 93490-1		0608, 1103, 1104
Roberts Dipoles	Compliance Design (1 set) A100		5118
Ailtech Dipoles	DM-105A (1 set)		33448-111
EMCO LISN (2)	3816/2		1077, 1079
EMCO LISN	3725/2		2009
Microwave Preamp/40dB Gain	HP 83017A (0.5-26.5GHz)		3123A00181
Microwave Cables	MicroCoax (1.0-26.5GHz)		
Ailtech/Eaton Receiver	NM37/57A-SL		0792-03271
Spectrum Analyzer	HP 8591A		3034A01395
Modulation Analyzer	HP 8901A		2432A03467
NTSC Pattern Generator	Leader 408		0377433
Noise Figure Meter	HP 8970B		3106A02189
Noise Figure Meter	Ailtech 7510		TE31700
Noise Generator	Ailtech 7010		1473
Microwave Survey Meter	Holaday Model 1501 (2.450GHz)		80931
Digital Thermometer	Extech Instruments 421305		426966
Attenuator	HP 8495A (0-70dB) DC-4GHz		
Bi-Directional Coax Coupler	Narda 3020A (50-1000MHz)		
Shielded Screen Room	RF Lindgren Model 26-2/2-0		6710 (PCT270)
Shielded Semi-Anechoic Chamber	Ray Proof Model S81		R2437 (PCT278)
Environmental Chamber	Associated Systems Model 1025 (Temperature/Humidity)		PCT285

* Calibration traceable to the National Institute of Standards and Technology (NIST).

Conclusion

The data collected shows that the **Panasonic Cordless Telephone System** complies with Part 15C of the FCC Rules.

Appendix A: FCC ID Sample Label & Location

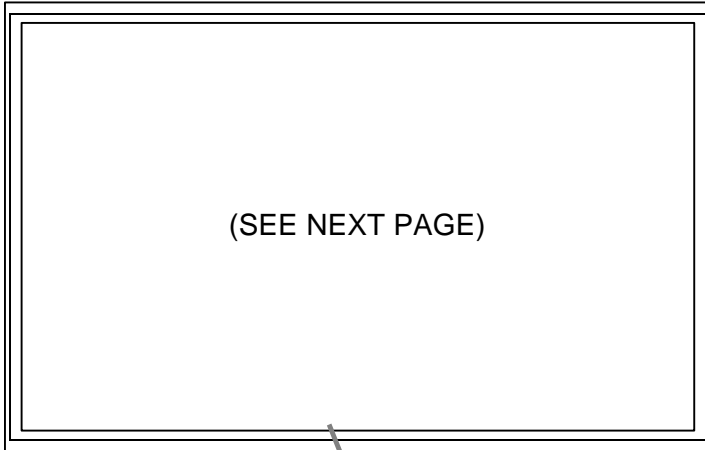

LABELLING REQUIREMENTS PER §§ 2.925 & §§ 15.19

The Label shown shall be permanently affixed at a conspicuous location on the device and be readily visible to the user at the time of purchase.

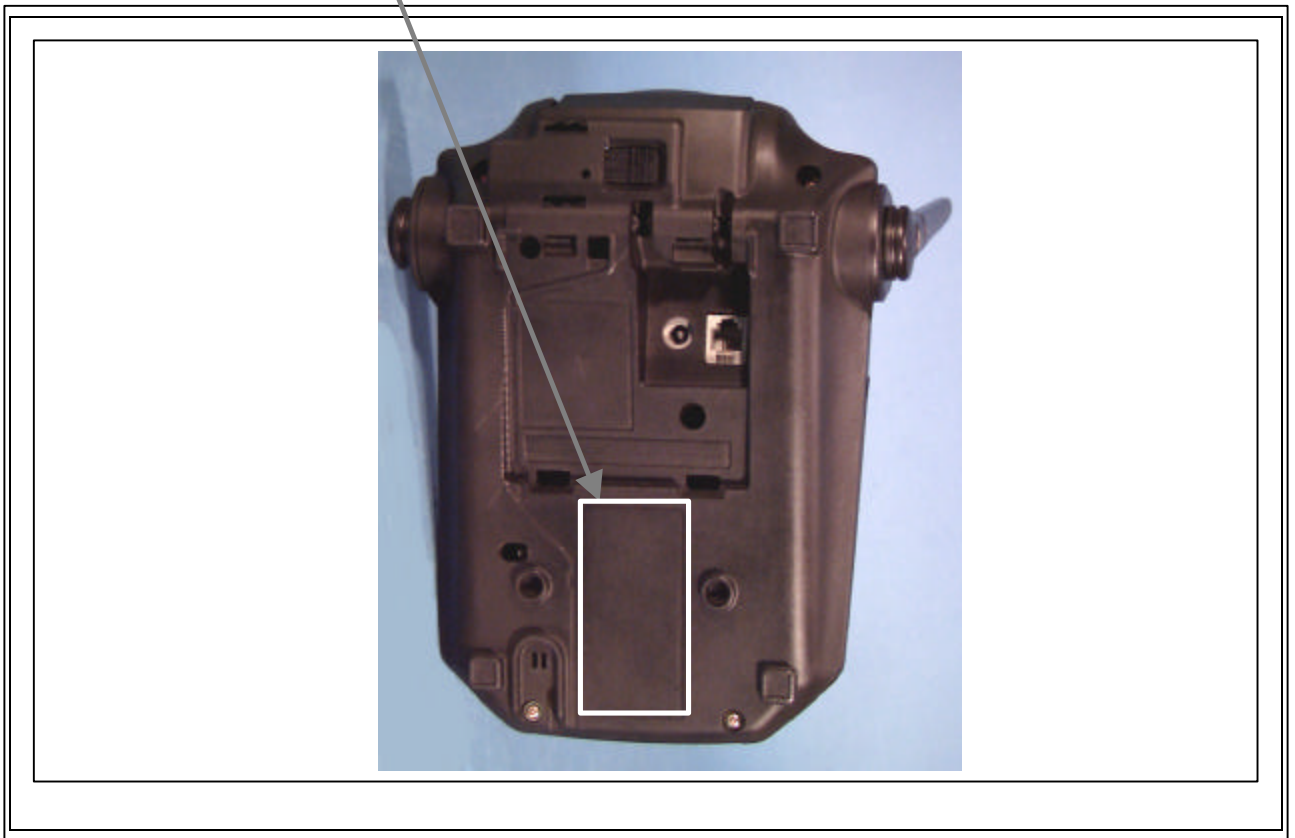

FCC ID: ACJ96NKX-TG2583

THIS DEVICE COMPLIES WITH PART 15 OF FCC RULES. OPERATION IS SUBJECT TO THE FOLLOWING TWO CONDITIONS: 1. THIS DEVICE MAY NOT CAUSE HARMFUL INTERFERENCE, AND 2. THIS DEVICE MUST ACCEPT ANY INTERFERENCE RECEIVED, INCLUDING INTERFERENCE THAT MAY CAUSE UNDESIRE OPERATION.

Appendix B – Plots of Emissions

PANASONIC FCC ID: RCJ96NKX-TG2583
DSS Cordless Phone LINE A

PCTEST Engineering Lab.

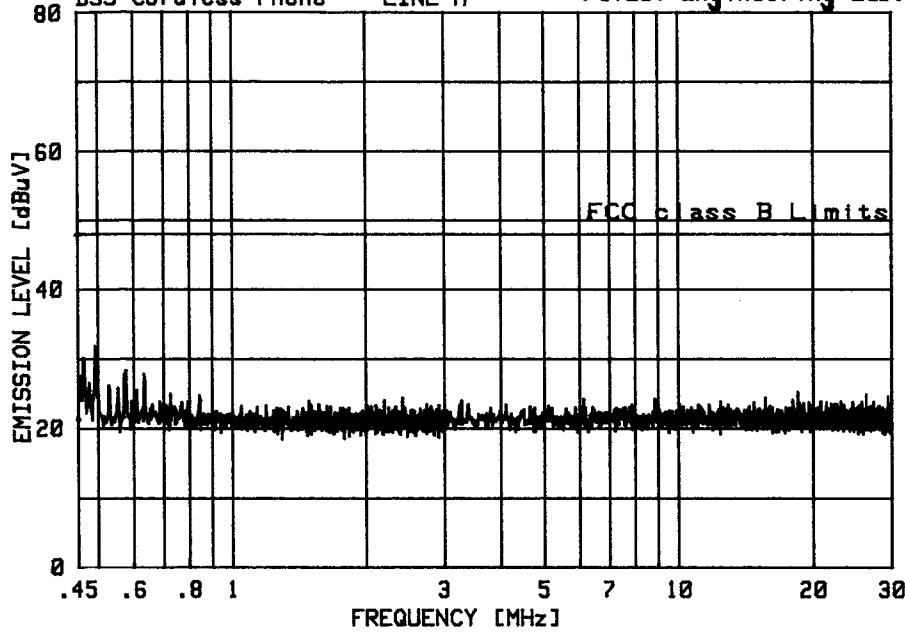

No.	Freq. [MHz]	Quasi-Pk [dBuV]	Average [dBuV]	QP-RV [dB]	Emission [dBuV]	Limit [dBuV]	Margin [dB]
1	.471	23.02	-	-	23.02	48.00	-24.98
2	.454	23.19	-	-	23.19	48.00	-24.81
3	.548	22.36	-	-	22.36	48.00	-25.64
4	.604	22.25	-	-	22.25	48.00	-25.75
5	.516	23.11	-	-	23.11	48.00	-24.89
6	.528	22.49	-	-	22.49	48.00	-25.51
7	.581	22.35	-	-	22.35	48.00	-25.65
8	18.432	23.26	-	-	23.26	48.00	-24.74
9	.698	21.97	-	-	21.97	48.00	-26.03
10	26.214	21.68	-	-	21.68	48.00	-26.32

PANASONIC FCC ID: RCJ96NKX-TG2583
DSS Cordless Phone LINE B

PCTEST Engineering Lab.

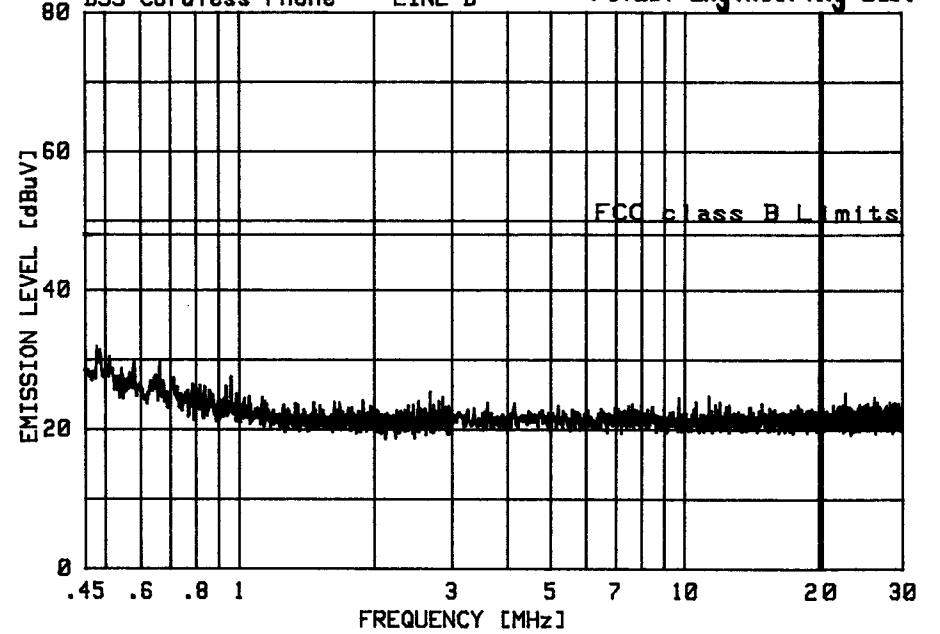

No.	Freq. [MHz]	Quasi-Pk [dBuV]	Average [dBuV]	QP-RV [dB]	Emission [dBuV]	Limit [dBuV]	Margin [dB]
1	.452	27.46	-	-	27.46	48.00	-20.54
2	.638	24.51	-	-	24.51	48.00	-23.49
3	.551	25.17	-	-	25.17	48.00	-22.83
4	.543	26.25	-	-	26.25	48.00	-21.75
5	.930	22.44	-	-	22.44	48.00	-25.56
6	.683	24.08	-	-	24.08	48.00	-23.92
7	.757	24.01	-	-	24.01	48.00	-23.99
8	.905	22.87	-	-	22.87	48.00	-25.13
9	.808	23.29	-	-	23.29	48.00	-24.71
10	.828	23.32	-	-	23.32	48.00	-24.68

* Agilent 11:00:47 Nov 16, 2000

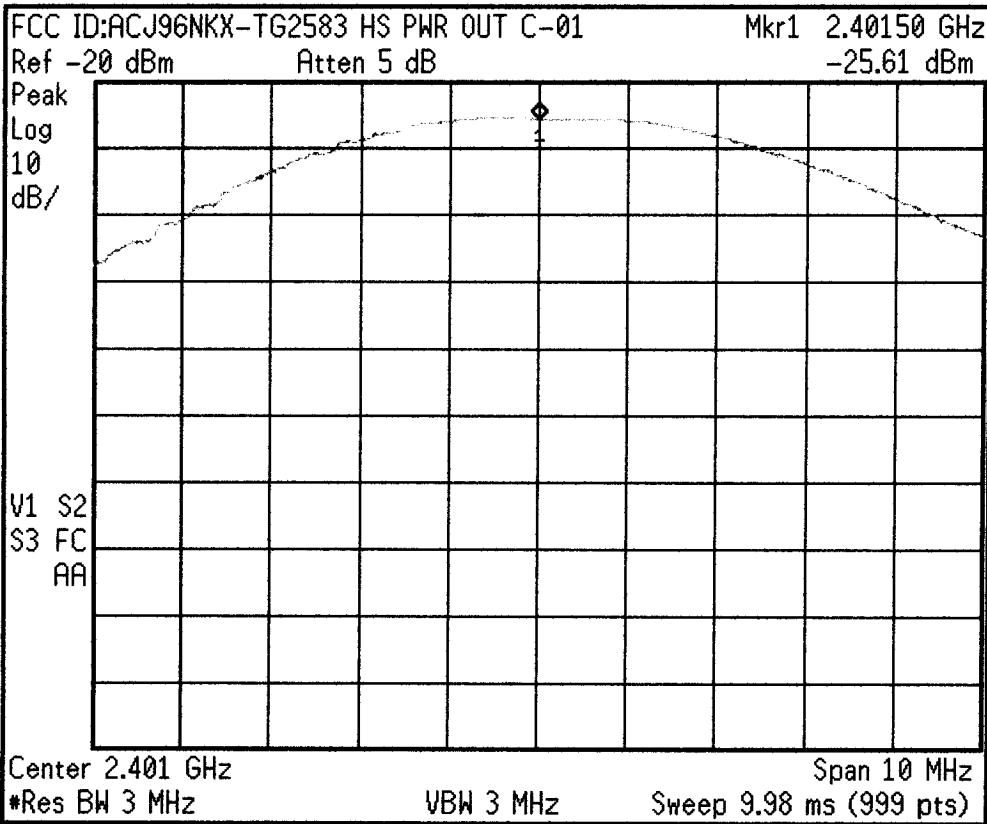

Trace
Trace 1 2 3
Clear Write
Max Hold
Min Hold
View
Blank
More 1 of 2

* Agilent 11:05:13 Nov 16, 2000

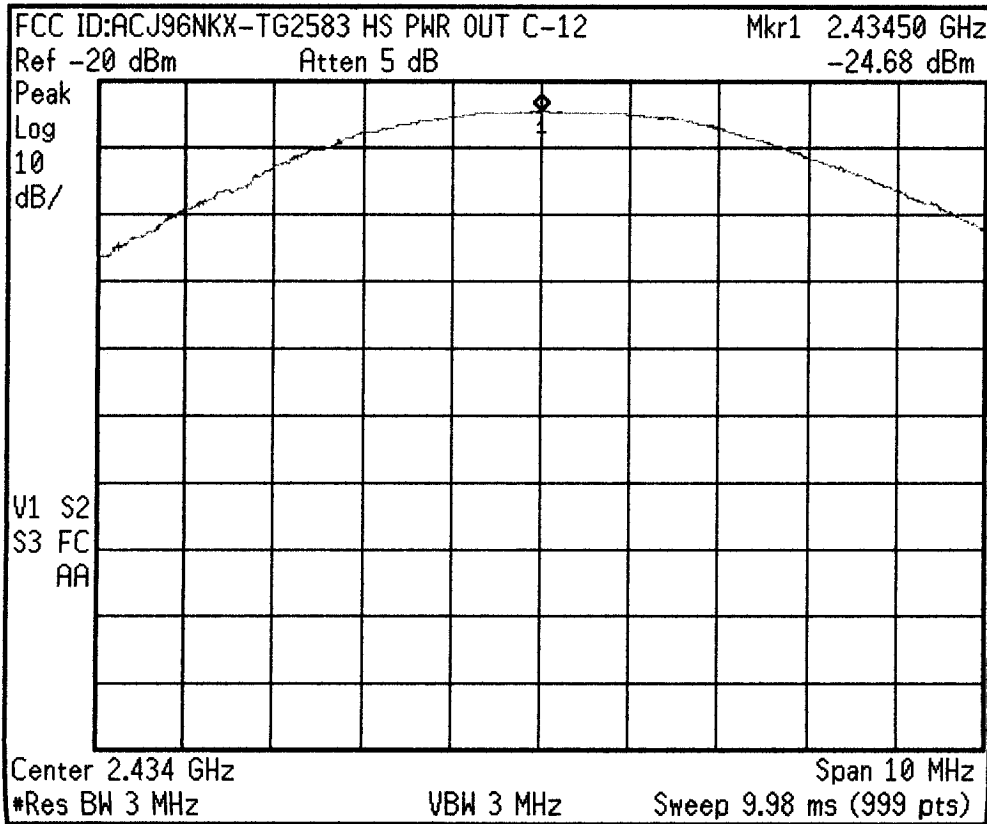

Freq/Channel
Center Freq 2.43450000 GHz
Start Freq 2.42950000 GHz
Stop Freq 2.43950000 GHz
CF Step 1.00000000 MHz Auto Man
Freq Offset 0.00000000 Hz
Signal Track On Off

* Agilent 11:06:04 Nov 16, 2000

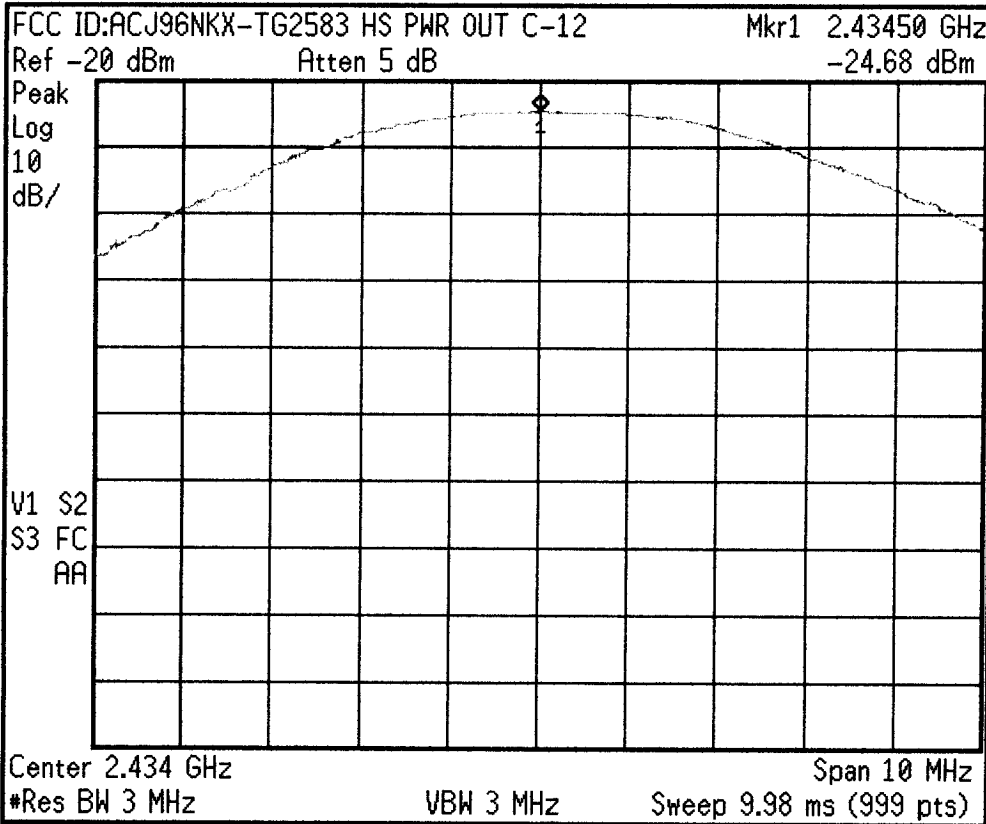

Freq/Channel

Center Freq
2.43450000 GHz

Start Freq
2.42950000 GHz

Stop Freq
2.43950000 GHz

CF Step
1.00000000 MHz
Auto Man

Freq Offset
0.00000000 Hz

Signal Track
On Off

* Agilent 11:09:26 Nov 16, 2000

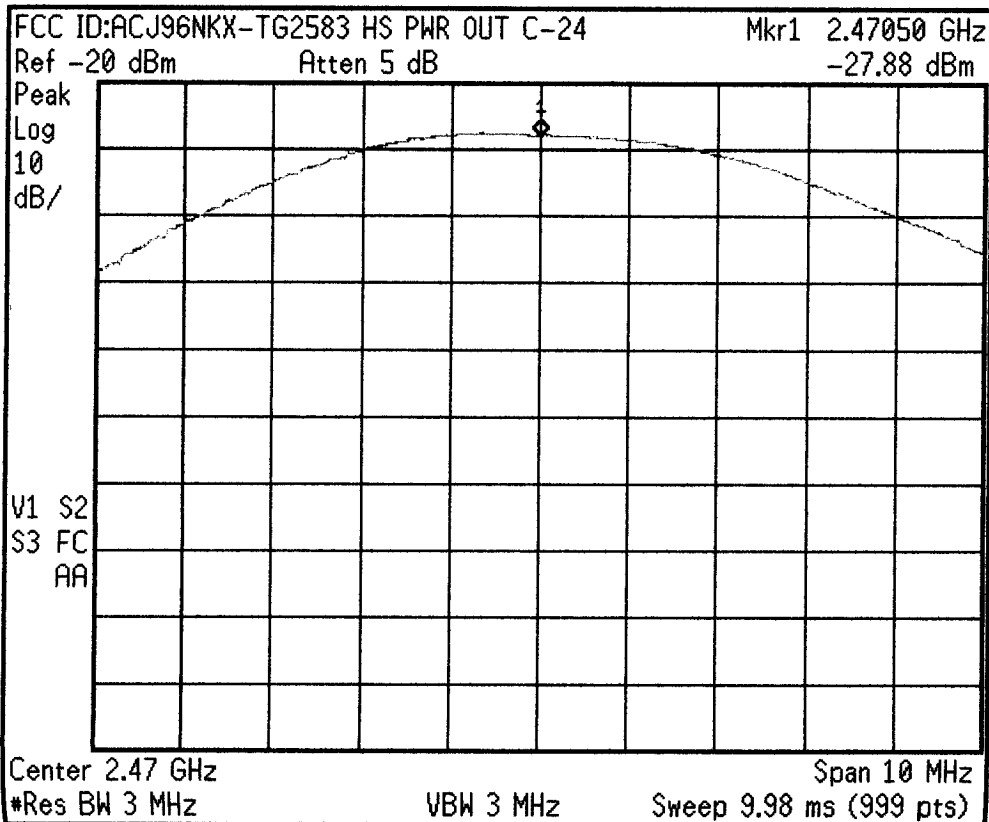

Freq/Channel

Center Freq
2.47050000 GHz

Start Freq
2.46550000 GHz

Stop Freq
2.47550000 GHz

CF Step
1.00000000 MHz
Auto Man

Freq Offset
0.00000000 Hz

Signal Track
On Off

* Agilent 16:57:51 Nov 16, 2000

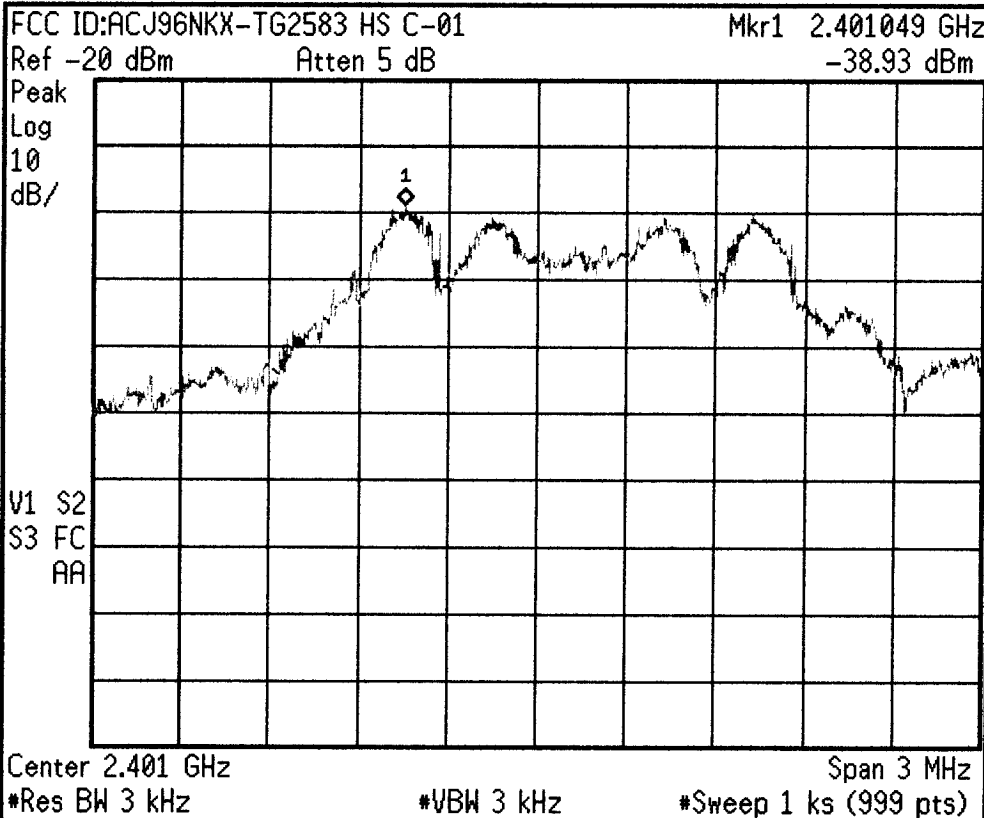

Freq/Channel

Center Freq
2.40150000 GHz

Start Freq
2.40000000 GHz

Stop Freq
2.40300000 GHz

CF Step
300.000000 kHz
Auto Man

Freq Offset
0.00000000 Hz

Signal Track
On Off

* Agilent 17:16:18 Nov 16, 2000

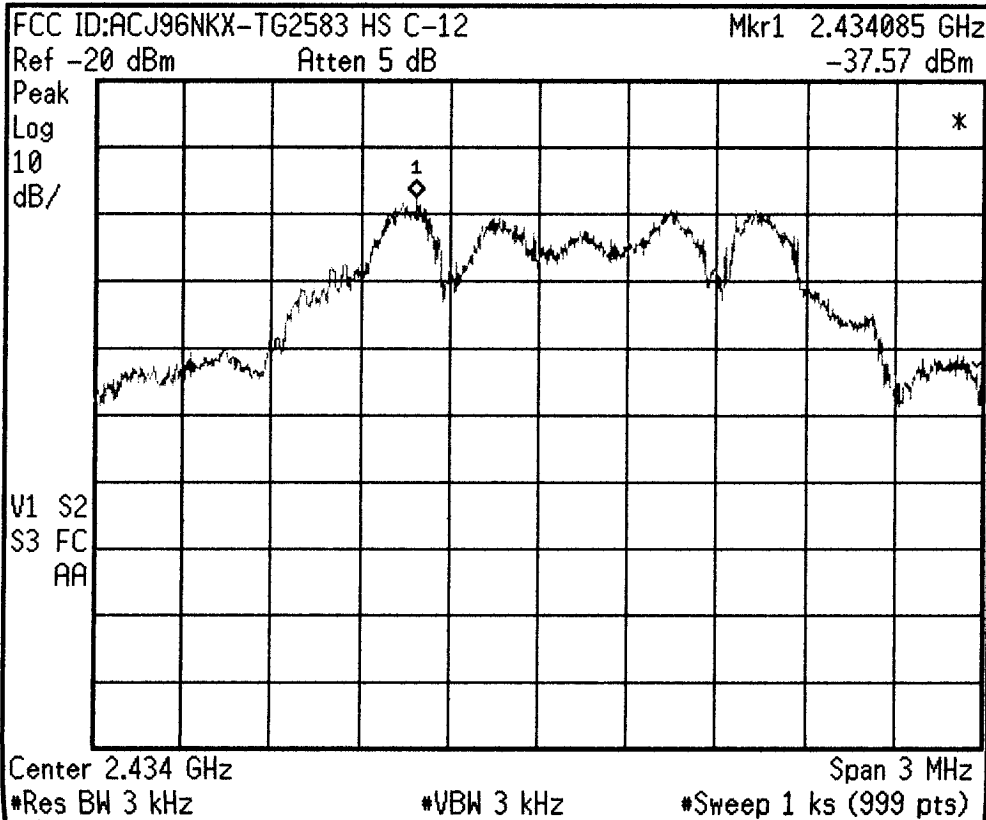

Freq/Channel

Center Freq
2.43450000 GHz

Start Freq
2.43300000 GHz

Stop Freq
2.43600000 GHz

CF Step
300.000000 kHz
Auto Man

Freq Offset
0.00000000 Hz

Signal Track
On Off

* Agilent 17:17:14 Nov 16, 2000

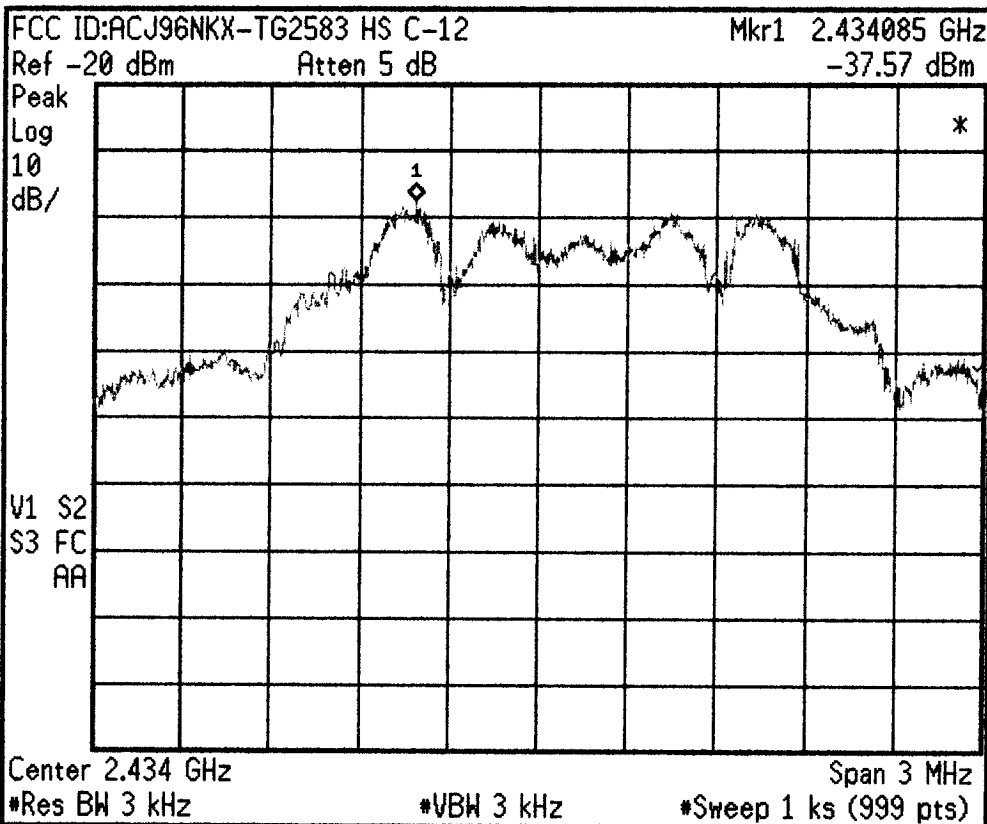

Freq/Channel
Center Freq 2.43450000 GHz
Start Freq 2.43300000 GHz
Stop Freq 2.43600000 GHz
CF Step 300.000000 kHz Auto Man
Freq Offset 0.00000000 Hz
Signal Track On Off

* Agilent 17:35:05 Nov 16, 2000

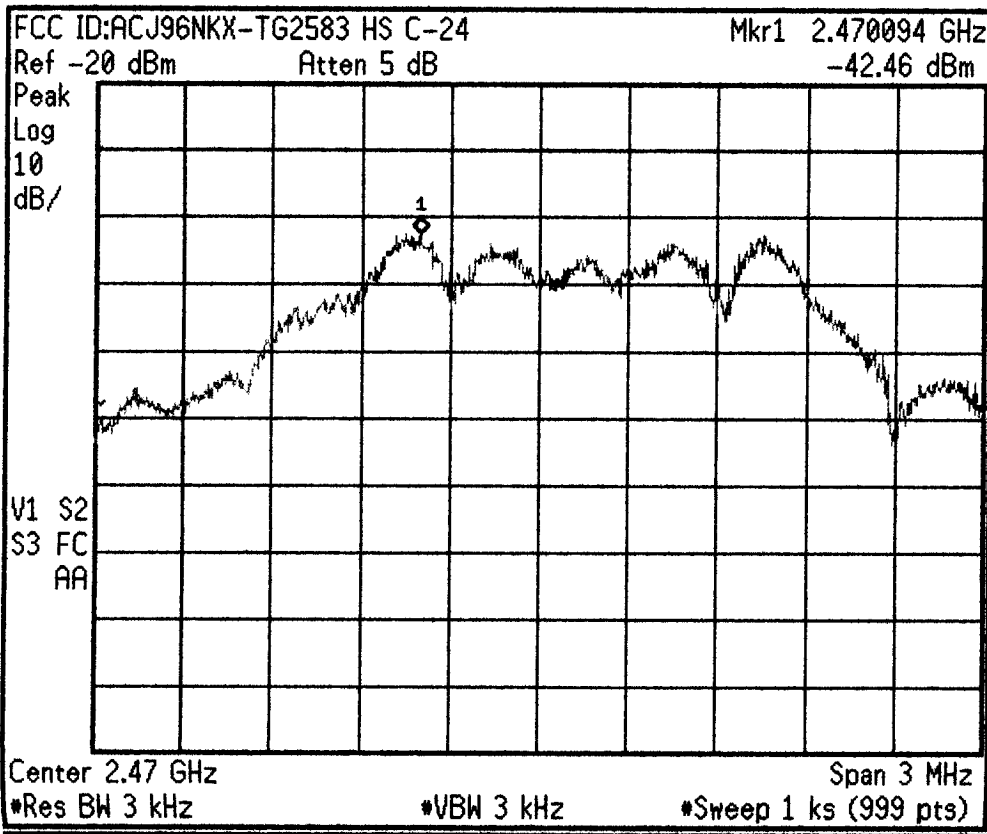

Freq/Channel
Center Freq 2.47050000 GHz
Start Freq 2.46900000 GHz
Stop Freq 2.47200000 GHz
CF Step 300.000000 kHz Auto Man
Freq Offset 0.00000000 Hz
Signal Track On Off

* Agilent 12:27:08 Nov 16, 2000

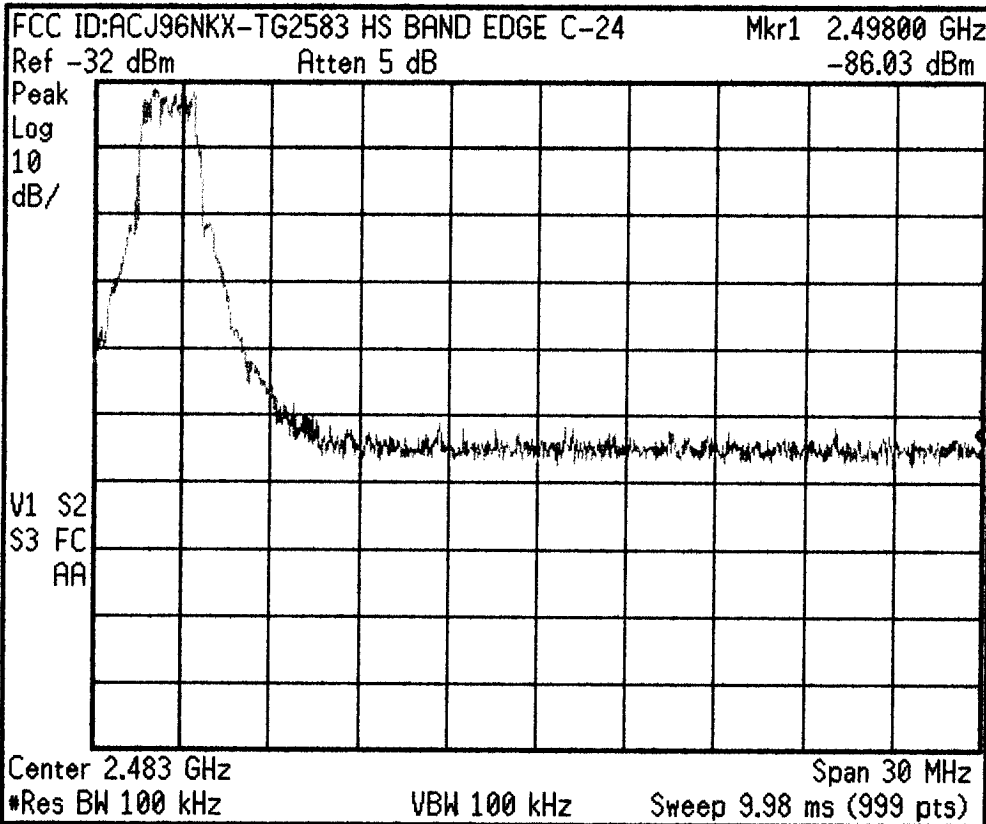

Marker

Select Marker
 1 2 3 4

Normal

Delta

Band Pair
 Start Stop

Span Pair
 Span Center

Off

More
 1 of 2

* Agilent 12:41:41 Nov 16, 2000

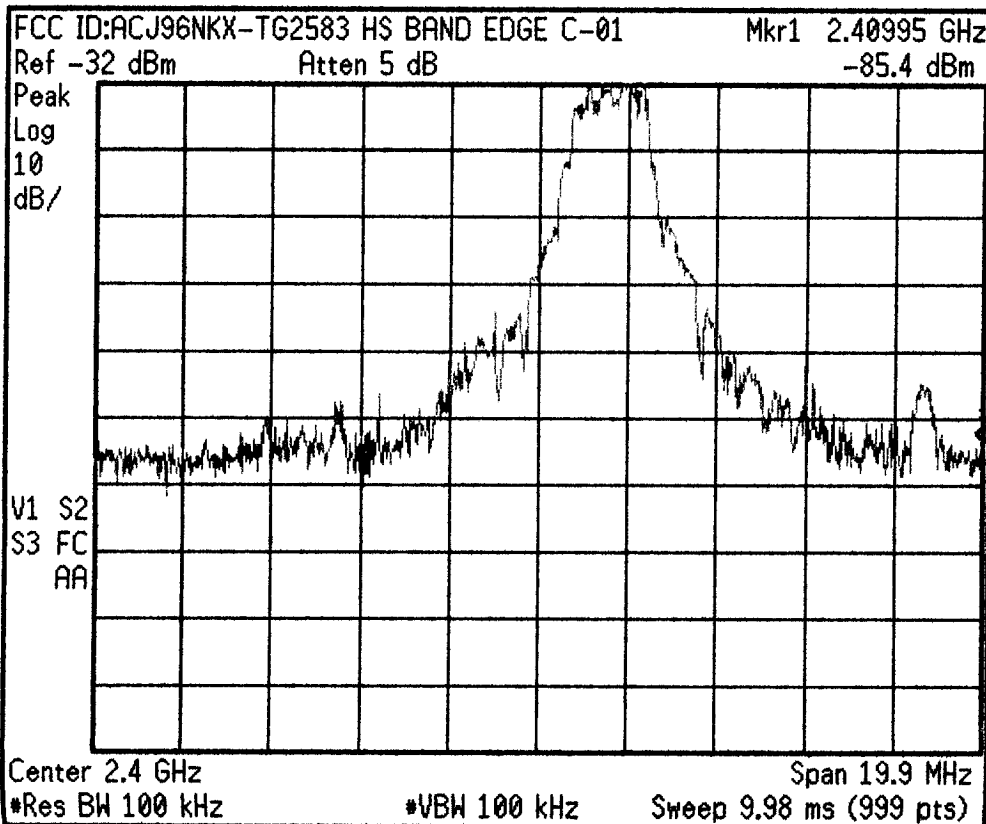

Freq/Channel

Center Freq
 2.40000000 GHz

Start Freq
 2.39005025 GHz

Stop Freq
 2.40994975 GHz

CF Step
 1.98995000 MHz
 Auto Man

Freq Offset
 0.00000000 Hz

Signal Track
 On Off

* Agilent 12:55:36 Nov 16, 2000

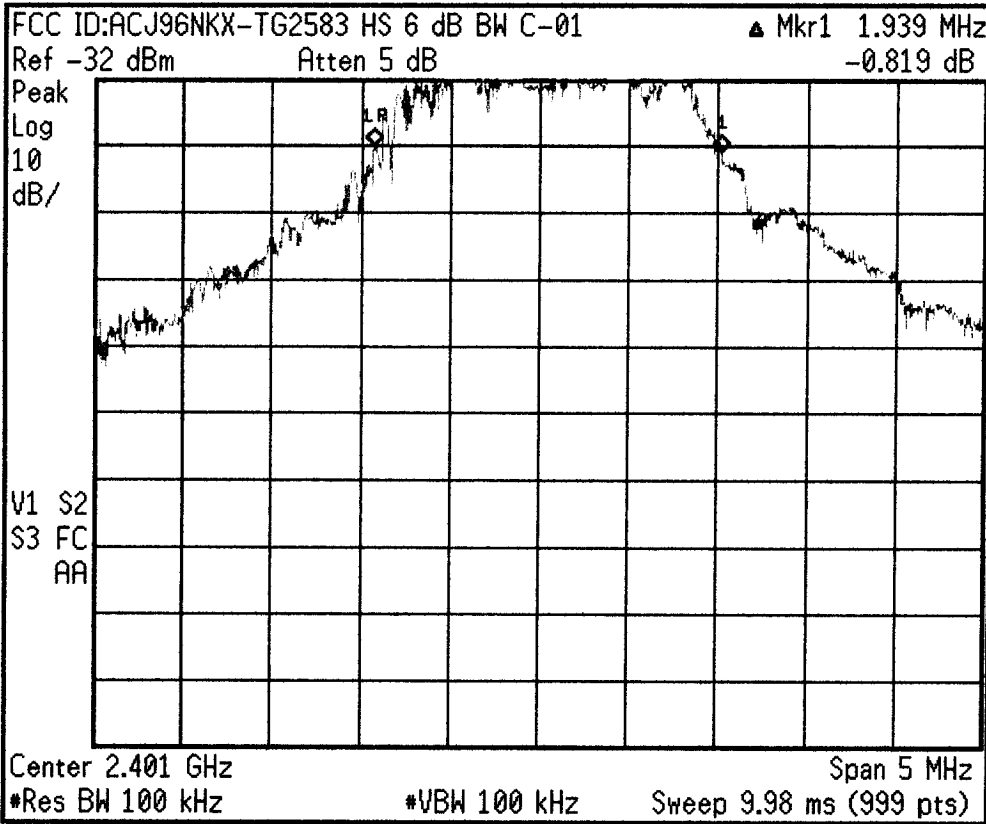

Marker
Select Marker 1 2 3 4
Normal
Delta
Band Pair Start Stop
Span Pair Span Center
Off
More 1 of 2

* Agilent 13:06:07 Nov 16, 2000

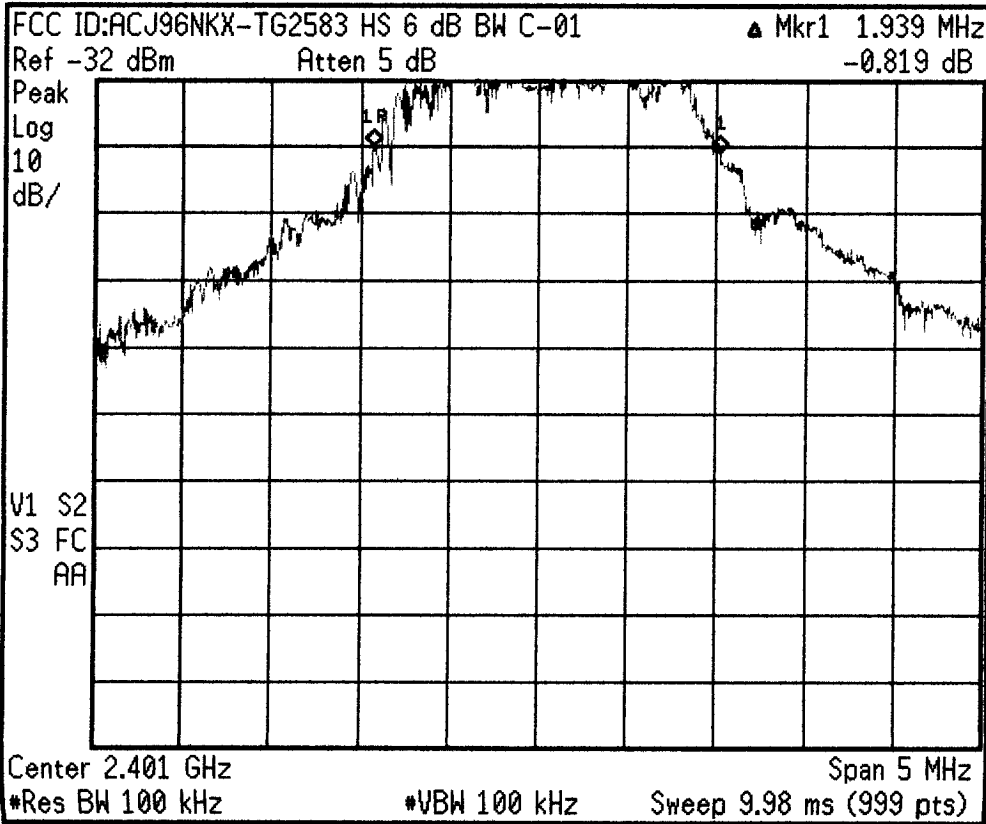

Marker
Select Marker 1 2 3 4
Normal
Delta
Band Pair Start Stop
Span Pair Span Center
Off
More 1 of 2

* Agilent 12:20:03 Nov 16, 2000

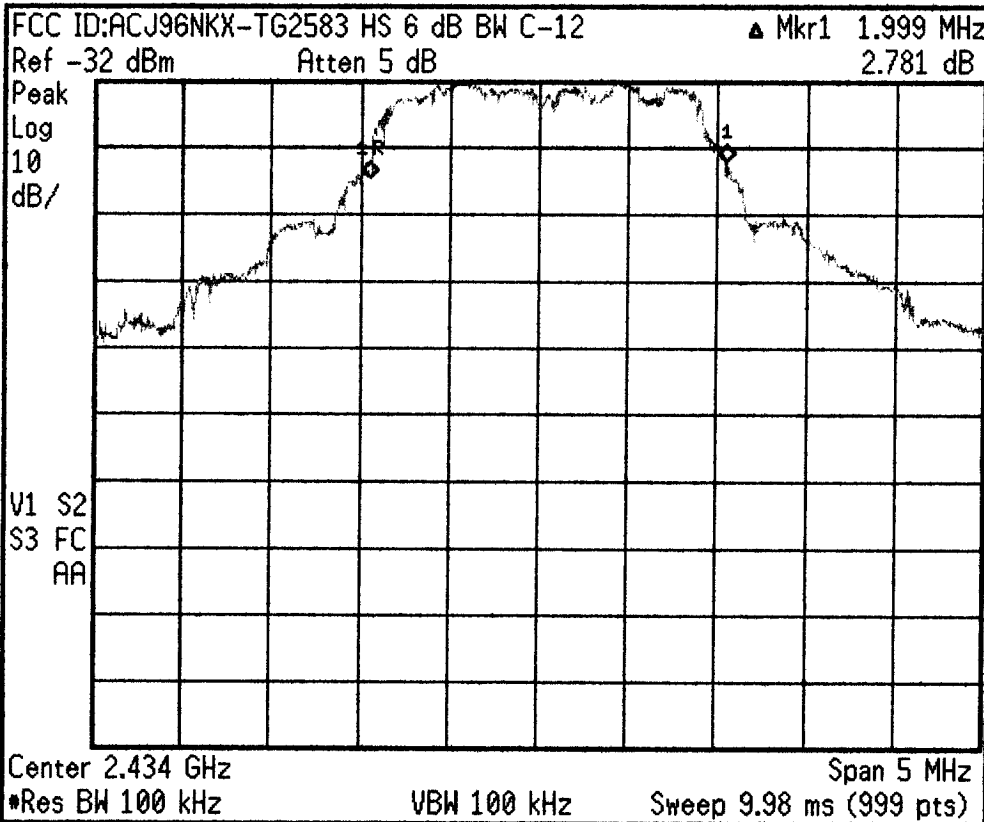

Freq/Channel

Center Freq
2.43450000 GHz

Start Freq
2.43200000 GHz

Stop Freq
2.43700000 GHz

CF Step
500.000000 kHz
Auto Man

Freq Offset
0.00000000 Hz

Signal Track
On Off

* Agilent 12:24:21 Nov 16, 2000

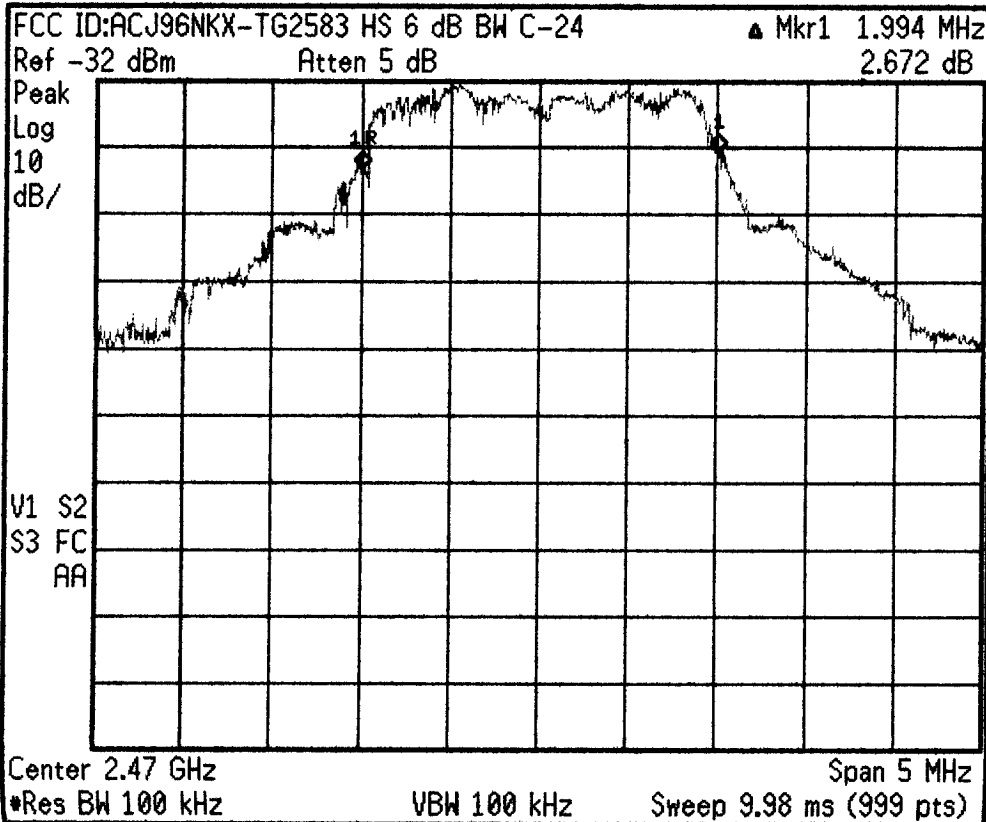

Freq/Channel

Center Freq
2.47050000 GHz

Start Freq
2.46800000 GHz

Stop Freq
2.47300000 GHz

CF Step
500.000000 kHz
Auto Man

Freq Offset
0.00000000 Hz

Signal Track
On Off

* Agilent 14:24:41 Nov 16, 2000

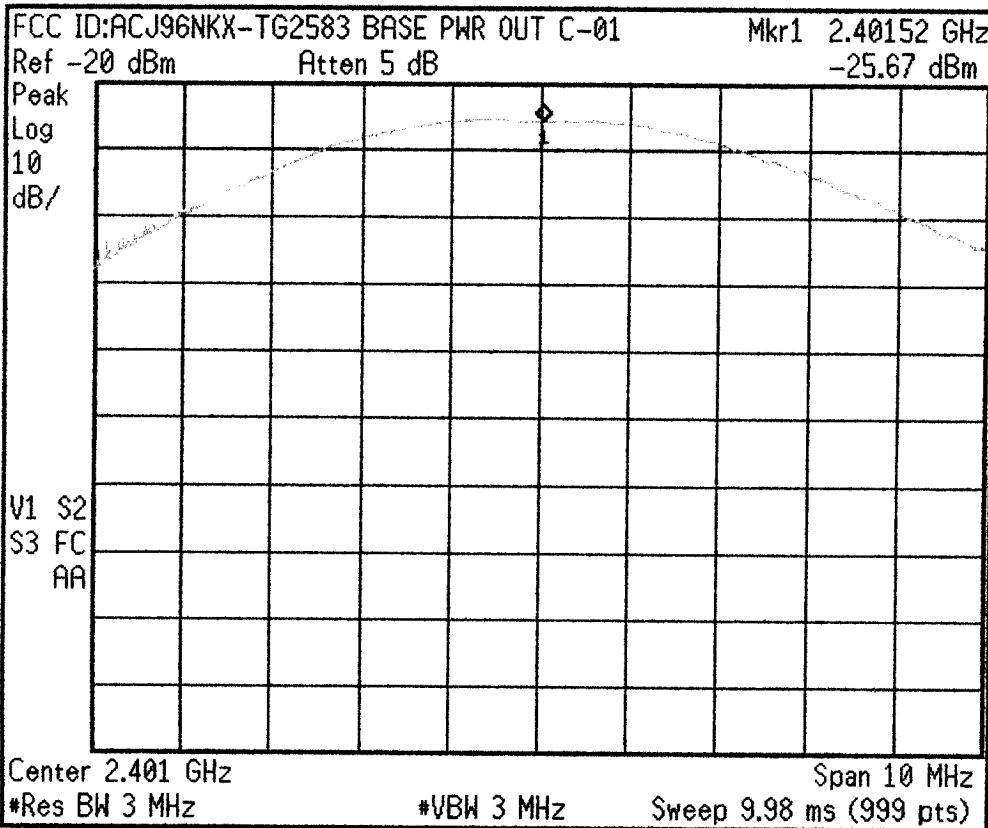

Freq/Channel
Center Freq 2.40150000 GHz
Start Freq 2.39650000 GHz
Stop Freq 2.40650000 GHz
CF Step 1.00000000 MHz Auto Man
Freq Offset 0.00000000 Hz
Signal Track On Off

* Agilent 14:26:34 Nov 16, 2000

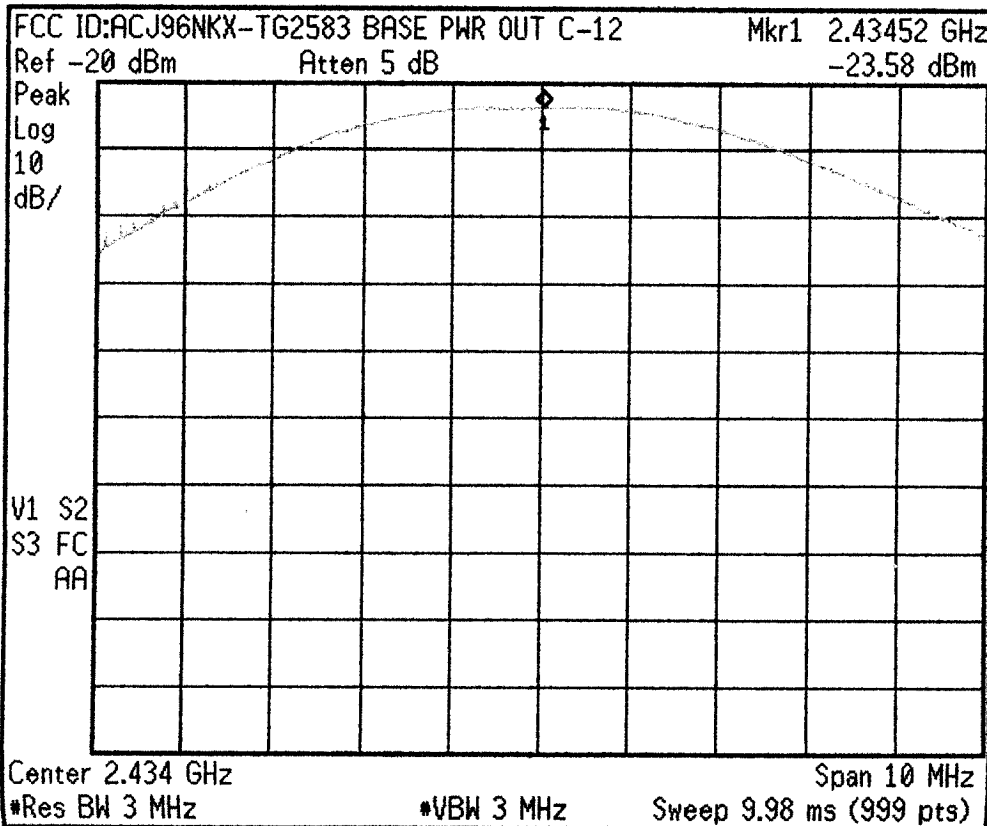

Freq/Channel
Center Freq 2.43450000 GHz
Start Freq 2.42950000 GHz
Stop Freq 2.43950000 GHz
CF Step 1.00000000 MHz Auto Man
Freq Offset 0.00000000 Hz
Signal Track On Off

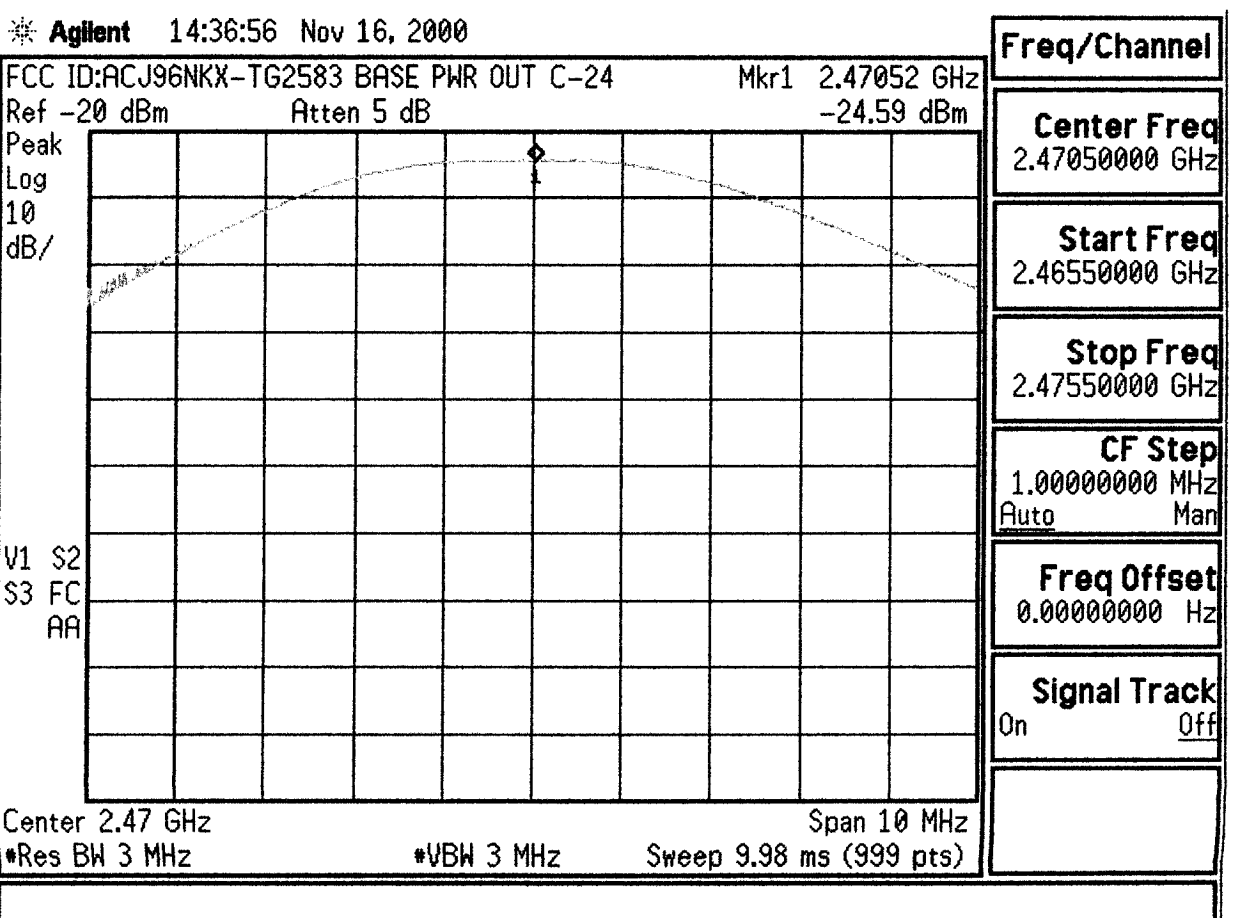
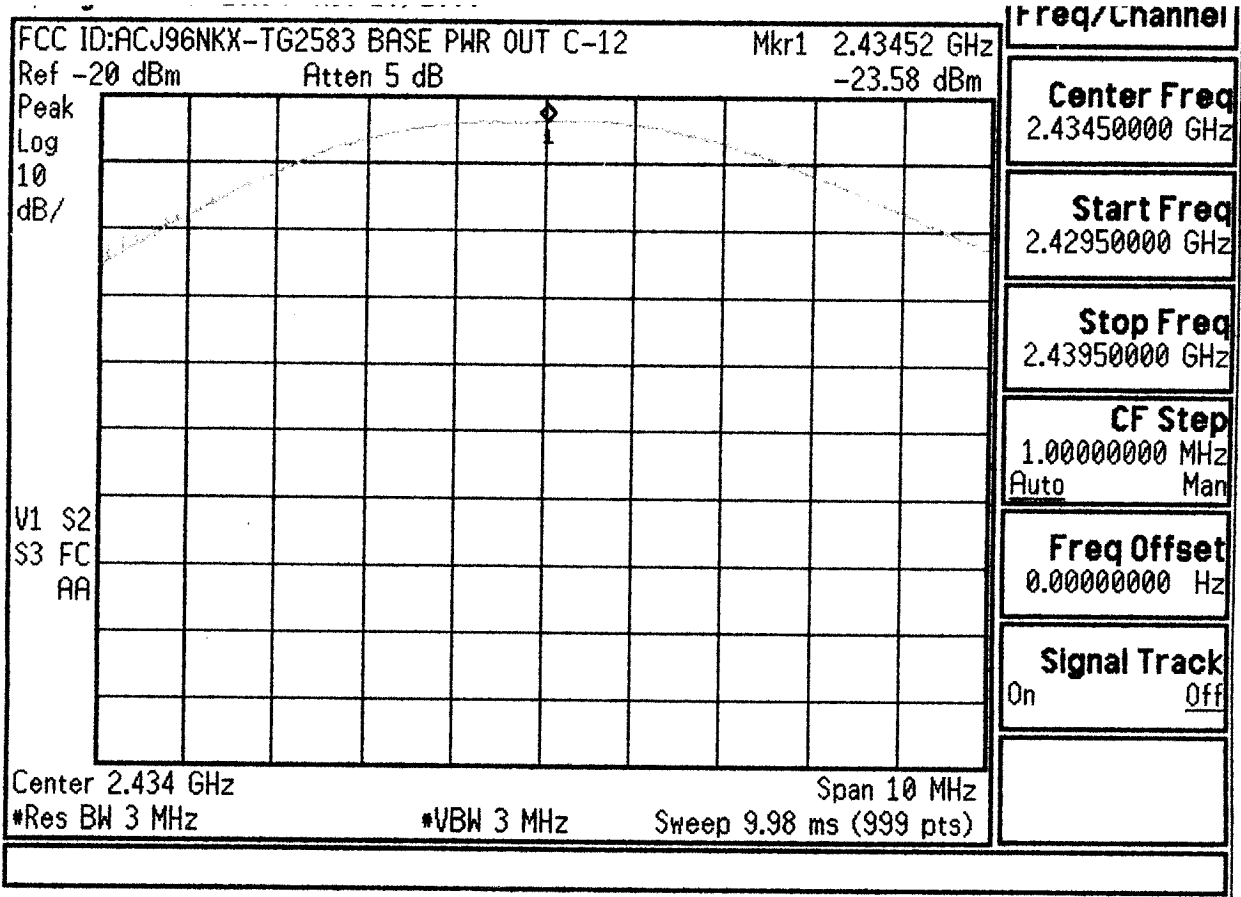

* Agilent 17:32:12 Nov 17, 2000

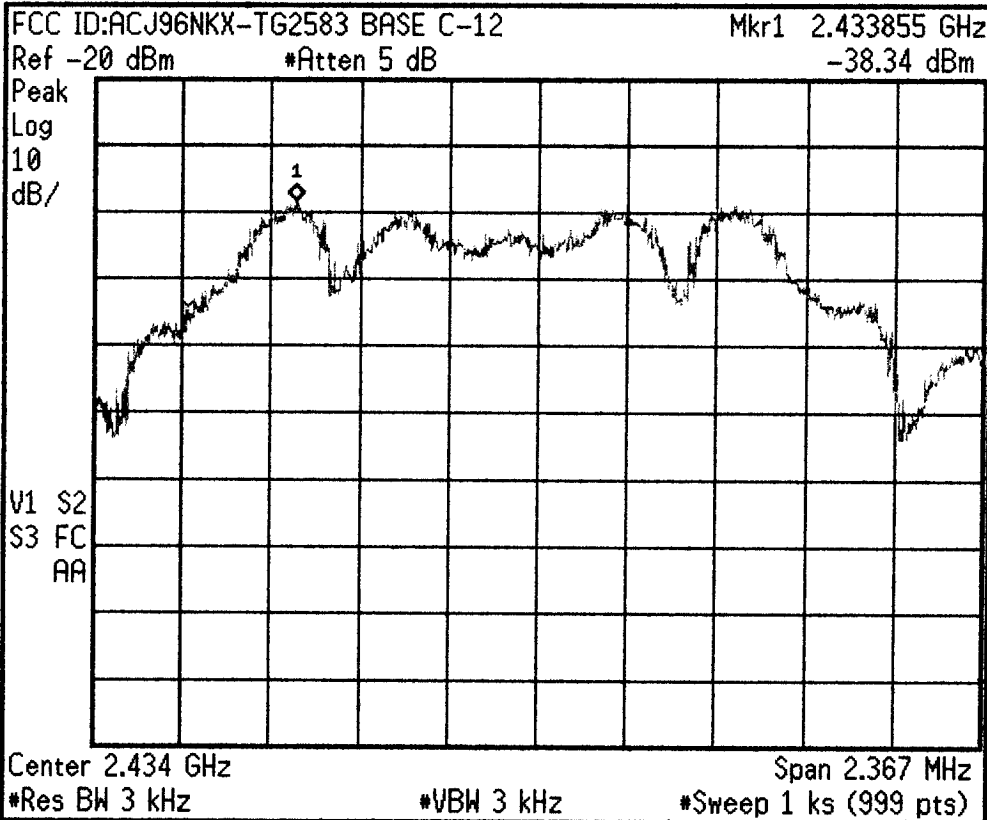

Freq/Channel

Center Freq
2.43450000 GHz

Start Freq
2.43331650 GHz

Stop Freq
2.43568350 GHz

CF Step
2.47050000 GHz
Auto Man

Freq Offset
0.00000000 Hz

Signal Track
On Off

* Agilent 17:35:18 Nov 17, 2000

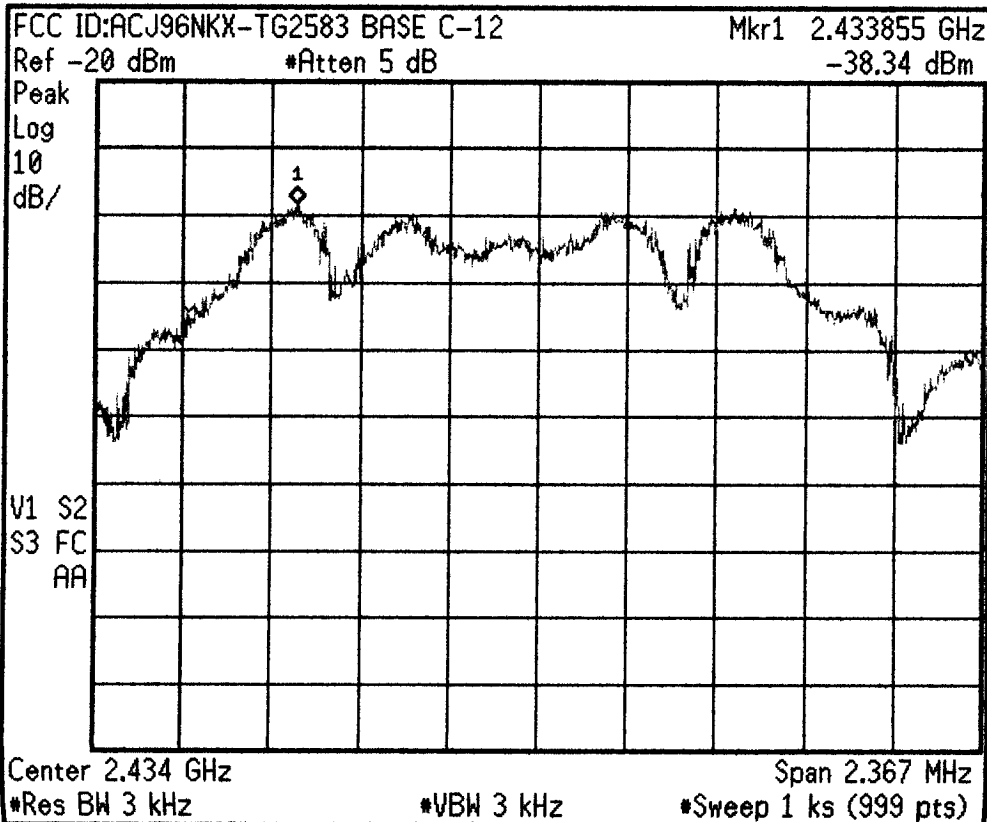

Freq/Channel

Center Freq
2.43450000 GHz

Start Freq
2.43331650 GHz

Stop Freq
2.43568350 GHz

CF Step
2.47050000 GHz
Auto Man

Freq Offset
0.00000000 Hz

Signal Track
On Off

Agilent 15:18:15 Nov 16, 2000

FCC ID:ACJ96NKX-TG2583 BASE C-24

Mkr1 2.469857 GHz

Ref -20 dBm

Atten 5 dB

-37.9 dBm

Peak
Log
10
dB/

W1 S2
S3 FC
AA

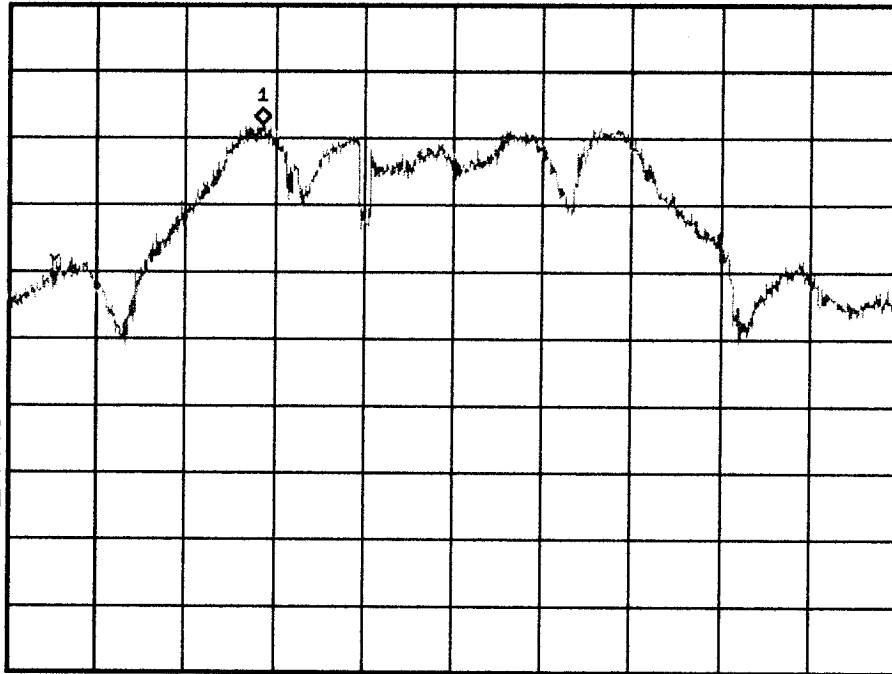

Center 2.47 GHz

Span 3 MHz

*Res BW 3 kHz

*VBW 3 kHz

*Sweep 1 ks (999 pts)

Freq/Channel

Center Freq
2.47050000 GHz

Start Freq
2.46900000 GHz

Stop Freq
2.47200000 GHz

CF Step
300.000000 kHz
Auto Man

Freq Offset
0.00000000 Hz

Signal Track
On Off

Agilent 15:41:30 Nov 16, 2000

FCC ID:ACJ96NKX-TG2583 BASE C-01

Mkr1 2.400857 GHz

Ref -20 dBm

Atten 5 dB

-39.46 dBm

Peak
Log
10
dB/

W1 S2
S3 FC
AA

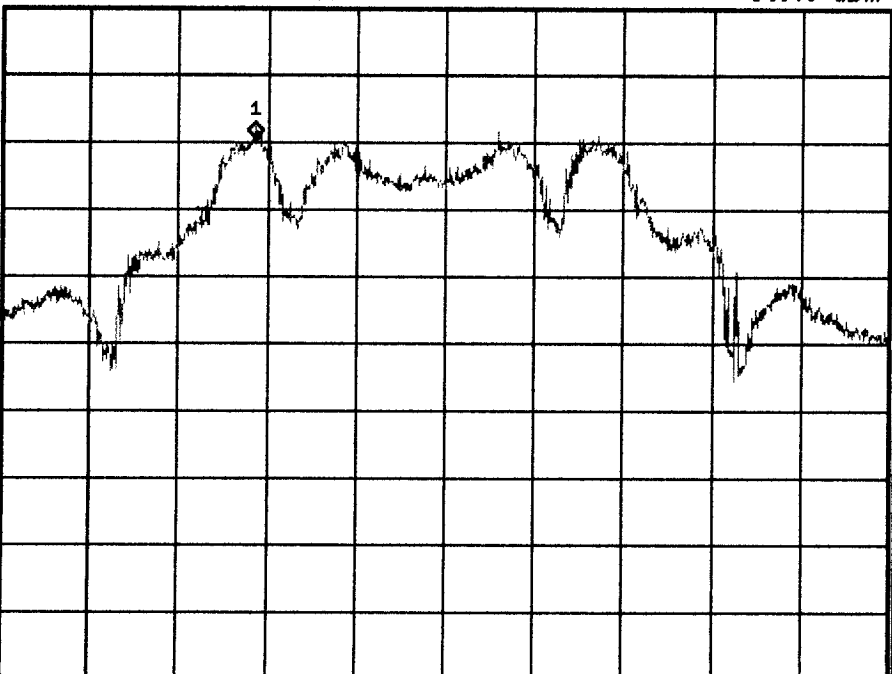

Center 2.401 GHz

Span 3 MHz

*Res BW 3 kHz

*VBW 3 kHz

*Sweep 1 ks (999 pts)

Trace

Trace
1 2 3

Clear Write

Max Hold

Min Hold

View

Blank

More
1 of 2

* Agilent 16:12:45 Nov 16, 2000

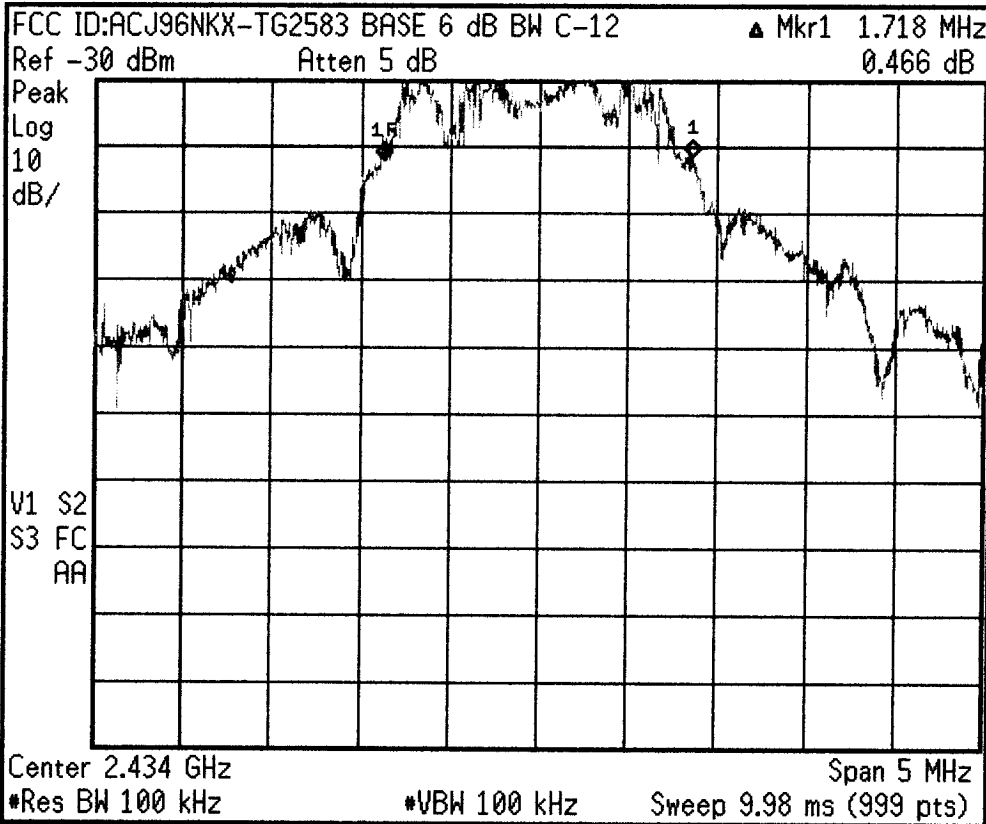

Freq/Channel

Center Freq
2.43450000 GHz

Start Freq
2.43200000 GHz

Stop Freq
2.43700000 GHz

CF Step
500.000000 kHz
Auto Man

Freq Offset
0.00000000 Hz

Signal Track
On Off

* Agilent 16:21:06 Nov 16, 2000

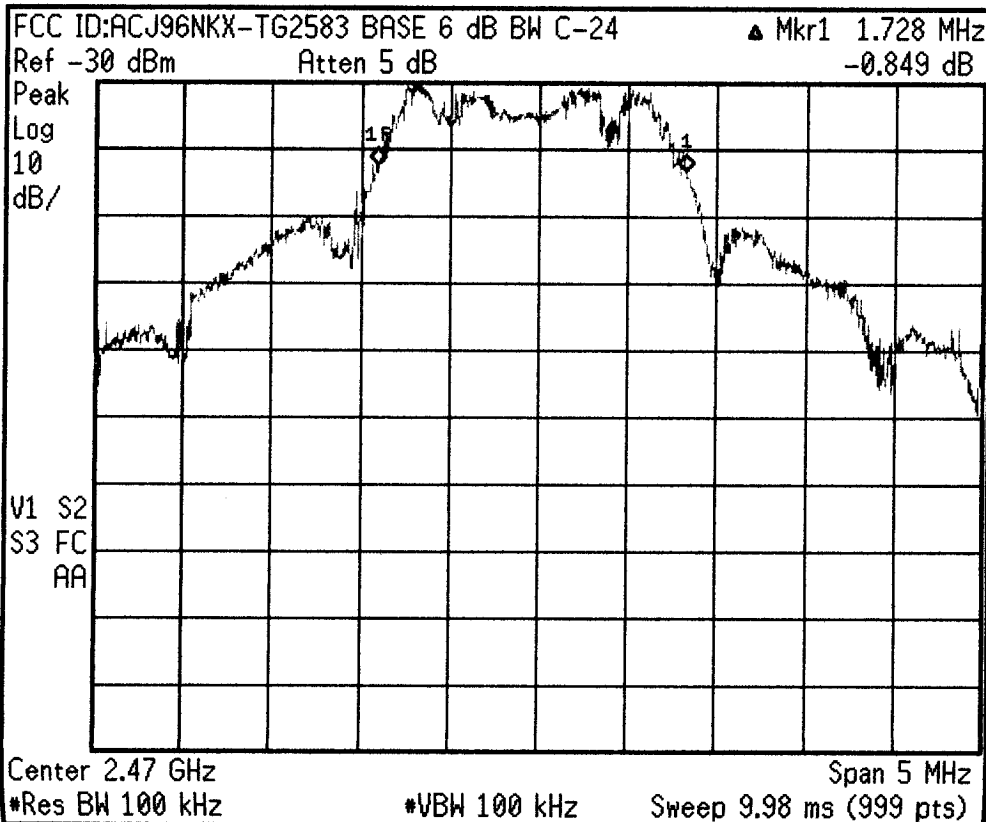

Freq/Channel

Center Freq
2.47050000 GHz

Start Freq
2.46800000 GHz

Stop Freq
2.47300000 GHz

CF Step
500.000000 kHz
Auto Man

Freq Offset
0.00000000 Hz

Signal Track
On Off

* Agilent 16:21:44 Nov 16, 2000

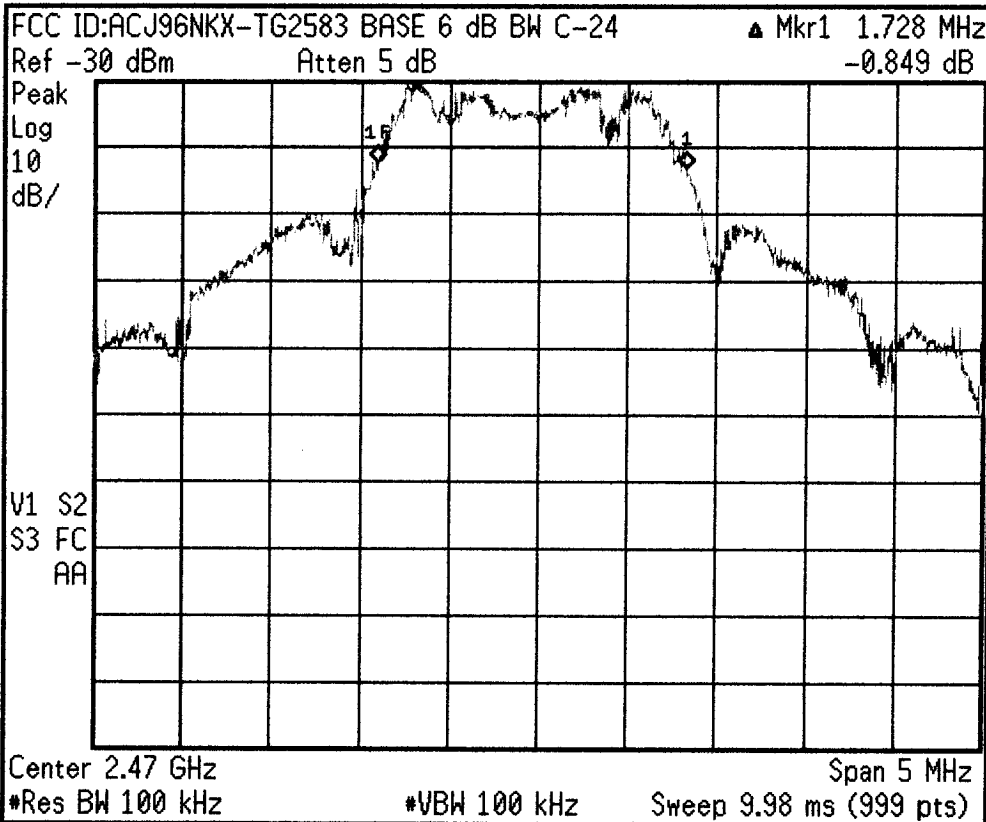

Freq/Channel

Center Freq
2.47050000 GHz

Start Freq
2.46800000 GHz

Stop Freq
2.47300000 GHz

CF Step
500.000000 kHz
Auto Man

Freq Offset
0.00000000 Hz

Signal Track
On Off

* Agilent 16:24:08 Nov 16, 2000

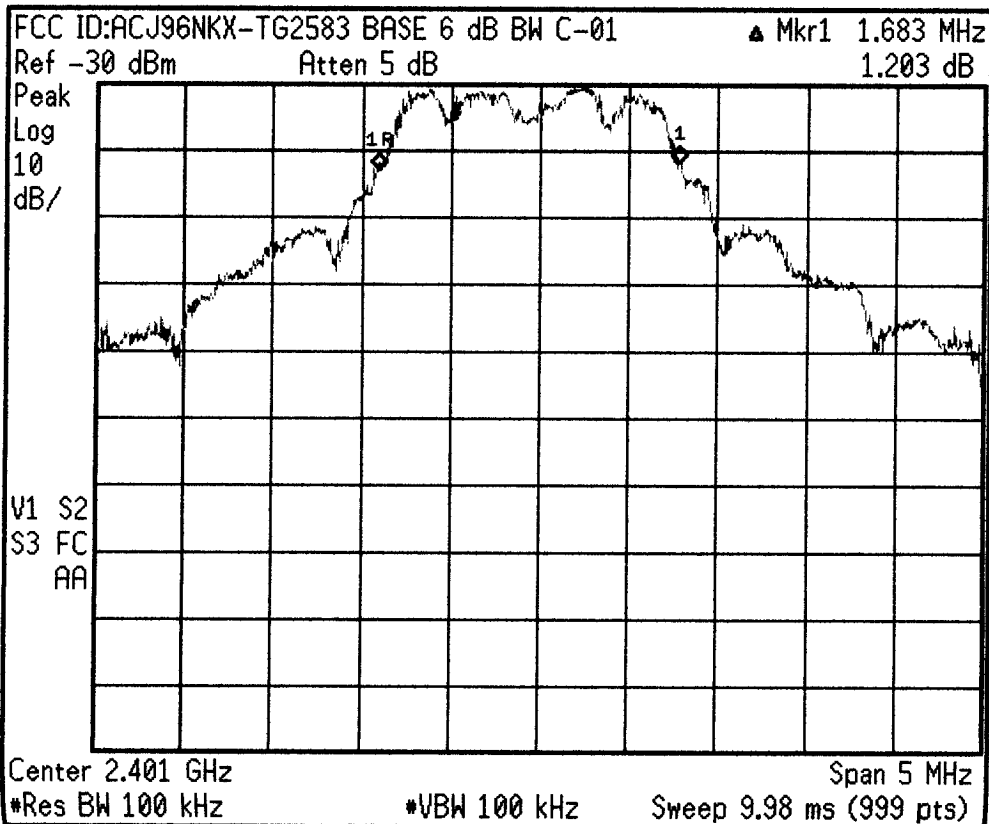

Freq/Channel

Center Freq
2.40150000 GHz

Start Freq
2.39900000 GHz

Stop Freq
2.40400000 GHz

CF Step
500.000000 kHz
Auto Man

Freq Offset
0.00000000 Hz

Signal Track
On Off

