

EMC EMISSION - **TEST REPORT**

JQA APPLICATION No. : KL80010447

Name of Product : 2.4GHz Digital Cordless Telephone(Handset)

Model/Type No. : KX-TG2257

FCC ID : ACJ96NKX-TG2257

Applicant : Kyushu Matsushita Electric Co., Ltd.

Address : 1-62, 4-chome, Minoshima, Hakata-ku, Fukuoka 812-8531, Japan

Manufacturer : Kyushu Matsushita Electric Co., Ltd.

Address : 1-62, 4-chome, Minoshima, Hakata-ku, Fukuoka 812-8531, Japan

Receive date of EUT : November 21, 2001

Final Judgement : Passed

TEST RESULTS IN THIS REPORT are obtained in use of equipment that is traceable to National Institute of Advanced Industrial Science and Technology(AIST) under METI Japan and Communications Research Lab.(CRL) under MPHPT Japan.

THE TEST RESULTS only responds to the test sample. This test report shall not be reproduced except in full.

JAPAN QUALITY ASSURANCE ORGANIZATION (JQA)
KITA-KANSAI TESTING CENTER
EMC DIVISION

DIRECTORY

	Page
A) Documentation	
Directory	<u>2</u>
Test Regulation / General Information	<u>3 - 5</u>
Test Conditions	<u>6 - 12</u>
Configuration of EUT / Operation mode of the EUT	<u>13 - 14</u>
EUT Modification / Responsible Party / Deviation from Standard	<u>15</u>
Test results / Measurement Uncertainty	<u>16 - 18</u>
Summary	<u>19</u>
Test System-Arrangement (Drawings)	<u>20</u>
Preliminary Test and Test-setup (Drawings)	<u>21 - 23</u>
Test-setup (Photographs) at worst case	<u>24</u>
B) Test data	
Conducted Emission	450 kHz - 30 MHz
	<u>N/A</u>
Electromagnetic Field Radiated Emission	9 kHz - 25 GHz
	<u>25 - 29</u>
Maximum Peak Power (EIRP)	<u>30</u>
Transmitter Power (TP)	<u>31</u>
Calculated Antenna Gain of the EUT	<u>32</u>
Peak Spectral Power Density	<u>33 - 36</u>
Band-edge Emission	<u>37 - 39</u>

TEST REGULATION

FCC Rules and Regulations Part 15 Subpart A and C (February 28, 2001)

- Class A Digital Device
- Class B Digital Device
- Intentional Radiator(Sec.15.247※)
- Receiver

※ The proposed rule changes(Sec.15.247) in the FCC ET Docket No. 01-158 is applied to the EUT at request of the applicant.

Test items:

- Sec.15.203 : Antenna requirement
- Sec.15.205 : Restricted bands of operation
- Sec.15.207 : Conducted limits
- Sec.15.209 : Radiated emission limits general requirements
- Sec.15.214 : Cordless Telephones
- Sec.15.247 : Operation within the bands 902-928MHz, 2400-2483.5MHz, 5725-5875MHz, and 24.0-24.25GHz

Test procedure:

Radiated emission test was performed according to the procedures in ANSI C63.4-1992.

GENERAL INFORMATION

Test facility:

- 1) Test Facility located at Kita-Kansai : 1st and 2nd Open Sites (3 m Site)
Test Facility located at Kameoka : 1st Open Site (3, 10 and 30 m, on common plane)
: 2nd Open Site (3 and 10 m, on common plane)

FCC filing No. : 31040/SIT 1300F2

- 2) KITA-KANSAI TESTING CENTER is recognized under the National Voluntary Laboratory Accreditation Program for satisfactory compliance established in Title 15, Part 285 Code of Federal Regulations.

NVLAP Lab Code: 200191-0

- 3) Average Measurement Method
FCC filing No. : 950523A 1300F2

Definitions for symbols used in this test report:

- Black box indicates that the listed condition, standard or equipment is applicable for this Report.
- Blank box indicates that the listed condition, standard or equipment is not applicable for this Report.

Description of the Equipment Under Test (EUT):

- 1) Name : 2.4GHz Digital Cordless Telephone(Handset)
- 2) Model/Type No. : KX-TG2257
- 3) Product Type : Pre-Production (S/N: ---)
- 4) Category : Intentional Radiator
- 5) EUT Authorization : - Verification - Certification - D.o.C.
- 6) Transmitting Frequency : 2402.048 MHz(14ch) - 2479.872 MHz(166ch)
- 7) Receiving Frequency : 2402.048 MHz(14ch) - 2479.872 MHz(166ch)
- 8) Method/System : Digital Modulation Systems
- 9) Type of Antenna : J-Type Antenna
- 10) Antenna Gain : 0 dBi
- 11) Measured MAX Output Power : 6.6 mW(EIRP)
- 12) Power Rating : DC 3.6V(Ni-Cd Battery Pack, Model No. : N4HKGMA0001)

Detailed Transmitter portion(Channel plan):

Transmitting frequency : 2402.048 MHz(14ch) - 2479.872 MHz(166ch)
 Number of channel : 153
 Channel Separation : 512 kHz

CH	0	1	2	3	4	5	6	7	8	9
10	--	--	--	--	2402.048	2402.560	2403.072	2403.584	2404.096	2404.608
20	2405.120	2405.632	2406.144	2406.656	2407.168	2407.680	2408.192	2408.704	2409.216	2409.728
30	2410.240	2410.752	2411.264	2411.776	2412.288	2412.800	2413.312	2413.824	2414.336	2414.848
40	2415.360	2415.872	2416.384	2416.896	2417.408	2417.920	2418.432	2418.944	2419.456	2419.968
50	2420.480	2420.992	2421.504	2422.016	2422.528	2423.040	2423.552	2424.064	2424.576	2425.088
60	2425.600	2426.112	2426.624	2427.136	2427.648	2428.160	2428.672	2429.184	2429.696	2430.208
70	2430.720	2431.232	2431.744	2432.256	2432.768	2433.280	2433.792	2434.304	2434.816	2435.328
80	2435.840	2436.352	2436.864	2437.376	2437.888	2438.400	2438.912	2439.424	2439.936	2440.448
90	2440.960	2441.472	2441.984	2442.496	2443.008	2443.520	2444.032	2444.544	2445.056	2445.568
100	2446.080	2446.592	2447.104	2447.616	2448.128	2448.640	2449.152	2449.664	2450.176	2450.688
110	2451.200	2451.712	2452.224	2452.736	2453.248	2453.760	2454.272	2454.784	2455.296	2455.808
120	2456.320	2456.832	2457.344	2457.856	2458.368	2458.880	2459.392	2459.904	2460.416	2460.928
130	2461.440	2461.952	2462.464	2462.976	2463.488	2464.000	2464.512	2465.024	2465.536	2466.048
140	2466.560	2467.072	2467.584	2468.096	2468.608	2469.120	2469.632	2470.144	2470.656	2471.168
150	2471.680	2472.192	2472.704	2473.216	2473.728	2474.240	2474.752	2475.264	2475.776	2476.288
160	2476.800	2477.312	2477.824	2478.336	2478.848	2479.360	2479.872	--	--	--

Modulation System Information:

Modulation : Digital Modulation
 Emission Designator : F1E
 Type : TDD-FSK
 Deviation : 60 kHz
 Bit Rate : 128 Kbps
 Time-division duplex(TDD) Frame format:
 The TDD frame is 2msec in length, and is composed of two symmetrical 828µsec TX and RX subframe.
 Each subframe contains 106 bits of 7.8µsec duration, with 172 µsec gap times between both TX and RX subframe.
 Digital Security Code : 28bits

Detailed Receiver portion:

Receiving frequency : 2402.048 MHz(14ch) - 2479.872 MHz(166ch)
 Local frequency : 2400.768 MHz(14ch) - 2478.592 MHz(166ch)
 Intermediate frequency : 1.28 MHz

The used (generated) frequencies in the EUT:

Reference Clock : 8.192 MHz, 106.496 MHz

TEST CONDITIONS

AC Powerline Conducted Emission Measurement(Sec.15.207(a))
was performed in the following test site.

Test location:

KITA-KANSAI Testing Center

7-7, Ishimaru, 1-Chome, Mino-Shi, Osaka, 562-0027, Japan

○ - Shielded room

KAMEOKA EMC Branch

9-1, Ozaki, Inukanno, Nishibetsuin-Cho, Kameoka-Shi, Kyoto, 621-0126, Japan

○ - Shielded room

○ - On metal plane of open site

Used test instruments and sites:

Model No.	Device ID	Last Cal. Date	Cal. Interval
○ - ESCS 30	A - 1		
○ - ESH 2	A - 2		
○ - ESH 2	A - 3		
○ - KNW-407	D - 6		
○ - KNW-408	D - 11		
○ - KNW-242	D - 7		
○ - ESH3-Z5	D - 12		
○ - KNW-341C	D - 13		
○ - KNW-408	D - 14		
○ - KNW-244C	D - 77		
○ - KNW-408	D - 78		
○ - ESH2-Z5	D - 10		
○ - ESH2-Z3	D - 17		
○ - 65 BNC-50-0-1	H - 26		
○ - 65 BNC-50-0-1	H - 27		
○ - Cable	H - 7		
○ - Cable	H - 8		

Environmental conditions:

Temperature: _____ °C Humidity: _____ %

Magnetic Field Radiated Emission Measurement(Sec.15.247(c),15.205(a),15.209(a))

was performed in the frequency range of 9 kHz - 30 MHz, in the following test site.

Test location:

KITA-KANSAI Testing Center

7-7, Ishimaru, 1-Chome, Mino-Shi, Osaka, 562-0027, Japan

● - 1st open test site (3 meters)

○ - 2nd open test site (3 meters)

KAMEOKA EMC Branch

9-1, Ozaki, Inukanno, Nishibetsuin-Cho, Kameoka-Shi, Kyoto, 621-0126, Japan

○ - 1st open test site ○ - 3 m ○ - 10 m ○ - 30 m

○ - 2nd open test site ○ - 3 m ○ - 10 m

Used test instruments:

Model No.	Device ID	Last Cal. Date	Cal. Interval
● - ESCS 30	A - 1	August, 2001	1 Year
○ - ESH 2	A - 2		
○ - ESH 2	A - 3		
● - HFH2-Z2	C - 2	July, 2001	1 Year
○ - HFH2-Z2	C - 3		

Environmental conditions:

Temperature: 23 °C Humidity: 45 %

Electromagnetic Field Radiated Emission Measurement(Sec.15.247(c),15.205(a),15.209(a))

was performed in horizontal and vertical polarization, in the frequency range of 30 MHz - 1000 MHz, in the following test site.

Test location:

KITA-KANSAI Testing Center

7-7, Ishimaru, 1-Chome, Mino-Shi, Osaka, 562-0027, Japan

- 1st open test site (3 meters)

- 2nd open test site (3 meters)

KAMEOKA EMC Branch

9-1, Ozaki, Inukanno, Nishibetsuin-Cho, Kameoka-Shi, Kyoto, 621-0126, Japan

- 1st open test site - 3 m - 10 m - 30 m

- 2nd open test site - 3 m - 10 m

Validation of Site Attenuation:

1) Last Confirmed Date : October 9, 2001

2) Interval : 1 Year

Used test instruments:

Model No.	Device ID	Last Cal. Date	Cal. Interval
<input type="radio"/> - ESV/ESV-Z3	A - 7 / A - 17		
<input checked="" type="radio"/> - ESV/ESV-Z3	A - 6 / A - 18	December, 2000	1 Year
<input type="radio"/> - ESV/ESV-Z3	A - 4 / A - 20		
<input type="radio"/> - ESV/ESV-Z3	A - 8 / A - 19		
<input type="radio"/> - ESVS 10	A - 5		
<input type="radio"/> - KBA-511A	C - 12		
<input type="radio"/> - KBA-611	C - 22		
<input checked="" type="radio"/> - KBA-511A	C - 13	November, 2001	1 Year
<input checked="" type="radio"/> - KBA-611	C - 19	November, 2001	1 Year
<input type="radio"/> - KBA-511A	C - 11		
<input type="radio"/> - KBA-611	C - 21		
<input type="radio"/> - Cable	H - 1		
<input type="radio"/> - Cable	H - 2		
<input type="radio"/> - Cable	H - 5		
<input checked="" type="radio"/> - Cable	H - 6	November, 2000	1 Year
<input type="radio"/> - Cable	H - 9		

Environmental conditions:

Temperature: 10 °C Humidity: 45 %

**Electromagnetic Field Radiated Emission Measurement(Sec.15.247(c),15.205(a),15.209(a))
Maximum Peak Power (EIRP) Measurement(Sec.15.247(b)(3))**

was performed in horizontal and vertical polarization, in the frequency range of 1 GHz - 25 GHz, in the following test site.

Test location:

KITA-KANSAI Testing Center

7-7, Ishimaru, 1-Chome, Mino-Shi, Osaka, 562-0027, Japan

● - 1st open test site (3 meters)

○ - 2nd open test site (3 meters)

KAMEOKA EMC Branch

9-1, Ozaki, Inukanno, Nishibetsuin-Cho, Kameoka-Shi, Kyoto, 621-0126, Japan

○ - 1st open test site ○ - 3 m ○ - 10 m ○ - 30 m

○ - 2nd open test site ○ - 3 m ○ - 10 m

Used test instruments:

Model No.	Device ID	Last Cal. Date	Cal. Interval
● - ESCS 30	A - 1	August, 2001	1 Year
● - 8566B	A - 13	December, 2000	1 Year
○ - 8593A	A - 15		
○ - ESV	A - 6		
● - 4T-10	D - 73	May, 2001	1 Year
○ - 4T-10	D - 74		
● - 2-10	D - 79	September, 2001	1 Year
● - WJ-6611-513	A - 23	May, 2001	1 Year
● - WJ-6882-824	A - 21	May, 2001	1 Year
● - DBL-0618N515	A - 33	May, 2001	1 Year
● - 91888-2	C - 41 - 1	May, 2001	1 Year
● - 91889-2	C - 41 - 2	May, 2001	1 Year
○ - 94613-1	C - 41 - 3		
○ - 91891-2	C - 41 - 4		
○ - 94614-1	C - 41 - 5		
○ - 3160-04	C - 55		
● - 3160-05	C - 56	May, 2001	1 Year
● - 3160-06	C - 57	May, 2001	1 Year
● - 3160-07	C - 58	May, 2001	1 Year
● - 3160-08	C - 59	May, 2001	1 Year
● - 3160-09	C - 48	November, 2001	1 Year
● - 355C	D - 22	March, 2001	1 Year
● - 355D	D - 23	March, 2001	1 Year
● - MZ5010C	D - 81	November, 2001	1 Year
● - 8673D	B - 2	April, 2001	1 Year
● - Cable	C - 40 - 11	May, 2001	1 Year
● - Cable	C - 40 - 12	May, 2001	1 Year

Environmental conditions:

Temperature: 23 °C Humidity: 45 %

Transmitter Power(TP) Measurement (Sec.15.247(b)(3))

Test Procedure :

The measurement test-setup is shown in the figure. The modulation is set to page 14.

The setting of the spectrum analyzer are shown as follows :

Res. Bandwidth : 1 MHz
Video Bandwidth : 3 MHz
Span : 0 Hz
Sweep Time : 20 msec
Trace : Maxhold

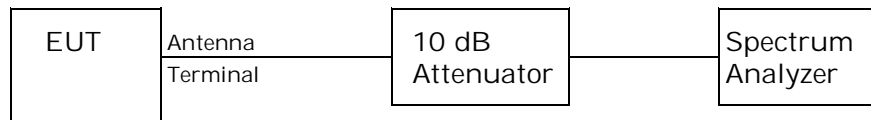

Test location :

KITA-KANSAI Testing Center

7-7, Ishimaru, 1-Chome, Mino-Shi, Osaka, 562-0027, Japan

● - Shielded room

KAMEOKA EMC Branch

9-1, Ozaki, Inukanno, Nishibetsuin-Cho, Kameoka-Shi, Kyoto, 621-0126, Japan

○ - Shielded room

Used test instruments and sites :

Model No.	Device ID	Last Cal. Date	Cal. Interval
● - 8566B	A - 13	December, 2000	1 Year
○ - 432B/8478B	B - 24/B-43		
○ - 6-20	D - 27	September, 2001	1 Year
● - 2-10	D - 79		
○ - 4T-10	D - 73		
○ - 4T-10	D - 74		
○ - 8593A	A - 15		

Environmental conditions :

Temperature: 23 °C Humidity: 48 %

Peak Power Spectral Density Measurement(Sec.15.247(d))

Test Procedure :

The measurement test-setup is shown in the figure. The modulation is set to page 14.

The setting of the spectrum analyzer are shown as follows :

Res. Bandwidth : 3 kHz
Video Bandwidth : 30 kHz
Span : 1 MHz
Sweep Time : AUTO
Trace : Maxhold

Used test instruments:

Model No.	Device ID	Last Cal. Date	Cal. Interval
● - 8566B	A - 13	December, 2000	1 Year
● - 2-10	D - 79	September, 2001	1 Year
○ - 4T-10	D - 73		
○ - 4T-10	D - 74		

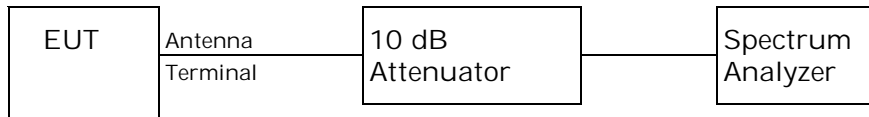

Environmental conditions:

Temperature: 23 °C Humidity: 48 %

Band-edge Emission Measurement(§15.247(c))

Test Procedure :

The measurement test-setup is shown in the figure. The modulation is set to page 14.
The setting of the spectrum analyzer are shown as follows :

Center Frequency : 2400 MHz / 2483.5 MHz
Res. Bandwidth : 100 kHz
Video Bandwidth : 300 kHz
Span : 2 MHz
Sweep Time : AUTO
Trace : Maxhold

Used test instruments:

● - 8566B	A - 13	December, 2000	1 Year
● - 2-10	D - 79	September, 2001	1 Year
○ - 4T-10	D - 73		
○ - 4T-10	D - 74		

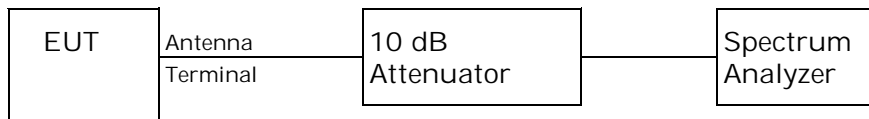

Environmental conditions:

Temperature: 23 °C Humidity: 48 %

CONFIGURATION OF EUT

The Equipment Under Test (EUT) consists of:

Description	Applicant (Manufacturer)	Model No. (Serial No.)	FCC ID
2.4GHz Digital Cordless Telephone (Handset)	Kyushu Matsushita Electric Co., Ltd. (Kyushu Matsushita Electric Co., Ltd.)	KX-TG2257 (--)	ACJ96NKX-TG2257

The measurement was carried out with the following equipment connected:

Description	Grantee/Distributor	Model No. (Serial No.)	FCC ID
Headset	Kyushu Matsushita Electric Co., Ltd.	KX-TCA88 (--)	N/A

Type of Interference Cable(s) and the AC Power Cord used with the EUT:

	Description	Port	Shielded Cable	Shell Material	Ferrite Core	Cable Length
1	EUT	Headset	NO	--	NO	1.4 m
	Headset	--		--		

Operation - mode of the EUT:

The EUT was operated during the test under the following specification:

Transmitting (Modulation signal : random digital signal)

For operating condition of the EUT, the typical modulating signal is not used and inputted because the occupied bandwidth of the EUT is subject to restriction due to the bit rate of preamble data other than audio data in the transmitting data .

Test system:

The EUT has one port, one Headset jack.

Special accessories:

None

TEST RESULTS

AC Powerline Conducted Emission 450 kHz - 30 MHz(Sec.15.207(a))

The requirements are - **Passed** - **Not Passed**
Min. limit margin _____ dB at _____ MHz
Max. limit exceeding _____ dB at _____ MHz
Uncertainty of measurement results _____ dB(2 σ) _____ dB(2 σ)

Remarks: Not Applicable

Electromagnetic Field Radiated Emission 9 kHz - 25 GHz

Maximum Peak Power (EIRP)(Sec.15.247(b)(3))

The requirements are - **Passed** - **Not Passed**
Maximum Peak Power (EIRP) 6.6 mW at 2402.048 MHz

Spurious(Sec.15.247(c),15.205(a),15.209(a))

The requirements are - **Passed** - **Not Passed**
Min. limit margin 7.9 dB at 4804.096 MHz
and at 4881.920 MHz
Max. limit exceeding _____ dB at _____ MHz
Uncertainty of measurement results (\leq 30 MHz) + 2.5 dB(2 σ) - 2.5 dB(2 σ)
Uncertainty of measurement results (30 MHz - 1000 MHz) + 4.9 dB(2 σ) - 5.0 dB(2 σ)
Uncertainty of measurement results (\geq 1000 MHz) + 3.1 dB(2 σ) - 3.2 dB(2 σ)

Remarks: _____

Transmitter Power(TP)(Sec.15.247(b)(3))

The requirements are	● - Passed	○ - Not Passed
The transmitter power is	<u>5.6</u> mW at <u>2402.048</u> MHz	
Min. limit margin	<u>22.5</u> dB at <u>2402.048</u> MHz	
Max. limit exceeding	<u> </u> dB at <u> </u> MHz	
Uncertainty of measurement results	<u>+0.6</u> dB(2σ)	<u>-0.6</u> dB(2σ)

Remarks: _____

Antenna Gain of the EUT(Sec.15.247(b)(4))

The antenna gain is 1.3 dBi at 2440.960 MHz

Remarks: _____

Peak Power Spectral Density(Sec.15.247(d))

The requirements are	● - Passed	○ - Not Passed
The Peak Power Spectral Density is	<u>3.7</u> dBm at <u>2401.986</u> MHz	
The results	Refer to pages	33 - 36
Min. limit margin	<u>4.3</u> dB at <u>2401.986</u> MHz	
Max. limit exceeding	<u> </u> dB at <u> </u> MHz	
Uncertainty of measurement results at Frequency	<u>±0.05</u> ppm(2σ)	
Uncertainty of measurement results at Amplitude	<u>±0.6</u> dB(2σ)	

Remarks: _____

Band-edge Emission(Sec.15.247(c))

The requirements are

● - **Passed** ○ - **Not Passed**

The results

Refer to pages 37 - 39

Uncertainty of measurement results at Frequency

±0.05 ppm(2σ)

Uncertainty of measurement results at Amplitude

±0.6 dB(2σ)

Remarks: _____

SUMMARY

GENERAL REMARKS :

The EUT was tested according to the requirements of FCC Rules and Regulations Part 15 Subpart A and C (February 28, 2001)* under the test configuration, as shown in page 20.

※ However, the proposed rule changes(Sec.15.247) in the FCC ET Docket No. 01-158 is applied to the EUT at request of the applicant.

The conclusion for the test items of which are required by the applied regulation is indicated under the final judgement.

FINAL JUDGEMENT :

The "as received" sample;

- - fulfill the test requirements of the regulation mentioned on page 3.
- - fulfill the test requirements of the regulation mentioned on page 3, but with certain qualifications.
- - doesn't fulfill the test regulation mentioned on page 3.

Begin of testing : November 30, 2001

End of testing : December 5, 2001

- JAPAN QUALITY ASSURANCE ORGANIZATION -

Approved by :

Issued by :



Akio Hosoda
Manager
EMC Div.
JQA KITA-KANSAI Testing Center

Shigeru Kinoshita
Deputy Manager
EMC Div.
JQA KITA-KANSAI Testing Center

Test System-Arrangement (Drawings)

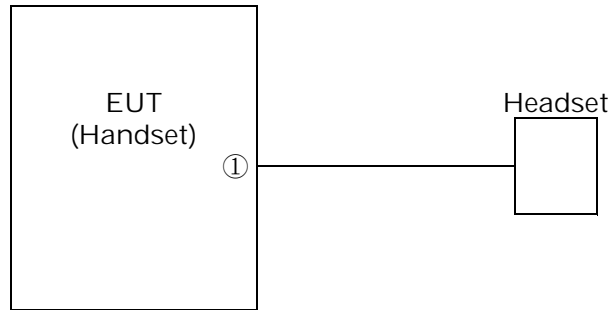

Power Supply : DC3.6V(Ni-Cd Battery Pack : N4HKGMA0001)

Note) ① : Headset jack

Preliminary Test and Test-setup(Drawings)

Radiated Emission (Magnetic Field) 9 kHz - 30 MHz:

The preliminary test was performed according to the description of ANSI C63.4-1992 Sec.8.3.1.1 (Preliminary Radiated Emissions Tests) and Sec.6.2.1 (Tabletop Equipment Tests).

The preliminary test was carried out to investigate the frequency of the emission that has the highest amplitude relative to the limits within normal operating modes, cable positions, and a typical system configuration. In order to find out to the maximum emission, the preliminary test and a final test were performed in accordance with the following steps.

Step 1: One operation mode of the test system was setting.

Step 2: In order to investigate the frequencies of maximum emissions, the loop antenna position was approached to the EUT and the significant frequency of the emission's circumstance from the test system were investigated. These data were recorded in the specified frequency band (9 kHz - 30 MHz).

Step 3: Using a test receiver and a loop antenna, the emission's circumstance from the test system was measured in according with ANSI C63.4-1992 Sec.8.3.1.2 (Final Radiated Emissions Tests) at each frequency which was found the higher emission referred to level vs. frequency on the list and which was measured by the loop antenna. The maximum emission was found by rotating three orthogonal axes or by changing the cable positions or cable manipulation under a typical system configuration.

Step 4: Return to step 1, if the other operation mode was possible to be setting.

Step 5: The worst result was reported arranging data of which was obtained and performed by one or plural operation modes as the final test.

At the worst point that has the highest amplitude relative to the limit the repeatability of the level was reconfirmed. The photographs of the tests system setup on the worst point were taken and recorded.

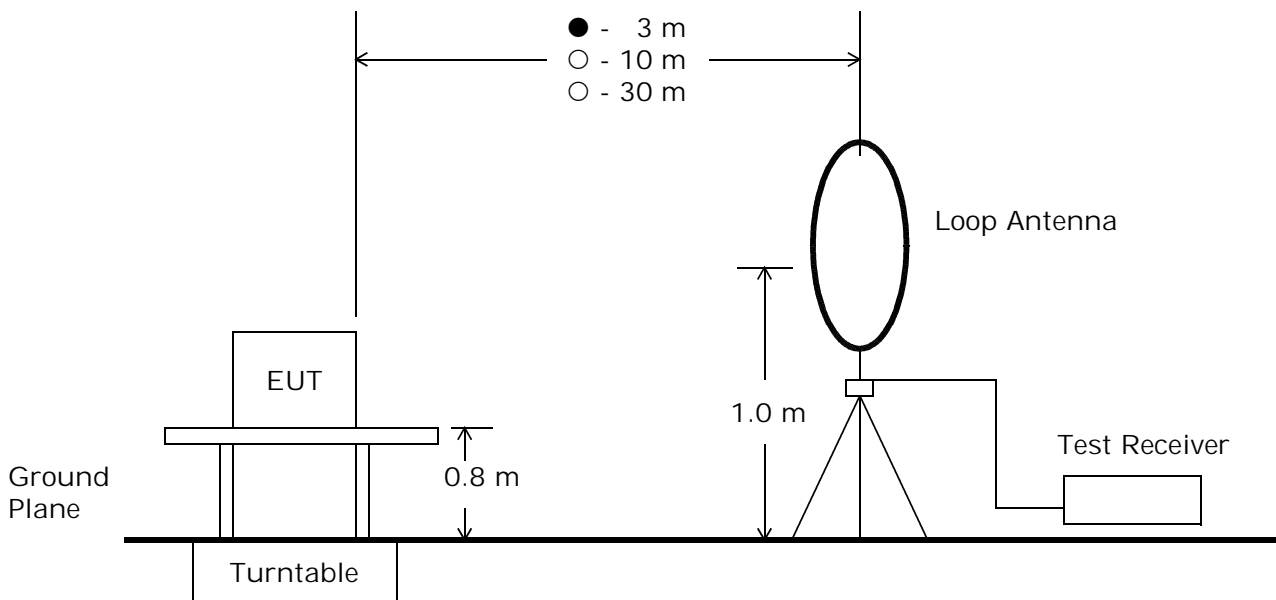

Electromagnetic Field Radiated Emission 30 MHz - 1000 MHz:

The preliminary test was performed according to the description of ANSI C63.4-1992 Sec.8.3.1.1 (Preliminary Radiated Emissions Tests) and Sec.6.2.1 (Tabletop Equipment Tests).

The preliminary test was carried out to investigate the frequency of the emission that has the highest amplitude relative to the limits within normal operating modes, cable positions, and a typical system configuration. In order to find out to the maximum emission, the preliminary test and a final test were performed in accordance with the following steps.

Step 1: One operation mode of the test system was setting.

Step 2: Using a test receiver and a test antenna probe, the significant frequency of the emission's circumstance from the test system were investigated. These data were recorded every one of 22 divided bands in the specified frequency band (30 MHz - 1000 MHz).

Step 3: Using a test receiver and a resonant tuned dipole antenna, the emission's circumstance from the test system was measured in according with ANSI C63.4-1992 Sec.8.3.1.2 (Final Radiated Emissions Tests) at each frequency which was found the higher emission referred to level vs. frequency on the list and which was measured by the resonant tuned dipole antenna. The maximum emission was found by rotating three orthogonal axes or by changing the cable positions or cable manipulation under a typical system configuration.

Step 4: Return to step 1, if the other operation mode was possible to be setting.

Step 5: The worst result was reported arranging data of which was obtained and performed by one or plural operation modes as the final test.

At the worst point that has the highest amplitude relative to the limit the repeatability of the level was reconfirmed. The photographs of the tests system setup on the worst point were taken and recorded.

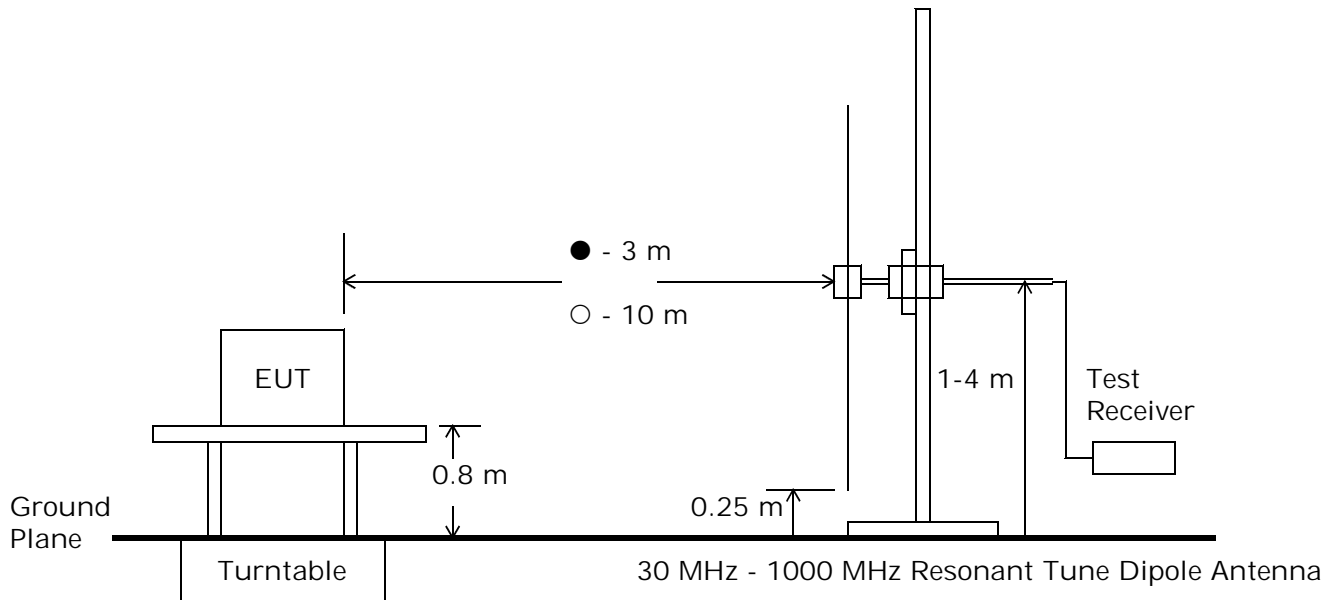

Electromagnetic Field Radiated Emission 1 GHz - 25 GHz:

The preliminary test was performed according to the description of ANSI C63.4-1992 Sec.8.3.1.1 (Preliminary Radiated Emissions Tests) and Sec.6.2.1 (Tabletop Equipment Tests).

The preliminary test was carried out to investigate the frequency of the emission that has the highest amplitude relative to the limits within normal operating modes, cable positions, and a typical system configuration. In order to find out to the maximum emission, the preliminary test and a final test were performed in accordance with the following steps.

Step 1: One operation mode of the test system was setting.

Step 2: In order to investigate the frequencies of maximum emissions, the horn antenna position was approached to the EUT and the significant frequency of the emission's circumstance from the test system were investigated. These data were recorded in the specified frequency band (1 GHz - 25 GHz).

Step 3: The emission's circumstance from the test system was measured in accordance with ANSI C63.4-1992, Sec.8.3.1.2 (Final Radiated Emissions Tests) at each frequency which was found higher emission referred to level vs. frequency on the list and which was measured in the specified distance using the horn antenna. The maximum emission was found by rotating three orthogonal axes or by changing the cable positions or cable manipulation under a typical system configuration.

Step 4: Return to step 1, if the other operation mode was possible to be setting.

Step 5: The worst result was reported arranging data of which was obtained and performed by one or plural operation modes as the final test.

At the worst point that has the highest amplitude relative to the limit the repeatability of the level was reconfirmed. The photographs of the tests system setup on the worst point were taken and recorded.

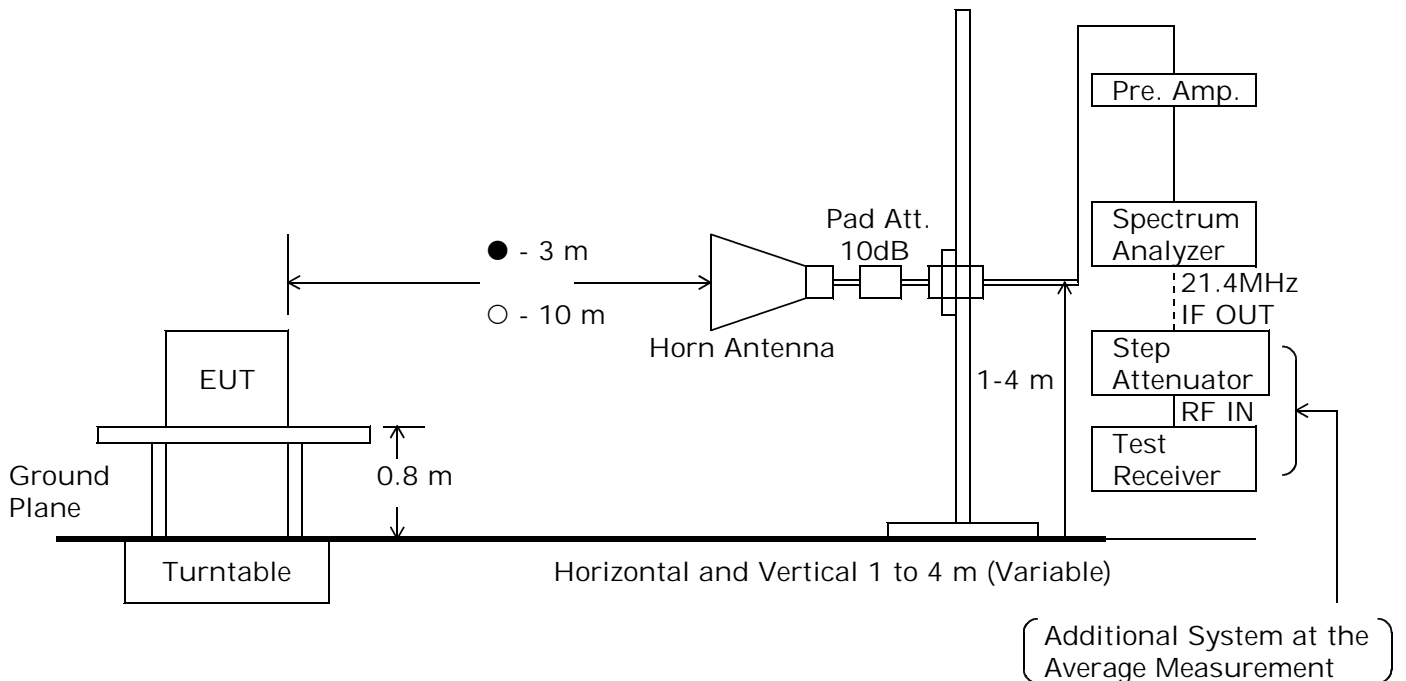

Spectrum Analyzer Setting:

Detector	*)Peak/Average
RES BW	1 MHz
VIDEO BW	1 MHz
SPAN	0 Hz

Test Receiver Setting:

SCALE	LINEAR	LINEAR
I.F.B.W.	1 MHz	1 MHz
Detector	Average	Peak

*) For the average measurement, it is made using a test receiver and a step attenuator.

Test-Setup (Photographs) at worst case

Conducted Emission 450kHz - 30MHz:

Radiated Emission 9 kHz - 25 GHz

Not Applicable



Horizontal polarization



Vertical polarization

Electromagnetic Field Radiated Emission Measurement
 Intentional Radiator
 Spurious emission (9kHz - 1GHz)

Test Date: November 30, 2001
 Temp.: 10 °C ; Humi.: 45 %

Transmitting Frequency : 2440.960 MHz (90 ch)

Frequency [MHz]	Antenna Factor [dB(1/m)]	Cable Loss [dB]	Meter Readings [dB(μV)]		Limits [dB(μV/m)]	Results [dB(μV/m)]		Margin [dB]	Remarks (Note 2)
			Hori.	Vert.		Hori.	Vert.		
49.1	2.7	0.8	< 6.0	< 6.0	40.0	< 9.5	< 9.5	> +30.5	C
65.5	5.2	0.8	10.0	4.0	40.0	16.0	10.0	+24.0	C
213.0	15.5	1.5	< 0.0	< 0.0	43.5	< 17.0	< 17.0	> +26.5	C
245.8	16.7	1.6	4.0	< 0.0	46.0	22.3	< 18.3	+23.7	C
254.0	17.0	1.6	< 0.0	< 0.0	46.0	< 18.6	< 18.6	> +27.4	C
319.5	19.0	1.9	7.0	< 0.0	46.0	27.9	< 20.9	+18.1	C
368.5	20.4	2.0	< -1.0	< -1.0	46.0	< 21.4	< 21.4	> +24.6	C
393.2	21.0	2.1	11.0	7.0	46.0	34.1	30.1	+11.9	C
442.4	22.1	2.4	1.0	< 0.0	46.0	25.5	< 24.5	+20.5	C
491.5	23.1	2.4	2.0	3.0	46.0	27.5	28.5	+17.5	C

Sample of calculated result at 393.2 MHz, as the Minimum Margin point:

Antenna Factor = 21.0 dB(1/m)
 +) Cable Loss = 2.1 dB
 Meter Reading = 11.0 dB(μV)
 Result = 34.1 dB(μV/m)

Minimum Margin : 46.0 - 34.1 = 11.9(dB)

The point shown on "____" is the Minimum Margin Point.

Note 1:

- 1)The highest frequency generated or used in the EUT: 2479.872 MHz
- 2)The upper frequency of measurement range : 25 GHz
- 3)The spectrum was scanned 9 kHz to 1 GHz and all emissions not reported were more than 20 dB below the applied limits.

Remarks:

Note 2	Detector Function	IF Bandwidth
A	CISPR QP	200 Hz
B	CISPR QP	9 kHz
C	CISPR QP	120 kHz
D	Average	120 kHz
E	Average	12 kHz
F	Average	7.5 kHz

Electromagnetic Field Radiated Emission Measurement
 Intentional Radiator
 Fundamental and Spurious(above 1 GHz)

Test Date: December 3, 2001
 Temp.: 23 °C ; Humi.: 45 %

Transmitting Frequency : 2402.048 MHz (14ch)

Frequency [MHz]	Antenna Factor [dB(1/m)]	Correction Factor [dB]	Meter Readings at 3m [dB(μV)]		Limits [dB(μV/m)]	Results at 3m [dB(μV/m)]		Margin [dB]	Remarks (Note 2)
			Hori.	Vert.		Hori.	Vert.		
Fundamental									
2402.048	21.6	10.8	65.0	71.0	---	97.4	103.4	---	B
Spurious at Peak Detector									
* 4804.096	27.3	-31.2	60.0	57.0	74.0	56.1	53.1	+17.9	A
7206.144	29.9	-29.5	51.0	49.0	83.4	51.4	49.4	+32.0	B
9608.192	33.4	-27.5	< 40.0	< 40.0	83.4	< 45.9	< 45.9	> +37.5	B
* 12010.240	33.6	-26.7	< 40.0	< 40.0	74.0	< 46.9	< 46.9	> +27.1	A
14412.288	37.1	-26.3	< 40.0	< 40.0	83.4	< 50.8	< 50.8	> +32.6	B
16814.336	37.2	-27.0	< 40.0	< 40.0	83.4	< 50.2	< 50.2	> +33.2	A
* 19216.384	40.2	-28.0	< 40.0	< 40.0	74.0	< 52.2	< 52.2	> +21.8	B
21618.432	40.3	-28.2	< 40.0	< 40.0	83.4	< 52.1	< 52.1	> +31.3	B
24020.480	40.4	-28.3	< 40.0	< 40.0	83.4	< 52.1	< 52.1	> +31.3	B
Spurious at Average Detector									
* 4804.096	27.3	-31.2	50.0	47.0	54.0	46.1	43.1	+ 7.9	C
* 12010.240	33.6	-26.7	< 30.0	< 30.0	54.0	< 36.9	< 36.9	> +17.1	C
* 19216.384	40.2	-28.0	< 30.0	< 30.0	54.0	< 42.2	< 42.2	> +11.8	C

Transmitting Frequency : 2440.960 MHz (90ch)

Frequency [MHz]	Antenna Factor [dB(1/m)]	Correction Factor [dB]	Meter Readings at 3m [dB(μV)]		Limits [dB(μV/m)]	Results at 3m [dB(μV/m)]		Margin [dB]	Remarks (Note 2)
			Hori.	Vert.		Hori.	Vert.		
Fundamental									
2440.960	21.5	10.8	66.0	71.0	---	98.3	103.3	---	B
Spurious at Peak Detector									
* 4881.920	27.3	-31.2	60.0	59.0	74.0	56.1	55.1	+17.9	A
* 7322.880	29.9	-29.4	50.0	54.0	74.0	50.5	54.5	+19.5	A
9763.840	33.5	-27.4	< 40.0	< 40.0	83.3	< 46.1	< 46.1	> +37.2	B
* 12204.800	33.6	-26.6	< 40.0	< 40.0	74.0	< 47.0	< 47.0	> +27.0	A
14645.760	37.1	-26.6	< 40.0	< 40.0	83.3	< 50.5	< 50.5	> +32.8	B
17086.720	37.2	-27.1	< 40.0	< 40.0	83.3	< 50.1	< 50.1	> +33.2	B
* 19527.680	40.3	-27.8	< 40.0	< 40.0	74.0	< 52.5	< 52.5	> +21.5	A
21968.640	40.3	-27.9	< 40.0	< 40.0	83.3	< 52.4	< 52.4	> +30.9	B
24409.600	40.4	-28.7	< 40.0	< 40.0	83.3	< 51.7	< 51.7	> +31.6	B
Spurious at Average Detector									
* 4881.920	27.3	-31.2	50.0	49.0	54.0	46.1	45.1	+ 7.9	C
* 7322.880	29.9	-29.4	43.0	43.0	54.0	43.5	43.5	+10.5	C
* 12204.800	33.6	-26.6	< 30.0	< 30.0	54.0	< 37.0	< 37.0	> +17.0	C
* 19527.680	40.3	-27.8	< 30.0	< 30.0	54.0	< 42.5	< 42.5	> +11.5	C

Transmitting Frequency : 2479.872 MHz (166ch)

Frequency [MHz]	Antenna Factor [dB(1/m)]	Correction Factor [dB]	Meter Readings at 3m [dB(μV)]		Limits [dB(μV/m)]	Results at 3m [dB(μV/m)]		Margin [dB]	Remarks (Note 2)
			Hori.	Vert.		Hori.	Vert.		
Fundamental									
2479.872	21.4	10.8	67.0	69.0	---	99.2	101.2	---	B
Spurious at Peak Detector									
* 4959.744	27.3	-31.3	59.0	57.0	74.0	55.0	53.0	+19.0	A
* 7439.616	30.0	-29.2	55.0	54.0	74.0	55.8	54.8	+18.2	A
9919.488	33.5	-27.3	< 40.0	< 40.0	81.2	< 46.2	< 46.2	> +35.0	B
* 12399.360	33.6	-26.6	< 40.0	< 40.0	74.0	< 47.0	< 47.0	> +27.0	A
14879.232	37.1	-26.6	< 40.0	< 40.0	81.2	< 50.5	< 50.5	> +30.7	B
17359.104	37.2	-27.0	< 40.0	< 40.0	81.2	< 50.2	< 50.2	> +31.0	B
* 19838.976	40.3	-27.4	< 40.0	< 40.0	74.0	< 52.9	< 52.9	> +21.1	A
* 22318.848	40.4	-27.7	< 40.0	< 40.0	81.2	< 52.7	< 52.7	> +28.5	A
24798.720	40.4	-28.8	< 40.0	< 40.0	81.2	< 51.6	< 51.6	> +29.6	B
Spurious at Average Detector									
* 4959.744	27.3	-31.3	49.0	47.0	54.0	45.0	43.0	+ 9.0	C
* 7439.616	30.0	-29.2	42.0	41.0	54.0	42.8	41.8	+11.2	C
* 12399.360	33.6	-26.6	< 30.0	< 30.0	54.0	< 37.0	< 37.0	> +17.0	C
* 19838.976	40.3	-27.4	< 30.0	< 30.0	54.0	< 42.9	< 42.9	> +11.1	C
* 22318.848	40.4	-27.7	< 30.0	< 30.0	54.0	< 42.7	< 42.7	> +11.3	C

Sample of calculated result at 4804.096 MHz, as the Minimum Margin point:

Antenna Factor = 27.3 dB(1/m)
 Corr. Factor = -31.2 dB
 +) Meter Reading = 50.0 dB(μV)
 Result = 46.1 dB(μV/m)

Minimum Margin : 54.0 - 46.1 = 7.9(dB)

The point shown on " ___ " is the Minimum Margin Point.

Note 1:

- 1)The highest frequency generated or used in the EUT: 2479.872 MHz
- 2)The upper frequency of measurement range : 25 GHz
- 3)The spectrum was scanned 1 GHz to 25 GHz and all emissions not reported were more than 20 dB below the applied limits.
- 4)Symbol '**' : Restricted bands of operation in Sec.15.205.
- 5)Corr. Factor [dB] (below 1 GHz) = Cable Loss [dB] + 10 dB Pad Attenuator
 Corr. Factor (Fundamental) = Cable Loss [dB] + 10 dB Pad Attenuator
 Corr. Factor (≤ 18 GHz except Fundamental) = Cable Loss + 10 dB Pad Attenuator - Amp. Gain [dB]
 Corr. Factor (≥ 18 GHz) = Cable Loss - Amp. Gain + Mixer Conversion Loss(at IF=8GHz)[dB]

Remarks:

Note 2	Detector Function	RES. B.W	V.B.W	Sweep T	Span
A	Peak (SP)	1 MHz	1 MHz	20 msec	0 Hz
B	Peak (SP)	100 kHz	300 kHz	20 msec	0 Hz
*) C	Average (Receiver)	1 MHz (1 MHz)	3 MHz	20 msec	0 Hz
D	Peak	1 MHz	3 MHz	20 msec	0 Hz

():Setting of spectrum analyzer

*)For the average/peak measurement method, it is made measurement using a test receiver, a step attenuator or and a spectrum analyzer(FCC REPLY No. 950523A).

Tester : Yasuhisa Sakai

Maximum Peak Power (EIRP) Measurement
 Fundamental Emission

Test Date: December 3, 2001
 Temp.: 23 °C ; Humi.: 45 %

Measurement Results:

Radiated Emission Measurement at 3m

Frequency [MHz]	Antenna Factor [dB(1/m)]	Correction Factor [dB]	Meter Readings at 3m [dB(μV)]		Results at 3m [dB(μV/m)]		Remarks (Note 2)
			Hori.	Vert.	Hori.	Vert.	
Fundamental							
2402.048	21.6	10.8	65.0	71.0	97.4	103.4	A
2440.960	21.5	10.8	66.0	71.0	98.3	103.3	A
2479.872	21.4	10.8	67.0	69.0	99.2	101.2	A

Note : 1. The correction factor includes the attenuator loss and the cable loss.

Remarks:

Note 2	Detector Function	RES. B.W	V.B.W	Sweep T	Span
A	Peak	1 MHz	3 MHz	20 msec	0 Hz

Calculated Results:

CH No.	Frequency (MHz)	Maximum Peak Power EIRP(mW)	
		Hori.	Vert.
14	2402.048	1.6	6.6
90	2440.960	2.0	6.4
166	2479.872	2.5	4.0

The EUT is placed at 3m away from the receiving antenna and the EIRP is calculated using the following formula:

$$E^2 / (120\pi) = \text{EIRP} / (4\pi d^2) \quad \text{where} \quad \text{EIRP} = P_h G_h, \quad E : \text{Field Strength at } d \text{ (distance) m} [\mu\text{V/m}]$$

$$\text{EIRP} = (dE)^2 / 30 \quad G_h = \text{Substituted Antenna [dBi]}$$

$$\text{EIRP(W)} = (3 \times E(\mu\text{V/m}) \times 10^{-6})^2 / 30 \quad P_h = \text{Input power at the Substituted Antenna [W]}$$

The point shown on " ____ " is the Maximum Point.

Tester : Yasuhisa Sakai

Transmitter Power(TP) Measurement

Test Date: December 4, 2001
 Temp.: 23 °C ; Humi.: 48 %

Measurement Results:

CH No.	Frequency (MHz)	Corr. Factor (dB)	Meter Reading (dBm)	Result (dBm)	Result (mW)	Limits (mW)	Margin (dB)	Remarks (Note 2)
14	2402.048	10.8	-3.3	7.5	5.6	1000	+22.5	A
90	2440.960	10.8	-4.0	6.8	4.8	1000	+23.2	A
166	2479.872	10.8	-5.1	5.7	3.7	1000	+24.3	A

Sample of calculated result at 2402.048 MHz, as the Minimum Margin point:

$$\begin{aligned} \text{Correction Factor} &= 10.8 \text{ dB} \\ +) \text{ Meter Reading} &= -3.3 \text{ dBm} \\ \hline \text{Result} &= 7.5 \text{ dBm} \quad ; 10^{(7.5/10)} = 5.6 \text{ (mW)} \end{aligned}$$

Minimum Margin : 30.0 - 7.5 = 22.5(dB)
 The point shown on " ___ " is the Minimum Margin Point.

Note : 1. The correction factor includes the attenuator loss and the cable loss.

Remarks:

Note 2	Detector Function	RES. B.W	V.B.W	Sweep T	Span
A	Peak	1 MHz	3 MHz	20 msec	0 Hz

Tester : Shigeru Kinoshita

Calculated Antenna gain of the EUT

Calculated Results:

Antenna gain of the integrated antenna of the EUT : Geut(dB)
Transmitter power (Measured) : TP(dBm)
EIRP (Measured) : EIRP(dBm)

If the antenna gain(Geut) is met the equations as follows.

$$\begin{aligned} \text{EIRP} &= \text{TP} * \text{Geut} \\ \text{Geut(Numric)} &= \text{EIRP} / \text{TP} \\ \text{Geut(dB)} &= 10\log_{10}(\text{EIRP} / \text{TP}) \end{aligned}$$

CH No.	Frequency (MHz)	EIRP (mW)	TP (mW)	Geut (dBi)
14	2402.048	6.6	5.6	0.7
90	2440.960	6.4	4.8	1.3
166	2479.872	4.0	3.7	0.3

Sample of calculated result at 2440.048 MHz, as the Maximum point:

$$\begin{array}{rcl} \text{EIRP} & = & 8.1 \text{ dBm} = 10\log_{10}(6.4) \\ -) \text{TP} & = & 6.8 \text{ dBm} = 10\log_{10}(4.8) \\ \hline \text{Result} & = & 1.3 \text{ dBi} \end{array}$$

The point shown on "___" is the Maximum Point.

Peak Power Spectral Density Measurement

Test Date: December 4, 2001
 Temp.: 23 °C ; Humi.: 48 %

Measurement Results:

CH No.	Frequency (MHz)	Corr. Factor (dB)	Meter Reading (dBm)	Peak Power Spectral Density (dBm)	Limits (dBm)	Margin (dB)	Attached Garph Page	Remarks (Note 2)
14	2401.986	10.8	-7.1	3.7	8.0	+4.3	page 34	A
90	2440.894	10.8	-7.8	3.0	8.0	+5.0	page 35	A
166	2479.810	10.8	-8.5	2.3	8.0	+5.7	page 36	A

Sample of calculated result at 2401.986 MHz, as the Minimum Margin point:

$$\begin{array}{rcl}
 \text{Correction Factor} & = & 10.8 \text{ dB} \\
 +) \text{ Meter Reading} & = & -7.1 \text{ dBm} \\
 \hline
 \text{Result} & = & 3.7 \text{ dBm}
 \end{array}$$

Minimum Margin : $8.0 - 3.7 = 4.3(\text{dB})$

The point shown on "___" is the Minimum Margin Point.

Note : 1. The correction factor includes the attenuator loss and the cable loss.

Remarks:

Note 2	Detector Function	RES. B.W	V.B.W	Sweep T	Span
A	Peak	3 kHz	30kHz	AUTO	1 MHz

Tester : Shigeru Kinoshita

Peak Power Spectral Density Measurement
Transmitting Frequency : 2402.048 MHz (14 ch)

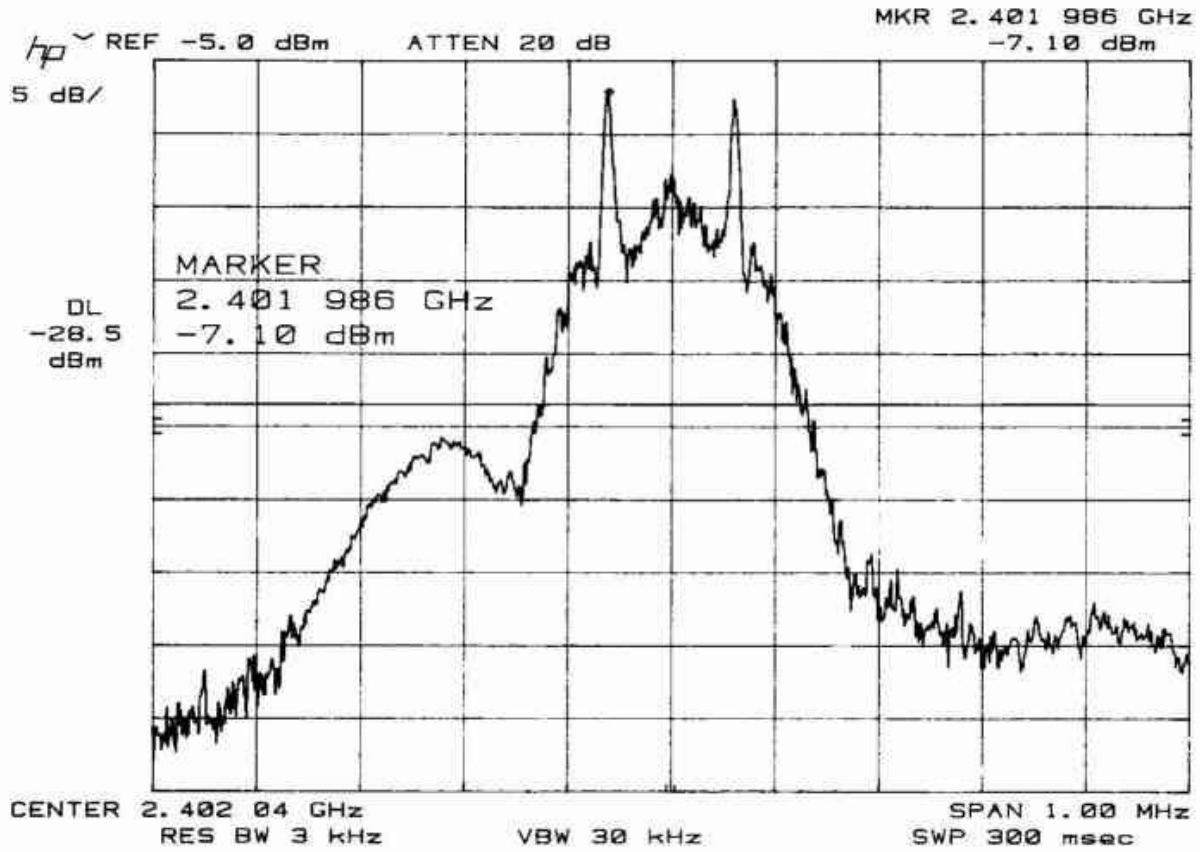

Peak Power Spectral Density Measurement
Transmitting Frequency : 2440.960 MHz (90 ch)

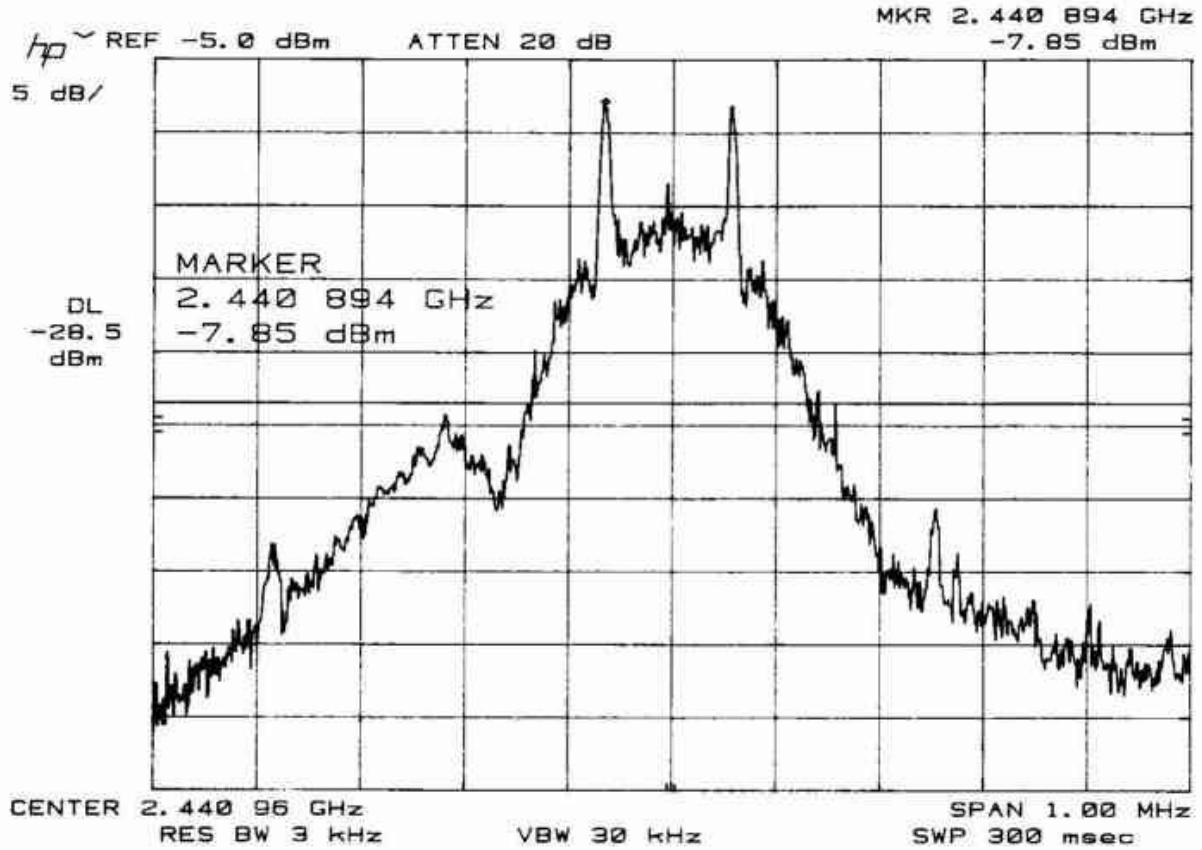

Peak Power Spectral Density Measurement
Transmitting Frequency : 2479.872 MHz (166 ch)

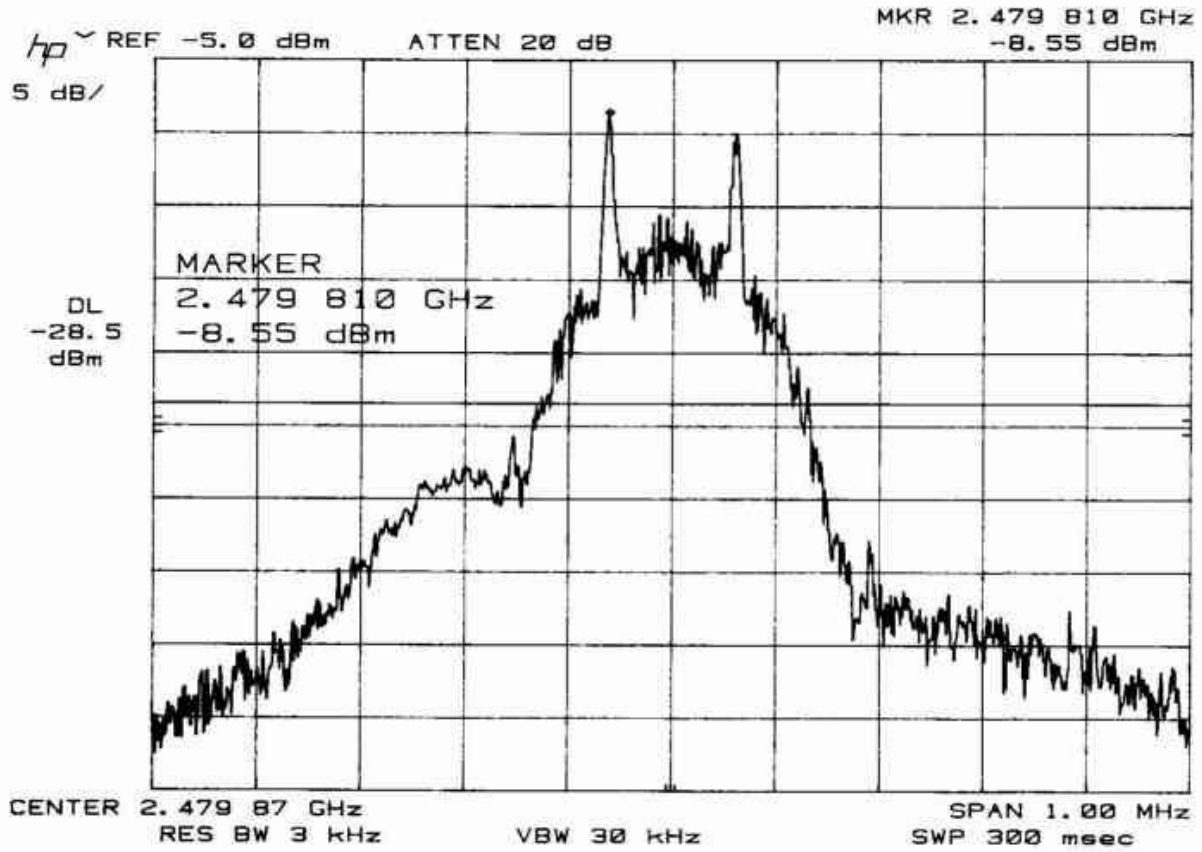

Band-edge Emission Measurement
Fundamental Emission

Test Date: December 4, 2001
Temp.: 23 °C ; Humi.: 48 %

Measurement Results:

CH No.	Frequency (MHz)	Band-edge Frequency (MHz)	Band-edge Level to Peak (dB)	Attached graph page
14	2402.048	2400.000	-45.3	page 38
166	2479.872	2483.500	-52.1	page 39

Tester : Shigeru Kinoshita

Band-edge Emission Measurement

Transmitting Frequency : 2402.048 MHz (14 ch)

Band-edge Frequency : 2400.000 MHz

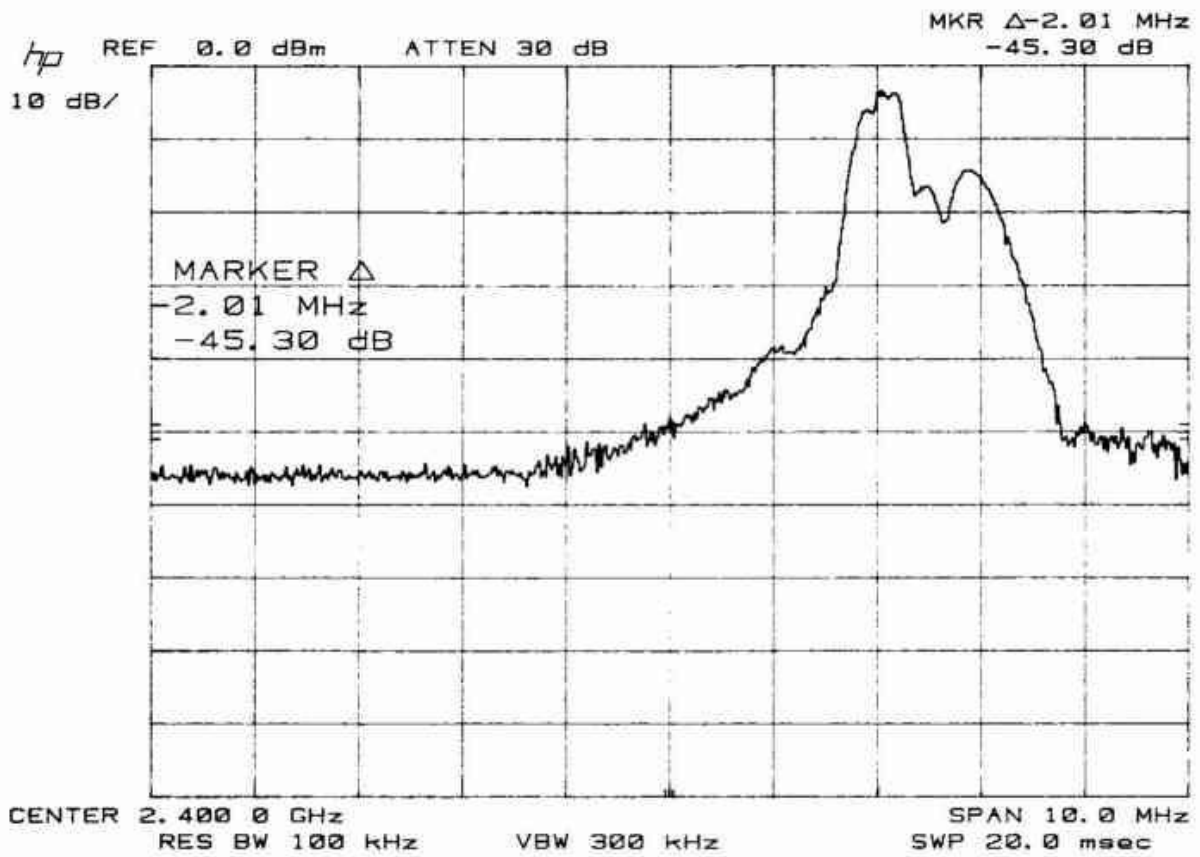

Band-edge Emission Measurement

Transmitting Frequency : 2479.872 MHz (166 ch)

Band-edge Frequency : 2483.500 MHz

