

Similarity between KX-T0151 and KX-TDA0152

RF block are same between KX-T0151 and KX-TDA0152.

There are same circuits and same printed patterns between KX-T0151 and KX-TDA0152.

Base band IC are same between KX-T0151 and KX-TDA0152.

Refer to block diagram of KX-T0151 and KX-TDA0152.

RF characteristics like FCC part15 measurement items are determined by RF block and base band IC.

Therefore RF characteristics like FCC part15 measurement items are same between KX-T0151 and KX-TDA0152.

Similarity between KX-T0151 and KX-TDA0152

KX-T0151 BLOCK DIAGRAM

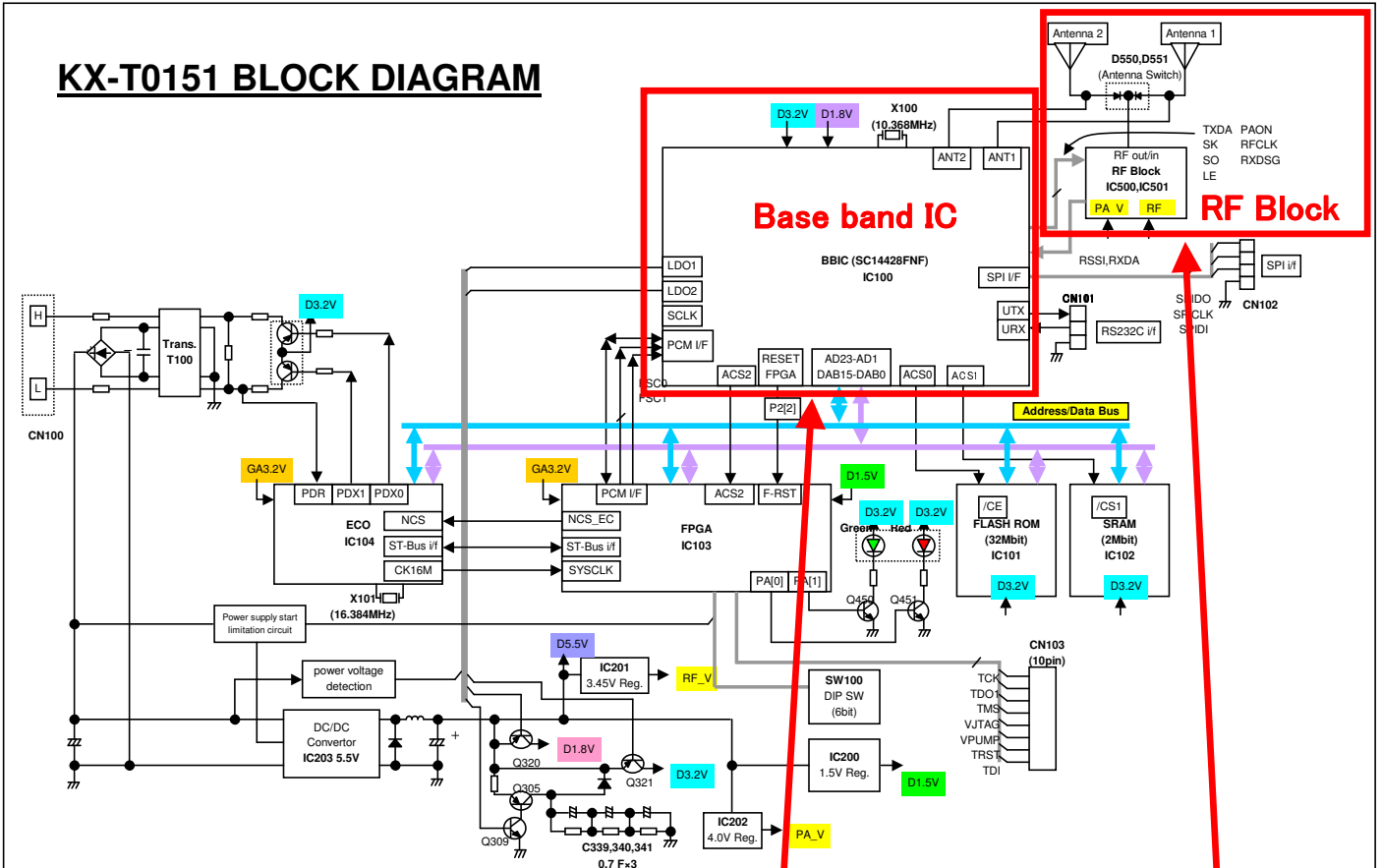

Same

Same

KX-TDA0152 BLOCK DIAGRAM

