

## ***EMC* EMISSION - TEST REPORT**

JQA APPLICATION No. : KL80010362

Name of Product : 2.4GHz Cell Station for PBX

Model/Type No. : KX-TDA0142

FCC ID : ACJ96NKX-TDA0142

Applicant : Kyushu Matsushita Electric Co., Ltd.

Address : 1-62, 4-chome, Minoshima, Hakata-ku, Fukuoka 812-8531, Japan

Manufacturer : Kyushu Matsushita Electric Co., Ltd.

Address : 1-62, 4-chome, Minoshima, Hakata-ku, Fukuoka 812-8531, Japan

Receive date of EUT : September 25, 2001

***Final Judgement*** : Passed

***TEST RESULTS IN THIS REPORT*** are obtained in use of equipment that is traceable to National Institute of Advanced Industrial Science and Technology(AIST) under METI Japan and Communications Research Lab.(CRL) under MPHPT Japan.

***THE TEST RESULTS*** only responds to the test sample. This test report shall not be reproduced except in full.

JAPAN QUALITY ASSURANCE ORGANIZATION (JQA)  
KITA-KANSAI TESTING CENTER  
EMC DIVISION

## **DIRECTORY**

	<b>Page</b>
<b>A) Documentation</b>	
Directory	<u>2</u>
Test Regulation / General Information	<u>3 - 5</u>
Test Conditions	<u>6 - 12</u>
Configuration of EUT / Operation mode of the EUT	<u>13 - 14</u>
EUT Modification / Responsible Party / Deviation from Standard	<u>15</u>
Test results / Measurement Uncertainty	<u>16 - 18</u>
Summary	<u>19</u>
<b>Test System-Arrangement (Drawings)</b>	<u>20</u>
<b>Preliminary Test and Test-setup (Drawings)</b>	<u>21 - 23</u>
<b>Test-setup (Photographs) at worst case</b>	<u>24</u>
<b>B) Test data</b>	
Conducted Emission	450 kHz - 30 MHz
	<u>N/A</u>
Electromagnetic Field Radiated Emission	9 kHz - 25 GHz
	<u>25 - 29</u>
Maximum Peak Power (EIRP)	<u>30</u>
Transmitter Power (TP)	<u>31</u>
Antenna Gain of the EUT	<u>32</u>
-20dB Bandwidth and Band-edge Emission	<u>33 - 38</u>
Carrir Frequencies Seperation	<u>39 -40</u>
Channel Seperation / Dwell Time	<u>43 - 44</u>

## TEST REGULATION

FCC Rules and Regulations Part 15 Subpart A and C (February 28, 2001)

- Class A Digital Device
- Class B Digital Device
- Intentional Radiator(Sec.15.247)
- Receiver

### **Test items:**

- Sec.15.203 : Antenna requirement
- Sec.15.205 : Restricted bands of operation
- Sec.15.207 : Conducted limits
- Sec.15.209 : Radiated emission limits general requirements
- Sec.15.214 : Cordless Telephones
- Sec.15.247 : Operation within the bands 902-928MHz, 2400-2483.5MHz, 5725-5875MHz, and 24.0-24.25GHz

### **Test procedure:**

Radiated emission test was performed according to the procedures in ANSI C63.4-1992.

## GENERAL INFORMATION

### **Test facility:**

- 1) Test Facility located at Kita-Kansai : 1st and 2nd Open Sites (3 m Site)  
Test Facility located at Kameoka Open Site (3, 10 and 30 m, on common plane)  
**FCC filing No. : 31040/SIT 1300F2**
- 2) KITA-KANSAI TESTING CENTER is recognized under the National Voluntary Laboratory Accreditation Program for satisfactory compliance established in Title 15, Part 285 Code of Federal Regulations.  
**NVLAP Lab Code: 200191-0**
- 3) Average Measurement Method  
**FCC filing No. : 950523A 1300F2**

### **Definitions for symbols used in this test report:**

- Black box indicates that the listed condition, standard or equipment is applicable for this Report.
- Blank box indicates that the listed condition, standard or equipment is not applicable for this Report.

**Description of the Equipment Under Test (EUT):**

- 1) Name : 2.4GHz Cell Station for PBX
- 2) Model/Type No. : KX-TDA0142
- 3) Product Type : Pre-Production (S/N: ---)
- 4) Category : Intentional Radiator
- 5) EUT Authorization :  - Verification    - Certification    - D.o.C.
- 6) Transmitting Frequency : 2401.056 MHz(00ch) - 2479.680 MHz(91ch)
- 7) Receiving Frequency : 2401.056 MHz(00ch) - 2479.680 MHz(91ch)
- 8) Method/System : Frequency Hopping Spread System(FHSS)
- 9) Type of Antenna : Half-wave length Dipole Antenna
- 10) Antenna Gain : less than 2.14 dBi
- 11) Typical TX Power : 125.9 mW(21.0 dBm)
- 12) Power Rating : DC40V

**Detailed Transmitter portion(Channel plan):**

Transmitting frequency : 2401.056MHz(00ch) - 2479.680 MHz(91ch)  
 Number of channel : 92  
 Channel Separation : 864 kHz

CH	0	1	2	3	4	5	6	7	8	9
0	2401.056	2401.920	2402.784	2403.648	2404.512	2405.376	2406.240	2407.104	2407.968	2408.832
10	2409.696	2410.560	2411.424	2412.288	2413.152	2414.016	2414.880	2415.744	2416.608	2417.472
20	2418.336	2419.200	2420.064	2420.928	2421.792	2422.656	2423.520	2424.384	2425.248	2426.112
30	2426.976	2427.840	2428.704	2429.568	2430.432	2431.296	2432.160	2433.024	2433.888	2434.752
40	2435.616	2436.480	2437.344	2438.208	2439.072	2439.936	2440.800	2441.664	2442.528	2443.392
50	2444.256	2445.120	2445.984	2446.848	2447.712	2448.576	2449.440	2450.304	2451.168	2452.032
60	2452.896	2453.760	2454.624	2455.488	2456.352	2457.216	2458.080	2458.944	2459.808	2460.672
70	2461.536	2462.400	2463.264	2464.128	2464.992	2465.856	2466.720	2467.584	2468.448	2469.312
80	2470.176	2471.040	2471.904	2472.768	2473.632	2474.496	2475.360	2476.224	2477.088	2477.952
90	2478.816	2479.680								

**Modulation System Information:**

Spread Spectrum Method : Frequency Hopping  
 Modulation : GFSK(Gaussian-shaped Binary Frequency Shift Keying)  
 Hop Rate/Symbol Rate : 100 hops/sec./ 576 Kbps  
 Digital Security Code : 40bits

**Detailed Receiver portion:**

Receiving frequency : 2401.056MHz(00ch) - 2479.680 MHz(91ch)  
 Local frequency : 2400.192MHz(00ch) - 2478.816 MHz(91ch)  
 Intermediate frequency : 864 kHz

**The used (generated) frequencies in the EUT:**

Reference Clock : 10.368 MHz

## TEST CONDITIONS

**AC Powerline Conducted Emission Measurement(Sec.15.207(a))**  
was performed in the following test site.

**Test location:**

KITA-KANSAI Testing Center

7-7, Ishimaru, 1-Chome, Mino-Shi, Osaka, 562-0027, Japan

○ - Shielded room

KAMEOKA EMC Branch

9-1, Ozaki, Inukanno, Nishibetsuin-Cho, Kameoka-Shi, Kyoto, 621-0126, Japan

○ - Shielded room

○ - On metal plane of open site

**Used test instruments and sites:**

Model No.	Device ID	Last Cal. Date	Cal. Interval
○ - ESCS 30	A - 1		
○ - ESH 2	A - 2		
○ - ESH 2	A - 3		
○ - KNW-407	D - 6		
○ - KNW-408	D - 11		
○ - KNW-242	D - 7		
○ - ESH3-Z5	D - 12		
○ - KNW-341C	D - 13		
○ - KNW-408	D - 14		
○ - KNW-244C	D - 77		
○ - KNW-408	D - 78		
○ - ESH2-Z5	D - 10		
○ - ESH2-Z3	D - 17		
○ - 65 BNC-50-0-1	H - 26		
○ - 65 BNC-50-0-1	H - 27		
○ - Cable	H - 7		
○ - Cable	H - 8		

**Environmental conditions:**

Temperature: \_\_\_\_\_ °C      Humidity: \_\_\_\_\_ %

**Magnetic Field Radiated Emission Measurement(Sec.15.247(c),15.205(a),15.209(a))**

was performed in the frequency range of 9 kHz - 30 MHz, in the following test site.

**Test location:**

KITA-KANSAI Testing Center

7-7, Ishimaru, 1-Chome, Mino-Shi, Osaka, 562-0027, Japan

● - 1st open test site (3 meters)

○ - 2nd open test site (3 meters)

KAMEOKA EMC Branch

9-1, Ozaki, Inukanno, Nishibetsuin-Cho, Kameoka-Shi, Kyoto, 621-0126, Japan

○ - 1st open test site                      ○ - 3 m            ○ - 10 m            ○ - 30 m

○ - 2nd open test site                      ○ - 3 m            ○ - 10 m

**Used test instruments:**

Model No.	Device ID	Last Cal. Date	Cal. Interval
○ - ESCS 30	A - 1		
● - ESH 2	A - 2	May, 2001	1 Year
○ - ESH 2	A - 3		
● - HFH2-Z2	C - 2	July, 2001	1 Year
○ - HFH2-Z2	C - 3		

**Environmental conditions:**

Temperature: 23 °C      Humidity: 54 %

**Electromagnetic Field Radiated Emission Measurement(Sec.15.247(c),15.205(a),15.209(a))**

was performed in horizontal and vertical polarization, in the frequency range of 30 MHz - 1000 MHz, in the following test site.

**Test location:**

KITA-KANSAI Testing Center

7-7, Ishimaru, 1-Chome, Mino-Shi, Osaka, 562-0027, Japan

○ - 1st open test site (3 meters)

● - 2nd open test site (3 meters)

KAMEOKA EMC Branch

9-1, Ozaki, Inukanno, Nishibetsuin-Cho, Kameoka-Shi, Kyoto, 621-0126, Japan

○ - 1st open test site                      ○ - 3 m              ○ - 10 m              ○ - 30 m

○ - 2nd open test site                      ○ - 3 m              ○ - 10 m

**Validation of Site Attenuation:**

1) Last Confirmed Date : October 26, 2000

2) Interval : 1 Year

**Used test instruments:**

Model No.	Device ID	Last Cal. Date	Cal. Interval
○ - ESV/ESV-Z3	A - 7 / A - 17		
● - ESV/ESV-Z3	A - 6 / A - 18	December, 2000	1 Year
○ - ESV/ESV-Z3	A - 4 / A - 20		
○ - ESV/ESV-Z3	A - 8 / A - 19		
○ - ESVS 10	A - 5		
○ - KBA-511A	C - 12		
○ - KBA-611	C - 22		
● - KBA-511A	C - 13	November, 2000	1 Year
● - KBA-611	C - 19	November, 2000	1 Year
○ - KBA-511A	C - 11		
○ - KBA-611	C - 21		
○ - Cable	H - 1		
○ - Cable	H - 2		
○ - Cable	H - 5		
● - Cable	H - 6	November, 2000	1 Year
○ - Cable	H - 9		

**Environmental conditions:**

Temperature: 23 °C Humidity: 62 %

**Electromagnetic Field Radiated Emission Measurement(Sec.15.247(c),15.205(a),15.209(a))  
 Maximum Peak Power (EIRP) Measurement(Sec.15.247(b)(1))**

was performed in horizontal and vertical polarization, in the frequency range of 1 GHz - 25 GHz, in the following test site.

**Test location:**

KITA-KANSAI Testing Center

7-7, Ishimaru, 1-Chome, Mino-Shi, Osaka, 562-0027, Japan

● - 1st open test site (3 meters)

○ - 2nd open test site (3 meters)

KAMEOKA EMC Branch

9-1, Ozaki, Inukanno, Nishibetsuin-Cho, Kameoka-Shi, Kyoto, 621-0126, Japan

○ - 1st open test site                      ○ - 3 m              ○ - 10 m              ○ - 30 m

○ - 2nd open test site                      ○ - 3 m              ○ - 10 m

**Used test instruments:**

Model No.	Device ID	Last Cal. Date	Cal. Interval
● - ESCS 30	A - 1	August, 2001	1 Year
● - 8566B	A - 13	December, 2000	1 Year
○ - 8593A	A - 15		
○ - ESV	A - 6		
● - 4T-10	D - 73	May, 2001	1 Year
○ - 4T-10	D - 74		
● - WJ-6611-513	A - 23	May, 2001	1 Year
● - WJ-6882-824	A - 21	May, 2001	1 Year
● - DBL-0618N515	A - 33	May, 2001	1 Year
● - 91888-2	C - 41 - 1	May, 2001	1 Year
● - 91889-2	C - 41 - 2	May, 2001	1 Year
○ - 94613-1	C - 41 - 3		
○ - 91891-2	C - 41 - 4		
○ - 94614-1	C - 41 - 5		
○ - 3160-04	C - 55		
● - 3160-05	C - 56	May, 2001	1 Year
● - 3160-06	C - 57	May, 2001	1 Year
● - 3160-07	C - 58	May, 2001	1 Year
● - 3160-08	C - 59	May, 2001	1 Year
● - 3160-09	C - 48	May, 2001	1 Year
● - 355C	D - 22	March, 2001	1 Year
● - 355D	D - 23	March, 2001	1 Year
○ - 8494H/8595H	D - 76		
● - MZ5010C	D - 81	October, 2000	1 Year
● - 8673D	B - 2	April, 2001	1 Year
● - Cable	C - 40 - 11	May, 2001	1 Year
● - Cable	C - 40 - 12	May, 2001	1 Year

**Environmental conditions:**

Temperature: 28 °C      Humidity: 58 %

### Transmitter Power(TP) Measurement (Sec.15.247(b)(1))

#### Test Procedure :

The Transmitter Power was measured with a spectrum analyzer, one 10 dB attenuator and a short, low loss cable.

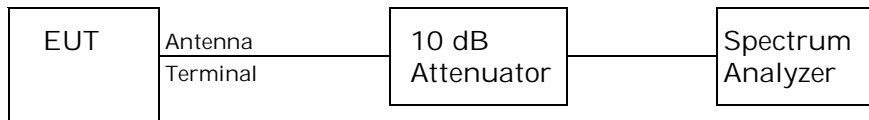

#### Test location :

KITA-KANSAI Testing Center

7-7, Ishimaru, 1-Chome, Mino-Shi, Osaka, 562-0027, Japan

● - Shielded room

KAMEOKA EMC Branch

9-1, Ozaki, Inukanno, Nishibetsuin-Cho, Kameoka-Shi, Kyoto, 621-0126, Japan

○ - Shielded room

#### Used test instruments and sites :

Model No.	Device ID	Last Cal. Date	Cal. Interval
● - 8566B	A - 13	December, 2000	1 Year
○ - 432B/8478B	B - 24/B-43		
○ - 6-20	D - 27	May, 2001	1 Year
● - 4T-10	D - 73		
○ - 4T-10	D - 74		
○ - 8566B	A - 13		
○ - 8593A	A - 15		

#### Environmental conditions :

Temperature: 23 °C      Humidity: 54 %

**-20dB Bandwidth Measurement(Sec.15.247(a)(1)(ii))**

**Test Procedure :**

The measurement test-setup is shown in the figure. The modulation is set to page 14.

The setting of the spectrum analyzer are shown as follows :

Res. Bandwidth : 10 kHz  
 Video Bandwidth : 30 kHz  
 Span : 2 MHz  
 Sweep Time : AUTO  
 Trace : Maxhold

**Used test instruments:**

Model No.	Device ID	Last Cal. Date	Cal. Interval
● - 8566B	A - 13	December, 2000	1 Year
● - 4T-10	D - 73	May, 2001	1 Year
● - 4T-10	D - 74	May, 2001	1 Year

**Band-edge Emission Measurement(§15.247(c))**

**Test Procedure :**

The measurement test-setup is shown in the figure. The modulation is set to page 14.

The setting of the spectrum analyzer are shown as follows :

Center Frequency : 2400 MHz / 2483.5 MHz  
 Res. Bandwidth : 100 kHz  
 Video Bandwidth : 300 kHz  
 Span : 2 MHz  
 Sweep Time : AUTO  
 Trace : Maxhold

**Used test instruments:**

Model No.	Device ID	Last Cal. Date	Cal. Interval
● - 8566B	A - 13	December, 2000	1 Year
● - 4T-10	D - 73	May, 2001	1 Year
● - 4T-10	D - 74	May, 2001	1 Year

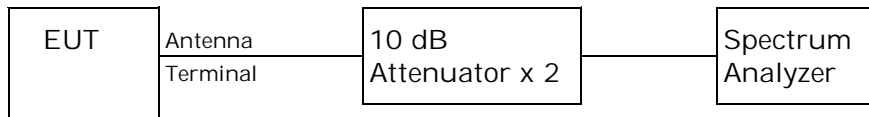

**Environmental conditions:**

Temperature: 23 °C      Humidity: 54 %

**Carrier Frequency Separation Measurement(Sec.15.247(a)(1))**

**Test Procedure :**

The measurement test-setup is shown in the figure. The modulation is set to page 14.  
 The transmitting frequency is set to 2439.936MHz(ch45) or 2440.800MHz(ch46).  
 The setting of the spectrum analyzer are shown as follows :

Center Frequency : 2440.3 MHz  
 Res. Bandwidth : 100 kHz  
 Video Bandwidth : 300 kHz  
 Span : 10 MHz  
 Sweep Time : AUTO  
 Trace : Maxhold

**Used test instruments:**

Model No.	Device ID	Last Cal. Date	Cal. Interval
● - 8566B	A - 13	December, 2000	1 Year
● - 4T-10	D - 73	May, 2001	1 Year
● - 4T-10	D - 74	May, 2001	1 Year

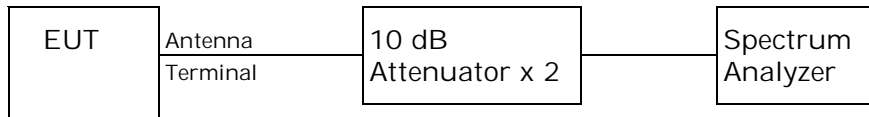

**Environmental conditions:**

Temperature: 23 °C      Humidity: 54 %

**CONFIGURATION OF EUT**

**The Equipment Under Test (EUT) consists of:**

Description	Applicant (Manufacturer)	Model No. (Serial No.)	FCC ID
2.4GHz Cell Station for PBX	Kyushu Matsushita Electric Co., Ltd. (Kyushu Matsushita Electric Co., Ltd.)	KX-TDA0142 (--)	ACJ96NKX-TDA0142

**The measurement was carried out with the following equipment connected:**

Description	Grantee/Distributor	Model No. (Serial No.)	FCC ID
DC Power Supply	KIKUSUI ELECTRONICS CORP.	PAB350-0.2 (1350153)	N/A

**Type of Interference Cable(s) and the AC Power Cord used with the EUT:**

	Description	Port	Shielded Cable	Shell Material	Ferrite Core	Cable Length
1	EUT	Modular	NO	--	NO	2.2 m
	----- DC Power Supply	--		--		
2	AC Power Cord (DC Power Supply) 1φ-2Pin Plug	--	NO	-- ----- --	NO	2.2 m

### **Operation - mode of the EUT:**

The EUT was operated during the test under the following specification:

Transmitting

Modulation signal : TDMA/TDD Burst Type(FSK 164kHz dev.)

For operating condition of the EUT, the typical modulating signal is not used and inputted because the occupied bandwidth of the EUT is subject to restriction due to the bit rate of preamble data other than audio data in the transmitting data .

### **Test system:**

The EUT has one port as one Modular port. The DC40V is supplied through the port.

The EUT has diversity antenna system with 2 antennas. During the test, the transmitting power is connected to one of 2 antennas.

### **Special accessories:**

None

**EUT Modification**

- - No modifications were conducted by JQA to achieve compliance to applied levels.
- - To achieve compliance to applied levels, the following change(s) were made by JQA during the compliance test.

The modification(s) will be implemented in all production models of this equipment.

Applicant :  N/A  Date : N/A  
Typed Name : N/A Position : N/A

**Responsible Party**

Responsible Party of Test Item(Product)

Responsible party :

Contact Person :

\_\_\_\_\_  
Signatory

**Deviation from Standard**

- - No deviations from the standard described in page 3.
- - The following deviations were employed from the standard described in page 3.

\_\_\_\_\_  
\_\_\_\_\_

### TEST RESULTS

#### AC Powerline Conducted Emission 450 kHz - 30 MHz(Sec.15.207(a))

The requirements are  - **Passed**  - **Not Passed**  
Min. limit margin \_\_\_\_\_ dB at \_\_\_\_\_ MHz  
Max. limit exceeding \_\_\_\_\_ dB at \_\_\_\_\_ MHz  
Uncertainty of measurement results \_\_\_\_\_ dB(2 $\sigma$ ) \_\_\_\_\_ dB(2 $\sigma$ )

**Remarks:** Not Applicable

#### Electromagnetic Field Radiated Emission 9 kHz - 25 GHz

##### Maximum Peak Power (EIRP)(Sec.15.247(b)(1))

The requirements are  - **Passed**  - **Not Passed**  
Maximum Peak Power (EIRP) 0.329 W at 2440.800 MHz  
Min. limit margin 4.8 dB at 2440.800 MHz  
Max. limit exceeding \_\_\_\_\_ dB at \_\_\_\_\_ MHz

##### Spurious(Sec.15.247(c),15.205(a),15.209(a))

The requirements are  - **Passed**  - **Not Passed**  
Min. limit margin 7.3 dB at 134.8 MHz  
Max. limit exceeding \_\_\_\_\_ dB at \_\_\_\_\_ MHz  
Uncertainty of measurement results ( $\leq 30$  MHz) + 2.5 dB(2 $\sigma$ ) - 2.5 dB(2 $\sigma$ )  
Uncertainty of measurement results (30 MHz - 1000 MHz) + 4.9 dB(2 $\sigma$ ) - 5.0 dB(2 $\sigma$ )  
Uncertainty of measurement results ( $\geq 1000$  MHz) + 3.1 dB(2 $\sigma$ ) - 3.2 dB(2 $\sigma$ )

**Remarks:** \_\_\_\_\_

**Transmitter Power(TP)(Sec.15.247(b)(1))**

The requirements are	<b>● - Passed</b>	<b>○ - Not Passed</b>
The transmitter power is	<u>0.295</u> W at <u>2401.056</u> MHz	
Min. limit margin	<u>5.3</u> dB at <u>2401.056</u> MHz	
Max. limit exceeding	<u>        </u> dB at <u>        </u> MHz	
Uncertainty of measurement results	<u>+0.6</u> dB(2σ)	<u>-0.6</u> dB(2σ)

**Remarks:** \_\_\_\_\_  
\_\_\_\_\_

**Antenna Gain of the EUT(Sec.15.247(b)(3)(i))**

The antenna gain is 0.97 dBi at 2440.800 MHz

**Remarks:** \_\_\_\_\_  
\_\_\_\_\_

**-20dB Bandwidth(Sec.15.247(a)(1)(ii))**

The requirements are	<b>● - Passed</b>	<b>○ - Not Passed</b>
The -20dB Bandwidth is	<u>604.0</u> kHz at <u>2479.680</u> MHz	
The results	Refer to pages	36 - 38
Min. limit margin	<u>396.0</u> kHz at <u>2479.680</u> MHz	
Max. limit exceeding	<u>        </u> kHz at <u>        </u> MHz	
Uncertainty of measurement results at Frequency	<u>±0.05</u> ppm(2σ)	
Uncertainty of measurement results at Amplitude	<u>±0.6</u> dB(2σ)	

**Remarks:** \_\_\_\_\_  
\_\_\_\_\_

**Band-edge Emission(Sec.15.247(c))**

The requirements are

● - **Passed**      ○ - **Not Passed**

The results

Refer to pages 39 - 40

Uncertainty of measurement results at Frequency  
Uncertainty of measurement results at Amplitude

±0.05 ppm(2σ)  
±0.6 dB(2σ)

**Remarks:** \_\_\_\_\_  
\_\_\_\_\_

**Carrier Frequency Separation(Sec.15.247(a)(1))**

The requirements are

● - **Passed**      ○ - **Not Passed**

Channel Separation

860 kHz

The results

Refer to page 42

Uncertainty of measurement results at Frequency  
Uncertainty of measurement results at Amplitude

±0.05 ppm(2σ)  
±0.6 dB(2σ)

**Remarks:** \_\_\_\_\_  
\_\_\_\_\_

## SUMMARY

### GENERAL REMARKS :

The EUT was tested according to the requirements of FCC Rules and Regulations Part 15 Subpart A and C (February 28, 2001) under the test configuration, as shown in page 20.

The conclusion for the test items of which are required by the applied regulation is indicated under the final judgement.

### FINAL JUDGEMENT :

The "as received" sample;

- - fulfill the test requirements of the regulation mentioned on page 3.
- - fulfill the test requirements of the regulation mentioned on page 3, but with certain qualifications.
- - doesn't fulfill the test regulation mentioned on page 3.

Begin of testing : September 29, 2001

End of testing : October 1, 2001

- JAPAN QUALITY ASSURANCE ORGANIZATION -

Approved by :



\_\_\_\_\_  
Akio Hosoda  
Manager  
EMC Div.  
JQA KITA-KANSAI Testing Center

Issued by :



\_\_\_\_\_  
Shigeru Kinoshita  
Deputy Manager  
EMC Div.  
JQA KITA-KANSAI Testing Center

**Test System-Arrangement (Drawings)**

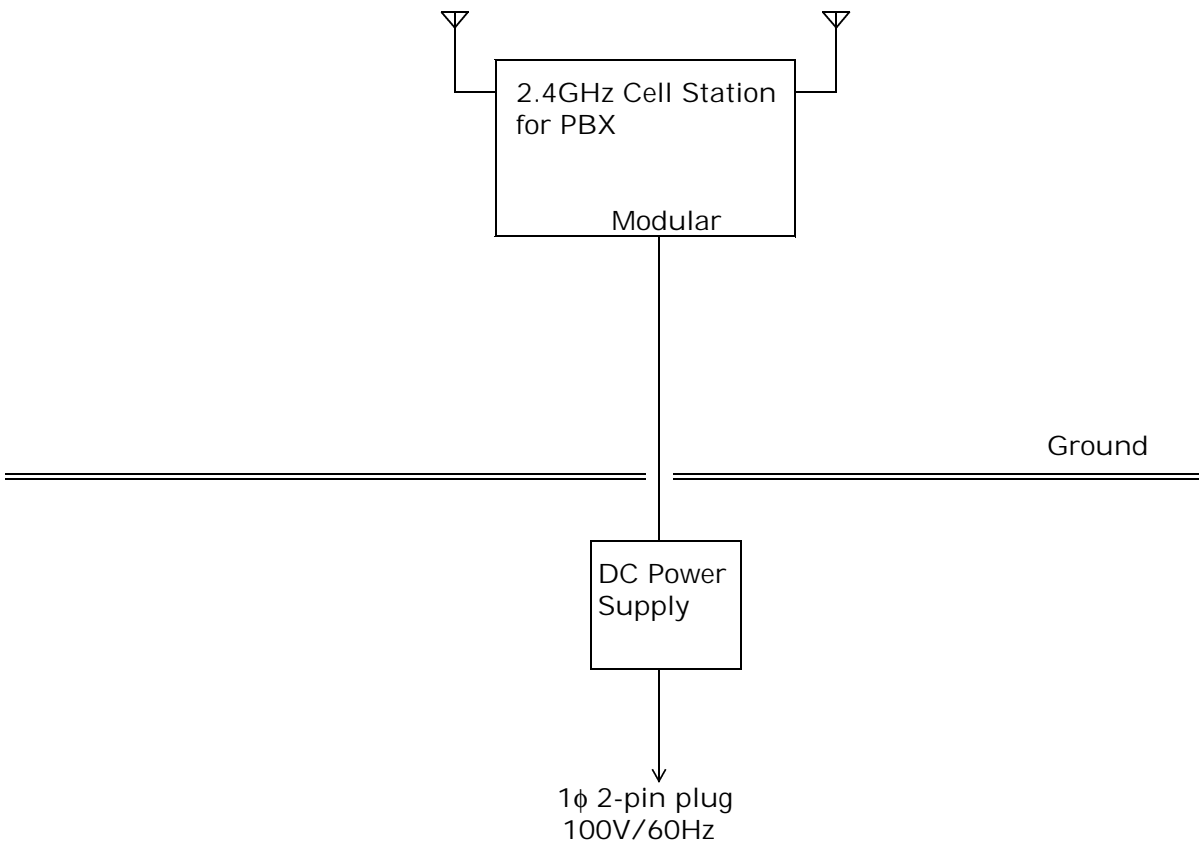

### **Preliminary Test and Test-setup(Drawings)**

#### Radiated Emission (Magnetic Field) 9 kHz - 30 MHz:

The preliminary test was performed according to the description of ANSI C63.4-1992 Sec.8.3.1.1 (Preliminary Radiated Emissions Tests) and Sec.6.2.1 (Tabletop Equipment Tests).

The preliminary test was carried out to investigate the frequency of the emission that has the highest amplitude relative to the limits within normal operating modes, cable positions, and a typical system configuration. In order to find out to the maximum emission, the preliminary test and a final test were performed in accordance with the following steps.

Step 1: One operation mode of the test system was setting.

Step 2: In order to investigate the frequencies of maximum emissions, the loop antenna position was approached to the EUT and the significant frequency of the emission's circumstance from the test system were investigated. These data were recorded in the specified frequency band (9 kHz - 30 MHz).

Step 3: Using a test receiver and a loop antenna, the emission's circumstance from the test system was measured in according with ANSI C63.4-1992 Sec.8.3.1.2 (Final Radiated Emissions Tests) at each frequency which was found the higher emission referred to level vs. frequency on the list and which was measured by the loop antenna. The maximum emission was found by changing the antenna angle under a typical system configuration.

Step 4: Return to step 1, if the other operation mode was possible to be setting.

Step 5: The worst result was reported arranging data of which was obtained and performed by one or plural operation modes as the final test.

At the worst point that has the highest amplitude relative to the limit the repeatability of the level was reconfirmed. The photographs of the tests system setup on the worst point were taken and recorded.

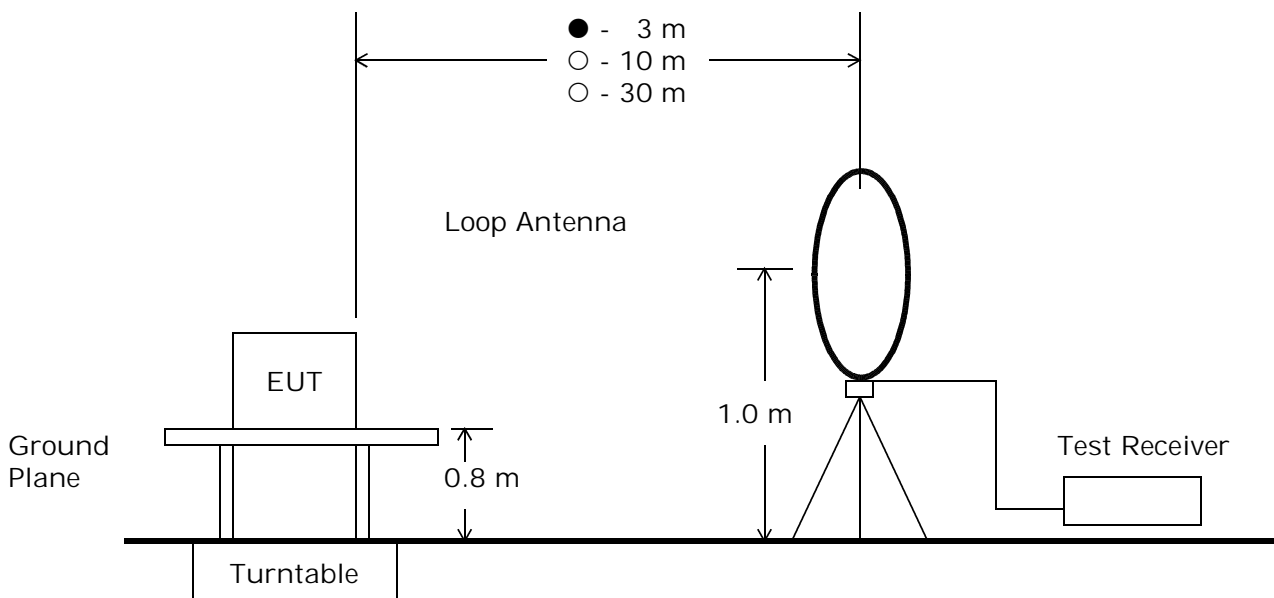

Electromagnetic Field Radiated Emission 30 MHz - 1000 MHz:

The preliminary test was performed according to the description of ANSI C63.4-1992 Sec.8.3.1.1 (Preliminary Radiated Emissions Tests) and Sec.6.2.1 (Tabletop Equipment Tests).

The preliminary test was carried out to investigate the frequency of the emission that has the highest amplitude relative to the limits within normal operating modes, cable positions, and a typical system configuration. In order to find out to the maximum emission, the preliminary test and a final test were performed in accordance with the following steps.

Step 1: One operation mode of the test system was setting.

Step 2: Using a test receiver and a test antenna probe, the significant frequency of the emission's circumstance from the test system were investigated. These data were recorded every one of 22 divided bands in the specified frequency band (30 MHz - 1000 MHz).

Step 3: Using a test receiver and a resonant tuned dipole antenna, the emission's circumstance from the test system was measured in according with ANSI C63.4-1992 Sec.8.3.1.2 (Final Radiated Emissions Tests) at each frequency which was found the higher emission referred to level vs. frequency on the list and which was measured by the resonant tuned dipole antenna. The maximum emission was found by changing the antenna angle under a typical system configuration.

Step 4: Return to step 1, if the other operation mode was possible to be setting.

Step 5: The worst result was reported arranging data of which was obtained and performed by one or plural operation modes as the final test.

At the worst point that has the highest amplitude relative to the limit the repeatability of the level was reconfirmed. The photographs of the tests system setup on the worst point were taken and recorded.

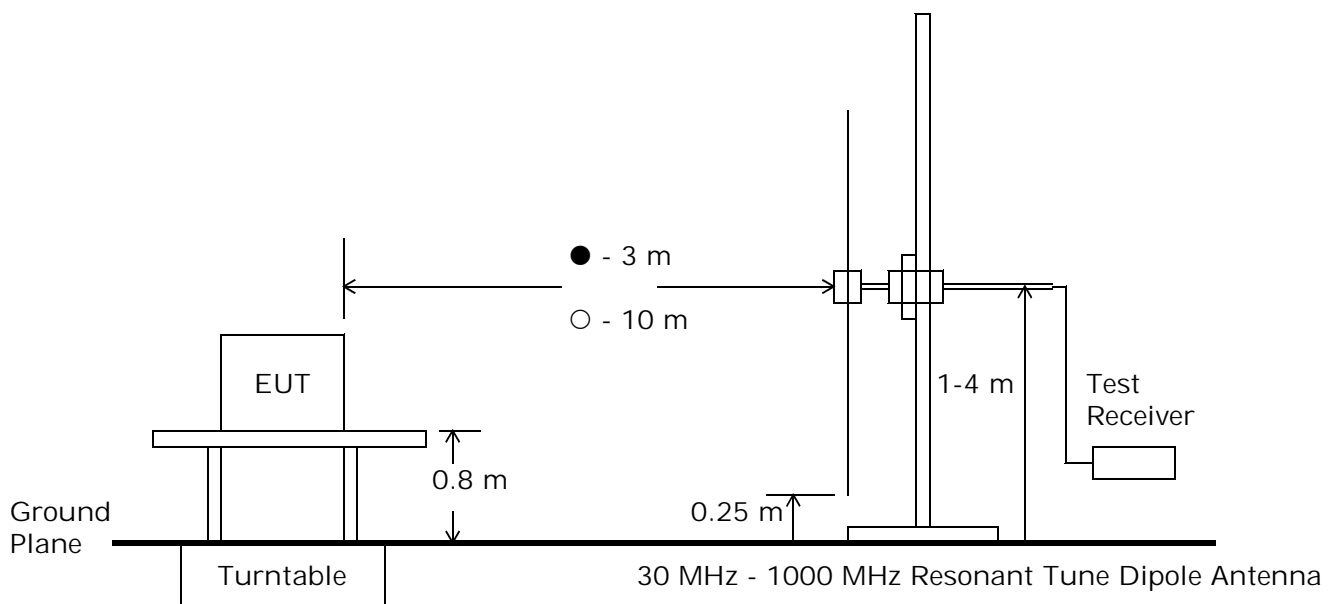

Electromagnetic Field Radiated Emission 1 GHz - 25 GHz:

The preliminary test was performed according to the description of ANSI C63.4-1992 Sec.8.3.1.1 (Preliminary Radiated Emissions Tests) and Sec.6.2.1 (Tabletop Equipment Tests).

The preliminary test was carried out to investigate the frequency of the emission that has the highest amplitude relative to the limits within normal operating modes, cable positions, and a typical system configuration. In order to find out to the maximum emission, the preliminary test and a final test were performed in accordance with the following steps.

Step 1: One operation mode of the test system was setting.

Step 2: In order to investigate the frequencies of maximum emissions, the horn antenna position was approached to the EUT and the significant frequency of the emission's circumstance from the test system were investigated. These data were recorded in the specified frequency band (1 GHz - 25 GHz).

Step 3: The emission's circumstance from the test system was measured in accordance with ANSI C63.4-1992, Sec.8.3.1.2 (Final Radiated Emissions Tests) at each frequency which was found higher emission referred to level vs. frequency on the list and which was measured in the specified distance using the horn antenna. The maximum emission was found by changing the antenna angle under a typical system configuration.

Step 4: Return to step 1, if the other operation mode was possible to be setting.

Step 5: The worst result was reported arranging data of which was obtained and performed by one or plural operation modes as the final test.

At the worst point that has the highest amplitude relative to the limit the repeatability of the level was reconfirmed. The photographs of the tests system setup on the worst point were taken and recorded.

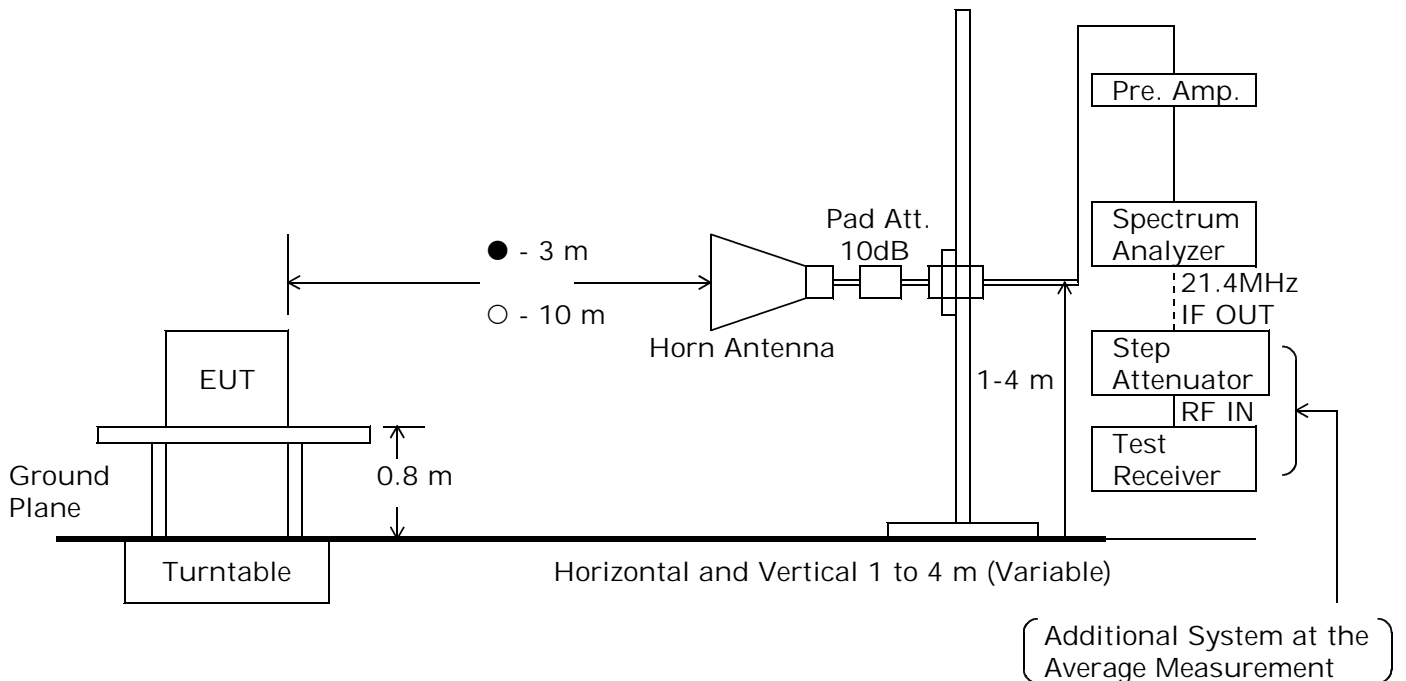

Spectrum Analyzer Setting:

Detector	*)Peak/Average
RES BW	1 MHz
VIDEO BW	1 MHz
SPAN	0 Hz

Test Receiver Setting:

SCALE	LINEAR	LINEAR
I.F.B.W.	1 MHz	1 MHz
Detector	Average	Peak

\*) For the average measurement, it is made using a test receiver and a step attenuator.

**Test-Setup (Photographs) at worst case**

Conducted Emission 450kHz - 30MHz:

Not Applicable

Radiated Emission 9 kHz - 25 GHz



Horizontal polarization



Vertical polarization

## Electromagnetic Field Radiated Emission Measurement

Intentional Radiator

Spurious emission except fundamental and harmonics(9kHz - 1GHz)

Test Date: September 29, 2001

Temp.: 23 °C ; Humi.: 62 %

**Transmitting Frequency : 2440.800 MHz (46 ch)**

Frequency [MHz]	Antenna Factor [dB(1/m)]	Cable Loss [dB]	Meter Readings [dB(μV)]		Limits [dB(μV/m)]	Results [dB(μV/m)]		Margin [dB]	Remarks (Note 2)
			Hori.	Vert.		Hori.	Vert.		
31.1	-0.6	0.5	< 20.0	25.0	40.0	< 19.9	24.9	+15.1	C
62.2	4.8	0.8	< 20.0	< 20.0	40.0	< 25.6	< 25.6	> +14.4	C
72.6	6.1	0.8	< 17.0	< 16.0	40.0	< 23.9	< 22.9	> +16.1	C
82.9	7.3	0.9	< 12.0	19.0	40.0	< 20.2	27.2	+12.8	C
103.7	9.2	1.0	8.0	12.0	43.5	18.2	22.2	+21.3	C
124.2	10.8	1.1	11.0	10.0	43.5	22.9	21.9	+20.6	C
165.9	13.3	1.3	10.0	9.0	43.5	24.6	23.6	+18.9	C
259.2	17.2	1.7	10.0	8.0	46.0	28.9	26.9	+17.1	C
300.7	18.4	1.8	10.0	10.0	46.0	30.2	30.2	+15.8	C
373.3	20.5	2.1	12.0	10.0	46.0	34.6	32.6	+11.4	C

Sample of calculated result at 373.3 MHz, as the Minimum Margin point:

Antenna Factor	=	20.5 dB(1/m)
+ Cable Loss	=	2.1 dB
Meter Reading	=	12.0 dB(μV)
Result	=	34.6 dB(μV/m)

Minimum Margin : 46.0 - 34.6 = 11.4(dB)

The point shown on " \_\_\_\_ " is the Minimum Margin Point.

Note 1:

- 1)The highest frequency generated or used in the EUT: 2479.680 MHz
- 2)The upper frequency of measurement range : 25 GHz
- 3)The spectrum was scanned 9 kHz to 1 GHz and all emissions not reported were more than 20 dB below the applied limits.

**Remarks:**

Note 2	Detector Function	IF Bandwidth
A	CISPR QP	200 Hz
B	CISPR QP	9 kHz
C	CISPR QP	120 kHz
D	Average	120 kHz
E	Average	12 kHz
F	Average	7.5 kHz

**Electromagnetic Field Radiated Emission Measurement**  
 Intentional Radiator  
 Fundamental and Spurious(above 1 GHz )

Test Date: September 30, 2001  
 Temp.: 28 °C ; Humi.: 58 %

**Transmitting Frequency : 2401.056 MHz (00ch)**

Frequency [MHz]	Antenna Factor [dB(1/m)]	Cable Loss [dB]	Meter Readings at 3m [dB(μV)]		Limits [dB(μV/m)]	Results at 3m [dB(μV/m)]		Margin [dB]	Remarks (Note 2)
			Hori.	Vert.		Hori.	Vert.		
<b>Fundamental</b> 2401.056	21.6	0.3	101.5	98.6	---	123.4	120.5	---	B
<b>Spurious at Peak Detector</b>									
* 4802.112	27.3	-31.2	55.5	53.0	74.0	51.6	49.1	+22.4	D
7203.168	29.9	-29.5	49.5	50.5	103.4	49.9	50.9	+52.5	B
9604.224	33.4	-27.5	45.0	48.5	103.4	50.9	54.4	+49.0	B
* 12005.280	33.6	-26.7	47.0	49.0	74.0	53.9	55.9	+18.1	D
14406.336	37.1	-26.3	< 43.0	< 43.0	103.4	< 53.8	< 53.8	> +49.6	B
16807.392	37.2	-27.0	< 43.0	< 43.0	103.4	< 53.2	< 53.2	> +50.2	D
* 19208.448	40.2	-28.6	< 43.0	< 43.0	74.0	< 54.6	< 54.6	> +19.4	B
21609.504	40.3	-28.1	< 43.0	< 43.0	103.4	< 55.2	< 55.2	> +48.2	B
24010.560	40.4	-28.7	< 43.0	< 43.0	103.4	< 54.7	< 54.7	> +48.7	B
<b>Spurious at Average Detector</b>									
* 4802.112	27.3	-31.2	33.0	31.0	54.0	29.1	27.1	+24.9	C
* 12005.280	33.6	-26.7	28.0	29.0	54.0	34.9	35.9	+18.1	C
* 19208.448	40.2	-28.6	< 30.0	< 30.0	54.0	< 41.6	< 41.6	> +12.4	C

**Transmitting Frequency : 2440.800 MHz (46ch)**

Frequency [MHz]	Antenna Factor [dB(1/m)]	Cable Loss [dB]	Meter Readings at 3m [dB(μV)]		Limits [dB(μV/m)]	Results at 3m [dB(μV/m)]		Margin [dB]	Remarks (Note 2)
			Hori.	Vert.		Hori.	Vert.		
<b>Fundamental</b>									
2440.800	21.6	0.3	101.0	99.0	---	122.9	120.9	---	B
<b>Spurious at Peak Detector</b>									
* 4881.600	27.3	-31.2	56.5	54.0	74.0	52.6	50.1	+21.4	D
* 7322.400	29.9	-29.4	46.0	47.0	74.0	46.5	47.5	+26.5	D
9763.200	33.5	-27.4	< 40.0	44.5	102.9	< 46.1	50.6	+52.3	B
* 12204.000	33.6	-26.6	48.5	50.0	74.0	55.5	57.0	+17.0	D
14644.800	37.1	-26.5	< 43.0	< 43.0	102.9	< 53.6	< 53.6	> +49.3	B
17085.600	37.2	-27.1	< 43.0	< 43.0	102.9	< 53.1	< 53.1	> +49.8	B
* 19526.400	40.3	-28.2	< 43.0	< 43.0	74.0	< 55.1	< 55.1	> +18.9	D
21967.200	40.3	-28.4	< 43.0	< 43.0	102.9	< 54.9	< 54.9	> +48.0	B
24408.000	40.4	-28.7	< 43.0	< 43.0	102.9	< 54.7	< 54.7	> +48.2	B
<b>Spurious at Average Detector</b>									
* 4881.600	27.3	-31.2	32.0	31.0	54.0	28.1	27.1	+25.9	C
* 7322.400	29.9	-29.4	27.5	28.0	54.0	28.0	28.5	+25.5	C
* 12204.000	33.6	-26.6	28.5	29.0	54.0	35.5	36.0	+18.0	C
* 19526.400	40.3	-28.2	< 30.0	< 30.0	54.0	< 42.1	< 42.1	> +11.9	C

**Transmitting Frequency : 2479.680 MHz (91ch)**

Frequency [MHz]	Antenna Factor [dB(1/m)]	Cable Loss [dB]	Meter Readings at 3m [dB(μV)]		Limits [dB(μV/m)]	Results at 3m [dB(μV/m)]		Margin [dB]	Remarks (Note 2)
			Hori.	Vert.		Hori.	Vert.		
<b>Fundamental</b>									
2479.680	21.4	0.3	100.5	99.0	---	122.2	120.7	---	B
<b>Spurious at Peak Detector</b>									
* 4959.360	27.3	-31.2	56.0	51.0	74.0	52.1	47.1	+21.9	D
* 7439.040	30.0	-29.2	49.5	50.0	74.0	50.3	50.8	+23.2	D
9918.720	33.4	-27.6	< 40.0	< 40.0	102.2	< 45.8	< 45.8	> +56.4	B
* 12398.400	33.6	-26.6	48.5	50.0	74.0	55.5	57.0	+17.0	D
14878.080	37.1	-26.6	< 43.0	< 43.0	102.2	< 53.5	< 53.5	> +48.7	B
17357.760	37.2	-27.0	< 43.0	< 43.0	102.2	< 53.2	< 53.2	> +49.0	B
* 19837.440	40.3	-28.0	< 43.0	< 43.0	74.0	< 55.3	< 55.3	> +18.7	D
* 22317.120	40.4	-28.0	< 43.0	< 43.0	102.2	< 55.4	< 55.4	> +46.8	D
24796.800	40.4	-29.2	< 43.0	< 43.0	102.2	< 54.2	< 54.2	> +48.0	B
<b>Spurious at Average Detector</b>									
* 4959.360	27.3	-31.2	34.5	31.5	54.0	30.6	27.6	+23.4	C
* 7439.040	30.0	-29.2	30.5	31.0	54.0	31.3	31.8	+22.2	C
* 12398.400	33.6	-26.6	28.5	29.0	54.0	35.5	36.0	+18.0	C
* 19837.440	40.3	-28.0	< 30.0	< 30.0	54.0	< 42.3	< 42.3	> +11.7	C
* 22317.120	40.4	-28.0	< 30.0	< 30.0	54.0	< 42.4	< 42.4	> +11.6	C

Sample of calculated result at 22317.120 MHz, as the Minimum Margin point:

Antenna Factor = 40.4 dB(1/m)  
 Corr. Factor = -28.0 dB  
 +) Meter Reading = <30.0 dB(μV)  
 Result = <46.8 dB(μV/m)

Minimum Margin : 54.0 - <42.4 = >11.6(dB)

The point shown on " \_\_\_ " is the Minimum Margin Point.

Note 1:

- 1)The highest frequency generated or used in the EUT: 2479.680 MHz
- 2)The upper frequency of measurement range : 25 GHz
- 3)The spectrum was scanned 1 GHz to 25 GHz and all emissions not reported were more than 20 dB below the applied limits.
- 4)Symbol '\*\*' : Restricted bands of operation in Sec.15.205.
- 5)Corr. Factor [dB] (below 1 GHz) = Cable Loss [dB]  
 Corr. Factor (Fundamental) = Cable Loss [dB]  
 Corr. Factor (≤ 18 GHz except Fundamental) = Cable Loss + 10 dB Pad Attenuator - Amp. Gain [dB]  
 Corr. Factor (≥ 18 GHz) = Cable Loss - Amp. Gain + Mixer Conversion Loss(at IF=8GHz)[dB]

**Remarks:**

Note 2	Detector Function	RES. B.W	V.B.W	Sweep T	Span
A	Peak (SP)	1 MHz	1 MHz	20 msec	0 Hz
B	Peak (SP)	100 kHz	300 kHz	20 msec	0 Hz
*) C	Average (Receiver)	1 MHz (1 MHz)	3 MHz	20 msec	0 Hz
D	Peak	1 MHz	3 MHz	20 msec	0 Hz

( ):Setting of spectrum analyzer

\*)For the average/peak measurement method, it is made measurement using a test receiver, a step attenuator or and a spectrum analyzer(FCC REPLY No. 950523A).

Tester : Akio Hosoda

### Maximum Peak Power (EIRP) Measurement Fundamental Emission

Test Date: September 30, 2001  
 Temp.: 28 °C ; Humi.: 58 %

Measurement Results:

**Radiated Emission Measurement at 3m**

Frequency [MHz] Fundamental	Antenna Factor [dB(1/m)]	Cable Loss [dB]	Meter Readings at 3m [dB(μV)]		Results at 3m [dB(μV/m)]		Remarks (Note 1)
			Hori.	Vert.	Hori.	Vert.	
2401.056	21.6	0.3	101.5	98.6	123.4	120.5	A
2440.800	21.6	0.3	101.0	99.0	122.9	120.9	A
2479.680	21.4	0.3	100.5	99.0	122.2	120.7	A

**Remarks:**

Note 1	Detector Function	RES. B.W	V.B.W	Sweep T	Span
A	Peak	1 MHz	3 MHz	20 msec	0 Hz

Calculated Results:

CH No.	Frequency (MHz)	Maximum Peak Power EIRP(W)		Limits (W)	Margin (dB)
		Hori.	Vert.		
00	2401.056	0.656	0.337	1.000	+1.8
46	2440.800	0.585	0.369	1.000	+2.3
91	2479.680	0.498	0.352	1.000	+3.0

The EUT is placed at 3m away from the receiving antenna and the EIRP is calculated using the following formula:

$$E^2 / (120\pi) = \text{EIRP} / (4\pi d^2) \quad \text{where} \quad \text{EIRP} = P_h G_h, \quad E : \text{Field Strength at } d \text{ (distance) m} [\mu\text{V/m}]$$

$$\text{EIRP} = (dE)^2 / 30 \quad G_h = \text{Substituted Antenna [dBi]}$$

$$\text{EIRP(W)} = (3 \times E(\mu\text{V/m}) \times 10^{-6})^2 / 30 \quad P_h = \text{Input power at the Substituted Antenna [W]}$$

The point shown on "\_\_\_" is the Minimum Margin Point.  
 Minimum Margin Point, as 2401.056 MHz :  $10\log(1.000 / 0.656) = 1.8 \text{ (dB)}$

Tester : Akio Hosoda

### Transmitter Power(TP) Measurement

Test Date: October 1, 2001  
 Temp.: 23 °C ; Humi.: 54 %

Measurement Results:

CH No.	Frequency (MHz)	Corr. Factor (dB)	Meter Reading (dBm)	Result (dBm)	Result (W)	Limits (W)	Margin (dB)	Remarks (Note 1)
00	2401.056	10.3	13.1	23.4	0.219	1.000	+6.6	A
46	2440.800	10.3	12.8	23.1	0.204	1.000	+6.9	A
91	2479.680	10.3	12.4	22.7	0.186	1.000	+7.3	A

Sample of calculated result at 2401.056 MHz, as the Minimum Margin point:

$$\begin{aligned} &\text{Correction Factor} = 10.3 \text{ dB} \\ &+) \text{ Meter Reading} = 13.1 \text{ dBm} \\ &\text{Result} = 23.4 \text{ dBm} \quad ; 10^{(23.4/10)} = 0.219 \text{ (W)} \end{aligned}$$

Minimum Margin : 30.0 - 23.4 = 6.6(dB)

The point shown on "\_\_\_" is the Minimum Margin Point.

Note : 1. The correction factor includes the attenuator loss and the cable loss.

**Remarks:**

Note 2	Detector Function	RES. B.W	V.B.W	Sweep T	Span
A	Peak	1 MHz	3 MHz	20 msec	0 Hz

Tester : Shigeru Kinoshita

### Calculated Antenna gain of the EUT

Calculated Results:

Antenna gain of the integrated antenna of the EUT : Geut(dB)  
 Transmitter power (Measured) : TP(dBm)  
 EIRP (Measured) : EIRP(dBm)

If the antenna gain(Geut) is met the equations as follows.

$$\begin{aligned} \text{EIRP} &= \text{TP} * \text{Geut} \\ \text{Geut(Numric)} &= \text{EIRP} / \text{TP} \\ \text{Geut(dB)} &= 10\log_{10}(\text{EIRP} / \text{TP}) \end{aligned}$$

<b>CH No.</b>	<b>Frequency (MHz)</b>	<b>EIRP (W)</b>	<b>TP (W)</b>	<b>Geut (dBi)</b>
00	2401.056	0.656	0.219	4.77
46	2440.800	0.585	0.204	4.57
91	2479.680	0.498	0.186	4.27

Sample of calculated result at 2401.056 MHz, as the Maximum point:

$$\begin{array}{rcl} \text{EIRP} & = & 28.17 \text{ dBm} = 10\log_{10}(0.656) + 30 \\ -) \text{TP} & = & 23.40 \text{ dBm} = 10\log_{10}(0.219) + 30 \\ \hline \text{Result} & = & 4.77 \text{ dBi} \end{array}$$

The point shown on " \_\_\_ " is the Maximum Point.

**-20dB bandwidth and Band-edge Emission Measurement**  
Fundamental Emission

Test Date: October 1, 2001  
Temp.: 23 °C ; Humi.: 54 %

1) -20dB bandwidth measurement  
Measurement Results:

<b>CH No.</b>	<b>Frequency (MHz)</b>	<b>-20dB bandwidth (kHz)</b>	<b>Attached graph page</b>
00	2401.056	614	page 34
46	2440.800	616	page 35
91	2479.680	630	page 36

The point shown on "\_\_\_" is the Maximum Point.

2) Band-edge Emission measurement  
Measurement Results:

<b>CH No.</b>	<b>Frequency (MHz)</b>	<b>Band-edge Frequency (MHz)</b>	<b>Attached graph page</b>
00	2401.056	2400.000	page 37
91	2479.680	2483.500	page 38

Tester : Shigeru Kinoshita

**-20dB Bandwidth Measurement**

**Transmitting Frequency : 2401.056 MHz (00 ch)**

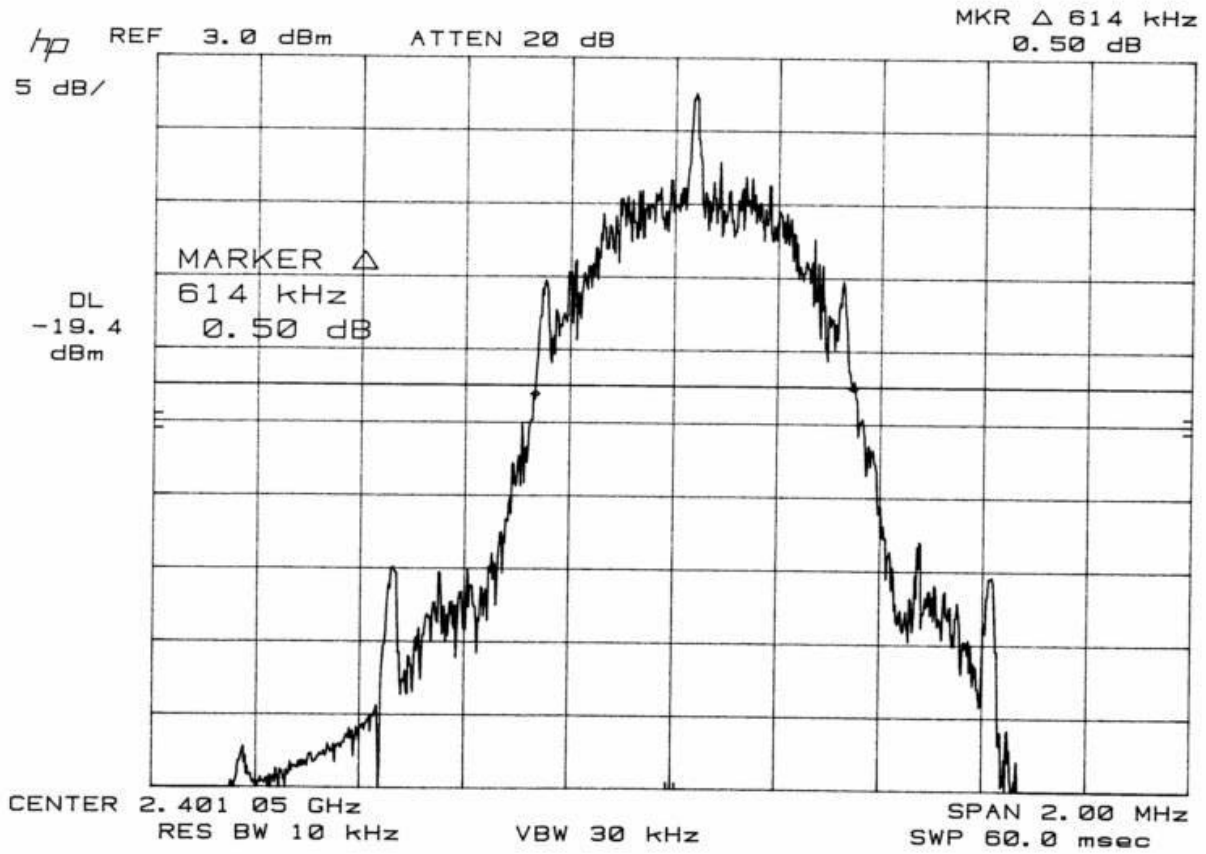

**-20dB Bandwidth Measurement**

**Transmitting Frequency : 2440.800 MHz (46 ch)**

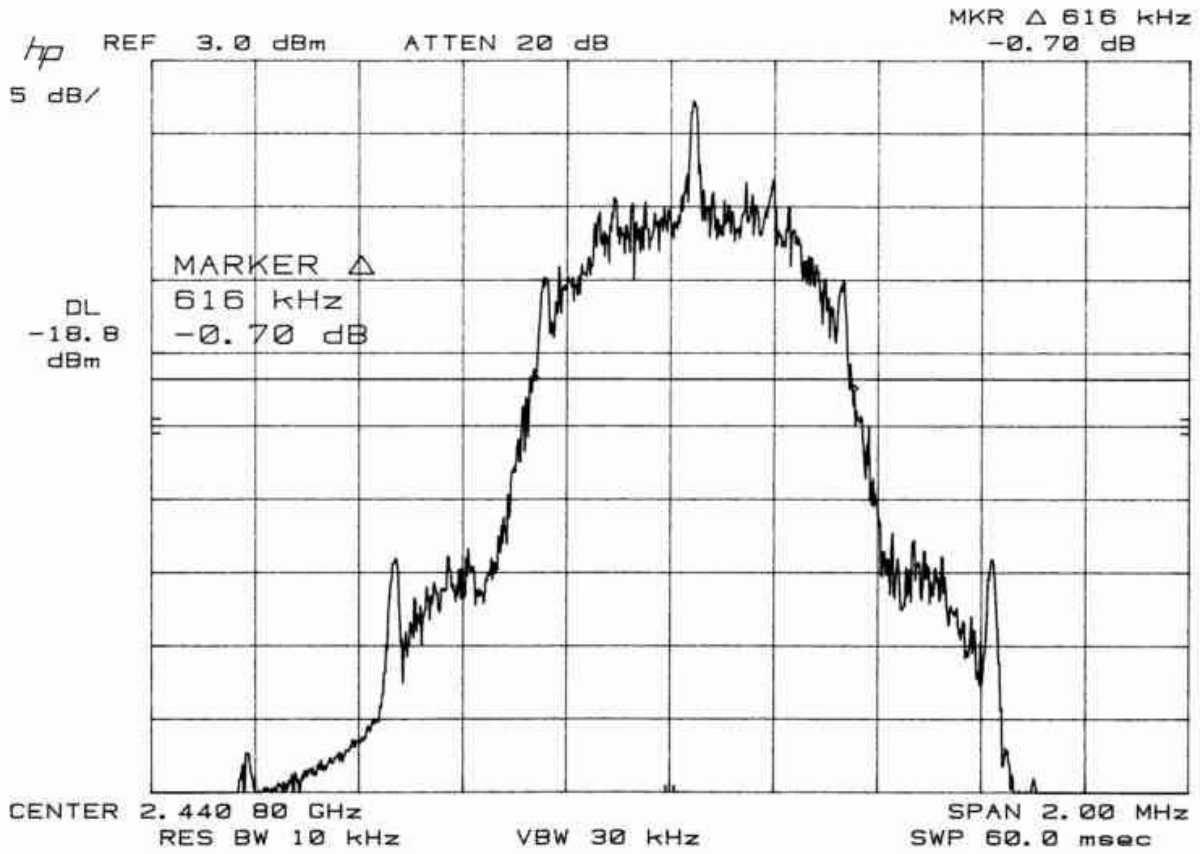

**-20dB Bandwidth Measurement**

**Transmitting Frequency : 2479.680 MHz (91 ch)**

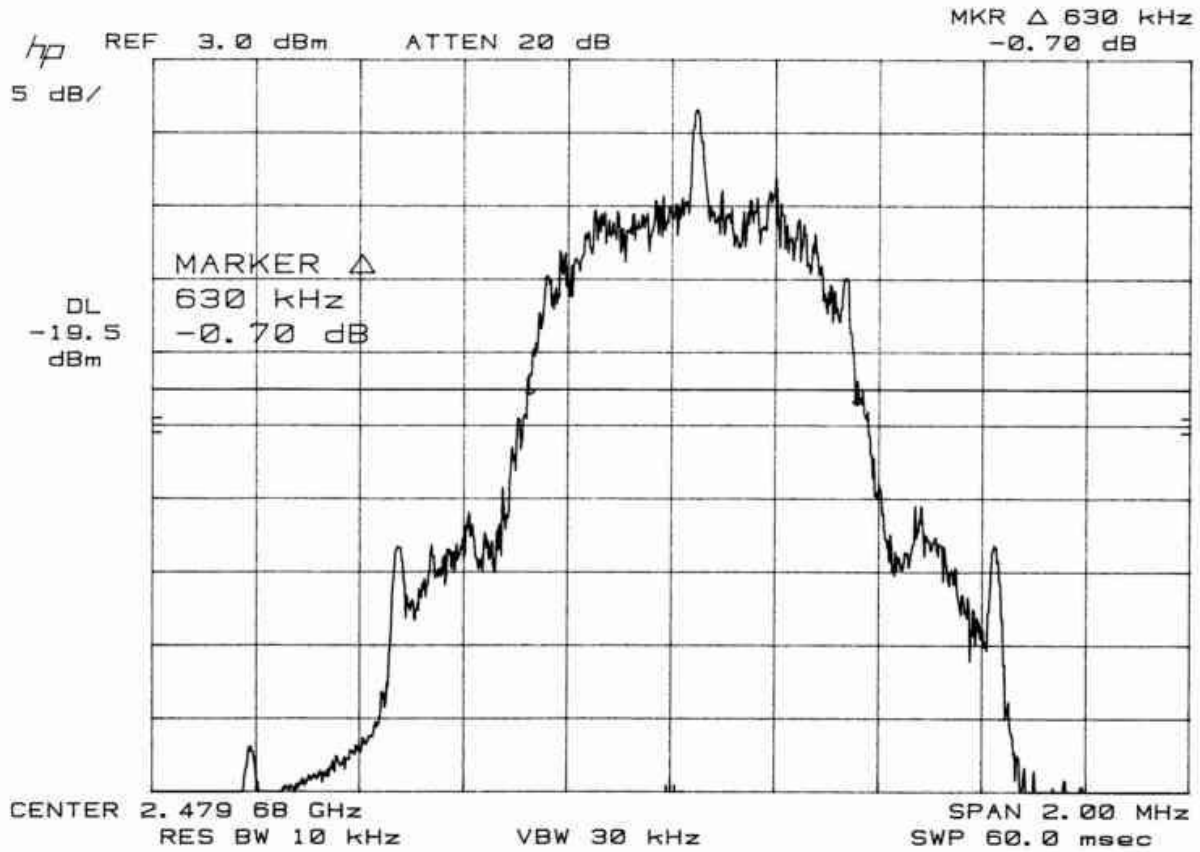

**Band-edge Emission Measurement**

Transmitting Frequency : 2401.056 MHz (00 ch)

Band-edge Frequency : 2400.000 MHz

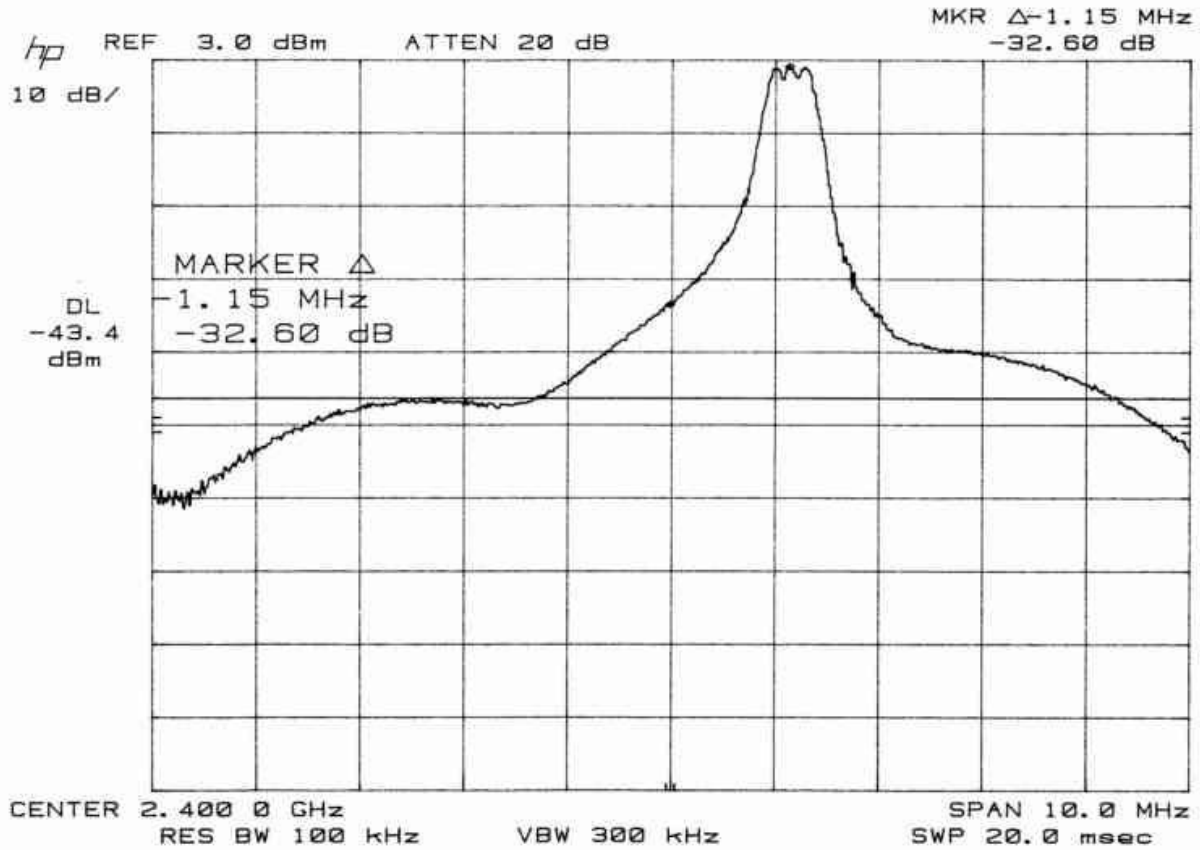

**Band-edge Emission Measurement**

Transmitting Frequency : 2479.680 MHz (91 ch)

Band-edge Frequency : 2483.500 MHz

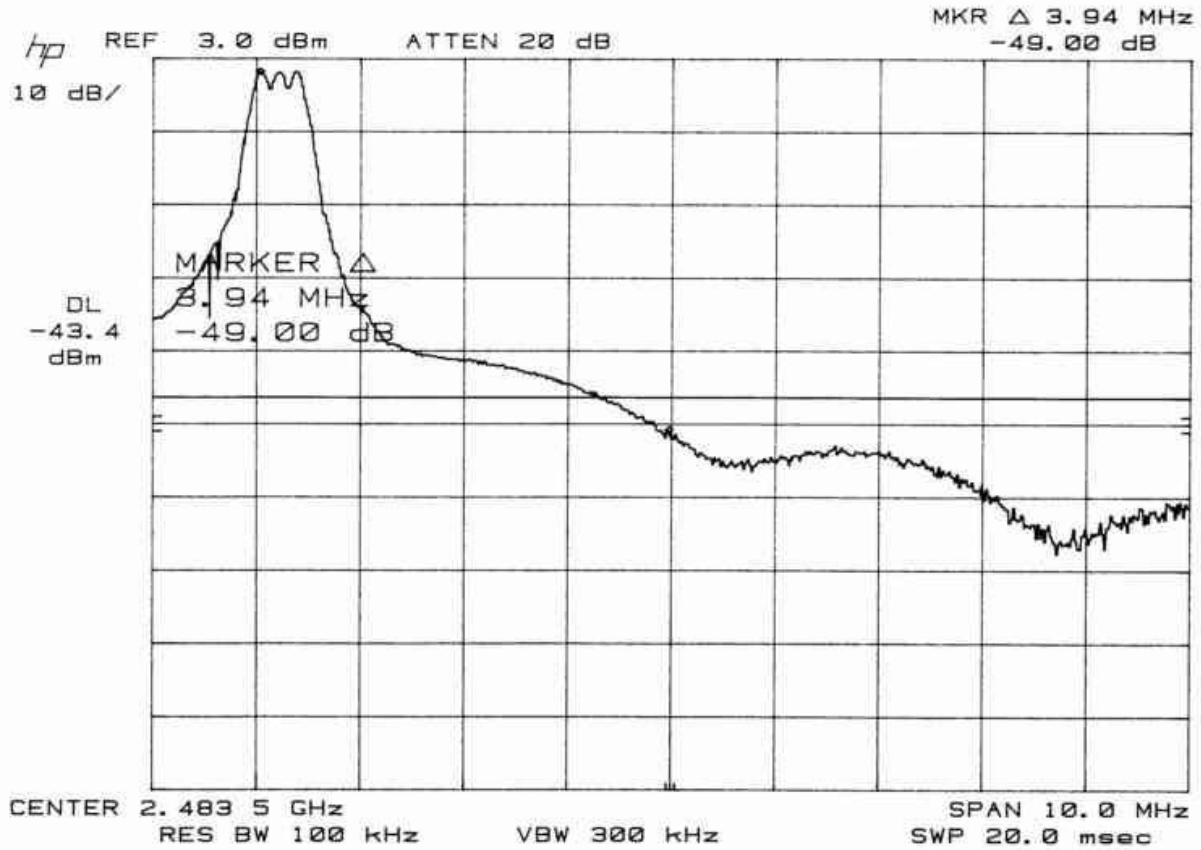

JQA Application No. : KL80010362  
Model No. : KX-TDA0142  
FCC ID : ACJ96NKX-TDA0142

Regulation : CFR 47 FCC Rules Part 15  
Issue Date : October 3, 2001

---

Page 39 of 42

## Carrier Frequency Separation Measurement Fundamental Emission

Test Date: October 1, 2001  
Temp.: 23 °C ; Humi.: 54 %

### Measurement Results:

Transmitting Frequency No.1 : 2439.936 MHz (45 ch)  
Transmitting Frequency No.2 : 2440.800 MHz (46 ch)  
Channel Separation : 860 kHz  
Attached Graph Page : page 40

Tester : Shigeru Kinoshita

**Carrier Frequency Separation Measurement**

Transmitting Frequency No.1 : 2439.936 MHz (45 ch)  
Transmitting Frequency No.2 : 2440.800 MHz (46 ch)

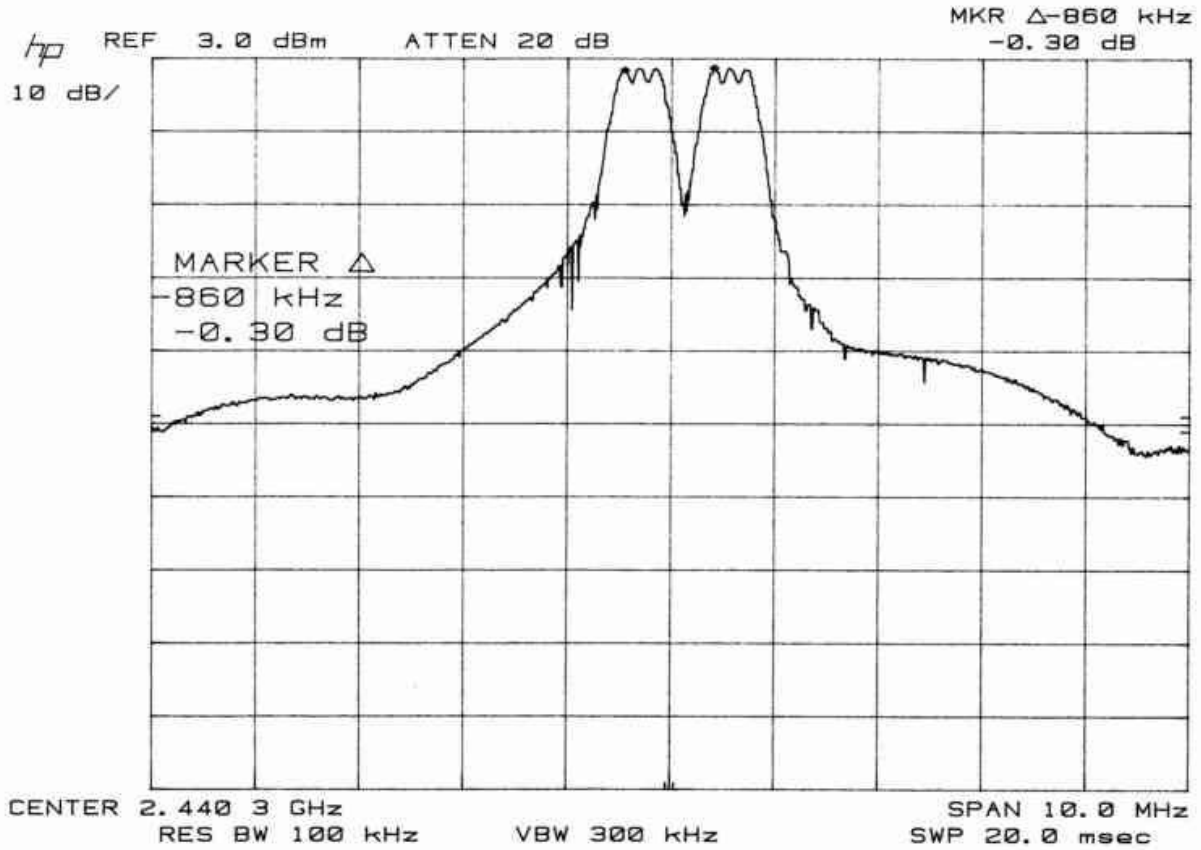

## Sec.247(a)(1)(ii) CHANNEL SEPARATION/DWELL TIME

Compliance with other provision of Sec.15.247 is stated in Kyushu Matsushita Electric Co., Ltd. , as stated below:

Hopping channel carrier frequencies are separated by 864 kHz(Specification).

Each bearer is independent and hops at a rate 100 hops/sec.

The hopping sequence is either table-generated or RNG-generated:

1. A table-generated hop sequence is 75 hops long, each channel is used exactly once in the sequence. Therefore, in a 30 second period each frequency channel is used 40 times in that sequence.
2. An RNG-generated hop sequence is 3000 hops long, each channel is exactly 40 times in the entire sequence. Therefore, in 30 second period each frequency channel is used exactly 40 times in that sequence.

The hopping sequence contains 50 logical channels these are mapped-onto 75 physical channels a mapping table.

The highest channel occupancy, is a FP has 4 traffic bearers(i.e. 8 slots utilized), each using the same hopping sequence. As shown previously, for a given sequence, in a 30 second period each frequency channel is exactly 40 times. A slot of 833μsec long, therefore the average time of occupancy on any frequency channel in a 30 second period is :

$$T = 833 \mu\text{sec} \times 40 \times 8 = 267 \text{ msec}$$

As comparison, the lowest channel occupancy is when only a single dummy bearer is being transmitted. Because only the 'A-field' is used on a dummy bearer, the transmission is 167μsec long, therefore the average time of occupancy on any frequency channel in a 30 second period is:

$$T = 167 \mu\text{sec} \times 40 \times 1 = 6.68 \text{ msec}$$

### Sec.15.247(g)

In the case of the dummy bearer (which the FP transmitter all the time it is powered up and operating), the hopping sequence cycles through the 75 hops in the selected hopping pattern and the repeats.

In the case of a traffic bearer presented with continuous data (which is the normal case, as this is a voice system), the hopping sequence cycles through the 75 hops in the selected pattern and the repeats.

In the case of a traffic bearer transmitting short bursts(for example, which may happen if a PP has several failed attempts<sup>1</sup> to establish a traffic bearer), then the successive traffic bearers will start on different patterns(because the PSTN is incremented each frame.)

Note, that this system is a voice system and short burst transmissions are not typical.

<sup>1</sup> The protocol actually limits the number of re-tries to 11 before giving up on the connection.

### Sec.15.247(h)

There is no coordination between transmitters for the purpose of the avoid the simultaneous occupancy of hopping frequencies by multiple transmitters.

Communication only ever takes place between an FP and a PP, never between two FPs or two PPs. (It is actually impossible for a FP to receive a FP packet or a PP packet, because their respective 'sync-fields' are different).

A FP and a PP that have an active traffic bearer between them, will share a common hopping sequence and hop sequence adaption information (i.e. 'swapped channels'). However, neither the FP nor the PP transmits this information to a 3rd party, for any purpose whatsoever.

This is even true when in a state of bearer hand-over, where the PP is simultaneously 'locked-onto' two FPs. The PP will know both FP's hopping sequences, but it does not share information with either FP.

In actually fact, channel collisions between FPs and PPs can and will take place. These may result in reduced voice quality, but this had to be tolerated.

In the case of 'sequence collisions' (where two transmitters, with overlapping radio cells, are using the same slot, pattern and phase within the pattern), this is detected by multiple consecutive corrupted packets. Each connection that is experiencing sequence collisions will independently attempt the situation (either by pattern changing or by bearer hand-over, as discussed previously).