

# ENGINEERING TEST REPORT



## Wireless Phone Model No.: KX-TD7895

*Applicant:* **Matsushita Electric industrial Co., Ltd.**  
1006, Oaza, Kadoma  
Kadoma, Osaka  
Japan, 571

*In Accordance With*

**FEDERAL COMMUNICATIONS COMMISSION (FCC)  
PART 15, SUBPART C, SEC. 15.247  
Direct Sequence Spread Spectrum Transmitters operating in the  
frequency band 903.75 - 926.25 MHz**

UltraTech's File No.: PAN3-FTX

This Test report is Issued under the Authority of  
Tri M. Luu, Professional Engineer,  
Vice President of Engineering  
UltraTech Group of Labs

Date: July 26, 2000



Report Prepared by: Dan Huynh

Tested by: Mr. Hung Trinh, RFI/EMI Technicain

Issued Date: July 18, 2000

Test Dates: July 11-13, 2000

*The results in this Test Report apply only to the sample(s) tested, and the sample tested is randomly selected.*

## UltraTech

3000 Bristol Circle, Oakville, Ontario, Canada, L6H 6G4  
Telephone (905) 829-1570 Facsimile (905) 829-8050  
Website: [www.ultrat4ech-labs.com](http://www.ultrat4ech-labs.com) Email: [vhk.ultratech@sympatico.ca](mailto:vhk.ultratech@sympatico.ca)

## TABLE OF CONTENTS

<b>EXHIBIT 1. INTRODUCTION .....</b>	<b>1</b>
1.1. SCOPE.....	1
1.2. RELATED SUBMITAL(S)/GRANT(S).....	1
1.3. NORMATIVE REFERENCES .....	1
<b>EXHIBIT 2. PERFORMANCE ASSESSMENT.....</b>	<b>2</b>
2.1. CLIENT INFORMATION .....	2
2.2. EQUIPMENT UNDER TEST (EUT) INFORMATION.....	2
2.3. EUT'S TECHNICAL SPECIFICATIONS .....	3
2.4. LIST OF EUT'S PORTS .....	4
2.5. ANCILLARY EQUIPMENT .....	4
2.6. GENERAL TEST SETUP.....	5
<b>EXHIBIT 3. EUT OPERATING CONDITIONS AND CONFIGURATIONS DURING TESTS.....</b>	<b>6</b>
3.1. CLIMATE TEST CONDITIONS .....	6
3.2. OPERATIONAL TEST CONDITIONS & ARRANGEMENT FOR TESTS.....	6
<b>EXHIBIT 4. SUMMARY OF TEST RESULTS .....</b>	<b>7</b>
4.1. LOCATION OF TESTS .....	7
4.2. APPLICABILITY & SUMMARY OF EMC EMISSION TEST RESULTS .....	7
4.3. MODIFICATIONS INCORPORATED IN THE EUT FOR COMPLIANCE PURPOSES .....	7
<b>EXHIBIT 5. MEASUREMENTS, EXAMINATIONS &amp; TEST DATA FOR EMC EMISSIONS .....</b>	<b>8</b>
5.1. TEST PROCEDURES.....	8
5.2. MEASUREMENT UNCERTAINTIES .....	8
5.3. MEASUREMENT EQUIPMENT USED:.....	8
5.4. ESSENTIAL/PRIMARY FUNCTIONS AS DECLARED BY THE MANUFACTURER:.....	8
5.5. AC POWERLINE CONDUCTED EMISSIONS @ FCC PART 15, SUBPART B, PARA.15.107(A).....	9
5.5.1. <i>Limits</i> .....	9
5.5.2. <i>Method of Measurements</i> .....	9
5.5.3. <i>Test Equipment List</i> .....	9
5.5.4. <i>Test Data</i> .....	9
5.5.5. <i>Photographs of Test Setup</i> .....	9
5.6. 6 dB BANDWIDTH @ FCC 15.247(A)(2).....	10
5.6.1. <i>Limits</i> .....	10
5.6.2. <i>Method of Measurements</i> .....	10
5.6.3. <i>Test Arrangement</i> .....	10
5.6.4. <i>Test Equipment List</i> .....	10
5.6.5. <i>Test Data</i> .....	10
5.7. PEAK OUTPUT POWER & EFFECTIVE RADIATED POWER (EIRP) @ FCC 15.247(B) AND RF EXPOSURE LIMIT FCC 1.1310.....	11
5.7.1. <i>Limits</i> .....	11
5.7.2. <i>Method of Measurements</i> .....	11
5.7.3. <i>Test Arrangement</i> .....	12
5.7.4. <i>Test Equipment List</i> .....	12
5.7.5. <i>Test Data</i> .....	13

---

### ULTRATECH GROUP OF LABS

3000 Bristol Circle, Oakville, Ontario, Canada L6H 6G4

Tel. #: 905-829-1570, Fax. #: 905-829-8050, Email: [vhk.ultratech@sympatico.ca](mailto:vhk.ultratech@sympatico.ca), Website: <http://www.ultratech-labs.com>

File #: PAN3-FTX

July 18, 2000

- Assessed by ITI (UK) Competent Body, NVLAP (USA) Accreditation Body & ACA/AUSTEL (Australia), VCCI (Japan)
- Accredited by Industry Canada (Canada) under ACC-LAB (Europe/Canada MRA and APEC/Canada MRA)
- Recognized/Listed by FCC (USA)
- All test results contained in this engineering test report are traceable to National Institute of Standards and Technology (NIST)

5.8.	SPURIOUS EMISSIONS (CONDUCTED), FCC CFR 47, PARA. 15.247(C).....	15
5.8.1.	<i>Limits</i> .....	15
5.8.2.	<i>Method of Measurements</i> .....	15
5.8.3.	<i>Test Arrangement</i> .....	15
5.8.4.	<i>Test Equipment List</i> .....	15
5.8.5.	<i>Test Data</i> .....	16
5.8.6.	<i>Plots</i> .....	18
5.9.	SPURIOUS EMISSIONS (RADIATED @ 3 METERS), FCC CFR 47, PARA. 15.247(C), 15.209 & 15.205.....	19
5.9.1.	<i>Limits</i> .....	19
5.9.2.	<i>Method of Measurements</i> .....	20
5.9.3.	<i>Test Arrangement</i> .....	20
5.9.4.	<i>Test Equipment List</i> .....	20
5.9.5.	<i>Test Data</i> .....	21
5.9.6.	<i>Plots</i> .....	26
5.10.	TRANSMITTED POWER DENSITY OF A DSSS SYSTEM, FCC CFR 47, PARA. 15.247(D).....	27
5.10.1.	<i>Limits</i> .....	27
5.10.2.	<i>Method of Measurements</i> .....	27
5.10.3.	<i>Test Arrangement</i> .....	27
5.10.4.	<i>Test Equipment List</i> .....	27
5.10.5.	<i>Test Data</i> .....	27
5.10.6.	<i>Plots</i> .....	27
5.11.	PROCESSING GAIN OF A DIRECT SEQUENCE SPREAD SPECTRUM, FCC CFR 47, PARA. 15.247(E).....	28
<b>EXHIBIT 6.</b>	<b>MEASUREMENT UNCERTAINTY</b> .....	<b>33</b>
6.1.	LINE CONDUCTED EMISSION MEASUREMENT UNCERTAINTY.....	33
6.2.	RADIATED EMISSION MEASUREMENT UNCERTAINTY.....	34
<b>EXHIBIT 7.</b>	<b>MEASUREMENT METHODS</b> .....	<b>35</b>
7.1.	GENERAL TEST CONDITIONS.....	35
7.1.1.	<i>Normal temperature and humidity</i> .....	35
7.1.2.	<i>Normal power source</i> .....	35
7.1.3.	<i>Operating Condition of Equipment under Test</i> .....	35
7.2.	METHOD OF MEASUREMENTS - AC MAINS CONDUCTED EMISSIONS.....	36
7.3.	EFFECTIVE RADIATED POWER.....	37
7.4.	SPURIOUS EMISSIONS (CONDUCTED & RADIATED).....	39
7.4.1.	<i>Spurious Emissions (Conducted)</i> .....	39
7.4.2.	<i>Spurious Emissions (Radiated)</i> .....	39
7.5.	TRANSMITTED POWER DENSITY OF A DSSS SYSTEM.....	41
<b>EXHIBIT 8.</b>	<b>TEST SETUP PHOTOGRAPHS</b> .....	<b>42</b>
<b>EXHIBIT 9.</b>	<b>TEST DATA PLOTS</b> .....	<b>43</b>

**ULTRATECH GROUP OF LABS**

3000 Bristol Circle, Oakville, Ontario, Canada L6H 6G4

Tel. #: 905-829-1570, Fax. #: 905-829-8050, Email: [vhk.ultratech@sympatico.ca](mailto:vhk.ultratech@sympatico.ca), Website: <http://www.ultratech-labs.com>

File #: PAN3-FTX

July 18, 2000

- Assessed by ITI (UK) Competent Body, NVLAP (USA) Accreditation Body & ACA/AUSTEL (Australia), VCCI (Japan)
- Accredited by Industry Canada (Canada) under ACC-LAB (Europe/Canada MRA and APEC/Canada MRA)
- Recognized/Listed by FCC (USA)
- All test results contained in this engineering test report are traceable to National Institute of Standards and Technology (NIST)

## EXHIBIT 1. INTRODUCTION

### 1.1. SCOPE

<b>Reference:</b>	FCC Part 15, Subpart C, Section 15.247:1998
<b>Title</b>	Telecommunication - Code of Federal Regulations, CFR 47, Part 15
<b>Purpose of Test:</b>	To gain FCC Certification Authorization for Direct Sequence Spread Spectrum Transmitters operating in the Frequency Band 903.75 - 926.25 MHz .
<b>Test Procedures</b>	Both conducted and radiated emissions measurements were conducted in accordance with American National Standards Institute ANSI C63.4 - American National Standard for Methods of Measurement of Radio-Noise Emissions from Low-Voltage Electrical and Electronic Equipment in the Range of 9 kHz to 40 GHz.
<b>Environmental Classification:</b>	Residential

### 1.2. RELATED SUBMITAL(S)/GRANT(S)

None

### 1.3. NORMATIVE REFERENCES

<b>Publication</b>	<b>YEAR</b>	<b>Title</b>
FCC CFR Parts 0-19	1999	Code of Federal Regulations – Telecommunication
ANSI C63.4	1992	American National Standard for Methods of Measurement of Radio-Noise Emissions from Low-Voltage Electrical and Electronic Equipment in the Range of 9 kHz to 40 GHz
CISPR 22 & EN 55022	1997 1998	Limits and Methods of Measurements of Radio Disturbance Characteristics of Information Technology Equipment
CISPR 16-1		Specification for Radio Disturbance and Immunity measuring apparatus and methods

---

#### ULTRATECH GROUP OF LABS

3000 Bristol Circle, Oakville, Ontario, Canada L6H 6G4

Tel. #: 905-829-1570, Fax. #: 905-829-8050, Email: [vhk.ultratech@sympatico.ca](mailto:vhk.ultratech@sympatico.ca), Website: <http://www.ultratech-labs.com>

File #: PAN3-FTX

July 18, 2000

- Assessed by ITI (UK) Competent Body, NVLAP (USA) Accreditation Body & ACA/AUSTEL (Australia), VCCI (Japan)
- Accredited by Industry Canada (Canada) under ACC-LAB (Europe/Canada MRA and APEC/Canada MRA)
- Recognized/Listed by FCC (USA )
- *All test results contained in this engineering test report are traceable to National Institute of Standards and Technology (NIST)*

## EXHIBIT 2. PERFORMANCE ASSESSMENT

### 2.1. CLIENT INFORMATION

APPLICANT	
<b>Name:</b>	Matsushita Electric Industrial Co., Ltd.
<b>Address:</b>	1006, Oaza, Kadoma Kadoma, Osaka Japan, 571
<b>Contact Person:</b>	Name: Mr. Michihito Miyazaki Phone #: +81-92-477-1405 Fax #: +81-92-477-1487 Email Address: pan44784@pios.kme.mei.co.jp

MANUFACTURER	
<b>Name:</b>	Kyushu Matsushita Electric Co., Ltd.
<b>Address:</b>	4-1-62, Minoshima, Hakata-ku Fukuoka Japan, 812-8531
<b>Contact Person:</b>	Name: Mr. Michihito Miyazaki Phone #: +81-92-477-1407 Fax #: +81-92-477-1487 Email Address: pan44784@pios.kme.mei.co.jp

### 2.2. EQUIPMENT UNDER TEST (EUT) INFORMATION

The following information (with the exception of the Date of Receipt) has been supplied by the applicant.

<b>Brand Name</b>	Panasonic
<b>Product Name</b>	Wireless Phone
<b>Model Name or Number</b>	KX-TD7895
<b>Serial Number</b>	Pre-Production sample
<b>Type of Equipment</b>	Direct Sequence Spread Spectrum Transmitters
<b>Input Power Supply Type</b>	Base unit: DC9V 500mA, AC/DC Adapter model PQLV1 Portable unit: DC3.6V 1500mAH, Ni-MH Battery Pack
<b>Primary User Functions of EUT</b>	Provide data communication link through air

#### ULTRATECH GROUP OF LABS

3000 Bristol Circle, Oakville, Ontario, Canada L6H 6G4

Tel. #: 905-829-1570, Fax. #: 905-829-8050, Email: [vhk.ultratech@sympatico.ca](mailto:vhk.ultratech@sympatico.ca), Website: <http://www.ultratech-labs.com>

File #: PAN3-FTX  
July 18, 2000

- Assessed by ITI (UK) Competent Body, NVLAP (USA) Accreditation Body & ACA/AUSTEL (Australia), VCCI (Japan)
- Accredited by Industry Canada (Canada) under ACC-LAB (Europe/Canada MRA and APEC/Canada MRA)
- Recognized/Listed by FCC (USA)
- All test results contained in this engineering test report are traceable to National Institute of Standards and Technology (NIST)

### 2.3. EUT'S TECHNICAL SPECIFICATIONS

<b>TRANSMITTER</b>	
<b>Equipment Type:</b>	<ul style="list-style-type: none"> <li>• Portable</li> <li>• Base station (fixed use)</li> </ul>
<b>Intended Operating Environment:</b>	<ul style="list-style-type: none"> <li>• Residential</li> </ul>
<b>Power Supply Requirement:</b>	Base unit: 9VDC 500mA DC adaptor Model:PQLV1 Portable Unit:Ni-MH Battery Pack Model:PSPT3HRAAU4165
<b>RF Output Power Rating:</b>	55 mW (Base) 35 mW (Portable)
<b>Operating Frequency Range:</b>	903.75 - 926.25 MHz
<b>RF Output Impedance:</b>	50 Ohms
<b>Channel Spacing:</b>	750KHz
<b>Duty Cycle: (refer to plots # 1 - 2 for details)</b>	45 % (Base Unit) 43 % (Portable Unit)
<b>6 dB Bandwidth:</b>	1.7 MHz
<b>Modulation Type:</b>	FSK (frequency Shift Keying)
<b>Chip Rate/Symbol Rate: (or Theoretical Process Gain)</b>	1.5Mbps/100Kbps
<b>Measured Process Gain:</b>	11.3dB
<b>Emission Designation:</b>	Direct Sequence Spread Spectrum
<b>Oscillator Frequencies:</b>	Tx: 24.0MHz Rx: 24.0MHz Digital (Base): 10.368Mhz, 3.58MHz, 32.768KHz Digital (Portable): 10.368Mhz, 32.768KHz
<b>Spectral Density:</b>	32 mW/MHz (Power output at the antenna / bandwidth of the RF output spectrum)
<b>Antenna Connector Type:</b>	No connector (Integrated Type)
<b>Antenna Description:</b>	(Base) Manufacturer: Sansei Electric Type: half wave-length dipole Model: PSSA1022ZA-SF Frequency Range: 810-950Mhz In/Out Impedance: 50 Ohms Gain (dBi):2.14  (Portable) Manufacturer: Staff corporation Type: 5/8 wave -length hellical Model: PSSA1023ZA-BT Frequency Range: 810-950Mhz In/Out Impedance: 50 Ohms Gain (dBi):2.14

#### ULTRATECH GROUP OF LABS

3000 Bristol Circle, Oakville, Ontario, Canada L6H 6G4

Tel. #: 905-829-1570, Fax. #: 905-829-8050, Email: [vhk.ultratech@sympatico.ca](mailto:vhk.ultratech@sympatico.ca), Website: <http://www.ultratech-labs.com>

File #: PAN3-FTX  
July 18, 2000

- Assessed by ITI (UK) Competent Body, NVLAP (USA) Accreditation Body & ACA/AUSTEL (Australia), VCCI (Japan)
- Accredited by Industry Canada (Canada) under ACC-LAB (Europe/Canada MRA and APEC/Canada MRA)
- Recognized/Listed by FCC (USA)
- All test results contained in this engineering test report are traceable to National Institute of Standards and Technology (NIST)

## 2.4. LIST OF EUT'S PORTS

Port Number	EUT's Port Description	Number of Identical Ports	Connector Type	Cable Type (Shielded/Non-shielded)
1	Telephone Line Jack	1	RJ11	Non-shielded
2	Power Jack	1	DC Jack	Non-shielded

**NOTE:**

1. Ports of the EUT which in normal operation were connected to ancillary equipment through interconnecting cables via a representative interconnecting cable to simulate the input/output characteristics. RF input/output was correctly terminated to the associated antenna.
2. Ports which are not connected to cables during normal intended operation since it is only provided for Service Uses

## 2.5. ANCILLARY EQUIPMENT

The EUT was tested while connected to the following representative configuration of ancillary equipment necessary to exercise the ports during tests:

Ancillary Equipment # 1	
Description:	Telephone Simulator
Brand name:	Teltone
Model No.:	TLS-5A-2
S/N:	019047
Connected to EUT's Port:	Telephone Line Jack

---

### ULTRATECH GROUP OF LABS

3000 Bristol Circle, Oakville, Ontario, Canada L6H 6G4

Tel. #: 905-829-1570, Fax. #: 905-829-8050, Email: [vhk.ultratech@sympatico.ca](mailto:vhk.ultratech@sympatico.ca), Website: <http://www.ultratech-labs.com>

File #: PAN3-FTX  
July 18, 2000

- Assessed by ITI (UK) Competent Body, NVLAP (USA) Accreditation Body & ACA/AUSTEL (Australia), VCCI (Japan)
- Accredited by Industry Canada (Canada) under ACC-LAB (Europe/Canada MRA and APEC/Canada MRA)
- Recognized/Listed by FCC (USA)
- All test results contained in this engineering test report are traceable to National Institute of Standards and Technology (NIST)

## 2.6. GENERAL TEST SETUP

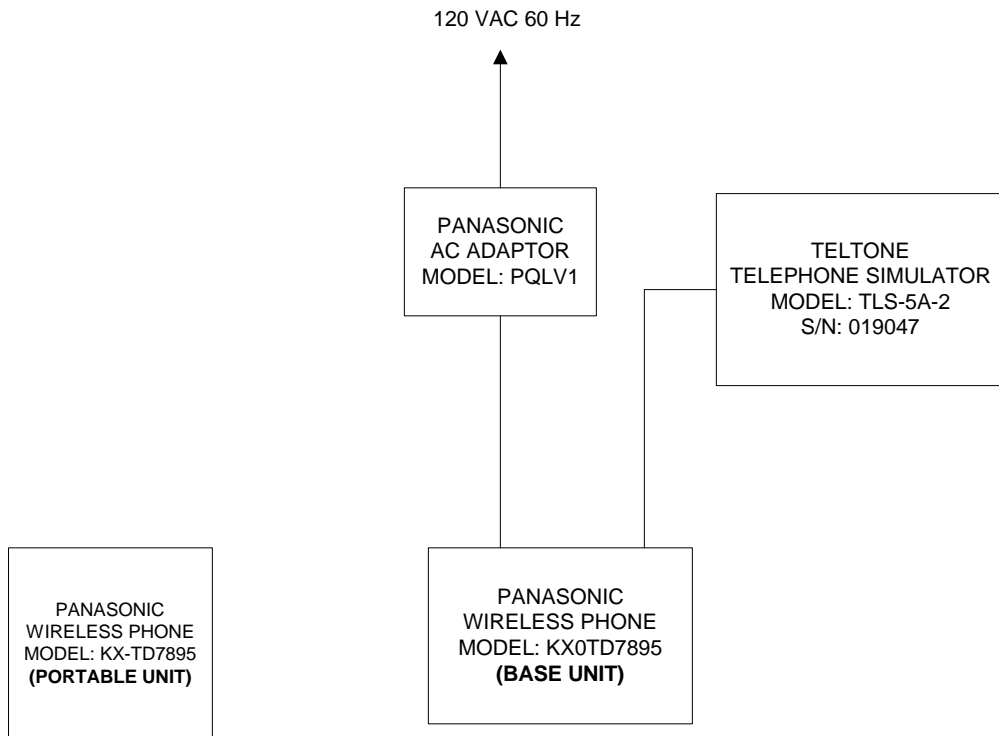

### ULTRATECH GROUP OF LABS

3000 Bristol Circle, Oakville, Ontario, Canada L6H 6G4

Tel. #: 905-829-1570, Fax. #: 905-829-8050, Email: [vhk.ultratech@sympatico.ca](mailto:vhk.ultratech@sympatico.ca), Website: <http://www.ultratech-labs.com>

File #: PAN3-FTX  
July 18, 2000

- Assessed by ITI (UK) Competent Body, NVLAP (USA) Accreditation Body & ACA/AUSTEL (Australia), VCCI (Japan)
- Accredited by Industry Canada (Canada) under ACC-LAB (Europe/Canada MRA and APEC/Canada MRA)
- Recognized/Listed by FCC (USA)
- All test results contained in this engineering test report are traceable to National Institute of Standards and Technology (NIST)

## EXHIBIT 3. EUT OPERATING CONDITIONS AND CONFIGURATIONS DURING TESTS

### 3.1. CLIMATE TEST CONDITIONS

The climate conditions of the test environment are as follows:

Temperature:	21°C
Humidity:	51%
Pressure:	101 kPa
Power input source:	Base Unit: DC9V 500mA, AC/DC Adapter model PQLV1 Portable Unit: DC3.6V 1500mAH, Ni-MH Battery Pack

### 3.2. OPERATIONAL TEST CONDITIONS & ARRANGEMENT FOR TESTS

<b>Operating Modes:</b>	<ul style="list-style-type: none"> <li>▪ Each of lowest, middle and highest channel frequencies transmits continuously for emissions measurements.</li> <li>▪ The EUT operates in normal Direct Sequence mode for occupancy duration, and frequency separation.</li> </ul>
<b>Special Test Software:</b>	<ul style="list-style-type: none"> <li>▪ Special software is provided by the Applicant to select and operate the EUT at each channel frequency continuously. For example, the transmitter will be operated at each of lowest, middle and highest frequencies individually continuously during testing.</li> </ul>
<b>Special Hardware Used:</b>	N/A
<b>Transmitter Test Antenna:</b>	The EUT is tested with the antenna fitted in a manner typical of normal intended use as an integral antenna equipment.

<b>Transmitter Test Signals</b>	
<b>Frequencies:</b>	Lowest, middle and highest channel frequencies tested:
<ul style="list-style-type: none"> <li>▪ 903.75 - 926.25 MHz band:</li> </ul>	903.75 MHz, 914.25 MHz and 926.25 MHz
<b>Transmitter Wanted Output Test Signals:</b>	
<ul style="list-style-type: none"> <li>▪ RF Power Output (measured maximum output power):</li> <li>▪ Normal Test Modulation</li> <li>▪ Modulating signal source:</li> </ul>	<ul style="list-style-type: none"> <li>▪ 0.055 Watts</li> <li>▪ DSSS</li> <li>▪ Internal</li> </ul>

#### ULTRATECH GROUP OF LABS

3000 Bristol Circle, Oakville, Ontario, Canada L6H 6G4

Tel. #: 905-829-1570, Fax. #: 905-829-8050, Email: [vhk.ultratech@sympatico.ca](mailto:vhk.ultratech@sympatico.ca), Website: <http://www.ultratech-labs.com>

File #: PAN3-FTX  
July 18, 2000

- Assessed by ITI (UK) Competent Body, NVLAP (USA) Accreditation Body & ACA/AUSTEL (Australia), VCCI (Japan)
- Accredited by Industry Canada (Canada) under ACC-LAB (Europe/Canada MRA and APEC/Canada MRA)
- Recognized/Listed by FCC (USA)
- All test results contained in this engineering test report are traceable to National Institute of Standards and Technology (NIST)

## EXHIBIT 4. SUMMARY OF TEST RESULTS

### 4.1. LOCATION OF TESTS

All of the measurements described in this report were performed at Ultratech Group of Labs located in the city of Oakville, Province of Ontario, Canada.

- AC Powerline Conducted Emissions were performed in UltraTech's shielded room, 16'(L) by 12'(W) by 12'(H).
- Radiated Emissions were performed at the Ultratech's 3 Meter Open Field Test Site (OFTS) situated in the Town of Oakville, province of Ontario.

The above sites have been calibrated in accordance with ANSI C63.4, and found to be in compliance with the requirements of Sec. 2.948 of the FCC Rules. The descriptions and site measurement data of the Oakville Open Field Test Site has been filed with FCC office (FCC File No.: 31040/SIT 1300B3) and Industry Canada office (Industry Canada File No.: IC2049). Last Date of Site Calibration: Sep.20, 1999.

### 4.2. APPLICABILITY & SUMMARY OF EMC EMISSION TEST RESULTS

FCC PARAGRAPH.	TEST REQUIREMENTS	COMPLIANCE (YES/NO)
15.107, 15.109	AC Power Conducted Emissions & Radiated Emissions for Receiver and Digital Circuit Portions	Yes (Note 1)
15.247(a)(2)	Spectrum Bandwidth of a Direct Sequence Spread Spectrum System	Yes
15.247(b) & 1.1310	Maximum Peak Power and RF Exposure Limits	Yes
15.247(c)	RF Conducted Spurious Emissions at the Transmitter Antenna Terminal	Yes
15.247(c), 15.209 & 15.205	Transmitter Radiated Emissions	Yes
15.247(d)	Transmitted Power Density of a Direct Sequence Spread Spectrum System	Yes
15.247(e)	Processing Gain of Direct Sequence Spread Spectrum System	Yes (Note 2)

**Note 1:** The digital circuits portion of the EUT has been tested and verified to comply with FCC Part 15, Subpart B, Class B Digital Devices and Radio Receivers. The engineering test report can be provided upon FCC requests.

**Note 2:** Kyushu Matsushitta Electric performed the Processing Gain Test.

### 4.3. MODIFICATIONS INCORPORATED IN THE EUT FOR COMPLIANCE PURPOSES

None.

#### ULTRATECH GROUP OF LABS

3000 Bristol Circle, Oakville, Ontario, Canada L6H 6G4

Tel. #: 905-829-1570, Fax. #: 905-829-8050, Email: [vhk.ultratech@sympatico.ca](mailto:vhk.ultratech@sympatico.ca), Website: <http://www.ultratech-labs.com>

File #: PAN3-FTX  
 July 18, 2000

- Assessed by ITI (UK) Competent Body, NVLAP (USA) Accreditation Body & ACA/AUSTEL (Australia), VCCI (Japan)
- Accredited by Industry Canada (Canada) under ACC-LAB (Europe/Canada MRA and APEC/Canada MRA)
- Recognized/Listed by FCC (USA)
- All test results contained in this engineering test report are traceable to National Institute of Standards and Technology (NIST)

---

---

## **EXHIBIT 5. MEASUREMENTS, EXAMINATIONS & TEST DATA FOR EMC EMISSIONS**

### **5.1. TEST PROCEDURES**

This section contains test results only. Details of test methods and procedures can be found in Exhibit 7 of this report

### **5.2. MEASUREMENT UNCERTAINTIES**

The measurement uncertainties stated were calculated in accordance with requirements of UKAS Document NIS 81 with a confidence level of 95%. Please refer to Exhibit 6 for Measurement Uncertainties.

### **5.3. MEASUREMENT EQUIPMENT USED:**

The measurement equipment used complied with the requirements of the Standards referenced in the Methods & Procedures ANSI C64-3:1992, FCC 15.247 and CISPR 16-1.

### **5.4. ESSENTIAL/PRIMARY FUNCTIONS AS DECLARED BY THE MANUFACTURER:**

The essential function of the EUT is to correctly communicate data to and from radios over RF link.

---

---

#### **ULTRATECH GROUP OF LABS**

3000 Bristol Circle, Oakville, Ontario, Canada L6H 6G4

Tel. #: 905-829-1570, Fax. #: 905-829-8050, Email: [vhk.ultratech@sympatico.ca](mailto:vhk.ultratech@sympatico.ca), Website: <http://www.ultratech-labs.com>

File #: PAN3-FTX  
July 18, 2000

- Assessed by ITI (UK) Competent Body, NVLAP (USA) Accreditation Body & ACA/AUSTEL (Australia), VCCI (Japan)
- Accredited by Industry Canada (Canada) under ACC-LAB (Europe/Canada MRA and APEC/Canada MRA)
- Recognized/Listed by FCC (USA)
- *All test results contained in this engineering test report are traceable to National Institute of Standards and Technology (NIST)*

## 5.5. AC POWERLINE CONDUCTED EMISSIONS @ FCC PART 15, SUBPART B, PARA.15.107(A)

### 5.5.1. Limits

The equipment shall meet the limits of the following table:

Test Frequency Range	Test Limits	EMI Detector Used	Measuring Bandwidth
0.45 to 30 MHz	48 dB $\mu$ V 61 dB $\mu$ V	Quasi-Peak (Narrow band) Quasi-Peak (Broad band)	B = 10 kHz B = 10 kHz

### 5.5.2. Method of Measurements

Refer to Exhibit 7, Sec. 7.2 of this test report & ANSI C63-4:1992

### 5.5.3. Test Equipment List

Test Instruments	Manufacturer	Model No.	Serial No.	Frequency Range
Spectrum Analyzer/ EMI Receiver	Hewlett Packard	HP 8593EM	3412A00103	9 kHz – 26.5 GHz
Transient Limiter	Hewlett Packard	11947A	310701998	9 kHz – 200 MHz 10 dB attenuation
L.I.S.N.	EMCO	3825/2	89071531	9 kHz – 200 MHz 50 Ohms / 50 $\mu$ H
12'x16'x12' RF Shielded Chamber	RF Shielding	...	..	...

### 5.5.4. Test Data

Tests were performed on two configurations (Test configuration 1: Portable Unit on dock bay of Battery Charger: Test configuration 2: Base Unit connect to AC Adaptor). The RF signals were scanned from 450kHz to 30 MHz and no significant emission was found. For details, refer to plots # 9 to 12 in Exhibit 9 Test Data Plots.

### 5.5.5. Photographs of Test Setup

Refer to photos #1 to 4 in Exhibit 8 Test Setup Photographs for setup and arrangement of equipment under tests and its ancillary equipment.

## ULTRATECH GROUP OF LABS

3000 Bristol Circle, Oakville, Ontario, Canada L6H 6G4

Tel. #: 905-829-1570, Fax. #: 905-829-8050, Email: [vhk.ultratech@sympatico.ca](mailto:vhk.ultratech@sympatico.ca), Website: <http://www.ultratech-labs.com>

File #: PAN3-FTX  
 July 18, 2000

- Assessed by ITI (UK) Competent Body, NVLAP (USA) Accreditation Body & ACA/AUSTEL (Australia), VCCI (Japan)
- Accredited by Industry Canada (Canada) under ACC-LAB (Europe/Canada MRA and APEC/Canada MRA)
- Recognized/Listed by FCC (USA)
- All test results contained in this engineering test report are traceable to National Institute of Standards and Technology (NIST)

## 5.6. 6 dB BANDWIDTH @ FCC 15.247(a)(2)

### 5.6.1. Limits

For a direct sequence spread spectrum system, the minimum 6 dB bandwidth shall be at least 500 KHz.

### 5.6.2. Method of Measurements

Refer to FCC 15.247(c) & ANSI C63-4:1992

The transmitter output was connected to the spectrum analyzer through an attenuator. The bandwidth of the fundamental frequency was measured with the spectrum analyzer using 30 KHz RBW, VBW = 100 KHz. The 6 dB bandwidth was measured and recorded.

### 5.6.3. Test Arrangement

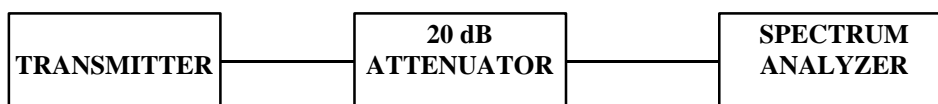

### 5.6.4. Test Equipment List

Test Instruments	Manufacturer	Model No.	Serial No.	Frequency Range
Spectrum Analyzer/ EMI Receiver	Hewlett Packard	HP 8593EM	3412A00103	9 kHz – 26.5 GHz

### 5.6.5. Test Data

CHANNEL FREQUENCY (MHz)	6 dB BANDWIDTH (MHz)	MINIMUM LIMIT (MHz)	PASS/FAIL
<b>Base Unit</b>			
903.75	1.607	0.5	PASS
914.25	1.636	0.5	PASS
926.25	1.636	0.5	PASS
<b>Portable Unit</b>			
903.75	1.629	0.5	PASS
914.25	1.700	0.5	PASS
926.25	1.664	0.5	PASS
Please refer to plots # 3 to 8 in Exhibit 9 for test data measurements.			

## ULTRATECH GROUP OF LABS

3000 Bristol Circle, Oakville, Ontario, Canada L6H 6G4

Tel. #: 905-829-1570, Fax. #: 905-829-8050, Email: [vhk.ultratech@sympatico.ca](mailto:vhk.ultratech@sympatico.ca), Website: <http://www.ultratech-labs.com>

File #: PAN3-FTX  
 July 18, 2000

- Assessed by ITI (UK) Competent Body, NVLAP (USA) Accreditation Body & ACA/AUSTEL (Australia), VCCI (Japan)
- Accredited by Industry Canada (Canada) under ACC-LAB (Europe/Canada MRA and APEC/Canada MRA)
- Recognized/Listed by FCC (USA)
- All test results contained in this engineering test report are traceable to National Institute of Standards and Technology (NIST)

## 5.7. PEAK OUTPUT POWER & EFFECTIVE RADIATED POWER (EIRP) @ FCC 15.247(b) AND RF EXPOSURE LIMIT FCC 1.1310

### 5.7.1. Limits

- **FCC 15.247(b)(1):** Maximum peak output power of the transmitter shall not exceed 1 Watt.
- **FCC 15.247(b)(3):** If the antenna of directional gain greater than 6 dBi are used, the power shall be reduced by the amount in dB that the directional gain of the antenna exceeds 6 dBi.
- **FCC 15.247(b)(3)(i):** Systems operating in the 2400 - 2483.5 MHz band that are used exclusively for fixed, point-to-point operations may employ transmitting antennas with directional gain greater than 6 dBi provided the maximum peak output power of the intentional radiator is reduce by 1 dB for every 3 dB that the directional gain of the antenna exceeds 6 dBi..
- **FCC 1.1310:-** The criteria listed in the following table shall be used to evaluate the environmental impact of human exposure to radio-frequency (RF) radiation as specified in 1.1307(b).

**LIMITS FOR MAXIMUM PERMISSIBLE EXPOSURE (MPE)**

Frequency Range (MHz)	Electric Field Strength (V/m)	Magnetic Field Strength (A/m)	Power Density (mW/cm <sup>2</sup> )	Average Time (minutes)
<b>(A) Limits for Occupational/Control Exposures</b>				
300-1500	...	...	F/300	6
1500-100,000	...	...	5	6
<b>(B) Limits for General Population/Uncontrolled Exposure</b>				
300-1500	...	...	F/1500	6
1500-100,000	...	...	1.0	30

F = Frequency in MHz

### 5.7.2. Method of Measurements

Refer to Exhibit 7, Sec. 7.3 of this test report, FCC 15.247(b)(1)&(3), ANSI C63-4:1992, FCC @ 1.1310 & OST Bulletin No. 65- August 1997

$$S = PG/4\pi r^2 = EIRP/4\pi r^2$$

Where:

- P: power input to the antenna in mW
- EIRP: Equivalent (effective) isotropic radiated power.
- S: power density mW/cm<sup>2</sup>
- G: numeric gain of antenna relative to isotropic radiator
- r: distance to centre of radiation in cm

$$r = \sqrt{PG/4\pi S}$$

FCC radio frequency exposure limits may not be exceeded at distances closer than r cm from the antenna of this device

## ULTRATECH GROUP OF LABS

3000 Bristol Circle, Oakville, Ontario, Canada L6H 6G4

Tel. #: 905-829-1570, Fax. #: 905-829-8050, Email: [vhk.ultratech@sympatico.ca](mailto:vhk.ultratech@sympatico.ca), Website: <http://www.ultratech-labs.com>

File #: PAN3-FTX  
 July 18, 2000

- Assessed by ITI (UK) Competent Body, NVLAP (USA) Accreditation Body & ACA/AUSTEL (Australia), VCCI (Japan)
- Accredited by Industry Canada (Canada) under ACC-LAB (Europe/Canada MRA and APEC/Canada MRA)
- Recognized/Listed by FCC (USA)
- All test results contained in this engineering test report are traceable to National Institute of Standards and Technology (NIST)

5.7.3. Test Arrangement

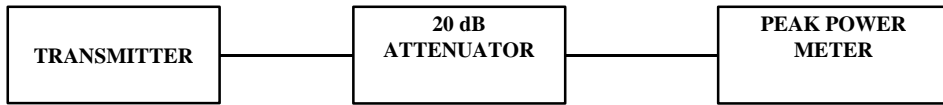

5.7.4. Test Equipment List

Test Instruments	Manufacturer	Model No.	Serial No.	Frequency Range
Spectrum Analyzer/ EMI Receiver	Hewlett Packard	HP 8593EM	3412A00103	9 kHz – 26.5 GHz
Peak Power Meter & Peak Power Sensor	Hewlett Packard	8900 8481A	2131A00124 2551A01965	0.1-18 GHz 50 Ohms Input
Microwave Amplifier	Hewlett Packard	HP 83017A		1 GHz to 26.5 GHz
Horn Antenna	EMCO	3155	9701-5061	1 GHz – 18 GHz
Horn Antenna	EMCO	3155	9911-5955	1 GHz – 18 GHz

**ULTRATECH GROUP OF LABS**

3000 Bristol Circle, Oakville, Ontario, Canada L6H 6G4

Tel. #: 905-829-1570, Fax. #: 905-829-8050, Email: [vhk.ultratech@sympatico.ca](mailto:vhk.ultratech@sympatico.ca), Website: <http://www.ultratech-labs.com>

File #: PAN3-FTX  
July 18, 2000

- Assessed by ITI (UK) Competent Body, NVLAP (USA) Accreditation Body & ACA/AUSTEL (Australia), VCCI (Japan)
- Accredited by Industry Canada (Canada) under ACC-LAB (Europe/Canada MRA and APEC/Canada MRA)
- Recognized/Listed by FCC (USA)
- All test results contained in this engineering test report are traceable to National Institute of Standards and Technology (NIST)

5.7.5. Test Data

5.7.5.1. Base Unit – Sansei Electric half wave-length dipole antenna, model PSSA1022ZA-SF

Duty cycle: **45 %**

Duty Cycle X =  $10 \cdot \log(0.45) = -6.8$  dB. (Please refer to plots # 2 in Exhibit 9 of this test report for details).

**EIRP MEASUREMENTS - CALCULATION METHOD**

Transmitter Channel	Frequency (MHz)	Antenna Gain G (dBi)	(wideband) Peak Power P @ Antenna Port (dBm)	(wideband) Peak EIRP (P+G) (dBm)	(wideband) Average EIRP (Peak EIRP+X) (dBm)	Limit (dBm)
Lowest	903.75	2.14	17.4	19.5	12.7	30
Middle	914.25	2.14	16.5	18.6	11.8	30
Highest	926.25	2.14	17.2	19.3	12.5	30

**EIRP MEASUREMENTS – SUBSTITUTION METHOD**

Frequency (MHz)	E-Field in 100 kHz BW @ 3m (dBμV/m)	Antenna Polarization (V/H)	Total Peak EIRP (dBm)	<sup>1</sup> Total Average EIRP = Peak EIRP+X (dBm)	<sup>2</sup> Safety Distance (cm)
903.75	114.9	V	19.7	12.9	1.6
903.75	109.1	H	13.9	7.1	0.8
914.25	113.8	V	18.6	11.8	1.4
914.25	112.1	H	16.9	10.1	1.2
926.25	114.5	V	19.3	12.5	1.5
926.25	112.9	H	17.7	10.9	1.3

**Notes**

1. X: Duty cycle in dBm
2. Safety Distance are derived using  $r = (PG/4\pi S)^{1/2} = (EIRP/4\pi S)^{1/2}$

**ULTRATECH GROUP OF LABS**

3000 Bristol Circle, Oakville, Ontario, Canada L6H 6G4

Tel. #: 905-829-1570, Fax. #: 905-829-8050, Email: [vhk.ultratech@sympatico.ca](mailto:vhk.ultratech@sympatico.ca), Website: <http://www.ultratech-labs.com>

File #: PAN3-FTX  
 July 18, 2000

- Assessed by ITI (UK) Competent Body, NVLAP (USA) Accreditation Body & ACA/AUSTEL (Australia), VCCI (Japan)
- Accredited by Industry Canada (Canada) under ACC-LAB (Europe/Canada MRA and APEC/Canada MRA)
- Recognized/Listed by FCC (USA)
- All test results contained in this engineering test report are traceable to National Institute of Standards and Technology (NIST)

5.7.5.2. *Portable Unit – Staff Corporation 5/8 wave – length hellical antenna, model PSSA1023ZA-BT*

Duty cycle: **43 %**

Duty Cycle X =  $10 \cdot \log(0.43) = -7.4$  dB. (Please refer to plots # 1 in Exhibit 9 of this test report for details).

**EIRP MEASUREMENTS - CALCULATION METHOD**

Transmitter Channel	Frequency (MHz)	Antenna Gain G (dBi)	(wideband) Peak Power P @ Antenna Port (dBm)	(wideband) Peak EIRP ( P+G) (dBm)	(wideband) Average EIRP (Peak EIRP+X) (dBm)	Limit (dBm)
Lowest	903.75	2.14	15.4	17.5	10.1	30
Middle	914.25	2.14	15.4	17.5	10.1	30
Highest	926.25	2.14	14.6	16.7	9.3	30

**EIRP MEASUREMENTS – SUBSTITUTION METHOD**

Frequency (MHz)	E-Field in 100 kHz BW @ 3m (dBμV/m)	Antenna Polarization (V/H)	Total Peak EIRP (dBm)	Total Average EIRP = Peak EIRP+X (dBm)	RF Exposure Compliance
903.75	109.0	V	13.8	6.4	Pass SAR Limit
903.75	107.6	H	12.4	5.0	Pass SAR Limit
914.25	107.9	V	12.7	5.3	Pass SAR Limit
914.25	107.3	H	12.1	4.7	Pass SAR Limit
926.25	110.0	V	14.8	7.4	Pass SAR Limit
926.25	108.7	H	13.5	6.1	Pass SAR Limit

**ULTRATECH GROUP OF LABS**

3000 Bristol Circle, Oakville, Ontario, Canada L6H 6G4

Tel. #: 905-829-1570, Fax. #: 905-829-8050, Email: [vhk.ultratech@sympatico.ca](mailto:vhk.ultratech@sympatico.ca), Website: <http://www.ultratech-labs.com>

File #: PAN3-FTX  
 July 18, 2000

- Assessed by ITI (UK) Competent Body, NVLAP (USA) Accreditation Body & ACA/AUSTEL (Australia), VCCI (Japan)
- Accredited by Industry Canada (Canada) under ACC-LAB (Europe/Canada MRA and APEC/Canada MRA)
- Recognized/Listed by FCC (USA)
- All test results contained in this engineering test report are traceable to National Institute of Standards and Technology (NIST)

## 5.8. SPURIOUS EMISSIONS (CONDUCTED), FCC CFR 47, PARA. 15.247(c)

### 5.8.1. Limits

In any 100 KHz bandwidth outside the operating frequency band, the radio frequency power that is produced by modulation products of the spreading sequence, the information sequence and the carrier frequency shall be at least 20 dB below that in any 100 KHz bandwidth within the band that contains the highest level of the desired power.

### 5.8.2. Method of Measurements

Refer to Exhibit 7, Sec. 7.4 of this test report, FCC 15.247(c) & ANSI C63-4:1992

### 5.8.3. Test Arrangement

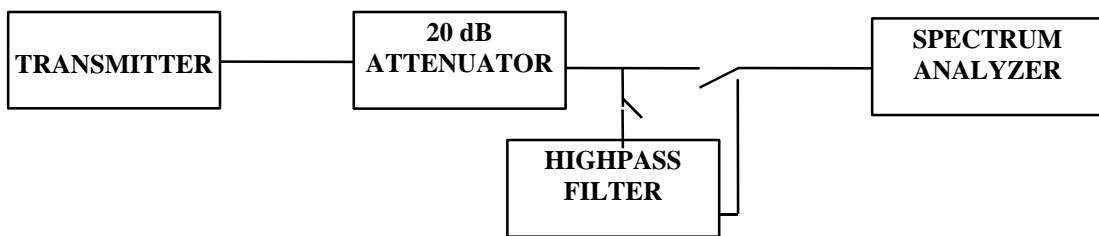

### 5.8.4. Test Equipment List

Test Instruments	Manufacturer	Model No.	Serial No.	Frequency Range
Spectrum Analyzer/ EMI Receiver	Hewlett Packard	HP 8593EM	3412A00103	9 kHz – 26.5 GHz

## ULTRATECH GROUP OF LABS

3000 Bristol Circle, Oakville, Ontario, Canada L6H 6G4

Tel. #: 905-829-1570, Fax. #: 905-829-8050, Email: [vhk.ultratech@sympatico.ca](mailto:vhk.ultratech@sympatico.ca), Website: <http://www.ultratech-labs.com>

File #: PAN3-FTX  
 July 18, 2000

- Assessed by ITI (UK) Competent Body, NVLAP (USA) Accreditation Body & ACA/AUSTEL (Australia), VCCI (Japan)
- Accredited by Industry Canada (Canada) under ACC-LAB (Europe/Canada MRA and APEC/Canada MRA)
- Recognized/Listed by FCC (USA)
- All test results contained in this engineering test report are traceable to National Institute of Standards and Technology (NIST)

5.8.5. Test Data

5.8.5.1. Lowest Frequency (903.75 MHz)

BASE UNIT				
FREQUENCY (MHz)	RF LEVEL 100 kHz BW (dBm)	LIMIT (dBm)	MARGIN (dB)	PASS/FAIL
903.75	15.34	--	--	--
1794	-49.22	-4.66	-44.56	PASS
2693	-48.84	-4.66	-44.18	PASS
3606	-42.91	-4.66	-38.25	PASS

The emissions were scanned from 10 MHz to 10 GHz and all emissions less 50 dB below the limits were recorded.

PORTABLE UNIT				
FREQUENCY (MHz)	RF LEVEL 100 kHz BW (dBm)	LIMIT (dBm)	MARGIN (dB)	PASS/FAIL
903.75	9.66	--	--	--
196	-60.66	-10.34	-50.32	PASS
1794	-48.09	-10.34	-37.75	PASS
2707	-49.97	-10.34	-39.63	PASS
3606	-57.06	-10.34	-46.72	PASS

The emissions were scanned from 10 MHz to 10 GHz and all emissions less 50 dB below the limits were recorded.

**ULTRATECH GROUP OF LABS**

3000 Bristol Circle, Oakville, Ontario, Canada L6H 6G4

Tel. #: 905-829-1570, Fax. #: 905-829-8050, Email: [vhk.ultratech@sympatico.ca](mailto:vhk.ultratech@sympatico.ca), Website: <http://www.ultratech-labs.com>

File #: PAN3-FTX  
 July 18, 2000

- Assessed by ITI (UK) Competent Body, NVLAP (USA) Accreditation Body & ACA/AUSTEL (Australia), VCCI (Japan)
- Accredited by Industry Canada (Canada) under ACC-LAB (Europe/Canada MRA and APEC/Canada MRA)
- Recognized/Listed by FCC (USA)
- All test results contained in this engineering test report are traceable to National Institute of Standards and Technology (NIST)

5.8.5.2. Middle Frequency (914.25 MHz)

BASE UNIT				
FREQUENCY (MHz)	RF LEVEL 100 kHz BW (dBm)	LIMIT (dBm)	MARGIN (dB)	PASS/FAIL
914.25	13.78	--	--	--
2736	-50.06	-6.22	-43.84	PASS
3649	-43.34	-6.22	-37.12	PASS

The emissions were scanned from 10 MHz to 10 GHz and all emissions less 50 dB below the limits were recorded.

PORTABLE UNIT				
FREQUENCY (MHz)	RF LEVEL 100 kHz BW (dBm)	LIMIT (dBm)	MARGIN (dB)	PASS/FAIL
914.25	9.72	--	--	--
1822	-51.66	-10.28	-41.38	PASS
2736	-46.84	-10.28	-36.56	PASS

The emissions were scanned from 10 MHz to 10 GHz and all emissions less 50 dB below the limits were recorded.

**ULTRATECH GROUP OF LABS**

3000 Bristol Circle, Oakville, Ontario, Canada L6H 6G4

Tel. #: 905-829-1570, Fax. #: 905-829-8050, Email: [vhk.ultratech@sympatico.ca](mailto:vhk.ultratech@sympatico.ca), Website: <http://www.ultratech-labs.com>

File #: PAN3-FTX

July 18, 2000

- Assessed by ITI (UK) Competent Body, NVLAP (USA) Accreditation Body & ACA/AUSTEL (Australia), VCCI (Japan)
- Accredited by Industry Canada (Canada) under ACC-LAB (Europe/Canada MRA and APEC/Canada MRA)
- Recognized/Listed by FCC (USA)
- All test results contained in this engineering test report are traceable to National Institute of Standards and Technology (NIST)

5.8.5.3. *Highest Frequency (926.25 MHz)*

BASE UNIT				
FREQUENCY (MHz)	RF LEVEL 100 kHz BW (dBm)	LIMIT (dBm)	MARGIN (dB)	PASS/FAIL
926.25	13.84	--	--	--
2764	-44.50	-6.16	-38.34	PASS

The emissions were scanned from 10 MHz to 10 GHz and all emissions less 50 dB below the limits were recorded.

PORTABLE UNIT				
FREQUENCY (MHz)	RF LEVEL 100 kHz BW (dBm)	LIMIT (dBm)	MARGIN (dB)	PASS/FAIL
926.25	9.63	--	--	--
196	-59.53	-10.37	-49.16	PASS
1837	-46.13	-10.37	-35.76	PASS
2764	-49.69	-10.37	-39.32	PASS

The emissions were scanned from 10 MHz to 10 GHz and all emissions less 50 dB below the limits were recorded.

5.8.6. **Plots**

Please refer to plots # 13 through 24 in Exhibit 9 Test Data Plots for details.

**ULTRATECH GROUP OF LABS**

3000 Bristol Circle, Oakville, Ontario, Canada L6H 6G4

Tel. #: 905-829-1570, Fax. #: 905-829-8050, Email: [vhk.ultratech@sympatico.ca](mailto:vhk.ultratech@sympatico.ca), Website: <http://www.ultratech-labs.com>

File #: PAN3-FTX  
 July 18, 2000

- Assessed by ITI (UK) Competent Body, NVLAP (USA) Accreditation Body & ACA/AUSTEL (Australia), VCCI (Japan)
- Accredited by Industry Canada (Canada) under ACC-LAB (Europe/Canada MRA and APEC/Canada MRA)
- Recognized/Listed by FCC (USA)
- *All test results contained in this engineering test report are traceable to National Institute of Standards and Technology (NIST)*

**5.9. SPURIOUS EMISSIONS (RADIATED @ 3 METERS), FCC CFR 47, PARA. 15.247(c), 15.209 & 15.205**

**5.9.1. Limits**

In any 100 KHz bandwidth outside the operating frequency band, the radio frequency power that is produced by modulation products of the spreading sequence, the information sequence and the carrier frequency shall be either at least 20 dB below that in any 100 KHz bandwidth within the band that contains the highest level of the desired power or shall not exceed the general levels specified in @ 15.209(a), which lesser attenuation.

All other emissions inside restricted bands specified in @ 15.205(a) shall not exceed the general radiated emission limits specified in @ 15.209(a)

**Remarks:**

- Applies to harmonics/spurious emissions that fall in the restricted bands listed in Section 15.205. The maximum permitted average field strength is listed in Section 15.209.
- @ **FCC CFR 47, Para. 15.237(c)** - The emission limits as specified above are based on measurement instrument employing an average detector. The provisions in @15.35 for limiting peak emissions apply.

**FCC CFR 47, Part 15, Subpart C, Para. 15.205(a) - Restricted Frequency Bands**

MHz	MHz	MHz	GHz
0.090 - 0.110	16.42 - 16.423	399.9 - 410	4.5 - 5.15
0.495 - 0.505	16.69475 - 16.69525	608 - 614	5.35 - 5.46
2.1735 - 2.1905	16.80425 - 16.80475	960 - 1240	7.25 - 7.75
4.125 - 4.128	25.5 - 25.67	1300 - 1427	8.025 - 8.5
4.17725 - 4.17775	37.5 - 38.25	1435 - 1626.5	9.0 - 9.2
4.20725 - 4.20775	73 - 74.6	1645.5 - 1646.5	9.3 - 9.5
6.215 - 6.218	74.8 - 75.2	1660 - 1710	10.6 - 12.7
6.26775 - 6.26825	108 - 121.94	1718.8 - 1722.2	13.25 - 13.4
6.31175 - 6.31225	123 - 138	2200 - 2300	14.47 - 14.5
8.291 - 8.294	149.9 - 150.05	2310 - 2390	15.35 - 16.2
8.362 - 8.366	156.52475 - 156.52525	2483.5 - 2500	17.7 - 21.4
8.37625 - 8.38675	156.7 - 156.9	2655 - 2900	22.01 - 23.12
8.41425 - 8.41475	162.0125 - 167.17	3260 - 3267	23.6 - 24.0
12.29 - 12.293	167.72 - 173.2	3332 - 3339	31.2 - 31.8
12.51975 - 12.52025	240 - 285	3345.8 - 3358	36.43 - 36.5
12.57675 - 12.57725	322 - 335.4	3600 - 4400	Above 38.6
13.36 - 13.41			

**ULTRATECH GROUP OF LABS**

3000 Bristol Circle, Oakville, Ontario, Canada L6H 6G4

Tel. #: 905-829-1570, Fax. #: 905-829-8050, Email: [vhk.ultratech@sympatico.ca](mailto:vhk.ultratech@sympatico.ca), Website: <http://www.ultratech-labs.com>

File #: PAN3-FTX  
 July 18, 2000

- Assessed by ITI (UK) Competent Body, NVLAP (USA) Accreditation Body & ACA/AUSTEL (Australia), VCCI (Japan)
- Accredited by Industry Canada (Canada) under ACC-LAB (Europe/Canada MRA and APEC/Canada MRA)
- Recognized/Listed by FCC (USA)
- All test results contained in this engineering test report are traceable to National Institute of Standards and Technology (NIST)

**FCC CFR 47, Part 15, Subpart C, Para. 15.209(a)**  
**-- Field Strength Limits within Restricted Frequency Bands --**

<b>FREQUENCY (MHz)</b>	<b>FIELD STRENGTH LIMITS (microvolts/m)</b>	<b>DISTANCE (Meters)</b>
0.009 - 0.490	2,400 / F (KHz)	300
0.490 - 1.705	24,000 / F (KHz)	30
1.705 - 30.0	30	30
30 - 88	100	3
88 - 216	150	3
216 - 960	200	3
Above 960	500	3

**5.9.2. Method of Measurements**

Refer to Exhibit 7, Sec. 7.4 of this test report and **ANSI 63.4-1992, Para. 8** for detailed radiated emissions measurement procedures.

The following measurement procedures were also applied:

- Applies to harmonics/spurious that fall in the restricted bands listed in Section 15.205. the maximum permitted average field strength is listed in Section 15.209. A Pre-Amp and highpass filter are used for this measurement.
- For measurement below 1 GHz, set RBW = 100 KHz, VBW ≥ 100 KHz, SWEEP=AUTO.
- For measurement above 1 GHz, set RBW = 1 MHz, VBW = 1 MHz (Peak) & VBW = 10 Hz (Average), SWEEP=AUTO.
- If the emission is pulsed, modified the unit for continuous operation, then use the settings above for measurements, then correct the reading by subtracting the peak-average correction factor derived from the appropriate duty cycle calculation. See Section 15.35(b) and (c).

**5.9.3. Test Arrangement**

Please refer to general test setup in Sec. 2.6 for details of test setup for emission measurements.

**5.9.4. Test Equipment List**

<b>Test Instruments</b>	<b>Manufacturer</b>	<b>Model No.</b>	<b>Serial No.</b>	<b>Frequency Range</b>
Spectrum Analyzer/ EMI Receiver	Advantest	R3271	15050203	100 Hz to 32 GHz with external mixer for frequency above 32 GHz
Microwave Amplifier	Hewlett Packard	HP 83017A		1 GHz to 26.5 GHz
Biconilog Antenna	EMCO	3143	1029	20 MHz to 2 GHz
Horn Antenna	EMCO	3155	9701-5061	1 GHz - 18 GHz
Horn Antenna	EMCO	3160-09	..	18 GHz - 26.5 GHz
Horn Antenna	EMCO	3160-10	..	26.5 GHz - 40 GHz
Mixer	Tektronix	118-0098-00	..	18 GHz - 26.5 GHz
Mixer	Tektronix	119-0098-00	..	26.5 GHz - 40 GHz

**ULTRATECH GROUP OF LABS**

3000 Bristol Circle, Oakville, Ontario, Canada L6H 6G4

Tel. #: 905-829-1570, Fax. #: 905-829-8050, Email: [vhk.ultratech@sympatico.ca](mailto:vhk.ultratech@sympatico.ca), Website: <http://www.ultratech-labs.com>

File #: PAN3-FTX  
 July 18, 2000

- Assessed by ITI (UK) Competent Body, NVLAP (USA) Accreditation Body & ACA/AUSTEL (Australia), VCCI (Japan)
- Accredited by Industry Canada (Canada) under ACC-LAB (Europe/Canada MRA and APEC/Canada MRA)
- Recognized/Listed by FCC (USA)
- *All test results contained in this engineering test report are traceable to National Institute of Standards and Technology (NIST)*

5.9.5. Test Data

5.9.5.1. Lowest Frequency (903.75 MHz)

BASE UNIT							
FREQUENCY (MHz)	RF PEAK LEVEL (dBµV/m)	RF AVG LEVEL (dBµV/m)	ANTENNA PLANE (H/V)	LIMIT 15.209 (dBµV/m)	LIMIT 15.247 (dBµV/m)	MARGIN (dB)	PASS/FAIL
903.75	116.49	--	V	--	--	--	--
903.75	110.64	--	H	--	--	--	--
1807.5	57.34	32.89	V	54.0	96.5	-63.6	PASS
1807.5	55.91	31.81	H	54.0	96.5	-64.7	PASS
2711.25	46.84	27.29	V	54.0	96.5	-26.7	PASS*
2711.25	47.78	26.98	H	54.0	96.5	-27.0	PASS*
3615.00	62.91	35.98	V	54.0	96.5	-18.0	PASS*
3615.00	64.75	36.54	H	54.0	96.5	-17.5	PASS*

The emissions were scanned from 10 MHz to 10 GHz and all emissions less 65 dB below the limits were recorded.

\* Emission within the restricted band specified @ 15.205(a)

Panasonic Wireless Phone, Model KX-TD7895 (Base Unit)  
 Transmitter Radiated Emissions Measurements at 3 Meters OFTS  
 Transmit Frequency: 903.75 MHz

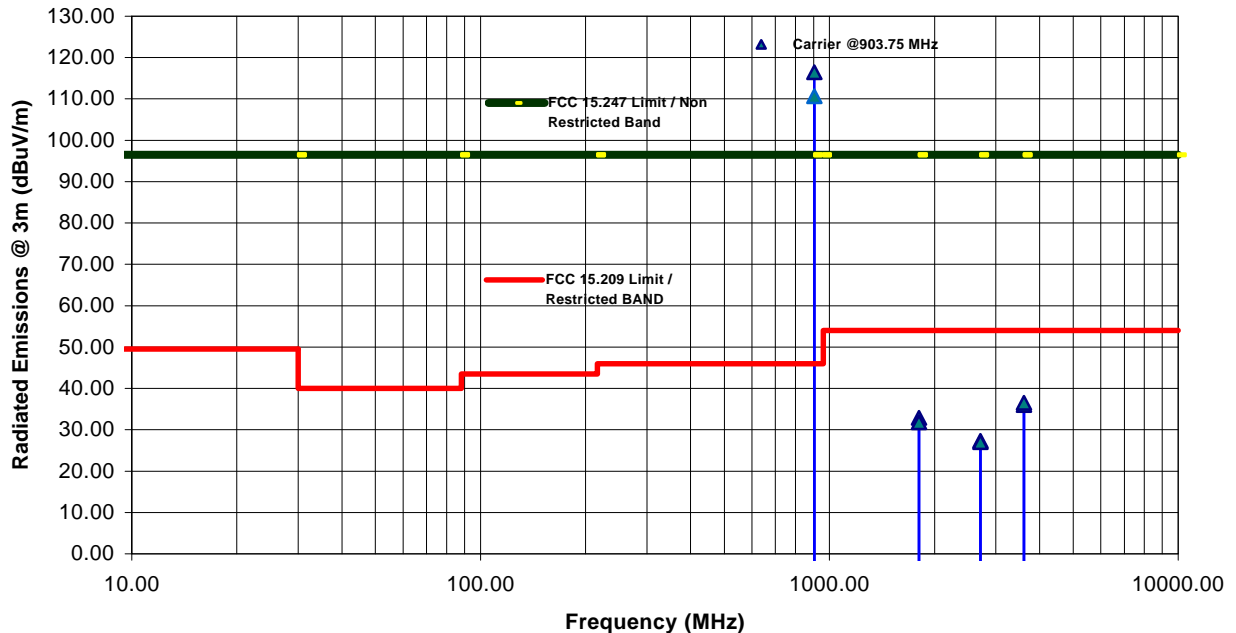

ULTRATECH GROUP OF LABS

3000 Bristol Circle, Oakville, Ontario, Canada L6H 6G4

Tel. #: 905-829-1570, Fax. #: 905-829-8050, Email: [vhk.ultratech@sympatico.ca](mailto:vhk.ultratech@sympatico.ca), Website: <http://www.ultratech-labs.com>

File #: PAN3-FTX

July 18, 2000

- Assessed by ITI (UK) Competent Body, NVLAP (USA) Accreditation Body & ACA/AUSTEL (Australia), VCCI (Japan)
- Accredited by Industry Canada (Canada) under ACC-LAB (Europe/Canada MRA and APEC/Canada MRA)
- Recognized/Listed by FCC (USA)
- All test results contained in this engineering test report are traceable to National Institute of Standards and Technology (NIST)

PORTABLE UNIT							
FREQUENCY (MHz)	RF PEAK LEVEL (dBμV/m)	RF AVG LEVEL (dBμV/m)	ANTENNA PLANE (H/V)	LIMIT 15.209 (dBμV/m)	LIMIT 15.247 (dBμV/m)	MARGIN (dB)	PASS/ FAIL
903.75	110.57	--	V	--	--	--	--
903.75	109.19	--	H	--	--	--	--
1807.90	53.19	28.98	V	54.0	90.6	-61.6	PASS
1807.90	49.63	26.23	H	54.0	90.6	-64.3	PASS
2711.85	42.53	23.32	V	54.0	90.6	-30.7	PASS*
2711.85	42.94	23.66	H	54.0	90.6	-30.3	PASS*
3615.80	51.78	28.54	V	54.0	90.6	-25.5	PASS*
3615.80	50.46	28.51	H	54.0	90.6	-25.5	PASS*

The emissions were scanned from 10 MHz to 10 GHz and all emissions less 65 dB below the limits were recorded.

\* Emission within the restricted band specified @ 15.205(a)

**Panasonic Wireless Phone, Model KX-TD7895 (Portable Unit)  
 Transmitter Radiated Emissions Measurements at 3 Meters OFTS  
 Transmit Frequency: 903.75 MHz**

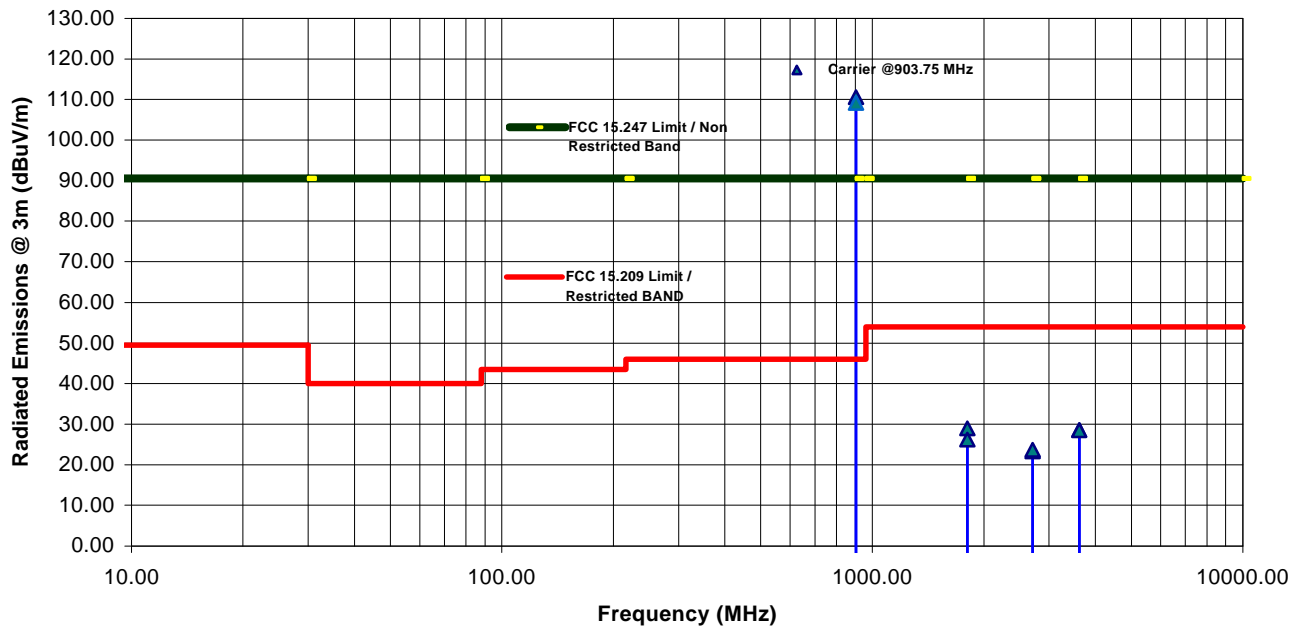

**ULTRATECH GROUP OF LABS**

3000 Bristol Circle, Oakville, Ontario, Canada L6H 6G4

Tel. #: 905-829-1570, Fax. #: 905-829-8050, Email: [vhk.ultratech@sympatico.ca](mailto:vhk.ultratech@sympatico.ca), Website: <http://www.ultratech-labs.com>

File #: PAN3-FTX

July 18, 2000

- Assessed by ITI (UK) Competent Body, NVLAP (USA) Accreditation Body & ACA/AUSTEL (Australia), VCCI (Japan)
- Accredited by Industry Canada (Canada) under ACC-LAB (Europe/Canada MRA and APEC/Canada MRA)
- Recognized/Listed by FCC (USA)
- All test results contained in this engineering test report are traceable to National Institute of Standards and Technology (NIST)

5.9.5.2. Middle Frequency (914.25 MHz)

BASE UNIT							
FREQUENCY (MHz)	RF PEAK LEVEL (dBµV/m)	RF AVG LEVEL (dBµV/m)	ANTENNA PLANE (H/V)	LIMIT 15.209 (dBµV/m)	LIMIT 15.247 (dBµV/m)	MARGIN (dB)	PASS/ FAIL
914.25	115.43	--	V	--	--	--	--
914.25	113.71	--	H	--	--	--	--
1828.50	55.94	31.89	V	54.0	95.4	-63.5	PASS
1828.50	57.44	32.73	H	54.0	95.4	-62.7	PASS
2742.75	53.47	29.89	V	54.0	95.4	-24.1	PASS*
2742.75	51.63	29.48	H	54.0	95.4	-24.5	PASS*
3657.00	61.19	35.33	V	54.0	95.4	-18.7	PASS*
3657.00	64.96	37.11	H	54.0	95.4	-16.9	PASS*

The emissions were scanned from 10 MHz to 10 GHz and all emissions less 65 dB below the limits were recorded.

\* Emission within the restricted band specified @ 15.205(a)

Panasonic Wireless Phone, Model KX-TD7895 (Base Unit)  
 Transmitter Radiated Emissions Measurements at 3 Meters OFTS  
 Transmit Frequency: 914.25 MHz

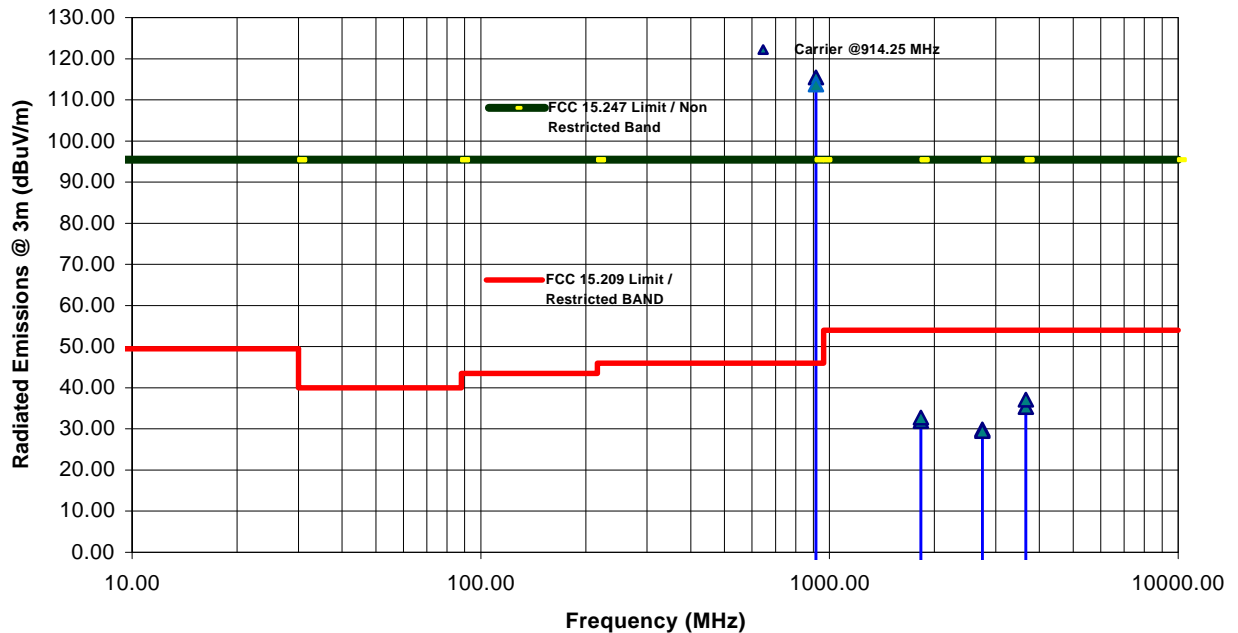

ULTRATECH GROUP OF LABS

3000 Bristol Circle, Oakville, Ontario, Canada L6H 6G4

Tel. #: 905-829-1570, Fax. #: 905-829-8050, Email: vnk.ultratech@sympatico.ca, Website: http://www.ultratech-labs.com

File #: PAN3-FTX

July 18, 2000

- Assessed by ITI (UK) Competent Body, NVLAP (USA) Accreditation Body & ACA/AUSTEL (Australia), VCCI (Japan)
- Accredited by Industry Canada (Canada) under ACC-LAB (Europe/Canada MRA and APEC/Canada MRA)
- Recognized/Listed by FCC (USA)
- All test results contained in this engineering test report are traceable to National Institute of Standards and Technology (NIST)

PORTABLE UNIT							
FREQUENCY (MHz)	RF PEAK LEVEL (dBμV/m)	RF AVG LEVEL (dBμV/m)	ANTENNA PLANE (H/V)	LIMIT 15.209 (dBμV/m)	LIMIT 15.247 (dBμV/m)	MARGIN (dB)	PASS/FAIL
914.25	109.51	--	V	--	--	--	--
914.25	108.88	--	H	--	--	--	--
1828.50	50.28	27.88	V	54.0	89.5	-61.6	PASS
1828.50	47.63	25.35	H	54.0	89.5	-64.2	PASS
2742.75	43.69	24.13	V	54.0	89.5	-29.9	PASS*
2742.75	43.94	24.19	H	54.0	89.5	-29.8	PASS*
3657.00	49.84	28.91	V	54.0	89.5	-25.1	PASS*
3657.00	49.56	27.63	H	54.0	89.5	-26.4	PASS*

The emissions were scanned from 10 MHz to 10 GHz and all emissions less 65 dB below the limits were recorded.

\* Emission within the restricted band specified @ 15.205(a)

**Panasonic Wireless Phone, Model KX-TD7895 (Portable Unit)**  
**Transmitter Radiated Emissions Measurements at 3 Meters OFTS**  
**Transmit Frequency: 914.25 MHz**

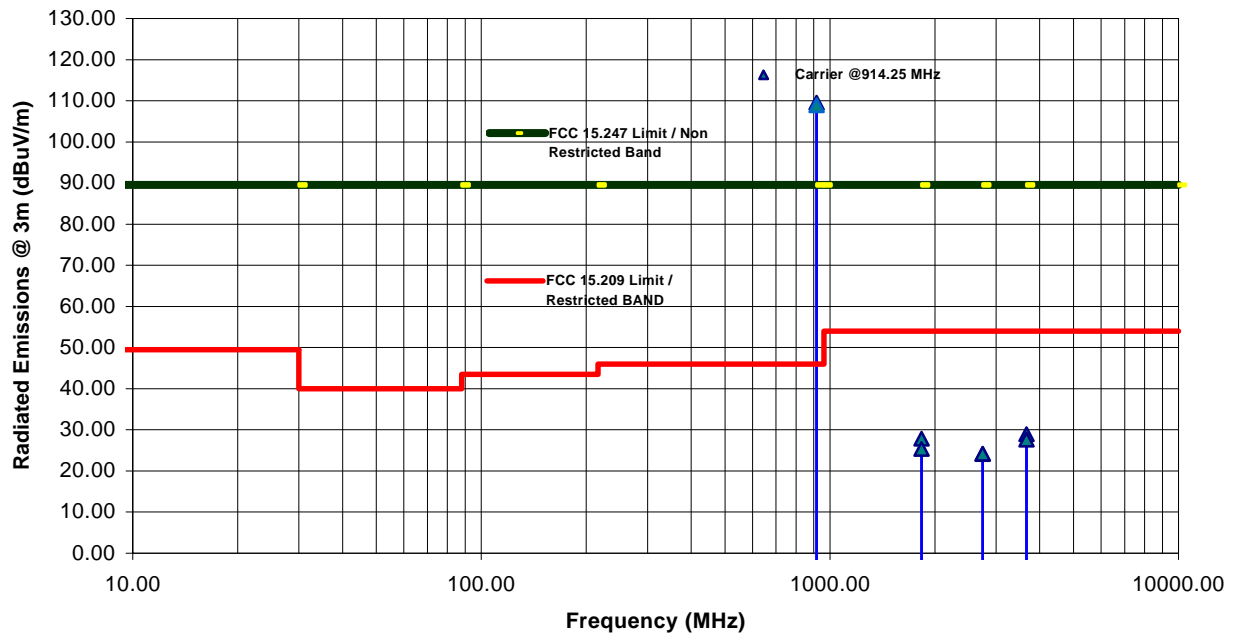

**ULTRATECH GROUP OF LABS**

3000 Bristol Circle, Oakville, Ontario, Canada L6H 6G4

Tel. #: 905-829-1570, Fax. #: 905-829-8050, Email: [vhk.ultratech@sympatico.ca](mailto:vhk.ultratech@sympatico.ca), Website: <http://www.ultratech-labs.com>

File #: PAN3-FTX

July 18, 2000

- Assessed by ITI (UK) Competent Body, NVLAP (USA) Accreditation Body & ACA/AUSTEL (Australia), VCCI (Japan)
- Accredited by Industry Canada (Canada) under ACC-LAB (Europe/Canada MRA and APEC/Canada MRA)
- Recognized/Listed by FCC (USA)
- All test results contained in this engineering test report are traceable to National Institute of Standards and Technology (NIST)

5.9.5.3. Highest Frequency (926.25 MHz)

BASE UNIT							
FREQUENCY (MHz)	RF PEAK LEVEL (dBµV/m)	RF AVG LEVEL (dBµV/m)	ANTENNA PLANE (H/V)	LIMIT 15.209 (dBµV/m)	LIMIT 15.247 (dBµV/m)	MARGIN (dB)	PASS/FAIL
926.25	116.06	--	V	--	--	--	--
926.25	114.50	--	H	--	--	--	--
1852.50	53.50	32.41	V	54.0	96.1	-63.7	PASS
1852.50	55.94	32.64	H	54.0	96.1	-63.4	PASS
2778.75	55.47	31.70	V	54.0	96.1	-22.3	PASS*
2778.75	54.56	30.76	H	54.0	96.1	-23.2	PASS*
3705.00	53.34	31.92	V	54.0	96.1	-22.1	PASS*
3705.00	55.06	33.29	H	54.0	96.1	-20.7	PASS*

The emissions were scanned from 10 MHz to 10 GHz and all emissions less 65 dB below the limits were recorded.

\* Emission within the restricted band specified @ 15.205(a)

Panasonic Wireless Phone, Model KX-TD7895 (Base Unit)  
 Transmitter Radiated Emissions Measurements at 3 Meters OFTS  
 Transmit Frequency: 926.25 MHz

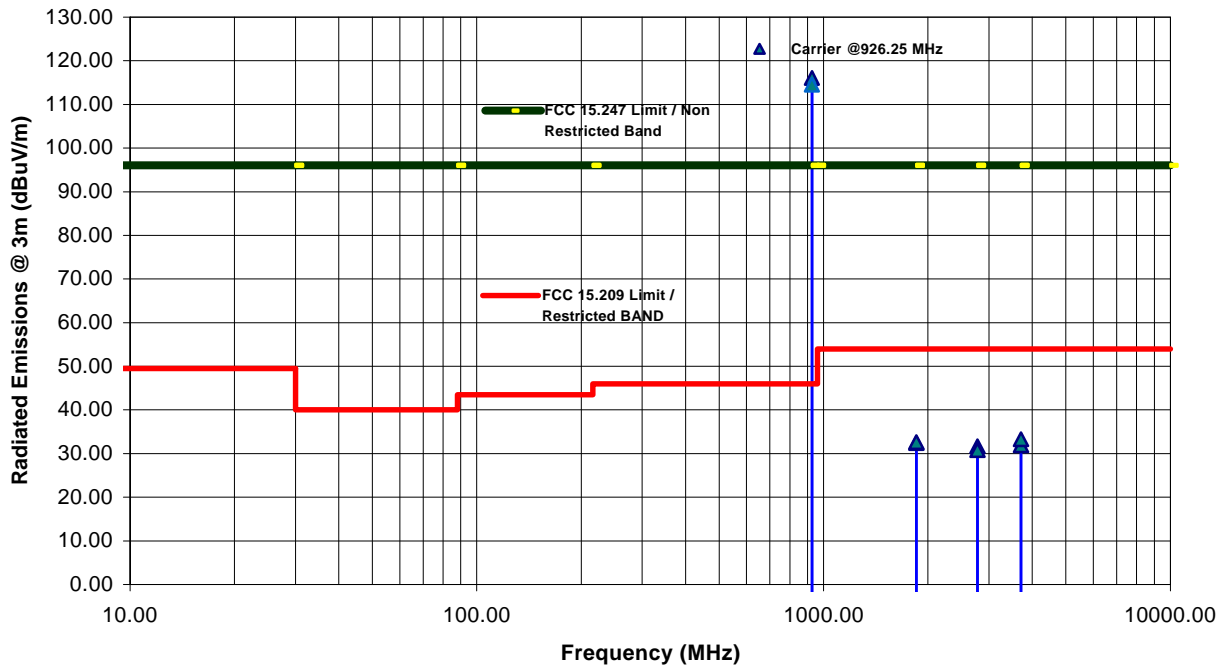

ULTRATECH GROUP OF LABS

3000 Bristol Circle, Oakville, Ontario, Canada L6H 6G4

Tel. #: 905-829-1570, Fax. #: 905-829-8050, Email: [vhk.ultratech@sympatico.ca](mailto:vhk.ultratech@sympatico.ca), Website: <http://www.ultratech-labs.com>

File #: PAN3-FTX

July 18, 2000

- Assessed by ITI (UK) Competent Body, NVLAP (USA) Accreditation Body & ACA/AUSTEL (Australia), VCCI (Japan)
- Accredited by Industry Canada (Canada) under ACC-LAB (Europe/Canada MRA and APEC/Canada MRA)
- Recognized/Listed by FCC (USA)
- All test results contained in this engineering test report are traceable to National Institute of Standards and Technology (NIST)

PORTABLE UNIT							
FREQUENCY (MHz)	RF PEAK LEVEL (dB $\mu$ V/m)	RF AVG LEVEL (dB $\mu$ V/m)	ANTENNA PLANE (H/V)	LIMIT 15.209 (dB $\mu$ V/m)	LIMIT 15.247 (dB $\mu$ V/m)	MARGIN (dB)	PASS/FAIL
926.25	111.54	--	V	--	--	--	--
926.25	110.33	--	H	--	--	--	--
1852.50	50.09	27.54	V	54.0	91.5	-64.0	PASS
1852.50	48.81	26.01	H	54.0	91.5	-65.5	PASS
2778.75	43.81	24.23	V	54.0	91.5	-29.8	PASS*
2778.75	42.91	24.60	H	54.0	91.5	-29.4	PASS*
3705.00	48.84	28.01	V	54.0	91.5	-26.0	PASS*
3705.00	49.16	28.82	H	54.0	91.5	-25.2	PASS*

The emissions were scanned from 10 MHz to 10 GHz and all emissions less 65 dB below the limits were recorded.

\* Emission within the restricted band specified @ 15.205(a)

**Panasonic Wireless Phone, Model KX-TD7895 (Portable Unit)**  
**Transmitter Radiated Emissions Measurements at 3 Meters OFTS**  
**Transmit Frequency: 926.25 MHz**

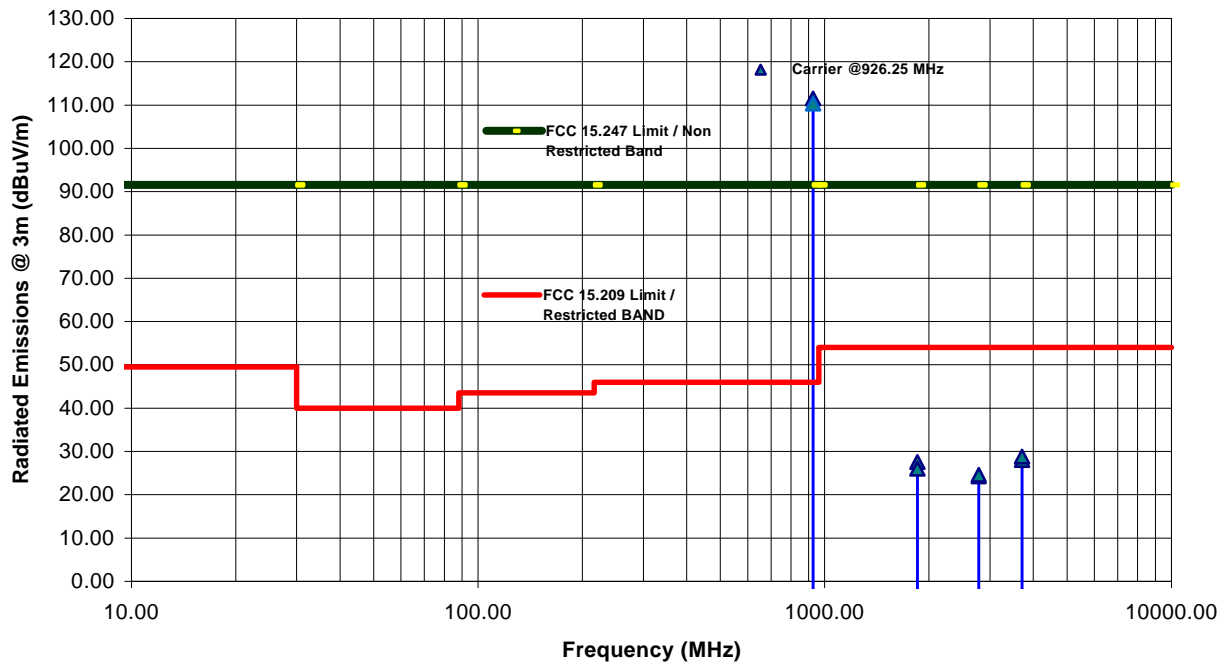

**5.9.6. Plots**

Refer to plots # 25 through 36 in Exhibit 9 Test Data Plots for details.

**ULTRATECH GROUP OF LABS**

3000 Bristol Circle, Oakville, Ontario, Canada L6H 6G4

Tel. #: 905-829-1570, Fax. #: 905-829-8050, Email: [vhk.ultratech@sympatico.ca](mailto:vhk.ultratech@sympatico.ca), Website: <http://www.ultratech-labs.com>

File #: PAN3-FTX

July 18, 2000

- Assessed by ITI (UK) Competent Body, NVLAP (USA) Accreditation Body & ACA/AUSTEL (Australia), VCCI (Japan)
- Accredited by Industry Canada (Canada) under ACC-LAB (Europe/Canada MRA and APEC/Canada MRA)
- Recognized/Listed by FCC (USA)
- All test results contained in this engineering test report are traceable to National Institute of Standards and Technology (NIST)

**5.10. TRANSMITTED POWER DENSITY OF A DSSS SYSTEM, FCC CFR 47, PARA. 15.247(d)**

**5.10.1. Limits**

For a direct sequence system, the transmitted power density average over any 1 second interval shall not be greater than 8 dBm in any 3 KHz bandwidth within this band.

**5.10.2. Method of Measurements**

Refer to Exhibit 7, Sec. 7.5 of this test report for detailed measurement procedures

**5.10.3. Test Arrangement**

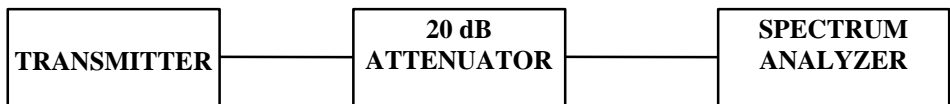

**5.10.4. Test Equipment List**

Test Instruments	Manufacturer	Model No.	Serial No.	Frequency Range
Spectrum Analyzer/ EMI Receiver	Hewlett Packard	HP 8593EM	3412A00103	9 kHz – 26.5 GHz

**5.10.5. Test Data**

CHANNEL NUMBER	CHANNEL FREQUENCY (MHz)	RF POWER LEVEL IN 3 KHz BW (dBm)	LIMIT (dBm)	MARGIN (dB)	COMMENTS (PASS/FAIL)
<b>BASE UNIT</b>					
Lowest	903.75	5.84	8.0	-2.2	PASS
Middle	914.25	3.56	8.0	-4.4	PASS
Highest	926.25	5.72	8.0	-2.3	PASS
<b>PORTABLE UNIT</b>					
Lowest	903.75	4.50	8.0	-3.5	PASS
Middle	914.25	3.13	8.0	-4.9	PASS
Highest	926.25	3.25	8.0	-4.8	PASS

**5.10.6. Plots**

Refer to plots # 37 - 42 in Exhibit 9 for measurement plots

**ULTRATECH GROUP OF LABS**

3000 Bristol Circle, Oakville, Ontario, Canada L6H 6G4

Tel. #: 905-829-1570, Fax. #: 905-829-8050, Email: [vhk.ultratech@sympatico.ca](mailto:vhk.ultratech@sympatico.ca), Website: <http://www.ultratech-labs.com>

File #: PAN3-FTX  
 July 18, 2000

- Assessed by ITI (UK) Competent Body, NVLAP (USA) Accreditation Body & ACA/AUSTEL (Australia), VCCI (Japan)
- Accredited by Industry Canada (Canada) under ACC-LAB (Europe/Canada MRA and APEC/Canada MRA)
- Recognized/Listed by FCC (USA)
- All test results contained in this engineering test report are traceable to National Institute of Standards and Technology (NIST)

**5.11. PROCESSING GAIN OF A DIRECT SEQUENCE SPREAD SPECTRUM, FCC CFR  
47, PARA. 15.247(e)**

**Processing Gain Measurement:  
KX-TD7895**

**July 04, 2000**

**Tadashi Yoshinaga**

**Telecom Division, Network Engineering Department**

---

**ULTRATECH GROUP OF LABS**

3000 Bristol Circle, Oakville, Ontario, Canada L6H 6G4

Tel. #: 905-829-1570, Fax. #: 905-829-8050, Email: [vhk.ultratech@sympatico.ca](mailto:vhk.ultratech@sympatico.ca), Website: <http://www.ultratech-labs.com>

File #: PAN3-FTX

July 18, 2000

- Assessed by ITI (UK) Competent Body, NVLAP (USA) Accreditation Body & ACA/AUSTEL (Australia), VCCI (Japan)
- Accredited by Industry Canada (Canada) under ACC-LAB (Europe/Canada MRA and APEC/Canada MRA)
- Recognized/Listed by FCC (USA)
- *All test results contained in this engineering test report are traceable to National Institute of Standards and Technology (NIST)*

## I. Requirements

According to the FCC requirement 15.247 for direct sequence spread spectrum systems, the minimum processing gain is 10 dB. The CW jamming method was used to determine the KX-TD7895 processing gain. The processing gain was calculated using the following equation:

$$G_p = S/I + J/S + L_{sys} \quad \text{where:}$$

$G_p$  = Processing Gain

$S/I$  = Signal to noise required for a given error probability. In this case  $1 \times 10^{-4}$  was used.

$J/S$  = Jammer to signal ratio required to produce given error probability.

$L_{sys}$  = System loss to due non ideal performance. Maximum allowed by the FCC is **2.0 dB**.

The  $S/I$  ratio was determined to be **11.0 dB** according to Jakes "Microwave Mobile Communications". Page 229 indicates the relevant curve showing error probability Vs  $S/I$  for a non-coherent FM system with a peak deviation equal to .35 of the modulation frequency:

$$F_d = .35 F_s.$$

Given a minimum processing gain of 10 dB, the minimum allowable  $J/S$  ratio is -3.0 dB.

## II. Test Setup

The processing gain was measured using the test setup shown in Figure 1:

The following test equipment was used for this setup:

- KX-TD7895 Equipment under test .
- Dummy Set: Used KX-TD7895 Evaluation set
- Hewlett Packard ESG D3000A Signal Generator (for desire signal )
- Hewlett Packard ESG D3000A Signal Generator (for jamming signal)
- Anritsu MA1612 Four port junction pad (insertion loss 15dB)
- Hewlett Packard 908A 50ohm terminator.
- Japan Radio Co Ltd.(JRC) MJZ-940 TDMA Error Ratio Measuring Equipment (BER tester)
- Semiflex SMA cables

The Dummy Set was set up at the middle channel 915.0 MHz. The KX-TD7895 base band 3dB bandwidth is less than 1.0 MHz; therefore, the signal generator was used to inject a C / W jammer from 914.0 MHz to 916.0 MHz in 50 kHz increments. The DUT received input power was set at -50 dBm. The jammer power was adjusted to achieve a bit error rate of  $1 \times 10^{-4}$  at each jammer frequency. The jammer power was recorded and the processing gain calculated for each jammer frequency from 914.0 MHz to 916.0 MHz.

## III. Test Results

The processing gain Vs jammer frequency is shown in Figure 2 and Figure 3 :

---

### ULTRATECH GROUP OF LABS

3000 Bristol Circle, Oakville, Ontario, Canada L6H 6G4

Tel. #: 905-829-1570, Fax. #: 905-829-8050, Email: [vhk.ultratech@sympatico.ca](mailto:vhk.ultratech@sympatico.ca), Website: <http://www.ultratech-labs.com>

File #: PAN3-FTX

July 18, 2000

- Assessed by ITI (UK) Competent Body, NVLAP (USA) Accreditation Body & ACA/AUSTEL (Australia), VCCI (Japan)
- Accredited by Industry Canada (Canada) under ACC-LAB (Europe/Canada MRA and APEC/Canada MRA)
- Recognized/Listed by FCC (USA)
- *All test results contained in this engineering test report are traceable to National Institute of Standards and Technology (NIST)*

Test Results

**KX-TD7895 Processing Gain Test Results**

Kyushu Matsushita Electric Co.,Ltd  
 Telecom Division ,Network Engineering Department  
 T.Yoshinaga

	Portable Uni	Base Unit
f - (k	D/U Ratio (dB)	D/U Ratio (dB)
1000	8.9	9.2
950	6.7	7.5
900	4.5	4.9
850	2.5	1.2
800	0.6	0.6
750	-0.4	0.5
700	-2.0	-1.3
650	-1.5	-1.2
600	-1.7	-2.2
550	-2.1	-1.8
500	-2.0	-2.1
450	-1.3	-1.1
400	-1.1	-1.0
350	-0.6	-0.6
300	-0.4	-0.5
250	-0.2	-0.6
200	-0.4	0.2
150	-0.1	-0.8
100	0.0	-0.5
50	-1.2	-1.0
0	9.4	8.2
-50	0.0	-1.1
-100	0.5	-0.5
-150	-0.3	-0.6
-200	0.5	-0.1
-250	-0.4	-0.6
-300	-0.4	-0.8
-350	-0.3	-0.8
-400	-0.9	-1.3
-450	-0.7	-1.1
-500	-1.7	-1.9
-550	-1.2	-1.9
-600	-1.6	-2.5
-650	-2.1	-2.5
-700	-1.8	-2.8
-750	-0.4	-0.9
-800	-1.3	0.1
-850	3.3	0.8
-900	5.2	4.0
-950	7.4	6.3
-1000	8.6	7.9

D/U Ratio = (Desire Signal) / (Undesired Signal) Ratio

 = worst 20% points  
 These points are excluded.

**Mj Jamming Margin**

Mj(J/S ratio)	
Portable	-1.5dB
Base	-1.3dB

\*Mj level is worst value  
 after exclude worst 20% points.

**Process Gain**

$G_p = (S/N)_o + M_j + L_{sys}$

(S/N)<sub>o</sub> = 11dB

L<sub>sys</sub> = 2.0dB

M<sub>j</sub>: compare above table.

G <sub>p</sub> (Process Gain)		
Portable	11.5dB	(= -1.5 + 11 + 2)
Base	11.7dB	(= -1.3 + 11 + 2)

Figure 2: Test Results of Process Gain

**ULTRATECH GROUP OF LABS**

3000 Bristol Circle, Oakville, Ontario, Canada L6H 6G4

Tel. #: 905-829-1570, Fax. #: 905-829-8050, Email: [vhk.ultratech@sympatico.ca](mailto:vhk.ultratech@sympatico.ca), Website: <http://www.ultratech-labs.com>

File #: PAN3-FTX

July 18, 2000

- Assessed by ITI (UK) Competent Body, NVLAP (USA) Accreditation Body & ACA/AUSTEL (Australia), VCCI (Japan)
- Accredited by Industry Canada (Canada) under ACC-LAB (Europe/Canada MRA and APEC/Canada MRA)
- Recognized/Listed by FCC (USA)
- All test results contained in this engineering test report are traceable to National Institute of Standards and Technology (NIST)

Test Results

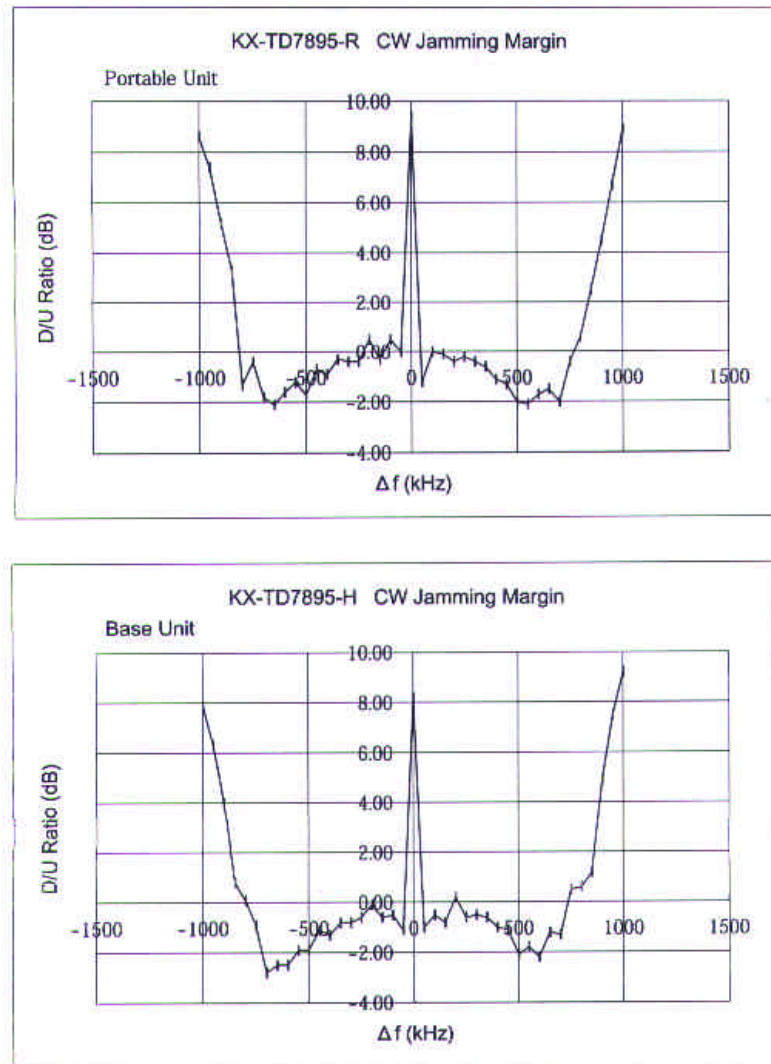

Figure 3: Test Results of Jamming Margin

**ULTRATECH GROUP OF LABS**

3000 Bristol Circle, Oakville, Ontario, Canada L6H 6G4

Tel. #: 905-829-1570, Fax. #: 905-829-8050, Email: [vhk.ultratech@sympatico.ca](mailto:vhk.ultratech@sympatico.ca), Website: <http://www.ultratech-labs.com>

File #: PAN3-FTX

July 18, 2000

- Assessed by ITI (UK) Competent Body, NVLAP (USA) Accreditation Body & ACA/AUSTEL (Australia), VCCI (Japan)
- Accredited by Industry Canada (Canada) under ACC-LAB (Europe/Canada MRA and APEC/Canada MRA)
- Recognized/Listed by FCC (USA)
- All test results contained in this engineering test report are traceable to National Institute of Standards and Technology (NIST)

$$G_p = (C/N)_0 + M_j + L_{sys}$$

$G_p$  = KX-TD7895 Process Gain  
 $(S/N)_0 = S/N$  ratio for keeping  $BER = 1 \times 10^{-4}$   
 $(S/N)_0$  is 11dB on this system.

$M_j$  = J/S ratio (CW Jamming margin method)  
 $L_{sys}$  = system loss ( $\leq 2.0$ dB)

1.

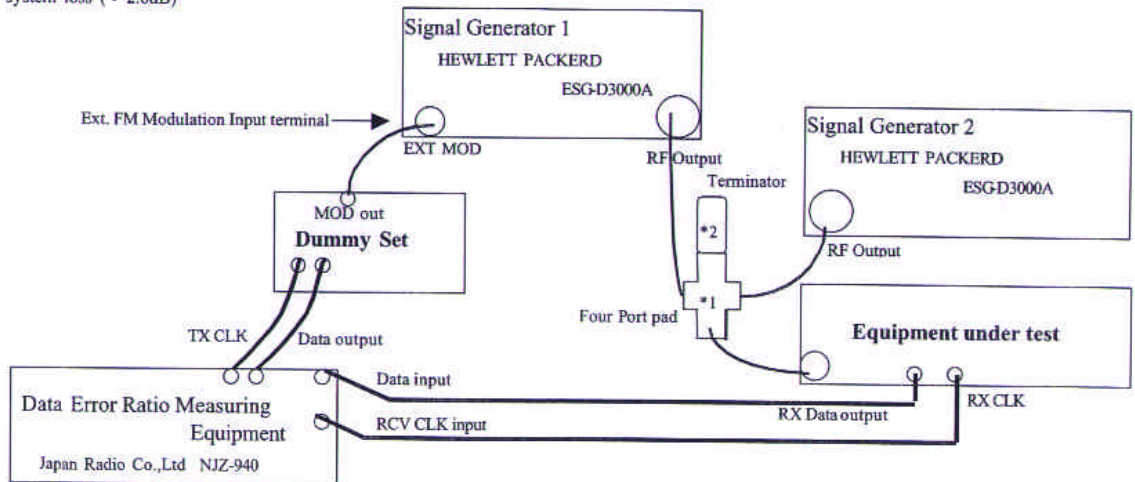

Figure 1: Processing Gain Test Setup

**ULTRATECH GROUP OF LABS**

3000 Bristol Circle, Oakville, Ontario, Canada L6H 6G4

Tel. #: 905-829-1570, Fax. #: 905-829-8050, Email: [vhk.ultratech@sympatico.ca](mailto:vhk.ultratech@sympatico.ca), Website: <http://www.ultratech-labs.com>

File #: PAN3-FTX

July 18, 2000

- Assessed by ITI (UK) Competent Body, NVLAP (USA) Accreditation Body & ACA/AUSTEL (Australia), VCCI (Japan)
- Accredited by Industry Canada (Canada) under ACC-LAB (Europe/Canada MRA and APEC/Canada MRA)
- Recognized/Listed by FCC (USA)
- All test results contained in this engineering test report are traceable to National Institute of Standards and Technology (NIST)

## EXHIBIT 6. MEASUREMENT UNCERTAINTY

The measurement uncertainties stated were calculated in accordance with the requirements of NIST Technical Note 1297 and NIS 81 (1994)

### 6.1. LINE CONDUCTED EMISSION MEASUREMENT UNCERTAINTY

CONTRIBUTION (Line Conducted)	PROBABILITY DISTRIBUTION	UNCERTAINTY (dB)	
		9-150 kHz	0.15-30 MHz
EMI Receiver specification	Rectangular	+1.5	+1.5
LISN coupling specification	Rectangular	+1.5	+1.5
Cable and Input Transient Limiter calibration	Normal (k=2)	+0.3	+0.5
Mismatch: Receiver VRC $\Gamma_1 = 0.03$ LISN VRC $\Gamma_R = 0.8$ (9 kHz) 0.2 (30 MHz) Uncertainty limits $20\text{Log}(1 \pm \Gamma_1 \Gamma_R)$	U-Shaped	+0.2	+0.3
System repeatability	Std. deviation	+0.2	+0.05
Repeatability of EUT	--	--	--
Combined standard uncertainty	Normal	+1.25	+1.30
Expanded uncertainty U	Normal (k=2)	+2.50	+2.60

Sample Calculation for Measurement Accuracy in 450 kHz to 30 MHz Band:

$$u_c(y) = \sqrt{\sum_{i=1}^m u_i^2(y)} = \pm \sqrt{(1.5^2 + 1.5^2)/3 + (0.5/2)^2 + (0.05/2)^2 + 0.35^2} = \pm 1.30 \text{ dB}$$

$$U = 2u_c(y) = \pm 2.6 \text{ dB}$$

#### ULTRATECH GROUP OF LABS

3000 Bristol Circle, Oakville, Ontario, Canada L6H 6G4

Tel. #: 905-829-1570, Fax. #: 905-829-8050, Email: [vhk.ultratech@sympatico.ca](mailto:vhk.ultratech@sympatico.ca), Website: <http://www.ultratech-labs.com>

File #: PAN3-FTX  
 July 18, 2000

- Assessed by ITI (UK) Competent Body, NVLAP (USA) Accreditation Body & ACA/AUSTEL (Australia), VCCI (Japan)
- Accredited by Industry Canada (Canada) under ACC-LAB (Europe/Canada MRA and APEC/Canada MRA)
- Recognized/Listed by FCC (USA)
- All test results contained in this engineering test report are traceable to National Institute of Standards and Technology (NIST)

## 6.2. RADIATED EMISSION MEASUREMENT UNCERTAINTY

CONTRIBUTION (Radiated Emissions)	PROBABILITY DISTRIBUTION	UNCERTAINTY (+ dB)	
		3 m	10 m
Antenna Factor Calibration	Normal (k=2)	+1.0	+1.0
Cable Loss Calibration	Normal (k=2)	+0.3	+0.5
EMI Receiver specification	Rectangular	+1.5	+1.5
Antenna Directivity	Rectangular	+0.5	+0.5
Antenna factor variation with height	Rectangular	+2.0	+0.5
Antenna phase center variation	Rectangular	0.0	+0.2
Antenna factor frequency interpolation	Rectangular	+0.25	+0.25
Measurement distance variation	Rectangular	+0.6	+0.4
Site imperfections	Rectangular	+2.0	+2.0
Mismatch: Receiver VRC $\Gamma_1 = 0.2$ Antenna VRC $\Gamma_R = 0.67(\text{Bi}) 0.3 (\text{Lp})$ Uncertainty limits $20\text{Log}(1+\Gamma_1\Gamma_R)$	U-Shaped	+1.1 -1.25	+0.5
System repeatability	Std. Deviation	+0.5	+0.5
Repeatability of EUT		-	-
Combined standard uncertainty	Normal	+2.19 / -2.21	+1.74 / -1.72
Expanded uncertainty U	Normal (k=2)	+4.38 / -4.42	+3.48 / -3.44

Calculation for maximum uncertainty when 3m biconical antenna including a factor of k=2 is used:

$$U = 2u_c(y) = 2x(+2.19) = +4.38 \text{ dB} \quad \text{And} \quad U = 2u_c(y) = 2x(-2.21) = -4.42 \text{ dB}$$

### ULTRATECH GROUP OF LABS

3000 Bristol Circle, Oakville, Ontario, Canada L6H 6G4

Tel. #: 905-829-1570, Fax. #: 905-829-8050, Email: [vhk.ultratech@sympatico.ca](mailto:vhk.ultratech@sympatico.ca), Website: <http://www.ultratech-labs.com>

File #: PAN3-FTX

July 18, 2000

- Assessed by ITI (UK) Competent Body, NVLAP (USA) Accreditation Body & ACA/AUSTEL (Australia), VCCI (Japan)
- Accredited by Industry Canada (Canada) under ACC-LAB (Europe/Canada MRA and APEC/Canada MRA)
- Recognized/Listed by FCC (USA)
- All test results contained in this engineering test report are traceable to National Institute of Standards and Technology (NIST)

## EXHIBIT 7. MEASUREMENT METHODS

### 7.1. GENERAL TEST CONDITIONS

The following test conditions shall be applied throughout the tests covered in this report.

#### 7.1.1. Normal temperature and humidity

- Normal temperature: +15°C to +35°C
- Relative Humidity: +20% to 75%

The actual values during tests shall be recorded in the test report.

#### 7.1.2. Normal power source

##### 7.1.2.1. Mains Voltage

The nominal test voltage of the equipment to be connected to mains shall be the nominal mains voltage which is the declared voltage or any of the declared voltages for which the equipment was designed.

The frequency of test power source corresponding to the AC mains shall be between 59 Hz and 61 Hz.

##### 7.1.2.2. Battery Power Source.

For operation from battery power sources, the nominal test voltage shall be as declared by the equipment manufacturer. This shall be recorded in the test report.

#### 7.1.3. Operating Condition of Equipment under Test

- All tests were carried out while the equipment operated at the following frequencies:
  - The lowest operating frequency,
  - The middle operating frequency and
  - The highest operating frequency
- Modulation were applied using the Test Data sequence
- The transmitter was operated at the highest output power, or in the case the equipment able to operate at more than one power level, at the lowest and highest output powers

---

### ULTRATECH GROUP OF LABS

3000 Bristol Circle, Oakville, Ontario, Canada L6H 6G4

Tel. #: 905-829-1570, Fax. #: 905-829-8050, Email: [vhk.ultratech@sympatico.ca](mailto:vhk.ultratech@sympatico.ca), Website: <http://www.ultratech-labs.com>

File #: PAN3-FTX  
July 18, 2000

- Assessed by ITI (UK) Competent Body, NVLAP (USA) Accreditation Body & ACA/AUSTEL (Australia), VCCI (Japan)
- Accredited by Industry Canada (Canada) under ACC-LAB (Europe/Canada MRA and APEC/Canada MRA)
- Recognized/Listed by FCC (USA)
- All test results contained in this engineering test report are traceable to National Institute of Standards and Technology (NIST)

## 7.2. METHOD OF MEASUREMENTS - AC MAINS CONDUCTED EMISSIONS

- AC Mains conducted emissions measurements were performed in accordance with the standard against appropriate limits for each detector function.
- The test was performed in the shielded room, 16'(L) by 16'(W) by 12'(H).
- The test was performed were made over the frequency range from 450 kHz to 30 MHz to determine the line-to-ground radio noise voltage which was conducted from the EUT power-input terminals that were directly connected to a public power network.
- The EUT normally received power from another device that connects to the public utility ac power lines, measurements would be made on that device with the EUT in operation to ensure that the device continues to comply with the appropriate limits while providing the EUT with power.
- If the EUT operates only from internal or dedicated batteries, with no provisions for connection to the public utility ac power lines, AC Mains conducted measurements are not required.
- Table-top devices were placed on a platform of nominal size 1 m by 1.5m raised 80 cm above the conducting ground plane.
- The EUT current-carrying power lead, except the ground (safety) lead, was individually connected through a LISN to the power source. All unused 50-Ohm connectors of the LISN was terminated in 50-ohm when not connected to the measuring instruments.
- The line cord of the EUT connected to one LISN which was connected to the measuring instrument. Those power cords for the units of devices not under measurement were connected to a separate multiple ac outlet. Drawings and photographs of typically conducted emission test setups were shown in the Test Report. Each current-carrying conductor of the EUT shall be individually tested.
- The EUT was normally operated with a ground (safety) connection, the EUT was connected to the ground at the LISN through a conductor provided in the lead from the ac power mains to the LISN.
- The excess length of the power cord was folded back and forth in an 8-shape on a wooden strip with a vertical prong located on the top of the LISN case.
- The EUT was set-up in its typical configuration and operated in its various modes as described in 3.2 of the test report.
- A preliminary scan was made by using spectrum analyzer system with the detector function set to PEAK mode (9 KHz RBW, VBW > RBW), frequency span 450 kHz to 30 MHz.
- The maximum conducted emission for a given mode of operation was found by using the following step-by-step procedure:
  - Step1. Monitor the frequency range of interest at a fixed EUT azimuth.
  - Step2. Manipulate the system cables and peripheral devices to produce highest amplitude signal relative to the limit. Note the amplitude and frequency of the suspect signal.
  - Step3. The effects of various modes of operation is examined. This is done by varying equipment operation modes as step 2 is being performed.
  - Step4. After completing step 1 through 3, record EUT and peripheral device configuration, mode of operation, cable configuration, signal levels and frequencies for final test.
- Each highest signal level at the maximized test configuration was zoomed in a small frequency span on the spectrum analyzer's display (the manipulation of cables and peripheral devices and EUT operation modes might have to be repeated to obtain the highest signal level with the spectrum analyzer set to PEAK detector mode 10 KHz RBW and VBW > RBW). The spectrum analyzer was then set to CISPR QUASI-PEAK detector mode (9 KHz RBW, 1 MHz VBW) and AVERAGE detector mode (10 kHz RBW, 1 Hz VBW). The final highest RF signal levels and frequencies were record.

---

### ULTRATECH GROUP OF LABS

3000 Bristol Circle, Oakville, Ontario, Canada L6H 6G4

Tel. #: 905-829-1570, Fax. #: 905-829-8050, Email: [vhk.ultratech@sympatico.ca](mailto:vhk.ultratech@sympatico.ca), Website: <http://www.ultratech-labs.com>

File #: PAN3-FTX  
July 18, 2000

- Assessed by ITI (UK) Competent Body, NVLAP (USA) Accreditation Body & ACA/AUSTEL (Australia), VCCI (Japan)
- Accredited by Industry Canada (Canada) under ACC-LAB (Europe/Canada MRA and APEC/Canada MRA)
- Recognized/Listed by FCC (USA)
- *All test results contained in this engineering test report are traceable to National Institute of Standards and Technology (NIST)*

- **Broad-band ac Powerline conducted emissions:-** If the EUT exhibits ac Powerline conducted emissions that exceed the limit with the instrument set to the quasi-peak mode, then measurements should be made in the average mode. If the amplitude measured in the quasi-peak mode is at least 6 dB higher than the amplitude measured in the average mode, the level measured in quasi peak mode may be reduced by 13 dB before comparing it to the limit.

### 7.3. EFFECTIVE RADIATED POWER

- The following shall be applied to the combination(s) of the radio device and its intended antenna(e).
- If the RF level is user adjustable, all measurements shall be made with the highest power level available to the user for that combination.
- The following method of measurement shall apply to both conducted and radiated measurements.
- The radiated measurements are performed at the Ultratech Calibrated Open Field Test Site.
- The measurement shall be performed using normal operation of the equipment with modulation.

Test procedure shall be as follows:

#### Step 1: Duty Cycle measurements

- Using a spectrum analyzer with the frequency span set to 0 Hz and the sweep time set at a suitable value to capture the envelope peaks and the duty cycle of the transmitter output signal;
- The duty cycle of the transmitter,  $x = \text{Tx on} / (\text{Tx on} + \text{Tx off})$  with  $0 < x < 1$ , is measure and recorded in the test report. For the purpose of testing, the equipment shall be operated with a duty cycle that is equal or more than 0.1.

#### Step 2: Calculation of Peak and Average EIRP

- The peak output power of the transmitter shall be determined using a wideband, calibrated RF Peak Power Meter with the power sensor with an integration period that exceeds the repetition period of the transmitter by a factor 5 or more. The observed value shall be recorded as “P” (in dBm);
- The Average EIRP. shall be calculated from the above measured power output “A”, the observed duty cycle x, and the applicable antenna assembly gain “G” in dBi, according to the formula:

$$\text{Peak EIRP} = P + G$$

$$\text{Average EIRP} = \text{Peak EIRP} + 10\log(1/x)$$

Figure 1.

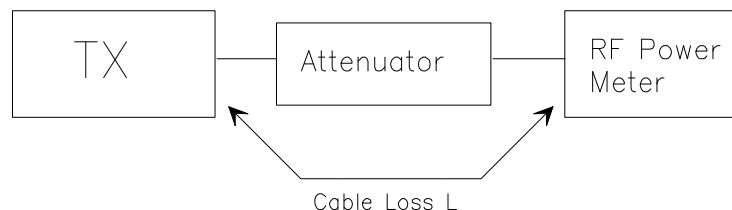

#### Step 3: Substitution Method. See Figure 2

- (a) The measurements was performed in the absence of modulation (un-modulated)
- (b) Test was performed at listed 3m open area test site (listed with FCC, IC, ITI, NVLAP, ACA & VCCI).
- (c) The transmitter under test was placed at the specified height on a non-conducting turntable (80 cm height)
- (d) The dipole test antenna was used and tuned to the transmitter carrier frequency.
- (e) The spectrum analyzer was tuned to transmitter carrier frequency. The test antenna was lowered or raised from 1 to 4 meters until the maximum signal level was detected.
- (f) The transmitter was rotated through 360° about a vertical axis until a higher maximum signal was received.

### ULTRATECH GROUP OF LABS

3000 Bristol Circle, Oakville, Ontario, Canada L6H 6G4

Tel. #: 905-829-1570, Fax. #: 905-829-8050, Email: [vhk.ultratech@sympatico.ca](mailto:vhk.ultratech@sympatico.ca), Website: <http://www.ultratech-labs.com>

File #: PAN3-FTX  
July 18, 2000

- Assessed by ITI (UK) Competent Body, NVLAP (USA) Accreditation Body & ACA/AUSTEL (Australia), VCCI (Japan)
- Accredited by Industry Canada (Canada) under ACC-LAB (Europe/Canada MRA and APEC/Canada MRA)
- Recognized/Listed by FCC (USA)
- All test results contained in this engineering test report are traceable to National Institute of Standards and Technology (NIST)

- (g) The test antenna was lowered or raised again from 1 to 4 meters until a maximum was obtained. This level was recorded.
- (h) The substitution dipole antenna and the signal generator replaced the transmitter and antenna under test in the same position, and the substitution dipole antenna was placed in vertical polarization. The test dipole antenna was lowered or raised as necessary to ensure that the maximum signal is still received.
- (i) The input signal to the substitution antenna was adjusted in level until an equal or a known related level to that detected from the transmitter was obtained in the test receiver. The maximum carrier radiated power is equal to the power supply by the generator.
- (j) The substitution antenna gain and cable loss were added to the signal generator level for the corrected ERP level.
- (k) Repeat steps (c) to (j) with the substitution antenna oriented in horizontal polarization.
- (l) Actual gain of the EUT's antenna is the difference of the measured ERP and measured RF power at the RF port. Correct the antenna gain if necessary.

Figure 2

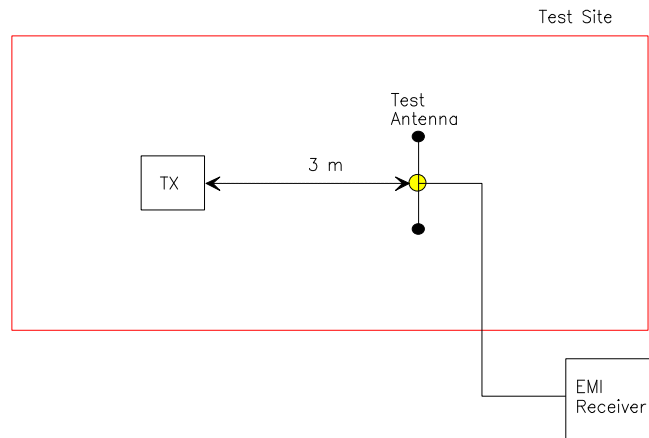
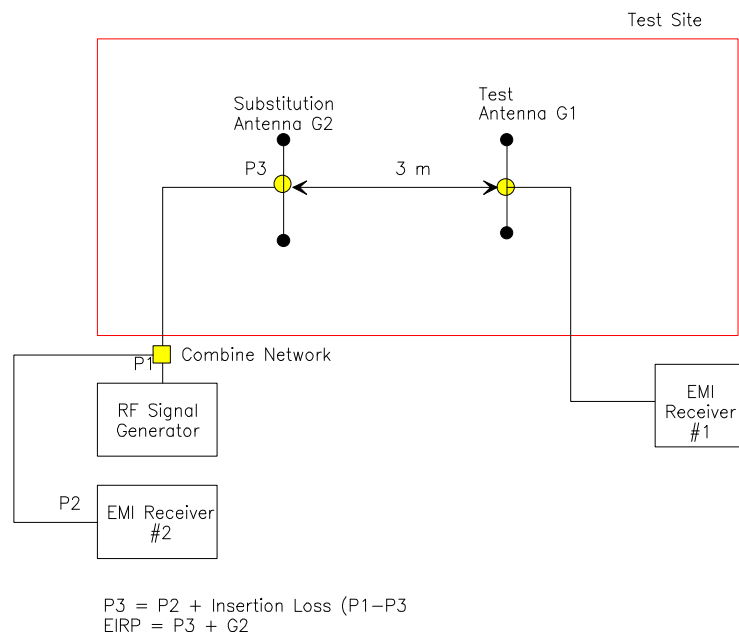

Figure 3



**ULTRATECH GROUP OF LABS**

3000 Bristol Circle, Oakville, Ontario, Canada L6H 6G4

Tel. #: 905-829-1570, Fax. #: 905-829-8050, Email: [vhk.ultratech@sympatico.ca](mailto:vhk.ultratech@sympatico.ca), Website: <http://www.ultratech-labs.com>

File #: PAN3-FTX  
 July 18, 2000

- Assessed by ITI (UK) Competent Body, NVLAP (USA) Accreditation Body & ACA/AUSTEL (Australia), VCCI (Japan)
- Accredited by Industry Canada (Canada) under ACC-LAB (Europe/Canada MRA and APEC/Canada MRA)
- Recognized/Listed by FCC (USA)
- All test results contained in this engineering test report are traceable to National Institute of Standards and Technology (NIST)

## 7.4. SPURIOUS EMISSIONS (CONDUCTED & RADIATED)

For both conducted and radiated measurements, the spurious emissions were scanned from the lowest frequency generated by the EUT or 10 MHz whichever is lower to 10<sup>th</sup> harmonic of the highest frequency generated by the EUT.

### 7.4.1. Spurious Emissions (Conducted)

- The radio was connected to the measuring equipment via a suitable attenuator.
- The spectrum analyzer were used and set as follows:
  - Resolution BW: 100 kHz
  - Video BW: same or greater
  - Detector Mode: Positive Peak
  - Averaging: Off
  - Span: 100 MHz
  - Amplitude: Adjust for middle of the instrument's range
  - Sweep Time: Auto

### 7.4.2. Spurious Emissions (Radiated)

- The radiated emission measurements were performed at the UltraTech's 3 Meter Open Field Test Site (OFTS) situated in the Town of Oakville, province of Ontario. The Attenuation Characteristics of OFTS have been filed to FCC, Industry Canada, ACA/Austel, NVLap and ITI.
- Radiated emissions measurements were made using the following test instruments:
  1. Calibrated EMCO BiconiLog antenna in the frequency range from 30 MHz to 2000 MHz.
  2. Calibrated Emco Horn antennas in the frequency range above 1000 MHz (1GHz - 40 GHz).
  3. Calibrated Advantest spectrum analyzer and pre-selector were used. The spectrum analyzer would be used as follows:

For frequencies below 1 GHz:

- Resolution BW: 100 kHz
- Video BW: same or greater
- Detector Mode: Positive Peak
- Averaging: Off
- Span: 100 MHz
- Amplitude: Adjust for middle of the instrument's range
- Sweep Time: Auto

For frequencies above 1 GHz:

- Resolution BW: 1 MHz
- Video BW: same or greater
- Detector Mode: Positive Peak
- Averaging: Off
- Span: 500 MHz
- Amplitude: Adjust for middle of the instrument's range
- Sweep Time: Auto

---

## ULTRATECH GROUP OF LABS

3000 Bristol Circle, Oakville, Ontario, Canada L6H 6G4

Tel. #: 905-829-1570, Fax. #: 905-829-8050, Email: [vhk.ultratech@sympatico.ca](mailto:vhk.ultratech@sympatico.ca), Website: <http://www.ultratech-labs.com>

File #: PAN3-FTX  
July 18, 2000

- Assessed by ITI (UK) Competent Body, NVLAP (USA) Accreditation Body & ACA/AUSTEL (Australia), VCCI (Japan)
- Accredited by Industry Canada (Canada) under ACC-LAB (Europe/Canada MRA and APEC/Canada MRA)
- Recognized/Listed by FCC (USA)
- *All test results contained in this engineering test report are traceable to National Institute of Standards and Technology (NIST)*

- The frequencies of emissions was first detected. Then the amplitude of the emissions was measured at the specified measurement distance using required antenna height, polarization, and detector characteristics.
- During this process, cables and peripheral devices were manipulated within the range of likely configuration.
- For each mode of operation required to be tested, the frequency spectrum was monitored. Variations in antenna heights (from 1 meter to 4 meters above the ground plane), antenna polarization (horizontal plane and vertical plane), cable placement and peripheral placement were explored to produce the highest amplitude signal relative to the limit.

The maximum radiated emission for a given mode of operation was found by using the following step-by-step procedure:

- Step1: Monitor the frequency range of interest at a fixed antenna height and EUT azimuth.
- Step2: Manipulate the system cables to produce highest amplitude signal relative to the limit. Note the amplitude and frequency of the suspect signal.
- Step3: Rotate the EUT 360 degrees to maximize the suspected highest amplitude signal. If the signal or another at a different frequency is observed to exceed the previously noted highest amplitude signal by 1 dB or more, go back to the azimuth and repeat Step 2. Otherwise, orient the EUT azimuth to repeat the highest amplitude observation and proceed.
- Step4: Move the antenna over its full allowable range of travel (1 to 4 meters) to maximize the suspected highest amplitude signal. If the signal or another at a different frequency is observed to exceed the previously noted highest amplitude signal by 1 dB or more, return to Step 2 with the highest amplitude observation and proceed.
- Step5: Change the polarization of the antenna and repeat Step 2 through 4. Compare the resulting suspected highest amplitude signal with that found for the other polarization. Select and note the higher of the two signals. This signal is termed the highest observed signal with respect to the limit for this EUT operational mode.
- Step6: The effects of various modes of operation is examined. This is done by varying the equipment modes as steps 2 through 5 are being performed.
- Step7: After completing steps 1 through 6, record the final highest emission level, frequency, antenna polarization and detector mode of the measuring instrument.

---

**ULTRATECH GROUP OF LABS**

3000 Bristol Circle, Oakville, Ontario, Canada L6H 6G4

Tel. #: 905-829-1570, Fax. #: 905-829-8050, Email: [vhk.ultratech@sympatico.ca](mailto:vhk.ultratech@sympatico.ca), Website: <http://www.ultratech-labs.com>

File #: PAN3-FTX

July 18, 2000

- Assessed by ITI (UK) Competent Body, NVLAP (USA) Accreditation Body & ACA/AUSTEL (Australia), VCCI (Japan)
- Accredited by Industry Canada (Canada) under ACC-LAB (Europe/Canada MRA and APEC/Canada MRA)
- Recognized/Listed by FCC (USA)
- *All test results contained in this engineering test report are traceable to National Institute of Standards and Technology (NIST)*

**Calculation of Field Strength:**

The field strength is calculated by adding the calibrated antenna factor and cable factor, and subtracting the Amplifier gain (if any) from the measured reading. The basic equation with a sample calculation is as follows:

$$FS = RA + AF + CF - AG$$

Where FS = Field Strength  
RA = Receiver/Analyzer Reading  
AF = Antenna Factor  
CF = Cable Attenuation Factor  
AG = Amplifier Gain

**Example:** If a receiver reading of 60.0 dBuV is obtained, the antenna factor of 7.0 dB/m and cable factor of 1.0 dB are added, and the amplifier gain of 30 dB is subtracted. The actual field strength will be:.

$$\text{Field Level} = 60 + 7.0 + 1.0 - 30 = 38.0 \text{ dBuV/m.}$$

$$\text{Field Level} = 10^{(38/20)} = 79.43 \text{ uV/m.}$$

**7.5. TRANSMITTED POWER DENSITY OF A DSSS SYSTEM**

- The radio was connected to the measuring equipment via a suitable attenuator.
- Locate and zoom in on emission peak(s) within the passband
- The spectrum analyzer were used and set as follows:
  - Resolution BW: 3 kHz
  - Video BW: same or greater
  - Detector Mode: Normal
  - Averaging: Off
  - Span: 3 MHz
  - Amplitude: Adjust for middle of the instrument's range
  - Sweep Time: 1000 seconds
- Locate and zoom in on emission peak(s) within the passband. Set RBW = 3 KHz, VBW ≥ RBW, Sweep = SPAN/3 KHz. For example, a span of 1.5 MHz, the sweep should be  $1.6 \times 10^6 / 3.0 \times 10^3 = 500$  seconds. The measured peak level must be no greater than +8 dBm.
- For devices with spectrum line spacing greater than 3 KHz no change is required.
- For devices with spectrum line spacing equal to or less than 3 KHz, the resolution bandwidth must be reduced below 3 KHz until the individual lines in the spectrum are resolved. The measurement data must then be normalized to 3 KHz by summing the power of all the individual spectral lines within 3 KHz band (in linear power units) to determine compliance.
- If the spectrum line spacing cannot be resolved on the available spectrum analyzer, the noise density function on most modern conventional spectrum analyzer will directly measure the noise density normalized to 1 Hz noise power bandwidth. Add 30 dB for correction to 3 KHz.
- Should all the above fail or any controversy develop regarding accuracy of measurement, the Laboratory will use HP 89440A Vector Signal Analyzer for final measurement unless a clear showing can be made for a further alternate.

**ULTRATECH GROUP OF LABS**

3000 Bristol Circle, Oakville, Ontario, Canada L6H 6G4

Tel. #: 905-829-1570, Fax. #: 905-829-8050, Email: [vhk.ultratech@sympatico.ca](mailto:vhk.ultratech@sympatico.ca), Website: <http://www.ultratech-labs.com>

File #: PAN3-FTX  
July 18, 2000

- Assessed by ITI (UK) Competent Body, NVLAP (USA) Accreditation Body & ACA/AUSTEL (Australia), VCCI (Japan)
- Accredited by Industry Canada (Canada) under ACC-LAB (Europe/Canada MRA and APEC/Canada MRA)
- Recognized/Listed by FCC (USA)
- All test results contained in this engineering test report are traceable to National Institute of Standards and Technology (NIST)

## EXHIBIT 8. TEST SETUP PHOTOGRAPHS

---

### ULTRATECH GROUP OF LABS

3000 Bristol Circle, Oakville, Ontario, Canada L6H 6G4

Tel. #: 905-829-1570, Fax. #: 905-829-8050, Email: [vhk.ultratech@sympatico.ca](mailto:vhk.ultratech@sympatico.ca), Website: <http://www.ultratech-labs.com>

File #: PAN3-FTX  
July 18, 2000

- Assessed by ITI (UK) Competent Body, NVLAP (USA) Accreditation Body & ACA/AUSTEL (Australia), VCCI (Japan)
- Accredited by Industry Canada (Canada) under ACC-LAB (Europe/Canada MRA and APEC/Canada MRA)
- Recognized/Listed by FCC (USA)
- *All test results contained in this engineering test report are traceable to National Institute of Standards and Technology (NIST)*

## EXHIBIT 9. TEST DATA PLOTS

---

### ULTRATECH GROUP OF LABS

3000 Bristol Circle, Oakville, Ontario, Canada L6H 6G4

Tel. #: 905-829-1570, Fax. #: 905-829-8050, Email: [vhk.ultratech@sympatico.ca](mailto:vhk.ultratech@sympatico.ca), Website: <http://www.ultratech-labs.com>

File #: PAN3-FTX

July 18, 2000

- Assessed by ITI (UK) Competent Body, NVLAP (USA) Accreditation Body & ACA/AUSTEL (Australia), VCCI (Japan)
- Accredited by Industry Canada (Canada) under ACC-LAB (Europe/Canada MRA and APEC/Canada MRA)
- Recognized/Listed by FCC (USA)
- *All test results contained in this engineering test report are traceable to National Institute of Standards and Technology (NIST)*