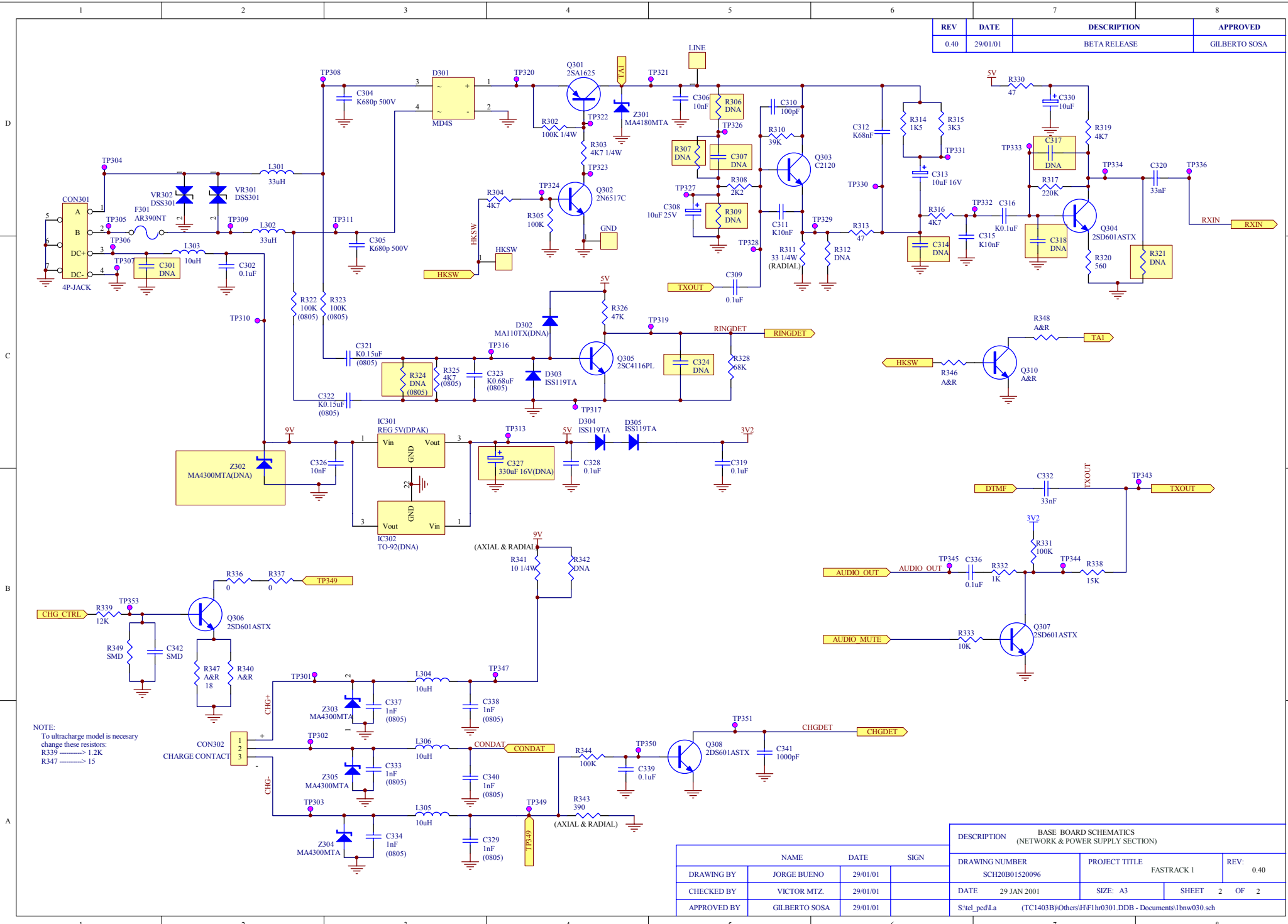

EXHIBIT F-1



REV	DATE	DESCRIPTION	APPROVED
0.40	29/01/01	BETA RELEASE	GILBERTO SOSA

NOTE:
To ultracharge model is necessary
change these resistors:
R339 → 1.2K
R347 → 15

DESCRIPTION				BASE BOARD SCHEMATICS (NETWORK & POWER SUPPLY SECTION)			
NAME	DATE	SIGN	DRAWING NUMBER	PROJECT TITLE	REV:		
JORGE BUENO	29/01/01		SCH20B01520096	FASTRACK 1	0.40		
VICTOR MITZ	29/01/01		DATE 29 JAN 2001	SIZE: A3	SHEET 2	OF 2	
GILBERTO SOSA	29/01/01		S:\tel_ped\La (TC1403B)\Others\HF1hr0301.DDB - Documents\lbnw030.sch				

EXHIBIT F-2

REV	DATE	DESCRIPTION	APPROVED
0.40	29/01/01	BETA RELEASE	GILBERTO SOSA

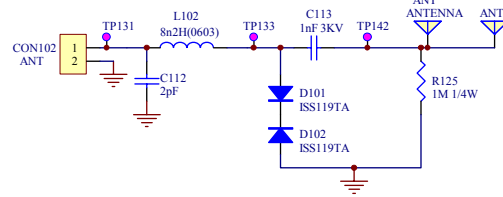
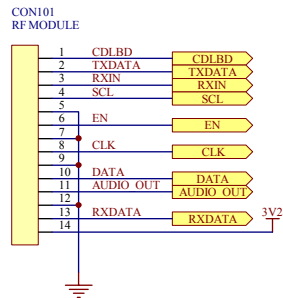
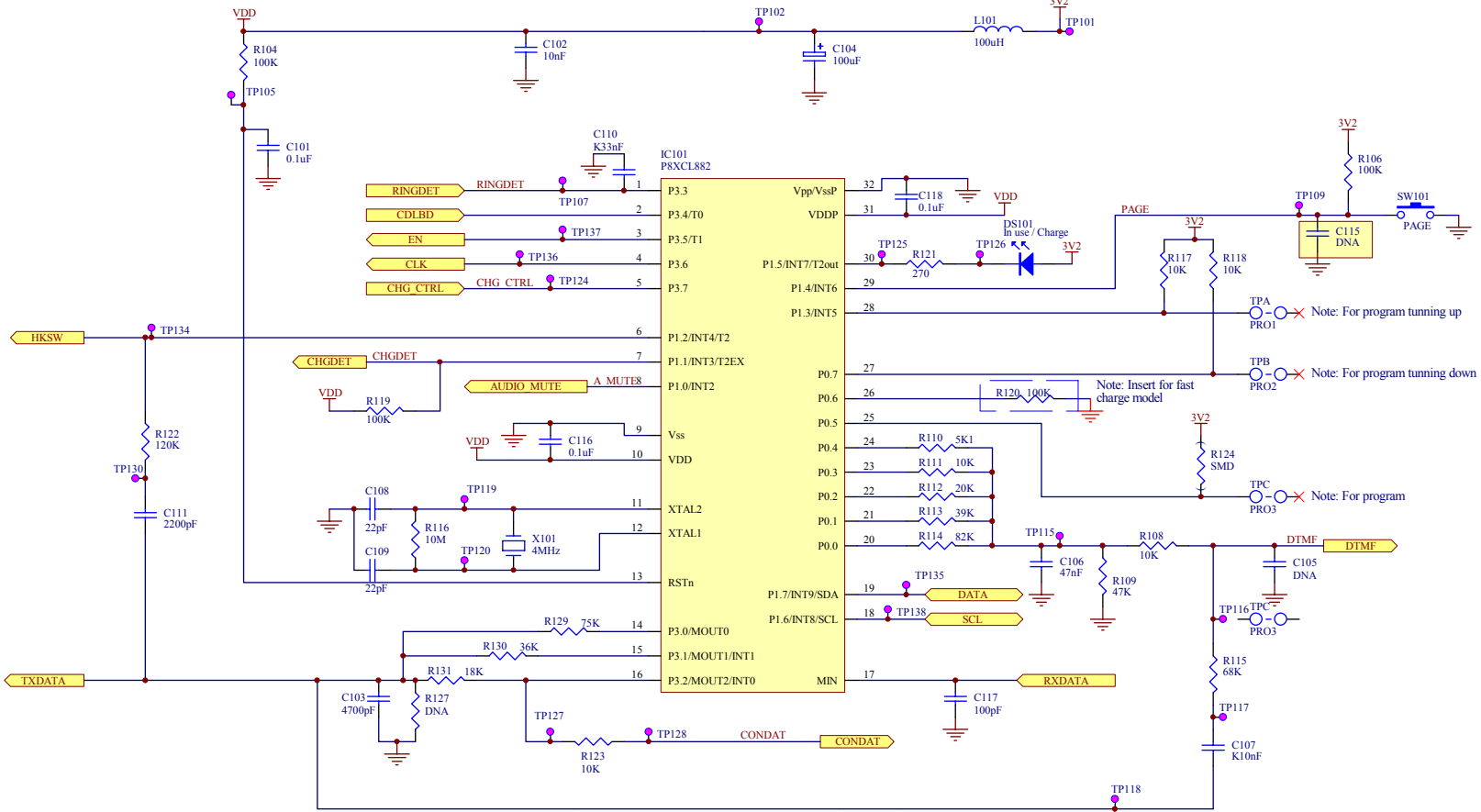

NAME			DATE			SIGN					
DRAWING BY	JORGE BUENO	29/01/01				DRAWING NUMBER	SCH20B01520096	PROJECT TITLE	FASTRACK 1	REV:	0.40
CHECKED BY	VICTOR MITZ	29/01/01				DATE	29 JAN 2001	SIZE:	A3	SHEET	1 OF 2
APPROVED BY	GILBERTO SOSA	29/01/01				S:\tel_ped\La (TC1403B)\Others\HF1hr0301.DDB - Documents\lup030.sch					

DESCRIPTION: BASE BOARD SCHEMATICS (MICROPROCESSOR SECTION)

EXHIBIT F-3

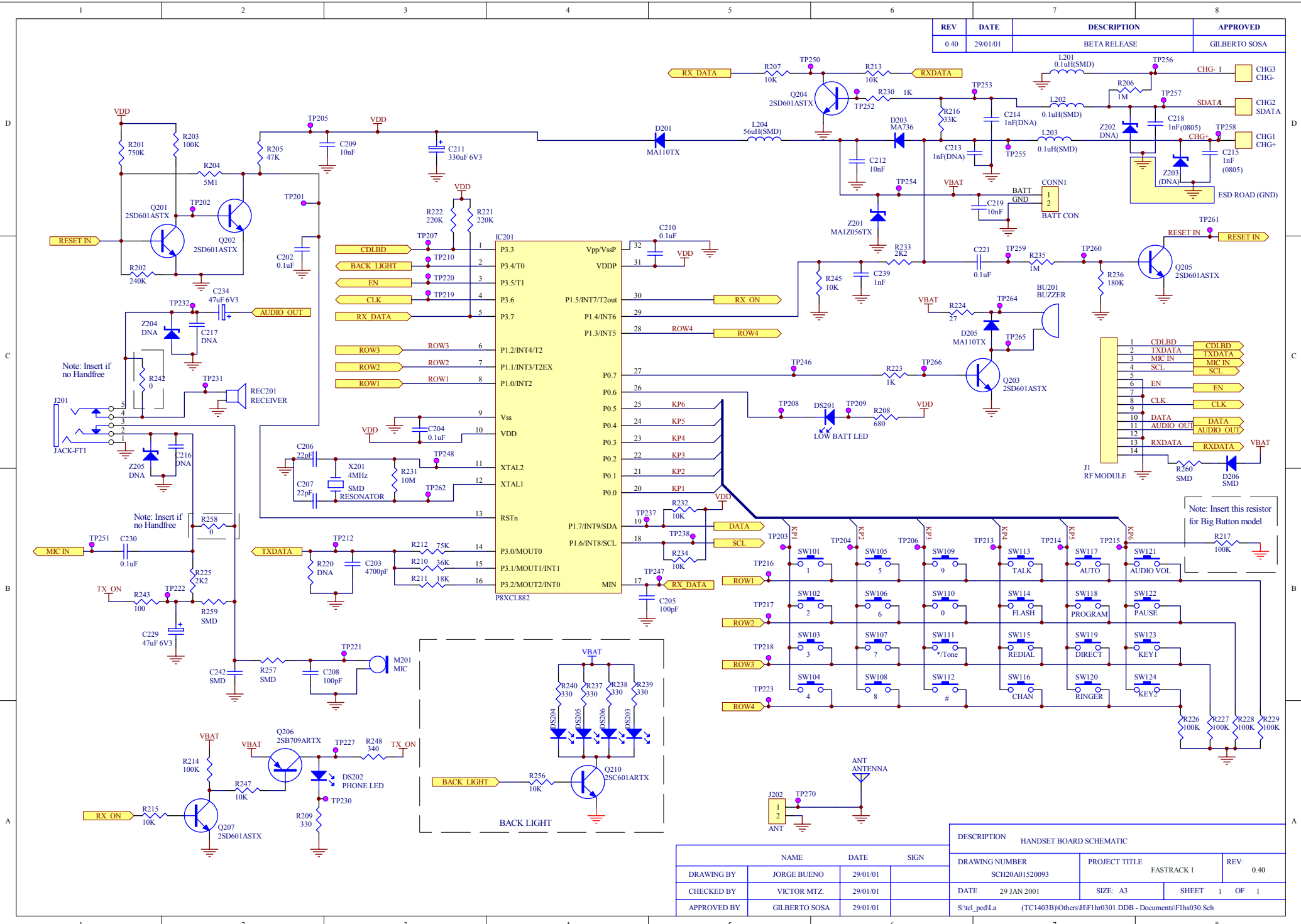

REV	DATE	DESCRIPTION	APPROVED
0.40	29/01/01	BETA RELEASE	GILBERTO SOSA

DESCRIPTION				HANDSET BOARD SCHEMATIC			
NAME	DATE	SIGN	DRAWING NUMBER	PROJECT TITLE	REV:		
DRAWING BY	JORGE BUENO	29/01/01	SCH20A01520093	FASTRACK 1	0.40		
CHECKED BY	VICTOR MITZ	29/01/01	DATE	29 JAN 2001	SIZE: A3	SHEET	1 OF 1
APPROVED BY	GILBERTO SOSA	29/01/01	S:\tel_ped\La (TC1403B)\Others\HF1hr0301.DDB - Documents\F1hs030.Sch				

