



www.nemko.com

Nemko Canada Inc., 303 River Road, R.R. 5, Ottawa, Ontario, Canada, K1V 1H2

Report Number: 126976-1R1TRFEMC

Product Marketing Name: DECT 6.0 8-Channel IP Cell Station Unit

Test Specification:

- FCC 47 CFR Part 15, Subpart B – Verification (USA)
- ICES-003 Issue 4 February 2004 (Canada)

Reviewed by:

Signature
Andrey Adelberg, EMC/Wireless Specialist

May 19, 2009

Date

Tested by: David Duchesne, Senior EMC Specialist

Nemko Canada Inc. authorizes the applicant to reproduce this report provided it is reproduced in its entirety and for use by the company's employees only. Any use which a third party makes of this report, or any reliance on or decisions to be made based on it, are the responsibility of such third parties.

Nemko Canada Inc. accepts no responsibility for damages, if any suffered by any third party as a result of decisions made or actions based on this report.

This report shall not be reproduced except in full without the written approval of the testing laboratory.



Nemko Canada Inc., a testing laboratory, is accredited by the Standards Council of Canada.
The tests included in this report are within the scope of this accreditation.



Table of Contents

Declaratory Statements.....	3
Statement of Compliance.....	4
Measurement Uncertainty.....	5
Lab Environmental Conditions.....	5
Engineering Considerations.....	5
General Information Regarding the Equipment Under Test (EUT).....	6
Equipment Configuration.....	6
Radiated Disturbance.....	7
Conducted Disturbance at Mains Port.....	10



Nemko Canada Inc.,
303 River Road, R.R. 5, Ottawa, Ontario, Canada, K1V 1H2

Report No: 127679-1R1TRFEMC

Declaratory Statements

Product Marketing Name: DECT 6.0 8-Channel IP Cell Station Unit

Model #: KX-NCP0158

Trademark: **Panasonic**

Serial #: 9AAVA000100

Applicant:
PANASONIC Canada Inc.
5770 Ambler Drive
Mississauga, ON, Canada
L4W 2T3

Manufacturer:
Panasonic Communications Co., Ltd.
1-62, 4-chome, Minoshima, Hakata-ku
Fukuoka, 812-8531
Japan

Product Background details

- | | |
|---|--|
| <input checked="" type="checkbox"/> New Product | <input type="checkbox"/> Engineering Changes |
| <input type="checkbox"/> Configuration Change | <input type="checkbox"/> Product Audit |
| <input type="checkbox"/> Other | |

Test Specification:

FCC 47 CFR Part 15, Subpart B – Verification (USA)
ICES-003 Issue 4 February 2004 (Canada)

Test Location: 303 River Road, R.R. 19, Ottawa, Ontario, Canada, K1V 1H2

Limits of Responsibility:

The results included in this test report apply only to the equipment listed within this report as being the Equipment Under Test (EUT). Equipment listed as support equipment is not considered to be part of the EUT. In some instances, the EUT may consist of multiple devices, and will be so indicated in the report.



Statement of Compliance

FCC 47 CFR Part 15, Subpart B for Digital Devices (Class B)	TEST RESULT
	PASS/FAIL/NA
Radiated Disturbance	PASS
Conducted Disturbance at Mains Port	PASS
<ul style="list-style-type: none">- Test Method Used: ANSI C63.4-2003- System Power: 120 VAC / 60 Hz- The equipment was tested for conducted emissions from 0.15 MHz to 30 MHz using a 50 μH line impedance stabilization network (L.I.S.N.) as described in ANSI C63.4-2003. Peripheral equipment was also operated through a 50 μH L.I.S.N.	
ICES-003 Issue 4 February 2004 (Class B)	TEST RESULT
	PASS/FAIL/NA
Radiated Disturbance	PASS
Conducted Disturbance at Mains Port	PASS
<ul style="list-style-type: none">- Test Method Used: CISPR 22- System Power: 120 VAC / 60 Hz- All tests were performed using measurement apparatus defined in CISPR 16-1.	

Measurement Uncertainty

Measurement	Test Specification	U _{lab}
Conducted disturbance	9–150 kHz	4.0 dB
	0.15–30 MHz	3.6 dB
Radiated disturbance	30–200 MHz <i>Horizontal polarization</i>	4.7 dB
	200–1000 MHz <i>Horizontal polarization</i>	4.7 dB
	30–200 MHz <i>Vertical polarization</i>	4.9 dB
	200–1000 MHz <i>Vertical polarization</i>	4.9 dB

Accuracy of Measurement

Measurement uncertainty was calculated using the methods described in CISPR 16-4 Specification for radio disturbance and immunity measuring apparatus and methods – Part 4: Uncertainty in EMC measurements and Nemko Canada Inc. procedure EMC/MUC/001 Uncertainty in EMC Measurements.

Lab Environmental Conditions

Ambient Temperature: 15 °C to 35 °C,
Relative Humidity: 30 % to 60 %,
Atmospheric Pressure: 86 kPa (860 mbar) to 106 kPa (1 060 mbar)

Engineering Considerations

Product Modification Required for Compliance

None

Justification

None

Deviations from Standard Test Procedure

None

Test Report Revision History

Revision #	Details of changes made to test report
-	Original Report Issued
1	Setup photos removed.



General Information Regarding the Equipment Under Test (EUT)

Date Received In Laboratory:

May 4, 2009

Nemko Identification Number:

Item # 2 and 5

Description & Theory of Operation:

DECT 6.0 System for use with Panasonic PBX via IP connection, base station, 1.9 GHz band operation

EUT Clock and Operational Frequencies:

10.368 MHz for Baseband IC, 16.384 MHz for FPGA, 1,920–1.930 GHz (RF carrier frequency)

Exercise/Monitoring method:

A call is established from the handset through the DECT 6 connected to PBX.

Software Version:

Ver. 3.002

Equipment Configuration

Setup Configurations

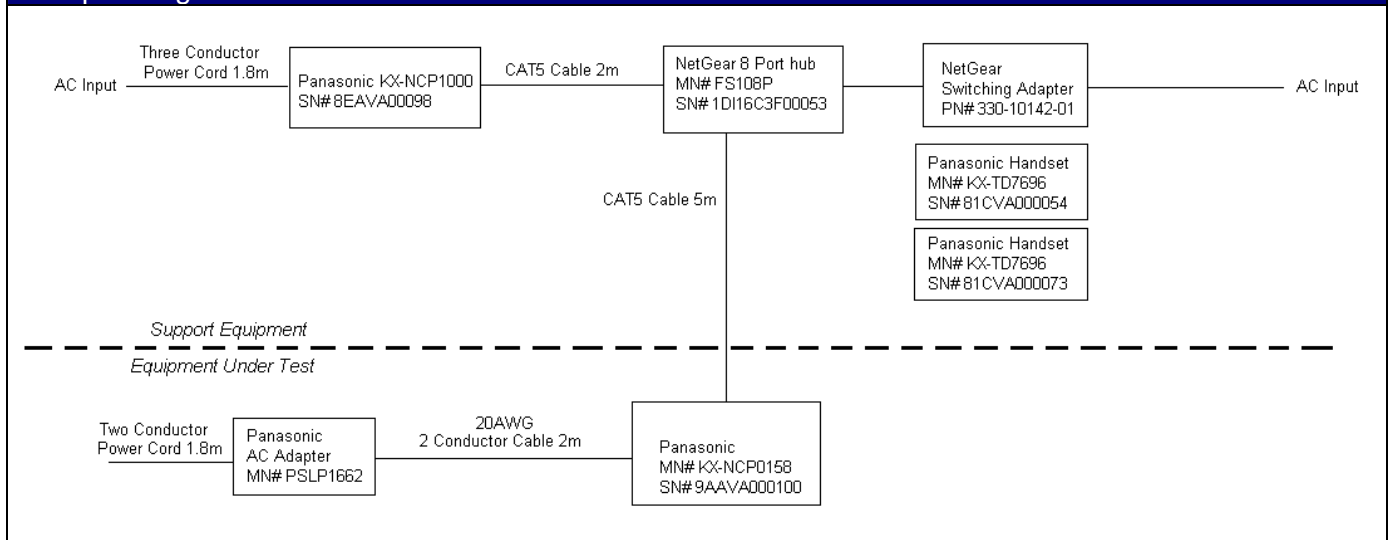



Radiated Disturbance

Test Date: May 6, 2009		
Engineer's Name: David Duchesne		
Configuration: Floor Standing		
Enclosure Investigation Data		
Result: Refer to spectral plots of this section.		
Facility: 3 m Semi Anechoic Chamber Measuring Distance: 3 m Antenna Height: 1–4 m		
<table style="width: 100%; border: none;"> <tr> <td style="width: 50%; vertical-align: top; padding: 2px;"> <p>Preview measurements:</p> <p>30 MHz to 1 GHz</p> <p>Receiver settings:</p> <ul style="list-style-type: none"> – Peak Detector, Max Hold – 120 kHz RBW <p>1 GHz to 40 GHz</p> <p>Spectrum analyzer settings:</p> <ul style="list-style-type: none"> – Peak Detector, Max Hold – 1 MHz RBW/3MHz VBW </td> <td style="width: 50%; vertical-align: top; padding: 2px;"> <p>Final measurement:</p> <p>30 MHz to 1 GHz</p> <p>Receiver settings:</p> <ul style="list-style-type: none"> – Q-Peak Detector – 120 kHz RBW <p>1 GHz to 40 GHz</p> <p>Receiver settings:</p> <ul style="list-style-type: none"> – Average Detector – 1 MHz RBW </td> </tr> </table> <ul style="list-style-type: none"> – The spectral plot is a combined vertical and horizontal scan. – Spectral plots have been corrected with transducer factors for antennas, cable loss, amplifiers, and attenuators. – Limits have been adjusted to reflect 3 m measurements. – The preview measurement was generated with receiver in continuous scan mode while the EUT was rotated and antenna adjusted for maximized radiated emission. – All emissions detected were more than 6 dB from limit. 	<p>Preview measurements:</p> <p>30 MHz to 1 GHz</p> <p>Receiver settings:</p> <ul style="list-style-type: none"> – Peak Detector, Max Hold – 120 kHz RBW <p>1 GHz to 40 GHz</p> <p>Spectrum analyzer settings:</p> <ul style="list-style-type: none"> – Peak Detector, Max Hold – 1 MHz RBW/3MHz VBW 	<p>Final measurement:</p> <p>30 MHz to 1 GHz</p> <p>Receiver settings:</p> <ul style="list-style-type: none"> – Q-Peak Detector – 120 kHz RBW <p>1 GHz to 40 GHz</p> <p>Receiver settings:</p> <ul style="list-style-type: none"> – Average Detector – 1 MHz RBW
<p>Preview measurements:</p> <p>30 MHz to 1 GHz</p> <p>Receiver settings:</p> <ul style="list-style-type: none"> – Peak Detector, Max Hold – 120 kHz RBW <p>1 GHz to 40 GHz</p> <p>Spectrum analyzer settings:</p> <ul style="list-style-type: none"> – Peak Detector, Max Hold – 1 MHz RBW/3MHz VBW 	<p>Final measurement:</p> <p>30 MHz to 1 GHz</p> <p>Receiver settings:</p> <ul style="list-style-type: none"> – Q-Peak Detector – 120 kHz RBW <p>1 GHz to 40 GHz</p> <p>Receiver settings:</p> <ul style="list-style-type: none"> – Average Detector – 1 MHz RBW 	
Notes		
None		
Deviations		
None		
Test Result		
Final Test Result: Pass		



Nemko Canada Inc.,
303 River Road, R.R. 5, Ottawa, Ontario, Canada, K1V 1H2

Report No: 127679-1R1TRFEMC

Radiated Disturbance, continued

Test Equipment Used

Equipment	Manufacturer	Model No.	Asset/Serial No.	Next Cal.
3 m EMI Test Chamber	TDK	SAC-3	FA002047	May 06/09
Bilog	Sunol	JB3	FA002108	Jan. 27/10
Receiver/Spectrum Analyzer	Rohde & Schwarz	ESU 26	FA002043	Dec. 16/09
Horn Antenna #2	EMCO	3115	FA000825	Jan. 21/10
50 Coax cable	HUBER + SUHNER	None	FA002022	July 07/09
50 Coax cable	HUBER + SUHNER	None	FA002074	July 07/09

Note: N/A = Not Applicable, NCR = No Cal Required, COU = CAL On Use

Radiated Disturbance, continued

Spectral Plots

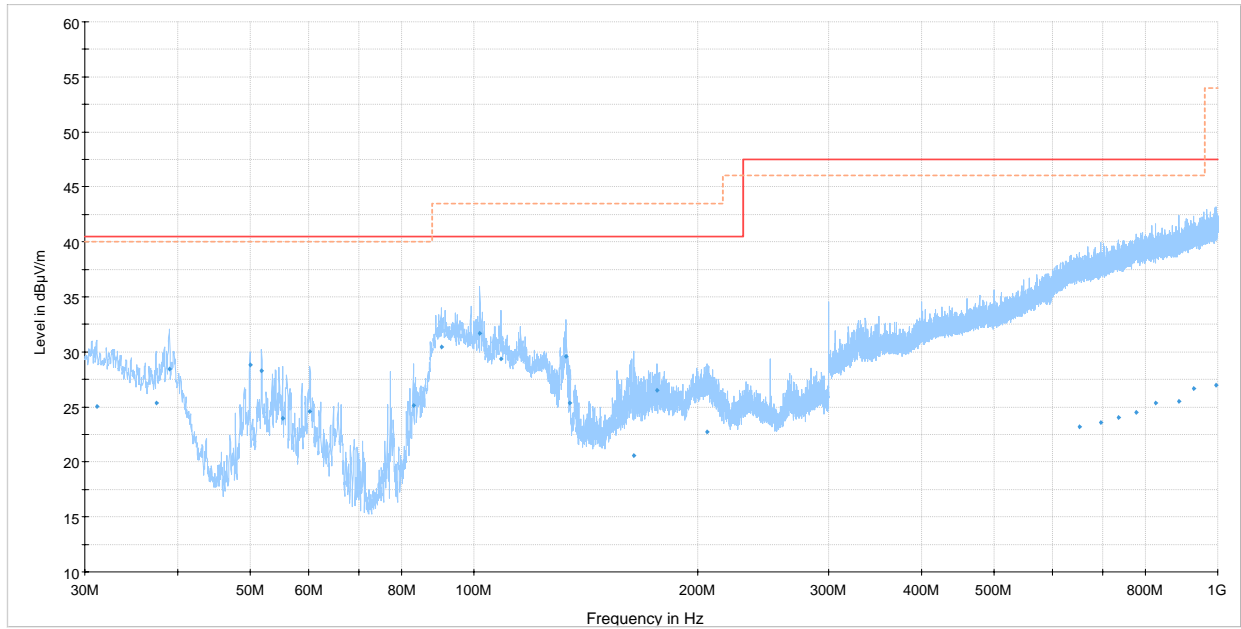

Vertical and Horizontal
 — CISPR22 Class B QP 3m Limit - - - FCC Part 15 Class B 3m QP Limit — Preview Peak Detector • Final Q-Peak Detector

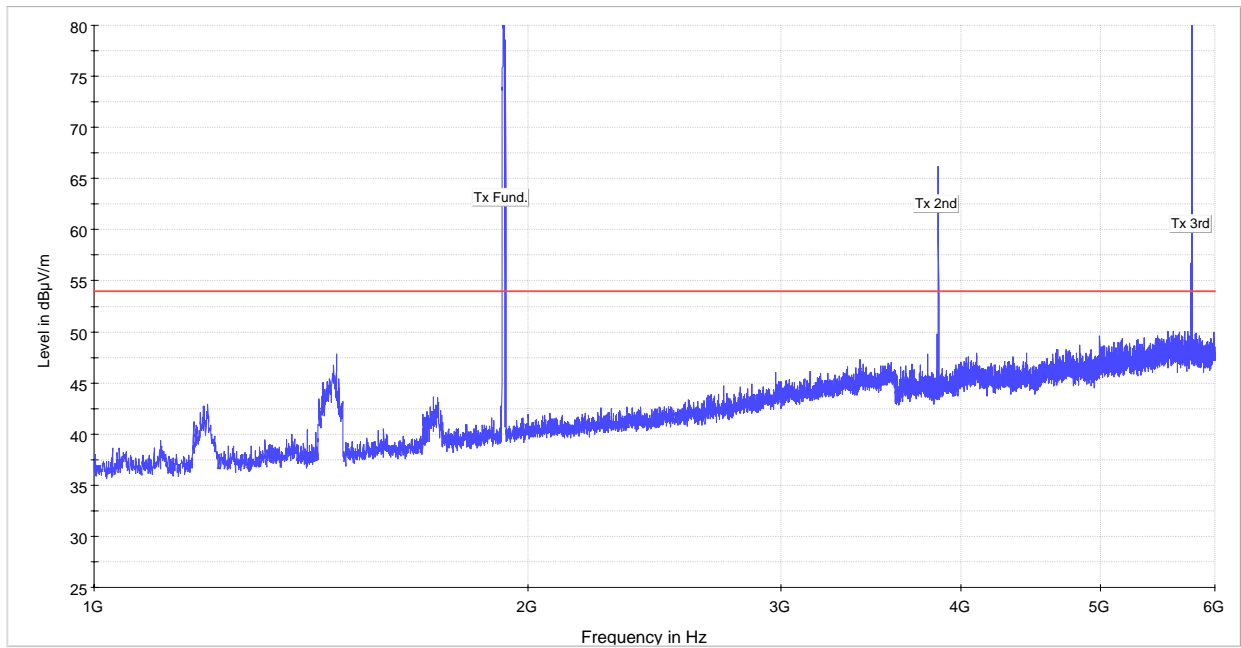

— MaxPeak-MaxHold — FCC Part 15 Class B 3m AV



Nemko Canada Inc.,
303 River Road, R.R. 5, Ottawa, Ontario, Canada, K1V 1H2

Report No: 127679-1R1TRFEMC

Conducted Disturbance at Mains Port

Test Date: May 6, 2009

Engineer's Name: David Duchesne

Configuration: Floor Standing

Port Investigation Data

Port under test: AC Input

Result: Refer to spectral plots of this section.

Preview measurements:

0.15 MHz to 30 MHz

Receiver settings:

- Peak Detector, Max Hold and Average
- 9 kHz RBW

Final measurement:

0.15 MHz to 30 MHz

Receiver settings:

- Q-Peak Detector and Average
- 9 kHz RBW

- Spectral plots have been corrected for transducer factors; cable loss, LISN, and attenuator.
- Emissions detected within 6 dB of limit were re-measured with a quasi peak or average detector for a final measurement.

Notes

None

Deviations

None

Test Result

Final Test Result: Pass

Test Equipment Used

Equipment	Manufacturer	Model No.	Asset/Serial No.	Next Cal.
International Power Supply	California Inst.	3001i	FA001021	Jan. 13/10
Receiver/Spectrum Analyzer	Rohde & Schwarz	ESU 26	FA002043	Dec. 16/09
50 Coax cable	HUBER + SUHNER	None	FA002015	Aug. 05/09
LISN	Rohde & Schwarz	ENV216	FA002023	Sept. 02/09

Note: N/A = Not Applicable, NCR = No Cal Required, COU = CAL On Use

Conducted Disturbance at Mains, continued

Spectral Plots

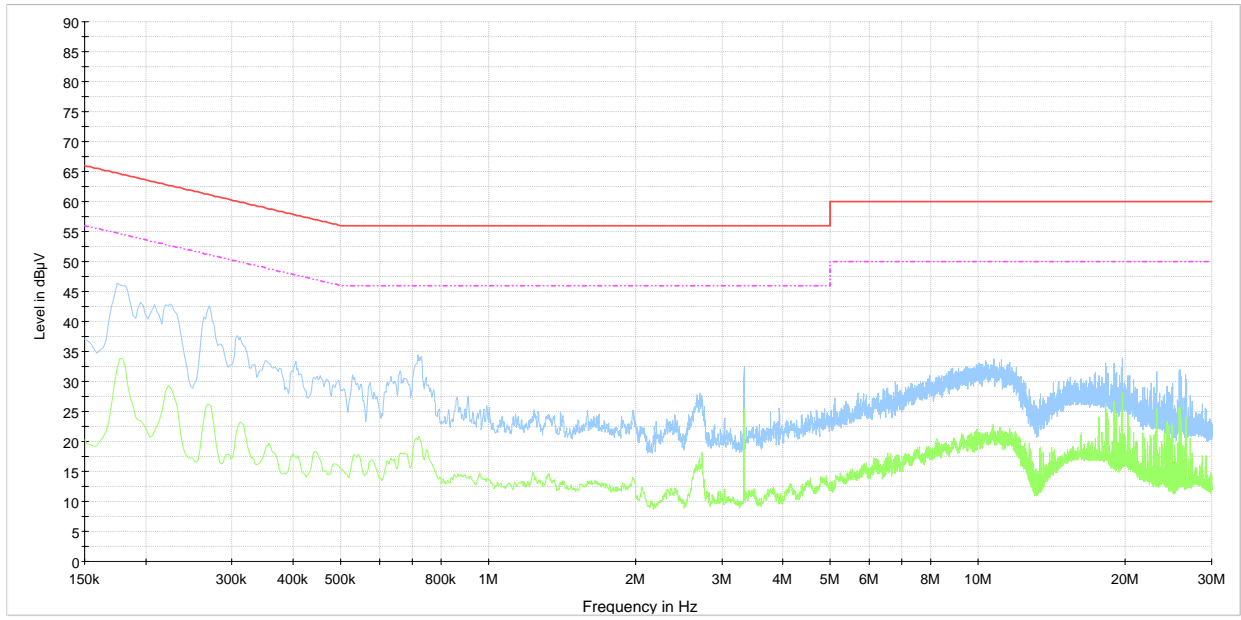

120VAC/60Hz, Phase
— CISPR 22 Mains QP Class B Limit - - - CISPR 22 Mains AV Class B Limit — Preview Peak Detector — Preview Average Detector

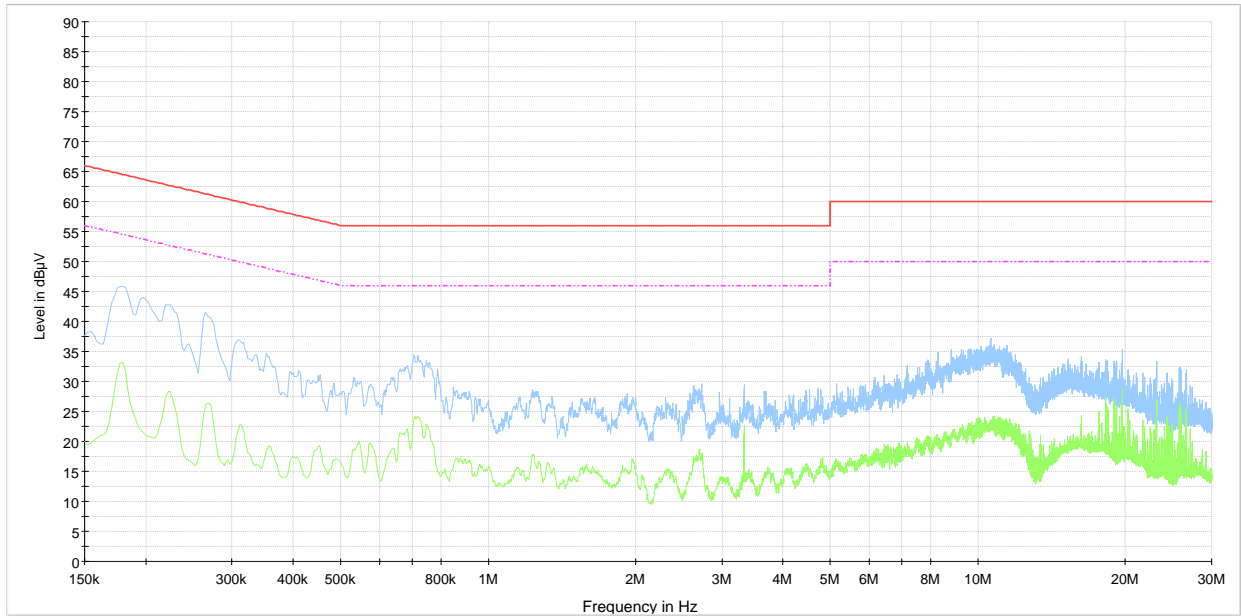

120VAC, Neutral
— CISPR 22 Mains QP Class B Limit - - - CISPR 22 Mains AV Class B Limit — Preview Peak Detector — Preview Average Detector