

Prüfbericht - Nr.: 50027424 001 <i>Test Report No.:</i>		Seite 1 von 123 <i>Page 1 of 123</i>	
Auftraggeber: <i>Client:</i>		Panasonic System Networks Co., Ltd. 4-1-62 Minoshima, Hakata-ku, Fukuoka-shi, Fukuoka 812-8531, Japan	
Gegenstand der Prüfung: <i>Test Item:</i>		Hybrid IP-PBX	
Bezeichnung: <i>Identification:</i>	KX-HTS824	Serien-Nr.: <i>Serial No.:</i>	E.S.(No.2), E.S.(No.3)
Wareneingangs-Nr.: <i>Receipt No.:</i>	A000200568-001 A000200568-002	Eingangsdatum: <i>Date of Receipt:</i>	2015-05-18
Zustand des Prüfgegenstandes bei Anlieferung: Good <i>Condition of Test Item at Delivery:</i>			
Prüfport: TÜV Rheinland Japan Ltd. – Global Technology Assessment Center <i>Testing Location:</i> 4-25-2 Kita-Yamata, Tsuzuki-ku, Yokohama 224-0021, Japan			
Prüfgrundlage: FCC 47 CFR Part 15, Subpart C, Section 15.247 (October 30, 2015). <i>Test Specification:</i> ANSI C63.10-2013 KDB Publication No. 558074 D01: Guidance for Performing Compliance Measurements on Digital Transmission Systems (DTS) Operating Under §15.247 (v03r03) KDB Publication No. 662911 D01: Emissions Testing of Transmitters with Multiple Outputs in the Same Band RSS-247 (Issue 1): 2015 RSS-Gen (Issue 4): 2014 ANSI C63.10-2013			
Prüfergebnis: Der Prüfgegenstand entspricht oben genannter Prüfgrundlage(n). <i>Test Result:</i> The test item passed the test specification(s).			
Prüflaboratorium: TÜV Rheinland Japan Ltd. – Global Technology Assessment Center <i>Testing Laboratory:</i> 4-25-2 Kita-Yamata, Tsuzuki-ku, Yokohama 224-0021, Japan			
geprüft/ tested by:		kontrolliert/ reviewed by:	
2016-01-20	K. Dezaki / Inspector	2016-01-22	R. Meiranke / Reviewer
Datum <i>Date</i>	Name/Stellung <i>Name/Position</i>	Unterschrift <i>Signature</i>	Datum <i>Date</i>
Sonstiges / Other Aspects:			
Abkürzungen: P(ass) = entspricht Prüfgrundlage F(ail) = entspricht nicht Prüfgrundlage N/A = nicht anwendbar N/T = nicht getestet		Abbreviations: P(ass) = passed F(ail) = failed N/A = not applicable N/T = not tested	
Dieser Prüfbericht bezieht sich nur auf das o.g. Prüfmuster und darf ohne Genehmigung der Prüfstelle nicht auszugsweise vervielfältigt werden. Dieser Bericht berechtigt nicht zur Verwendung eines Prüfzeichens. <i>This test report relates to the a. m. test sample. Without permission of the test center this test report is not permitted to be duplicated in extracts. This test report does not entitle to carry any safety mark on this or similar products.</i>			

Prüfbericht - Nr.: 50027424 001
Test Report No.:Seite 2 von 123
Page 2 of 123

TEST SUMMARY

5.1.1 SUPPLY VOLTAGE REQUIREMENTS

RESULT: PASS

5.1.2 ANTENNA REQUIREMENTS

RESULT: PASS

5.1.3 RESTRICTED BANDS OF OPERATION

RESULT: PASS

5.2.1 CONDUCTED OUTPUT POWER

RESULT: PASS

5.2.2 6dB BANDWIDTH

RESULT: PASS

5.2.3 99% BANDWIDTH**5.2.4 CONDUCTED SPURIOUS EMISSIONS**

RESULT: PASS

5.2.5 PEAK POWER SPECTRAL DENSITY

RESULT: PASS

5.3.1 RADIATED SPURIOUS EMISSIONS OF TRANSMITTER

RESULT: PASS

5.4.1 AC POWER LINE CONDUCTED EMISSION OF TRANSMITTER

RESULT: PASS

Contents

1.	GENERAL REMARKS	5
1.1	COMPLEMENTARY MATERIALS	5
2.	TEST SITES	5
2.1	TEST FACILITIES	5
2.2	LIST OF TEST AND MEASUREMENT INSTRUMENTS	6
2.3	MEASUREMENT UNCERTAINTY	7
3.	GENERAL PRODUCT INFORMATION	8
3.2	SYSTEM DETAILS	8
3.3	CLOCK FREQUENCIES	9
3.4	NOISE SUPPRESSING PARTS.....	9
4.	TEST SET-UP AND OPERATION MODES	10
4.1	TEST METHODOLOGY	10
4.2	OPERATION MODES	10
4.3	PHYSICAL CONFIGURATION FOR TESTING	10
4.4	TEST SOFTWARE	12
4.5	SPECIAL ACCESSORIES AND AUXILIARY EQUIPMENT	13
4.6	COUNTERMEASURES TO ACHIEVE COMPLIANCE.....	13
5.	TEST RESULTS RADIO	14
5.1	TECHNICAL REQUIREMENTS.....	14
5.1.1	<i>Supply Voltage Requirements</i>	<i>14</i>
5.1.2	<i>Antenna Requirements</i>	<i>14</i>
5.1.3	<i>Restricted Bands of Operation.....</i>	<i>15</i>
5.2	CONDUCTED MEASUREMENTS AT ANTENNA PORT.....	16
5.2.1	<i>Conducted Output Power.....</i>	<i>16</i>
5.2.2	<i>6dB Bandwidth.....</i>	<i>19</i>
5.2.3	<i>99% Bandwidth</i>	<i>32</i>
5.2.4	<i>Conducted Spurious Emissions.....</i>	<i>45</i>
5.2.5	<i>Peak Power Spectral Density</i>	<i>82</i>
5.3	RADIATED MEASUREMENTS	95
5.3.1	<i>Radiated Spurious Emissions of Transmitter.....</i>	<i>95</i>
5.4	AC POWER LINE CONDUCTED MEASUREMENTS	110
5.4.1	<i>AC Power Line Conducted Emission of Transmitter.....</i>	<i>110</i>
6.	PHOTOGRAPHS OF THE TEST SETUP	115
7.	LIST OF TABLES.....	120

Produkte
Products

Prüfbericht - Nr.: 50027424 001
Test Report No.:

Seite 4 von 123
Page 4 of 123

8.	LIST OF FIGURES	122
9.	LIST OF PHOTOGRAPHS.....	123

1. General Remarks

1.1 Complementary Materials

There is no attachment to this test report.

2. Test Sites

2.1 Test Facilities

TÜV Rheinland Japan Ltd. – Global Technology Assessment Center
4-25-2 Kita-Yamata, Tsuzuki-ku, Yokohama 224-0021, Japan

The used test equipment is in accordance with CISPR 16 for measurement of radio interference.

The Federal Communications Commission has reviewed the technical characteristics of the radiated and conducted emission facilities and has found these test sites to be in compliance with the requirements of section 2.948 of the FCC rules. The description of the test facility is listed under FCC registration number 299054.

The Industry Canada has reviewed the technical characteristics of the radiated and conducted emission facilities and has found these test sites to be in compliance with Canadian requirements. The description of the test facility is listed under OATS filing number 3466B-1.

The test facility is accredited by VLAC (member of ILAC) under number VLAC-017 according to ISO/IEC 17025:2005.



TÜV Rheinland Japan Ltd. is accredited by the Federal Communications Commission as a Conformity Assessment Body under Designation Number JP0017 and Test Firm Registration Number 386498.

Prüfbericht - Nr.: 50027424 001
Seite 6 von 123

Test Report No.:

Page 6 of 123

2.2 List of Test and Measurement Instruments

Table 1: List of Test and Measurement Equipment

Kind of Equipment	Manufacturer	Model Name	Serial Number	Equipment ID	Calibrated until
For Antenna Port Conducted Emission					
Receiver	Rohde & Schwarz	ESU 40	100029	RF-0021	2016-03
RF Power Meter	Agilent	N1911A	MY451017 37	RF-0393	2016-01
RF Peak Power Sensor	Agilent	N1921A	MY452422 28	RF-0394	2015-12
For AC Power Line Conducted Emission					
Conducted Emission Measurement Software	Toyo Corporation	EP5/CE	Ver. 5.0.20	RF-0025	2016-01
Receiver	Rohde & Schwarz	ESU 8	100025	RF-0020	2016-08
LISN	Rohde & Schwarz	ENV216	100276	RF-0016	2016-05
LISN	Rohde & Schwarz	ENV216	101958	RF-0708	2016-09
For Radiated Emission					
Radiated Emission Measurement Software (below 30MHz)	Toyo Corporation	EP5/ME	Ver. 5.0.10	RF-0172	2016-01
Radiated Emission Measurement Software (above 30MHz)	Toyo Corporation	EP7/RE	Ver. 5.0.2	RF-0026	2016-01
Receiver	Rohde & Schwarz	ESU 40	100029	RF-0021	2016-03
RF Selector (10m Chamber)	Toyo Corporation	NS4900	0703-182	RF-0029	2016-01
Loop Antenna with Amplifier, 9kHz-30MHz	Rohde & Schwarz	HFH2-Z2	100139	RF-0048	2016-05
Trilog Antenna No. 2, 30-1000MHz	Schwarzbeck	VULB9168	9168-475	RF-0462	2015-12
Biconical Antenna, 30-300MHz	EMCO	3110B	9603-2379	RF-0207	2016-08
Log-Periodic Antenna, 300-1000MHz	Schwarzbeck	UHALP 9108 A1	UHALP 9108-A 0845	RF-0287	2016-08
3dB Attenuator	Tamagawa Electronics	CFA-01	-	RF-0265	2016-01
Low Noise Preamplifier, 9kHz-1GHz	TSJ	MLA-10K01-B01-35	1370750	RF-0253	2016-01
Low Pass Filter, DC-1GHz	R&K	LP1000CH3	12104001	RF-0515	2016-01
Horn Antenna, 1-8GHz	Schwarzbeck	BBHA9120D	1059	RF-0553	2016-06
Microwave Preamplifier, 1-8GHz	Toyo Corporation	TPA0108-40	0634	RF-0052	2016-01
Band Reject Filter, 1-8GHz	Nitsuki	NF-49BT	027	RF-0131	2016-01

Prüfbericht - Nr.: 50027424 001
Seite 7 von 123

Test Report No.:

Page 7 of 123

Kind of Equipment	Manufacturer	Model Name	Serial Number	Equipment ID	Calibrated until
Horn Antenna with Preamplifier, 8-18GHz	Toyo Corporation	HAP06-18W	00000025	RF-0065	2016-07
Horn Antenna with Preamplifier, 18-26.5GHz	Toyo Corporation	HAP18-26N	00000010	RF-0070	2016-07
Constant Voltage Constant Frequency Stabilizers and Power Accessories					
CVCF (3m Chamber)	NF Corporation	ES2000S	9075613	RF-0208	N/A
CVCF Booster (3m chamber)	NF Corporation	ES2000B	9072132	RF-0209	N/A
CVCF (Shielded Room)	NF Corporation	ES2000S	9075612	RF-0210	N/A
CVCF Booster (Shielded Room)	NF Corporation	ES2000B	9074403	RF-0211	N/A
CVCF (10m Chamber)	NF Corporation	ES2000U	9067307	RF-0212	N/A
CVCF Booster (10m Chamber)	NF Corporation	ES2000B	9074408	RF-0213	N/A
True RMS Multimeter	Fluke	87V	97680445	RF-0281	2016-01
True RMS Multimeter	Fluke	87V	97680450	RF-0282	2016-02

Conformance of the used measurement and test equipment with the requirements of ISO/IEC 17025:2005 has been confirmed before testing.

2.3 Measurement Uncertainty

Table 2: Emission Measurement Uncertainty

Measurement Type	Frequency	Uncertainty
AC Power Line Conducted Emission	150kHz - 30MHz	±2.0dB
Antenna Port Conducted Emission	20Hz - 40GHz	±1.5dB
Radiated Emission	150kHz - 30MHz	±4.7dB
	30MHz - 1GHz	±4.7dB
	> 1GHz	±4.7dB

3. General Product Information

3.1 Product Function and Intended Use

The EUT (Equipment Under Test) KX-HTS824 is a Hybrid IP-PBX used at locations other than telecommunication centers e.g. within offices, customers' premises, etc. The EUT has Wi-Fi router function.

3.2 System Details

Frequency range:	2412 – 2462MHz
Number of channels:	11
Channel spacing:	5MHz
Modulation type:	DSSS coupled with DBPSK, DQPSK and CCK OFDM coupled with BPSK, QPSK, 16QAM and 64QAM
FCC classification:	DTS
IC classification:	Spread Spectrum/Digital Device (2400-2483.5 MHz)
Emission designator:	G1D
Radio standard:	IEEE 802.11b IEEE 802.11g IEEE 802.11n (20HT/40HT)
Frequency range:	2412 – 2472MHz
Output power (measured):	802.11b (DSSS) 37.15 mW 802.11g (OFDM) 67.92 mW 802.11n (OFDM) 123.59 mW
Antenna gain:	2.14dBi for each antenna 5.15dBi (= 2.14dBi + 10*log(2)) for 2 antenna system, to take into account correlation effects
Antenna type:	Antenna 0: Pattern antenna (printed on PCB) Antenna 1: Pattern antenna (printed on PCB)
Antenna mounting type:	Internal of EUT
Modulation type:	IEEE 802.11b (DSSS): BPSK, QPSK, CCK IEEE 802.11g (OFDM): BPSK, QPSK, 16 QAM, 64QAM IEEE 802.11n (OFDM): BPSK, QPSK, 16 QAM, 64QAM
Signal spreading:	DSSS and OFDM (coupled with modulation type above)
Transmit speed:	802.11b: 11 / 5.5 / 2 / 1 Mbps 802.11g: 54 / 48 / 36 / 24 / 18 / 12 / 9 / 6 Mbps 802.11n (20HT): 65 / 58.5 / 52 / 39 / 26 / 19.5 / 13 / 6.5 Mbps 802.11n (40HT): 135 / 121.5 / 108 / 81 / 54 / 40.5 / 27 / 13.5 Mbps
Number of channels:	11

Prüfbericht - Nr.: 50027424 001**Seite 9 von 123***Test Report No.:**Page 9 of 123*

Channel spacing: 5MHz
Rated temperature: 0 – 40°C
Rated voltage: AC 120V
Rated frequency: 50/60Hz
Rated current: 1.3 - 0.9A
Protection class: I for AC
Duty cycle for radio testing: 100%

Note:

Protocols IEEE 802.11b and g transmit either from antenna 0 or antenna 1, but not from both antennas at the same time. Protocol IEEE 802.11n (20HT/40HT) can transmit from both antennas simultaneously.

3.3 Clock Frequencies

The highest frequency generated or used by the EUT is 720MHz for the digital interface.

3.4 Noise Suppressing Parts

Refer to schematics.

4. Test Set-up and Operation Modes

4.1 Test Methodology

The test methodology used is based on the requirements of 47 CFR Part 15, Sections 15.31, 15.33, 15.35, 15.205, 15.207, 15.209, KDB Publication No. 558074 D01 and KDB Publication No. 662911 D01.

The test methods, which have been used, are based on ANSI C63.10 and RSS-Gen (Issue 4).

For details, see under each test item.

4.2 Operation Modes

The basic operation modes used for testing are:

- A. EUT transmits a modulated signal at lowest channel
- B. EUT transmits a modulated signal at middle channel
- C. EUT transmits a modulated signal at highest channel

Channel frequencies and communication modes used for testing:

Protocol	Lowest channel	Middle channel	Highest channel
IEEE 802.11b	2412MHz	2437MHz	2462MHz
IEEE 802.11g	2412MHz	2437MHz	2462MHz
IEEE 802.11n (20HT)	2412MHz	2437MHz	2462MHz
IEEE 802.11n (40HT)	2422MHz	2447MHz	2452MHz

Note:

Unless otherwise specified, the measurements were made with the transmit speed (data rate) corresponding to the worst case output power (found by peak output power measurement.)

4.3 Physical Configuration for Testing

The test system was configured in a typical fashion (as a customer would normally use it).

The justification and manipulation of cables and equipment in order to simulate a worst-case behavior of the test setup has been carried out as prescribed in ANSI C63.10-2013.

Figure 1: Block Diagram

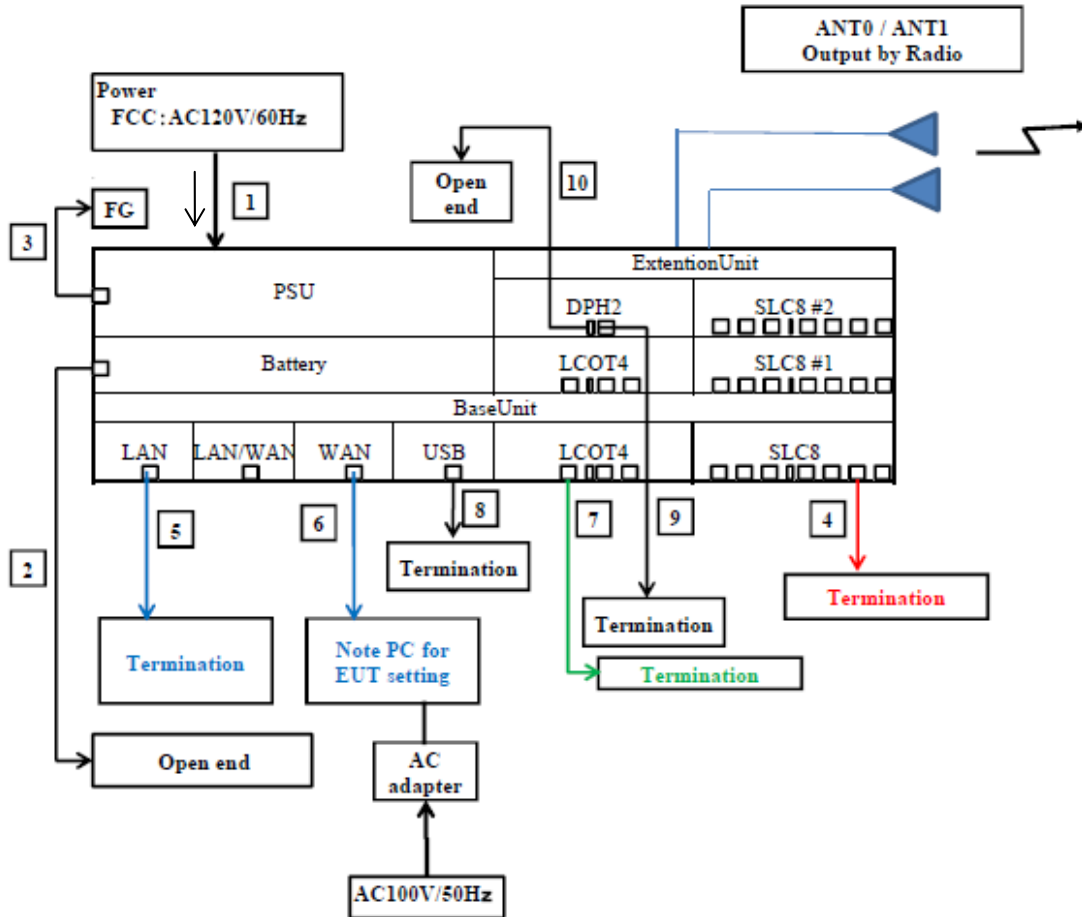

Table 3: Interfaces present on the EUT

No.	Interface(s):	Cable Length, Shielding	Cable Classification	Remarks
1.	AC Main input (PSU)	2m, Un-shielded	AC Input Power Port	
2.	Battery port	1m, Un-shielded	DC Input Power Port of Battery	Open
3.	FG (Frame Ground)	2m, Un-shielded	Frame ground for PE	
4.	Extension line interface for telephone (Main Unit and SLC8)	1m, Un-shielded	Telecom Line	Terminated by resistor *100 Ohms
5.	LAN (Ethernet)	3m, Un-shielded	Telecom Line	Terminated by Ethernet hub
6.	LAN/WAN (Ethernet)	3m, Un-shielded	Telecom Line	Connected to laptop computer
7.	LINE 1 – 4 Analogue PSTN line interface (Main Unit and LCOT4)	1m Un-shielded	Telecom Line	Terminated by resistor
8.	USB	1m, Un-shielded	Signal Line and DC power Port	Terminated by USB hub

Prüfbericht - Nr.: 50027424 001
Seite 12 von 123
Test Report No.:
Page 12 of 123

9.	Door phone (DPH2)	1m, Un-shielded	Telecom Line	Terminated by dummy load
10.	Door opener (DPH2)	1m, Un-shielded	Signal Line	Terminated by dummy load

Notes:

Two test samples were available. Sample E.S.(No.2) was used for antenna conducted measurements and sample E.S.(No.3) was used for radiated measurements.

For antenna conducted measurements, the antennas were replaced by a 50Ω antenna connector.

For more details, refer to section: Photographs of the Test Set-Up.

4.4 Test Software

The EUT was provided by the manufacturer with suitable software to allow operation in all the required modes.

Driver and Firmware version on EUT for testing:

WLAN driver version: 03.05.00.00.39_r2.0 by Panasonic System Networks Co., Ltd.

WLAN MAC FW version: FW_3.5.0_r4552 by Panasonic System Networks Co., Ltd.

Following two software programs were running on the laptop computer connected to the EUT. They were used to enable the test operation modes listed in section 4.2 as appropriate.

Lantiq DUT 6.49

Teraterm 4.88

4.5 Special Accessories and Auxiliary Equipment

The product has been tested together with the following additional accessories:

1. Product: Laptop Computer
Model: CF-SX2ADHCS
Manufacturer: Panasonic
Rated Voltage: DC 16V
Protection Class: III
Serial No.: 3HKSA33632

2. Product: AC Adapter for Laptop Computer
Model: CF-AA6412CJS
Manufacturer: Panasonic
Rated Voltage: AC 100V-240V
Input Current: 1.5A
Frequency: 50-60Hz
Protection Class: II

3. Product: Ethernet Hub (for termination use)
Model: FXG-08IMB2
Manufacturer: PCi
Rated Voltage: AC 100-240V
Input Current: 0.3A
Protection Class: II
Serial No.: 07KD00762AR

4. Product: USB Hub (for termination use)
Model: U2H-TV003
Manufacturer: Elecom
Rated Voltage: DC 5V
Input Current: < 1A
Protection Class: III

4.6 Countermeasures to achieve Compliance

No additional measures were employed to achieve compliance.

5. Test Results RADIO

5.1 Technical Requirements

5.1.1 Supply Voltage Requirements

RESULT: **PASS**

Requirements:

FCC 15.31(e)

For intentional radiators, measurements of the variation of the input power or the radiated signal level of the fundamental frequency component of the emission, as appropriate, shall be performed with the supply voltage varied between 85% and 115% of the nominal rated supply voltage. For battery operated equipment, the equipment tests shall be performed using a new battery.

Verdict:

The EUT has an internal voltage regulator to supply the RF circuit. Hence it complies with the supply voltage requirements.

5.1.2 Antenna Requirements

RESULT: **PASS**

Requirements:

FCC 15.203

An intentional radiator shall be designed to ensure that no antenna other than that furnished by the responsible party shall be used with the device.

Verdict:

The EUT has internal antennas which are not user accessible. Hence it complies with the antenna requirements.

Prüfbericht - Nr.: 50027424 001
*Test Report No.:***Seite 15 von 123**
Page 15 of 123

5.1.3 Restricted Bands of Operation

RESULT:**PASS**

Requirements:

FCC 15.205 and RSS-Gen 8.10

Only spurious emissions are permitted in any of the restricted frequency bands, unless otherwise specified.

Verdict:

The EUT operation frequency range is 2412-2462MHz. Therefore only spurious emissions may be found in the restricted bands of operation and the EUT complies with the restricted frequency band requirement.

Prüfbericht - Nr.: 50027424 001**Seite 16 von 123**

Test Report No.:

Page 16 of 123

5.2 Conducted Measurements at Antenna Port

5.2.1 Conducted Output Power

RESULT:**PASS**

Date of testing: 2015-11-02

Ambient temperature: 24°C

Relative humidity: 46%

Atmospheric pressure: 1012hPa

Requirements:

FCC 15.247(b)(3) and RSS-247 5.4(4)

For systems using digital modulation in the 2400-2483.5MHz band, the maximum peak output power is 1W (30dBm).

If transmitting antennas of directional gain greater than 6dBi are used, the conducted output power from the intentional radiator shall be reduced by the amount in dB that the directional gain of the antenna exceeds 6dBi.

Test procedure:

ANSI C63.10-2013, RSS-Gen 6.12, KDB Publication No. 558074 D01 and KDB Publication No. 662911 D01

The maximum peak output power was measured at the antenna port with a power sensor.

Prechecks were performed at all available data rates. The reported results correspond to the worst case data rates.

The readings of the measurements take into account the loss generated by all the involved cables.

The total antenna gain, taking into account correlation effects, is 5.18dBi. The maximum peak output power limit is therefore 30dBm.

The readings of the measurements given here below take into account the loss generated by all the involved cables.

Prüfbericht - Nr.: 50027424 001

Seite 17 von 123

Test Report No.:

Page 17 of 123

Table 4: Conducted Output Power, 11b_Antenna 0

Frequency [MHz]	Data Rate [Mbps]	Power Antenna 0 [dBm]	Limit [dBm]	Margin [dB]
2412	11	15.66	30.00	14.34
2437	11	15.39	30.00	14.61
2462	11	15.70	30.00	14.30

Table 5: Conducted Output Power, 11b_Antenna 1

Frequency [MHz]	Data Rate [Mbps]	Power Antenna 1 [dBm]	Limit [dBm]	Margin [dB]
2412	11	14.82	30.00	15.18
2437	11	14.74	30.00	15.26
2462	11	14.85	30.00	15.15

Table 6: Conducted Output Power, 11g_Antenna 0

Frequency [MHz]	Data Rate [Mbps]	Power Antenna 0 [dBm]	Limit [dBm]	Margin [dB]
2412	18	18.32	30.00	11.68
2437	18	18.16	30.00	11.84
2462	18	17.79	30.00	12.21

Table 7: Conducted Output Power, 11g_Antenna 1

Frequency [MHz]	Data Rate [Mbps]	Power Antenna 0 [dBm]	Limit [dBm]	Margin [dB]
2412	18	17.82	30.00	12.18
2437	18	18.10	30.00	11.90
2462	18	17.67	30.00	12.33

Table 8: Conducted Output Power, 11n(20HT)

Frequency [MHz]	Data Rate [Mbps]	Power Antenna 1 [dBm]	Power Antenna 2 [dBm]	Total Power [dBm]	Limit [dBm]	Margin [dB]
2412	26	18.11	17.69	20.92	30.00	9.08
2437	26	17.54	17.56	20.56	30.00	9.44
2462	26	17.98	16.76	20.42	30.00	9.58

Prüfbericht - Nr.: 50027424 001

Seite 18 von 123

Test Report No.:

Page 18 of 123

Table 9: Conducted Output Power, 11n(40HT)

Frequency (MHz)	Data Rate [Mbps]	Power Antenna 1 [dBm]	Power Antenna 2 [dBm]	Total Power [dBm]	Limit [dBm]	Margin [dB]
2422	54	15.66	14.82	18.27	30.00	11.73
2447	54	15.39	14.74	18.09	30.00	11.91
2452	54	15.70	14.85	18.31	30.00	11.69

Prüfbericht - Nr.: 50027424 001**Seite 19 von 123**

Test Report No.:

Page 19 of 123

5.2.2 6dB Bandwidth**RESULT:****PASS**

Date of testing: 2015-11-02

Ambient temperature: 24°C

Relative humidity: 46%

Atmospheric pressure: 1012hPa

Requirements:

FCC 15.247(a)(2) and RSS-247 5.2(1)

For systems using digital modulation in the 2400-2483.5MHz band, the 6dB bandwidth shall be at least 500kHz.

Test procedure:

ANSI C63.10-2013, RSS-Gen 6.6 and KDB Publication No. 558074 D01.

The 6dB bandwidth was measured at the antenna port with a spectrum analyzer using a peak detector. The resolution bandwidth was set to 100kHz and the video bandwidth to 300kHz. Markers placed at the lowest and highest intersections of the trace with a 6dBc line were used to calculate the emission bandwidth.

For protocols IEEE 802.11b and g, measurements were done on antenna 0, selected as representative antenna.

Table 10: 6dB Bandwidth, 11b_Antenna 0

Operating Frequency [MHz]	6dB Bandwidth [MHz]	Limit [MHz]
2412	7.69	0.5
2437	7.93	0.5
2462	7.69	0.5

Figure 2: 6dB Bandwidth, Mode A (2412MHz), 11b_Antenna 0

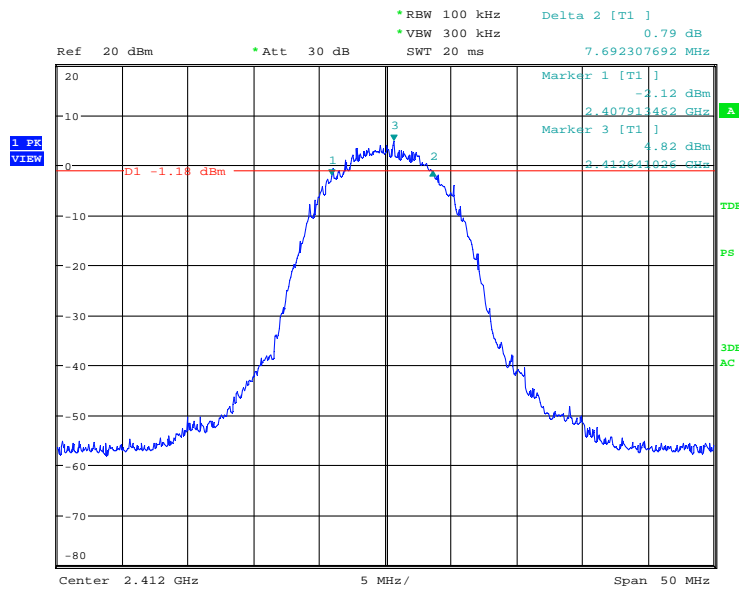

6dB bandwidth, mode 11b, 2412MHz
 Date: 2.NOV.2015 16:39:49

Figure 3: 6dB Bandwidth, Mode B (2437MHz), 11b_Antenna 0

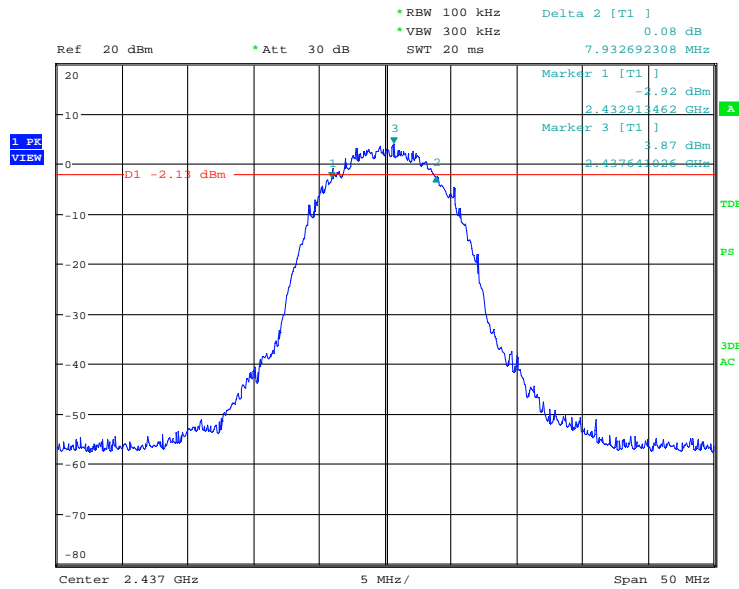

6dB bandwidth, mode 11b, 2437MHz
Date: 2.NOV.2015 16:50:58

Figure 4: 6dB Bandwidth, Mode C (2462MHz), 11b_Antenna 0

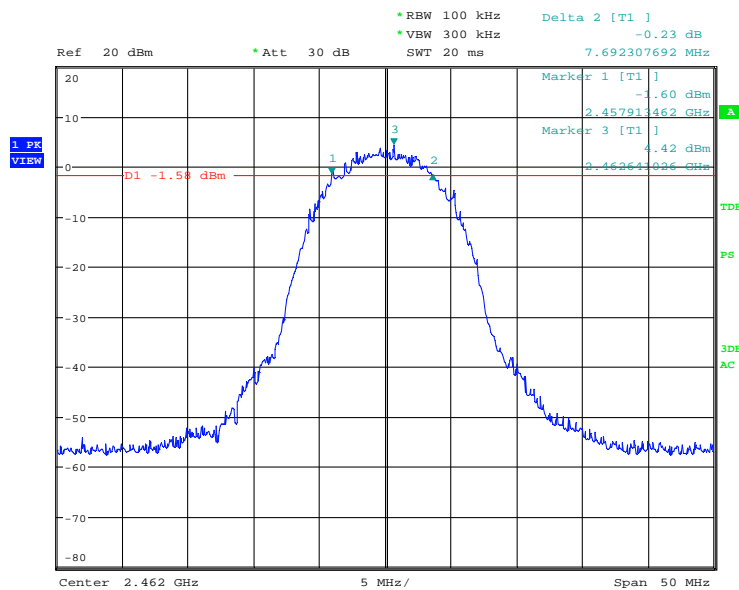

6dB bandwidth, mode 11b, 2462MHz
Date: 2.NOV.2015 17:02:18

Table 11: 6dB Bandwidth, 11g_Antenna 0

Operating Frequency [MHz]	6dB Bandwidth [MHz]	Limit [MHz]
2412	16.58	0.5
2437	16.66	0.5
2462	16.58	0.5

Figure 5: 6dB Bandwidth, Mode A (2412MHz), 11g_Antenna 0

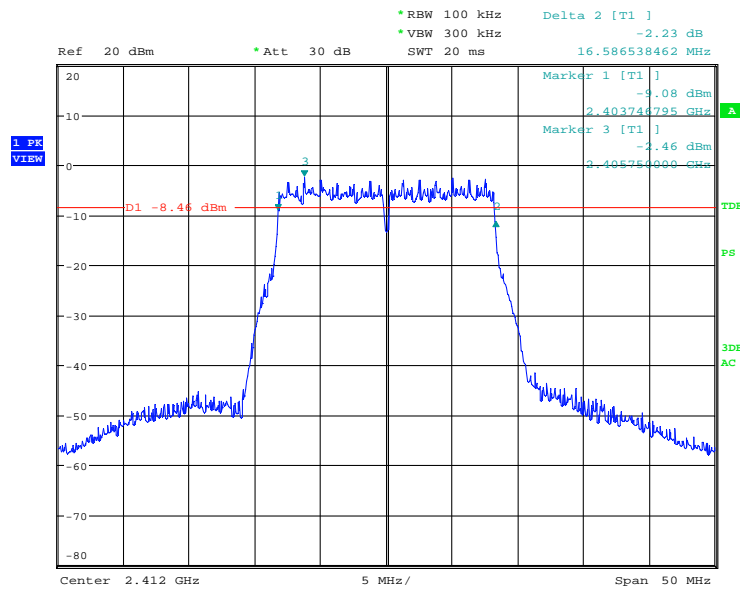

6dB bandwidth, mode 11g, 2412MHz
 Date: 2.NOV.2015 17:54:04

Figure 6: 6dB Bandwidth, Mode B (2437MHz), 11g_Antenna 0

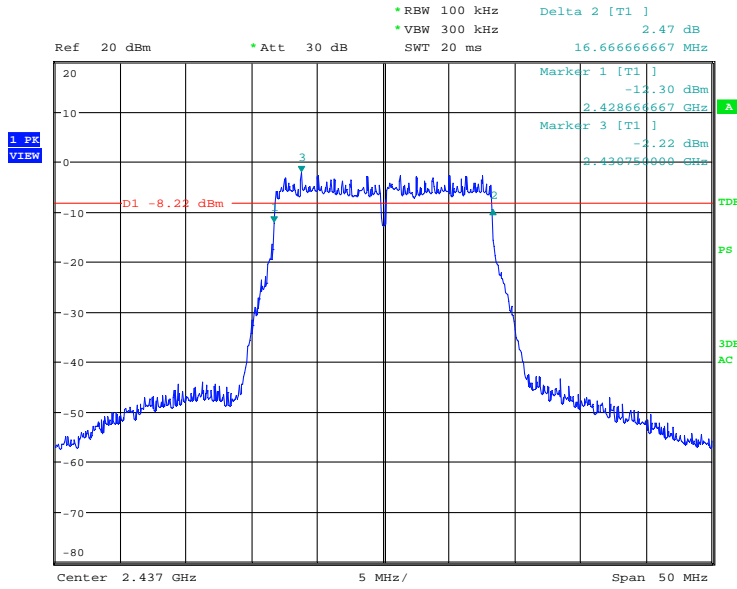

6dB bandwidth, mode 11g, 2437MHz
Date: 2.NOV.2015 17:15:25

Figure 7: 6dB Bandwidth, Mode C (2462MHz), 11g_Antenna 0

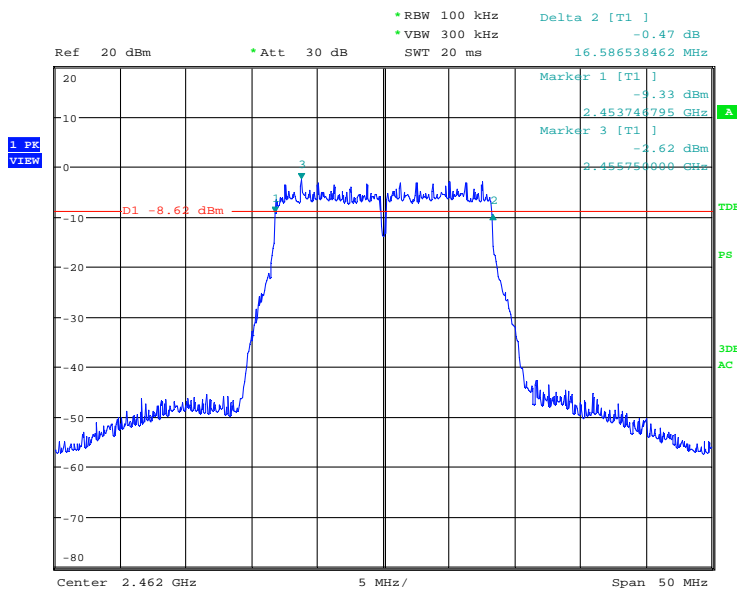

6dB bandwidth, mode 11g, 2462MHz
Date: 2.NOV.2015 17:36:51

Table 12: 6dB Bandwidth, 11n(20HT)_Antenna 0

Operating Frequency [MHz]	6dB Bandwidth [MHz]	Limit [MHz]
2412	17.78	0.5
2437	17.78	0.5
2462	17.78	0.5

Figure 8: 6dB Bandwidth, Mode A (2412MHz), 11n(20HT)_Antenna 0

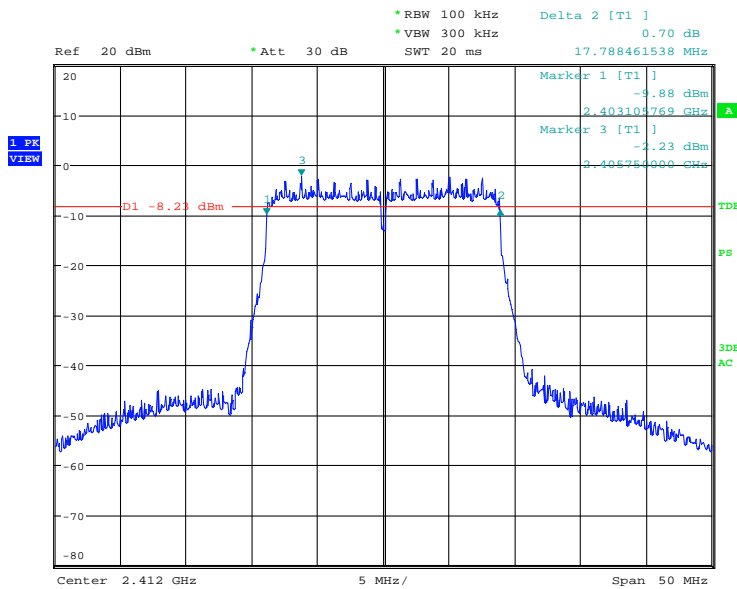

6dB bandwidth, mode 11n(20HT), 2412MHz
Date: 2.NOV.2015 17:50:15

Figure 9: 6dB Bandwidth, Mode B (2437MHz), 11n(20HT)_Antenna 0

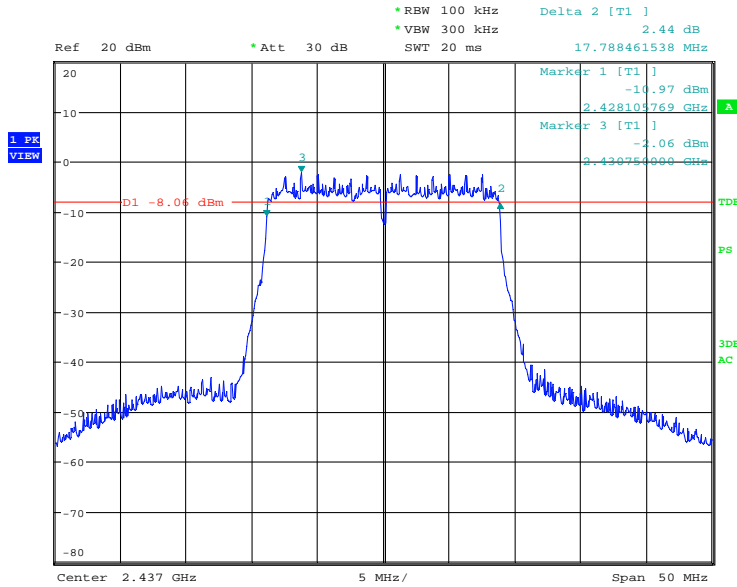

6dB bandwidth, mode 11n(20HT), 2437MHz
Date: 2.NOV.2015 17:45:24

Figure 10: 6dB Bandwidth, Mode C (2462MHz), 11n(20HT)_Antenna 0

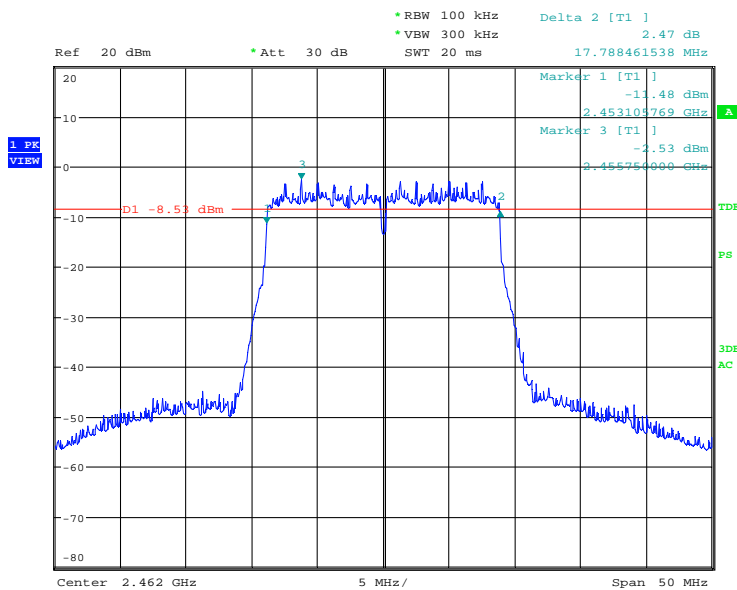

6dB bandwidth, mode 11n(20HT), 2462MHz
Date: 2.NOV.2015 17:41:19

Table 13: 6dB Bandwidth, 11n(20HT)_Antenna 1

Operating Frequency [MHz]	6dB Bandwidth [MHz]	Limit [MHz]
2412	17.78	0.5
2437	17.86	0.5
2462	17.78	0.5

Figure 11: 6dB Bandwidth, Mode A (2412MHz), 11n(20HT)_Antenna 1

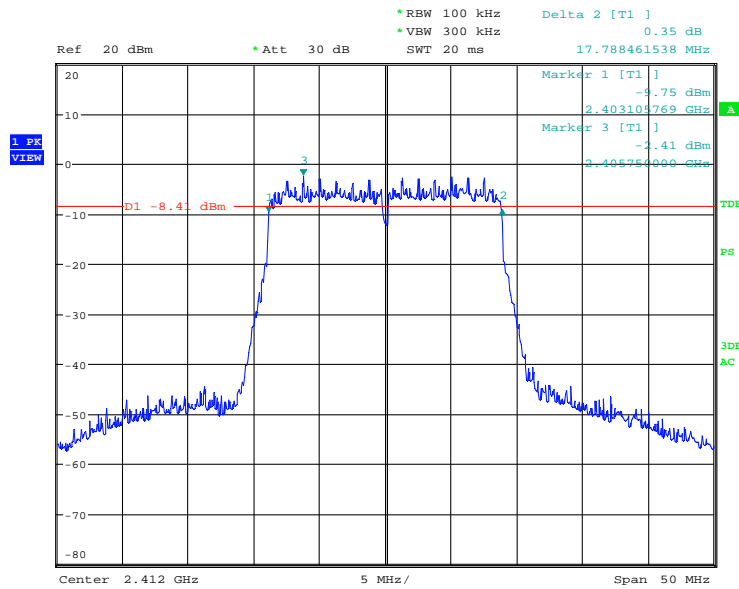

6dB bandwidth, mode 11n(20HT), 2412MHz, Ant1
Date: 2.NOV.2015 18:25:31

Figure 12: 6dB Bandwidth, Mode B (2437MHz), 11n(20HT)_Antenna 1

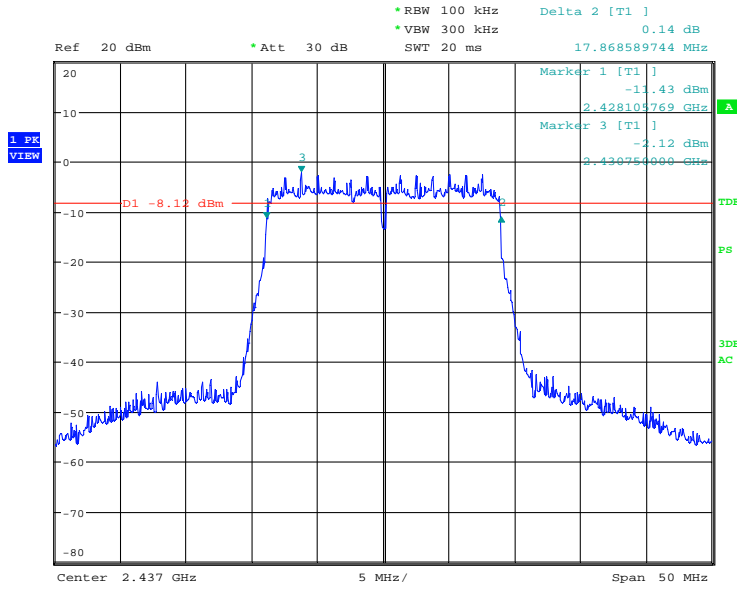

6dB bandwidth, mode 11n(20HT), 2437MHz, Ant1
Date: 2.NOV.2015 18:27:52

Figure 13: 6dB Bandwidth, Mode C (2462MHz), 11n(20HT)_Antenna 1

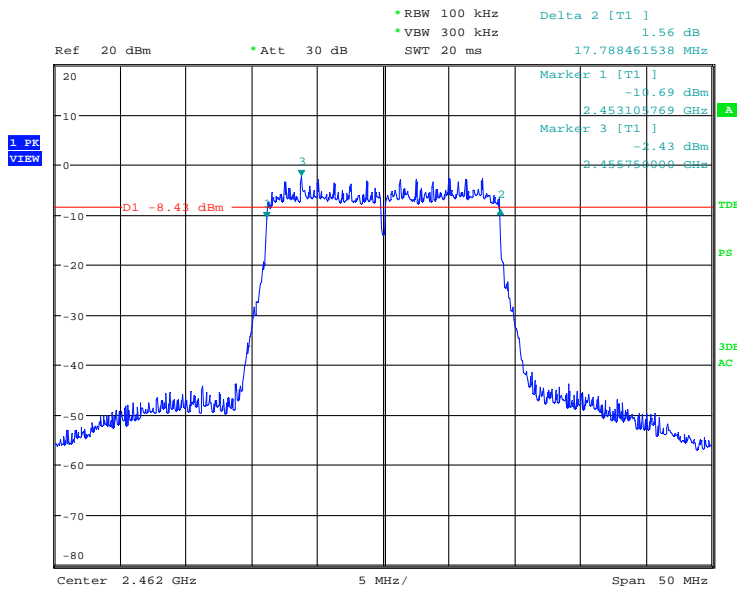

6dB bandwidth, mode 11n(20HT), 2462MHz, Ant1
Date: 2.NOV.2015 18:30:00

Table 14: 6dB Bandwidth, 11n(40HT)_Antenna 0

Operating Frequency [MHz]	6dB Bandwidth [MHz]	Limit [MHz]
2422	36.53	0.5
2447	36.53	0.5
2452	36.45	0.5

Figure 14: 6dB Bandwidth, Mode A (2422MHz), 11n(40HT)_Antenna 0

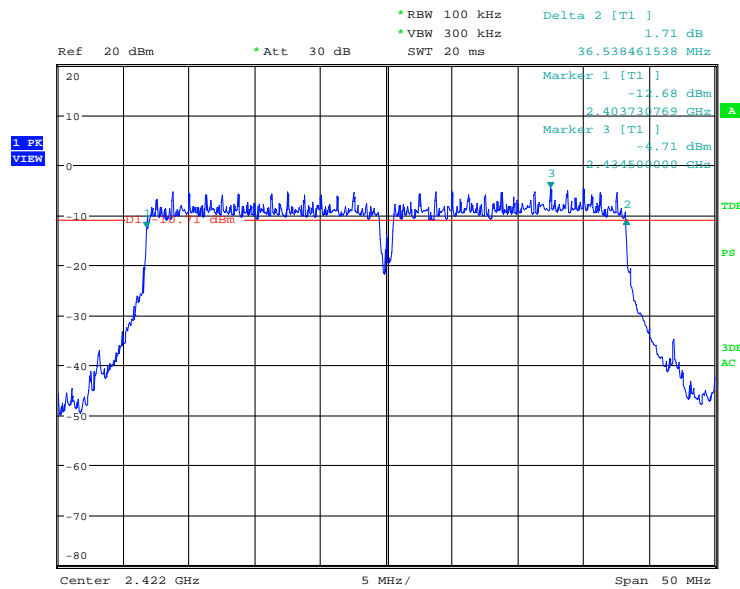

6dB bandwidth, mode 11n(40HT), 2422MHz
 Date: 2.NOV.2015 18:03:37

Figure 15: 6dB Bandwidth, Mode B (2447MHz), 11n(40HT)_Antenna 0

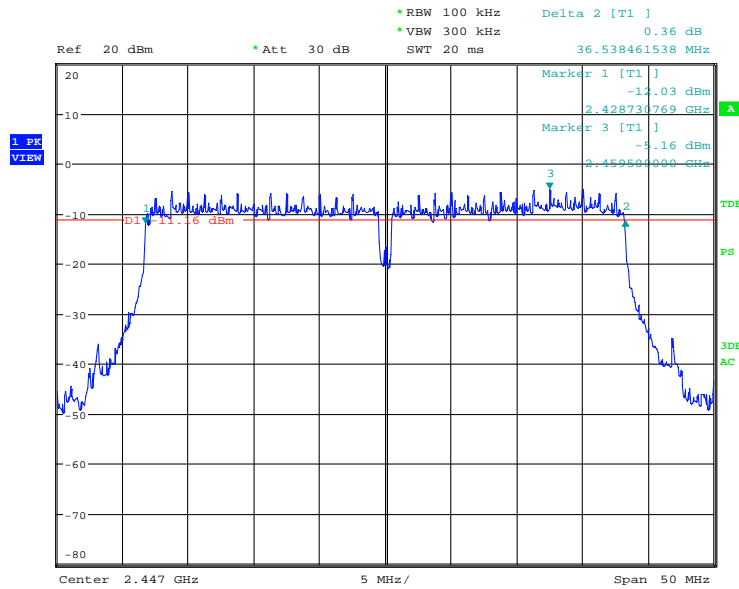

6dB bandwidth, mode 11n(40HT), 2447MHz
Date: 2.NOV.2015 18:09:40

Figure 16: 6dB Bandwidth, Mode C (2452MHz), 11n(40HT)_Antenna 0

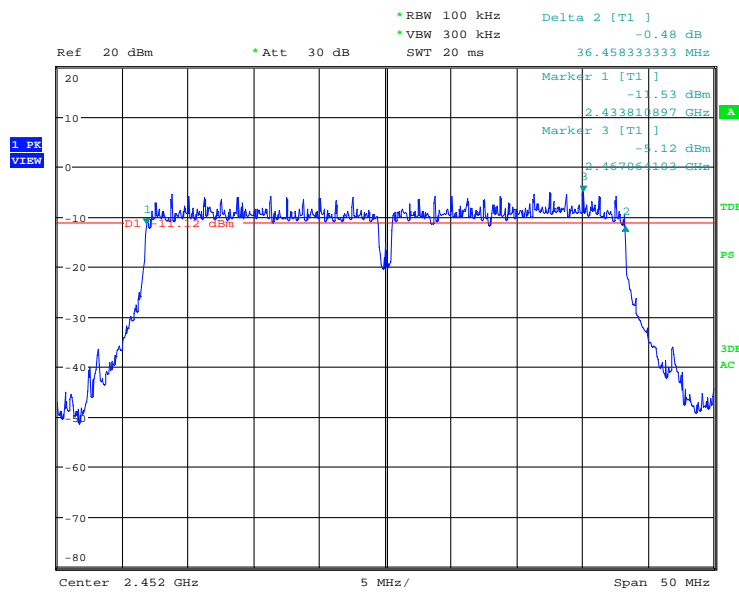

6dB bandwidth, mode 11n(40HT), 2452MHz
Date: 2.NOV.2015 18:12:24

Table 15: 6dB Bandwidth, 11n(40HT)_Antenna 1

Operating Frequency [MHz]	6dB Bandwidth [MHz]	Limit [MHz]
2422	36.61	0.5
2447	36.53	0.5
2452	36.45	0.5

Figure 17: 6dB Bandwidth, Mode A (2422MHz), 11n(40HT)_Antenna 1

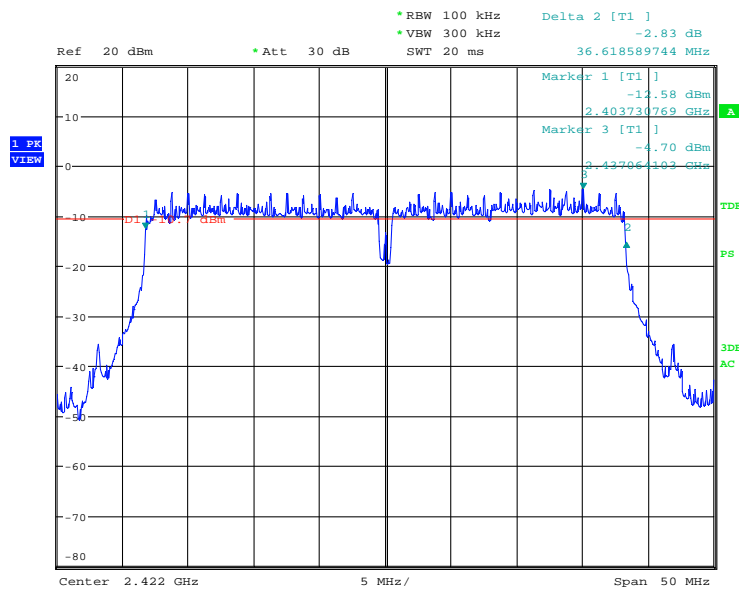

6dB bandwidth, mode 11n(40HT), 2422MHz, Ant1
Date: 2.NOV.2015 18:21:31

Figure 18: 6dB Bandwidth, Mode B (2447MHz), 11n(40HT)_Antenna 1

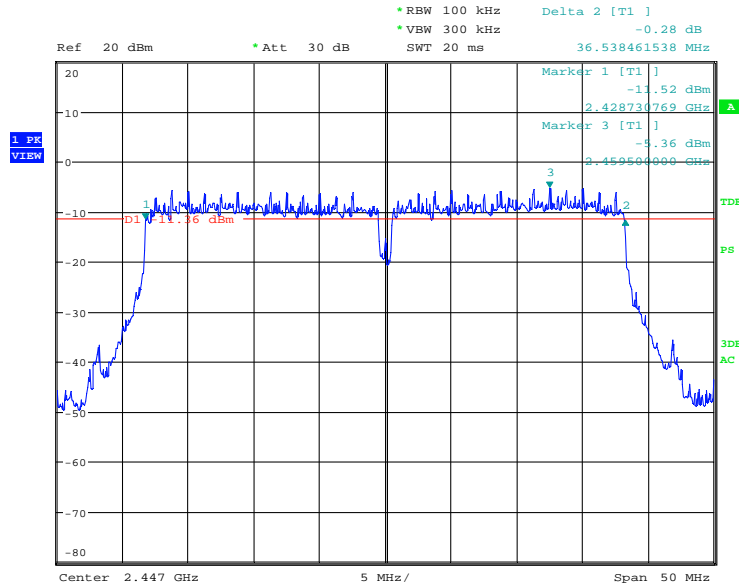

6dB bandwidth, mode 11n(40HT), 2447MHz, Ant1
Date: 2.NOV.2015 18:18:44

Figure 19: 6dB Bandwidth, Mode C (2452MHz), 11n(40HT)_Antenna 1

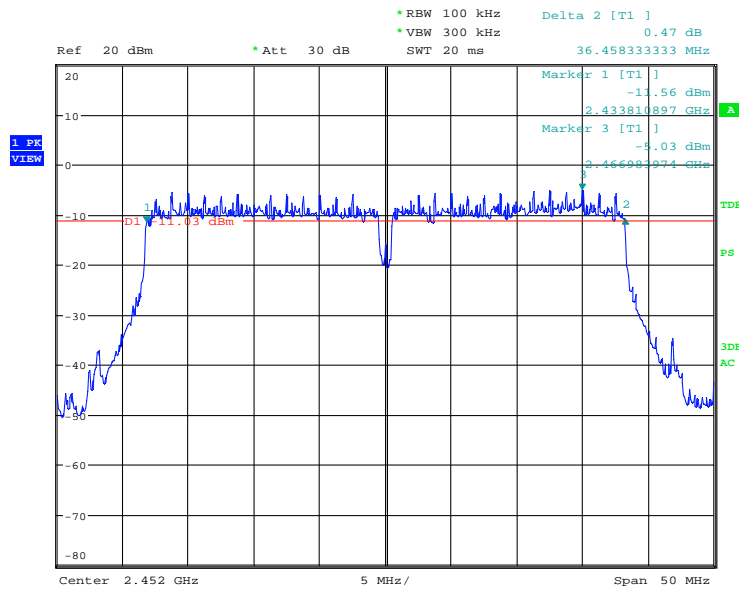

6dB bandwidth, mode 11n(40HT), 2452MHz, Ant1
Date: 2.NOV.2015 18:16:01

Prüfbericht - Nr.: 50027424 001**Seite 32 von 123**

Test Report No.:

Page 32 of 123

5.2.3 99% Bandwidth

Date of testing: 2015-11-02

Ambient temperature: 24°C

Relative humidity: 46%

Atmospheric pressure: 1012hPa

Requirements:

RSS-Gen 6.6

The 99% bandwidth shall be reported according to RSS-Gen 6.6.

Test procedure:

RSS-Gen 6.6

Measurements were taken using both antenna 0 and antenna 1. The measurements were performed using a spectrum analyzer with the resolution bandwidth (RBW) set in the range of 1% to 5% of the occupied bandwidth (OBW) and the video bandwidth (VBW) set to approximately $3 \times \text{RBW}$. The 99% bandwidth was measured by using the OBW function of the analyzer with a 99% coverage setting.

For protocols IEEE 802.11b and g, measurements were done on antenna 0, selected as representative antenna.

Table 16: 99% Bandwidth, 11b_Antenna 0

Operating Frequency [MHz]	99% Bandwidth [MHz]
2412MHz	11.38
2437MHz	11.30
2464MHz	11.22

Figure 20: 99% Bandwidth, Mode A (2412MHz), 11b_Antenna 0

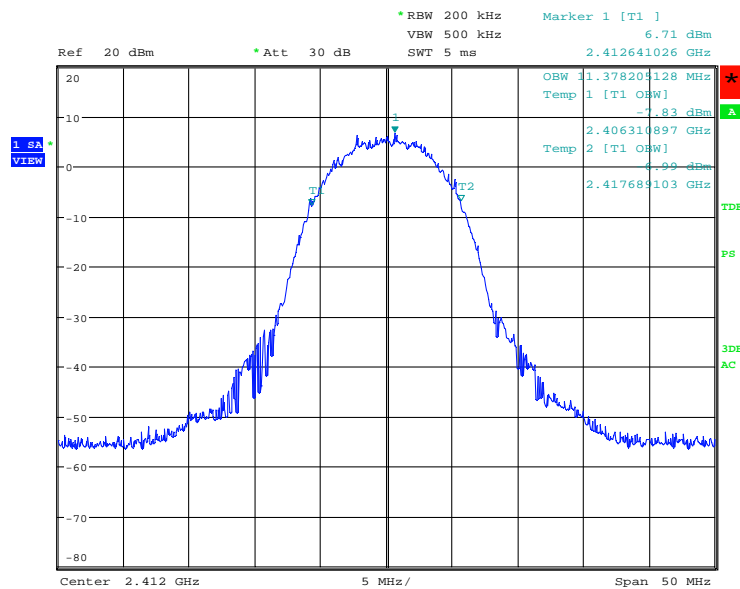

99% bandwidth, mode 11b, 2412MHz
Date: 2.NOV.2015 16:43:26

Figure 21: 99% Bandwidth, Mode B (2437MHz), 11b_Antenna 0

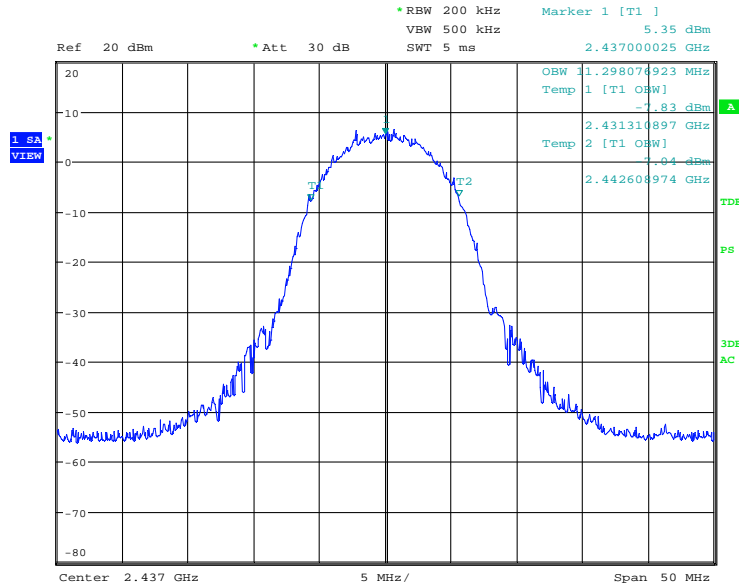

99% bandwidth, mode 11b, 2437MHz
 Date: 2.NOV.2015 16:55:50

Figure 22: 99% Bandwidth, Mode C (2462MHz), 11b_Antenna 0

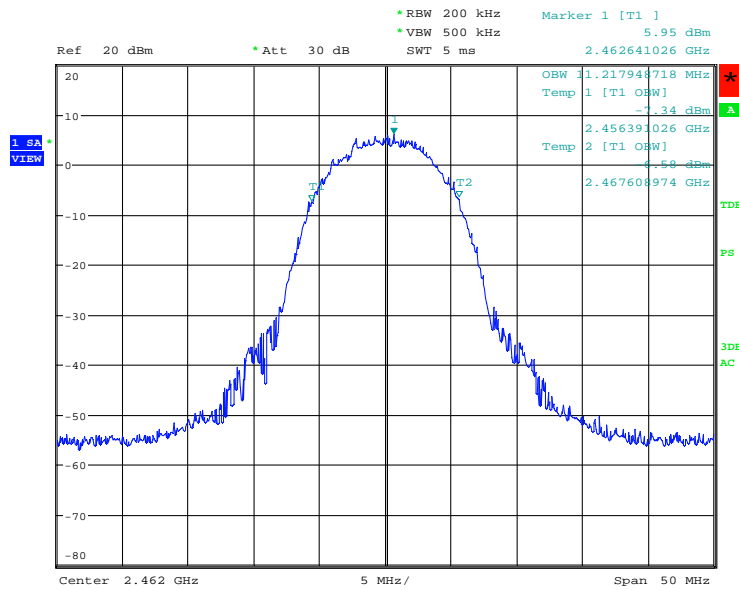

99% bandwidth, mode 11b, 2462MHz
 Date: 2.NOV.2015 17:03:30

Table 17: 99% Bandwidth, 11g_Antenna 0

Operating Frequency [MHz]	99% Bandwidth [MHz]
2412MHz	16.51
2437MHz	16.51
2464MHz	16.67

Figure 23: 99% Bandwidth, Mode A (2412MHz), 11g_Antenna 0

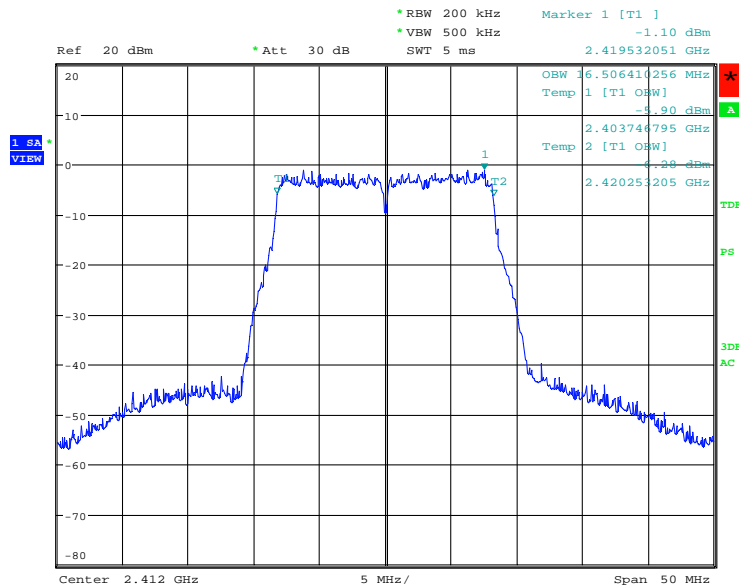

99% bandwidth, mode 11g, 2412MHz
Date: 2.NOV.2015 17:54:23

Figure 24: 99% Bandwidth, Mode B (2437MHz), 11g_Antenna 0

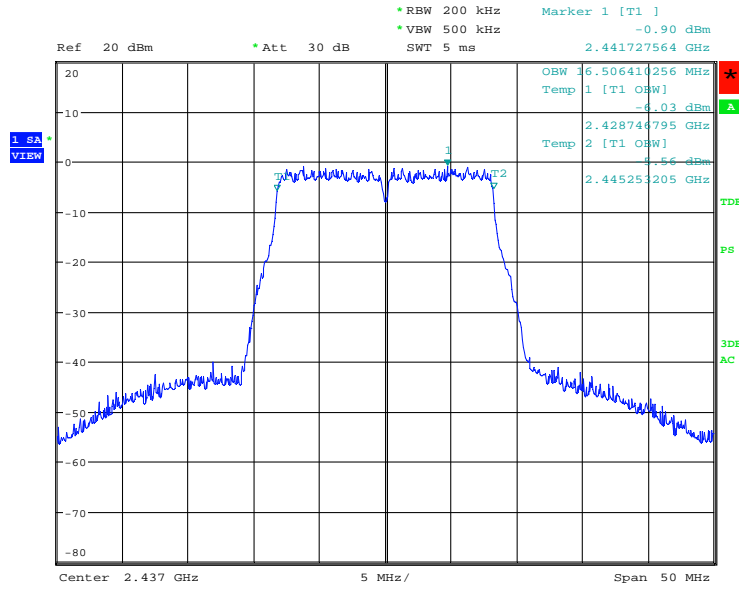

99% bandwidth, mode 11g, 2437MHz
Date: 2.NOV.2015 17:16:18

Figure 25: 99% Bandwidth, Mode C (2462MHz), 11g_Antenna 0

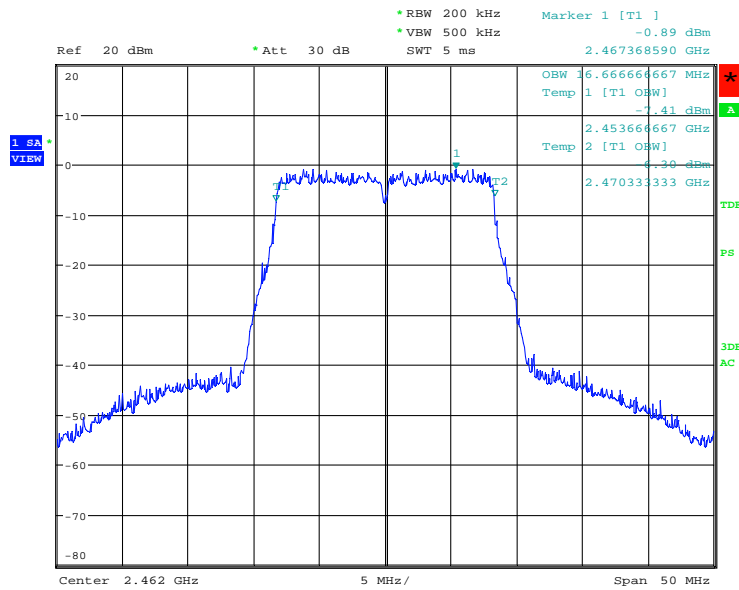

99% bandwidth, mode 11g, 2462MHz
Date: 2.NOV.2015 17:37:52

Table 18: 99% Bandwidth, 11n(20HT)_Antenna 0

Operating Frequency [MHz]	99% Bandwidth [MHz]
2412MHz	17.63
2437MHz	17.63
2464MHz	17.63

Figure 26: 99% Bandwidth, Mode A (2412MHz), 11n(20HT)_Antenna 0

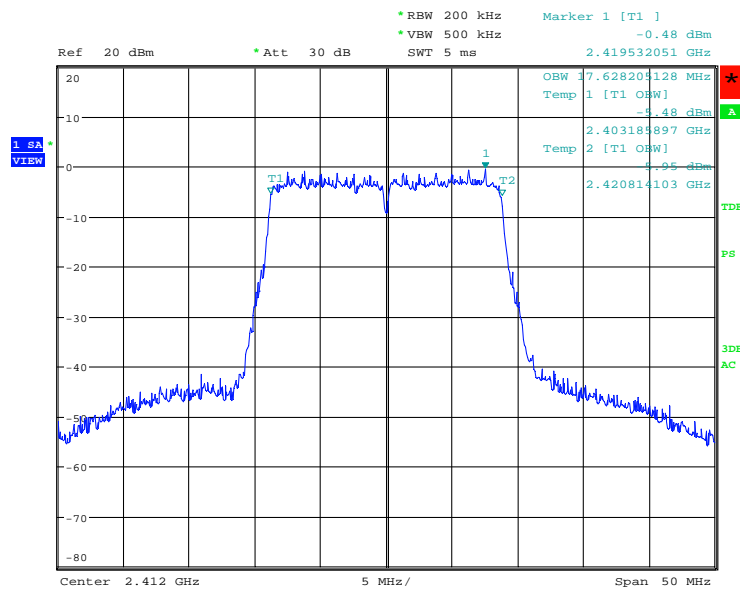

99% bandwidth, mode 11n(20HT), 2412MHz
Date: 2.NOV.2015 17:50:41

Figure 27: 99% Bandwidth, Mode B (2437MHz), 11n(20HT)_Antenna 0

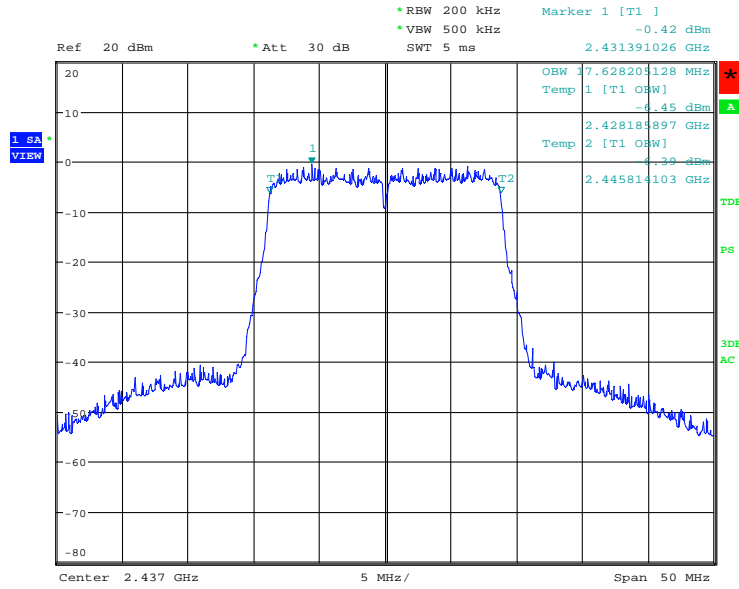

99% bandwidth, mode 11n(20HT), 2437MHz
Date: 2.NOV.2015 17:47:22

Figure 28: 99% Bandwidth, Mode C (2462MHz), 11n(20HT)_Antenna 0

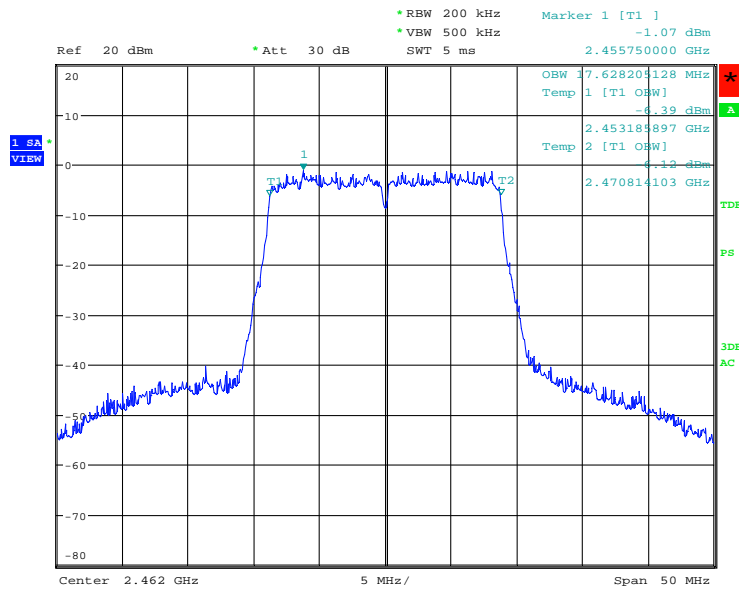

99% bandwidth, mode 11n(20HT), 2462MHz
Date: 2.NOV.2015 17:42:34

Table 19: 99% Bandwidth, 11n(20HT)_Antenna 1

Operating Frequency [MHz]	99% Bandwidth [MHz]
2412MHz	17.63
2437MHz	17.63
2464MHz	17.63

Figure 29: 99% Bandwidth, Mode A (2412MHz), 11n(20HT)_Antenna 1

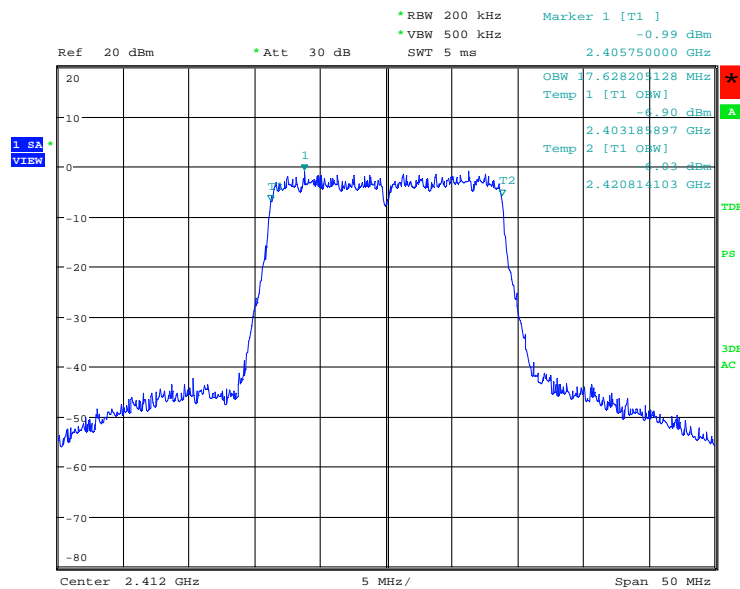

99% bandwidth, mode 11n(20HT), 2412MHz, Ant1
Date: 2.NOV.2015 18:25:53

Figure 30: 99% Bandwidth, Mode B (2437MHz), 11n(20HT)_Antenna 1

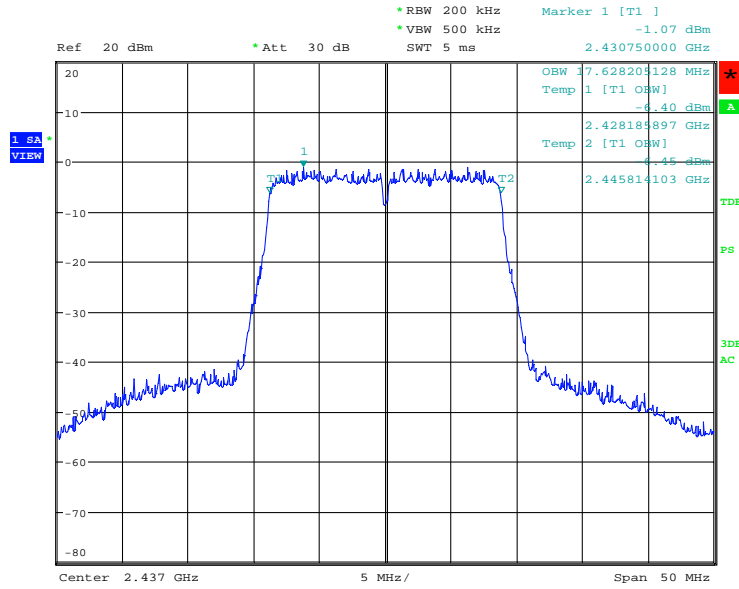

99% bandwidth, mode 11n(20HT), 2437MHz, Ant1
Date: 2.NOV.2015 18:28:12

Figure 31: 99% Bandwidth, Mode C (2462MHz), 11n(20HT)_Antenna 1

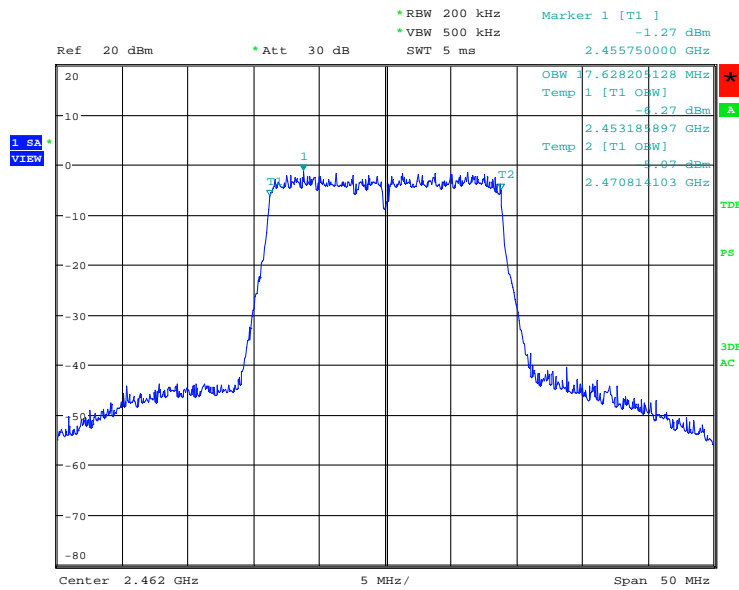

99% bandwidth, mode 11n(20HT), 2462MHz, Ant1
Date: 2.NOV.2015 18:30:17

Table 20: 99% Bandwidth, 11n(40HT)_Antenna 0

Operating Frequency [MHz]	99% Bandwidth [MHz]
2422MHz	36.22
2437MHz	36.38
2452MHz	36.38

Figure 32: 99% Bandwidth, Mode A (2422MHz), 11n(40HT)_Antenna 0

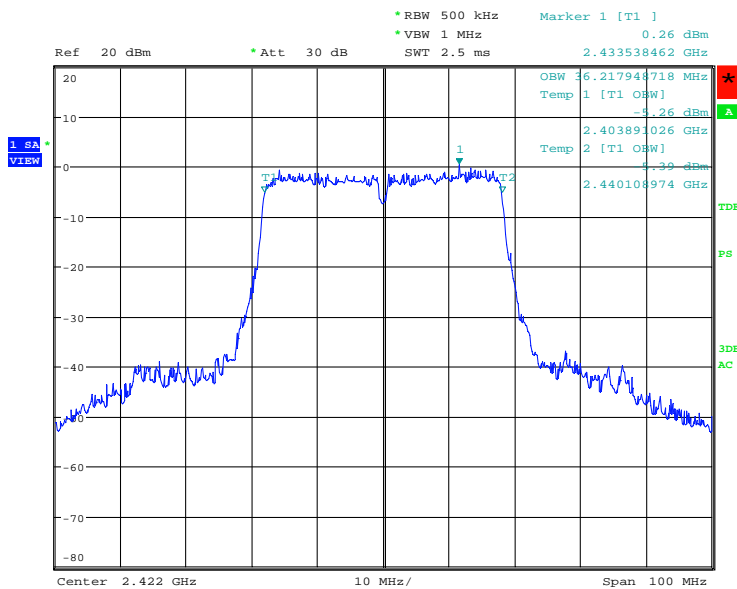

99% bandwidth, mode 11n(40HT), 2422MHz
Date: 2.NOV.2015 18:06:46

Figure 33: 99% Bandwidth, Mode B (2447MHz), 11n(40HT)_Antenna 0

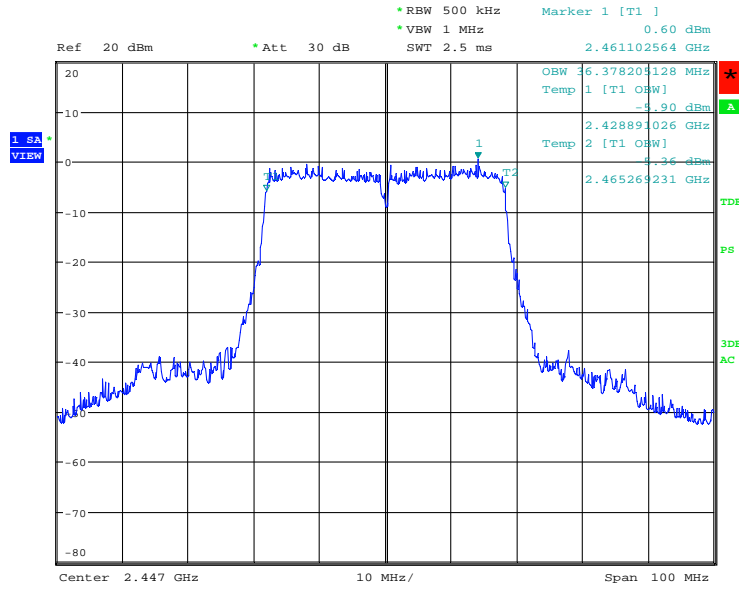

99% bandwidth, mode 11n(40HT), 2447MHz
Date: 2.NOV.2015 18:10:02

Figure 34: 99% Bandwidth, Mode C (2452MHz), 11n(40HT)_Antenna 0

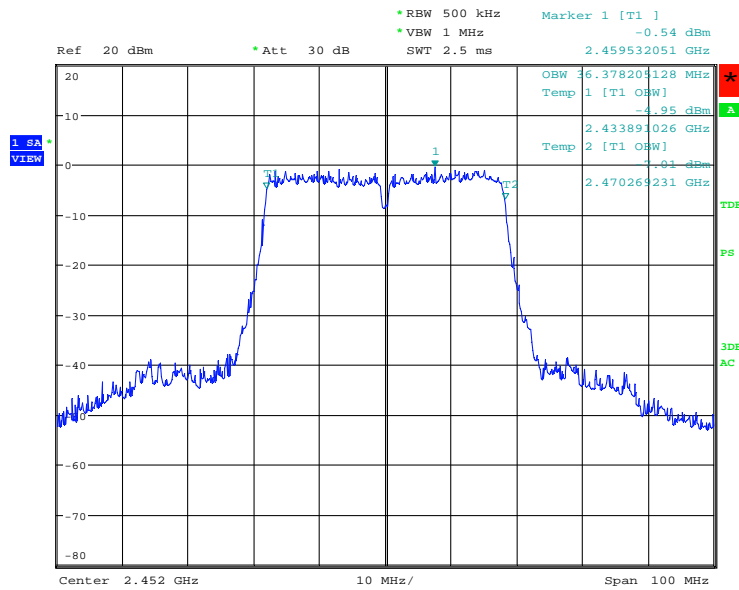

99% bandwidth, mode 11n(40HT), 2452MHz
Date: 2.NOV.2015 18:12:46

Table 21: 99% Bandwidth, 11n(40HT)_Antenna 1

Operating Frequency [MHz]	99% Bandwidth [MHz]
2422MHz	36.22
2447MHz	36.54
2452MHz	36.22

Figure 35: 99% Bandwidth, Mode A (2422MHz), 11n(40HT)_Antenna 1

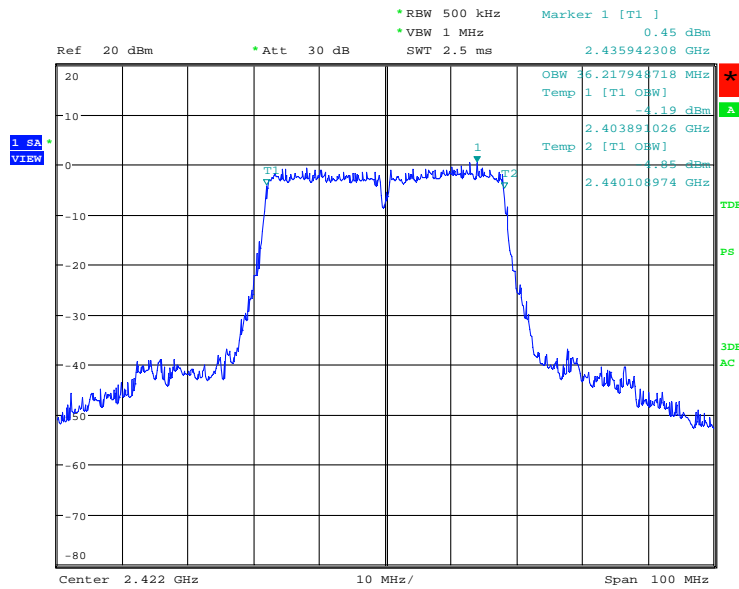

99% bandwidth, mode 11n(40HT), 2422MHz, Ant1
 Date: 2.NOV.2015 18:21:49

Figure 36: 99% Bandwidth, Mode B (2447MHz), 11n(40HT)_Antenna 1

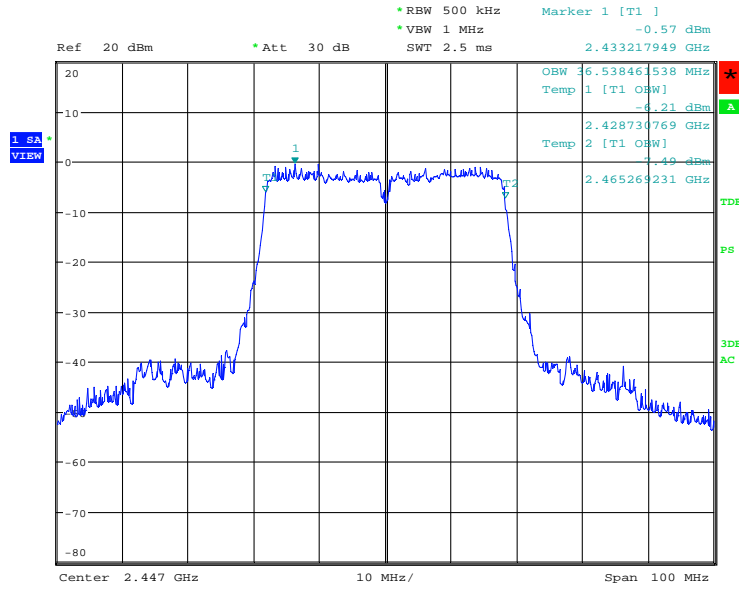

99% bandwidth, mode 11n(40HT), 2447MHz, Ant1
Date: 2.NOV.2015 18:19:04

Figure 37: 99% Bandwidth, Mode C (2452MHz), 11n(40HT)_Antenna 1

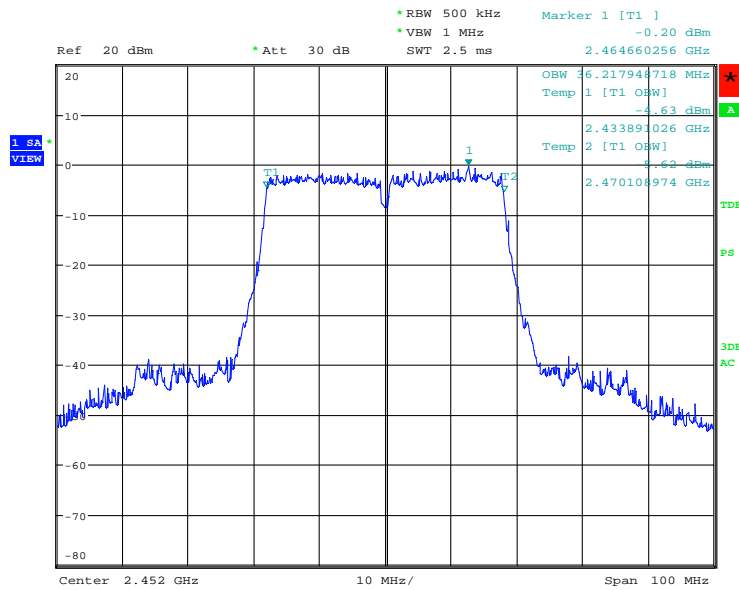

99% bandwidth, mode 11n(40HT), 2452MHz, Ant1
Date: 2.NOV.2015 18:16:25

5.2.4 Conducted Spurious Emissions

RESULT:
PASS

Date of testing: 2015-11-02
 Ambient temperature: 24°C
 Relative humidity: 46%
 Atmospheric pressure: 1012hPa

Requirements:

FCC 15.247(d) and RSS-247 5.5

In any 100kHz bandwidth outside the frequency band in which the intentional radiator is operating, the RF power shall be at least 20dB below that of the maximum in-band 100kHz emission.

Test procedure:

ANSI C63.10-2013, RSS-Gen 6.13 and KDB Publication No. 558074 D01.

The conducted spurious emissions were measured at the antenna port with a spectrum analyzer using a peak detector. The resolution bandwidth was set to 100kHz and the video bandwidth to 300kHz. Measurements were performed from 30MHz to 25GHz (10th harmonics).

The readings of the measurements take into account the loss generated by all the involved cables.

Table 22: Conducted Spurious Emissions in Non-Restricted Frequency Bands

Protocol	Antenna Port for Final Measurement	Frequency [MHz]	Worst Case Margin [dB]
11b	Antenna 0 (*)	2412	>20dB
11b	Antenna 0 (*)	2437	>20dB
11b	Antenna 0 (*)	2462	>20dB
11g	Antenna 0 (*)	2412	>20dB
11g	Antenna 0 (*)	2437	>20dB
11g	Antenna 0 (*)	2462	>20dB
11n(20HT)	Antenna 0 (*)	2412	>20dB
11n(20HT)	Antenna 0 (*)	2437	>20dB
11n(20HT)	Antenna 0 (*)	2462	>20dB
11n(40HT)	Antenna 0 (*)	2422	>20dB
11n(40HT)	Antenna 0 (*)	2447	>20dB
11n(40HT)	Antenna 0 (*)	2457	>20dB

(*) Antenna 0 was worst case for result.

Figure 38: Conducted Spurious Emissions in Non-Restricted Frequency Bands, 30MHz - 25GHz, Mode A (2412MHz), 11b_Antenna 0

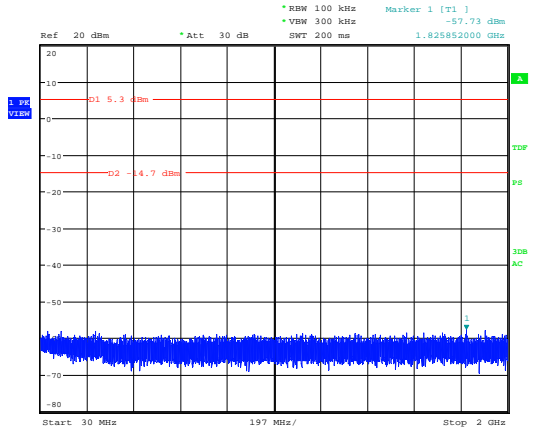

Conducted spurious emissions, mode 11b, 2412MHz
Date: 2.NOV.2015 19:35:59

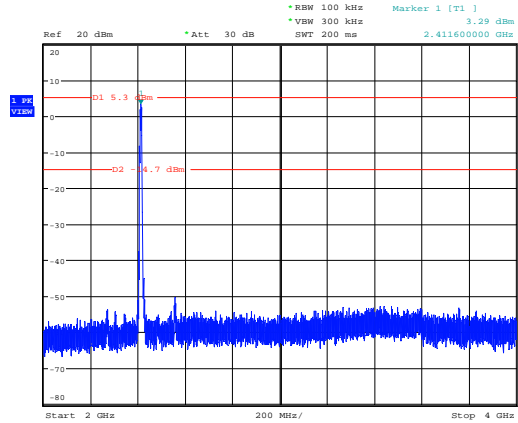

Conducted spurious emissions, mode 11b, 2412MHz
Date: 2.NOV.2015 19:37:01

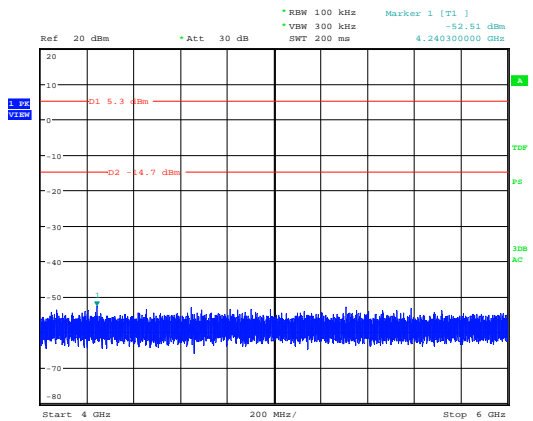

Conducted spurious emissions, mode 11b, 2412MHz
Date: 2.NOV.2015 19:37:33

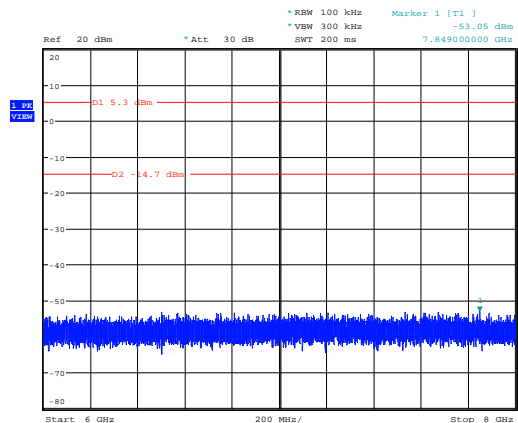

Conducted spurious emissions, mode 11b, 2412MHz
Date: 2.NOV.2015 19:37:54

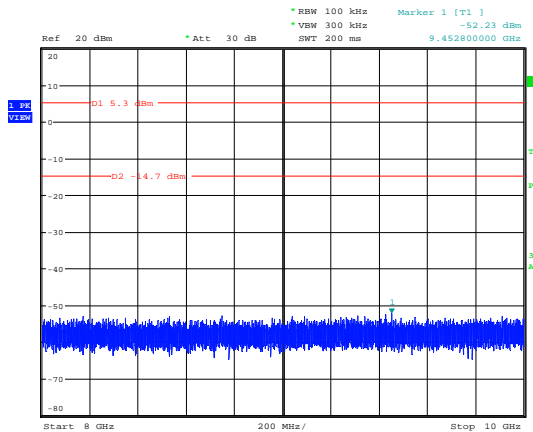

Conducted spurious emissions, mode 11b, 2412MHz
Date: 2.NOV.2015 19:38:20

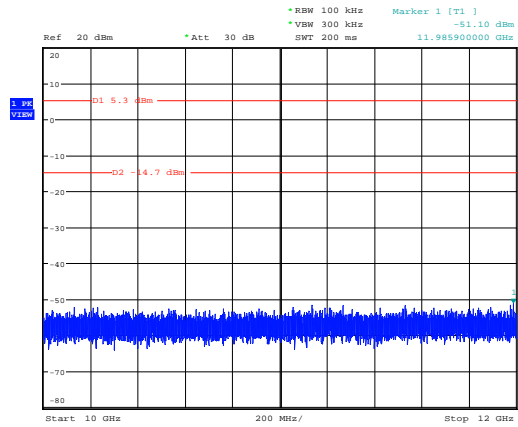

Conducted spurious emissions, mode 11b, 2412MHz
Date: 2.NOV.2015 19:38:55

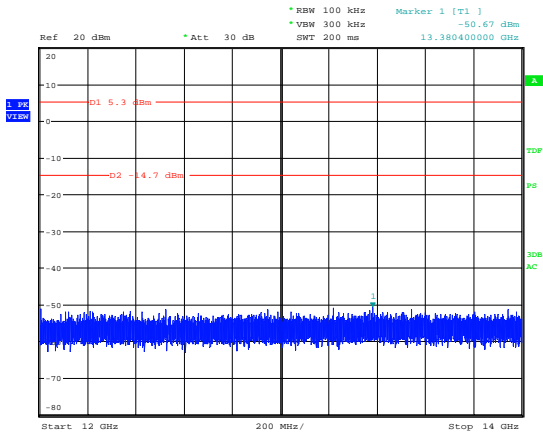

Conducted spurious emissions, mode 11b, 2412MHz
Date: 2.NOV.2015 19:39:30

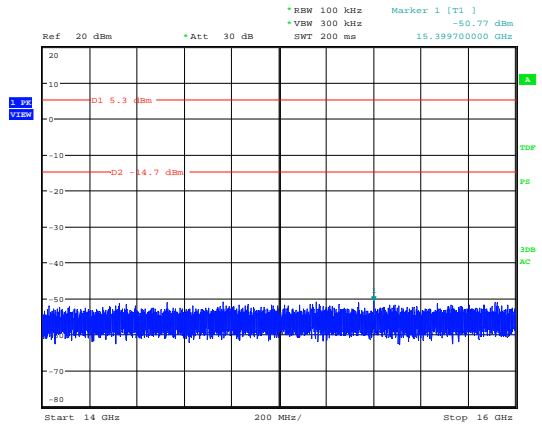

Conducted spurious emissions, mode 11b, 2412MHz
Date: 2.NOV.2015 19:40:25

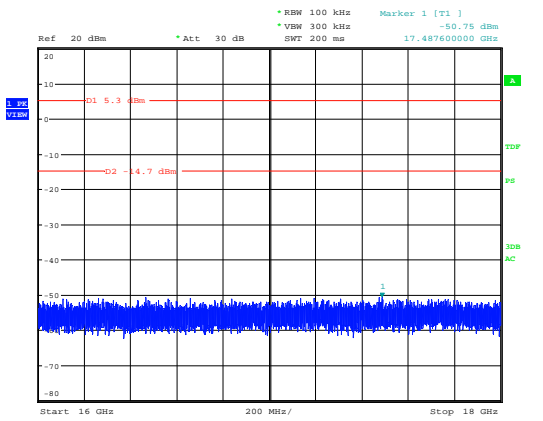

Conducted spurious emissions, mode 11b, 2412MHz
Date: 2.NOV.2015 19:40:48

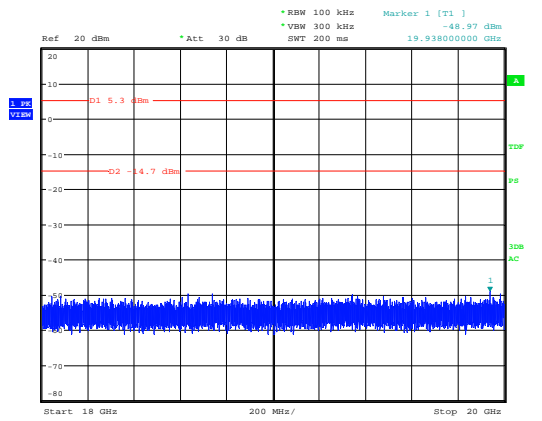

Conducted spurious emissions, mode 11b, 2412MHz
Date: 2.NOV.2015 19:41:22

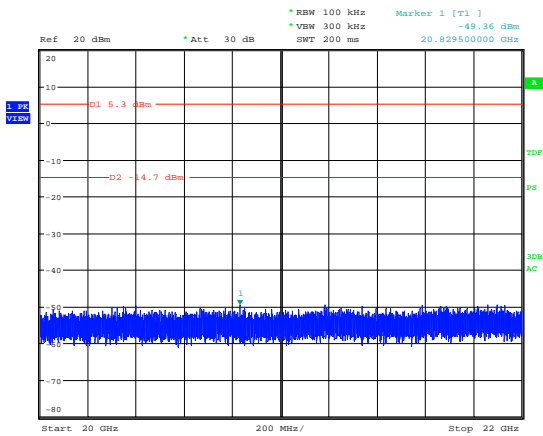

Conducted spurious emissions, mode 11b, 2412MHz
Date: 2.NOV.2015 19:41:57

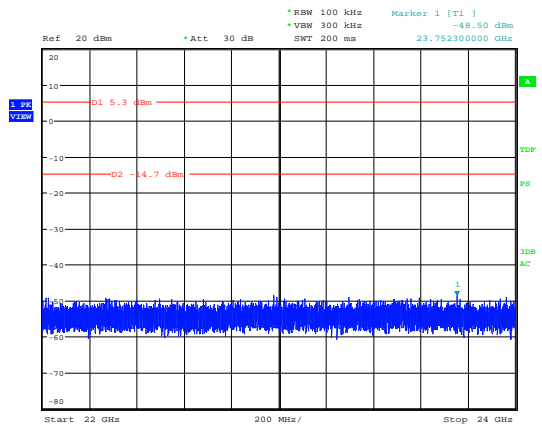

Conducted spurious emissions, mode 11b, 2412MHz
Date: 2.NOV.2015 19:42:30

Produkte
Products

Prüfbericht - Nr.: 50027424 001
Test Report No.:

Seite 48 von 123
Page 48 of 123

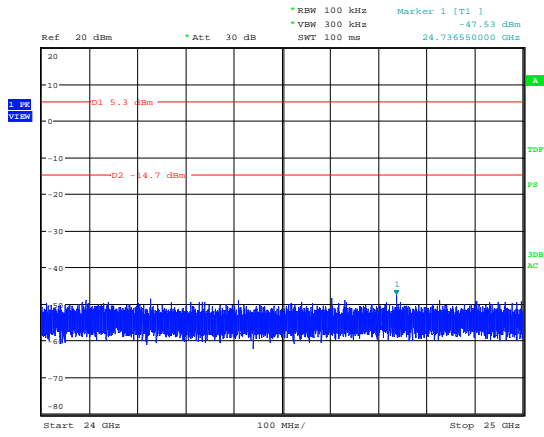

Conducted spurious emissions, mode 11b, 2412MHz
Date: 2.NOV.2015 19:42:54

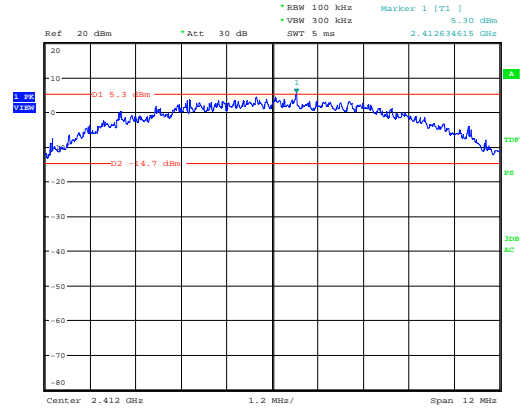

Conducted spurious emissions, mode 11b, 2412MHz
Date: 2.NOV.2015 19:35:21

Figure 39: Conducted Spurious Emissions in Non-Restricted Frequency Bands, 30MHz - 25GHz, Mode B (2437MHz), 11b_Antenna 0

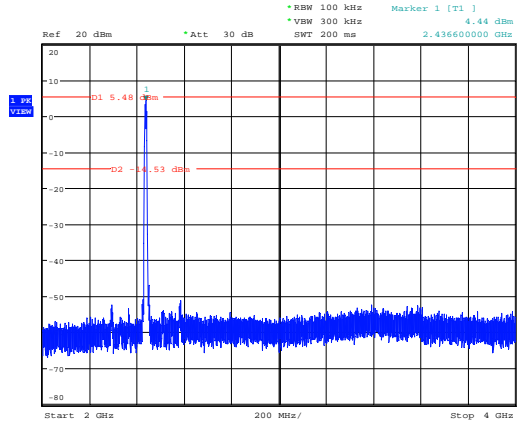
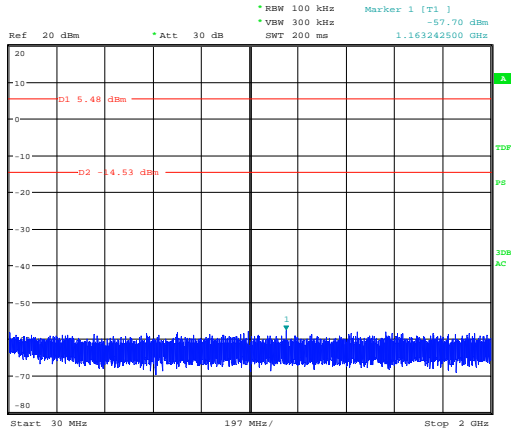

Conducted spurious emissions, mode 11b, 2437MHz
Date: 2.NOV.2015 19:27:30

Conducted spurious emissions, mode 11b, 2437MHz
Date: 2.NOV.2015 19:27:58

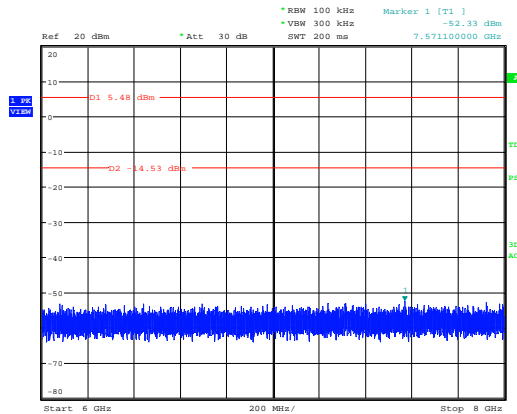
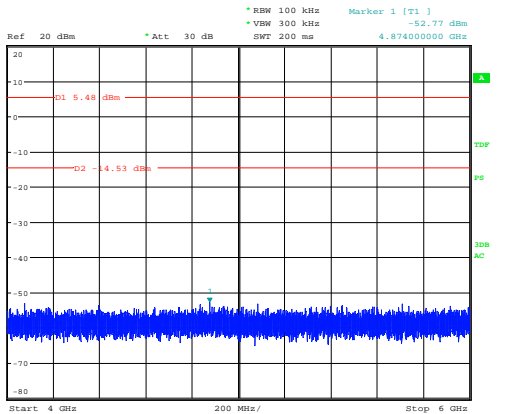

Conducted spurious emissions, mode 11b, 2437MHz
Date: 2.NOV.2015 19:28:32

Conducted spurious emissions, mode 11b, 2437MHz
Date: 2.NOV.2015 19:29:14

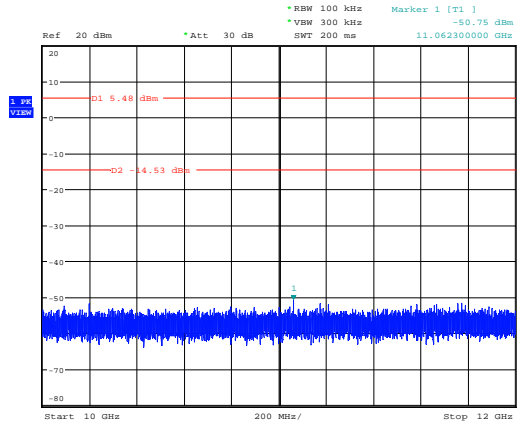
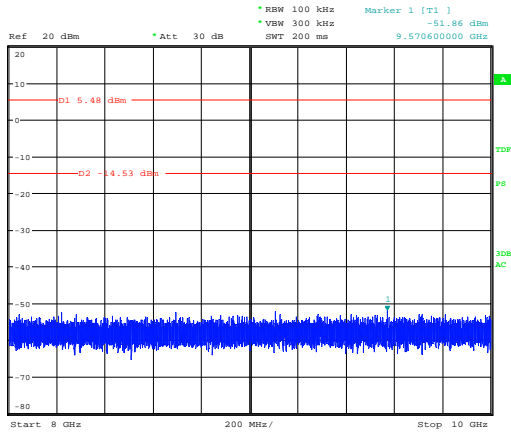

Conducted spurious emissions, mode 11b, 2437MHz
Date: 2.NOV.2015 19:29:46

Conducted spurious emissions, mode 11b, 2437MHz
Date: 2.NOV.2015 19:30:34

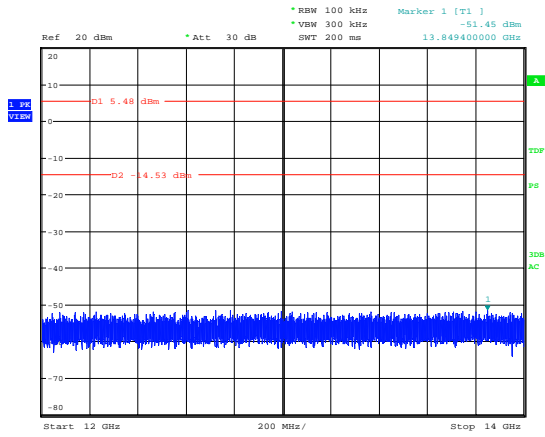

Conducted spurious emissions, mode 11b, 2437MHz
Date: 2.NOV.2015 19:31:04

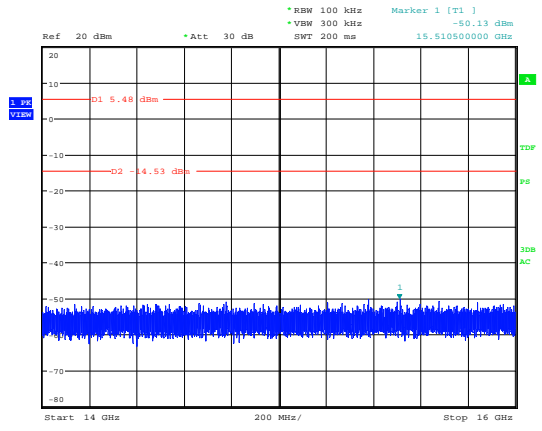

Conducted spurious emissions, mode 11b, 2437MHz
Date: 2.NOV.2015 19:31:51

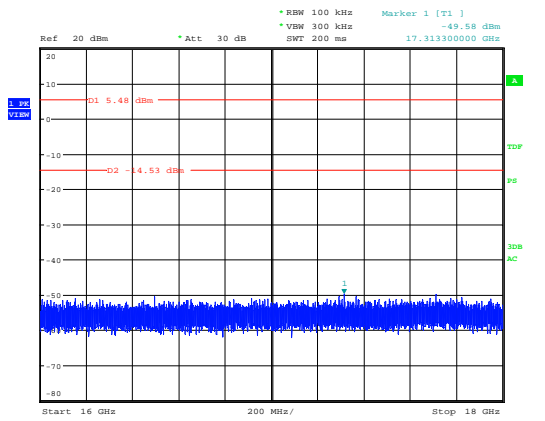

Conducted spurious emissions, mode 11b, 2437MHz
Date: 2.NOV.2015 19:32:13

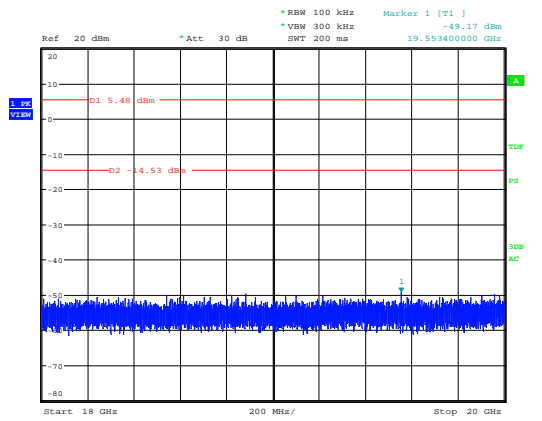

Conducted spurious emissions, mode 11b, 2437MHz
Date: 2.NOV.2015 19:32:35

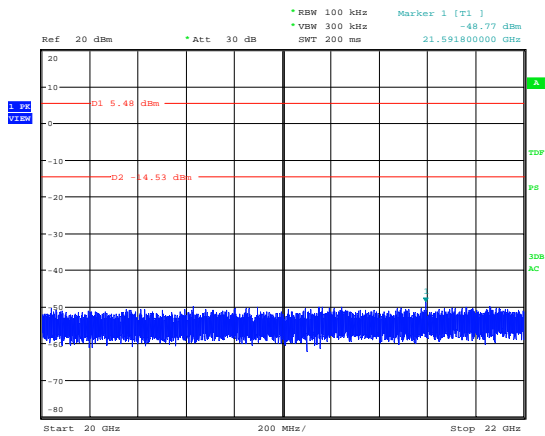

Conducted spurious emissions, mode 11b, 2437MHz
Date: 2.NOV.2015 19:33:07

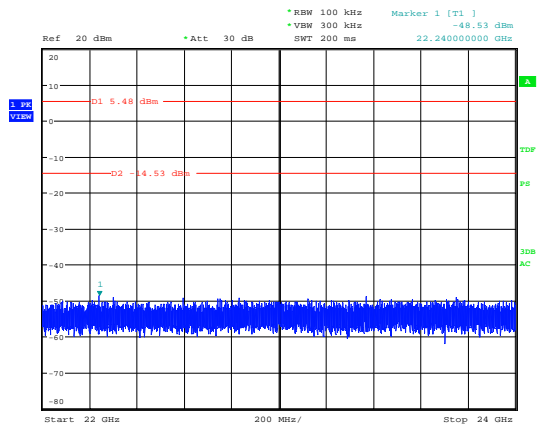

Conducted spurious emissions, mode 11b, 2437MHz
Date: 2.NOV.2015 19:33:34

Produkte
Products

Prüfbericht - Nr.: 50027424 001
Test Report No.:

Seite 51 von 123
Page 51 of 123

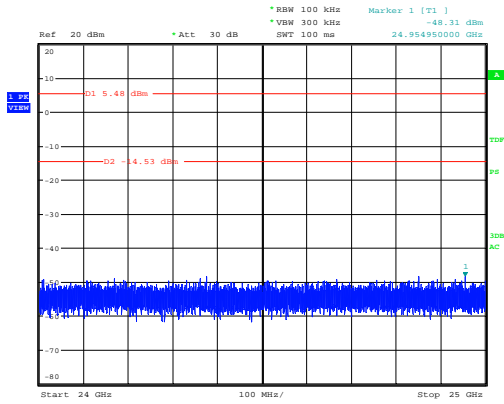

Conducted spurious emissions, mode 11b, 2437MHz
Date: 2.NOV.2015 19:33:51

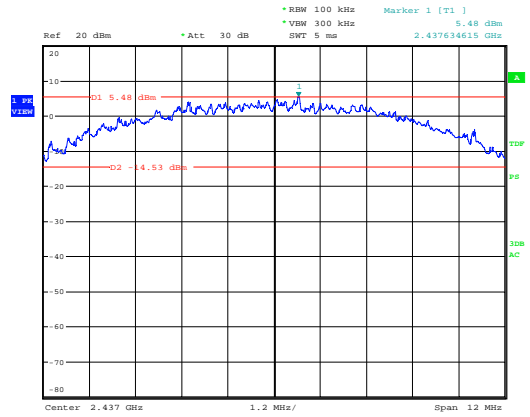

Conducted spurious emissions, mode 11b, 2437MHz
Date: 2.NOV.2015 19:27:14

Figure 40: Conducted Spurious Emissions in Non-Restricted Frequency Bands, 30MHz - 25GHz, Mode C (2462MHz), 11b_Antenna 0

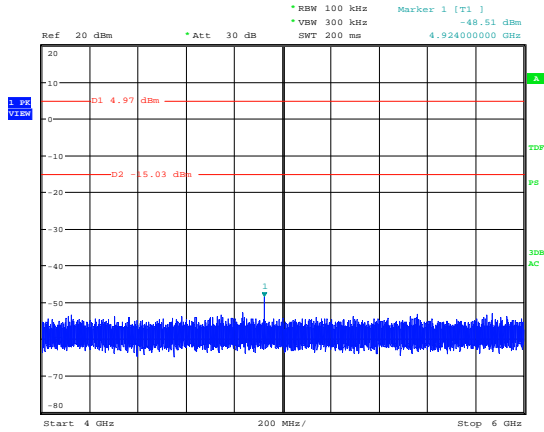

Conducted spurious emissions, mode 11b, 2462MHz
Date: 2.NOV.2015 19:20:28

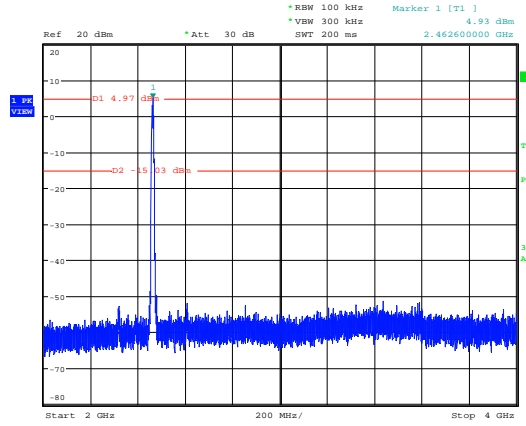

Conducted spurious emissions, mode 11b, 2462MHz
Date: 2.NOV.2015 19:20:09

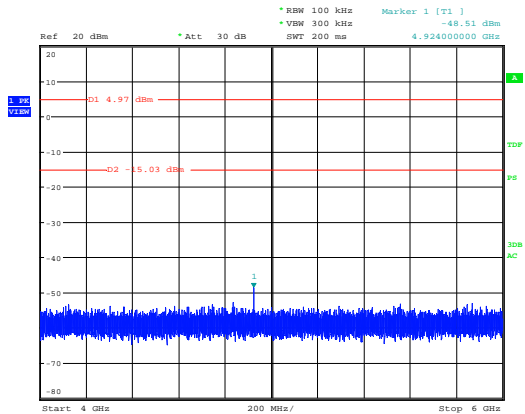

Conducted spurious emissions, mode 11b, 2462MHz
Date: 2.NOV.2015 19:20:28

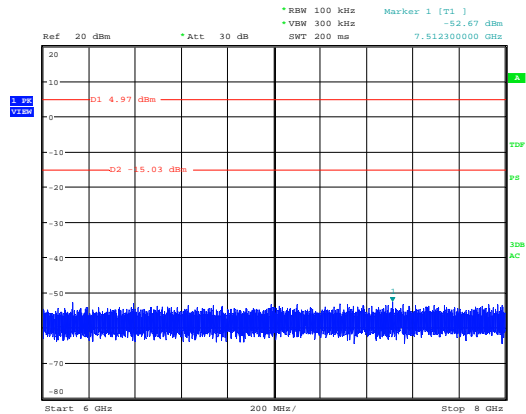

Conducted spurious emissions, mode 11b, 2462MHz
Date: 2.NOV.2015 19:20:59

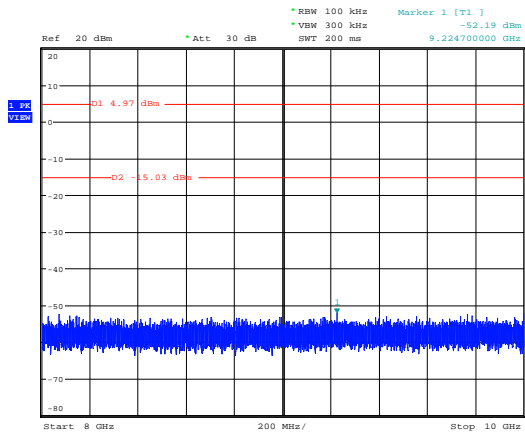

Conducted spurious emissions, mode 11b, 2462MHz
Date: 2.NOV.2015 19:21:45

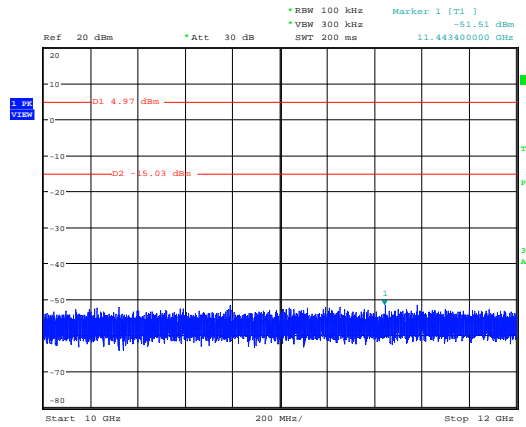

Conducted spurious emissions, mode 11b, 2462MHz
Date: 2.NOV.2015 19:22:23

Prüfbericht - Nr.: 50027424 001
Test Report No.:

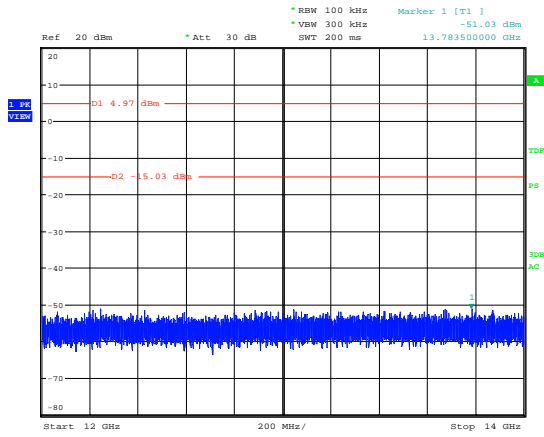

Conducted spurious emissions, mode 11b, 2462MHz
Date: 2.NOV.2015 19:22:42

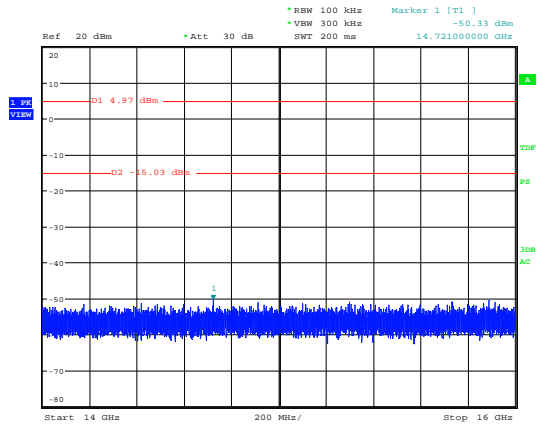

Conducted spurious emissions, mode 11b, 2462MHz
Date: 2.NOV.2015 19:22:56

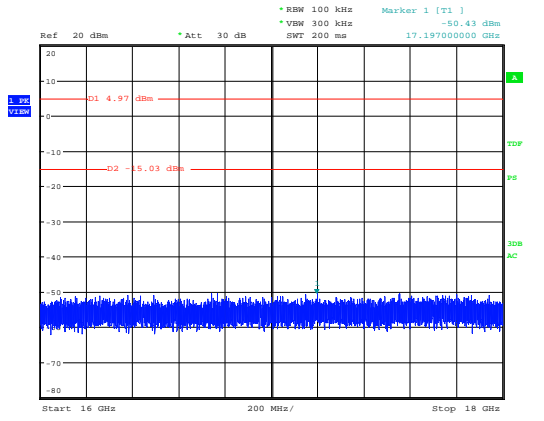

Conducted spurious emissions, mode 11b, 2462MHz
Date: 2.NOV.2015 19:23:35

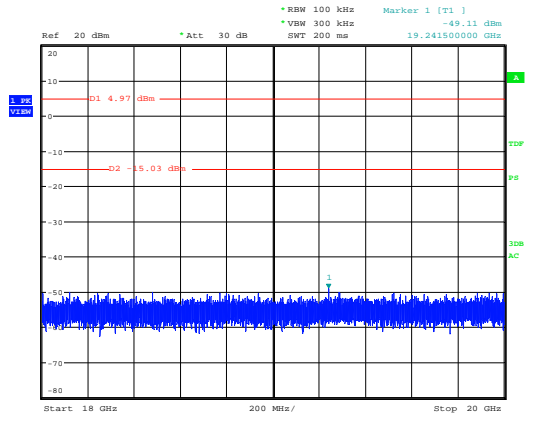

Conducted spurious emissions, mode 11b, 2462MHz
Date: 2.NOV.2015 19:24:05

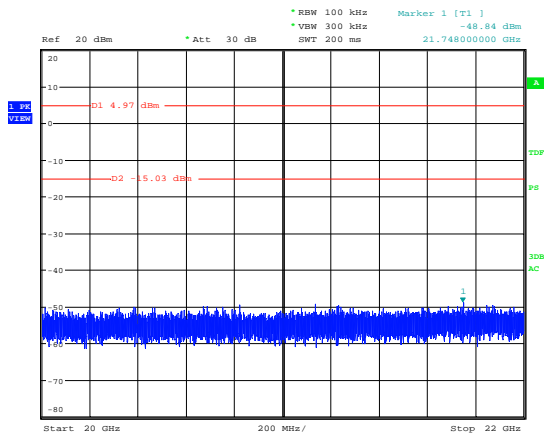

Conducted spurious emissions, mode 11b, 2462MHz
Date: 2.NOV.2015 19:24:39

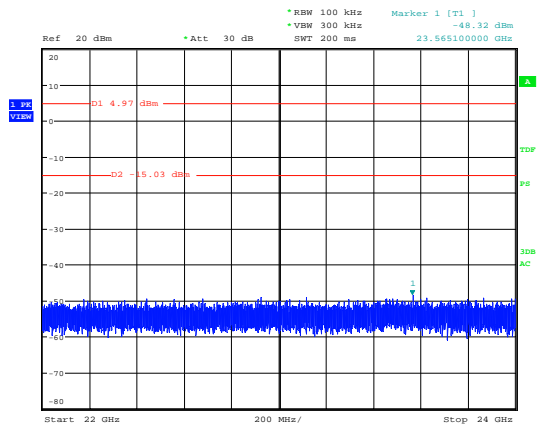

Conducted spurious emissions, mode 11b, 2462MHz
Date: 2.NOV.2015 19:25:02

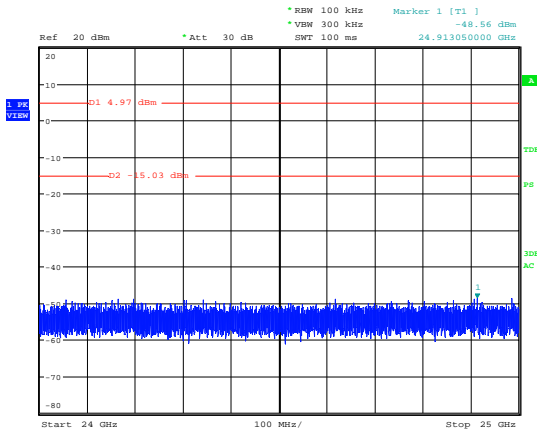

Conducted spurious emissions, mode 11b, 2462MHz
Date: 2.NOV.2015 19:25:30

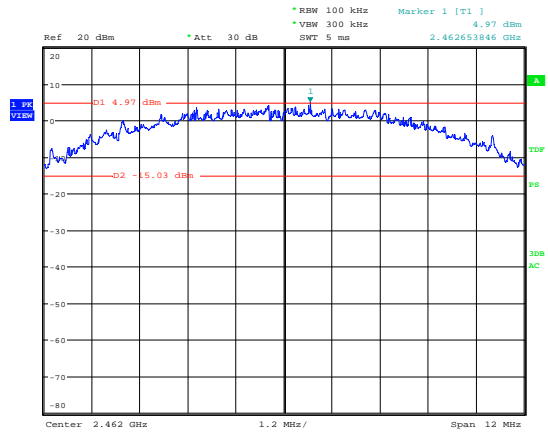

Conducted spurious emissions, mode 11b, 2462MHz
Date: 2.NOV.2015 19:19:11

Figure 41: Conducted Spurious Emissions in Non-Restricted Frequency Bands, 30MHz - 25GHz, Mode A (2412MHz), 11g_Antenna 0

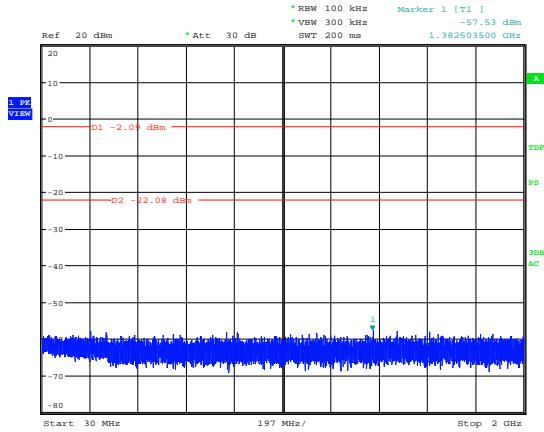

Conducted spurious emissions, mode 11g, 2412MHz
Date: 2.NOV.2015 18:52:34

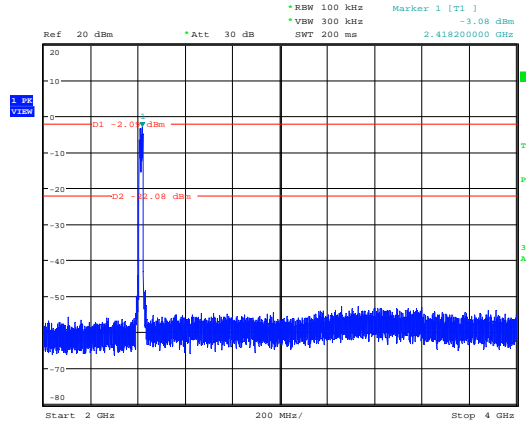

Conducted spurious emissions, mode 11g, 2412MHz
Date: 2.NOV.2015 18:52:50

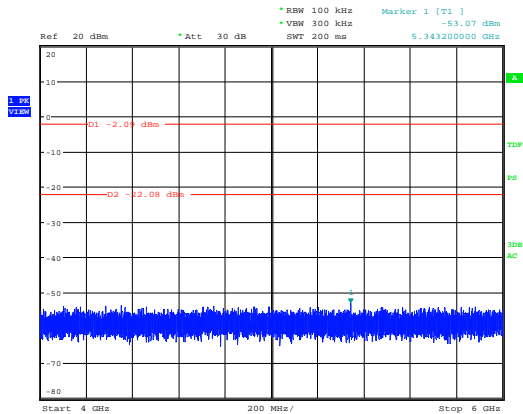

Conducted spurious emissions, mode 11g, 2412MHz
Date: 2.NOV.2015 18:53:03

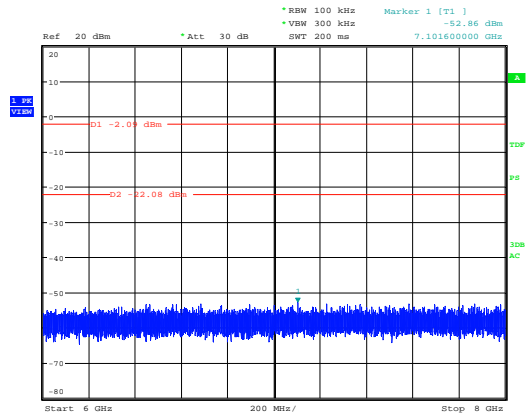

Conducted spurious emissions, mode 11g, 2412MHz
Date: 2.NOV.2015 18:53:18

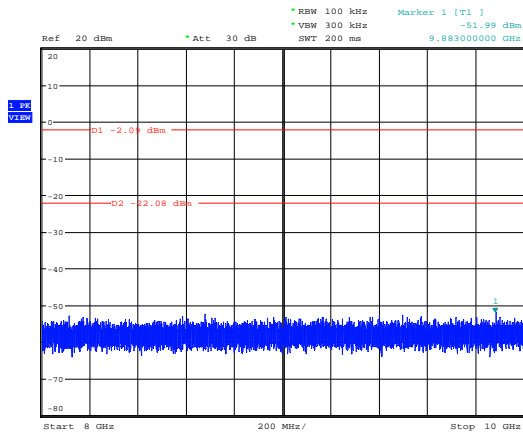

Conducted spurious emissions, mode 11g, 2412MHz
Date: 2.NOV.2015 18:53:33

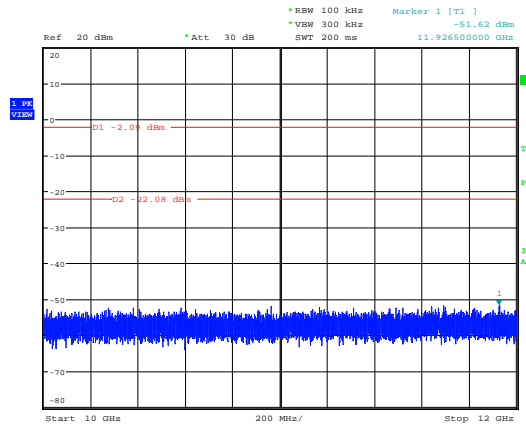

Conducted spurious emissions, mode 11g, 2412MHz
Date: 2.NOV.2015 18:53:49

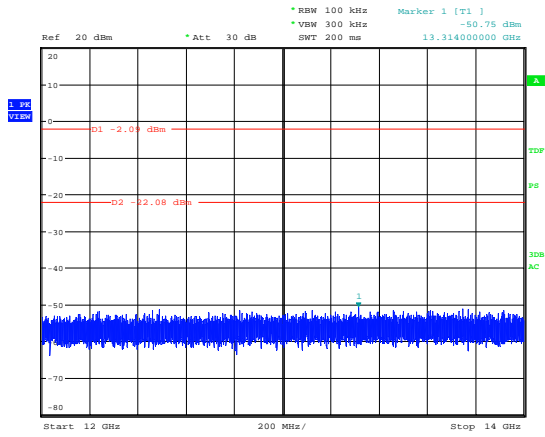

Conducted spurious emissions, mode 11g, 2412MHz
Date: 2.NOV.2015 18:54:04

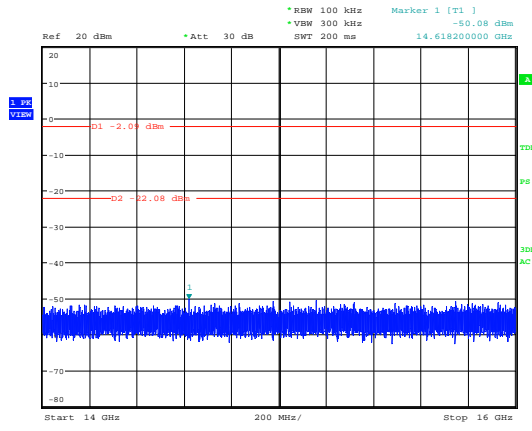

Conducted spurious emissions, mode 11g, 2412MHz
Date: 2.NOV.2015 18:54:34

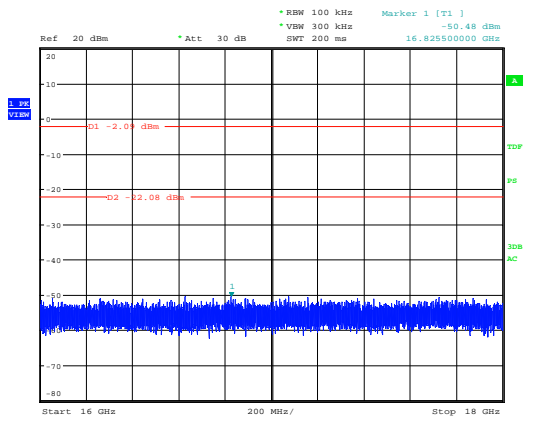

Conducted spurious emissions, mode 11g, 2412MHz
Date: 2.NOV.2015 18:54:53

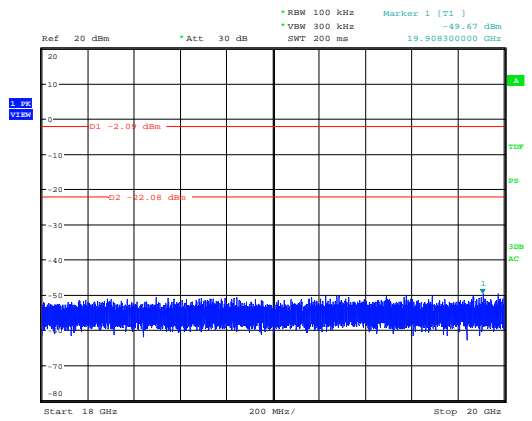

Conducted spurious emissions, mode 11g, 2412MHz
Date: 2.NOV.2015 18:55:15

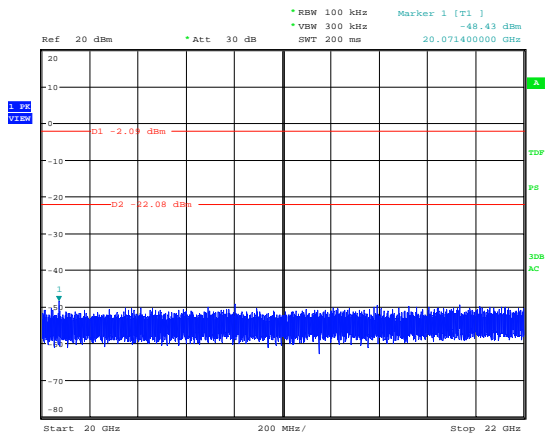

Conducted spurious emissions, mode 11g, 2412MHz
Date: 2.NOV.2015 18:55:36

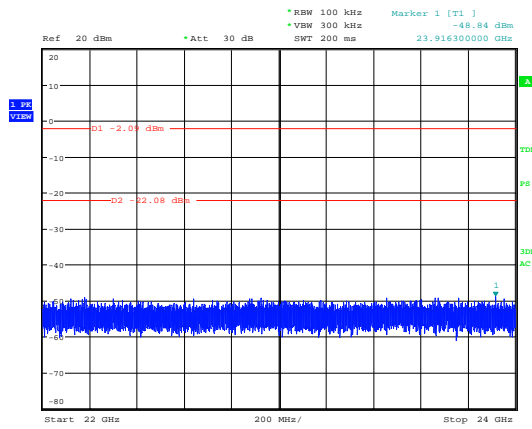

Conducted spurious emissions, mode 11g, 2412MHz
Date: 2.NOV.2015 18:55:50

Produkte
Products

Prüfbericht - Nr.: 50027424 001
Test Report No.:

Seite 57 von 123
Page 57 of 123

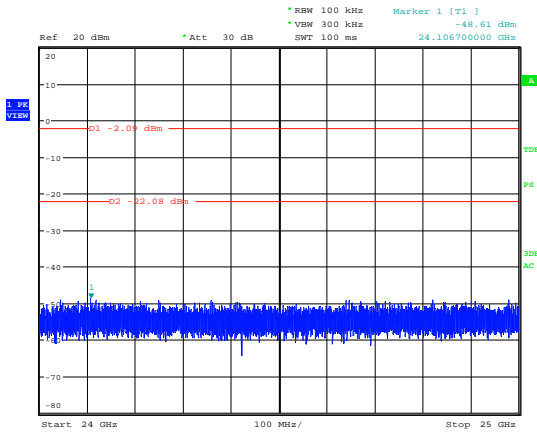

Conducted spurious emissions, mode 1lg, 2412MHz
Date: 2.NOV.2015 18:56:24

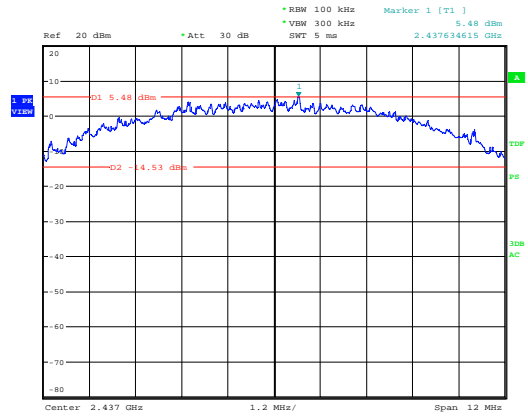

Conducted spurious emissions, mode 1lb, 2437MHz
Date: 2.NOV.2015 19:27:14

Figure 42: Conducted Spurious Emissions in Non-Restricted Frequency Bands, 30MHz - 25GHz, Mode B (2437MHz), 11g_Antenna 0

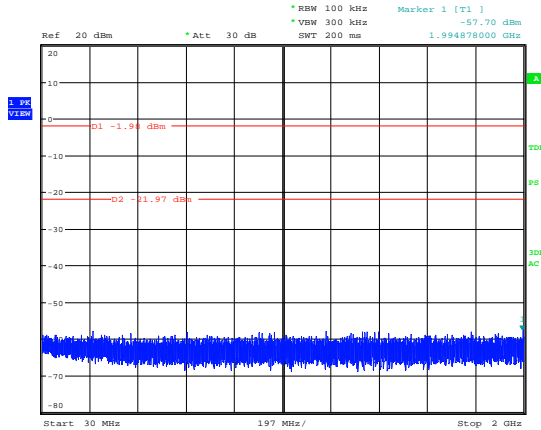

Conducted spurious emissions, mode 11g, 2437MHz
Date: 2.NOV.2015 18:59:10

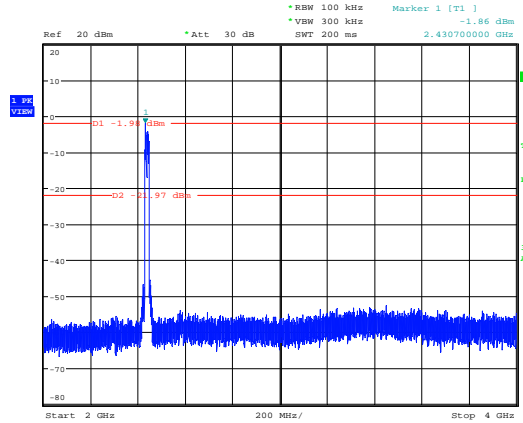

Conducted spurious emissions, mode 11g, 2437MHz
Date: 2.NOV.2015 18:59:42

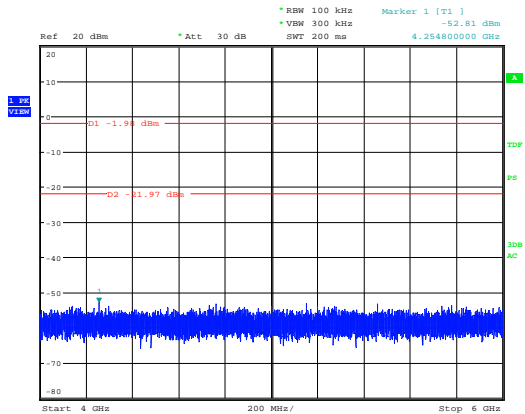

Conducted spurious emissions, mode 11g, 2437MHz
Date: 2.NOV.2015 19:00:10

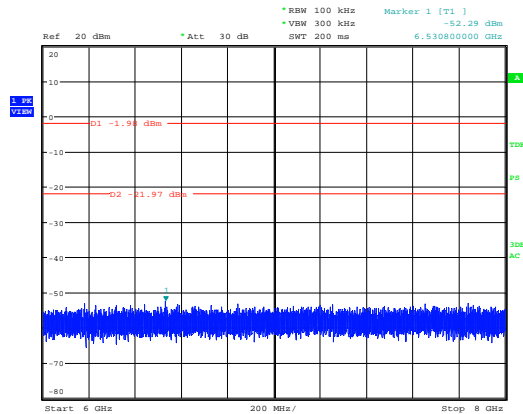

Conducted spurious emissions, mode 11g, 2437MHz
Date: 2.NOV.2015 19:00:37

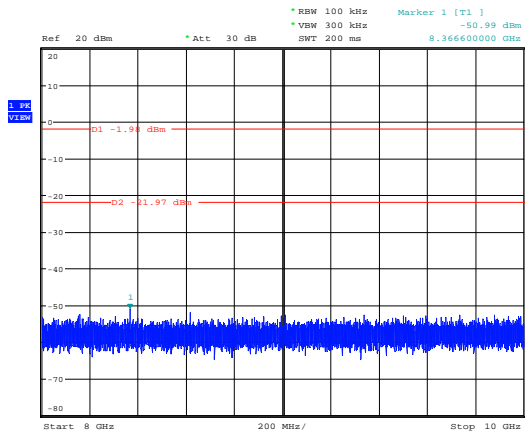

Conducted spurious emissions, mode 11g, 2437MHz
Date: 2.NOV.2015 19:00:57

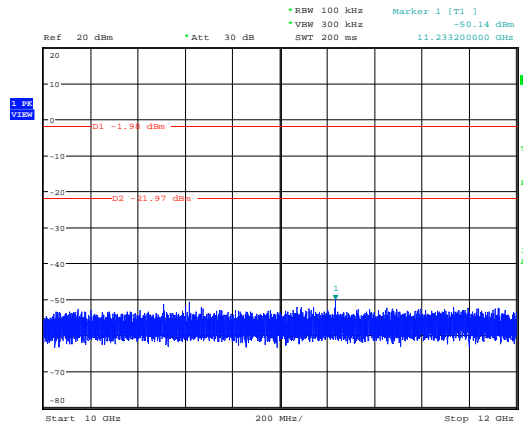

Conducted spurious emissions, mode 11g, 2437MHz
Date: 2.NOV.2015 19:01:13

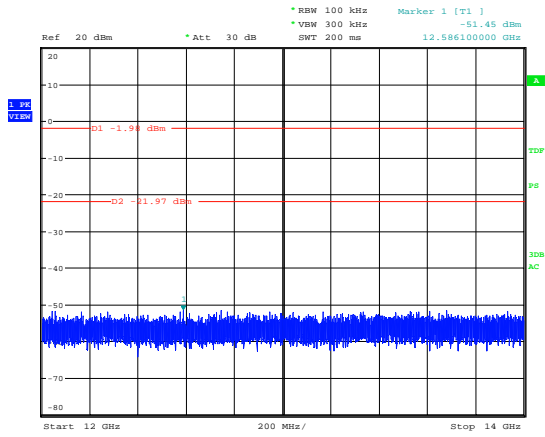

Conducted spurious emissions, mode 11g, 2437MHz
Date: 2.NOV.2015 19:01:27

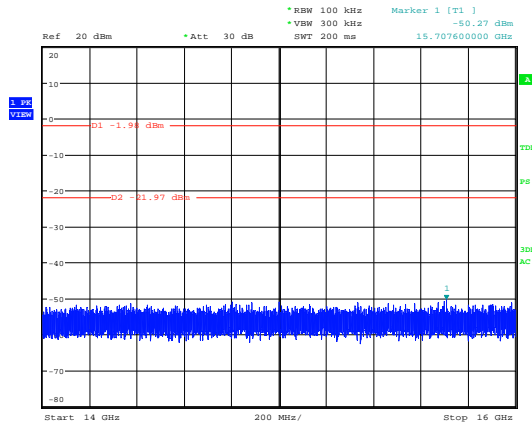

Conducted spurious emissions, mode 11g, 2437MHz
Date: 2.NOV.2015 19:01:40

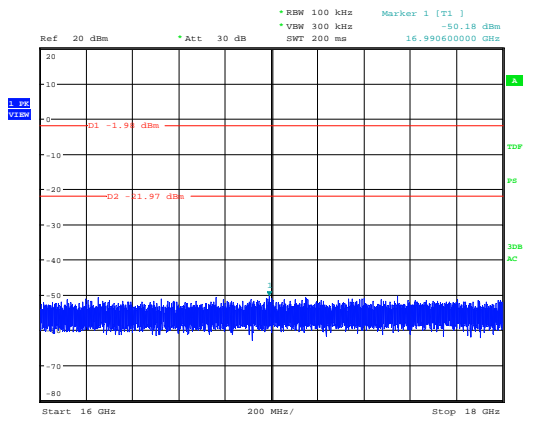

Conducted spurious emissions, mode 11g, 2437MHz
Date: 2.NOV.2015 19:01:56

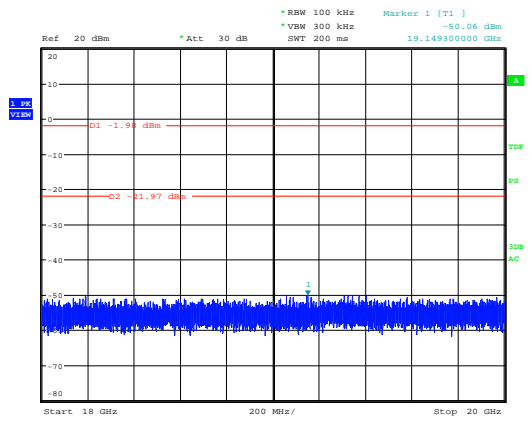

Conducted spurious emissions, mode 11g, 2437MHz
Date: 2.NOV.2015 19:02:13

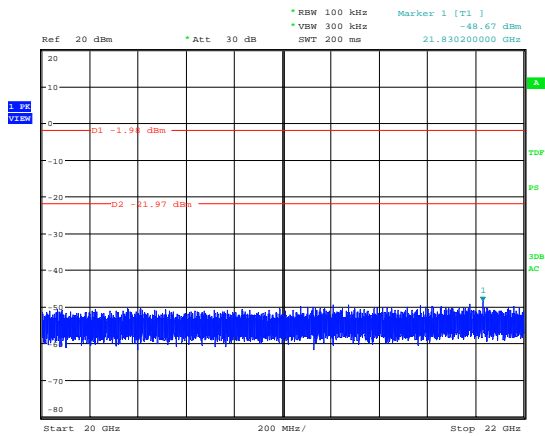

Conducted spurious emissions, mode 11g, 2437MHz
Date: 2.NOV.2015 19:02:37

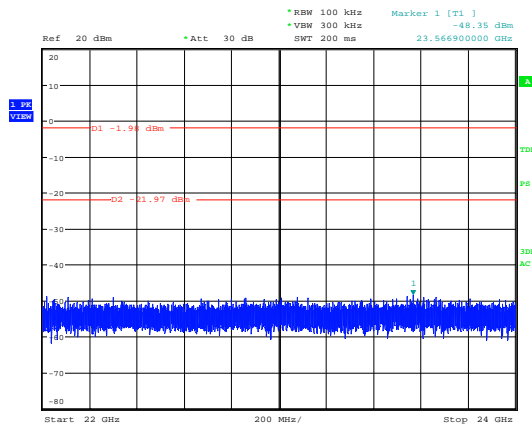

Conducted spurious emissions, mode 11g, 2437MHz
Date: 2.NOV.2015 19:02:55

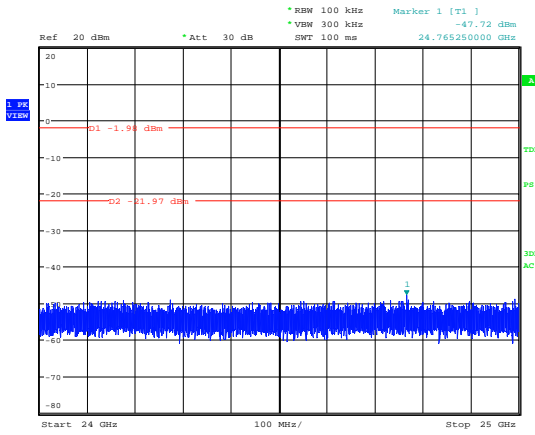

Conducted spurious emissions, mode 1lg, 2437MHz
Date: 2.NOV.2015 19:03:13

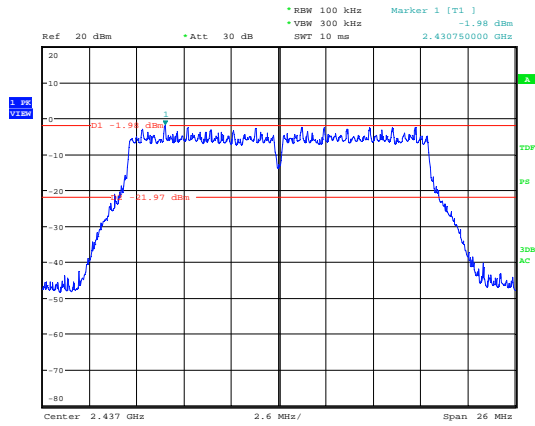

Conducted spurious emissions, mode 1lg, 2437MHz
Date: 2.NOV.2015 18:58:48

Figure 43: Conducted Spurious Emissions in Non-Restricted Frequency Bands, 30MHz - 25GHz, Mode C (2462MHz), 11g_Antenna 0

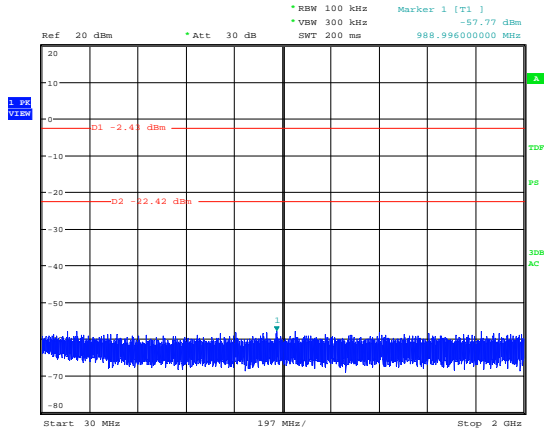

Conducted spurious emissions, mode 11g, 2462MHz
Date: 2.NOV.2015 19:04:37

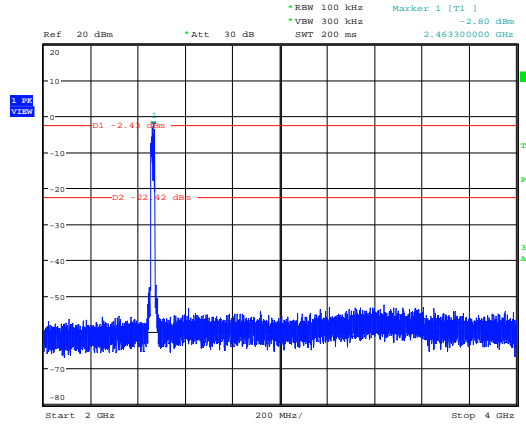

Conducted spurious emissions, mode 11g, 2462MHz
Date: 2.NOV.2015 19:04:57

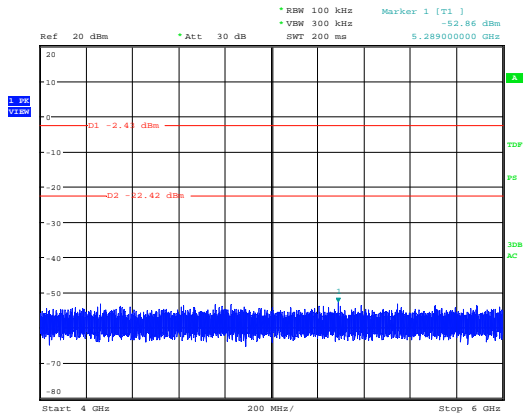

Conducted spurious emissions, mode 11g, 2462MHz
Date: 2.NOV.2015 19:05:10

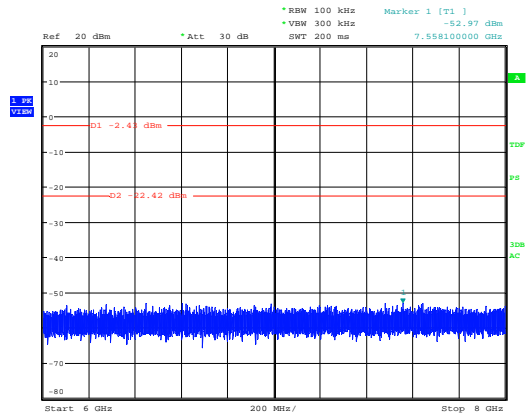

Conducted spurious emissions, mode 11g, 2462MHz
Date: 2.NOV.2015 19:05:34

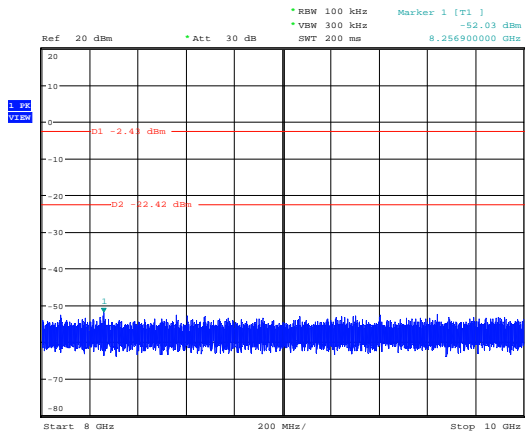

Conducted spurious emissions, mode 11g, 2462MHz
Date: 2.NOV.2015 19:05:51

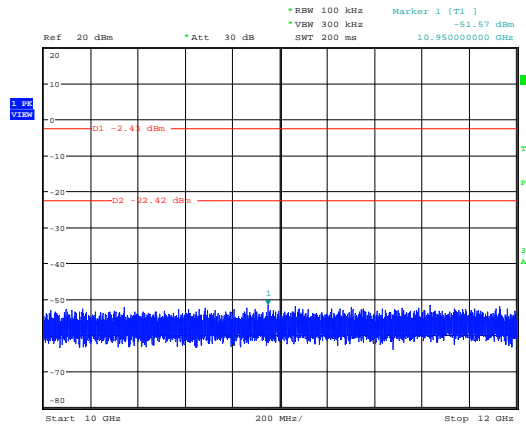

Conducted spurious emissions, mode 11g, 2462MHz
Date: 2.NOV.2015 19:06:05

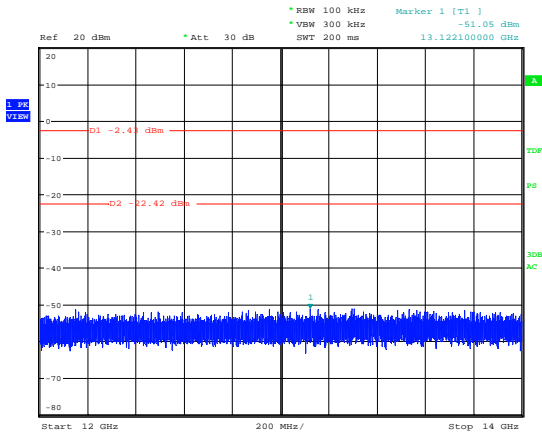

Conducted spurious emissions, mode 11g, 2462MHz
Date: 2.NOV.2015 19:06:19

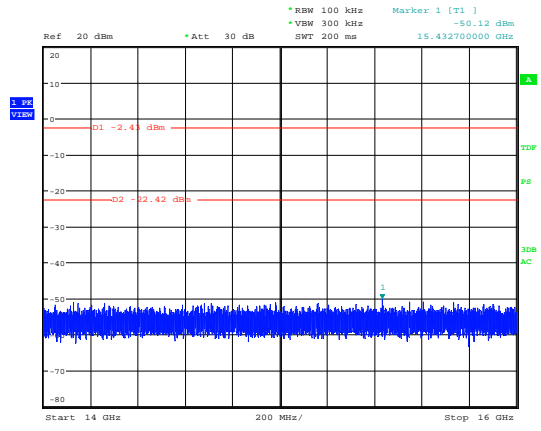

Conducted spurious emissions, mode 11g, 2462MHz
Date: 2.NOV.2015 19:06:36

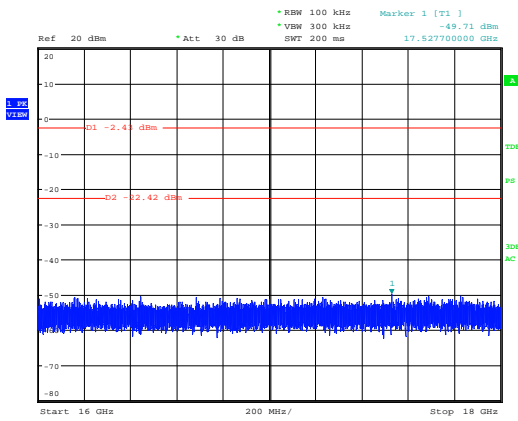

Conducted spurious emissions, mode 11g, 2462MHz
Date: 2.NOV.2015 19:06:55

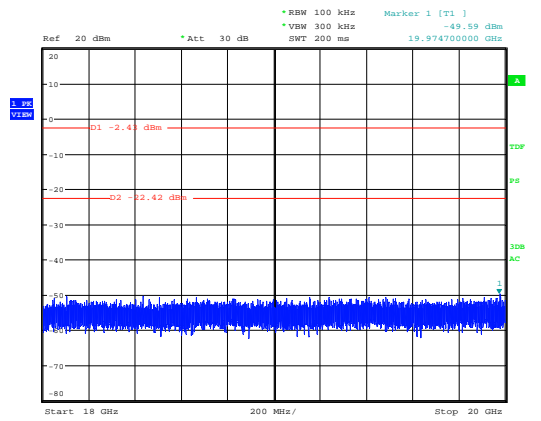

Conducted spurious emissions, mode 11g, 2462MHz
Date: 2.NOV.2015 19:07:15

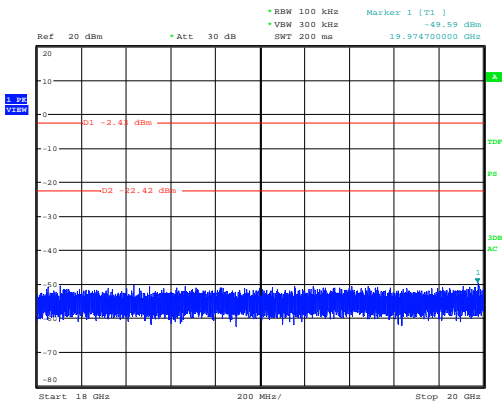

Conducted spurious emissions, mode 11g, 2462MHz
Date: 2.NOV.2015 19:07:15

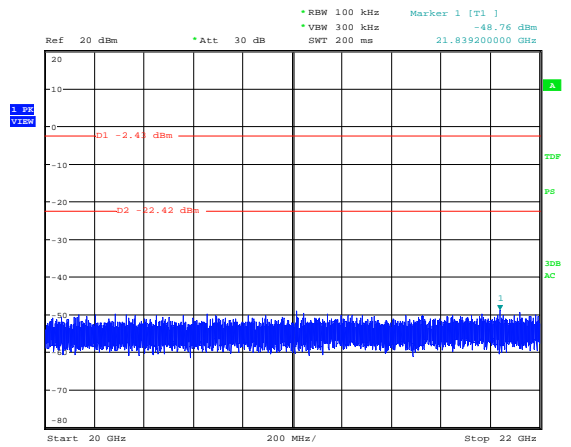

Conducted spurious emissions, mode 11g, 2462MHz
Date: 2.NOV.2015 19:07:42

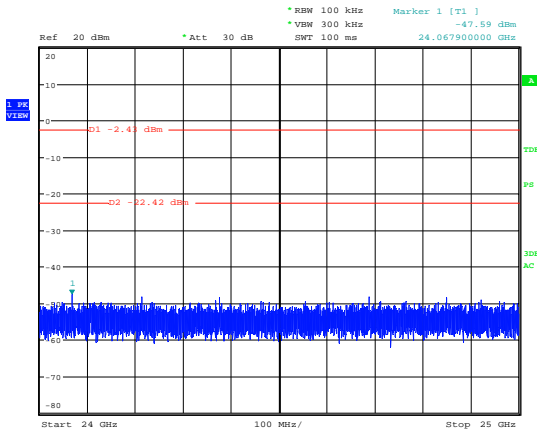

Conducted spurious emissions, mode 1lg, 2462MHz
Date: 2.NOV.2015 19:08:34

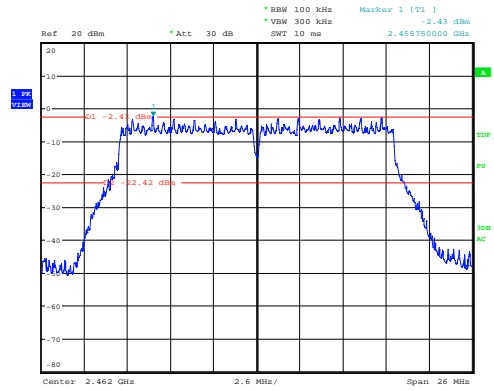

Conducted spurious emissions, mode 1lg, 2462MHz
Date: 2.NOV.2015 19:04:18

Figure 44: Conducted Spurious Emissions in Non-Restricted Frequency Bands, 30MHz - 25GHz, Mode A (2412MHz), 11n(20HT)_Antenna 0

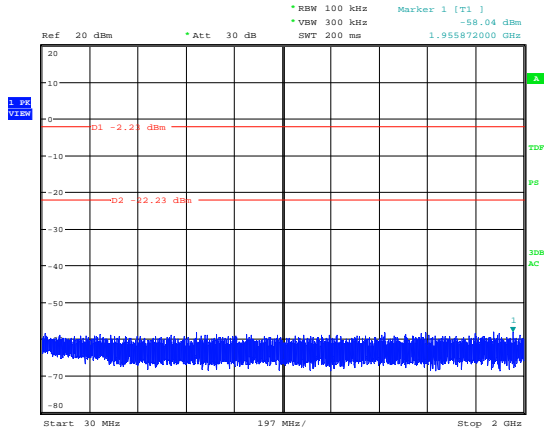

Conducted spurious emissions, mode 11n(20HT), 2412MHz
Date: 2.NOV.2015 18:46:19

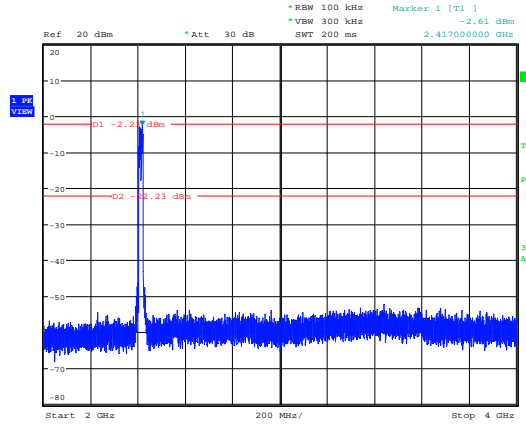

Conducted spurious emissions, mode 11n(20HT), 2412MHz
Date: 2.NOV.2015 18:46:35

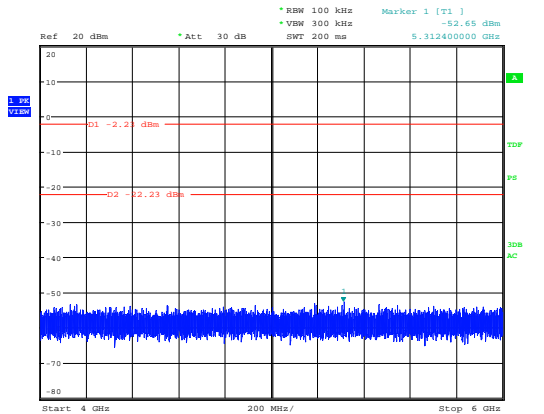

Conducted spurious emissions, mode 11n(20HT), 2412MHz
Date: 2.NOV.2015 18:46:50

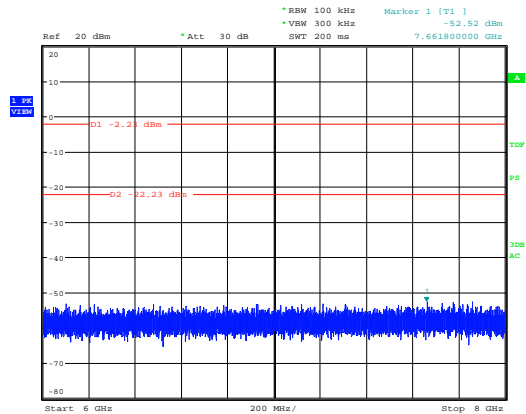

Conducted spurious emissions, mode 11n(20HT), 2412MHz
Date: 2.NOV.2015 18:47:09

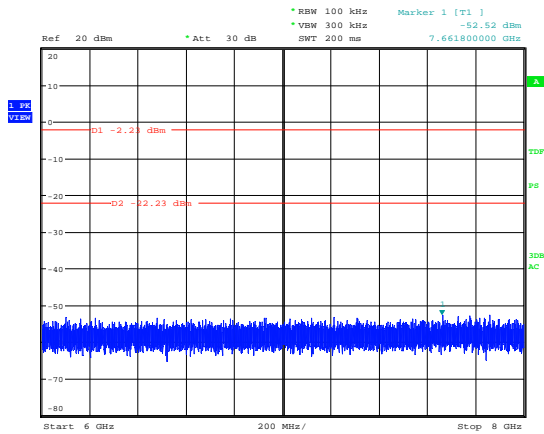

Conducted spurious emissions, mode 11n(20HT), 2412MHz
Date: 2.NOV.2015 18:47:09

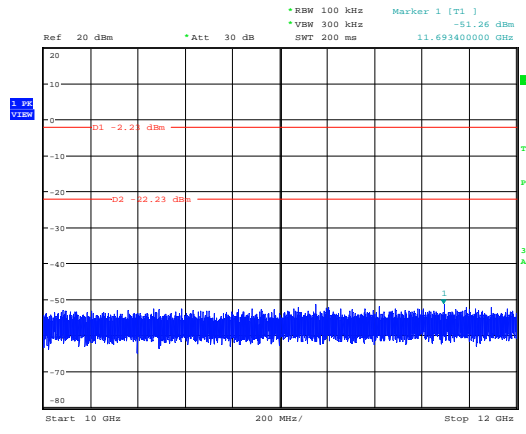

Conducted spurious emissions, mode 11n(20HT), 2412MHz
Date: 2.NOV.2015 18:47:45

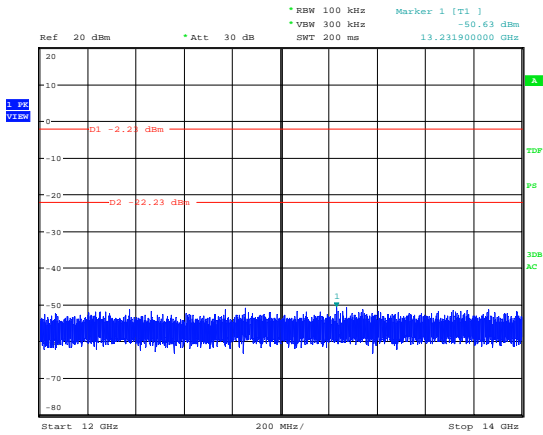

Conducted spurious emissions, mode 11n(20HT), 2412MHz
Date: 2.NOV.2015 18:48:04

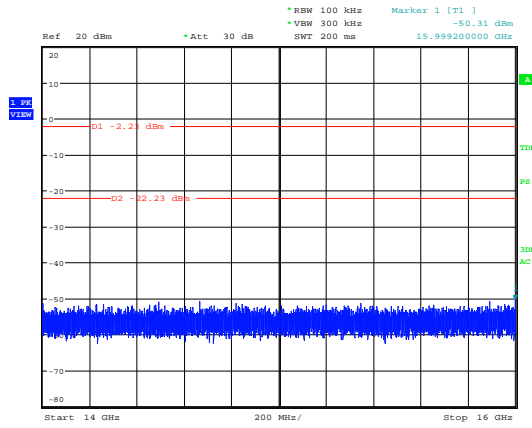

Conducted spurious emissions, mode 11n(20HT), 2412MHz
Date: 2.NOV.2015 18:48:19

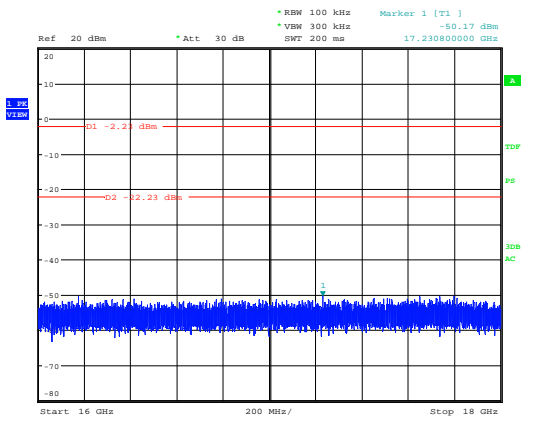

Conducted spurious emissions, mode 11n(20HT), 2412MHz
Date: 2.NOV.2015 18:48:39

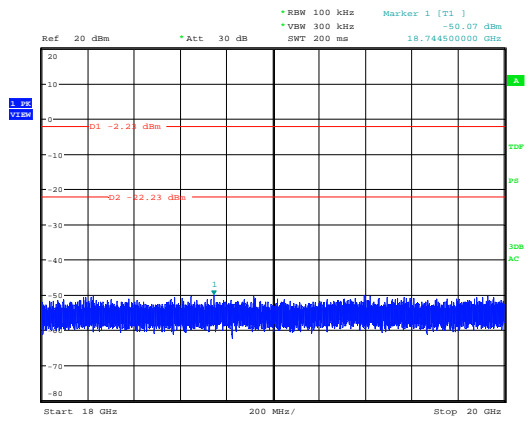

Conducted spurious emissions, mode 11n(20HT), 2412MHz
Date: 2.NOV.2015 18:49:04

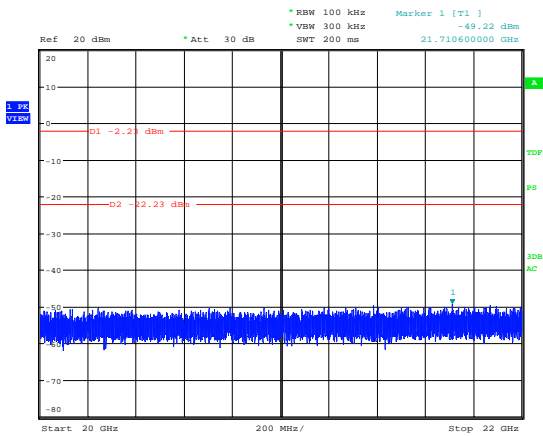

Conducted spurious emissions, mode 11n(20HT), 2412MHz
Date: 2.NOV.2015 18:49:17

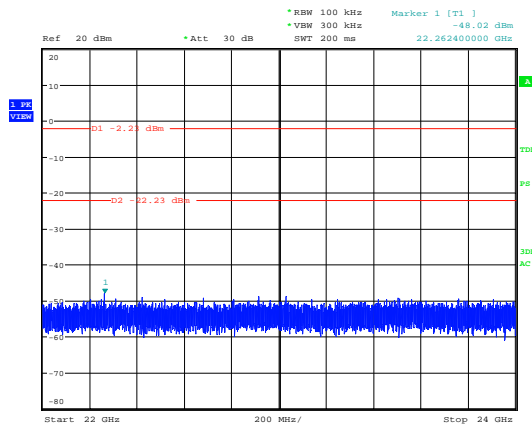

Conducted spurious emissions, mode 11n(20HT), 2412MHz
Date: 2.NOV.2015 18:49:37

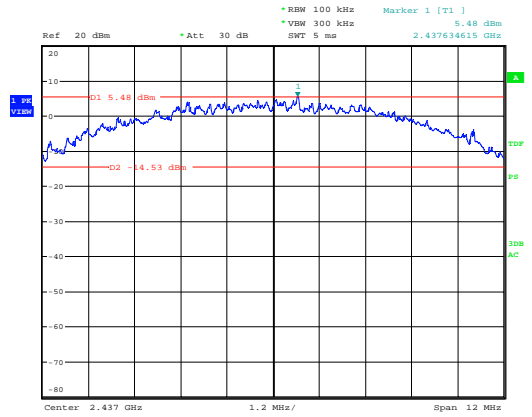
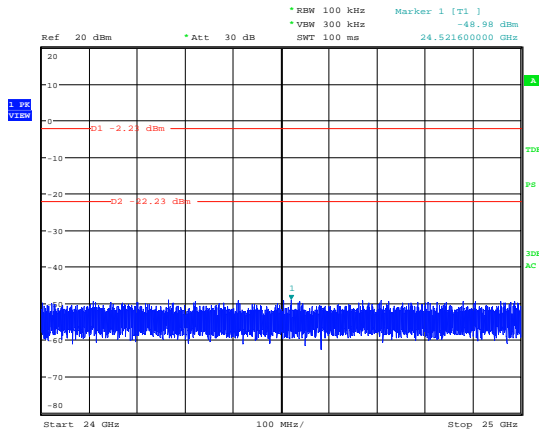

Conducted spurious emissions, mode 11n(20HT), 2412MHz
Date: 2.NOV.2015 18:49:59

Conducted spurious emissions, mode 11b, 2437MHz
Date: 2.NOV.2015 19:27:14

Figure 45: Conducted Spurious Emissions in Non-Restricted Frequency Bands, 30MHz - 25GHz, Mode B (2462MHz), 11n(20HT)_Antenna 0

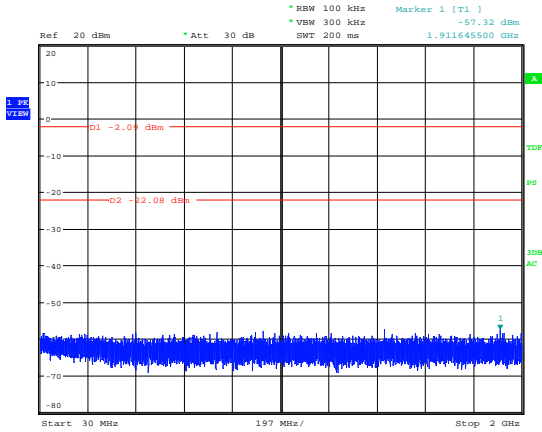

Conducted spurious emissions, mode 11n(20HT), 2437MHz
Date: 2.NOV.2015 18:41:32

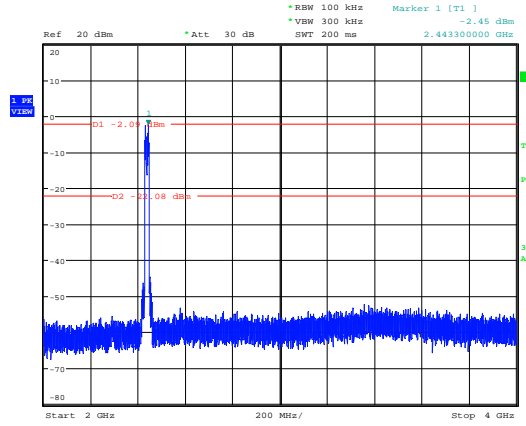

Conducted spurious emissions, mode 11n(20HT), 2437MHz
Date: 2.NOV.2015 18:41:45

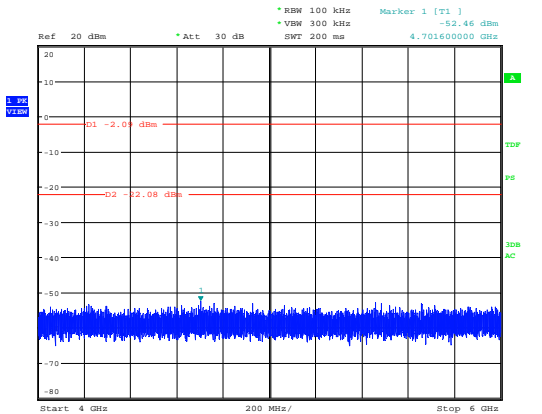

Conducted spurious emissions, mode 11n(20HT), 2437MHz
Date: 2.NOV.2015 18:41:59

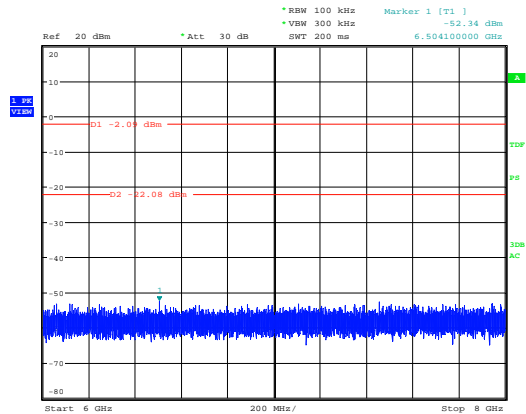

Conducted spurious emissions, mode 11n(20HT), 2437MHz
Date: 2.NOV.2015 18:42:14

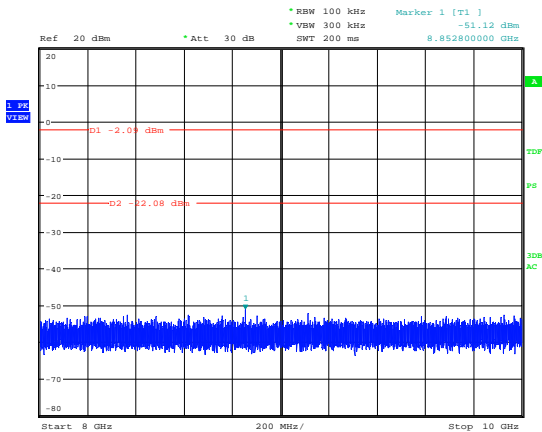

Conducted spurious emissions, mode 11n(20HT), 2437MHz
Date: 2.NOV.2015 18:42:29

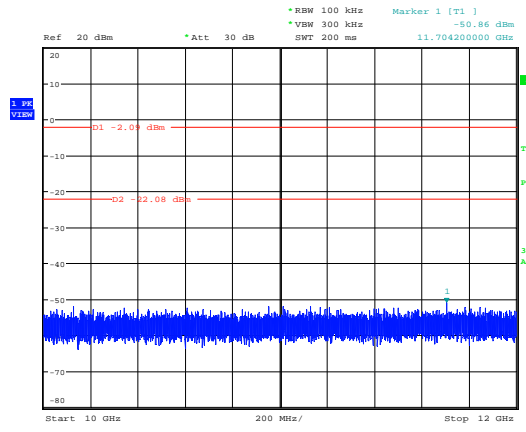

Conducted spurious emissions, mode 11n(20HT), 2437MHz
Date: 2.NOV.2015 18:42:46

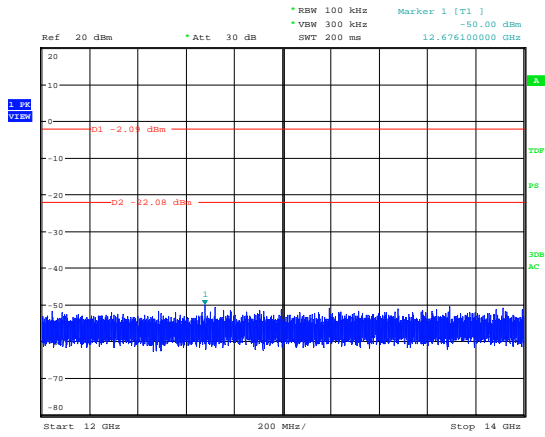

Conducted spurious emissions, mode 11n(20HT), 2437MHz
Date: 2.NOV.2015 18:43:06

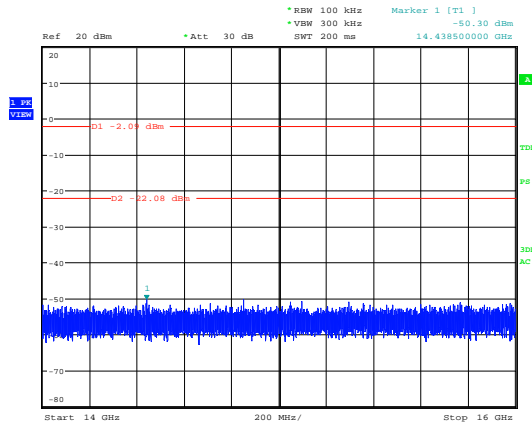

Conducted spurious emissions, mode 11n(20HT), 2437MHz
Date: 2.NOV.2015 18:43:23

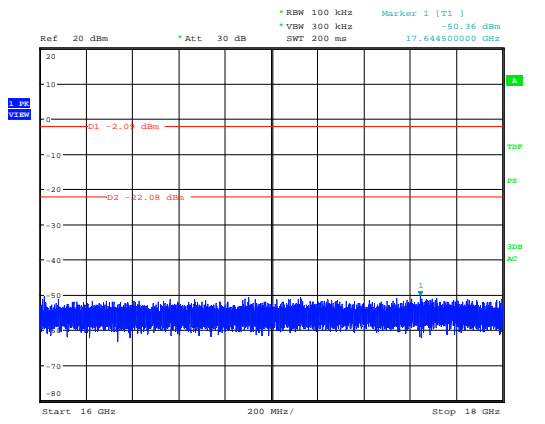

Conducted spurious emissions, mode 11n(20HT), 2437MHz
Date: 2.NOV.2015 18:43:39

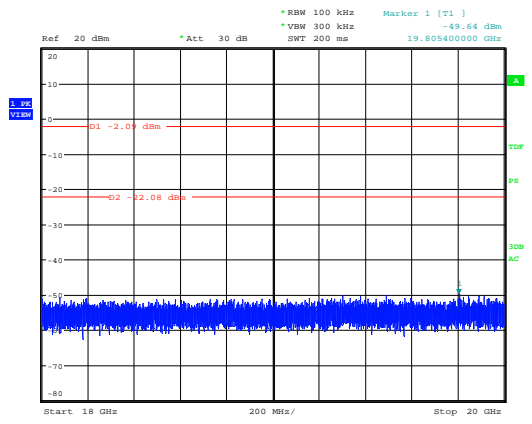

Conducted spurious emissions, mode 11n(20HT), 2437MHz
Date: 2.NOV.2015 18:43:55

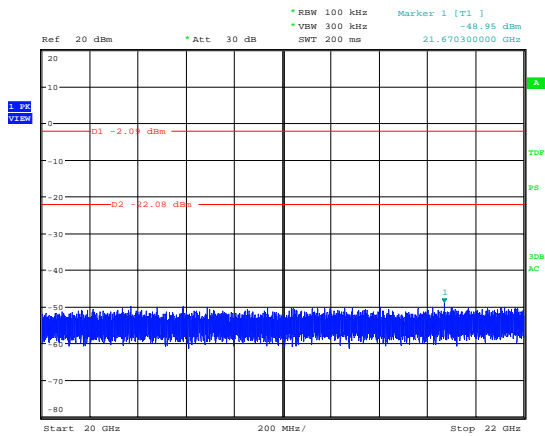

Conducted spurious emissions, mode 11n(20HT), 2437MHz
Date: 2.NOV.2015 18:44:10

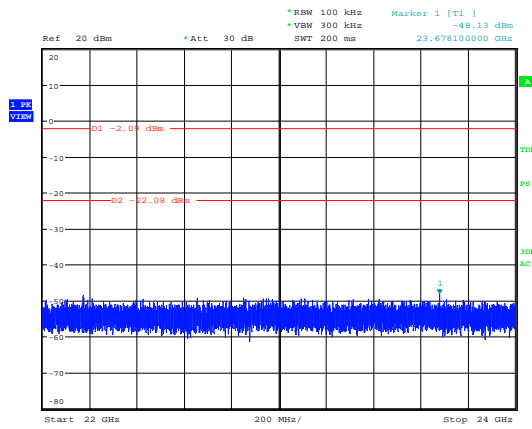

Conducted spurious emissions, mode 11n(20HT), 2437MHz
Date: 2.NOV.2015 18:44:25

Produkte
Products

Prüfbericht - Nr.: **50027424 001**
Test Report No.:

Seite 69 von 123
Page 69 of 123

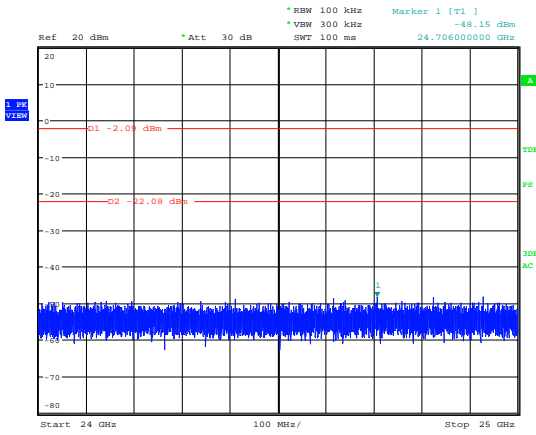

Conducted spurious emissions, mode 11n(20HT), 2437MHz
Date: 2.NOV.2015 18:44:40

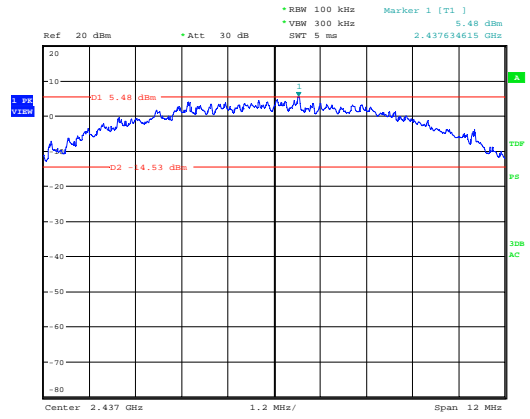

Conducted spurious emissions, mode 11b, 2437MHz
Date: 2.NOV.2015 19:27:14

Figure 46: Conducted Spurious Emissions in Non-Restricted Frequency Bands, 30MHz - 25GHz, Mode C (2462MHz), 11n(20HT)_Antenna 0

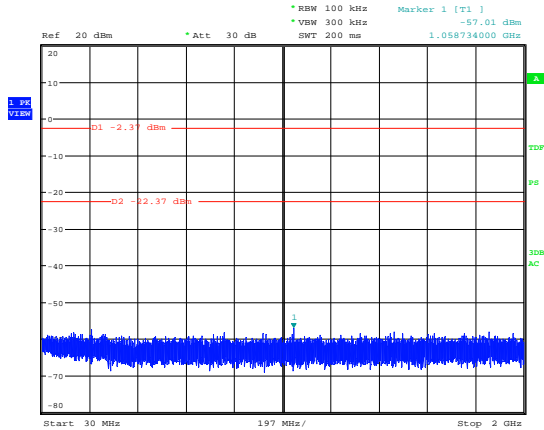

Conducted spurious emissions, mode 11n(20HT), 2462MHz
Date: 2.NOV.2015 18:35:10

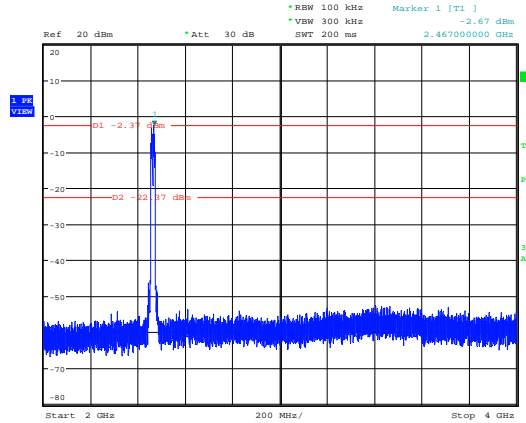

Conducted spurious emissions, mode 11n(20HT), 2462MHz
Date: 2.NOV.2015 18:35:24

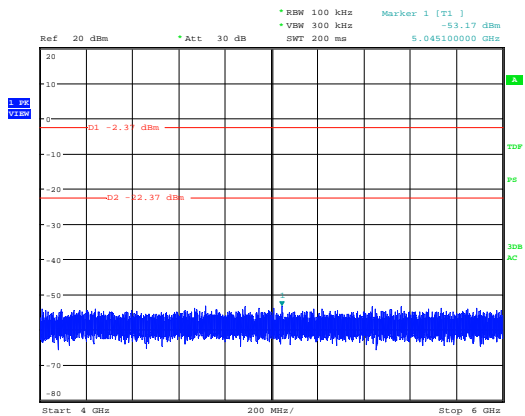

Conducted spurious emissions, mode 11n(20HT), 2462MHz
Date: 2.NOV.2015 18:35:35

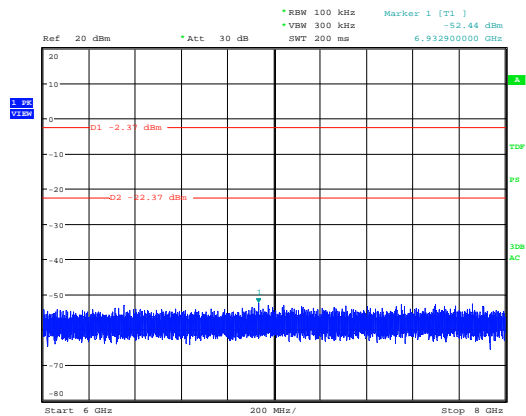

Conducted spurious emissions, mode 11n(20HT), 2462MHz
Date: 2.NOV.2015 18:35:48

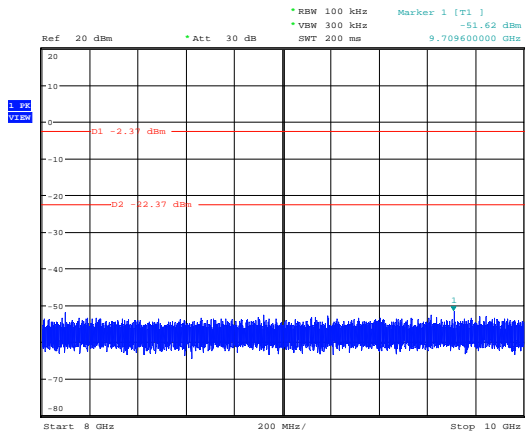

Conducted spurious emissions, mode 11n(20HT), 2462MHz
Date: 2.NOV.2015 18:36:01

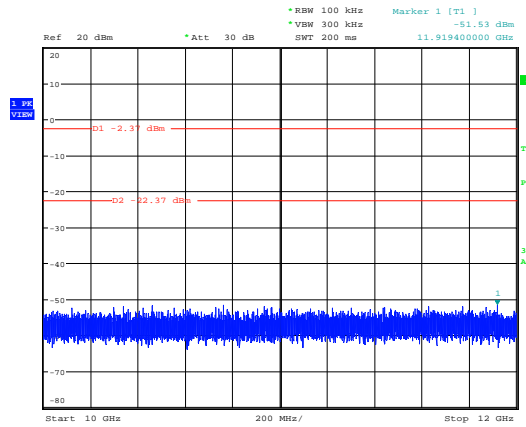

Conducted spurious emissions, mode 11n(20HT), 2462MHz
Date: 2.NOV.2015 18:36:13

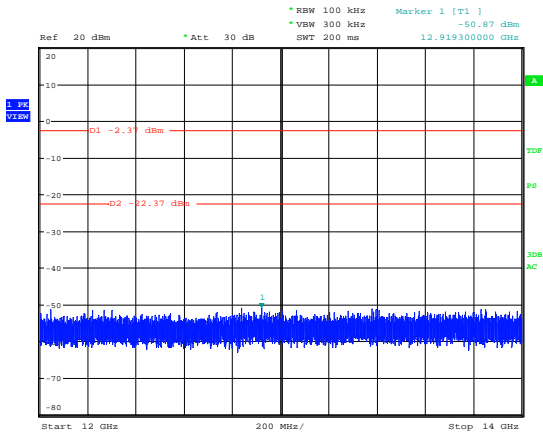

Conducted spurious emissions, mode 11n(20HT), 2462MHz
Date: 2.NOV.2015 18:36:29

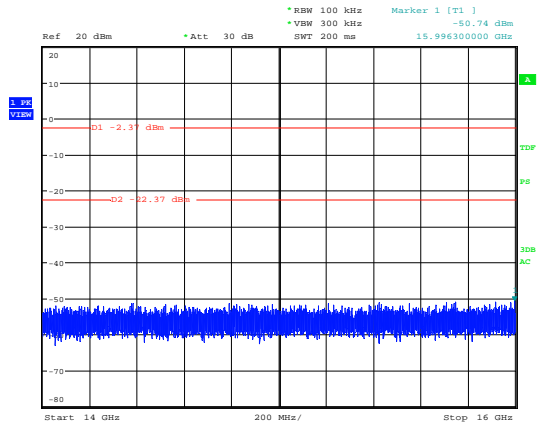

Conducted spurious emissions, mode 11n(20HT), 2462MHz
Date: 2.NOV.2015 18:36:40

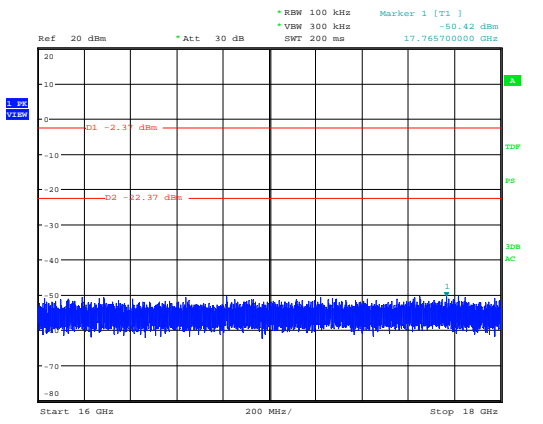

Conducted spurious emissions, mode 11n(20HT), 2462MHz
Date: 2.NOV.2015 18:36:53

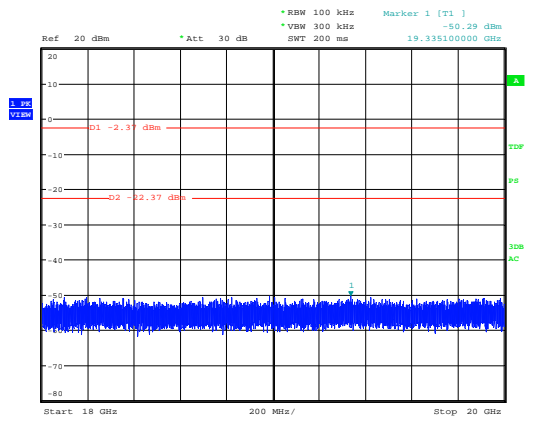

Conducted spurious emissions, mode 11n(20HT), 2462MHz
Date: 2.NOV.2015 18:37:08

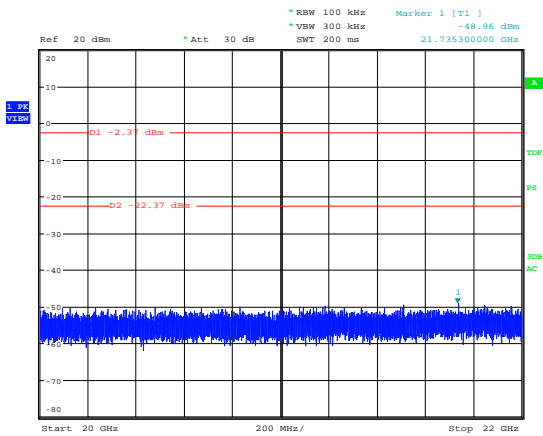

Conducted spurious emissions, mode 11n(20HT), 2462MHz
Date: 2.NOV.2015 18:37:21

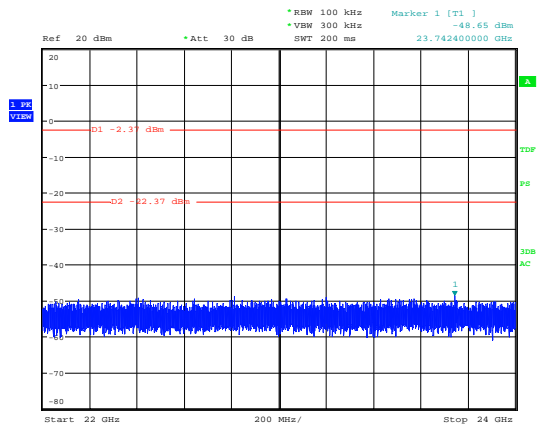

Conducted spurious emissions, mode 11n(20HT), 2462MHz
Date: 2.NOV.2015 18:37:35

Produkte
Products

Prüfbericht - Nr.: 50027424 001
Test Report No.:

Seite 72 von 123
Page 72 of 123

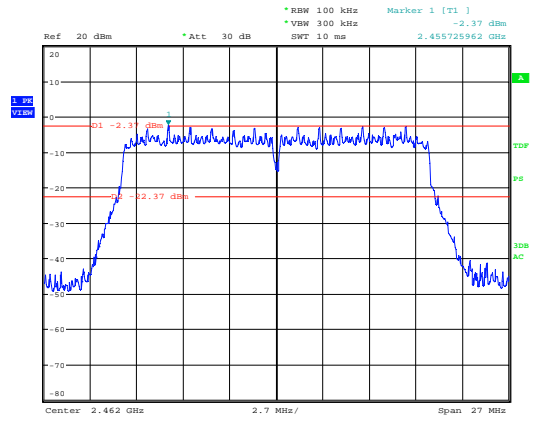
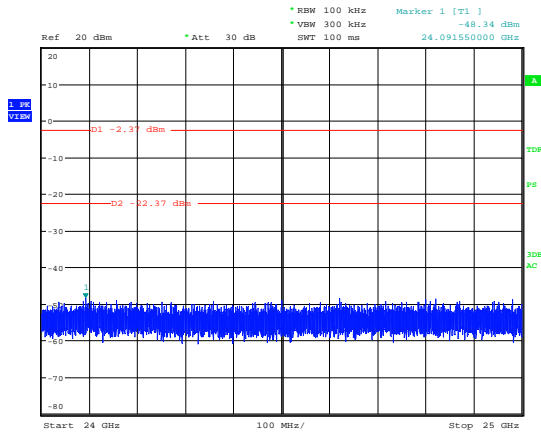

Conducted spurious emissions, mode 11n(20HT), 2462MHz
Date: 2.NOV.2015 18:37:49

Conducted spurious emissions, mode 11n(20HT), 2462MHz
Date: 2.NOV.2015 18:34:58

Figure 47: Conducted Spurious Emissions in Non-Restricted Frequency Bands, 30MHz - 25GHz, Mode A (2422MHz), 11n(40HT)_Antenna 0

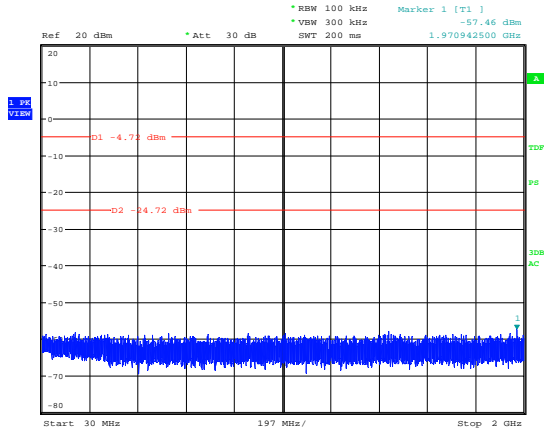

Conducted spurious emissions, mode 11n(40HT), 2422MHz
Date: 2.NOV.2015 20:14:27

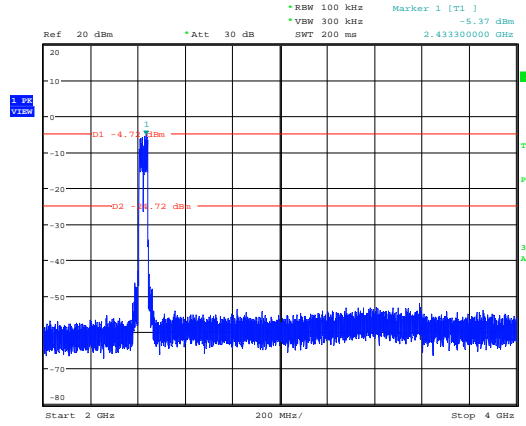

Conducted spurious emissions, mode 11n(40HT), 2422MHz
Date: 2.NOV.2015 20:14:57

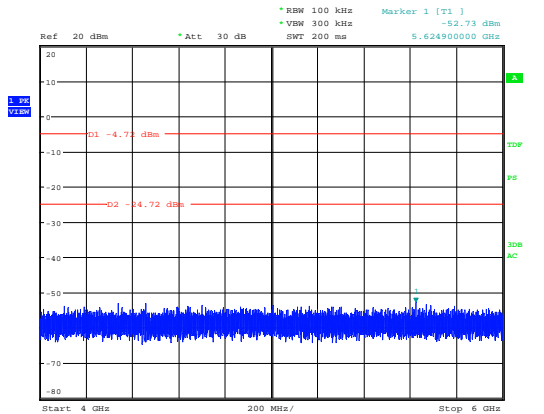

Conducted spurious emissions, mode 11n(40HT), 2422MHz
Date: 2.NOV.2015 20:15:18

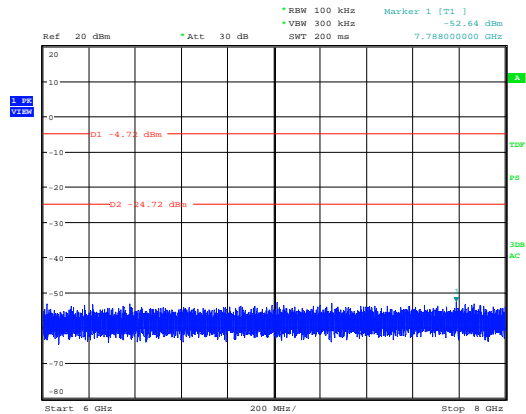

Conducted spurious emissions, mode 11n(40HT), 2422MHz
Date: 2.NOV.2015 20:15:38

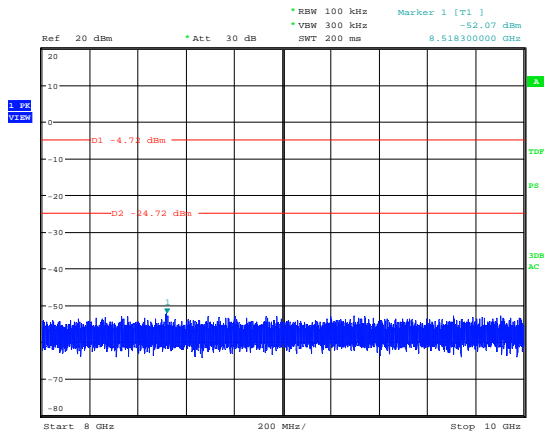

Conducted spurious emissions, mode 11n(40HT), 2422MHz
Date: 2.NOV.2015 20:16:01

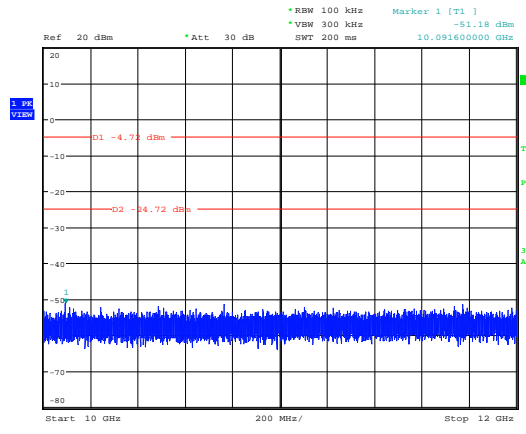

Conducted spurious emissions, mode 11n(40HT), 2422MHz
Date: 2.NOV.2015 20:16:25

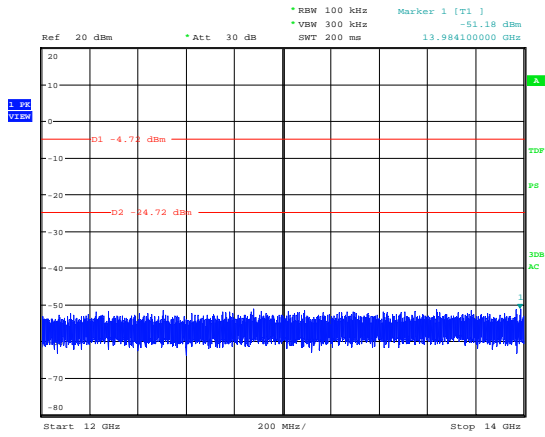

Conducted spurious emissions, mode 11n(40HT), 2422MHz
Date: 2.NOV.2015 20:16:49

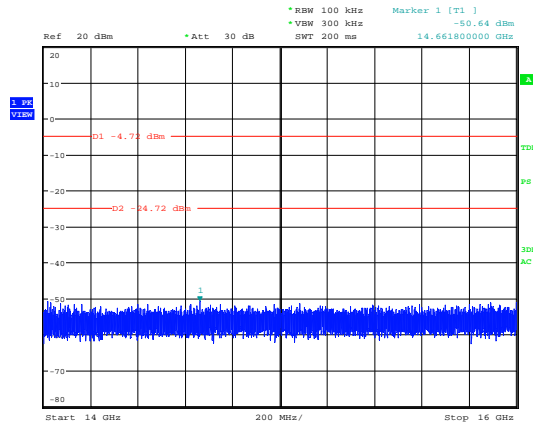

Conducted spurious emissions, mode 11n(40HT), 2422MHz
Date: 2.NOV.2015 20:17:20

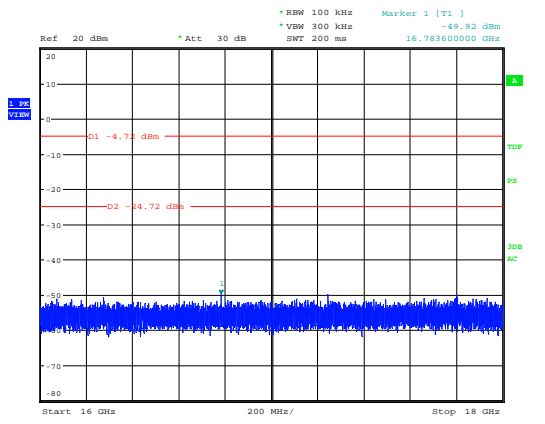

Conducted spurious emissions, mode 11n(40HT), 2422MHz
Date: 2.NOV.2015 20:17:50

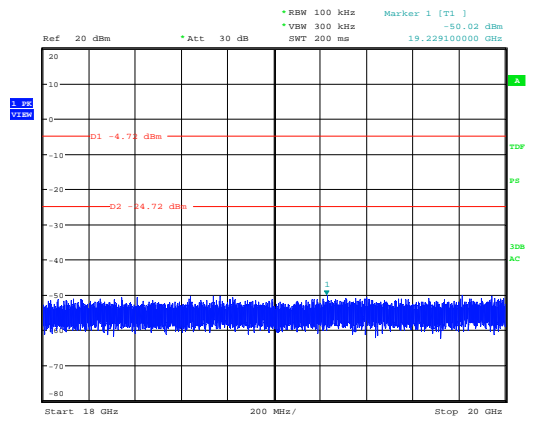

Conducted spurious emissions, mode 11n(40HT), 2422MHz
Date: 2.NOV.2015 20:18:09

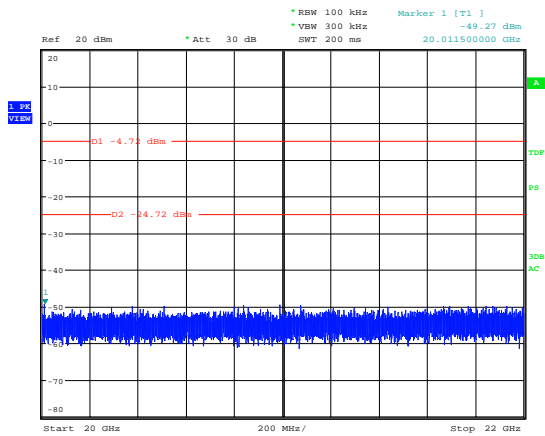

Conducted spurious emissions, mode 11n(40HT), 2422MHz
Date: 2.NOV.2015 20:18:26

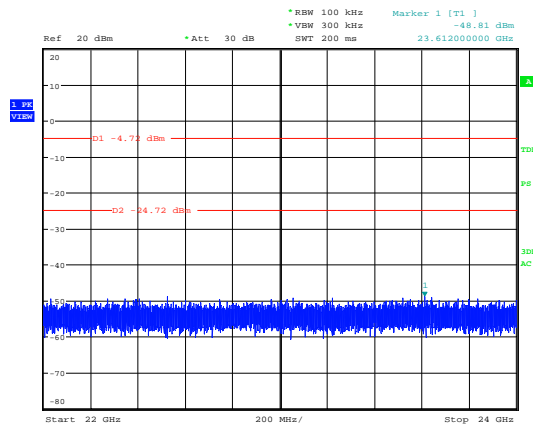

Conducted spurious emissions, mode 11n(40HT), 2422MHz
Date: 2.NOV.2015 20:18:42

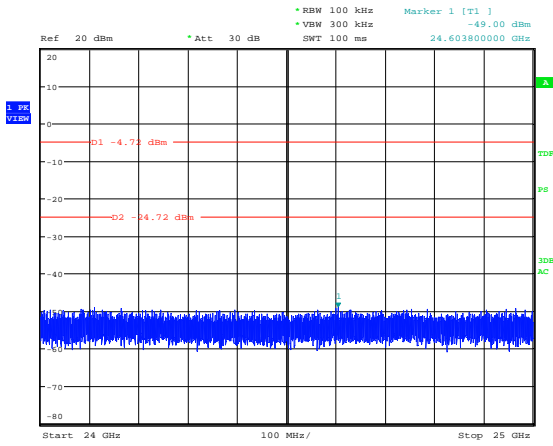

Conducted spurious emissions, mode 11n(40HT), 2422MHz
Date: 2.NOV.2015 20:19:06

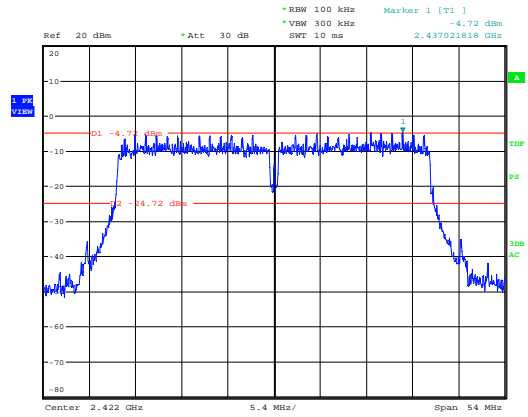

Conducted spurious emissions, mode 11n(40HT), 2422MHz
Date: 2.NOV.2015 20:14:07

Figure 48: Conducted Spurious Emissions in Non-Restricted Frequency Bands, 30MHz - 25GHz, Mode B (2437MHz), 11n(40HT)_Antenna 0

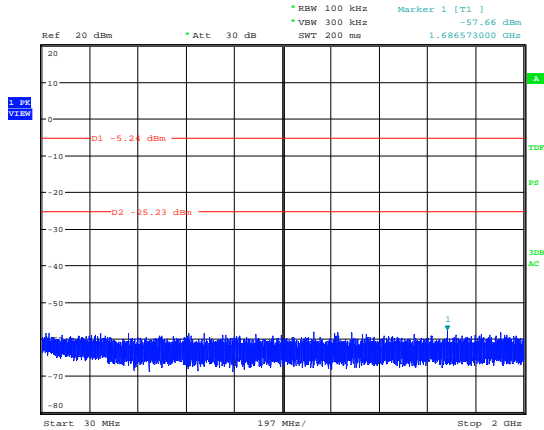

Conducted spurious emissions, mode 11n(40HT), 2447MHz
Date: 2.NOV.2015 20:20:25

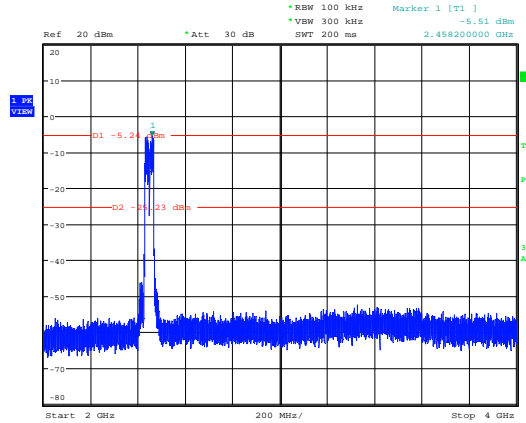

Conducted spurious emissions, mode 11n(40HT), 2447MHz
Date: 2.NOV.2015 20:20:48

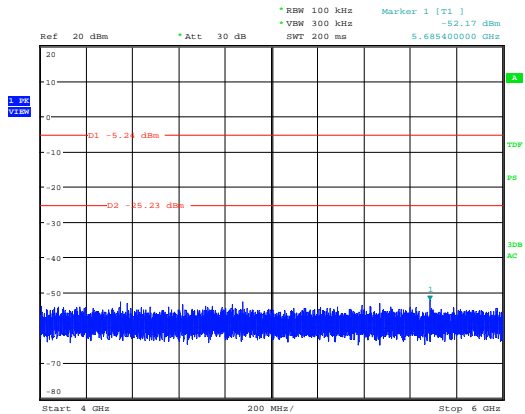

Conducted spurious emissions, mode 11n(40HT), 2447MHz
Date: 2.NOV.2015 20:21:05

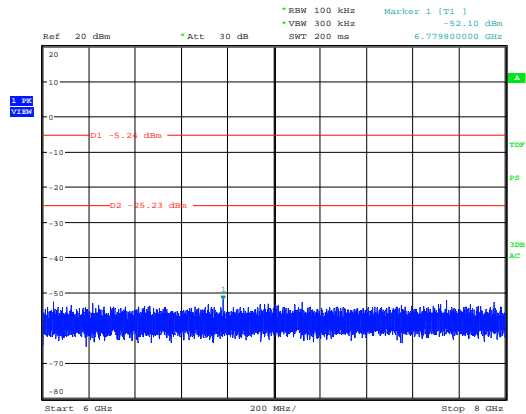

Conducted spurious emissions, mode 11n(40HT), 2447MHz
Date: 2.NOV.2015 20:21:19

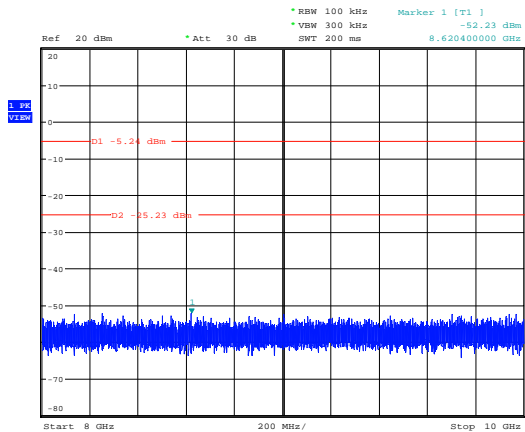

Conducted spurious emissions, mode 11n(40HT), 2447MHz
Date: 2.NOV.2015 20:21:37

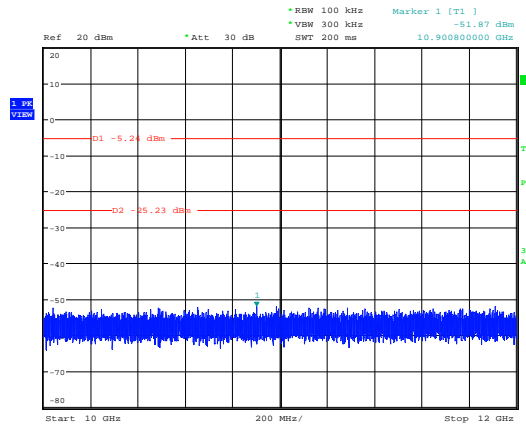

Conducted spurious emissions, mode 11n(40HT), 2447MHz
Date: 2.NOV.2015 20:21:57

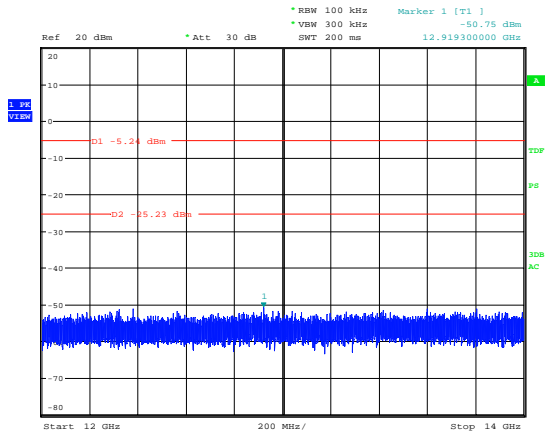

Conducted spurious emissions, mode 11n(40HT), 2447MHz
Date: 2.NOV.2015 20:22:16

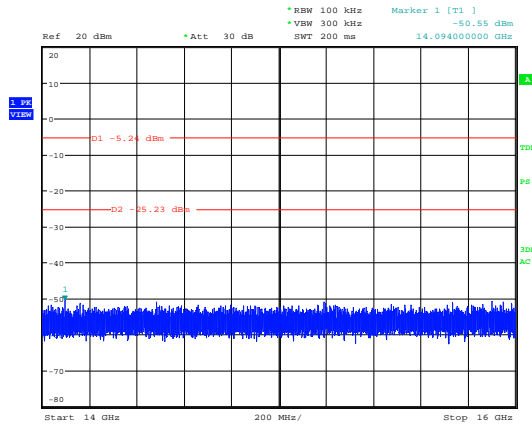

Conducted spurious emissions, mode 11n(40HT), 2447MHz
Date: 2.NOV.2015 20:22:37

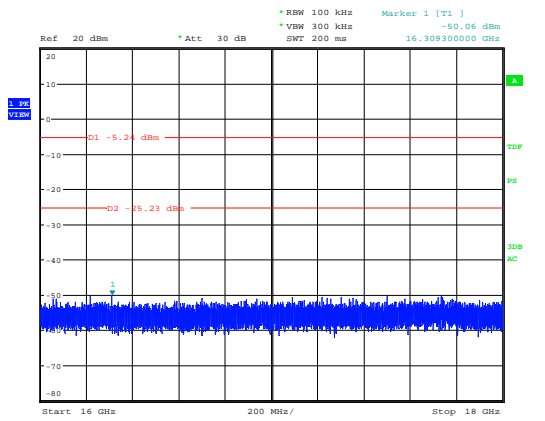

Conducted spurious emissions, mode 11n(40HT), 2447MHz
Date: 2.NOV.2015 20:22:50

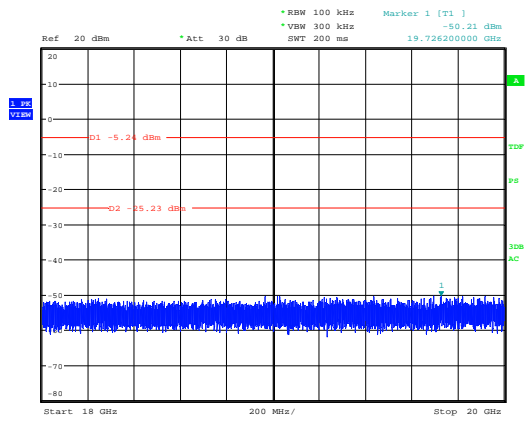

Conducted spurious emissions, mode 11n(40HT), 2447MHz
Date: 2.NOV.2015 20:23:03

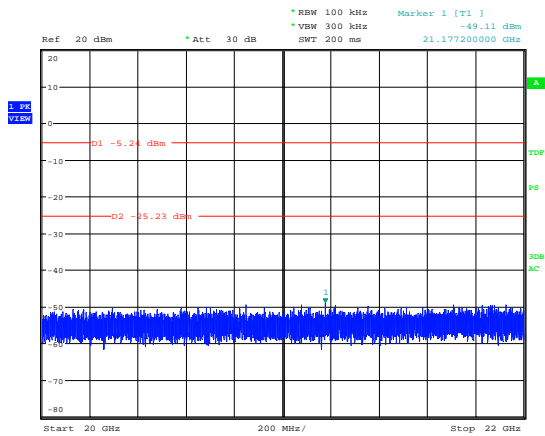

Conducted spurious emissions, mode 11n(40HT), 2447MHz
Date: 2.NOV.2015 20:23:16

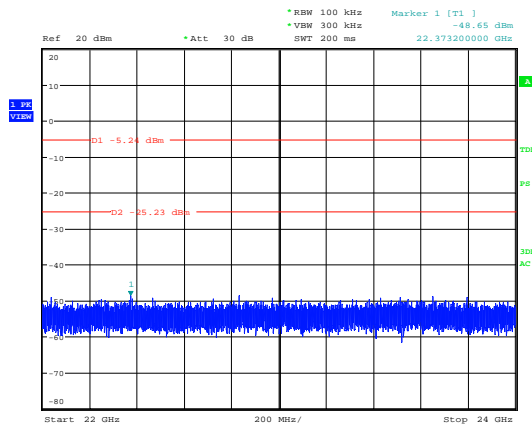

Conducted spurious emissions, mode 11n(40HT), 2447MHz
Date: 2.NOV.2015 20:23:32

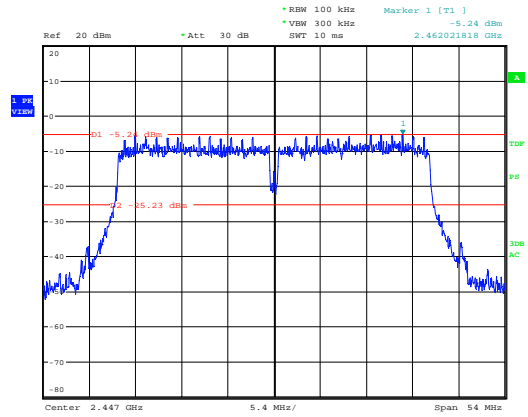
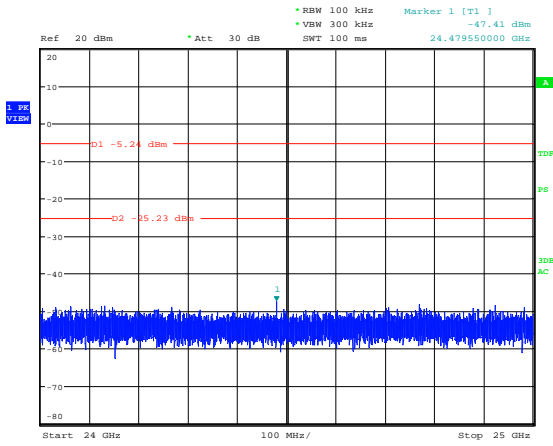

Conducted spurious emissions, mode 11n(40HT), 2447MHz
Date: 2.NOV.2015 20:23:47

Conducted spurious emissions, mode 11n(40HT), 2447MHz
Date: 2.NOV.2015 20:20:12

Figure 49: Conducted Spurious Emissions in Non-Restricted Frequency Bands, 30MHz - 25GHz, Mode C (2452MHz), 11n(40HT)_Antenna 0

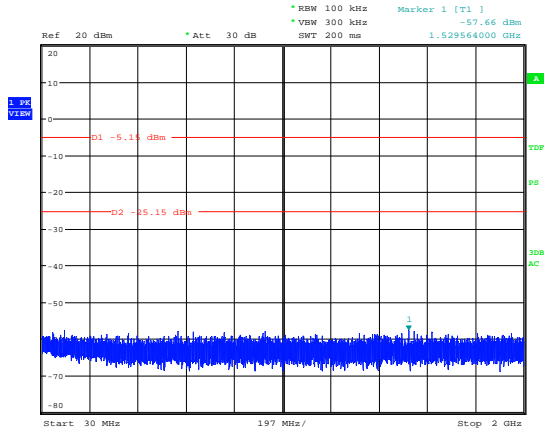

Conducted spurious emissions, mode 11n(40HT), 2452MHz
Date: 2.NOV.2015 20:00:41

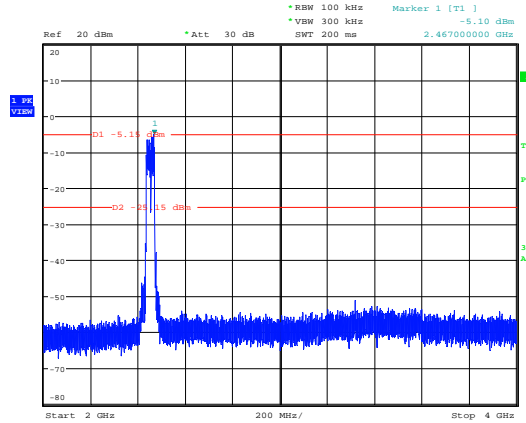

Conducted spurious emissions, mode 11n(40HT), 2452MHz
Date: 2.NOV.2015 20:00:54

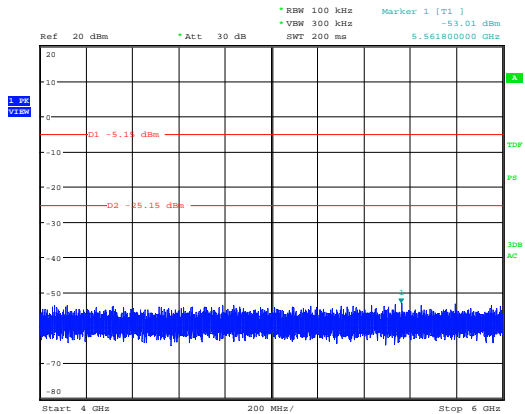

Conducted spurious emissions, mode 11n(40HT), 2452MHz
Date: 2.NOV.2015 20:01:27

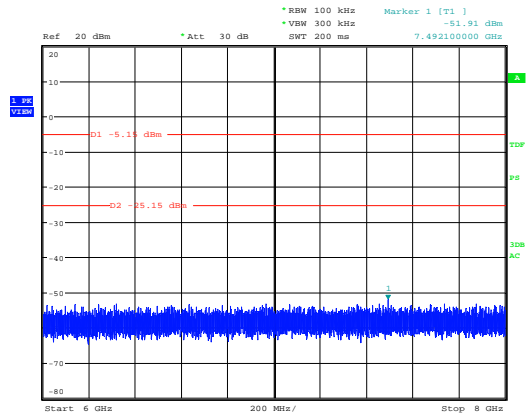

Conducted spurious emissions, mode 11n(40HT), 2452MHz
Date: 2.NOV.2015 20:01:42

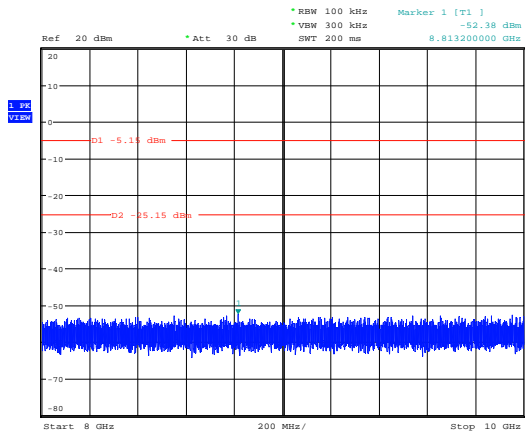

Conducted spurious emissions, mode 11n(40HT), 2452MHz
Date: 2.NOV.2015 20:01:54

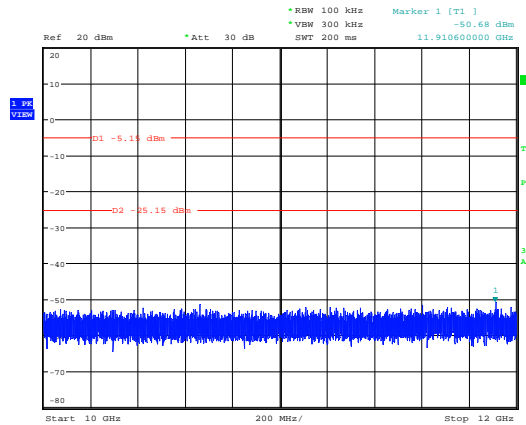

Conducted spurious emissions, mode 11n(40HT), 2452MHz
Date: 2.NOV.2015 20:02:10

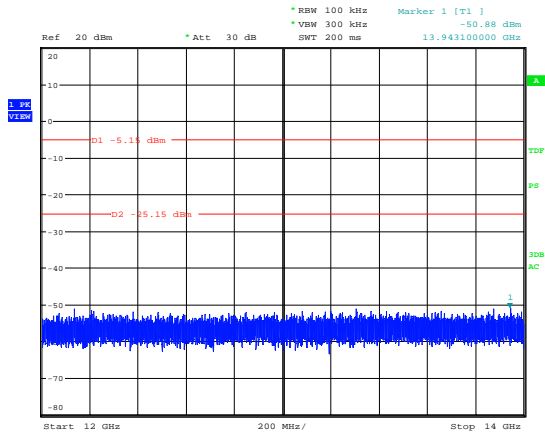

Conducted spurious emissions, mode 11n(40HT), 2452MHz
Date: 2.NOV.2015 20:02:37

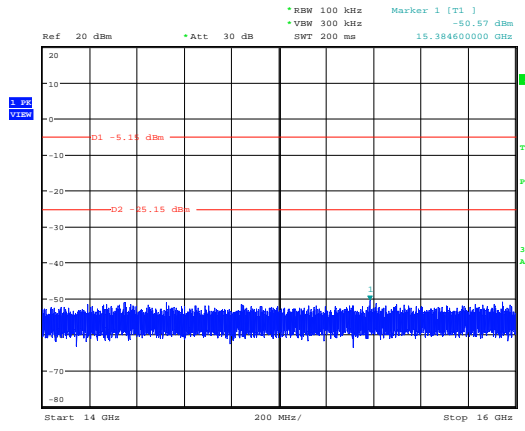

Conducted spurious emissions, mode 11n(40HT), 2452MHz
Date: 2.NOV.2015 20:03:09

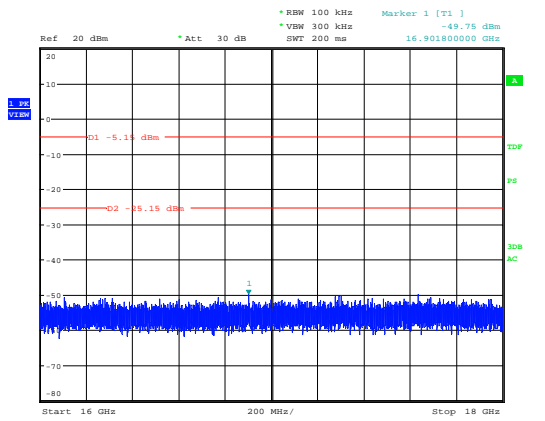

Conducted spurious emissions, mode 11n(40HT), 2452MHz
Date: 2.NOV.2015 20:03:28

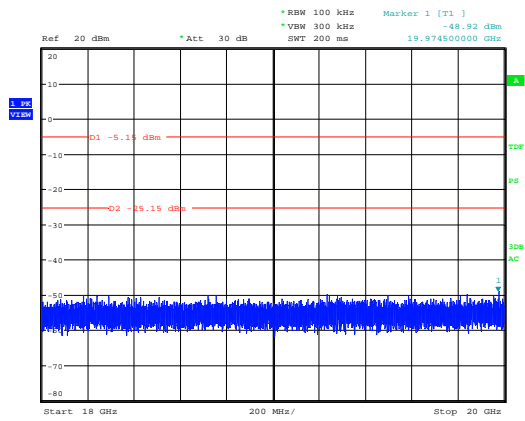

Conducted spurious emissions, mode 11n(40HT), 2452MHz
Date: 2.NOV.2015 20:03:47

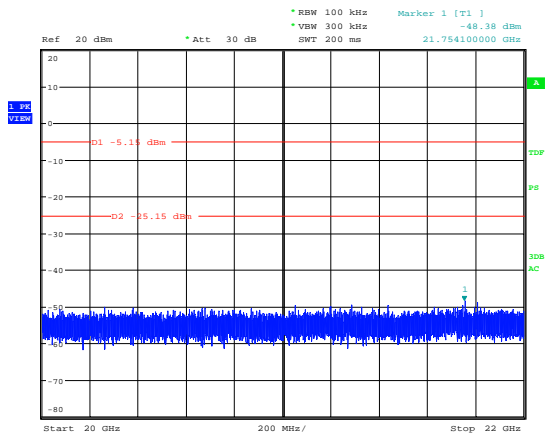

Conducted spurious emissions, mode 11n(40HT), 2452MHz
Date: 2.NOV.2015 20:04:01

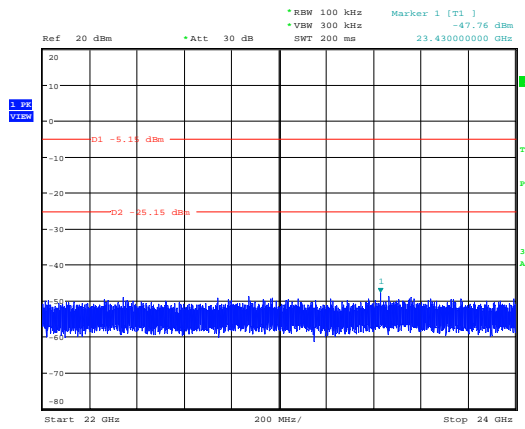

Conducted spurious emissions, mode 11n(40HT), 2452MHz
Date: 2.NOV.2015 20:04:19

Produkte
Products

Prüfbericht - Nr.: **50027424 001**
Test Report No.:

Seite 81 von 123
Page 81 of 123

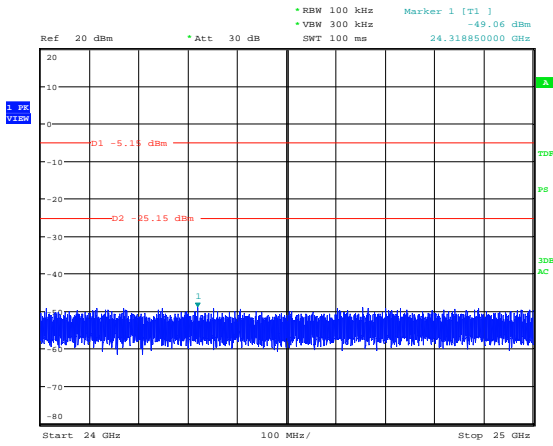

Conducted spurious emissions, mode 11n(40HT), 2452MHz
Date: 2.NOV.2015 20:04:35

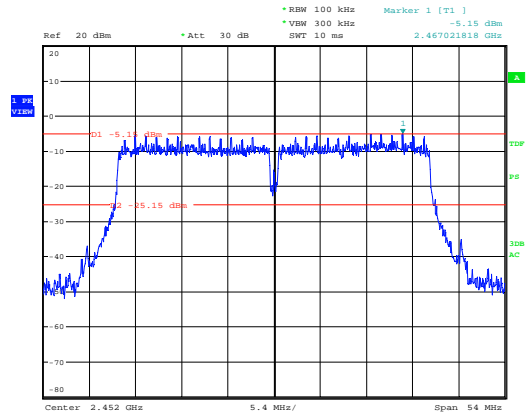

Conducted spurious emissions, mode 11n(40HT), 2452MHz
Date: 2.NOV.2015 20:00:26

Prüfbericht - Nr.: 50027424 001

Seite 82 von 123

Test Report No.:

Page 82 of 123

5.2.5 Peak Power Spectral Density

RESULT:**PASS**

Date of testing: 2015-11-02

Ambient temperature: 24°C

Relative humidity: 46%

Atmospheric pressure: 1012hPa

Requirements:

FCC 15.247(e) and RSS-247 5.2 (2)

For digitally modulated systems, the power spectral density (PSD) conducted from the intentional radiator to the antenna shall not be greater than 8dBm in any 3kHz band during any time interval of continuous transmission.

Test procedure:

ANSI C63.10-2013, KDB Publication No. 558074 D01 and KDB Publication No. 662911 D01.

The peak power spectral density was measured at the antenna port with a spectrum analyzer using a peak detector with a resolution bandwidth of 3kHz and a video bandwidth of 10kHz.

The readings of the measurements take into account the loss generated by all the involved cables.

Note:

Directional gain = $2.17\text{dBi} + 10\log(2) = 5.18\text{ dBi} < 6\text{ dBi}$, so the power density limit shall be 8 dBm.

For protocols IEEE 802.11b and g, final measurements were carried out on Antenna 0, selected as the worst case antenna port, since Antenna 0 shows the highest data for Conducted Output Power.

Table 23: Peak Power Spectral Density, 11b_Antenna 0

Operating Frequency [MHz]	Max PSD Frequency [MHz]	Max PSD [dBm]	Limit [dBm]	Margin [dB]
2412MHz	2412.51	-10.35	8	18.35
2437MHz	2437.51	-10.59	8	18.59
2462MHz	2461.51	-10.74	8	18.74

Figure 50: Power Spectral Density, Mode A (2412MHz), 11b_Antenna 0

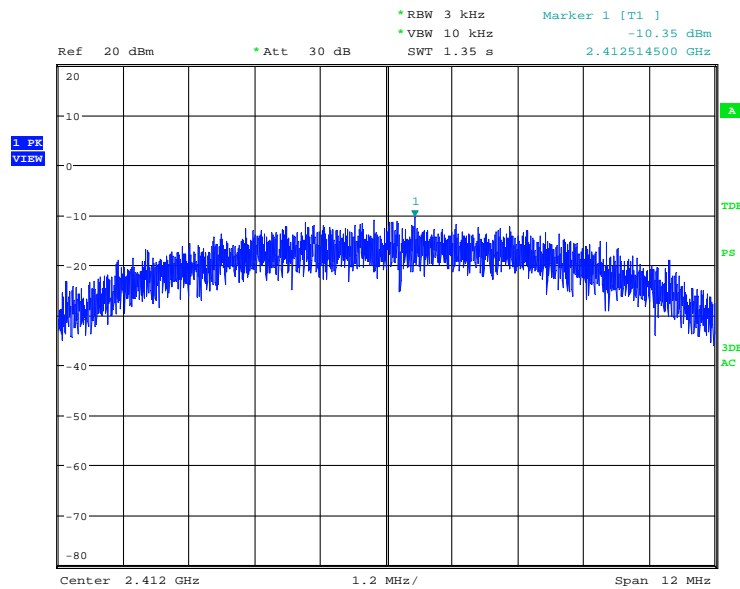

Peak power spectral density, mode 11b, 2412MHz
Date: 2.NOV.2015 16:44:08

Figure 51: Power Spectral Density, Mode B (2437MHz), 11b_Antenna 0

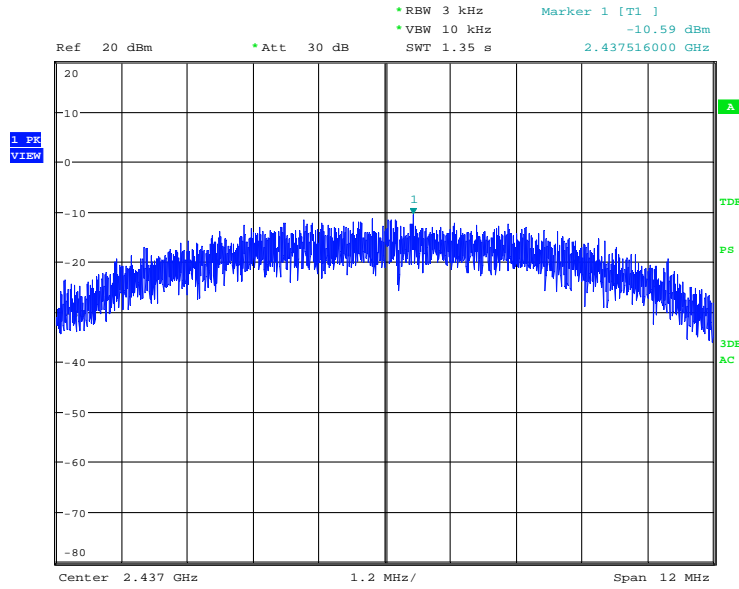

Peak power spectral density, mode 11b, 2437MHz
Date: 2.NOV.2015 16:56:36

Figure 52: Power Spectral Density, Mode C (2462MHz), 11b_Antenna 0

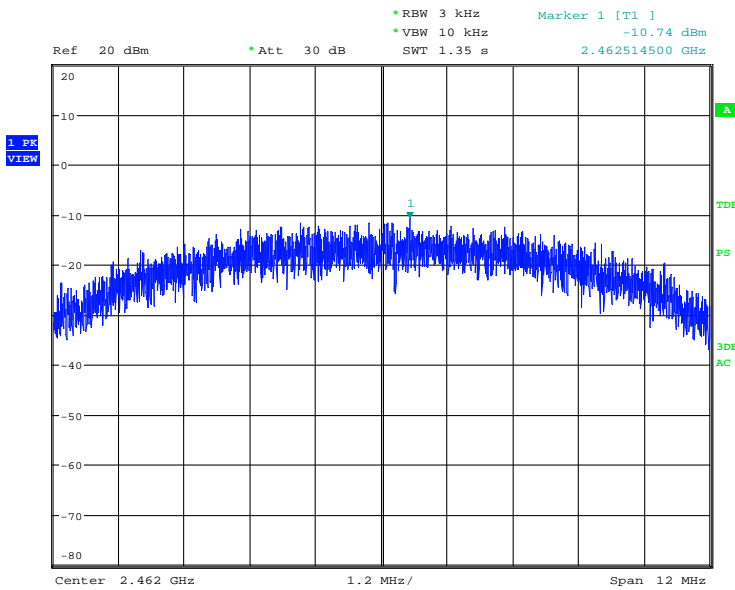

Peak power spectral density, mode 11b, 2462MHz
Date: 2.NOV.2015 17:04:15

Table 24: Peak Power Spectral Density, 11g_Antenna 0

Operating Frequency [MHz]	Max PSD Frequency [MHz]	Max PSD [dBm]	Limit [dBm]	Margin [dB]
2412MHz	2417.92	-16.19	8	24.19
2437MHz	2444.49	-15.75	8	23.75
2462MHz	2467.65	-15.66	8	23.66

Figure 53: Power Spectral Density, Mode A (2412MHz), 11g_Antenna 0

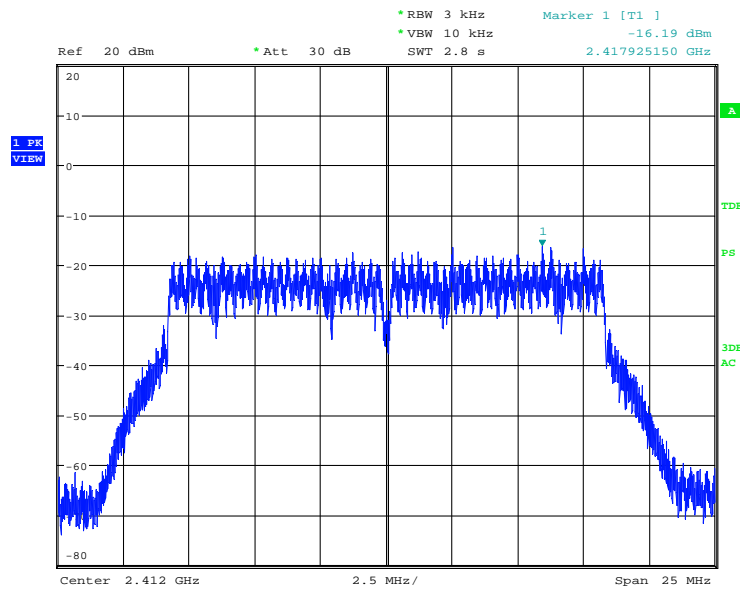

Peak power spectral density, mode 11g, 2412MHz
 Date: 2.NOV.2015 17:55:04

Figure 54: Power Spectral Density, Mode B (2437MHz), 11g_Antenna 0

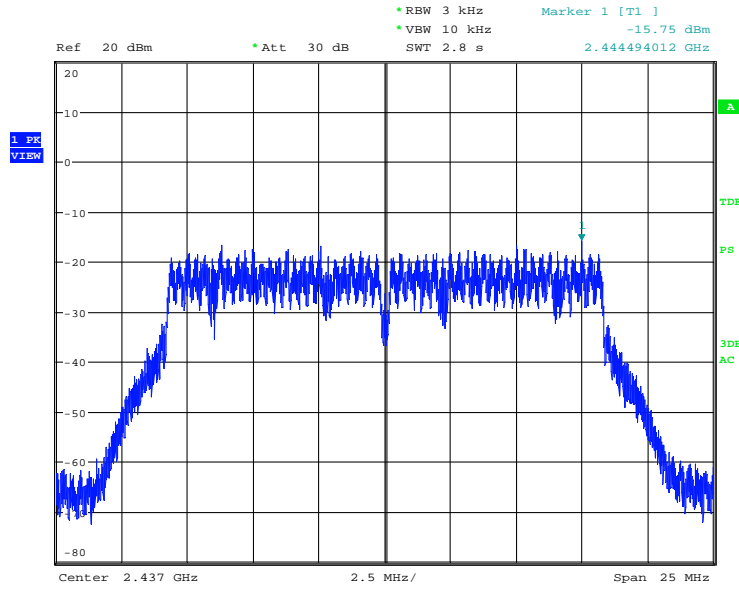

Peak power spectral density, mode 11g, 2437MHz
Date: 2.NOV.2015 17:17:03

Figure 55: Power Spectral Density, Mode C (2462MHz), 11g_Antenna 0

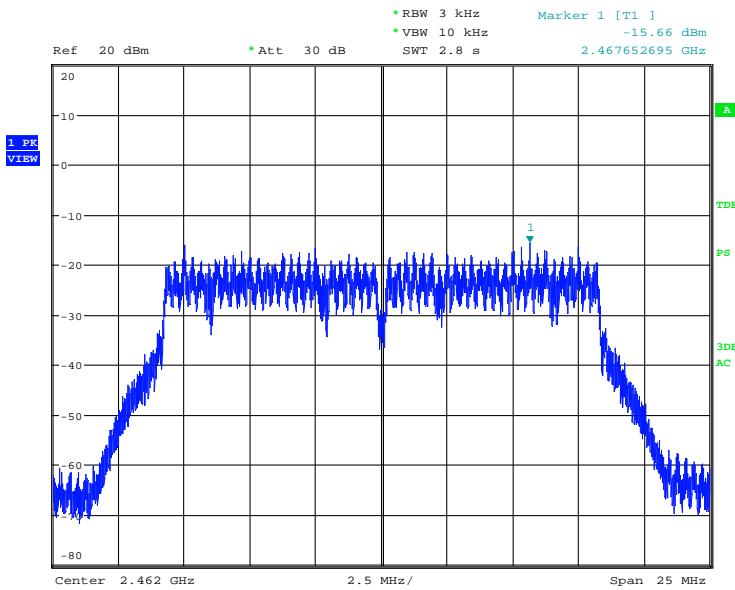

Peak power spectral density, mode 11g, 2462MHz
Date: 2.NOV.2015 17:39:07

Table 25: Peak Power Spectral Density, 11n(20HT)_Antenna 0

Operating Frequency [MHz]	Max PSD Frequency [MHz]	Max PSD Reading [dBm]	Antenna Factor [dB]	Max PSD [dBm]	Limit [dBm]	Margin [dB]
2412MHz	2416.97	-15.57	3.01	-12.56	8	20.56
2437MHz	2443.28	-13.28	3.01	-13.27	8	21.27
2462MHz	2468.28	-13.38	3.01	-13.37	8	21.37

Note:

Antenna Factor = 2 antenna system correction factor = $10 \times \log(2)$
 Max PSD = Max PSD reading + Antenna factor

Figure 56: Power Spectral Density, Mode A (2412MHz), 11n(20HT)_Antenna 0

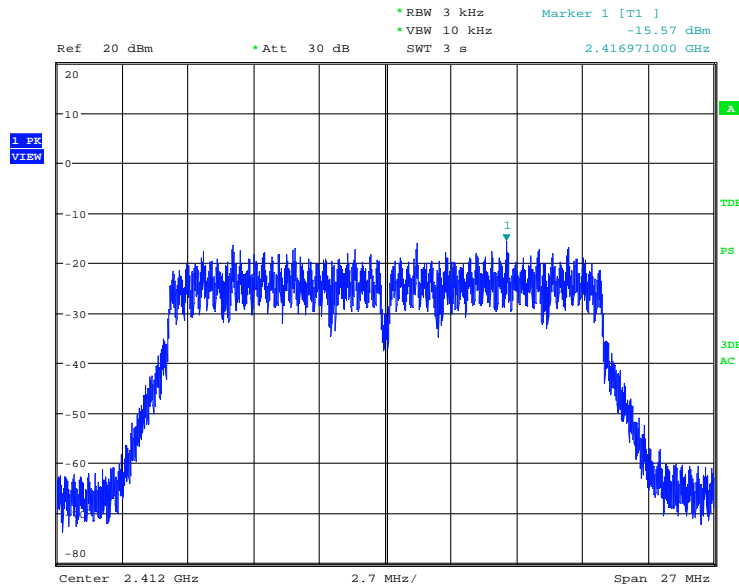

Peak power spectral density, mode 11n(20HT), 2412MHz
 Date: 2.NOV.2015 17:51:33

Figure 57: Power Spectral Density, Mode B (2437MHz), 11n(20HT)_Antenna 0

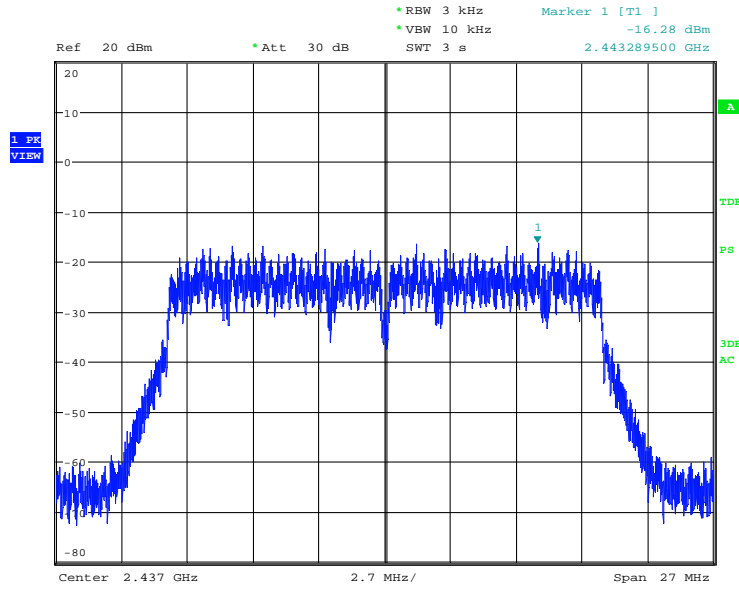

Peak power spectral density, mode 11n(20HT), 2437MHz
Date: 2.NOV.2015 17:48:04

Figure 58: Power Spectral Density, Mode C (2462MHz), 11n(20HT)_Antenna 0

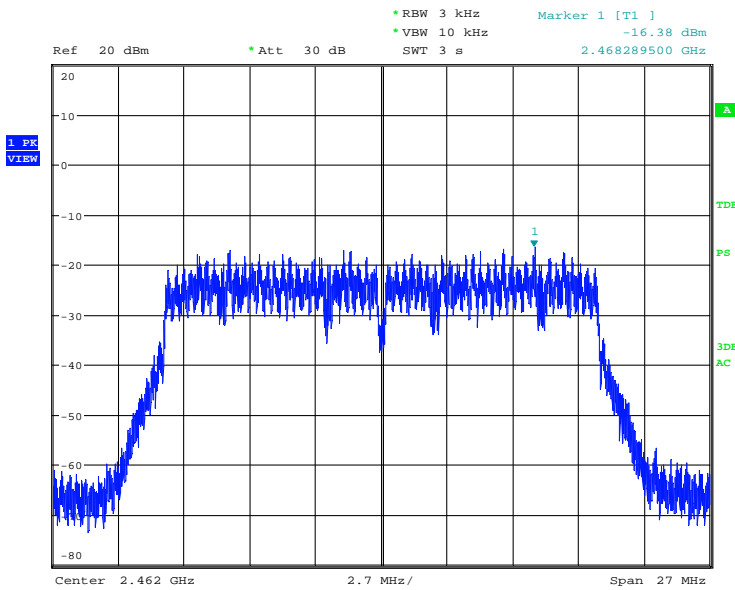

Peak power spectral density, mode 11n(20HT), 2462MHz
Date: 2.NOV.2015 17:43:14

Table 26: Peak Power Spectral Density, 11n(20HT)_Antenna 1

Operating Frequency [MHz]	Max PSD Frequency [MHz]	Max PSD Reading [dBm]	Antenna Factor [dB]	Max PSD [dBm]	Limit [dBm]	Margin [dB]
2412MHz	2430.74	-16.39	3.01	-13.38	8	23.38
2437MHz	2461.99	-16.20	3.01	-13.19	8	23.19
2462MHz	2435.78	-16.61	3.01	-13.60	8	21.60

Note:

Antenna Factor = 2 antenna system correction factor = 10 x log(2)
Max PSD = Max PSD reading + Antenna factor

Figure 59: Power Spectral Density, Mode A (2412MHz), 11n(20HT)_Antenna 1

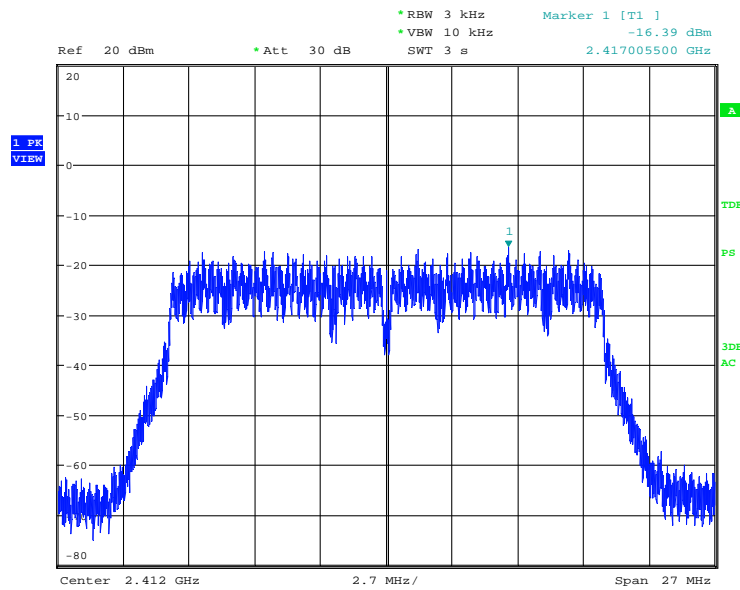

Peak power spectral density, mode 11n(20HT), 2412MHz, Ant1
Date: 2.NOV.2015 18:26:36

Figure 60: Power Spectral Density, Mode B (2437MHz), 11n(20HT)_Antenna 1

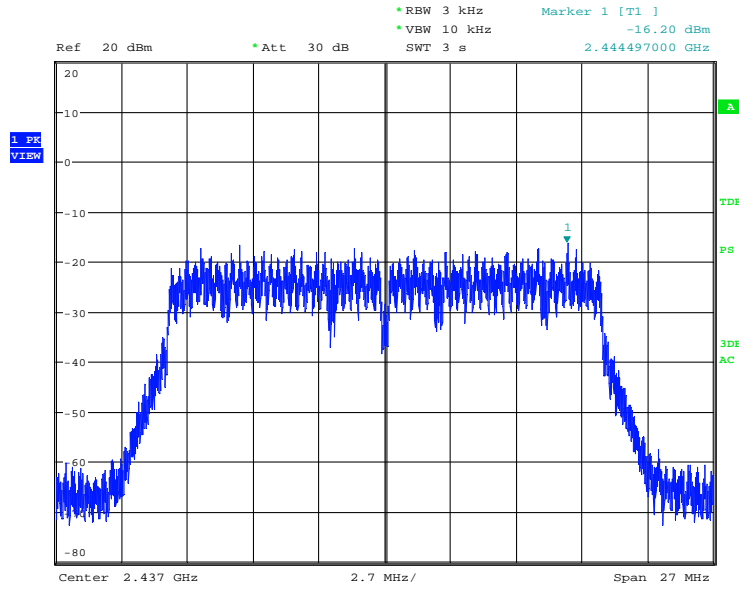

Peak power spectral density, mode 11n(20HT), 2437MHz, Ant1
Date: 2.NOV.2015 18:28:51

Figure 61: Power Spectral Density, Mode C (2462MHz), 11n(20HT)_Antenna 1

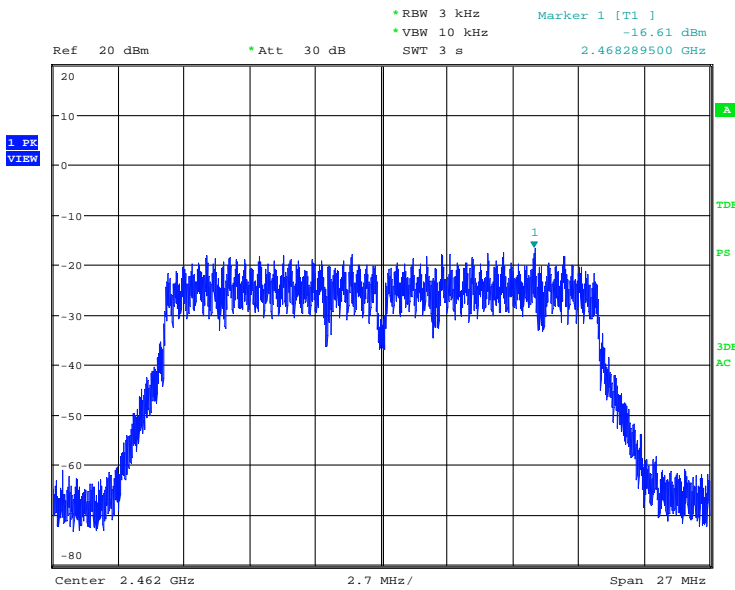

Peak power spectral density, mode 11n(20HT), 2462MHz, Ant1
Date: 2.NOV.2015 18:30:56

Table 27: Peak Power Spectral Density, 11n(40HT)_Antenna 0

Operating Frequency [MHz]	Max PSD Frequency [MHz]	Max PSD Reading [dBm]	Antenna Factor [dB]	Max PSD [dBm]	Limit [dBm]	Margin [dB]
2422	2437.00	-17.43	3.01	-14.42	8	22.42
2447	2459.46	-19.01	3.01	-16.00	8	24.00
2452	2466.99	-18.03	3.01	-15.02	8	25.02

Note:

Antenna Factor = 2 antenna system correction factor = $10 \times \log(2)$
 Max PSD = Max PSD reading + Antenna factor

Figure 62: Power Spectral Density, Mode A (2422MHz), 11n(40HT)_Antenna 0

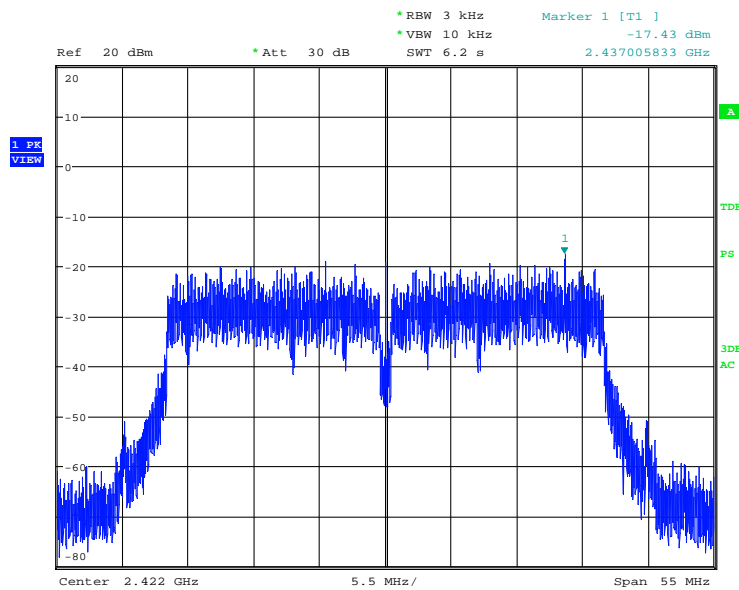

Peak power spectral density, mode 11n(40HT), 2422MHz
 Date: 2.NOV.2015 18:07:36

Figure 63: Power Spectral Density, Mode B (2447MHz), 11n(40HT)_Antenna 0

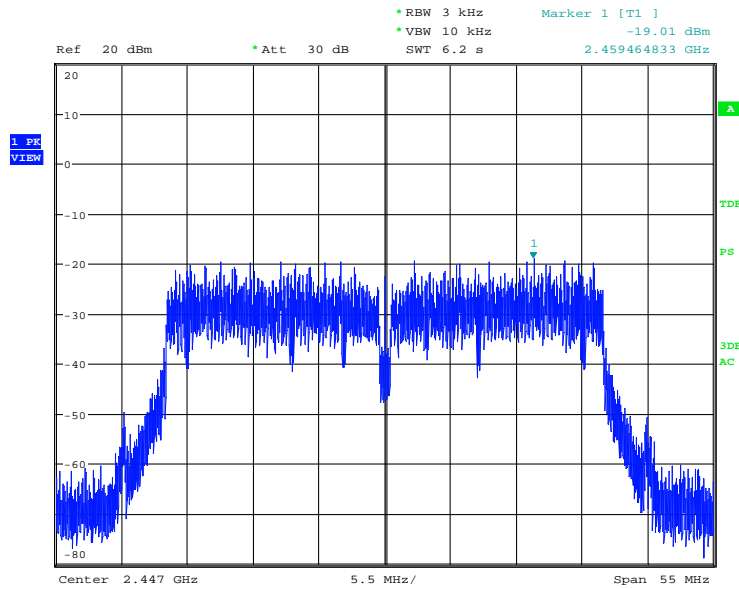

Peak power spectral density, mode 11n(40HT), 2447MHz
Date: 2.NOV.2015 18:10:48

Figure 64: Power Spectral Density, Mode C (2452MHz), 11n(40HT)_Antenna 0

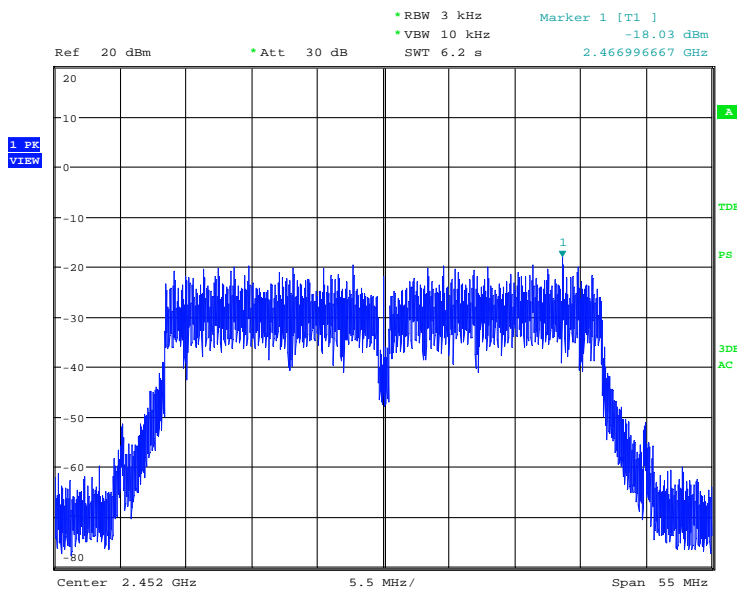

Peak power spectral density, mode 11n(40HT), 2452MHz
Date: 2.NOV.2015 18:13:26

Table 28: Peak Power Spectral Density, 11n(40HT)_Antenna 1

Operating Frequency [MHz]	Max PSD Frequency [MHz]	Max PSD Reading [dBm]	Antenna Factor [dB]	Max PSD [dBm]	Limit [dBm]	Margin [dB]
2422	2430.74	-18.39	3.01	-15.38	8	23.38
2447	2461.99	-18.52	3.01	-15.51	8	23.51
2452	2435.78	-18.72	3.01	-15.71	8	23.71

Note:

Antenna Factor = 2 antenna system correction factor = 10 x log(2)
Max PSD = Max PSD reading + Antenna factor

Figure 65: Power Spectral Density, Mode A (2422MHz), 11n(40HT)_Antenna 1

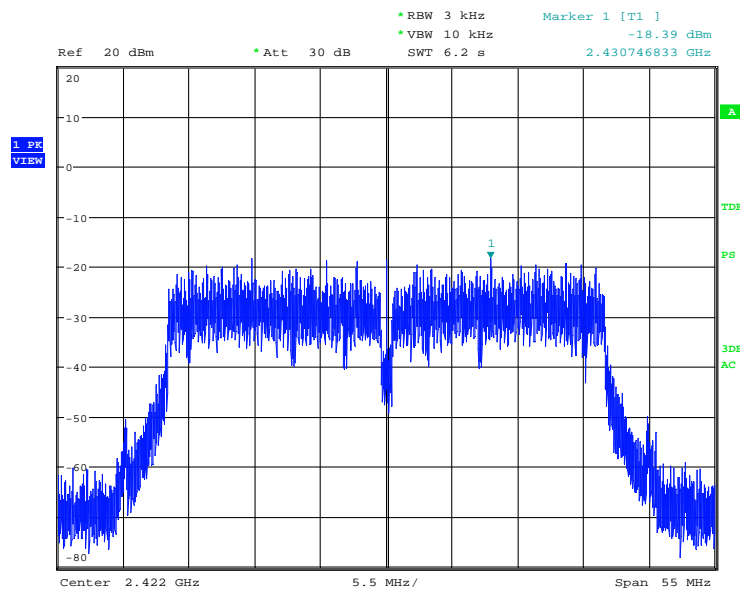

Peak power spectral density, mode 11n(40HT), 2422MHz, Ant1
Date: 2.NOV.2015 18:22:28

Figure 66: Power Spectral Density, Mode B (2447MHz), 11n(40HT)_Antenna 1

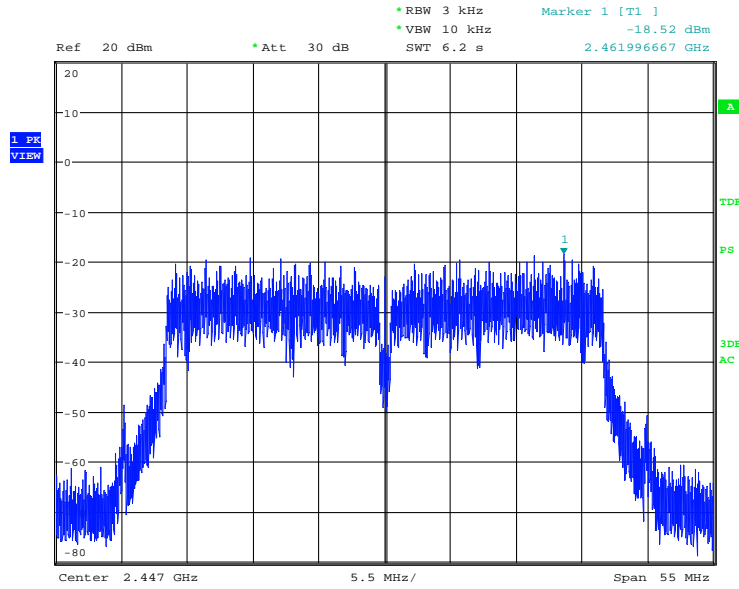

Peak power spectral density, mode 11n(40HT), 2447MHz, Ant1
Date: 2.NOV.2015 18:19:46

Figure 67: Power Spectral Density, Mode C (2452MHz), 11n(40HT)_Antenna 1

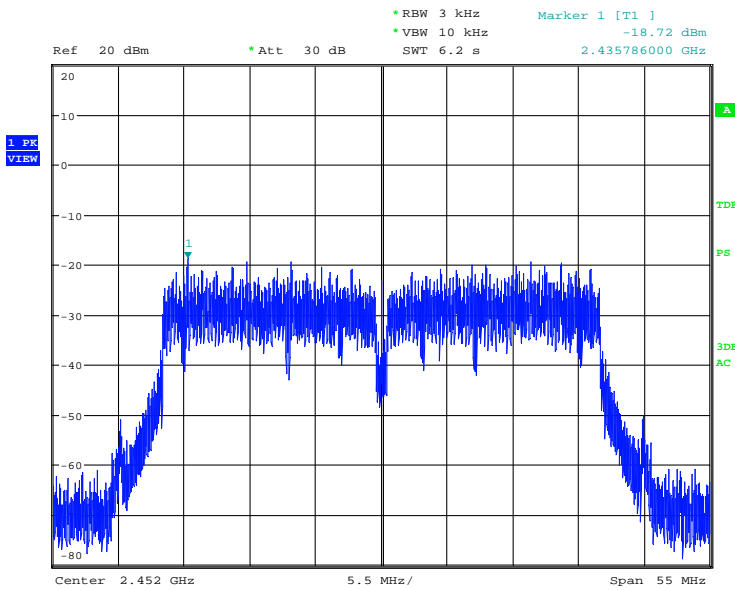

Peak power spectral density, mode 11n(40HT), 2452MHz, Ant1
Date: 2.NOV.2015 18:17:09

5.3 Radiated Measurements

5.3.1 Radiated Spurious Emissions of Transmitter

RESULT:
PASS

Date of testing:	2015-05-25, 2015-05-26, 2015-05-27, 2015-05-28, 2015-06-04
Ambient temperature:	21, 21, 22, 21, 21°C
Relative humidity:	25, 25, 26, 25, 25%
Atmospheric pressure:	1010, 1009, 1009, 1011, 1008hPa

Requirements:

FCC 15.205, FCC 15.209, FCC 15.247(d), RSS-Gen 8.9 and 8.10 and RSS-247 3.1

Radiated emissions which fall in the restricted bands, as defined in FCC 15.205(a) and RSS-Gen 8.10 (table 6), must comply with the radiated emission limits specified in FCC 15.209(a) and RSS-Gen 8.9 (tables 4 and 5).

Radiated emissions which fall outside the operation frequency band and outside restricted bands shall either meet the limit specified in FCC 15.209(a) and RSS-Gen 8.9 or be attenuated at least 20dB below the power level in the 100kHz bandwidth within the band that contains the highest level of the desired power (the less severe limit applies).

Test procedure:

ANSI C63.10-2013 RSS-Gen 6.13 and 8.1 and KDB Publication No. 558074 D01.

The EUT was placed on a nonconductive turntable 0.8m above the ground plane. Before final measurements of radiated emissions were performed, the EUT was scanned to determine its emission spectrum profile. The physical arrangement of the test system, the associated cabling and the EUT orientation (X, Y) were varied in order to ensure that maximum emission amplitudes were attained.

The spectrum was examined from 9kHz to the 10th harmonic of the highest fundamental transmitter frequency (25GHz). Final radiated emission measurements were made at 3m distance.

At each frequency where a spurious emission was found, the EUT was rotated 360° and the antenna was raised and lowered from 1 to 4m in order to determine the emission's maximum level. Measurements were taken using both horizontal and vertical antenna polarizations.

For emissions between 30MHz and 1GHz, measurements were performed with a test receiver operating in the CISPR quasi-peak detection mode. The receiver's 6dB bandwidth was set to 120kHz. For emissions above 1GHz, measurements were performed with a spectrum analyzer using the following settings: for peak field strength: RBW = 1MHz & VBW ≥ 1MHz; for average field strength: RBW = 1MHz & VBW = 10Hz.

Prüfbericht - Nr.: 50027424 001**Seite 96 von 123***Test Report No.:**Page 96 of 123*

Absorbers have been placed on the floor between the EUT and the measuring antenna for testing above 1GHz.

The highest emission amplitudes relative to the appropriate limit were recorded in this report. Emissions other than those mentioned are small or not detectable.

No spurious emission was found in the range 9kHz - 30MHz.

Prechecks for all test modes were carried out, and the final test were carried out for the worst case mode, reported here below.

Prüfbericht - Nr.: 50027424 001
Seite 97 von 123

Test Report No.:

Page 97 of 123

Table 29: Radiated Emissions, Quasi Peak Data, 30MHz - 1GHz, Horizontal and Vertical Antenna Orientations, Mode A (2412MHz), 11b

Freq. [MHz]	EUT / Antenna Orientation	Reading QP [dBµV]	Factor [dB(1/m)]	Level QP [dBµV/m]	Limit [dBµV/m]	Margin QP [dB]	Height [cm]	Angle [°]
38.459	Y/V	51.0	-17.5	33.5	40.0	6.5	108	191
41.074	Y/V	53.5	-18.1	35.4	40.0	4.6(*)	100	172
56.891	Y/V	49.0	-15.9	33.1	40.0	6.9	103	254
165.886	Y/H	49.7	-14.7	35.0	43.5	8.5	100	115
167.939	Y/V	50.5	-14.8	35.7	43.5	7.8	100	94
188.417	Y/H	52.2	-16.6	35.6	43.5	7.9	139	117
541.289	Y/V	35.8	-6.8	29.0	46.0	17.0	100	320
643.071	Y/H	44.4	-5.4	39.0	46.0	7.0	108	56
719.995	Y/V	44.4	-5.3	39.1	46.0	6.9	155	82

Note: Level QP = Reading QP + Factor

(*) Note: For measured result(s) below the specification limit by a margin less than the measurement uncertainty as shown in " Table 2: Emission Measurement Uncertainty"; it is therefore not possible to determine compliance at a level of confidence of 95%. However, the measured result indicates a high probability that the tested product complies with the specification limit.

Table 30: Radiated Emissions, Average Data, 1 - 25GHz, Horizontal and Vertical Antenna Orientations, Mode A (2412MHz), 11b

Freq. [MHz]	EUT / Antenna Orientation	Reading AV [dBµV]	Factor [dB(1/m)]	Level AV [dBµV/m]	Limit [dBµV/m]	Margin AV [dB]	Height [cm]	Angle [°]
4823.988	Y/H	48.7	-7.1	41.6	54	12.4	165	92
9647.960	Y/H	50.7	-8.7	42.0	54	12.0	171	232
23264.778	Y/H	38.6	-11.9	26.7	54	27.3	181	135

Note: Level AV = Reading AV + Factor

Table 31: Radiated Emissions, Peak Data, 1 - 25GHz, Horizontal and Vertical Antenna Orientations, Mode A (2412MHz), 11b

Freq. [MHz]	EUT / Antenna Orientation	Reading PK [dBµV]	Factor [dB(1/m)]	Level PK [dBµV/m]	Limit [dBµV/m]	Margin PK [dB]	Height [cm]	Angle [°]
4823.988	Y/H	55.3	-7.1	48.2	74	25.8	165	92
9647.960	Y/H	55.9	-8.7	47.2	74	26.8	171	232
23264.778	Y/H	52.6	-11.9	40.7	74	33.3	181	135

Note: Level PK = Reading PK + Factor

Table 32: Radiated Emissions, Average Data, 1 - 25GHz, Horizontal and Vertical Antenna Orientations, Mode B (2437MHz), 11b

Freq. [MHz]	EUT Orientation	Reading AV [dBµV]	Factor [dB(1/m)]	Level AV [dBµV/m]	Limit [dBµV/m]	Margin AV [dB]	Height [cm]	Angle [°]
4874.05	Y/H	53.3	-7.2	46.1	54	7.9	175	87
9747.96	Y/H	49.8	-7.8	42.0	54	12.0	158	215

Note: Level AV = Reading AV + Factor

Table 33: Radiated Emissions, Peak Data, 1 - 25GHz, Horizontal and Vertical Antenna Orientations, Mode B (2437MHz), 11b

Freq. [MHz]	EUT / Antenna Orientation	Reading PK [dBµV]	Factor [dB(1/m)]	Level PK [dBµV/m]	Limit [dBµV/m]	Margin PK [dB]	Height [cm]	Angle [°]
4874.05	Y/H	58.2	-7.2	51.0	74	23.0	175	87
9747.96	Y/H	55.2	-7.8	47.4	74	26.6	158	215

Note: Level PK = Reading PK + Factor

Table 34: Radiated Emissions, Average Data, 1 - 25GHz, Horizontal and Vertical Antenna Orientations, Mode C (2462MHz), 11b

Freq. [MHz]	EUT / Antenna Orientation	Reading AV [dB μ V]	Factor [dB(1/m)]	Level AV [dB μ V/m]	Limit [dB μ V/m]	Margin AV [dB]	Height [cm]	Angle [°]
4924.007	Y/H	56.5	-7.1	49.4	54	4.6	170	88
9847.970	Y/H	50.2	-7.6	42.6	54	11.4	159	222
21374.480	Y/H	37.7	-11.0	26.7	54	27.3	100	146

Note: Level AV = Reading AV + Factor

Table 35: Radiated Emissions, Peak Data, 1 - 25GHz, Horizontal and Vertical Antenna Orientations, Mode C (2462MHz), 11b

Freq. [MHz]	EUT / Antenna Orientation	Reading PK [dB μ V]	Factor [dB(1/m)]	Level PK [dB μ V/m]	Limit [dB μ V/m]	Margin PK [dB]	Height [cm]	Angle [°]
4924.007	Y/H	60.4	-7.1	53.3	74	20.7	170	88
9847.970	Y/H	55.0	-7.6	47.4	74	26.6	159	222
21374.480	Y/H	52.0	-11.0	41.0	74	33.0	100	146

Note: Level PK = Reading PK + Factor

Table 36: Radiated Emissions at Band Edge, Average and Peak Data, Horizontal and Vertical Antenna Orientations, Modes A (2412MHz) and C (2462MHz), 11b

Operating Frequency [MHz]	EUT / Antenna Orientation	Level AV [dB μ V/m]	Level PK [dB μ V/m]	Limit AV [dB μ V/m]	Limit PK [dB μ V/m]	Margin AV [dB]	Margin PK [dB]
2388.496	Y/H	47.25	-	54	-	6.75	-
2388.256	Y/H	-	65.92	-	74	-	8.08
2448.236	Y/H	47.42	-	54	-	6.58	-
2487.164	Y/H	-	65.59	-	74	-	8.41

Notes: All correction factors (antenna, cable, pre-amplifier) are included in the measurement values.

Average limit in dB μ V/m is calculated as follows: Average limit = 20 x log(500 μ V/m).

Peak limit in dB μ V/m is calculated as follows: Peak limit = Average limit + 20dB.

Figure 68: Radiated Spurious Emissions at Band Edge, Mode A (2412MHz), 11b

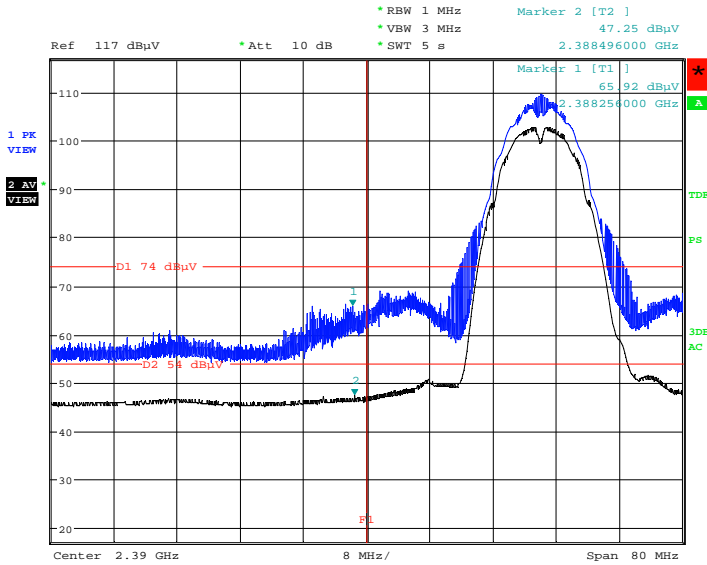

BE, 11b, ModeA, Y, H,150
Date: 26.MAY.2015 19:36:31

Note: The upper trace shows the peak value and the lower trace shows the average value.

Figure 69: Radiated Spurious Emissions at Band Edge, Mode C (2462MHz), 11b

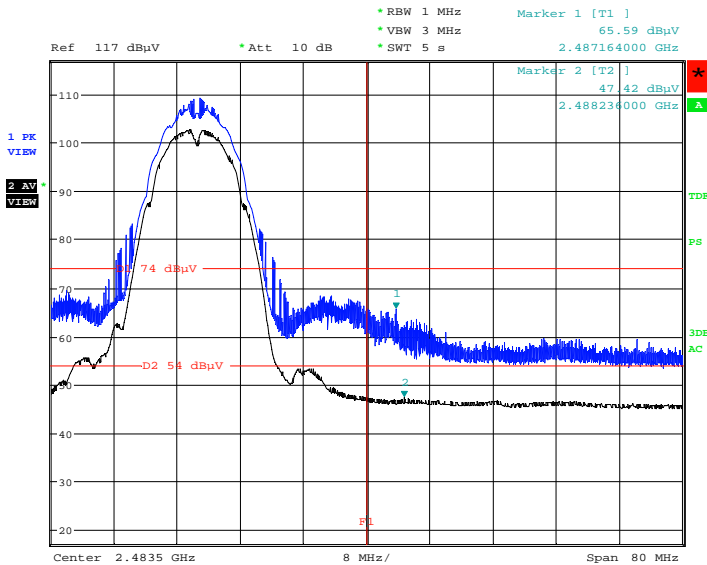

BE, 11b, ModeC, Y, H,150
Date: 26.MAY.2015 19:41:54

Note: The upper trace shows the peak value and the lower trace shows the average value.

Table 37: Radiated Emissions, Average Data, 1 - 25GHz, Horizontal and Vertical Antenna Orientations, Mode A (2412MHz), 11g

Freq. [MHz]	EUT / Antenna Orientation	Reading AV [dBµV]	Factor [dB(1/m)]	Level AV [dBµV/m]	Limit [dBµV/m]	Margin AV [dB]	Height [cm]	Angle [°]
4824.280	Y/H	38.3	-7.1	31.2	54	22.8	129	339
9647.970	Y/H	51.1	-8.7	42.4	54	11.6	101	213
21769.334	Y/H	37.7	-11.0	26.7	54	27.3	132	273

Note: Level AV = Reading AV + Factor

Table 38: Radiated Emissions, Peak Data, 1 - 25GHz, Horizontal and Vertical Antenna Orientations, Mode A (2412MHz), 11g

Freq. [MHz]	EUT / Antenna Orientation	Reading PK [dBµV]	Factor [dB(1/m)]	Level PK [dBµV/m]	Limit [dBµV/m]	Margin PK [dB]	Height [cm]	Angle [°]
4824.280	Y/H	52.5	-7.1	45.4	74	28.6	129	339
9647.970	Y/H	55.9	-8.7	47.2	74	26.8	101	213
21769.334	Y/H	51.8	-11.0	40.8	74	33.2	132	273

Note: Level PK = Reading PK + Factor

Table 39: Radiated Emissions, Average Data, 1 - 25GHz, Horizontal and Vertical Antenna Orientations, Mode B (2437MHz), 11g

Freq. [MHz]	EUT / Antenna Orientation	Reading AV [dBµV]	Factor [dB(1/m)]	Level AV [dBµV/m]	Limit [dBµV/m]	Margin AV [dB]	Height [cm]	Angle [°]
4874.340	Y/H	53.0	-7.2	45.8	54	8.2	173	90
9748.120	Y/H	48.9	-7.8	41.1	54	12.9	155	219

Note: Level AV = Reading AV + Factor

Table 40: Radiated Emissions, Peak Data, 1 - 25GHz, Horizontal and Vertical Antenna Orientations, Mode B (2437MHz), 11g

Freq. [MHz]	EUT / Antenna Orientation	Reading PK [dBµV]	Factor [dB(1/m)]	Level PK [dBµV/m]	Limit [dBµV/m]	Margin PK [dB]	Height [cm]	Angle [°]
4874.340	Y/H	57.9	-7.2	50.7	74	23.3	173	90
9748.120	Y/H	54.5	-7.8	46.7	74	27.3	155	219

Note: Level PK = Reading PK + Factor

Table 41: Radiated Emissions, Average Data, 1 - 25GHz, Horizontal and Vertical Antenna Orientations, Mode C (2462MHz), 11g

Freq. [MHz]	EUT / Antenna Orientation	Reading AV [dB μ V]	Factor [dB(1/m)]	Level AV [dB μ V/m]	Limit [dB μ V/m]	Margin AV [dB]	Height [cm]	Angle [°]
4924.099	Y/H	45.8	-7.1	38.7	54	15.3	104	95
9847.960	Y/H	49.7	-7.6	42.1	54	11.9	106	205
24062.060	Y/H	40.0	-12.4	27.6	54	26.4	125	338

Note: Level AV = Reading AV + Factor

Table 42: Radiated Emissions, Peak Data, 1 - 25GHz, Horizontal and Vertical Antenna Orientations, Mode C (2462MHz), 11g

Freq. [MHz]	EUT / Antenna Orientation	Reading PK [dB μ V]	Factor [dB(1/m)]	Level PK [dB μ V/m]	Limit [dB μ V/m]	Margin PK [dB]	Height [cm]	Angle [°]
4924.099	Y/H	59.7	-7.1	52.6	74	21.4	104	95
9847.960	Y/H	54.6	-7.6	47.0	74	27.0	106	205
24062.060	Y/H	53.7	-12.4	41.3	74	32.7	125	338

Note: Level PK = Reading PK + Factor

Table 43: Radiated Emissions at Band Edge, Average and Peak Data, Horizontal and Vertical Antenna Orientations, Modes A (2412MHz) and C (2462MHz), 11g

Operating Frequency [MHz]	EUT / Antenna Orientation	Level AV [dB μ V/m]	Level PK [dB μ V/m]	Limit AV [dB μ V/m]	Limit PK [dB μ V/m]	Margin AV [dB]	Margin PK [dB]
2389.624	Y/H	46.45	-	54	-	7.55	-
2389.688	Y/H	-	59.63	-	74	-	14.37
2483.572	Y/H	48.10	-	54	-	5.90	-
2484.420	Y/H	-	62.25	-	74	-	11.75

Notes: All correction factors (antenna, cable, pre-amplifier) are included in the measurement values.

Average limit in dB μ V/m is calculated as follows: Average limit = 20 x log(500 μ V/m).

Peak limit in dB μ V/m is calculated as follows: Peak limit = Average limit + 20dB.

Figure 70: Radiated Spurious Emissions at Band Edge, Mode A (2412MHz), 11g

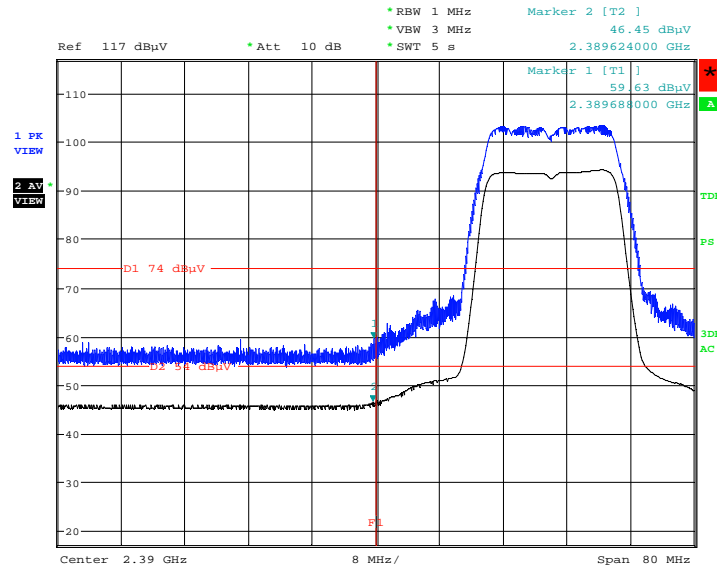

BE, 11g, ModeA, Y, H,150
Date: 26.MAY.2015 20:08:46

Figure 71: Radiated Spurious Emissions at Band Edge, Mode C (2462MHz), 11g

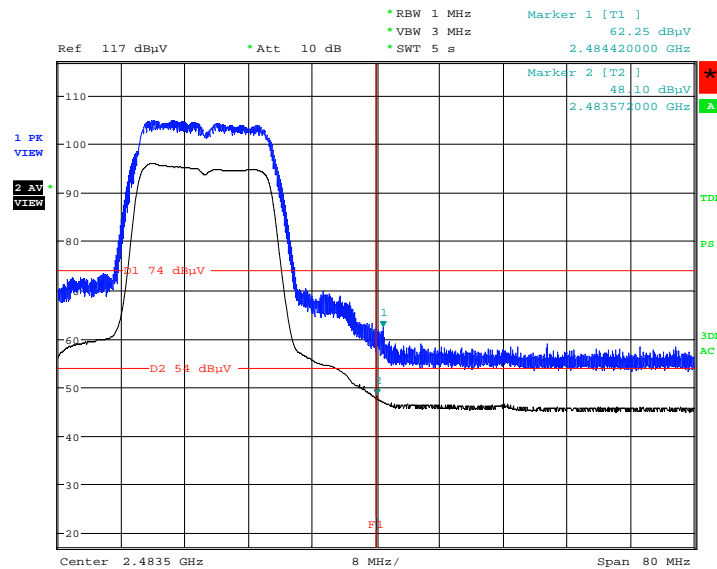

BE, 11g, ModeC, Y, H,150
Date: 26.MAY.2015 20:12:04

Table 44: Radiated Emissions, Average Data, 1 - 25GHz, Horizontal and Vertical Antenna Orientations, Mode A (2412MHz), 11n(20HT)

Freq. [MHz]	EUT / Antenna Orientation	Reading AV [dBµV]	Factor [dB(1/m)]	Level AV [dBµV/m]	Limit [dBµV/m]	Margin AV [dB]	Height [cm]	Angle [°]
4824.893	Y/H	38.4	-7.1	31.3	54	22.7	196	347
9847.961	Y/H	49.1	-7.6	41.5	54	12.5	100	207
23751.132	Y/H	40.1	-12.4	27.7	54	26.3	125	121

Note: Level AV = Reading AV + Factor

Table 45: Radiated Emissions, Peak Data, 1 - 25GHz, Horizontal and Vertical Antenna Orientations, Mode A (2412MHz), 11n(20HT)

Freq. [MHz]	EUT / Antenna Orientation	Reading PK [dBµV]	Factor [dB(1/m)]	Level PK [dBµV/m]	Limit [dBµV/m]	Margin PK [dB]	Height [cm]	Angle [°]
4824.893	Y/H	52.3	-7.1	45.2	74	28.8	196	347
9847.961	Y/H	54.2	-7.6	46.6	74	27.4	100	207
23751.132	Y/H	54.0	-12.4	41.6	74	32.4	125	121

Note: Level PK = Reading PK + Factor

Table 46: Radiated Emissions, Average Data, 1 - 25GHz, Horizontal and Vertical Antenna Orientations, Mode B (2437MHz), 11n(20HT)

Freq. [MHz]	EUT / Antenna Orientation	Reading AV [dBµV]	Factor [dB(1/m)]	Level AV [dBµV/m]	Limit [dBµV/m]	Margin AV [dB]	Height [cm]	Angle [°]
4873.950	Y/H	52.9	-7.2	45.7	54	8.3	54	174
9747.960	Y/H	49.4	-7.8	41.6	54	12.4	155	214

Note: Level AV = Reading AV + Factor

Table 47: Radiated Emissions, Peak Data, 1 - 25GHz, Horizontal and Vertical Antenna Orientations, Mode B (2437MHz), 11n(20HT)

Freq. [MHz]	EUT / Antenna Orientation	Reading PK [dBµV]	Factor [dB(1/m)]	Level PK [dBµV/m]	Limit [dBµV/m]	Margin PK [dB]	Height [cm]	Angle [°]
4873.950	Y/H	57.7	-7.2	50.5	74	23.5	74	174
9747.960	Y/H	55	-7.8	47.2	74	26.8	155	214

Note: Level PK = Reading PK + Factor

Table 48: Radiated Emissions, Average Data, 1 - 25GHz, Horizontal and Vertical Antenna Orientations, Mode C (2462MHz), 11n(20HT)

Freq. [MHz]	EUT / Antenna Orientation	Reading AV [dBµV]	Factor [dB(1/m)]	Level AV [dBµV/m]	Limit [dBµV/m]	Margin AV [dB]	Height [cm]	Angle [°]
4924.241	Y/H	39.6	-7.1	32.5	54	21.5	135	92
9847.961	Y/H	49.1	-7.6	41.5	54	12.5	100	207
20701.660	Y/H	37.6	-10.8	40.6	54	27.2	100	6.2

Note: Level AV = Reading AV + Factor

Table 49: Radiated Emissions, Peak Data, 1 - 25GHz, Horizontal and Vertical Antenna Orientations, Mode C (2462MHz), 11n(20HT)

Freq. [MHz]	EUT / Antenna Orientation	Reading PK [dBµV]	Factor [dB(1/m)]	Level PK [dBµV/m]	Limit [dBµV/m]	Margin PK [dB]	Height [cm]	Angle [°]
4924.241	Y/H	55.3	-7.1	74	74	25.8	135	92
9847.961	Y/H	54.2	-7.6	46.6	74	27.4	100	207
20701.660	Y/H	51.4	-10.8	40.6	74	33.4	100	6.2

Note: Level PK = Reading PK + Factor

Table 50: Radiated Emissions at Band Edge, Average and Peak Data, Horizontal and Vertical Antenna Orientations, Modes A (2412MHz) and C (2462MHz), 11n(20HT)

Operating Frequency [MHz]	EUT / Antenna Orientation	Level AV [dBµV/m]	Level PK [dBµV/m]	Limit AV [dBµV/m]	Limit PK [dBµV/m]	Margin AV [dB]	Margin PK [dB]
2389.880	Y/H	47.37	-	54	-	6.63	-
2389.792	Y/H	-	63.78	-	74	-	10.22
2484.972	Y/H	49.40	-	54	-	4.6 (*)	-
2483.636	Y/H	-	65.19	-	74	-	8.81

Notes: All correction factors (antenna, cable, pre-amplifier) are included in the measurement values.
 Average limit in dBµV/m is calculated as follows: Average limit = 20 x log(500µV/m).
 Peak limit in dBµV/m is calculated as follows: Peak limit = Average limit + 20dB.

(*) The measured result is below the specification limit by a margin less than the measurement uncertainty; it is therefore not possible to determine compliance at a level of confidence of 95%. However, the measured result indicates a high probability that the tested product complies with the specification limit.

Figure 72: Radiated Spurious Emissions at Band Edge, Mode A (2412MHz), 11n(20HT)

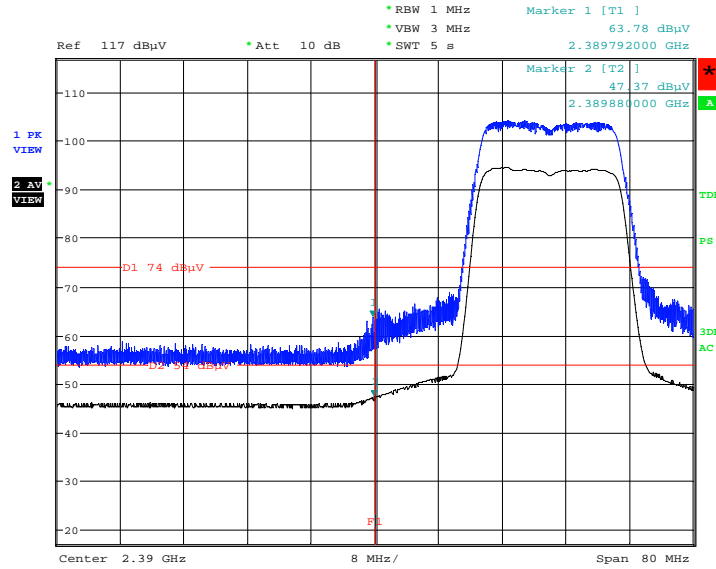

BE, 11n 20, ModeA, Y, H,150
 Date: 26.MAY.2015 20:31:25

Figure 73: Conducted Spurious Emissions at Band Edge, Mode C (2462MHz), 11n(20HT)

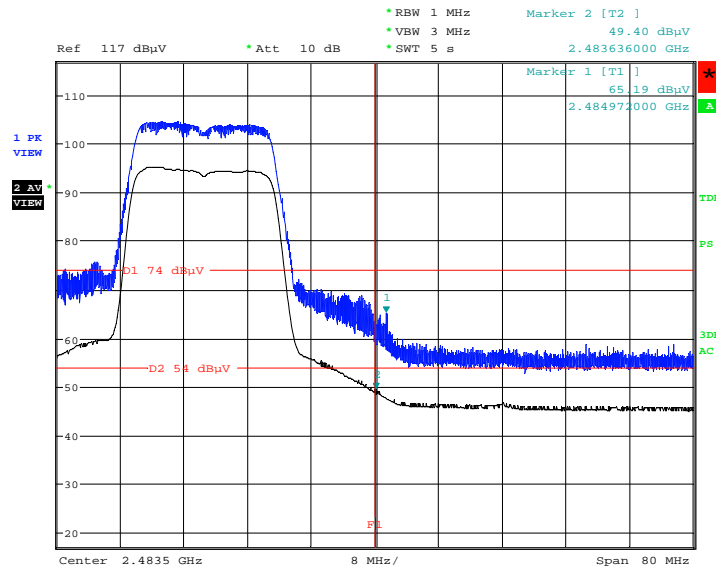

BE, 11n 20, ModeC, Y, H,150
 Date: 26.MAY.2015 20:28:14

Table 51: Radiated Emissions, Average Data, 1 - 25GHz, Horizontal and Vertical Antenna Orientations, Mode A (2422MHz), 11n(40HT)

Freq. [MHz]	EUT / Antenna Orientation	Reading AV [dBµV]	Factor [dB(1/m)]	Level AV [dBµV/m]	Limit [dBµV/m]	Margin AV [dB]	Height [cm]	Angle [°]
4868.084	Y/H	38.1	-6.0	32.1	54	21.9	108	126
7236.000	Y/H	37.8	1.2	39.0	54	15.0	100	222
7326.000	Y/V	37.8	1.5	39.3	54	14.7	100	353
9687.969	Y/H	49.1	-8.3	40.8	54	13.2	106	328
23056.350	Y/V	38.9	-11.8	27.1	54	26.9	100	10

Note: Level AV = Reading AV + Factor

Table 52: Radiated Emissions, Peak Data, 1 - 25GHz, Horizontal and Vertical Antenna Orientations, Mode A (2422MHz), 11n(40HT)

Freq. [MHz]	EUT / Antenna Orientation	Reading PK [dBµV]	Factor [dB(1/m)]	Level PK [dBµV/m]	Limit [dBµV/m]	Margin PK [dB]	Height [cm]	Angle [°]
4868.084	Y/H	52	-6	46	74	28	108	126
7236.000	Y/H	50.8	1.2	52	74	22	100	222
7326.000	Y/V	51.7	1.5	53.2	74	20.8	100	353
9687.969	Y/H	55.2	-8.3	46.9	74	27.1	106	328
23056.350	Y/V	53.1	-11.8	41.3	74	32.7	100	10

Note: Level PK = Reading PK + Factor

Table 53: Radiated Emissions, Average Data, 1 - 25GHz, Horizontal and Vertical Antenna Orientations, Mode B (2447MHz), 11n(40HT)

Freq. [MHz]	EUT / Antenna Orientation	Reading AV [dBµV]	Factor [dB(1/m)]	Level AV [dBµV/m]	Limit [dBµV/m]	Margin AV [dB]	Height [cm]	Angle [°]
4872.980	Y/H	52.8	-7.2	45.6	54	8.4	175	88
9747.540	Y/H	49.2	-7.8	41.4	54	12.6	156	216

Note: Level AV = Reading AV + Factor

Table 54: Radiated Emissions, Peak Data, 1 - 25GHz, Horizontal and Vertical Antenna Orientations, Mode B (2447MHz), 11n(40HT)

Freq. [MHz]	EUT / Antenna Orientation	Reading PK [dBµV]	Factor [dB(1/m)]	Level PK [dBµV/m]	Limit [dBµV/m]	Margin PK [dB]	Height [cm]	Angle [°]
4872.980	Y/H	57.7	-7.2	50.5	74	23.5	175	88
9747.540	Y/H	55.0	-7.8	47.2	74	26.8	156	216

Note: Level PK = Reading PK + Factor

Table 55: Radiated Emissions, Average Data, 1 - 25GHz, Horizontal and Vertical Antenna Orientations, Mode C (2452MHz), 11n(40HT)

Freq. [MHz]	EUT / Antenna Orientation	Reading AV [dBµV]	Factor [dB(1/m)]	Level AV [dBµV/m]	Limit [dBµV/m]	Margin AV [dB]	Height [cm]	Angle [°]
4903.955	Y/H	38.7	-6.1	32.6	54	21.4	100	150
7356.100	Y/H	37.9	1.5	39.4	54	14.6	100	51
9807.970	Y/H	49.1	-7.6	41.5	54	12.5	101	202
23099.262	Y/H	38.9	-11.9	27.0	54	27.0	128	288

Note: Level AV = Reading AV + Factor

Table 56: Radiated Emissions, Peak Data, 1 - 25GHz, Horizontal and Vertical Antenna Orientations, Mode C (2452MHz), 11n(40HT)

Freq. [MHz]	EUT / Antenna Orientation	Reading PK [dBµV]	Factor [dB(1/m)]	Level PK [dBµV/m]	Limit [dBµV/m]	Margin PK [dB]	Height [cm]	Angle [°]
4903.955	Y/H	53.0	-6.1	46.9	74	27.1	100	150
7356.100	Y/H	51.8	1.5	53.3	74	20.7	100	51
9807.970	Y/H	54.2	-7.6	46.6	74	27.4	101	202
23099.262	Y/H	52.7	-11.9	40.8	74	33.2	128	288

Note: Level PK = Reading PK + Factor

Table 57: Radiated Emissions at Band Edge, Average and Peak Data, Horizontal and Vertical Antenna Orientations, Modes A (2422MHz) and C (2452MHz), 11n(40HT)

Operating Frequency [MHz]	EUT / Antenna Orientation	Level AV [dBµV/m]	Level PK [dBµV/m]	Limit AV [dBµV/m]	Limit PK [dBµV/m]	Margin AV [dB]	Margin PK [dB]
2389.920	Y/H	49.44	-	54	-	4.56 (*)	-
2388.784	Y/H	-	63.87	-	74	-	10.13
2488.140	Y/H	50.19	-	54	-	3.81 (*)	-
2483.740	Y/H	-	62.43	-	74	-	11.57

Notes: All correction factors (antenna, cable, pre-amplifier) are included in the measurement values.
 Average limit in dBµV/m is calculated as follows: Average limit = 20 x log(500µV/m).
 Peak limit in dBµV/m is calculated as follows: Peak limit = Average limit + 20dB.

(*) The measured result is below the specification limit by a margin less than the measurement uncertainty; it is therefore not possible to determine compliance at a level of confidence of 95%. However, the measured result indicates a high probability that the tested product complies with the specification limit.

Figure 74: Conducted Spurious Emissions at Band Edge, Mode A (2422MHz), 11n(40HT)

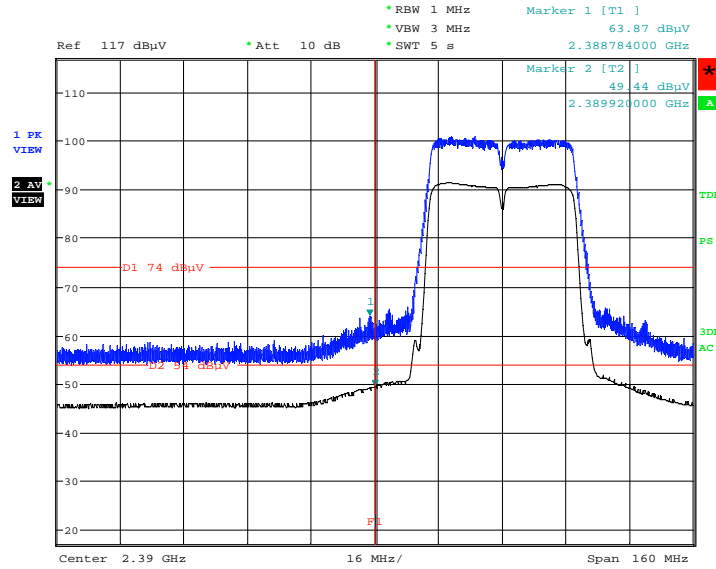

BE, 11n 40, ModeA, Y, H,150
 Date: 26.MAY.2015 21:03:06

Figure 75: Conducted Spurious Emissions at Band Edge, Mode C (2452MHz), 11n(40HT)

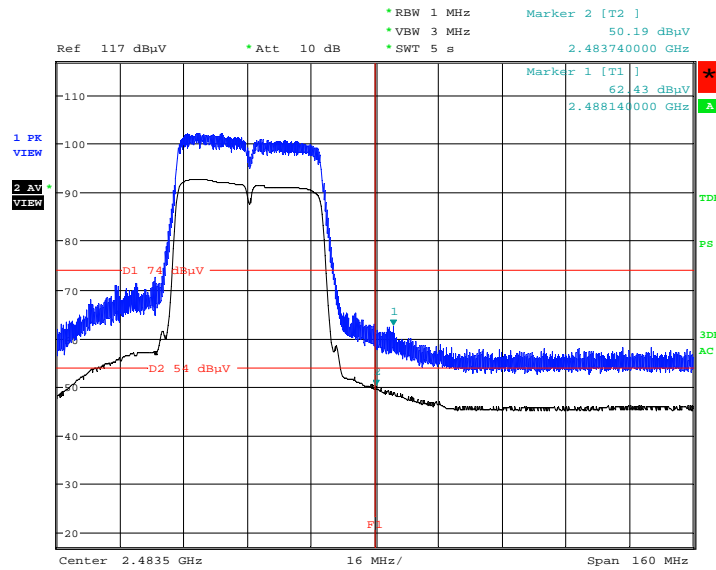

BE, 11n 40, ModeC, Y, H,150
 Date: 26.MAY.2015 21:06:47

Prüfbericht - Nr.: 50027424 001

Seite 110 von 123

Test Report No.:

Page 110 of 123

5.4 AC Power Line Conducted Measurements

5.4.1 AC Power Line Conducted Emission of Transmitter

RESULT:**PASS**

Date of testing: 2015-11-04

Ambient temperature: 22°C

Relative humidity: 40%

Atmospheric pressure: 1029hPa

Frequency range: 0.15 - 30MHz

Kind of test site: Shielded Room

Requirements:

FCC 15.207 and RSS-Gen 8.8

The AC power line conducted emission on any frequency within the band 150kHz to 30MHz shall not exceed the limits specified in FCC 15.207 and RSS-Gen 8.8 (table 3).

Test procedure:

ANSI C63.10-2013 and RSS-Gen 8.1

The EUT was placed on a wooden table raised 80cm above the reference ground plane. A vertical conducting plane of the screened room was located 40cm to the rear of the EUT. The EUT was connected to a Line Impedance Stabilization Network (LISN).

The physical arrangement of the test system and associated cabling was varied to determine the effect on the EUT's emissions in amplitude and frequency in order to ensure that maximum emission amplitudes were attained.

The measurements were performed with a test receiver operating in the CISPR quasi-peak and average detection modes. The receiver's 6dB bandwidth was set to 9kHz.

Disturbances other than those mentioned are small or not detectable.

Prüfbericht - Nr.: 50027424 001

Seite 111 von 123

Test Report No.:

Page 111 of 123

Table 58: AC Power Line Conducted Emission, Quasi Peak and Average Data, 0.15 - 30MHz, Phase N (N) and L1 (L), Mode A (2412MHz), 11b

Freq. [MHz]	Phase	Reading QP [dBµV]	Reading AV [dBµV]	Factor [dB]	Level QP [dBµV]	Level AV [dBµV]	Limit QP [dBµV]	Limit AV [dBµV]	Margin QP [dB]	Margin AV [dB]
0.64911	L1	29.2	13.2	9.6	38.8	22.8	56.0	46.0	17.2	23.2
0.15127	L1	40.5	20.2	9.6	50.1	29.8	65.9	55.9	15.8	26.1
19.45184	N	29.1	23.7	10.1	39.2	33.8	60.0	50.0	20.8	16.2

Note: Level QP = Reading QP + Factor, Level AV = Reading AV + Factor

Table 59: AC Power Line Conducted Emission, Quasi Peak and Average Data, 0.15 - 30MHz, Phase N (N) and L1 (L), Mode B (2437MHz), 11b

Freq. [MHz]	Phase	Reading QP [dBµV]	Reading AV [dBµV]	Factor [dB]	Level QP [dBµV]	Level AV [dBµV]	Limit QP [dBµV]	Limit AV [dBµV]	Margin QP [dB]	Margin AV [dB]
0.15103	L1	40.2	19.9	9.6	49.8	29.5	65.9	55.9	16.1	26.4
0.64852	L1	29.4	13.4	9.6	39.0	23.0	56.0	46.0	17.0	23.0
19.45752	N	28.7	23.2	10.1	38.8	33.3	60.0	50.0	21.2	16.7

Note: Level QP = Reading QP + Factor, Level AV = Reading AV + Factor

Table 60: AC Power Line Conducted Emission, Quasi Peak and Average Data, 0.15 - 30MHz, Phase N (N) and L1 (L), Mode C (2462MHz), 11b

Freq. [MHz]	Phase	Reading QP [dBµV]	Reading AV [dBµV]	Factor [dB]	Level QP [dBµV]	Level AV [dBµV]	Limit QP [dBµV]	Limit AV [dBµV]	Margin QP [dB]	Margin AV [dB]
0.15140	L1	39.9	19.6	9.6	49.5	29.2	65.9	55.9	16.4	26.7
0.64997	L1	29.3	13.0	9.6	38.9	22.6	56.0	46.0	17.1	23.4
20.0378	N	29.4	23.9	10.2	39.6	34.1	60.0	50.0	20.4	15.9

Note: Level QP = Reading QP + Factor, Level AV = Reading AV + Factor

Prüfbericht - Nr.: 50027424 001

Seite 112 von 123

Test Report No.:

Page 112 of 123

Table 61: AC Power Line Conducted Emission, Quasi Peak and Average Data, 0.15 - 30MHz, Phase N (N) and L1 (L), Mode A (2412MHz), 11g

Freq. [MHz]	Phase	Reading QP [dBµV]	Reading AV [dBµV]	Factor [dB]	Level QP [dBµV]	Level AV [dBµV]	Limit QP [dBµV]	Limit AV [dBµV]	Margin QP [dB]	Margin AV [dB]
0.15068	L1	40.1	19.8	9.6	49.7	29.4	66	56	16.3	26.6
0.64437	L1	29.5	12.6	9.6	39.1	22.2	56	46	16.9	23.8
20.04984	N	29.4	23.9	10.2	39.6	34.1	60	50	20.4	15.9

Note: Level QP = Reading QP + Factor, Level AV = Reading AV + Factor

Table 62: AC Power Line Conducted Emission, Quasi Peak and Average Data, 0.15 - 30MHz, Phase N (N) and L1 (L), Mode B (2437MHz), 11g

Freq. [MHz]	Phase	Reading QP [dBµV]	Reading AV [dBµV]	Factor [dB]	Level QP [dBµV]	Level AV [dBµV]	Limit QP [dBµV]	Limit AV [dBµV]	Margin QP [dB]	Margin AV [dB]
0.15050	L1	39.8	19.5	9.6	49.4	29.1	66	56	16.6	26.9
0.64545	L1	29.7	13.0	9.6	39.3	22.6	56	46	16.7	23.4
20.04436	N	30.0	24.4	10.2	40.2	34.6	60	50	19.8	15.4

Note: Level QP = Reading QP + Factor, Level AV = Reading AV + Factor

Table 63: AC Power Line Conducted Emission, Quasi Peak and Average Data, 0.15 - 30MHz, Phase N (N) and L1 (L), Mode C (2462MHz), 11g

Freq. [MHz]	Phase	Reading QP [dBµV]	Reading AV [dBµV]	Factor [dB]	Level QP [dBµV]	Level AV [dBµV]	Limit QP [dBµV]	Limit AV [dBµV]	Margin QP [dB]	Margin AV [dB]
0.15000	L1	40.0	19.6	9.6	49.6	29.2	66	56	16.4	26.8
0.64922	L1	29.5	12.8	9.6	39.1	22.4	56	46	16.9	23.6
20.43404	N	29.6	24.0	10.2	39.8	34.2	60	50	20.2	15.8

Note: Level QP = Reading QP + Factor, Level AV = Reading AV + Factor

Table 64: AC Power Line Conducted Emission, Quasi Peak and Average Data, 0.15 - 30MHz, Phase N (N) and L1 (L), Mode A (2412MHz), 11n(20HT)

Freq. [MHz]	Phase	Reading QP [dBµV]	Reading AV [dBµV]	Factor [dB]	Level QP [dBµV]	Level AV [dBµV]	Limit QP [dBµV]	Limit AV [dBµV]	Margin QP [dB]	Margin AV [dB]
0.15069	L1	39.7	19.3	9.6	49.3	28.9	66	56	16.7	27.1
0.64922	L1	29.5	12.8	9.6	39.1	22.4	56	46	16.9	23.6
20.23796	N	30.2	24.5	10.2	40.4	34.7	60	50	19.6	15.3

Note: Level QP = Reading QP + Factor, Level AV = Reading AV + Factor

Table 65: AC Power Line Conducted Emission, Quasi Peak and Average Data, 0.15 - 30MHz, Phase N (N) and L1 (L), Mode B (2437MHz), 11n(20HT)

Freq. [MHz]	Phase	Reading QP [dBµV]	Reading AV [dBµV]	Factor [dB]	Level QP [dBµV]	Level AV [dBµV]	Limit QP [dBµV]	Limit AV [dBµV]	Margin QP [dB]	Margin AV [dB]
0.15000	L1	40.0	19.6	9.6	49.6	29.2	66	56	16.4	26.8
0.64922	L1	29.5	12.8	9.6	39.1	22.4	56	46	16.9	23.6
20.43404	N	29.6	24.0	10.2	39.8	34.2	60	50	20.2	15.8

Note: Level QP = Reading QP + Factor, Level AV = Reading AV + Factor

Table 66: AC Power Line Conducted Emission, Quasi Peak and Average Data, 0.15 - 30MHz, Phase N (N) and L1 (L), Mode C (2462MHz), 11n(20HT)

Freq. [MHz]	Phase	Reading QP [dBµV]	Reading AV [dBµV]	Factor [dB]	Level QP [dBµV]	Level AV [dBµV]	Limit QP [dBµV]	Limit AV [dBµV]	Margin QP [dB]	Margin AV [dB]
0.15046	L1	39.6	19.3	9.6	49.2	28.9	66	56	16.8	27.1
0.64578	L1	29.7	13.1	9.6	39.3	22.7	56	46	16.7	23.3
19.89848	N	29.7	24.3	10.1	39.8	34.4	60	50	20.2	15.6

Note: Level QP = Reading QP + Factor, Level AV = Reading AV + Factor

Prüfbericht - Nr.: 50027424 001

Seite 114 von 123

Test Report No.:

Page 114 of 123

Table 67: AC Power Line Conducted Emission, Quasi Peak and Average Data, 0.15 - 30MHz, Phase N (N) and L1 (L), Mode A (2422MHz), 11n(40HT)

Freq. [MHz]	Phase	Reading QP [dBμV]	Reading AV [dBμV]	Factor [dB]	Level QP [dBμV]	Level AV [dBμV]	Limit QP [dBμV]	Limit AV [dBμV]	Margin QP [dB]	Margin AV [dB]
0.15236	L1	39.3	18.9	9.6	48.9	28.5	65.9	55.9	17.0	27.4
0.64864	L1	29.6	12.9	9.6	39.2	22.5	56.0	46.0	16.8	23.5
20.14376	N	30.2	24.7	10.2	40.4	34.9	56.0	46.0	19.6	15.1
22.45564	N	27.7	22.4	10.2	37.9	32.6	56.0	46.0	22.1	17.4
26.86748	N	21.2	16.3	10.2	31.4	26.5	56.0	46.0	28.6	23.5
16.65236	N	19.1	12.1	10.1	29.2	22.2	56.0	46.0	30.8	27.8
11.73108	N	17.6	12.4	10.0	27.6	22.4	56.0	46.0	32.4	27.6
0.18893	L1	34.3	12.7	9.6	43.9	22.3	64.1	54.1	20.2	31.8

Note: Level QP = Reading QP + Factor, Level AV = Reading AV + Factor

Table 68: AC Power Line Conducted Emission, Quasi Peak and Average Data, 0.15 - 30MHz, Phase N (N) and L1 (L), Mode B (2447MHz), 11n(40HT)

Freq. [MHz]	Phase	Reading QP [dBμV]	Reading AV [dBμV]	Factor [dB]	Level QP [dBμV]	Level AV [dBμV]	Limit QP [dBμV]	Limit AV [dBμV]	Margin QP [dB]	Margin AV [dB]
0.15810	L1	38.4	17.0	9.6	48.0	26.6	65.6	55.6	17.6	29
0.64297	L1	29.4	12.7	9.6	39.0	22.3	56.0	46.0	17.0	23.7
20.11848	N	30.2	24.6	10.2	40.4	34.8	60.0	50.0	19.6	15.2

Note: Level QP = Reading QP + Factor, Level AV = Reading AV + Factor

Table 69: AC Power Line Conducted Emission, Quasi Peak and Average Data, 0.15 - 30MHz, Phase N (N) and L1 (L), Mode C (2452MHz), 11n(40HT)

Freq. [MHz]	Phase	Reading QP [dBμV]	Reading AV [dBμV]	Factor [dB]	Level QP [dBμV]	Level AV [dBμV]	Limit QP [dBμV]	Limit AV [dBμV]	Margin QP [dB]	Margin AV [dB]
0.15130	L1	39.5	19.1	9.6	49.1	28.7	65.9	55.9	16.8	27.2
0.64804	L1	29.6	13.0	9.6	39.2	22.6	56.0	46.0	16.8	23.4
20.25960	L1	29.9	24.2	10.1	40.0	34.3	60.0	50.0	20.0	15.7

Note: Level QP = Reading QP + Factor, Level AV = Reading AV + Factor

7. List of Tables

Table 1: List of Test and Measurement Equipment	6
Table 2: Emission Measurement Uncertainty	7
Table 3: Interfaces present on the EUT	11
Table 4: Conducted Output Power, 11b_Antenna 0	17
Table 5: Conducted Output Power, 11b_Antenna 1	17
Table 6: Conducted Output Power, 11g_Antenna 0	17
Table 7: Conducted Output Power, 11g_Antenna 1	17
Table 8: Conducted Output Power, 11n(20HT).....	17
Table 9: Conducted Output Power, 11n(40HT).....	18
Table 10: 6dB Bandwidth, 11b_Antenna 0.....	20
Table 11: 6dB Bandwidth, 11g_Antenna 0.....	22
Table 12: 6dB Bandwidth, 11n(20HT)_Antenna 0	24
Table 13: 6dB Bandwidth, 11n(20HT)_Antenna 1	26
Table 14: 6dB Bandwidth, 11n(40HT)_Antenna 0	28
Table 15: 6dB Bandwidth, 11n(40HT)_Antenna 1	30
Table 16: 99% Bandwidth, 11b_Antenna 0.....	33
Table 17: 99% Bandwidth, 11g_Antenna 0.....	35
Table 18: 99% Bandwidth, 11n(20HT)_Antenna 0.....	37
Table 19: 99% Bandwidth, 11n(20HT)_Antenna 1.....	39
Table 20: 99% Bandwidth, 11n(40HT)_Antenna 0.....	41
Table 21: 99% Bandwidth, 11n(40HT)_Antenna 1.....	43
Table 22: Conducted Spurious Emissions in Non-Restricted Frequency Bands	45
Table 23: Peak Power Spectral Density, 11b_Antenna 0	83
Table 24: Peak Power Spectral Density, 11g_Antenna 0	85
Table 25: Peak Power Spectral Density, 11n(20HT)_Antenna 0.....	87
Table 26: Peak Power Spectral Density, 11n(20HT)_Antenna 1.....	89
Table 27: Peak Power Spectral Density, 11n(40HT)_Antenna 0.....	91
Table 28: Peak Power Spectral Density, 11n(40HT)_Antenna 1.....	93
Table 29: Radiated Emissions, Quasi Peak Data, 30MHz - 1GHz, Horizontal and Vertical Antenna Orientations, Mode A (2412MHz), 11b.....	97
Table 30: Radiated Emissions, Average Data, 1 - 25GHz, Horizontal and Vertical Antenna Orientations, Mode A (2412MHz), 11b	98
Table 31: Radiated Emissions, Peak Data, 1 - 25GHz, Horizontal and Vertical Antenna Orientations, Mode A (2412MHz), 11b	98
Table 32: Radiated Emissions, Average Data, 1 - 25GHz, Horizontal and Vertical Antenna Orientations, Mode B (2437MHz), 11b	98
Table 33: Radiated Emissions, Peak Data, 1 - 25GHz, Horizontal and Vertical Antenna Orientations, Mode B (2437MHz), 11b	98
Table 34: Radiated Emissions, Average Data, 1 - 25GHz, Horizontal and Vertical Antenna Orientations, Mode C (2462MHz), 11b	99
Table 35: Radiated Emissions, Peak Data, 1 - 25GHz, Horizontal and Vertical Antenna Orientations, Mode C (2462MHz), 11b	99
Table 36: Radiated Emissions at Band Edge, Average and Peak Data, Horizontal and Vertical Antenna Orientations, Modes A (2412MHz) and C (2462MHz), 11b.....	99
Table 37: Radiated Emissions, Average Data, 1 - 25GHz, Horizontal and Vertical Antenna Orientations, Mode A (2412MHz), 11g	101
Table 38: Radiated Emissions, Peak Data, 1 - 25GHz, Horizontal and Vertical Antenna Orientations, Mode A (2412MHz), 11g	101
Table 39: Radiated Emissions, Average Data, 1 - 25GHz, Horizontal and Vertical Antenna Orientations, Mode B (2437MHz), 11g	101
Table 40: Radiated Emissions, Peak Data, 1 - 25GHz, Horizontal and Vertical Antenna Orientations, Mode B (2437MHz), 11g	101
Table 41: Radiated Emissions, Average Data, 1 - 25GHz, Horizontal and Vertical Antenna Orientations, Mode C (2462MHz), 11g	102

Prüfbericht - Nr.: 50027424 001

Seite 121 von 123

Test Report No.:

Page 121 of 123

Table 42: Radiated Emissions, Peak Data, 1 - 25GHz, Horizontal and Vertical Antenna Orientations, Mode C (2462MHz), 11g	102
Table 43: Radiated Emissions at Band Edge, Average and Peak Data, Horizontal and Vertical Antenna Orientations, Modes A (2412MHz) and C (2462MHz), 11g	102
Table 44: Radiated Emissions, Average Data, 1 - 25GHz, Horizontal and Vertical Antenna Orientations, Mode A (2412MHz), 11n(20HT)	104
Table 45: Radiated Emissions, Peak Data, 1 - 25GHz, Horizontal and Vertical Antenna Orientations, Mode A (2412MHz), 11n(20HT)	104
Table 46: Radiated Emissions, Average Data, 1 - 25GHz, Horizontal and Vertical Antenna Orientations, Mode B (2437MHz), 11n(20HT)	104
Table 47: Radiated Emissions, Peak Data, 1 - 25GHz, Horizontal and Vertical Antenna Orientations, Mode B (2437MHz), 11n(20HT)	104
Table 48: Radiated Emissions, Average Data, 1 - 25GHz, Horizontal and Vertical Antenna Orientations, Mode C (2462MHz), 11n(20HT)	105
Table 49: Radiated Emissions, Peak Data, 1 - 25GHz, Horizontal and Vertical Antenna Orientations, Mode C (2462MHz), 11n(20HT)	105
Table 50: Radiated Emissions at Band Edge, Average and Peak Data, Horizontal and Vertical Antenna Orientations, Modes A (2412MHz) and C (2462MHz), 11n(20HT)	105
Table 51: Radiated Emissions, Average Data, 1 - 25GHz, Horizontal and Vertical Antenna Orientations, Mode A (2422MHz), 11n(40HT)	107
Table 52: Radiated Emissions, Peak Data, 1 - 25GHz, Horizontal and Vertical Antenna Orientations, Mode A (2422MHz), 11n(40HT)	107
Table 53: Radiated Emissions, Average Data, 1 - 25GHz, Horizontal and Vertical Antenna Orientations, Mode B (2447MHz), 11n(40HT)	107
Table 54: Radiated Emissions, Peak Data, 1 - 25GHz, Horizontal and Vertical Antenna Orientations, Mode B (2447MHz), 11n(40HT)	107
Table 55: Radiated Emissions, Average Data, 1 - 25GHz, Horizontal and Vertical Antenna Orientations, Mode C (2452MHz), 11n(40HT)	108
Table 56: Radiated Emissions, Peak Data, 1 - 25GHz, Horizontal and Vertical Antenna Orientations, Mode C (2452MHz), 11n(40HT)	108
Table 57: Radiated Emissions at Band Edge, Average and Peak Data, Horizontal and Vertical Antenna Orientations, Modes A (2422MHz) and C (2452MHz), 11n(40HT)	108
Table 58: AC Power Line Conducted Emission, Quasi Peak and Average Data, 0.15 - 30MHz, Phase N (N) and L1 (L), Mode A (2412MHz), 11b	111
Table 59: AC Power Line Conducted Emission, Quasi Peak and Average Data, 0.15 - 30MHz, Phase N (N) and L1 (L), Mode B (2437MHz), 11b	111
Table 60: AC Power Line Conducted Emission, Quasi Peak and Average Data, 0.15 - 30MHz, Phase N (N) and L1 (L), Mode C (2462MHz), 11b	111
Table 61: AC Power Line Conducted Emission, Quasi Peak and Average Data, 0.15 - 30MHz, Phase N (N) and L1 (L), Mode A (2412MHz), 11g	112
Table 62: AC Power Line Conducted Emission, Quasi Peak and Average Data, 0.15 - 30MHz, Phase N (N) and L1 (L), Mode B (2437MHz), 11g	112
Table 63: AC Power Line Conducted Emission, Quasi Peak and Average Data, 0.15 - 30MHz, Phase N (N) and L1 (L), Mode C (2462MHz), 11g	112
Table 64: AC Power Line Conducted Emission, Quasi Peak and Average Data, 0.15 - 30MHz, Phase N (N) and L1 (L), Mode A (2412MHz), 11n(20HT)	113
Table 65: AC Power Line Conducted Emission, Quasi Peak and Average Data, 0.15 - 30MHz, Phase N (N) and L1 (L), Mode B (2437MHz), 11n(20HT)	113
Table 66: AC Power Line Conducted Emission, Quasi Peak and Average Data, 0.15 - 30MHz, Phase N (N) and L1 (L), Mode C (2462MHz), 11n(20HT)	113
Table 67: AC Power Line Conducted Emission, Quasi Peak and Average Data, 0.15 - 30MHz, Phase N (N) and L1 (L), Mode A (2422MHz), 11n(40HT)	114
Table 68: AC Power Line Conducted Emission, Quasi Peak and Average Data, 0.15 - 30MHz, Phase N (N) and L1 (L), Mode B (2447MHz), 11n(40HT)	114
Table 69: AC Power Line Conducted Emission, Quasi Peak and Average Data, 0.15 - 30MHz, Phase N (N) and L1 (L), Mode C (2452MHz), 11n(40HT)	114

8. List of Figures

Figure 1: Block Diagram.....	11
Figure 2: 6dB Bandwidth, Mode A (2412MHz), 11b_Antenna 0.....	20
Figure 3: 6dB Bandwidth, Mode B (2437MHz), 11b_Antenna 0.....	21
Figure 4: 6dB Bandwidth, Mode C (2462MHz), 11b_Antenna 0.....	21
Figure 5: 6dB Bandwidth, Mode A (2412MHz), 11g_Antenna 0.....	22
Figure 6: 6dB Bandwidth, Mode B (2437MHz), 11g_Antenna 0.....	23
Figure 7: 6dB Bandwidth, Mode C (2462MHz), 11g_Antenna 0.....	23
Figure 8: 6dB Bandwidth, Mode A (2412MHz), 11n(20HT)_Antenna 0.....	24
Figure 9: 6dB Bandwidth, Mode B (2437MHz), 11n(20HT)_Antenna 0.....	25
Figure 10: 6dB Bandwidth, Mode C (2462MHz), 11n(20HT)_Antenna 0.....	25
Figure 11: 6dB Bandwidth, Mode A (2412MHz), 11n(20HT)_Antenna 1.....	26
Figure 12: 6dB Bandwidth, Mode B (2437MHz), 11n(20HT)_Antenna 1.....	27
Figure 13: 6dB Bandwidth, Mode C (2462MHz), 11n(20HT)_Antenna 1.....	27
Figure 14: 6dB Bandwidth, Mode A (2422MHz), 11n(40HT)_Antenna 0.....	28
Figure 15: 6dB Bandwidth, Mode B (2447MHz), 11n(40HT)_Antenna 0.....	29
Figure 16: 6dB Bandwidth, Mode C (2452MHz), 11n(40HT)_Antenna 0.....	29
Figure 17: 6dB Bandwidth, Mode A (2422MHz), 11n(40HT)_Antenna 1.....	30
Figure 18: 6dB Bandwidth, Mode B (2447MHz), 11n(40HT)_Antenna 1.....	31
Figure 19: 6dB Bandwidth, Mode C (2452MHz), 11n(40HT)_Antenna 1.....	31
Figure 20: 99% Bandwidth, Mode A (2412MHz), 11b_Antenna 0.....	33
Figure 21: 99% Bandwidth, Mode B (2437MHz), 11b_Antenna 0.....	34
Figure 22: 99% Bandwidth, Mode C (2462MHz), 11b_Antenna 0.....	34
Figure 23: 99% Bandwidth, Mode A (2412MHz), 11g_Antenna 0.....	35
Figure 24: 99% Bandwidth, Mode B (2437MHz), 11g_Antenna 0.....	36
Figure 25: 99% Bandwidth, Mode C (2462MHz), 11g_Antenna 0.....	36
Figure 26: 99% Bandwidth, Mode A (2412MHz), 11n(20HT)_Antenna 0.....	37
Figure 27: 99% Bandwidth, Mode B (2437MHz), 11n(20HT)_Antenna 0.....	38
Figure 28: 99% Bandwidth, Mode C (2462MHz), 11n(20HT)_Antenna 0.....	38
Figure 29: 99% Bandwidth, Mode A (2412MHz), 11n(20HT)_Antenna 1.....	39
Figure 30: 99% Bandwidth, Mode B (2437MHz), 11n(20HT)_Antenna 1.....	40
Figure 31: 99% Bandwidth, Mode C (2462MHz), 11n(20HT)_Antenna 1.....	40
Figure 32: 99% Bandwidth, Mode A (2422MHz), 11n(40HT)_Antenna 0.....	41
Figure 33: 99% Bandwidth, Mode B (2447MHz), 11n(40HT)_Antenna 0.....	42
Figure 34: 99% Bandwidth, Mode C (2452MHz), 11n(40HT)_Antenna 0.....	42
Figure 35: 99% Bandwidth, Mode A (2422MHz), 11n(40HT)_Antenna 1.....	43
Figure 36: 99% Bandwidth, Mode B (2447MHz), 11n(40HT)_Antenna 1.....	44
Figure 37: 99% Bandwidth, Mode C (2452MHz), 11n(40HT)_Antenna 1.....	44
Figure 38: Conducted Spurious Emissions in Non-Restricted Frequency Bands, 30MHz - 25GHz, Mode A (2412MHz), 11b_Antenna 0.....	46
Figure 39: Conducted Spurious Emissions in Non-Restricted Frequency Bands, 30MHz - 25GHz, Mode B (2437MHz), 11b_Antenna 0.....	49
Figure 40: Conducted Spurious Emissions in Non-Restricted Frequency Bands, 30MHz - 25GHz, Mode C (2462MHz), 11b_Antenna 0.....	52
Figure 41: Conducted Spurious Emissions in Non-Restricted Frequency Bands, 30MHz - 25GHz, Mode A (2412MHz), 11g_Antenna 0.....	55
Figure 42: Conducted Spurious Emissions in Non-Restricted Frequency Bands, 30MHz - 25GHz, Mode B (2437MHz), 11g_Antenna 0.....	58
Figure 43: Conducted Spurious Emissions in Non-Restricted Frequency Bands, 30MHz - 25GHz, Mode C (2462MHz), 11g_Antenna 0.....	61
Figure 44: Conducted Spurious Emissions in Non-Restricted Frequency Bands, 30MHz - 25GHz, Mode A (2412MHz), 11n(20HT)_Antenna 0.....	64
Figure 45: Conducted Spurious Emissions in Non-Restricted Frequency Bands, 30MHz - 25GHz, Mode B (2462MHz), 11n(20HT)_Antenna 0.....	67

Figure 46: Conducted Spurious Emissions in Non-Restricted Frequency Bands, 30MHz - 25GHz, Mode C (2462MHz), 11n(20HT)_Antenna 0	70
Figure 47: Conducted Spurious Emissions in Non-Restricted Frequency Bands, 30MHz - 25GHz, Mode A (2422MHz), 11n(40HT)_Antenna 0	73
Figure 48: Conducted Spurious Emissions in Non-Restricted Frequency Bands, 30MHz - 25GHz, Mode B (2437MHz), 11n(40HT)_Antenna 0	76
Figure 49: Conducted Spurious Emissions in Non-Restricted Frequency Bands, 30MHz - 25GHz, Mode C (2452MHz), 11n(40HT)_Antenna 0	79
Figure 50: Power Spectral Density, Mode A (2412MHz), 11b_Antenna 0.....	83
Figure 51: Power Spectral Density, Mode B (2437MHz), 11b_Antenna 0.....	84
Figure 52: Power Spectral Density, Mode C (2462MHz), 11b_Antenna 0.....	84
Figure 53: Power Spectral Density, Mode A (2412MHz), 11g_Antenna 0.....	85
Figure 54: Power Spectral Density, Mode B (2437MHz), 11g_Antenna 0.....	86
Figure 55: Power Spectral Density, Mode C (2462MHz), 11g_Antenna 0.....	86
Figure 56: Power Spectral Density, Mode A (2412MHz), 11n(20HT)_Antenna 0	87
Figure 57: Power Spectral Density, Mode B (2437MHz), 11n(20HT)_Antenna 0	88
Figure 58: Power Spectral Density, Mode C (2462MHz), 11n(20HT)_Antenna 0	88
Figure 59: Power Spectral Density, Mode A (2412MHz), 11n(20HT)_Antenna 1	89
Figure 60: Power Spectral Density, Mode B (2437MHz), 11n(20HT)_Antenna 1	90
Figure 61: Power Spectral Density, Mode C (2462MHz), 11n(20HT)_Antenna 1	90
Figure 62: Power Spectral Density, Mode A (2422MHz), 11n(40HT)_Antenna 0	91
Figure 63: Power Spectral Density, Mode B (2447MHz), 11n(40HT)_Antenna 0	92
Figure 64: Power Spectral Density, Mode C (2452MHz), 11n(40HT)_Antenna 0	92
Figure 65: Power Spectral Density, Mode A (2422MHz), 11n(40HT)_Antenna 1	93
Figure 66: Power Spectral Density, Mode B (2447MHz), 11n(40HT)_Antenna 1	94
Figure 67: Power Spectral Density, Mode C (2452MHz), 11n(40HT)_Antenna 1	94
Figure 68: Radiated Spurious Emissions at Band Edge, Mode A (2412MHz), 11b.....	100
Figure 69: Radiated Spurious Emissions at Band Edge, Mode C (2462MHz), 11b	100
Figure 70: Radiated Spurious Emissions at Band Edge, Mode A (2412MHz), 11g.....	103
Figure 71: Radiated Spurious Emissions at Band Edge, Mode C (2462MHz), 11g	103
Figure 72: Radiated Spurious Emissions at Band Edge, Mode A (2412MHz), 11n(20HT)	106
Figure 73: Conducted Spurious Emissions at Band Edge, Mode C (2462MHz), 11n(20HT)	106
Figure 74: Conducted Spurious Emissions at Band Edge, Mode A (2422MHz), 11n(40HT)	109
Figure 75: Conducted Spurious Emissions at Band Edge, Mode C (2452MHz), 11n(40HT)	109

9. List of Photographs

Photograph 1: Set-up for Conducted Emissions at Antenna Port.....	115
Photograph 2: Set-up for Radiated Emission, below 1GHz, EUT Configuration Y-Axis, Front View	116
Photograph 3: Set-up for Radiated Emission, below 1GHz, EUT Configuration Y-Axis of Transmitter, Rear View	116
Photograph 4: Set-up for Radiated Emission, Above 1GHz, EUT Configuration Y-Axis, Front View.....	117
Photograph 5: Set-up for Radiated Emission, Above 1GHz, EUT Configuration Y-Axis of Transmitter, Rear View	117
Photograph 6: Set-up for Radiated Emission, EUT Configuration X-Axis.....	118
Photograph 7: Set-up for Radiated Emission, EUT Configuration Y-Axis.....	118
Photograph 8: Set-up for AC Power Line Conducted Emission of Transmitter, Front View	119
Photograph 9: Set-up for AC Power Line Conducted Emission of Transmitter, Rear View.....	119