



Issue Date : January 10, 2006

Page 1 of 42

EMC EMISSION - TEST REPORT

JQA APPLICATION No. : KL80050542R

Name of Product : Facsimile with 2.4GHz FHSS Cordeless Telephone (Base Unit)

Model/Type No. : KX-FG2451

FCC ID : ACJ96NKX-FG2451

Applicant : Panasonic Communications Co., Ltd.

Address : 1-62, 4-chome, Minoshima, Hakata-ku, Fukuoka 812-8531, Japan

Manufacturer : Panasonic Communications Co., Ltd.

Address : 1-62, 4-chome, Minoshima, Hakata-ku, Fukuoka 812-8531, Japan

Receive date of EUT : December 12, 2005

Final Judgement : **Passed**

TEST RESULTS IN THIS REPORT are obtained in use of equipment that is traceable to National Institute of Advanced Industrial Science and Technology (AIST) under METI Japan and National Institute of Information and Communications Technology(NICT) under MPHPT Japan.

THE TEST RESULTS only responds to the test sample. This test report shall not be reproduced except in full.

Authorized by:

Yuichi Fukumoto, Manager
JQA KITA-KANSAI Testing Center

DIRECTORY

	Page
A) Documentation	
Directory	<u>2</u>
Test Regulation / General Information	<u>3 - 5</u>
Test Conditions	<u>6 - 16</u>
Configuration of EUT / Operation mode of the EUT	<u>17 - 18</u>
EUT Modification / Responsible Party / Deviation from Standard	<u>19</u>
Test results / Measurement Uncertainty	<u>20 - 22</u>
Summary	<u>23</u>
Test System-Arrangement (Drawings)	<u>24</u>
Preliminary Test and Test-setup (Drawings)	<u>25 - 28</u>
Test-setup (Photographs) at worst case	<u>29</u>
B) Test data	
AC Powerconducted Emission	150 kHz - 30 MHz <u>30</u>
Electromagnetic Field Radiated Emission	9 kHz - 25 GHz <u>31 - 34</u>
Transmitter Power (EIRP)	<u>35</u>
Transmitter Power (TP)	<u>36</u>
Antenna Gain of the EUT	<u>37</u>
20dB Bandwidth	<u>38</u>
Band-edge Emission	<u>39</u>
Carrier Frequencies Separation	<u>40</u>
Channel Separation / Dwell Time	<u>41 - 42</u>

TEST REGULATION

FCC Rules and Regulations Part 15 Subpart A and C

- Class A Digital Device
- Class B Digital Device
- Intentional Radiator (Sec.15.247)
- Receiver

Test items:

- Sec.15.203 : Antenna requirement
- Sec.15.205 : Restricted bands of operation
- Sec.15.207 : Conducted limits
- Sec.15.209 : Radiated emission limits general requirements
- Sec.15.214 : Cordless Telephones
- Sec.15.247 : Operation within the bands 902-928MHz, 2400-2483.5MHz, 5725-5875MHz, and 24.0-24.25GHz

Test procedure:

The tests were performed according to the procedures in ANSI C63.4-2003.

GENERAL INFORMATION

Test facility:

- 1) Test Facility located at Kita-Kansai : 1st Open Site (3 m Site)
Test Facility located at Kameoka : 1st Open Site (3, 10 and 30 m, on common plane)
: 2nd Open Site (3 and 10 m, on common plane)

FCC filing No. : 31040/SIT 1300F2

- 2) KITA-KANSAI TESTING CENTER is recognized under the National Voluntary Laboratory Accreditation Program for satisfactory compliance established in Title 15, Part 285 Code of Federal Regulations.

NVLAP Lab Code: 200191-0

- 3) Average Measurement Method
FCC filing No. : 950523A 1300F2

Definitions for symbols used in this test report:

- Black box indicates that the listed condition, standard or equipment is applicable for this Report.
- Blank box indicates that the listed condition, standard or equipment is not applicable for this Report.

Description of the Equipment Under Test (EUT):

- 1) Name : Facsimile with 2,4GHz FHSS Cordless Telephone (Base Unit)
- 2) Model/Type No. : KX-FG2451
- 3) Product Type : Prototype
- 4) Category : Intentional Radiator
- 5) EUT Authorization : ○ - Verification ● - Certification ○ - D.o.C.
- 6) Transmitting Frequency : 2400.914355 MHz (01ch) - 2480.292773 MHz (90ch)
- 7) Receiving Frequency : 2400.914355 MHz (01ch) - 2480.292773 MHz (90ch)
- 8) Method/System : Frequency Hopping Spread Spectrum (FHSS)
- 9) Type of Antenna : Dipole Antenna
- 10) Antenna Gain : 2 dBi(Rated)
- 11) Measured MAX Output Power : 66.1 mW (Conducted)
- 12) Power Rating : AC 120V 60Hz 1φ 3-pin plug

Detailed Transmitter portion (Channel plan):

Transmitting frequency : 2400.914355 MHz (01ch) - 2480.292773 MHz (90ch)
 Number of channel : 90

CH	0	1	2	3	4	5	6	7	8	9
0	--	2400.914355	2401.808203	2402.698096	2403.591943	2404.481836	2405.375684	2406.265576	2407.159424	2408.049316
10	2408.943164	2409.833057	2410.726904	2411.616797	2412.510645	2413.400537	2414.294385	2415.184277	2416.078125	2416.968018
20	2417.861865	2418.753736	2419.645935	2420.537806	2421.429677	2422.321548	2423.213419	2424.105290	2424.997161	2425.889032
30	2426.780566	2427.670459	2428.564307	2429.454199	2430.348047	2431.237939	2432.131787	2433.021680	2433.915527	2434.805420
40	2435.699268	2436.589160	2437.483008	2438.372900	2439.266748	2440.156641	2441.050488	2441.940381	2442.834229	2443.724121
50	2444.617969	2445.507861	2446.401709	2447.291602	2448.185449	2449.075342	2449.969189	2450.859082	2451.752930	2452.642822
60	2453.536670	2454.426563	2455.320410	2456.210303	2457.104150	2457.994043	2458.887891	2459.777783	2460.671631	2461.561523
70	2462.455371	2463.345264	2464.239111	2465.129004	2466.022852	2466.912744	2467.806592	2468.696484	2469.590332	2470.480225
80	2471.374072	2472.263965	2473.157813	2474.047705	2474.941553	2475.831445	2476.725293	2477.615186	2478.509033	2479.398926
90	2480.292773	--	--	--	--	--	--	--	--	--

Channel Separation : 891.871 kHz

Modulation System Information:

Spread Spectrum Method : Frequency Hopping
 Modulation : GFSK (Gaussian-shaped Binary Frequency Shift Keying)
 Hop Rate : 100 hops/sec.
 Bit Rate : 576 kBit/sec.
 Digital Security Code : 40 Bit

Time Division Multiple Access(TDMA) Frame structure.

The basic, repeating, frame structure is 10msec long. It is sub-divided into 8 slots, each 1250usec long. The active transmission time is 986.1usec. The first 4 slots from the “up-link” , when the Handsets transmit to the Base Unit. The last 4 slots form the “down-link” , when the Basetset transmits to the Handsets.

This system uses TDD (Time Division Duplex) to carry a two-way voice communication. This is always by using slot-pairs: 0 and 4, 1 and 5, 2 and 6, 3 and 7.

Each slot contains 568 bits of 1.736 usec duration, with 263.9 usec gap times between each slot.

Detailed Receiver portion:

Receiving frequency : 2400.914355 MHz (01ch) - 2480.292773 MHz (90ch)
 Local frequency : 2398.914355 MHz (01ch) - 2478.292773 MHz (90ch)
 Intermediate frequency : 2.000 MHz

Other used (generated) frequencies in the EUT:

Reference Clock : 13.824 MHz
 PLL1(2nd, Reference Clock) : 129.6 MHz

TEST CONDITIONS

AC Powerline Conducted Emission Measurement (Sec.15.207(a))
was performed in the following test site.

Test location:

KITA-KANSAI Testing Center

7-7, Ishimaru, 1-Chome, Mino-Shi, Osaka, 562-0027, Japan

● - Shielded room

KAMEOKA EMC Branch

9-1, Ozaki, Inukanno, Nishibetsuin-Cho, Kameoka-Shi, Kyoto, 621-0126, Japan

○ - Shielded room

○ - On metal plane of open site

Used test instruments and sites:

Type	Model No.	Device ID	Manufacturer	Last Cal. Date	Cal. Interval
● -Receiver	ESCS30	A - 1	Rohde&Schwarz	August, 2005	1 Year
○ -Receiver	ESH2	A - 2	Rohde&Schwarz		
○ -Receiver	ESH2	A - 3	Rohde&Schwarz		
● -LISN	KNW-407	D - 6	Kyoritsu	October, 2005	1 Year
○ -LISN	KNW-408	D - 11	Kyoritsu		
○ -LISN	KNW-242	D - 7	Kyoritsu		
○ -LISN	ESH3-Z5	D - 12	Kyoritsu		
○ -LISN	KNW-341C	D - 13	Kyoritsu		
○ -LISN	KNW-408	D - 14	Kyoritsu		
○ -LISN	KNW-244C	D - 77	Kyoritsu		
○ -LISN	KNW-408	D - 78	Kyoritsu		
○ -LISN	ESH2-Z5	D - 10	Kyoritsu		
○ -High Imp. Probe	ESH2-Z3	D - 17	Kyoritsu		
○ -50Ω Terminator	65 BNC-50-0-1	H - 26	HUBER+SUHNER		
○ -50Ω Terminator	65 BNC-50-0-1	H - 27	HUBER+SUHNER		
○ -Cable	--	H - 7	--		
● -Cable	--	H - 8	--	October, 2005	1 Year

Environmental conditions:

Temperature: 22 °C Humidity: 32 %

Magnetic Field Radiated Emission Measurement (Sec.15.247(d),15.205(a),15.209(a))

was performed in the frequency range of 9 kHz - 30 MHz, in the following test site.

Test location:

KITA-KANSAI Testing Center

7-7, Ishimaru, 1-Chome, Mino-Shi, Osaka, 562-0027, Japan

● - 1st open test site (3 meters)

KAMEOKA EMC Branch

9-1, Ozaki, Inukanno, Nishibetsuin-Cho, Kameoka-Shi, Kyoto, 621-0126, Japan

○ - 1st open test site ○ - 3 m ○ - 10 m ○ - 30 m
○ - 2nd open test site ○ - 3 m ○ - 10 m

Used test instruments:

Type	Model No.	Device ID	Manufacturer	Last Cal. Date	Cal. Interval
● -Reciver	ESCS 30	A - 1	Rohde&Schwarz	August, 2005	1 Year
○ -Reciver	ESH 2	A - 2	Rohde&Schwarz		
○ -Reciver	ESH 2	A - 3	Rohde&Schwarz		
● -Loop Ant.	HFH2-Z2	C - 2	Rohde&Schwarz	August, 2005	1 Year
○ -Loop Ant.	HFH2-Z2	C - 3	Rohde&Schwarz		
● -Cable	RG213/U	H - 28	Rohde&Schwarz	August, 2005	1 Year
○ -Cable	RG213/U	H - 29	Rohde&Schwarz		

Environmental conditions:

Temperature: 26 °C Humidity: 32 %

Electromagnetic Field Radiated Emission Measurement (Sec.15.247(d),15.205(a),15.209(a))

was performed in horizontal and vertical polarization, in the frequency range of 30 MHz - 1000 MHz, in the following test site.

Test location:

KITA-KANSAI Testing Center

7-7, Ishimaru, 1-Chome, Mino-Shi, Osaka, 562-0027, Japan

● - 1st open test site (3 meters)

KAMEOKA EMC Branch

9-1, Ozaki, Inukanno, Nishibetsuin-Cho, Kameoka-Shi, Kyoto, 621-0126, Japan

○ - 1st open test site ○ - 3 m ○ - 10 m ○ - 30 m

○ - 2nd open test site ○ - 3 m ○ - 10 m

Validation of Site Attenuation:

1) Last Confirmed Date : October 3, 2005

2) Interval : 1 Year

Used test instruments:

Type	Model No.	Device ID	Manufacturer	Last Cal. Date	Cal. Interval
○ -Reciver/Pre. Amp.	ESV/ESV-Z3	A - 7 / A - 17	Rohde&Schwarz		
● -Reciver/Pre. Amp.	ESV/ESV-Z3	A - 6 / A - 20	Rohde&Schwarz	June, 2005	1 Year
○ -Reciver/Pre. Amp.	ESV/ESV-Z3	A - 4 / A - 18	Rohde&Schwarz		
○ -Reciver/Pre. Amp.	ESV/ESV-Z3	A - 8 / A - 19	Rohde&Schwarz		
○ -Reciver	ESVS 10	A - 5	Rohde&Schwarz		
○ -Dipole Ant.	KBA-511A	C - 11	Kyoritsu		
○ -Dipole Ant.	KBA-611	C - 21	Kyoritsu		
● -Biconical Ant.	VHA9103/BBA9106	C - 43	Schwarzbeck	August, 2005	1 Year
● -Logperiodic Ant.	UHALP9107	C - 42	Schwarzbeck	August, 2005	1 Year
○ -Biconical Ant.	VHA9103/FBAB9177	C - 25	Schwarzbeck		
○ -Logperiodic Ant.	UHALP9108-A1	C - 28	Schwarzbeck		
● -Cable	---	H - 5	---	August, 20045	1 Year

Environmental conditions:Temperature: 20 °C Humidity: 26 %

Electromagnetic Field Radiated Emission Measurement (Sec.15.247(d),15.205(a),15.209(a))
 was performed in horizontal and vertical polarization, in the frequency range of 1 GHz - 25 GHz,
 in the following test site.

Test location:

KITA-KANSAI Testing Center

7-7, Ishimaru, 1-Chome, Mino-Shi, Osaka, 562-0027, Japan

● - 1st open test site (3 meters)

KAMEOKA EMC Branch

9-1, Ozaki, Inukanno, Nishibetsuin-Cho, Kameoka-Shi, Kyoto, 621-0126, Japan

○ - 1st open test site ○ - 3 m ○ - 10 m ○ - 30 m

○ - 2nd open test site ○ - 3 m ○ - 10 m

Used test instruments:

Type	Model No.	Device ID	Manufacturer	Last Cal. Date	Cal. Interval
○ -Receiver	ESCS30	A - 1	Rohde&Schwarz		
○ -SpectrumAnalyzer	8566B	A - 13	Agilent		
○ -SpectrumAnalyzer	8593A	A - 15	Agilent		
● -SpectrumAnalyzer	4446A	A - 39	Agilent	October, 2005	1 Year
● -Receiver	ESV	A - 7	Rohde&Schwarz	November, 2005	1 Year
○ -10dB Att.	4T-10	D - 73	Lucas Weinschel		
○ -10dB Att.	4T-10	D - 74	Lucas Weinschel		
● -10dB Att.	54-10	D - 82	Lucas Weinschel	May, 2005	1 Year
● -10dB Att.	54-10	D - 83	Lucas Weinschel	May, 2005	1 Year
● -Pre Amp.	WJ-6611-513	A - 23	Watkins Johnson	May, 2005	1 Year
● -Pre Amp.	WJ-6882-824	A - 21	Watkins Johnson	May, 2005	1 Year
● -Pre Amp.	DBL-0618N515	A - 33	DBS Microwave	May, 2005	1 Year
● -Pre Amp.	ALN-22093545-01	A - 37	Wise Wave Technologies	February, 2005	1 Year
○ -Pre Amp.	ALN-33144045-01	A - 38	Wise Wave Technologies		
● -Horn Ant.	91888-2	C - 41 - 1	EATON	May, 2005	1 Year
● -Horn Ant.	91889-2	C - 41 - 2	EATON	May, 2005	1 Year
● -Horn Ant.	94613-1	C - 41 - 3	EATON	May, 2005	1 Year
● -Horn Ant.	91891-2	C - 41 - 4	EATON	May, 2005	1 Year
● -Horn Ant.	94614-1	C - 41 - 5	EATON	May, 2005	1 Year
● -Horn Ant.	3160-09	C - 48	EMCO	December, 2005	2 Years
● -Step Att.	355C	D - 22	Agilent	March, 2005	1 Year
● -Step Att.	355D	D - 23	Agilent	March, 2005	1 Year
○ -Mixer.	MZ5010C	D - 81	Watkins Johnson		1 Year
○ -Signal Generator	8673D	B - 2	Agilent		1 Year
● -Cable	--	C - 40 - 11	HUBER+SUHNER	May, 2005	1 Year
● -Cable	--	C - 40 - 12	HUBER+SUHNER	May, 2005	1 Year
● -Cable	--	C - 53	HUBER+SUHNER	February, 2005	1 Year
● -Cable	--	C - 54	HUBER+SUHNER	February, 2005	1 Year
● -Band Rejection Filter	BRM50701	D - 93	MICRO-TRONICS	February, 2005	1 Year

Environmental conditions:

Temperature: 26 °C Humidity: 32 %

Transmitter Power (EIRP) Measurement

Test Procedure :

Step 1) The test was set-up shown as Fig.1 (a). In order to obtain the maximum emission, the EUT is placed at the height 1.8m on the non-conducted support, at the distance 3m from the receiving antenna (Horn Antenna) and rotated around 360 degrees. The receiving antenna height was varied from 1 m to 4 m. The EUT on the table was placed to be maximum emission against the receiving antenna polarized (Vertical and Horizontal). Then the meter reading of the spectrum analyzer at the maximum emission was A dB(μ V).

Step 2) The test was set-up shown as Fig.1 (b). The EUT was replaced to Horn antenna at the same polarized under the same condition as step 1. The RF power was fed to the transmitting Antenna (Horn Antenna) through the RF amplifier from the signal generator. In order to obtain the maximum emission level, the height of the receiving antenna is varied from 1 m to 4 m. The level of the signal generator was adjusted so that the meter reading of the spectrum analyzer at the maximum emission was A dB(μ V), same as the recorded level in step 1. Then the RF power into the substitution horn antenna was P(dBm).

The EIRP is calculated in the following equation.

$$\text{EIRP (dBm)} = P \text{ (dBm)} + G_h \text{ (dBi)}$$

Where, G_h (dBi) : Gain of the substitution horn antenna

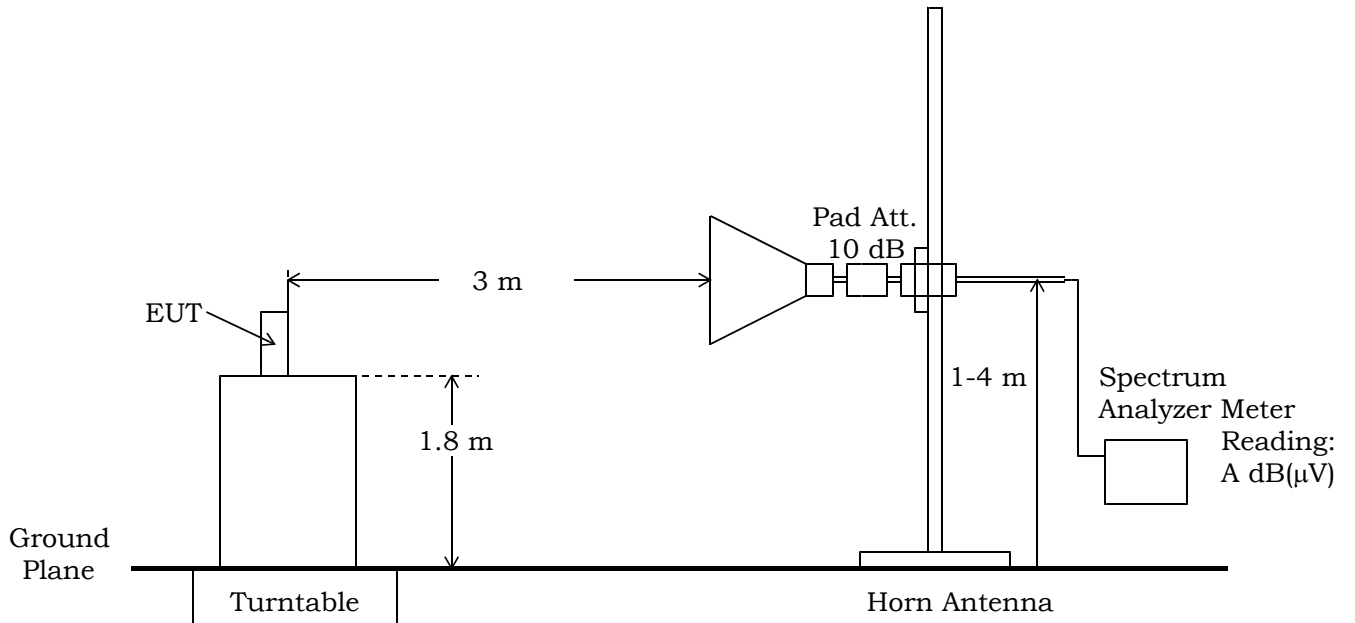

(a) EUT

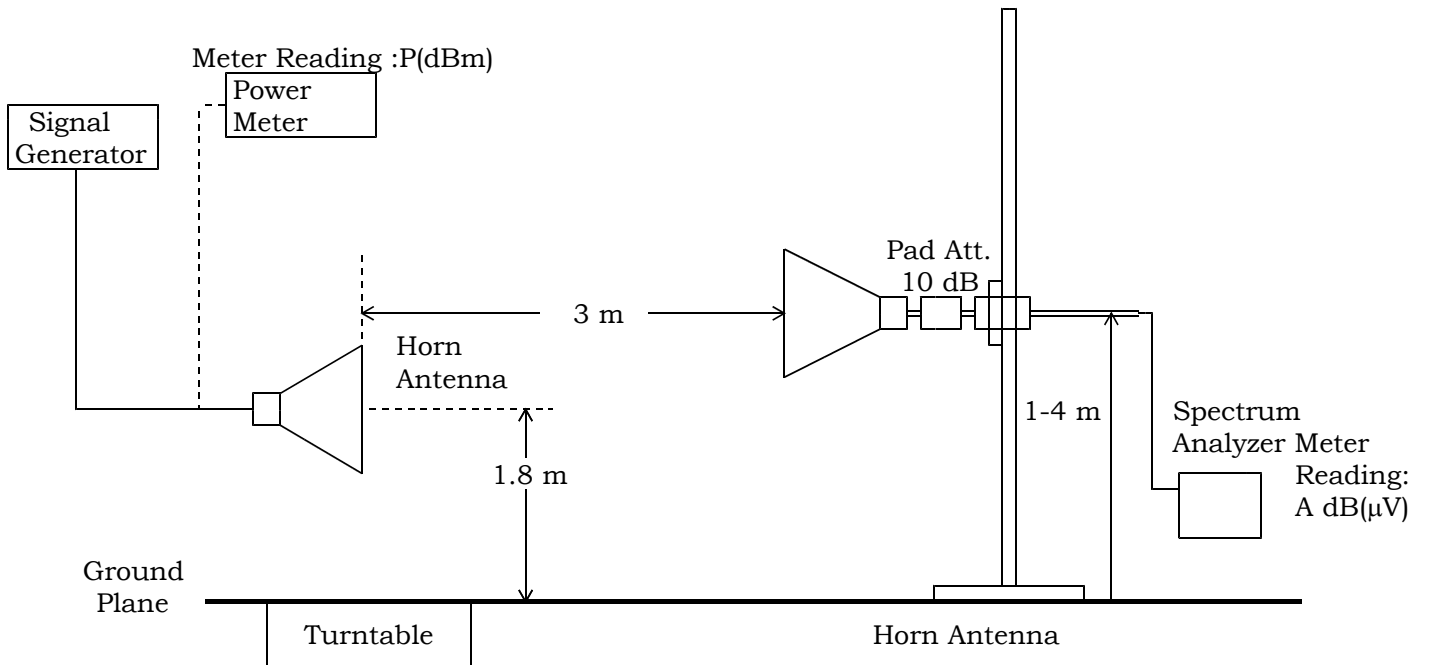

(b) Substitution Horn Antenna

Fig.1 Maximum Transmitter Power (EIRP) Measurement

Test location:

KITA-KANSAI Testing Center

7-7, Ishimaru, 1-Chome, Mino-Shi, Osaka, 562-0027, Japan

● - 1st open test site (3 meters)

KAMEOKA EMC Branch

9-1, Ozaki, Inukanno, Nishibetsuin-Cho, Kameoka-Shi, Kyoto, 621-0126, Japan

○ - 1st open test site ○ - 3 m ○ - 10 m ○ - 30 m

○ - 2nd open test site ○ - 3 m ○ - 10 m

Used test instruments:

Type	Model No.	Device ID	Manufacturer	Last Cal. Date	Cal. Interval
○ -SpectrumAnalyzer	8566B	A - 13	Agilent		
○ -SpectrumAnalyzer	8593A	A - 15	Agilent		
● -SpectrumAnalyzer	4446A	A - 39	Agilent	October, 2005	1 Year
○ -10dB Att.	4T-10	D - 73	Lucas Weinschel		
○ -10dB Att.	4T-10	D - 74	Lucas Weinschel		
○ -10dB Att.	54-10	D - 82	Lucas Weinschel		
○ -10dB Att.	54-10	D - 82	Lucas Weinschel		
● -10dB Att.	2-10	D - 40	Lucas Weinschel	June, 2005	1 Year
● -10dB Att.	MP721C	D - 65	Anritsu	October, 2005	1 Year
○ -Horn Ant.	91888-2	C - 40 - 1	EATON		
● -Horn Ant.	91889-2	C - 40 - 2	EATON	May, 2005	1 Year
○ -Horn Ant.	94613-1	C - 40 - 3	EATON		
○ -Horn Ant.	91888-2	C - 41 - 1	EATON		
● -Horn Ant.	91889-2	C - 41 - 2	EATON	May, 2005	1 Year
○ -Horn Ant.	94613-1	C - 41 - 3	EATON		
● -Cable	--	C - 40 - 11	HUBER+SUHNER	May, 2005	1 Year
○ -Cable	--	C - 40 - 12			
● -Cable	--	C - 65	HUBER+SUHNER	December, 2005	1 Year
● -Signal Generator	MG3681A	B - 3	Anritsu	February, 2005	1 Year
○ -Signal Generator	E8257D	B - 39	Agilent		
○ -Signal Generator	6062A	B - 44	Giga Tronics		
○ -Power Meter	E4417A	B - 51			
○ -Power Sensor	E9321A	B - 52			
○ -Power Sensor	E9323A	B - 59			
● -Power Meter	N1911A	B - 63	Agilent	August, 2005	1 Year
● -Power Sensor	N1921A	B - 64	Agilent	June, 2005	1 Year

Temperature: 26 °C Humidity: 32 %

Transmitter Power (TP) Measurement (Sec.15.247(b)(1))

Test Procedure :

The measurement test-setup is shown in Fig.2. The modulation is set to page 18.



Fig.2 Transmitter Power Measurement

Test location :

KITA-KANSAI Testing Center

7-7, Ishimaru, 1-Chome, Mino-Shi, Osaka, 562-0027, Japan

● - Shielded room

KAMEOKA EMC Branch

9-1, Ozaki, Inukanno, Nishibetsuin-Cho, Kameoka-Shi, Kyoto, 621-0126, Japan

○ - Shielded room

Used test instruments and sites :

Type	Model No.	Device ID	Manufacturer	Last Cal. Date	Cal. Interval
○ -Power Meter	E4417A	B - 51			
○ -Power Sensor	E9321A	B - 52			
○ -Power Sensor	E9323A	B - 59			
● -Power Meter	N1911A	B - 63	Agilent	August, 2005	1 Year
● -Power Sensor	N1921A	B - 64	Agilent	June, 2005	1 Year
○ -10dB Att.	54-10	D - 82	Lucas Weinschel		
● -10dB Att.	54-10	D - 83	Lucas Weinschel	May, 2005	1 Year
○ -10dB Att.	2-10	D - 79	Lucas Weinschel		
○ -10dB Att.	4T-10	D - 73	Lucas Weinschel		
○ -10dB Att.	4T-10	D - 74	Lucas Weinschel		
● -Cable	--	C - 51	HUBER+SUHNER	February, 2005	1 Year

Environmental conditions :

Temperature: 26 °C Humidity: 32 %

20dB Bandwidth Measurement (Sec.15.247(a)(1))

Test Procedure :

The measurement test-setup is shown in Fig.3. The modulation is set to page 18.

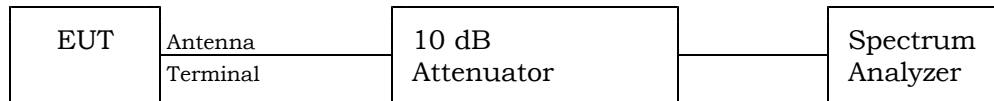

Fig.3 20dB Bandwidth Measurement

The setting of the spectrum analyzer are shown as follows :

Res. Bandwidth	27 kHz
Video Bandwidth	270 kHz
Span	3 MHz
Sweep Time	AUTO
Trace	Maxhold

Test location :

KITA-KANSAI Testing Center

7-7, Ishimaru, 1-Chome, Mino-Shi, Osaka, 562-0027, Japan

● - Shielded room

KAMEOKA EMC Branch

9-1, Ozaki, Inukanno, Nishibetsuin-Cho, Kameoka-Shi, Kyoto, 621-0126, Japan

○ - Shielded room

Used test instruments and sites :

Type	Model No.	Device ID	Manufacturer	Last Cal. Date	Cal. Interval
○ -Spectrum Analyzer	8566B	A- 13	Agilent		
● -SpectrumAnalyzer	4446A	A - 39	Agilent	October, 2005	1 Year
○ -10dB Att.	54-10	D - 82	Lucas Weinschel		
● -10dB Att.	54-10	D - 83	Lucas Weinschel	May, 2005	1 Year
○ -10dB Att.	2-10	D - 79	Lucas Weinschel		
○ -10dB Att.	4T-10	D - 73	Lucas Weinschel		
○ -10dB Att.	4T-10	D - 74	Lucas Weinschel		
● -Cable	--	C - 51	HUBER+SUHNER	February, 2005	1 Year

Environmental conditions :

Temperature: 26 °C Humidity: 32 %

Band-edge Emission Measurement (Sec.15.247(d))

Test Procedure :

The measurement test-setup is shown in Fig.4. The modulation is set to page 18.

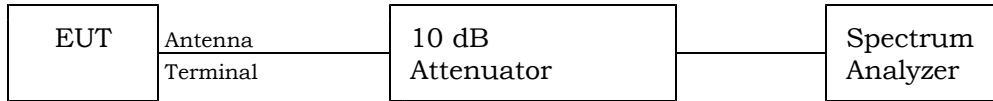

Fig.4 Band-Edge Emission Measurement

The setting of the spectrum analyzer are shown as follows :

TX Frequency	2400.914 MHz / 2480.293 MHz
Band-edge Frequency	2400.0 MHz / 2483.5 MHz
Res. Bandwidth	100 kHz
Video Bandwidth	300 kHz
Span	10 MHz
Sweep Time	AUTO
Trace	Maxhold

Test location :

KITA-KANSAI Testing Center

7-7, Ishimaru, 1-Chome, Mino-Shi, Osaka, 562-0027, Japan

● - Shielded room

KAMEOKA EMC Branch

9-1, Ozaki, Inukanno, Nishibetsuin-Cho, Kameoka-Shi, Kyoto, 621-0126, Japan

○ - Shielded room

Used test instruments and sites :

Type	Model No.	Device ID	Manufacturer	Last Cal. Date	Cal. Interval
○ -Spectrum Analyzer	8566B	A- 13	Agilent		
● -SpectrumAnalyzer	4446A	A - 39	Agilent	October, 2005	1 Year
○ -10dB Att.	54-10	D - 82	Lucas Weinschel		
● -10dB Att.	54-10	D - 83	Lucas Weinschel	May, 2005	1 Year
○ -10dB Att.	2-10	D - 79	Lucas Weinschel		
○ -10dB Att.	4T-10	D - 73	Lucas Weinschel		
○ -10dB Att.	4T-10	D - 74	Lucas Weinschel		
● -Cable	--	C - 51	HUBER+SUHNER	February, 2005	1 Year

Environmental conditions :

Temperature: 26 °C Humidity: 32 %

Carrier Frequency Separation Measurement (Sec.15.247(a)(1))

Test Procedure :

The measurement test-setup is shown in the Fig.6. The modulation is set to page 18.
 The transmitting frequency is set to 2440.156641 MHz (45ch) and 2441.050488 MHz (46ch).

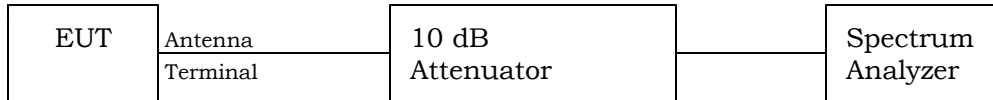

Fig.6 Carrier Frequency Separation Measurement

The setting of the spectrum analyzer are shown as follows :

Center Frequency	2440.6 MHz
Res. Bandwidth	100 kHz
Video Bandwidth	300 kHz
Span	5 MHz
Sweep Time	AUTO
Trace	Maxhold

Test location :

KITA-KANSAI Testing Center

7-7, Ishimaru, 1-Chome, Mino-Shi, Osaka, 562-0027, Japan

● - Shielded room

KAMEOKA EMC Branch

9-1, Ozaki, Inukanno, Nishibetsuin-Cho, Kameoka-Shi, Kyoto, 621-0126, Japan

○ - Shielded room

Used test instruments and sites :

Type	Model No.	Device ID	Manufacturer	Last Cal. Date	Cal. Interval
○ -Spectrum Analyzer	8566B	A- 13	Agilent		
● -SpectrumAnalyzer	4446A	A - 39	Agilent	October, 2005	1 Year
○ -10dB Att.	54-10	D - 82	Lucas Weinschel		
● -10dB Att.	54-10	D - 83	Lucas Weinschel	May, 2005	1 Year
○ -10dB Att.	2-10	D - 79	Lucas Weinschel		
○ -10dB Att.	4T-10	D - 73	Lucas Weinschel		
○ -10dB Att.	4T-10	D - 74	Lucas Weinschel		
● -Cable	--	C - 51	HUBER+SUHNER	February, 2005	1 Year

Environmental conditions :

Temperature: 26 °C Humidity: 32 %

CONFIGURATION OF EUT

The Equipment Under Test (EUT) consists of:

Description	Applicant (Manufacturer)	Model No. (Serial No.)	FCC ID
Fasimile with 2.4GHz FHSS Cordless Telephone (Base Unit)	Panasonic Communications Co., Ltd. (Panasonic Communications Co., Ltd.)	KX-FG2451 (--)	ACJ96NKX-FG2451

The measurement was carried out with the following equipment connected:

Description	Grantee/Distributor	Model No. (Serial No.)	FCC ID
None			

Type of Interface Cable(s) and the AC Power Cord used with the EUT:

	Description	Port	Shielded Cable	Shell Material	Ferrite Core	Cable Length
1	EUT ----- No termination	LINE ----- --	NO	-- ----- --	NO	1.8 m
2	AC Power Cord (EUT) 1φ 3-pin plug	--	NO	-- ----- --	NO	1.5 m

Operation - mode of the EUT:

The EUT was operated during the test under the following specification:

Transmitting
Modulation signal : TDMA/TDD Burst Type (FSK 190kHz dev.)

For operating condition of the EUT, the typical modulating signal is not used and input because the occupied bandwidth of the EUT is subject to restriction due to the bit rate of preamble data other than audio data in the transmitting data .

Test system:

The EUT has a DC IN port and a LINE port.

Special accessories:

None

EUT Modification

- - No modifications were conducted by JQA to achieve compliance to applied levels.
- - To achieve compliance to applied levels, the following change(s) were made by JQA during the compliance test.

The modification(s) will be implemented in all production models of this equipment.

Applicant : N/A Date : N/A

Typed Name : N/A Position : N/A

Responsible Party

Responsible Party of Test Item(Product)

Responsible party :

Contact Person :

Signatory

Deviation from Standard

- - No deviations from the standard described in page 3.
- - The following deviations were employed from the standard described in page 3.

TEST RESULTS

AC Powerline Conducted Emission 150 kHz - 30 MHz (Sec.15.207(a))

The requirements are	● - Passed	○ - Not Passed
Min. limit margin	<u>22.5</u> dB	at <u>0.20</u> MHz
Max. limit exceeding	<u> </u> dB	at <u> </u> MHz
Uncertainty of measurement results	<u>+ 2.1</u> dB(2 σ)	<u>- 2.1</u> dB(2 σ)

Remarks: _____

Electromagnetic Field Radiated Emission 9 kHz - 25 GHz

Spurious (Sec.15.247(d),15.205(a),15.209(a))

The requirements are	● - Passed	○ - Not Passed
Min. limit margin	More than <u>6.0</u> dB	at <u>7440.878319</u> MHz
Max. limit exceeding	<u> </u> dB	at <u> </u> MHz
Uncertainty of measurement results (≤ 30 MHz)	<u>+ 2.5</u> dB(2 σ)	<u>- 2.5</u> dB(2 σ)
Uncertainty of measurement results (30 MHz - 1000 MHz)	<u>+ 4.1</u> dB(2 σ)	<u>- 4.2</u> dB(2 σ)
Uncertainty of measurement results (≥ 1000 MHz)	<u>+ 3.1</u> dB(2 σ)	<u>- 3.2</u> dB(2 σ)

Remarks: _____

Maximum Peak Power (EIRP)Maximum Peak Power (EIRP) 112.1 mW at 2440.156641 MHz**Transmitter Power (TP) (Sec.15.247(b)(1))**

The requirements are ● - Passed ○ - Not Passed

The transmitter power is 66.1 mW at 2440.156641 MHzMin. limit margin 2.8 dB at 2440.156641 MHz

Max. limit exceeding _____ dB at _____ MHz

Uncertainty of measurement results ± 0.6 dB(2σ)**Remarks:** _____
_____**Antenna Gain of the EUT (Sec.15.247(b)(4))**The antenna gain is 2.3 dBi at 2440.156641 MHz**Remarks:** _____
_____**20dB Bandwidth (Sec.15.247(a)(1))**The 20 dB Bandwidth is 762 kHz at 2480.292773 MHzThe Occupied(99%) Bandwidth is 720 kHz at 2480.292773 MHz

The results Refer to pages* 2 - 4

Uncertainty of measurement results at Frequency ±5 kHz(2σ)Uncertainty of measurement results at Amplitude ± 0.6 dB(2σ)**Remarks:** *: The Page is one in the Attachment A.

Band-edge Emission (Sec.15.247(d))

The requirements are	● - Passed	○ - Not Passed
The Band-Edge level is	<u>-47.2</u> dBc at	<u>2400.00</u> MHz
The results	Refer to pages*	6 - 7
Uncertainty of measurement results at Frequency		<u>±10</u> kHz(2σ)
Uncertainty of measurement results at Amplitude		<u>± 0.6</u> dB(2σ)

Remarks: *: The Page is one in the Attachment A.

Carrier Frequency Separation (Sec.15.247(a)(1))

The requirements are	● - Passed	○ - Not Passed
Channel Separation		<u>900</u> kHz
The results	Refer to pages*	8
Uncertainty of measurement results at Frequency		<u>±5</u> kHz(2σ)
Uncertainty of measurement results at Amplitude		<u>± 0.6</u> dB(2σ)

Remarks: *: The Page is one in the Attachment A.

SUMMARY**GENERAL REMARKS :**

The EUT was tested according to the requirements of FCC Rules and Regulations Part 15 Subpart A and C under the test configuration, as shown in page 24.

The conclusion for the test items of which are required by the applied regulation is indicated under the final judgement.

FINAL JUDGEMENT :

The "as received" sample;

- - fulfill the test requirements of the regulation mentioned on page 3.
- - fulfill the test requirements of the regulation mentioned on page 3, but with certain qualifications.
- - doesn't fulfill the test regulation mentioned on page 3.

Begin of testing : December 27, 2005

End of testing : January 6, 2006

- JAPAN QUALITY ASSURANCE ORGANIZATION -

Reviewed by :

Testd by :



Akio Hosoda
Manager
EMC Div.
JQA KITA-KANSAI Testing Center

Shigeru Kinoshita
Deputy Manager
EMC Div.
JQA KITA-KANSAI Testing Center

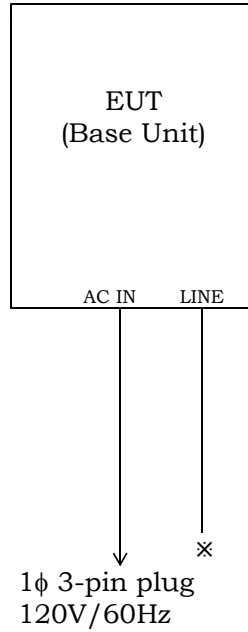
Test System-Arrangement (Drawings)

Note)
※ : No termination

Preliminary Test and Test-setup(Drawings)

AC Powerline Conducted Emission 150 kHz - 30 MHz:

The preliminary test was performed according to the description of ANSI C63.4-2003 Sec.7.2.3 (Exploratory AC Powerline Conducted Emission Measurements) and Sec.6.2.1 (Tabletop Equipment Tests).

The preliminary test was carried out to investigate the frequency of the emission that has the highest amplitude relative to the limits within normal operating modes, cable positions, and a typical system configuration. In order to find out to the maximum emission, the preliminary test and a final test were performed in accordance with the following steps.

Step 1: One operation mode of the test system was setting.

Step 2: Using both of a spectrum analyzer and a test receiver, the emission's circumstance from the system was monitored in one of ten divided frequency bands of the specified frequency range (150 kHz - 30 MHz). The maximum emission in the band was found by changing the typical cable positions or cable manipulation under a typical system configuration and by selecting of current-carrying conductor. The level and the frequency at the one point which are regarded as relative high emission in the band was measured and recorded. This step was repeated until the ending frequency band.

Step 3: Return to step 1, if the other operation mode was possible to be setting.

Step 4: Based on the collected results, the operation mode produced the maximum emission was selected. The final test on the selected operation mode was performed. But if it was difficult to select the operation mode, the final tests on all operation modes were performed.

Step 5: Based on the same data, as result if the final measurement, at the worst point that has the highest amplitude relative to the limit the repeatability of the worst was reconfirmed.

The photographs of the test system setup on the worst point were taken and recorded.

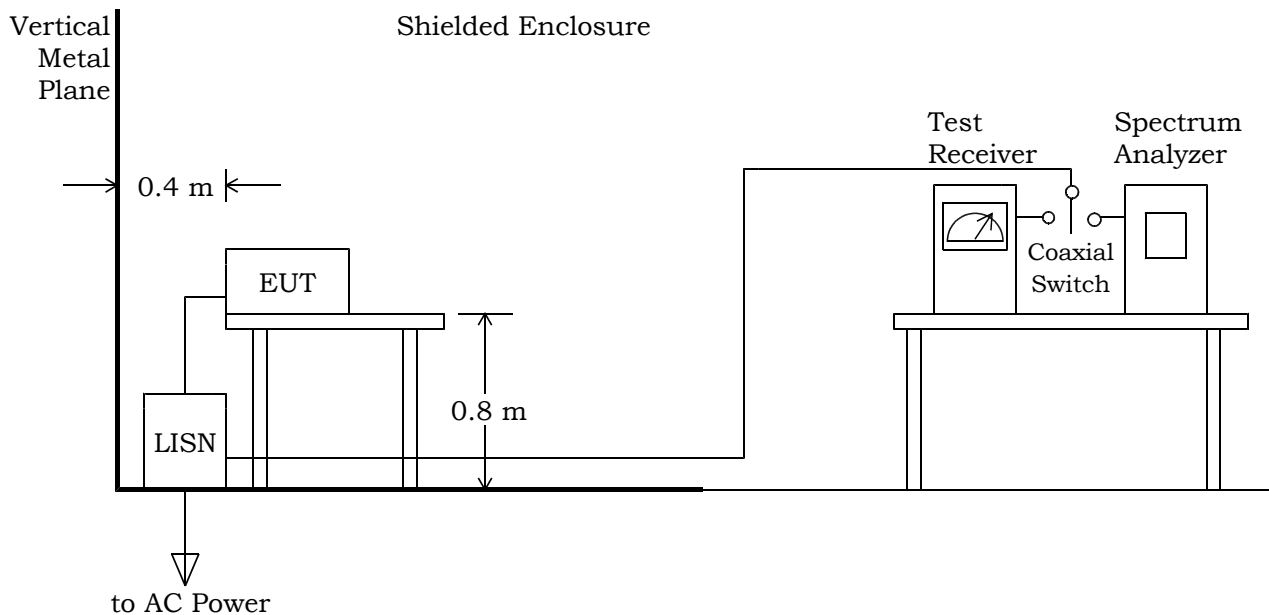

Radiated Emission (Magnetic Field) 9 kHz - 30 MHz:

The preliminary test was performed according to the description of ANSI C63.4-2003 Sec.8.3.1.1 (Exploratory Radiated Emission Measurements) and Sec.6.2.1 (Tabletop Equipment Tests).

The preliminary test was carried out to investigate the frequency of the emission that has the highest amplitude relative to the limits within normal operating modes, cable positions, and a typical system configuration. In order to find out to the maximum emission, the preliminary test and a final test were performed in accordance with the following steps.

Step 1: One operation mode of the test system was setting.

Step 2: In order to investigate the frequencies of maximum emissions, the loop antenna position was approached to the EUT and the significant frequency of the emission's circumstance from the test system were investigated. These data were recorded in the specified frequency band (9 kHz - 30 MHz).

Step 3: Using a test receiver and a loop antenna, the emission's circumstance from the test system was measured in according with ANSI C63.4-2003 Sec.8.3.1.2 (Final Radiated Emission Measurements) at each frequency which was found the higher emission referred to level vs. frequency on the list and which was measured by the loop antenna. The maximum emission was found by changing the antenna angle under a typical system configuration.

Step 4: Return to step 1, if the other operation mode was possible to be setting.

Step 5: The worst result was reported arranging data of which was obtained and performed by one or plural operation modes as the final test.

At the worst point that has the highest amplitude relative to the limit the repeatability of the level was reconfirmed. The photographs of the tests system setup on the worst point were taken and recorded.

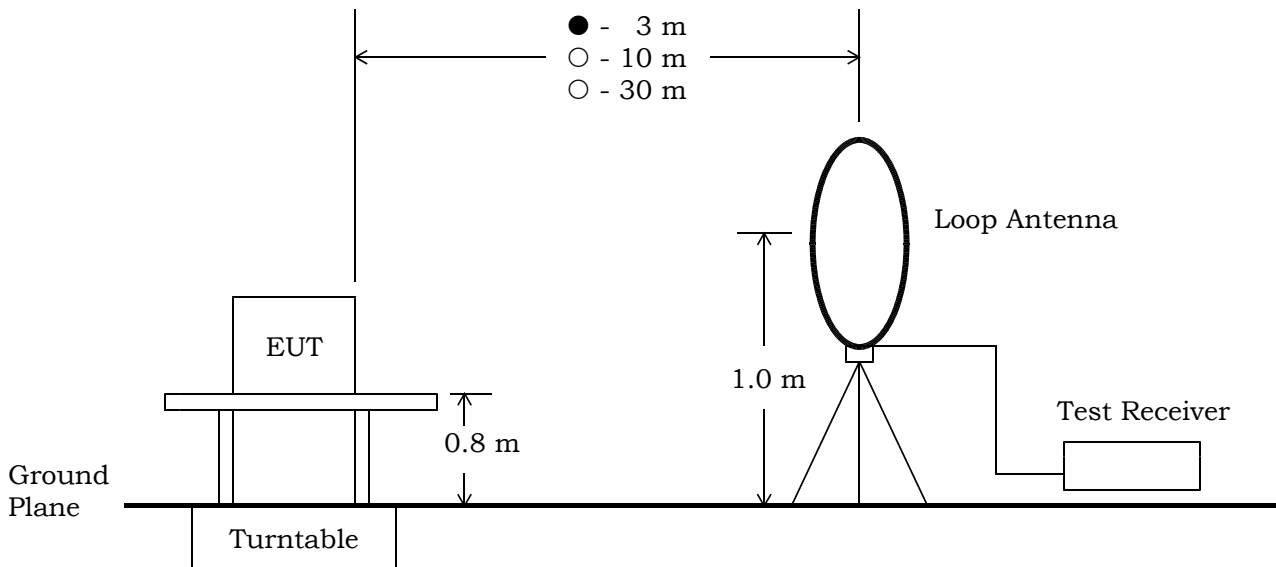

Electromagnetic Field Radiated Emission 30 MHz - 1000 MHz:

The preliminary test was performed according to the description of ANSI C63.4-2003 Sec.8.3.1.1 (Exploratory Radiated Emission Measurements) and Sec.6.2.1 (Tabletop Equipment Tests).

The preliminary test was carried out to investigate the frequency of the emission that has the highest amplitude relative to the limits within normal operating modes, cable positions, and a typical system configuration. In order to find out to the maximum emission, the preliminary test and a final test were performed in accordance with the following steps.

Step 1: One operation mode of the test system was setting.

Step 2: Using a test receiver and a test antenna probe, the significant frequency of the emission's circumstance from the test system were investigated. These data were recorded every one of 22 divided bands in the specified frequency band (30 MHz - 1000 MHz).

Step 3: Using a test receiver and a linearly polarized broadband antenna, the emission's circumstance from the test system was measured in according with ANSI C63.4-2003 Sec.8.3.1.2 (Final Radiated Emission Measurements) at each frequency which was found the higher emission referred to level vs. frequency on the list and which was measured by the linearly polarized broadband antenna. The maximum emission was found by changing the antenna angle under a typical system configuration.

Step 4: Return to step 1, if the other operation mode was possible to be setting.

Step 5: The worst result was reported arranging data of which was obtained and performed by one or plural operation modes as the final test.

At the worst point that has the highest amplitude relative to the limit the repeatability of the level was reconfirmed. The photographs of the tests system setup on the the worst point were taken and recorded.

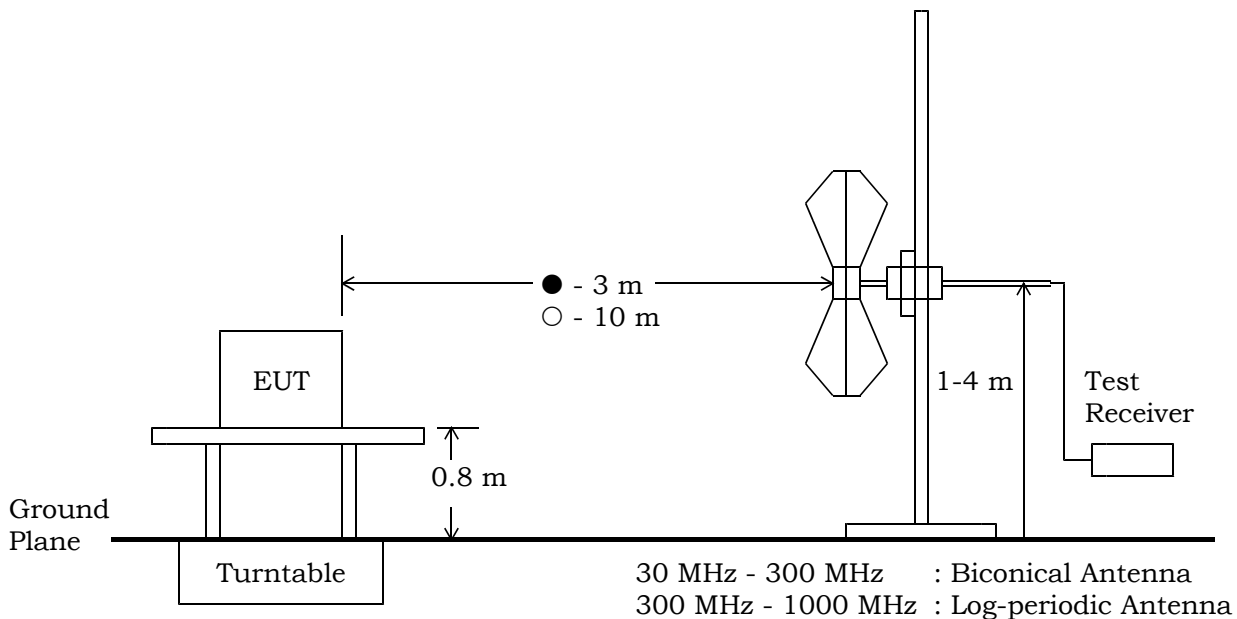

Electromagnetic Field Radiated Emission 1 GHz - 25 GHz:

The preliminary test was performed according to the description of ANSI C63.4-2003 Sec.8.3.1.1 (Exploratory Radiated Emission Measurements) and Sec.6.2.1 (Tabletop Equipment Tests).

The preliminary test was carried out to investigate the frequency of the emission that has the highest amplitude relative to the limits within normal operating modes, cable positions, and a typical system configuration. In order to find out to the maximum emission, the preliminary test and a final test were performed in accordance with the following steps.

Step 1: One operation mode of the test system was setting.

Step 2: In order to investigate the frequencies of maximum emissions, the horn antenna position was approached to the EUT and the significant frequency of the emission's circumstance from the test system were investigated. These data were recorded in the specified frequency band (1 GHz - 25 GHz).

Step 3: The emission's circumstance from the test system was measured in accordance with ANSI C63.4-2003, Sec.8.3.1.2 (Final Radiated Emissions Tests) at each frequency which was found higher emission referred to level vs. frequency on the list and which was measured in the specified distance using the horn antenna. The maximum emission was found by changing the antenna angle under a typical system configuration.

Step 4: Return to step 1, if the other operation mode was possible to be setting.

Step 5: The worst result was reported arranging data of which was obtained and performed by one or plural operation modes as the final test.

At the worst point that has the highest amplitude relative to the limit the repeatability of the level was reconfirmed. The photographs of the tests system setup on the worst point were taken and recorded.

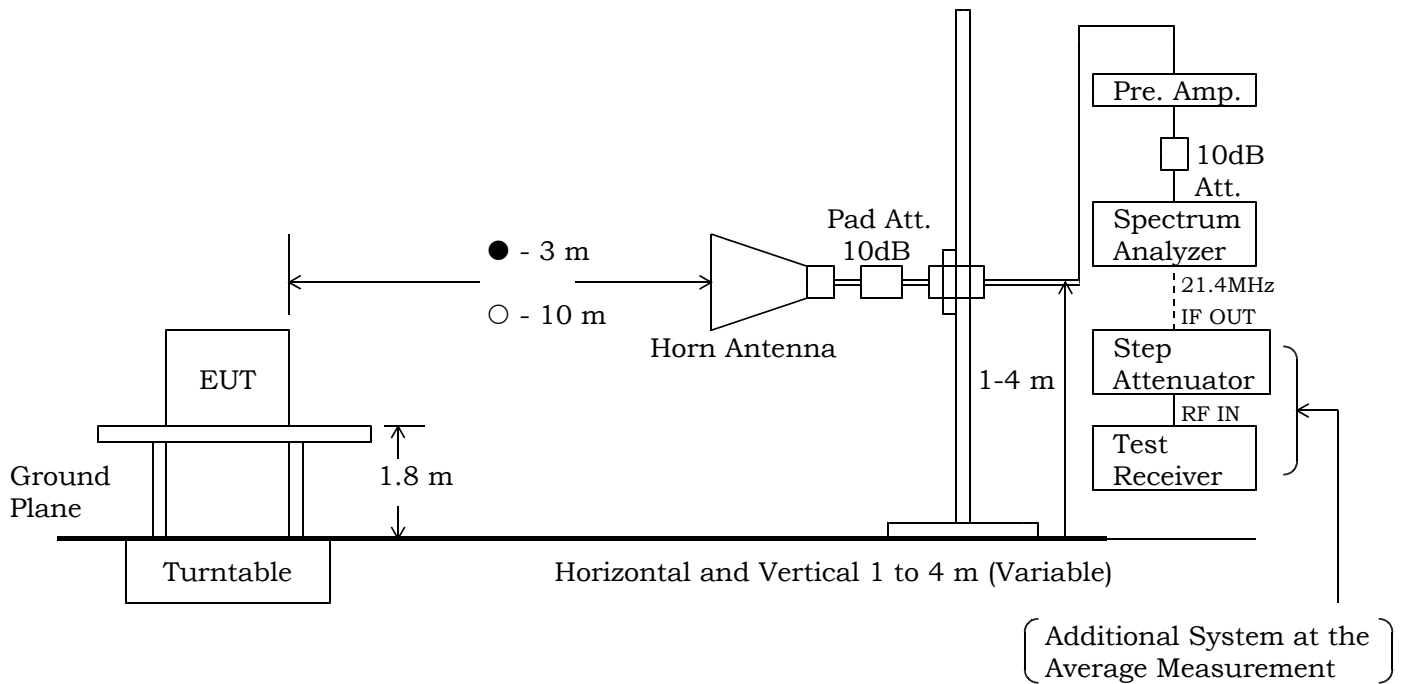

Spectrum Analyzer Setting:

Detector	*)Peak/Average
RES BW	1 MHz
VIDEO BW	1 MHz
SPAN	0 Hz

Test Receiver Setting:

SCALE	LINEAR	LINEAR
I.F.B.W.	1 MHz	1 MHz
Detector	Average	Peak

*) For the average measurement, it is made using a test receiver and a step attenuator.

Test-Setup (Photographs) at worst case

Conducted Emission



Front View

Radiated Emission



Horizontal Polarization



Side View

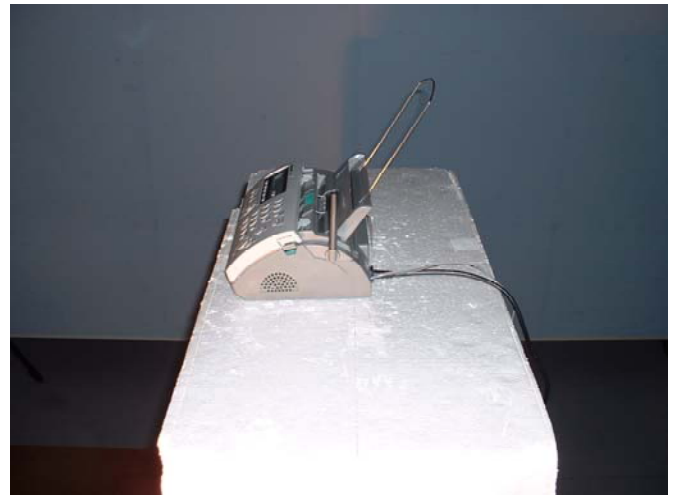

Vertical Polarization

AC Powerline Conducted Emission Measurement

Test Date: January 6, 2006

Temp.: 22 °C, Humi: 32 %

Test condition : Communicating(Hopping)

Frequency [MHz]	Corr. Factor [dB]	Meter Readings [dB(μV)]				Limits [dB(μV)]		Results [dB(μV)]		Margin [dB]	Remarks
		VA		VB		QP	AVE	QP	AVE		
0.15	0.2	41.0	--	41.0	--	66.0	56.0	41.2	--	+24.8	A
0.16	0.2	41.0	--	41.0	--	65.3	55.3	41.2	--	+24.1	A
0.20	0.2	41.0	--	41.0	--	63.7	53.7	41.2	--	+22.5	A
0.30	0.1	30.0	--	31.0	--	60.2	50.2	31.1	--	+29.1	A
0.61	0.1	25.0	--	26.0	--	56.0	46.0	26.1	--	+29.9	A
1.93	0.2	25.0	--	25.0	--	56.0	46.0	25.2	--	+30.8	A
3.28	0.3	30.0	--	30.0	--	56.0	46.0	30.3	--	+25.7	A
6.48	0.4	21.0	--	21.0	--	60.0	50.0	21.4	--	+38.6	A
14.70	0.6	< 20.0	--	< 20.0	--	60.0	50.0	< 20.6	--	> +39.4	A
30.00	0.9	< 20.0	--	< 20.0	--	60.0	50.0	< 20.9	--	> +39.1	A

Calculated result at 0.20 MHz, as the worst point shown on underline:

Corr. Factor = 0.2 dB
 +) Meter Reading = 41.0 dB(μV)
 Result = 41.2 dB(μV)
 Minimum Margin: 63.7 - 41.2 = 22.5 (dB)

NOTES

- The spectrum was checked from 0.15 MHz to 30 MHz.
- The correction factor includes the AMN insertion loss and the cable loss.
- The symbol of "<" means "or less".
- The symbol of ">" means "more than".
- The symbol of "--" means "not applicable".
- QP : Quasi-Peak Detector AVE : Average Detector
- Setting of measuring instrument(s) :

	Detector Function	IF Bandwidth
A	CISPR QP	9 kHz
B	Average	10 kHz

Electromagnetic Field Radiated Emission Measurement

Test Date: December 27, 2005

Temp.: 26 °C, Humi: 32 %

1. Fundamental Emission Results

CH	Transmitting Frequency [MHz]	Antenna Factor [dB(1/m)]	Corr. Factor [dB]	Meter Readings [dB(μV)]		Limits [dB(μV/m)]	Results [dB(μV/m)]		Margin [dB]	Remarks
				Hori.	Vert.		Hori.	Vert.		
01	2400.914355	21.5	10.7	82.3	82.4	--	114.5	114.6	--	E
45	2440.156641	21.4	10.7	82.3	83.6	--	114.4	115.7	--	E
90	2480.292773	21.4	10.7	83.2	83.2	--	115.3	115.3	--	E

2. Spurious Emission Results (over 1 GHz)

CH	Measured Frequency [MHz]	Antenna Factor [dB(1/m)]	Corr. Factor [dB]	Meter Readings [dB(μV)]		Limits [dB(μV/m)]	Results [dB(μV/m)]		Margin [dB]	Remarks
				Hori.	Vert.		Hori.	Vert.		
01	4801.828710	36.9	-20.5	< 45.0	46.0	74.0	< 61.4	62.4	+11.6	F
	7202.743065	37.3	-18.6	< 45.0	< 45.0	94.6	< 63.7	< 63.7	> +30.9	E
	9603.657420	39.5	-26.1	< 45.0	< 45.0	94.6	< 58.4	< 58.4	> +36.2	E
	12004.571775	43.8	-25.2	< 45.0	< 45.0	74.0	< 63.6	< 63.6	> +10.4	F
	14405.486130	45.5	-24.6	< 45.0	< 45.0	94.6	< 65.9	< 65.9	> +28.7	E
	16806.400485	44.3	-25.0	< 45.0	< 45.0	94.6	< 64.3	< 64.3	> +30.3	E
	19207.314840	40.2	-31.0	< 45.0	< 45.0	74.0	< 54.2	< 54.2	> +19.8	F
	21608.229195	40.3	-31.0	< 45.0	< 45.0	94.6	< 54.3	< 54.3	> +40.3	E
	24009.143550	40.4	-30.3	< 45.0	< 45.0	94.6	< 55.1	< 55.1	> +39.5	E
	4801.828710	36.9	-20.5	< 28.0	< 28.0	54.0	< 44.4	< 44.4	> + 9.6	G
	7202.743065	--	--	--	--	--	--	--	--	G
	9603.657420	--	--	--	--	--	--	--	--	G
	12004.571775	43.8	-25.2	< 28.0	< 28.0	54.0	< 46.6	< 46.6	> + 7.4	G
	14405.486130	--	--	--	--	--	--	--	--	G
16806.400485	--	--	--	--	--	--	--	--	G	
19207.314840	40.2	-31.0	< 28.0	< 28.0	54.0	< 37.2	< 37.2	> +16.8	G	
21608.229195	--	--	--	--	--	--	--	--	G	
24009.143550	--	--	--	--	--	--	--	--	G	

CH	Measured Frequency [MHz]	Antenna Factor [dB(1/m)]	Corr. Factor [dB]	Meter Readings [dB(μV)]		Limits [dB(μV/m)]	Results [dB(μV/m)]		Margin [dB]	Remarks
				Hori.	Vert.		Hori.	Vert.		
45	4880.313282	37.0	-20.5	45.0	46.0	74.0	61.5	62.5	+11.5	F
	7320.469923	37.7	-18.4	45.0	45.0	74.0	64.3	64.3	+ 9.7	F
	9760.626564	39.3	-26.0	< 45.0	< 45.0	95.7	< 58.3	< 58.3	> +37.4	E
	12200.783205	44.0	-25.1	< 45.0	< 45.0	74.0	< 63.9	< 63.9	> +10.1	F
	14640.939846	45.5	-24.7	< 45.0	< 45.0	95.7	< 65.8	< 65.8	> +29.9	E
	17081.096487	44.3	-25.0	< 45.0	< 45.0	95.7	< 64.3	< 64.3	> +31.4	E
	19521.253128	40.3	-30.9	< 45.0	< 45.0	74.0	< 54.4	< 54.4	> +19.6	F
	21961.409769	40.3	-29.6	< 45.0	< 45.0	95.7	< 55.7	< 55.7	> +40.0	E
	24401.566410	40.4	-30.5	< 45.0	< 45.0	95.7	< 54.9	< 54.9	> +40.8	E
	4880.313282	37.0	-20.5	< 28.0	< 28.0	54.0	< 44.5	< 44.5	> + 9.5	G
	7320.469923	37.7	-18.4	< 28.0	< 28.0	54.0	< 47.3	< 47.3	> + 6.7	G
	9760.626564	--	--	--	--	--	--	--	--	G
	12200.783205	44.0	-25.1	< 28.0	< 28.0	54.0	< 46.9	< 46.9	> + 7.1	G
	14640.939846	--	--	--	--	--	--	--	--	G
	17081.096487	--	--	--	--	--	--	--	--	G
	19521.253128	40.3	-30.9	< 28.0	< 28.0	54.0	< 37.4	< 37.4	> +16.6	G
	21961.409769	--	--	--	--	--	--	--	--	G
	24401.566410	--	--	--	--	--	--	--	--	G
90	4960.585546	37.1	-20.6	46.0	47.0	74.0	62.5	63.5	+10.5	F
	7440.878319	38.2	-18.2	45.0	45.0	74.0	65.0	65.0	+ 9.0	F
	9921.171092	39.1	-25.9	< 45.0	< 45.0	95.3	< 58.2	< 58.2	> +37.1	E
	12401.463865	44.1	-25.0	< 45.0	< 45.0	74.0	< 64.1	< 64.1	> + 9.9	F
	14881.756638	45.4	-24.8	< 45.0	< 45.0	95.3	< 65.6	< 65.6	> +29.7	E
	17362.049411	44.3	-25.1	< 45.0	< 45.0	95.3	< 64.2	< 64.2	> +31.1	E
	19842.342184	40.3	-30.8	< 45.0	< 45.0	74.0	< 54.5	< 54.5	> +19.5	F
	22322.634957	40.4	-30.4	< 45.0	< 45.0	74.0	< 55.0	< 55.0	> +19.0	F
	24802.927730	40.4	-30.2	< 45.0	< 45.0	95.3	< 55.2	< 55.2	> +40.1	E
	4960.585546	37.1	-20.6	< 28.0	< 28.0	54.0	< 44.5	< 44.5	> + 9.5	G
	7440.878319	38.2	-18.2	< 28.0	< 28.0	54.0	< 48.0	< 48.0	> + 6.0	G
	9921.171092	--	--	--	--	--	--	--	--	G
	12401.463865	44.1	-25.0	< 28.0	< 28.0	54.0	< 47.1	< 47.1	> + 6.9	G
	14881.756638	--	--	--	--	--	--	--	--	G
	17362.049411	--	--	--	--	--	--	--	--	G
	19842.342184	40.3	-30.8	< 28.0	< 28.0	54.0	< 37.5	< 37.5	> +16.5	G
	22322.634957	40.4	-30.4	< 28.0	< 28.0	54.0	< 38.0	< 38.0	> +16.0	G
	24802.927730	--	--	--	--	--	--	--	--	G
Band-Edge under FHSS operation										
	2390.000000	21.5	-21.3	43.0	48.0	74.0	43.2	48.2	+25.8	E
	2390.000000	21.5	-21.3	< 26.0	< 26.0	54.0	< 26.2	< 26.2	> +27.8	G
	2483.500000	21.4	-21.4	55.1	50.5	74.0	55.1	50.5	+18.9	E
	2483.500000	21.4	-21.4	< 32.0	< 32.0	54.0	< 32.0	< 32.0	> +22.0	G

Test Date: January 6, 2006
Temp.: 20 °C, Humi: 26 %

3. Spurious Emission Results (9 kHz - 1 GHz)

CH	Measured Frequency	Antenna Factor	Corr. Factor	Meter Readings		Limits	Results		Margin	Remarks
	[MHz]			[dB(1/m)]	[dB]		[dB(μV)]	[dB(μV/m)]		
				Hori.	Vert.		Hori.	Vert.		
45	59.0	8.2	1.1	< 13.0	< 23.0	40.0	< 22.3	< 32.3	> + 7.7	B
	72.1	6.5	1.3	8.0	< 15.0	40.0	15.8	< 22.8	> +17.2	B
	156.2	15.2	1.9	8.0	7.0	43.5	25.1	24.1	+18.4	B
	168.2	15.5	2.0	9.0	6.0	43.5	26.5	23.5	+17.0	B
	240.3	16.9	2.4	7.0	6.0	46.0	26.3	25.3	+19.7	B
	288.3	18.7	2.7	7.0	14.0	46.0	28.4	35.4	+10.6	B
	322.6	15.6	2.9	10.0	8.0	46.0	28.5	26.5	+17.5	B
	564.5	20.4	4.0	< 4.0	5.0	46.0	< 28.4	29.4	+16.6	B
	645.1	22.1	4.3	< 10.0	< 10.0	46.0	< 36.4	< 36.4	> + 9.6	B
	942.8	23.6	5.2	< 5.0	< 5.0	46.0	< 33.8	< 33.8	> +12.2	B

Sample of calculated result at 7440.878319 MHz, as the Minimum Margin point:

Antenna Factor	=	38.2 dB(1/m)
Corr. Factor	=	-18.2 dB
+) Meter Reading	=	<28.0 dB(μV)
Result	=	<48.0 dB(μV/m)

Minimum Margin: 54.0 - <48.0 = >6.0 (dB)

The point shown on “ _____ ” is the Minimum Margin Point.

Spurious emission limits are shown in Section 15.247(c). But such emissions which fall in the restricted bands, as defined in Section 15.205(a), limits are based on Section 15.209.

Also, as spurious emissions below 1 GHz were not due to the operations under the provisions of Section 15.247, these emissions were followed in the general requirements defined in Section 15.209.

Correction factor details:

Cable Loss [dB] (9 kHz - 1 GHz)

Cable Loss + 10dB Pad Att. [dB] SP:8566B (1.0 GHz - 3.6 GHz)

Cable Loss + 20dB Pad Att. + High Pass Filter Loss (D-42) - Pre-Amp. Gain [dB] SP:8566B (3.6 GHz - 7.6 GHz)

Cable Loss + 10dB Pad Att. - Pre-Amp. Gain [dB] SP:8566B (7.6 GHz - 18 GHz)

Cable Loss + 20dB Pad Att. - Pre-Amp. Gain [dB] SP:E4446A (over 18 GHz)

Note: The spectrum was scanned 9 kHz to 25 GHz and all emissions not reported were more than 20 dB below the applied limits.

Remarks:

Test Receiver:

	Detector Function	IF Bandwidth
A	CISPR QP	9 kHz
B	CISPR QP	120 kHz
C	Peak	1 MHz
D	Average	1 MHz

Spectrum Analyzer:

	Detector Function	Resolution B.W.	Video B.W.	Sweep Time
E	Peak	100 kHz	100 kHz	20 msec.
F	Peak	1 MHz	1 MHz	20 msec.
G	Average *	1 MHz	1 MHz	20 msec.

* For the average measurement method, it is made measurement using a test receiver, a step attenuator and a spectrum analyzer. (FCC REPLY No. 950523A)

Transmitter Power (EIRP) Measurement

Test Date: December 27, 2005
Temp.: 26 °C, Humi: 32 %

1. Measurement Results

CH	Transmitting Frequency [MHz]	Emission Measurement [dB(μV)]		Substitution Measurement [dB(μV)]		Supplied Power to Substitution Antenna [dBm]	Gain of Substitution Antenna [dB]
		Hori. (Mh)	Vert. (Mv)	Hori. (Msh)	Vert. (Msv)		
01	2400.914355	82.3	82.4	78.0	77.9	- 1.5	16.3
45	2440.156641	82.3	83.6	78.0	78.1	- 1.6	16.6
90	2480.292773	83.2	83.2	78.6	78.5	- 1.5	16.9

2. Calculation Results

CH	Transmitting Frequency [MHz]	Peak EIRP [dBm]		Maximum Peak EIRP [mW]	Limits [dBm]	Margin [dB]
		(EIRPh)	Vert. (EIRPv)			
01	2400.914355	19.1	19.3	85.1	N/A	N/A
45	2440.156641	19.3	20.5	112.2	N/A	N/A
90	2480.292773	20.0	20.1	102.3	N/A	N/A

Sample of calculated result at 2440.156641 MHz, as the Maximum Level point:

Emission Measurement Mv	=	83.6 dB(μV)
Substitution Measurement Msv	=	-78.1 dB(μV)
Supplied Power to Substitution Antenna	=	-1.6 dBm
+) Gain of Substitution Antenna	=	16.6 dB
Result	=	20.5 dBm = 112.2 mW

EIRPh = Mh - Msh + Ps + Gs

EIRPv = Mv - Msv + Ps + Gs

The point shown on “ ____ ” is the Maximum Level Point.

Remarks:

Detector Function	Resolution B.W.	V.B.W.	Sweep Time
Peak	1 MHz	1 MHz	20 msec.

Transmitter Power (TP) Measurement

Test Date: December 27, 2005
Temp.: 26 °C, Humi: 32 %

a) Supply Voltage : 102VAC

Transmitting Frequency		Correction Factor [dB]	Meter Reading Peak [dBm]	Results Peak		Limits [dBm]	Margin [dB]
CH	[MHz]			[dBm]	[mW]		
01	2400.914355	10.0	8.0	18.0	63.1	21.0	+ 3.0
45	2440.156641	10.0	8.2	18.2	66.1	21.0	+ 2.8
90	2480.292773	10.0	8.1	18.1	64.6	21.0	+ 2.9

b) Supply Voltage : 120VAC

Transmitting Frequency		Correction Factor [dB]	Meter Reading Peak [dBm]	Results Peak		Limits [dBm]	Margin [dB]
CH	[MHz]			[dBm]	[mW]		
01	2400.914355	10.0	8.0	18.0	63.1	21.0	+ 3.0
45	2440.156641	10.0	8.2	18.2	66.1	21.0	+ 2.8
90	2480.292773	10.0	8.1	18.1	64.6	21.0	+ 2.9

c) Supply Voltage : 138VAC

Transmitting Frequency		Correction Factor [dB]	Meter Reading Peak [dBm]	Results Peak		Limits [dBm]	Margin [dB]
CH	[MHz]			[dBm]	[mW]		
01	2400.914355	10.0	8.0	18.0	63.1	21.0	+ 3.0
45	2440.156641	10.0	8.2	18.2	66.1	21.0	+ 2.8
90	2480.292773	10.0	8.1	18.1	64.6	21.0	+ 2.9

Sample of calculated result at 2440.156641 MHz, as the Minimum Margin point:

Correction Factor	=	10.0 dBm
+) Meter Reading	=	8.2 dB
Result	=	18.2 dBm = 66.1 mW

Minimum Margin: 21.0 - 18.2 = 2.8 (dB)

The point shown on “ ____ ” is the Minimum Margin Point.

Note: The correction factor shows the attenuation pad loss including the short, low loss cable or adapter.

Remarks:

Detector Function	Resolution B.W.	V.B.W.	Sweep Time
Peak	1 MHz	1 MHz	20 msec.

Calculated Antenna Gain of the EUT

Antenna gain of the integrated antenna of the EUT : G_{EUT} [dBi]
 Transmitter power (measured) : TP [dBm] = tp [mW]
 Maximum Peak EIRP (measured) : EIRP [dBm] = eirp [mW]

If the antenna gain (G_{EUT}) is met the equations as follows.

$$G_{EUT} [\text{dBi}] = \text{EIRP} [\text{dBm}] - \text{TP} [\text{dBm}] = 10\log(\text{eirp} [\text{mW}] / \text{tp} [\text{mW}])$$

CH	Transmitting Frequency [MHz]	Maximum Peak EIRP [mW]	Transmitter Power [mW]	Calculated Antenna Gain [dBi]
01	2400.914355	85.1	63.1	1.3
45	2440.156641	112.2	66.1	2.3
90	2480.292773	102.3	64.6	2.0

Sample of calculated result at 2440.156641 MHz, as the Maximum Level point:

Maximum Peak EIRP	=	20.5 dBm = 112.2 mW
-) Transmitter Power	=	18.2 dBm = 66.1 mW
Result	=	2.3 dBi

The point shown on “ ____ ” is the Maximum Level Point.



20dB Bandwidth Measurement

Test Date: December 12, 2005
Temp.: 26 °C ; Humi.: 32 %

CH No.	Transmitting Frequency(MHz)	20dB Bandwidth	99% Bandwidth	Data Page*
1	2400.914355	719 kHz	687 kHz	Page 2
45	2440.156641	724 kHz	683 kHz	Page 3
90	2480.292773	762 kHz	720 kHz	Page 4

- Note) 1. *: The Data Page is one in Attachment A.
2. The point shown on " _____ " is the Maximum Margin Point.

Band-Edge Emission Measurement

Test Date: December 12, 2005

Temp.: 26 °C ; Humi.: 32 %

1) Low Band-Edge Measurement

CH	Transmitting Frequency(MHz)	Band-Edge Frequency(MHz)	Band-Edge Level[dBc]	Data Page*
1	2400.914355	2400.0	-47.2	Page 6

2) High Band-Edge Measurement

CH	Transmitting Frequency(MHz)	Band-Edge Frequency(MHz)	Band-Edge Level[dBc]	Data Page*
90	2480.292773	2483.5	-68.4	Page 7

- Note) 1. *: The Data Page is one in Attachment A.
2. The point shown on " _____ " is the Maximum Point.

Carrier Frequency Separation Measurement

Test Date: December 12, 2005
Temp.: 26 °C ; Humi.: 32 %

Measurement Results:

Transmitting Frequency No.1 : 2439.970 MHz (45 ch)
Transmitting Frequency No.2 : 2440.870 MHz (46 ch)
Channel Separation : 900 kHz
Data Page in Attachment A : Page 8

Sec.247(a)(1)(iii) CHANNEL SEPARATION/DWELL TIME

Compliance with other provision of Sec.15.247 is stated in Panasonic Communications Co., Ltd., as stated below:

Hopping channel carrier frequencies are separated by 891.871 kHz.

Each bearer is independent and hops at a rate of 100 hops/sec.

The hopping sequence is either table-generated or RNG-generated:

1. A table-generated hop sequence is 45 hops long, each channel is used exactly once in the sequence. Therefore, in a 18 second(0.4sec×45ch) period each frequency channel is used 40 times in that sequence.
2. An RNG-generated hop sequence is 1800 hops long, each channel is used exactly 40 times in the entire sequence. Therefore, in a 18 second period each frequency channel is used exactly 40 times in that sequence.

The hopping sequence contains 45 logical channels these are mapped-onto 45 physical channels using a mapping table.

The highest channel occupancy is when an FP has 4 traffic bearers (i.e. 8 slots utilized), each using the same hopping sequence. As shown previously, for a given sequence, in a 18 second period each frequency channel is exactly 40 times. A slot is 986.1 μsec. long, therefore the average time of occupancy on any frequency channel in a 18 second period is:

$$T = 986.1 \mu\text{sec} \times 40 \times 4 = 157.776 \text{ msec.}$$

As a comparison, the lowest channel occupancy is when only a single dummy bearer is being transmitted. The transmission is 0.33 msec. long, therefore the average time of occupancy on any frequency channel in a 18 second period is:

$$T = 0.33 \text{ msec.} \times 40 \times 1 = 13.2 \text{ msec.}$$

Note:

This system provides with 90 channels, in which 45 channels are used in each conversation.

While a conversation is done, if some interference comes, FP (Fixed Portion) or PP (Portable Portion) changes the interfered frequency channel to a vacant channel.

Therefore, the occupancy time may be shorter than a theoretical times (157.776 ms and 13.2 ms).

Sec.15.247(g)

In the case of the dummy bearer (which the FP transmits all the time it is powered up and operating), the hopping sequence cycles through the 45 hops in the selected hopping pattern and then repeats.

In the case of a traffic bearer presented with continuous data (which is the normal case, as this is a voice system), the hopping sequence cycles through the 1800 hops in the sequence and then repeats.

In the case of a traffic bearer transmitting short bursts (for example, which may happen if a PP has several failed attempts¹ to establish a traffic bearer), then the successive traffic bearers will start on different patterns (because the PSTN is incremented each frame).

Note, that this system is a voice system and short burst transmissions are not typical.

1)The protocol actually limits the number of re-tries to 11 before giving up on the connection.

Sec.15.247(h)

There is no coordination between transmitters for the purpose of the avoiding the simultaneous occupancy of hopping frequencies by multiple transmitters.

Communication only ever takes place between an FP and a PP, never between two FPs (It is actually impossible for an FP to receive an FP packet, because their respective 'sync-fields' are different).

An FP and a PP that have an active traffic bearer between them will share a common hopping sequence and hop sequence adaption information (i.e. 'swapped channels'). However, neither the FP nor the PP transmits this information to a 3rd party, for any purpose whatsoever.

This is even true when in a state of bearer hand-over, where the PP is simultaneously 'locked-onto' two FPs. The PP will know both FP's hopping sequences, but it does not share this information with either FP.

In actual fact, channel collisions between FPs and PPs can and will take place. These may result in reduced voice quality, but this has to be tolerated.

In the case of 'sequence collision' (where two transmitters, with overlapping radio cells, are using the same slot, pattern and phase within the pattern), this is detected by multiple consecutive corrupted packets. Each connection that is experiencing sequence collision will independently attempt to remedy the situation (either by pattern changing or by bearer hand-over, as discussed previously).