

SYM	NAME	QTY.	MATERIAL & SIZE	TREATMENT	REMARK
1	LENS	1			
2	LENS SHEET	1	PC		
3	POWER LED	1	ABS		
4	REAR CABINET	1	ABS		
5	FRONT CABINET	1	ABS		
6	INITIAL SET SW	1			
7	WIRELESS LED	1	ABS		
8	WIRELESS SW	1			
9	NAME LABEL	1	POLYESTER FILMS		
10	FCC LABEL	1	POLYESTER FILMS		
11	SERIAL No. LABEL	1	POLYESTER FILMS		
12	CODE LABEL	1	POLYESTER FILMS		
13	FLEXIBLE STAND	1			
14		1			
15		1			

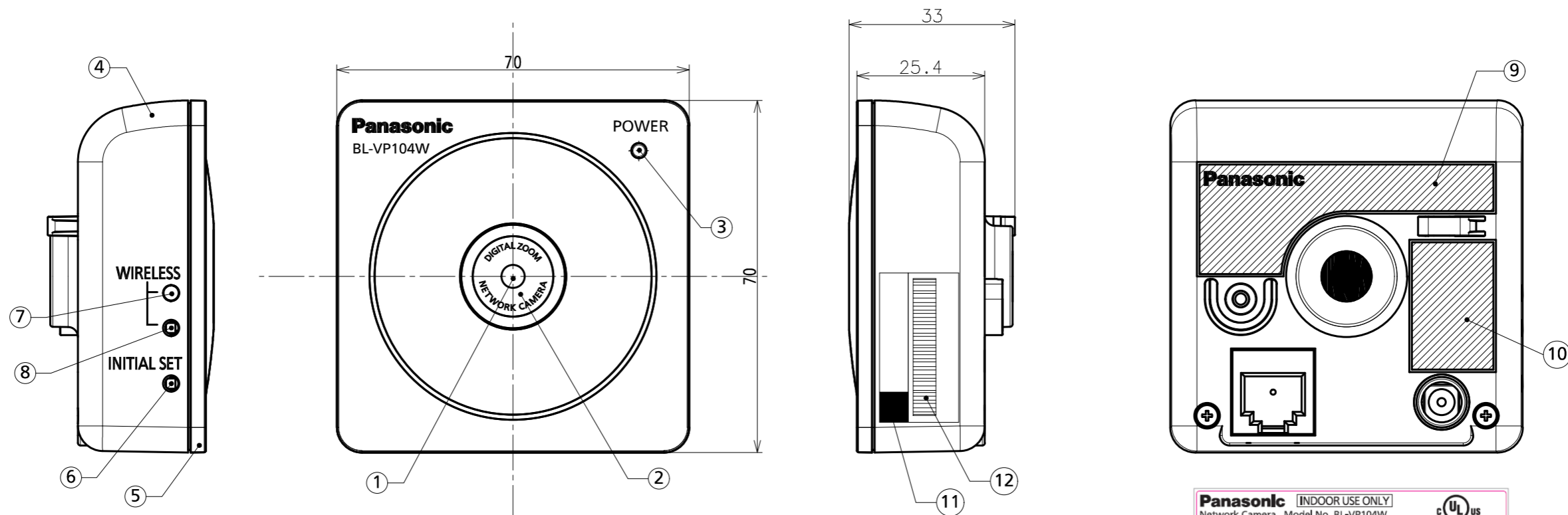

Panasonic INDOOR USE ONLY
 Network Camera Model No. BL-VP104W
 Power Source : 6.5 V \pm 500 mA
 FCC ID : ACJ96NBL-VP104W PGGT1127ZA
 Panasonic System Networks Co., Ltd.
 Made in China

UL LISTED
 L.T.C. 8822

USE ONLY WITH
 Panasonic AC ADAPTOR PQLV219.

THIS DEVICE COMPLIES WITH PART 15 OF THE FCC RULES. OPERATION IS SUBJECT TO THE FOLLOWING TWO CONDITIONS:
 1) THIS DEVICE MAY NOT CAUSE HARMFUL INTERFERENCE, AND
 2) THIS DEVICE MUST ACCEPT ANY INTERFERENCE RECEIVED, INCLUDING INTERFERENCE THAT MAY CAUSE UNDESIRABLE OPERATION.

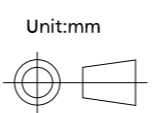
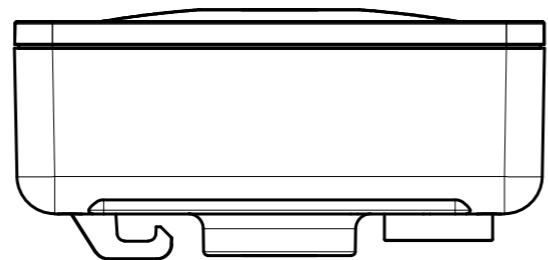

SCALE		DESIGNED		DRAWN		CHECKED		APPROVED		WEIGHT:Approx. 80g	MODEL	BL-VP104WP	
1 : 1		S.IKEGAMI 2012.01.27		S.IKEGAMI 2012.01.27							NAME		
											DRAWING/ Part NO.		
											REF.NO.	ISSUE 1-1	/