



## *EMC* EMISSION - TEST REPORT

JQA APPLICATION No. : KL80040294T

Name of Product : 2.4GHz Wireless Router

Model/Type No. : BB-HGW700A

FCC ID : ACJ96NBB-HGW700

Applicant : Panasonic Communications Co., Ltd.

Address : 1-62, 4-chome, Minoshima, Hakata-ku, Fukuoka 812-8531, Japan

Manufacturer : Panasonic Communications Co., Ltd.

Address : 1-62, 4-chome, Minoshima, Hakata-ku, Fukuoka 812-8531, Japan

Receive date of EUT : September 22, 2004

**Final Judgement** : **Passed**

**TEST RESULTS IN THIS REPORT** are obtained in use of equipment that is traceable to National Institute of Advanced Industrial Science and Technology (AIST) under METI Japan and Communications Research Lab. (CRL) under MPHPT Japan.

**THE TEST RESULTS** only responds to the test sample. This test report shall not be reproduced except in full.

Authorized by:

Takashi Yamanaka, Director  
JQA KITA-KANSAI Testing Center

## **DIRECTORY**

	<b>Page</b>
<b>A) Documentation</b>	
Directory	<u>2</u>
Test Regulation / General Information	<u>3 - 5</u>
Test Conditions	<u>6 - 16</u>
Configuration of EUT / Operation mode of the EUT	<u>17 - 18</u>
EUT Modification / Responsible Party / Deviation from Standard	<u>19</u>
Test results / Measurement Uncertainty	<u>20 - 22</u>
Summary	<u>23</u>
<b>Test System-Arrangement (Drawings)</b>	<u>24</u>
<b>Preliminary Test and Test-setup (Drawings)</b>	<u>25 - 28</u>
<b>Test-setup (Photographs) at worst case</b>	<u>29</u>
<b>B) Test data</b>	
Conducted Emission	150 kHz - 30 MHz <u>30</u>
Electromagnetic Field Radiated Emission	9 kHz - 25 GHz <u>31 - 36</u>
Maximum Peak Power (EIRP)	<u>37 - 38</u>
Transmitter Power (TP)	<u>39 - 40</u>
Antenna Gain of the EUT	<u>41</u>
6dB Bandwidth	<u>42</u>
Band-edge Emission	<u>43</u>
Peak Power Density	<u>44</u>

## TEST REGULATION

FCC Rules and Regulations Part 15 Subpart A and C (Effective October 7, 2004)

- Class A Digital Device
- Class B Digital Device
- Intentional Radiator (Sec.15.247)
- Receiver

### **Test items:**

- Sec.15.203 : Antenna requirement
- Sec.15.205 : Restricted bands of operation
- Sec.15.207 : Conducted limits
- Sec.15.209 : Radiated emission limits general requirements
- Sec.15.214 : Cordless Telephones
- Sec.15.247 : Operation within the bands 902-928MHz, 2400-2483.5MHz, 5725-5875MHz, and 24.0-24.25GHz

### **Test procedure:**

The test were performed according to the procedures in ANSI C63.4-2003.

## GENERAL INFORMATION

### **Test facility:**

- 1) Test Facility located at Kita-Kansai : 1st Open Sites (3 m Site)  
Test Facility located at Kameoka : 1st Open Site (3, 10 and 30 m, on common plane)  
: 2nd Open Site (3 and 10 m, on common plane)

**FCC filing No. : 31040/SIT 1300F2**

- 2) KITA-KANSAI TESTING CENTER is recognized under the National Voluntary Laboratory Accreditation Program for satisfactory compliance established in Title 15, Part 285 Code of Federal Regulations.

**NVLAP Lab Code: 200191-0**

- 3) Average Measurement Method  
**FCC filing No. : 950523A 1300F2**

### **Definitions for symbols used in this test report:**

- Black box indicates that the listed condition, standard or equipment is applicable for this Report.
- Blank box indicates that the listed condition, standard or equipment is not applicable for this Report.

**Description of the Equipment Under Test (EUT):**

- 1) Name : 2.4GHz Wireless Router
- 2) Model/Type No. : BB-HGW700A
- 3) Product Type : Pre-Production
- 4) Category : Intentional Radiator
- 5) EUT Authorization :  - Verification     - Certification     - D.o.C.
- 6) Transmitting Frequency : 2412 MHz (1ch) - 2462MHz (11ch)
- 7) Receiving Frequency : 2412 MHz (1ch) - 2462MHz (11ch)
- 8) Method/System : Digital Modulation
- 9) Type of Antenna : Dipole Antenna
- 10) Antenna Gain : 2.4 dBi(Rated)
- 11) Measured MAX Output Power : 17.8mW (Conducted)
- 12) Power Rating : AC 120V 60Hz 1 $\phi$  2-pin plug (AC Adapter : PQLV202)  
: (Rated,INPUT:AC100-120V,0.24A Max,OUTPUT DC12V0.75A)

**Detailed Transmitter portion (Channel plan):**

Transmitting frequency : 2412 MHz (1ch) - 2462MHz (11ch)  
Number of channel : 11  
Channel Separation : 5 MHz

**Modulation System Information:**

**IEEE802.11b**

Data Signaling Rate : 11Mbit/s, 5.5Mbit/s, 2Mbit/s and 1Mbit/s  
Media Access Protocol : CSMA/CA(Collision Avoidance)  
Base-Band Modulation : 11Mbit/s, 5.5Mbit/s : Complementary Code Keying(CCK) 8bits/symbol  
(before spreading) 2Mbit/s:DQPSK, 1Mbit/s:DBPSK  
Spread Spectrum : 1Mbit/s, 2Mbit/s : Direct Sequence with 11 chips/symbol interval.  
Pseudo random Barker code sequence:Chipping Rate: 11Mchips/s  
5.5Mbit/s, 11Mbit/s:Complementary Code Keying(CCK) 8bits/symbol  
Chipping Rate: 11Mchips/s  
Carrier Frequency : 2412-2462MHz(2412, 2417, 2422, 2427, 2432, 2437, 2442, 2447, 2452, 2457  
and 2462MHz)

**IEEE802.11g**

Data Signaling Rate : 54Mbit/s, 48Mbit/s, 36Mbit/s, 24Mbit/s, 18Mbit/s, 12Mbit/s, 9Mbit/s  
and 6Mbit/s  
Media Access Protocol : CSMA/CA(Collision Avoidance)  
Base-Band Modulation : 54Mbit/s, 48Mbit/s, 36Mbit/s, 24Mbit/s: 16QAM  
(before spreading) , 18Mbit/s, 12Mbit/s, 9Mbit/s and 6Mbit/s: BPSK  
Spread Spectrum : OFDM: 54Mbit/s, 48Mbit/s, 36Mbit/s, 24Mbit/s, 18Mbit/s, 12Mbit/s,  
9Mbit/s and 6Mbit/s  
Carrier Frequency : 2412-2462MHz(2412, 2417, 2422, 2427, 2432, 2437, 2442, 2447, 2452, 2457  
and 2462MHz)

**Detailed Receiver portion:**

Receiving frequency : 2412MHz (1ch) - 2462MHz (11ch)  
Local frequency : 672 MHz  
Intermediate frequency : 1740MHz (1ch) - 1790MHz (11ch)

**Other used (generated) frequencies in the EUT:**

Master Clock : 40 MHz  
Other Clock : 18.432 MHz, 25 MHz

## TEST CONDITIONS

**AC Powerline Conducted Emission Measurement (Sec.15.207(a))**  
was performed in the following test site.

### **Test location:**

KITA-KANSAI Testing Center

7-7, Ishimaru, 1-Chome, Mino-Shi, Osaka, 562-0027, Japan

● - Shielded room

KAMEOKA EMC Branch

9-1, Ozaki, Inukanno, Nishibetsuin-Cho, Kameoka-Shi, Kyoto, 621-0126, Japan

○ - Shielded room

○ - On metal plane of open site

### **Used test instruments and sites:**

Type	Model No.	Device ID	Manufacturer	Last Cal. Date	Cal. Interval
○ -Receiver	ESCS30	A - 1			
● -Receiver	ESH2	A - 2	Rohde&Schwrtz	May, 2004	1 Year
○ -Receiver	ESH2	A - 3		October, 2003	1 Year
● -AMN	KNW-407	D - 6	Kyuritsu		
○ -AMN	KNW-408	D - 11			
○ -AMN	KNW-242	D - 7			
○ -AMN	ESH3-Z5	D - 12			
○ -AMN	KNW-341C	D - 13			
○ -AMN	KNW-408	D - 14			
○ -AMN	KNW-244C	D - 77			
○ -AMN	KNW-408	D - 78			
○ -AMN	ESH2-Z5	D - 10			
○ -AMN	ESH2-Z3	D - 17			
○ -50Ω Terminator	65 BNC-50-0-1	H - 26			
○ -50Ω Terminator	65 BNC-50-0-1	H - 27			
○ -Cable	Cable	H - 7			
○ -Cable	Cable	H - 8	--	October, 2003	1 Year

### **Environmental conditions:**

Temperature: 22 °C Humidity: 60 %

**Magnetic Field Radiated Emission Measurement (Sec.15.247(d),15.205(a),15.209(a))**

was performed in the frequency range of 9 kHz - 30 MHz, in the following test site.

**Test location:**

KITA-KANSAI Testing Center

7-7, Ishimaru, 1-Chome, Mino-Shi, Osaka, 562-0027, Japan

● - 1st open test site (3 meters)

KAMEOKA EMC Branch

9-1, Ozaki, Inukanno, Nishibetsuin-Cho, Kameoka-Shi, Kyoto, 621-0126, Japan

○ - 1st open test site      ○ - 3 m      ○ - 10 m      ○ - 30 m  
○ - 2nd open test site      ○ - 3 m      ○ - 10 m

**Used test instruments:**

Type	Model No.	Device ID	Manufacturer	Last Cal. Date	Cal. Interval
● -Receiver	ESCS 30	A - 1	Rohde&Schwartz	August, 2004	1 Year
○ -Receiver	ESH 2	A - 2			
○ -Receiver	ESH 2	A - 3			
● -Loop Ant.	HFH2-Z2	C - 2	Rohde&Schwartz	July, 2004	1 Year
○ -Loop Ant.	HFH2-Z2	C - 3			
● -Cable	Cable	H - 28	Rohde&Schwartz	July, 2004	1 Year
○ -Cable	Cable	H - 29			

**Environmental conditions:**

Temperature: 22 °C      Humidity: 52 %

**Electromagnetic Field Radiated Emission Measurement (Sec.15.247(d),15.205(a),15.209(a))**

was performed in horizontal and vertical polarization, in the frequency range of 30 MHz - 1000 MHz, in the following test site.

**Test location:**

KITA-KANSAI Testing Center

7-7, Ishimaru, 1-Chome, Mino-Shi, Osaka, 562-0027, Japan

● - 1st open test site (3 meters)

KAMEOKA EMC Branch

9-1, Ozaki, Inukanno, Nishibetsuin-Cho, Kameoka-Shi, Kyoto, 621-0126, Japan

○ - 1st open test site      ○ - 3 m      ○ - 10 m      ○ - 30 m

○ - 2nd open test site      ○ - 3 m      ○ - 10 m

**Validation of Site Attenuation:**

1) Last Confirmed Date : October 9, 2003

2) Interval : 1 Year

**Used test instruments:**

Type	Model No.	Device ID	Manufacturer	Last Cal. Date	Cal. Interval
○ -Reciver/Pre. Amp.	ESV/ESV-Z3	A - 7 / A - 17			
● -Reciver/Pre. Amp.	ESV/ESV-Z3	A - 6 / A - 20	Rohde&Schwrtz	June, 2004	1 Year
○ -Reciver/Pre. Amp.	ESV/ESV-Z3	A - 4 / A - 18			
○ -Reciver/Pre. Amp.	ESV/ESV-Z3	A - 8 / A - 19			
○ -Reciver	ESVS 10	A - 5			
○ -Dipole Ant.	KBA-511A	C - 11			
○ -Dipole Ant.	KBA-611	C - 21			
● -Biconical Ant.	VHA9103/BBA9106	C - 43	Schwartzbeck	August, 2004	1 Year
● -Logperiodic Ant.	UHALP9107	C - 42	Schwartzbeck	August, 2004	1 Year
○ -Biconical Ant.	VHA9103/FBAB9177	C - 25			
○ -Logperiodic Ant.	UHALP9108-A1	C - 28			
● -Cable	---	H - 5	---	August, 2004	1 Year

**Environmental conditions:**

Temperature: 22 °C      Humidity: 52 %

**Electromagnetic Field Radiated Emission Measurement (Sec.15.247(d),15.205(a),15.209(a))**  
 was performed in horizontal and vertical polarization, in the frequency range of 1 GHz - 25 GHz,  
 in the following test site.

**Test location:**

KITA-KANSAI Testing Center

7-7, Ishimaru, 1-Chome, Mino-Shi, Osaka, 562-0027, Japan

● - 1st open test site (3 meters)

KAMEOKA EMC Branch

9-1, Ozaki, Inukanno, Nishibetsuin-Cho, Kameoka-Shi, Kyoto, 621-0126, Japan

○ - 1st open test site                      ○ - 3 m              ○ - 10 m              ○ - 30 m

○ - 2nd open test site                      ○ - 3 m              ○ - 10 m

**Used test instruments:**

Type	Model No.	Device ID	Manufacturer	Last Cal. Date	Cal. Interval
● -Receiver	ESCS30	A - 1	Rohde&Schwrtz	August, 2004	1 Year
● -SpectrumAnalyzer	8566B	A - 13	Agilent Technologies	March, 2004	1 Year
○ -SpectrumAnalyzer	8593A	A - 15			
○ -Receiver	ESV	A - 6			
● -10dB Att.	4T-10	D - 73	Lucus Weinschel	May, 2004	1 Year
● -10dB Att.	4T-10	D - 74	Lucus Weinschel	May, 2004	1 Year
● -Pre Amp.	WJ - 6 6 1 1 - 5 1 3	A - 23	Watokins Johnson	May, 2004	1 Year
● -Pre Amp.	WJ - 6 8 8 2 - 8 2 4	A - 21	Watokins Johnson	May, 2004	1 Year
● -Pre Amp.	DBL-0618N515	A - 33	DBS Microwave	May, 2004	1 Year
● -Horn Ant.	91888-2	C - 40 - 1	EATON	May, 2004	1 Year
● -Horn Ant.	91889-2	C - 40 - 2	EATON	May, 2004	1 Year
● -Horn Ant.	94613-1	C - 40 - 3	EATON	May, 2004	1 Year
● -Horn Ant.	91891-2	C - 40 - 4	EATON	May, 2004	1 Year
● -Horn Ant.	94614-1	C - 40 - 5	EATON	May, 2004	1 Year
● -Horn Ant.	3160-09	C - 48	EMCO	December, 2003	1 Year
● -Step Att.	355C	D - 22	Agilent Technologies	March, 2004	1 Year
● -Step Att.	355D	D - 23	Agilent Technologies	March, 2004	1 Year
● -Mixer.	MZ5010C	D - 81	Watokins Johnson	December, 2003	1 Year
● -Signal Generator	8673D	B - 2	Agilent Technologies	April, 2004	1 Year
● -Cable	--	C - 40 - 11	HUBER+SUHNER	May, 2004	1 Year
● -Cable	--	C - 40 - 12	HUBER+SUHNER	May, 2004	1 Year
● -HPF	UHP-127	D - 42	TAMAGAWA	May, 2004	1 Year

**Environmental conditions:**

Temperature: 26 °C      Humidity: 60 %

## **Maximum Peak Power (EIRP) Measurement**

### **Test Procedure :**

Step 1) The test was set-up shown as Fig.1 (a). In order to obtain the maximum emission, the EUT is placed at the height 1.8m on the non-conducted support, at the distance 3m from the receiving antenna (Horn Antenna) and rotated around 360 degrees. The receiving antenna height was varied from 1 m to 4 m. The EUT on the table was placed to be maximum emission against the receiving antenna polarized (Vertical and Horizontal). Then the meter reading of the spectrum analyzer at the maximum emission was A dB( $\mu$ V).

Step 2) The test was set-up shown as Fig.1 (b). The EUT was replaced to Horn antenna at the same polarized under the same condition as step 1. The RF power was fed to the transmitting Antenna (Horn Antenna) through the RF amplifier from the signal generator. In order to obtain the maximum emission level, the height of the receiving antenna is varied from 1 m to 4 m. The level of the signal generator was adjusted so that the meter reading of the spectrum analyzer at the maximum emission was A dB( $\mu$ V), same as the recorded level in step 1. Then the RF power into the substitution horn antenna was P(dBm).

The EIRP is calculated in the following equation.

$$\text{EIRP (dBm)} = P \text{ (dBm)} + G_h \text{ (dBi)}$$

Where,  $G_h$  (dBi) : Gain of the substitution horn antenna

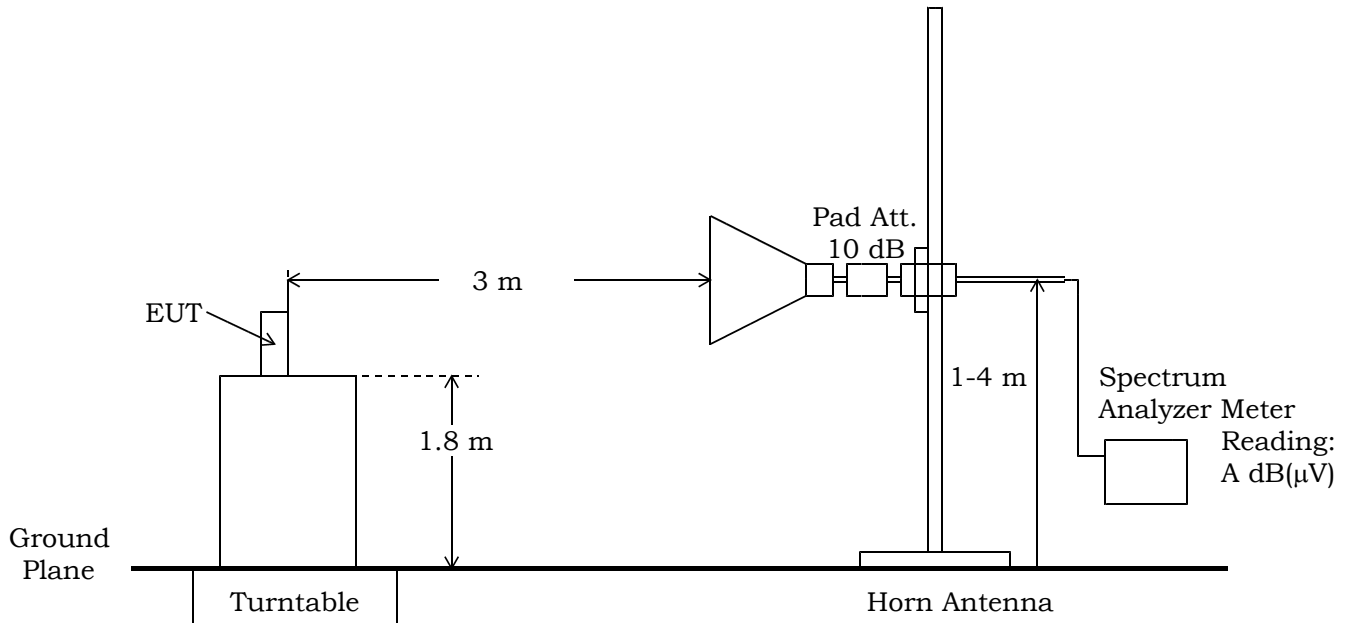

(a) EUT

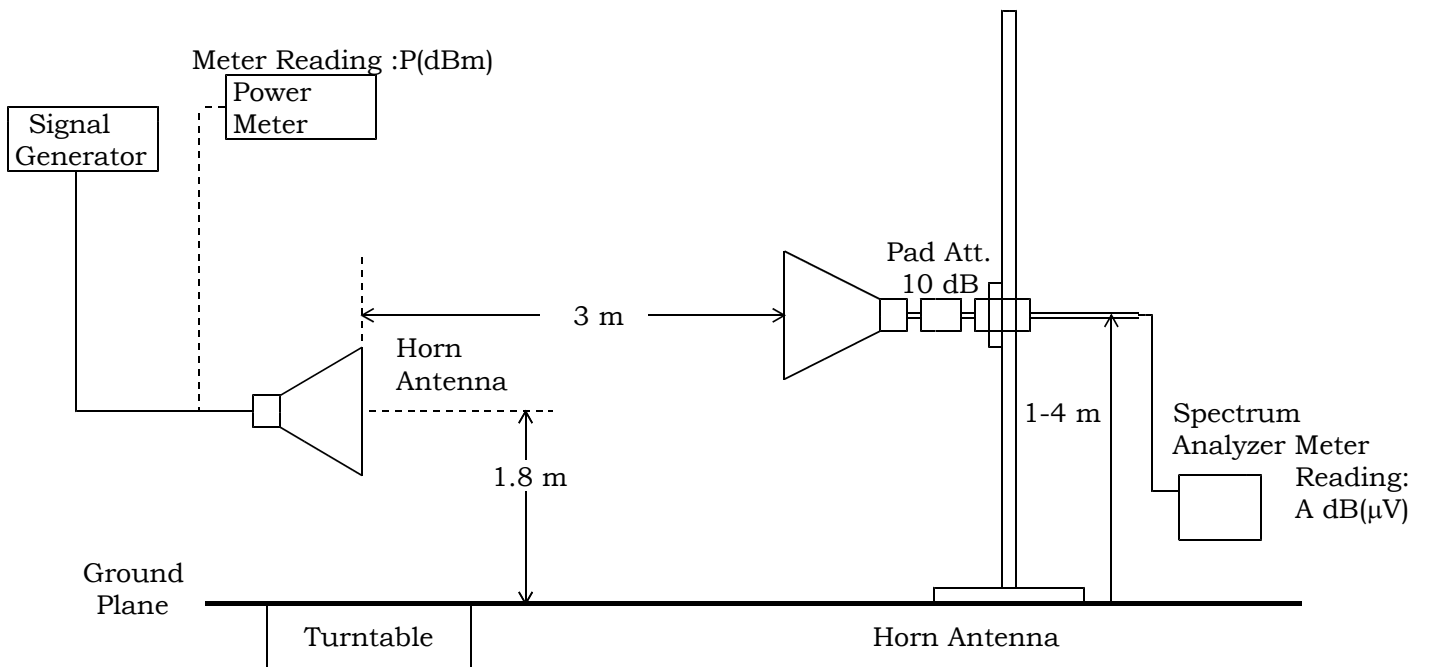

(b) Substitution Horn Antenna

Fig.1 Maximum Transmitter Power (EIRP) Measurement

**Test location:**

KITA-KANSAI Testing Center

7-7, Ishimaru, 1-Chome, Mino-Shi, Osaka, 562-0027, Japan

● - 1st open test site (3 meters)

KAMEOKA EMC Branch

9-1, Ozaki, Inukanno, Nishibetsuin-Cho, Kameoka-Shi, Kyoto, 621-0126, Japan

○ - 1st open test site                      ○ - 3 m            ○ - 10 m            ○ - 30 m

○ - 2nd open test site                      ○ - 3 m            ○ - 10 m

**Used test instruments:**

Type	Model No.	Device ID	Manufacturer	Last Cal. Date	Cal. Interval
○ -Receiver	ESCS30	A - 1			
○ -Receiver	ESCS30	A - 9			
● -SpectrumAnalyzer	8566B	A - 13	Agilent Technologies	March, 2004	1 Year
○ -SpectrumAnalyzer	8593A	A - 15			
○ -Receiver	ESV	A - 6			
○ -10dB Att.	4T-10	D - 73			
○ -10dB Att.	4T-10	D - 74			
○ -10dB Att.	2-10	D - 79			
● -10dB Att.	2-10	D - 80	Lucus Weinschel	September, 2004	1 Year
○ -Pre Amp.	WJ-6611-513	A - 23			
○ -Pre Amp.	WJ-6882-824	A - 21			
○ -Pre Amp.	DBL-0618N515	A - 33			
● -Horn Ant.	91888-2	C - 41 - 1	EATON	May, 2004	
● -Horn Ant.	91889-2	C - 40 - 2	EATON	May, 2004	1 Year
○ -Horn Ant.	91889-2	C - 41 - 2			1 Year
○ -Horn Ant.	94613-1	C - 40 - 3			
○ -Horn Ant.	91891-2	C - 40 - 4			
○ -Horn Ant.	94614-1	C - 40 - 5			
○ -Horn Ant.	3160-09	C - 48			
○ -Step Att.	355C	D - 22			
○ -Step Att.	355D	D - 23			
○ -Mixer	MZ5010C	D - 81			
● -Cable	--	C - 40 - 11	HUBER+SUHNER	May, 2004	1 Year
● -Cable	--	C - 40 - 12	HUBER+SUHNER	May, 2004	1 Year
● -Power Meter	E4417A	B - 51	Agilent Technologies	August, 2004	1 Year
● -Power Sensor	E9321A	B - 52	Agilent Technologies	May, 2004	1 Year
● -Signal Generator	MG3681A	B - 3	Anritsu	February, 2004	1 Year
○ -Signal Generator	6062A	B - 44			

Temperature: 26 °C      Humidity: 60 %

**Transmitter Power (TP) Measurement (Sec.15.247(b)(3))**

**Test Procedure :**

The measurement test-setup is shown in Fig.2. The modulation is set to page 18.

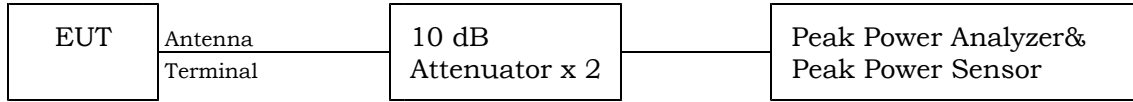

Fig.2 Transmitter Power Measurement

**Test location :**

KITA-KANSAI Testing Center  
 7-7, Ishimaru, 1-Chome, Mino-Shi, Osaka, 562-0027, Japan

● - Shielded room

KAMEOKA EMC Branch

9-1, Ozaki, Inukanno, Nishibetsuin-Cho, Kameoka-Shi, Kyoto, 621-0126, Japan

○ - Shielded room

**Used test instruments and sites :**

Type	Model No.	Device ID	Manufacturer	Last Cal. Date	Cal. Interval
● -Peak Power Analyzer	8990A	100-02-016	Agilent Technologies	April, 2004	1 Year
● -Peak Power Sensor	84815A	100-02-016	Agilent Technologies	April, 2004	1 Year
● -10dB Att.	54-10	D - 82	Lucus Weinschel	November, 2003	1 Year
● -10dB Att.	54-10	D - 83	Lucus Weinschel	November, 2003	1 Year
○ -10dB Att.	2-10	D - 79			
○ -10dB Att.	4T-10	D - 73			
○ -10dB Att.	4T-10	D - 74			
● -Cable	--	C - 40 - 11	HUBER+SUHNER	May, 2004	1 Year

**Environmental conditions :**

Temperature: 24 °C      Humidity: 60 %

**6dB Bandwidth Measurement (Sec.15.247(a)(2))**

**Test Procedure :**

The measurement test-setup is shown in Fig.3. The modulation is set to page 18.

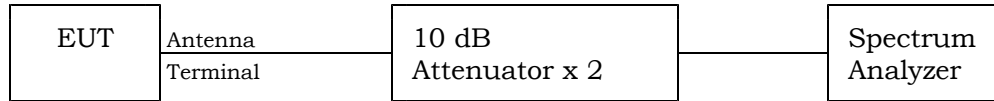

Fig.3 6dB Bandwidth Measurement

The setting of the spectrum analyzer are shown as follows :

Res. Bandwidth	100 kHz
Video Bandwidth	300 kHz
Span	30 MHz
Sweep Time	AUTO
Trace	Maxhold

**Test location :**

KITA-KANSAI Testing Center

7-7, Ishimaru, 1-Chome, Mino-Shi, Osaka, 562-0027, Japan

● - Shielded room

KAMEOKA EMC Branch

9-1, Ozaki, Inukanno, Nishibetsuin-Cho, Kameoka-Shi, Kyoto, 621-0126, Japan

○ - Shielded room

**Used test instruments and sites :**

Type	Model No.	Device ID	Manufacturer	Last Cal. Date	Cal. Interval
● -Spectrum Analyzer	8566B	A - 13	Agilent Technologies	March, 2004	1 Year
● -10dB Att.	54-10	D - 82	Lucus Weinschel	November, 2003	1 Year
● -10dB Att.	54-10	D - 83	Lucus Weinschel	November, 2003	1 Year
○ -10dB Att.	2-10	D - 79			
○ -10dB Att.	4T-10	D - 73			
○ -10dB Att.	4T-10	D - 74			
● -Cable	--	C - 40 - 11	HUBER+SUHNER	May, 2004	1 Year

**Environmental conditions :**

Temperature:  24  °C      Humidity:  60  %

**Band-edge Emission Measurement (Sec.15.247(d))**

**Test Procedure :**

The measurement test-setup is shown in Fig.4. The modulation is set to page 18.

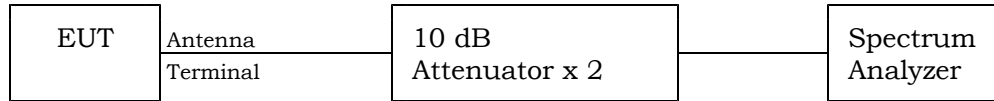

Fig.4 Band-Edge Emission Measurement

The setting of the spectrum analyzer are shown as follows :

TX Frequency	2412 MHz / 2462 MHz
Band-edge Frequency	2400.0 MHz / 2483.5 MHz
Res. Bandwidth	100 kHz
Video Bandwidth	300 kHz
Span	75 MHz
Sweep Time	AUTO
Trace	Maxhold

**Test location :**

KITA-KANSAI Testing Center

7-7, Ishimaru, 1-Chome, Mino-Shi, Osaka, 562-0027, Japan

● - Shielded room

KAMEOKA EMC Branch

9-1, Ozaki, Inukanno, Nishibetsuin-Cho, Kameoka-Shi, Kyoto, 621-0126, Japan

○ - Shielded room

**Used test instruments and sites :**

Type	Model No.	Device ID	Manufacturer	Last Cal. Date	Cal. Interval
● -Specterum Analyzer	8566B	A - 13	Agilent Technologies	March, 2004	1 Year
● -10dB Att.	54-10	D - 82	Lucus Weinschel	November, 2003	1 Year
● -10dB Att.	54-10	D - 83	Lucus Weinschel	November, 2003	1 Year
○ -10dB Att.	2-10	D - 79			
○ -10dB Att.	4T-10	D - 73			
○ -10dB Att.	4T-10	D - 74			
● -Cable	--	C - 40 - 11	HUBER+SUHNER	May, 2004	1 Year

**Environmental conditions :**

Temperature: 24 °C      Humidity: 60 %

**Peak Power Density Measurement (Sec.15.247(e))**

**Test Procedure :**

The measurement test-setup is shown in Fig.5. The modulation is set to page 18.

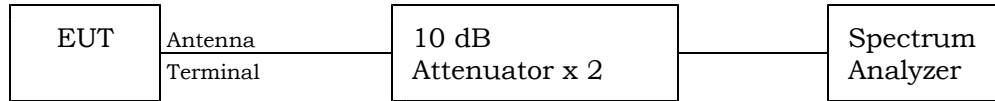

Fig.5 Peak Power Density Measurement

The setting of the spectrum analyzer are shown as follows :

Res. Bandwidth	3 kHz
Video Bandwidth	10 kHz
Span	20 MHz
Sweep Time	AUTO
Trace	Maxhold

**Test location :**

KITA-KANSAI Testing Center

7-7, Ishimaru, 1-Chome, Mino-Shi, Osaka, 562-0027, Japan

● - Shielded room

KAMEOKA EMC Branch

9-1, Ozaki, Inukanno, Nishibetsuin-Cho, Kameoka-Shi, Kyoto, 621-0126, Japan

○ - Shielded room

**Used test instruments and sites :**

Type	Model No.	Device ID	Manufacturer	Last Cal. Date	Cal. Interval
● -Specterum Analyzer	8566B	A - 13	Agilent Technologies	March, 2004	1 Year
● -10dB Att.	54-10	D - 82	Lucus Weinschel	November, 2003	1 Year
● -10dB Att.	54-10	D - 83	Lucus Weinschel	November, 2003	1 Year
○ -10dB Att.	2-10	D - 79			
○ -10dB Att.	4T-10	D - 73			
○ -10dB Att.	4T-10	D - 74			
● -Cable	--	C - 40 - 11	HUBER+SUHNER	May, 2004	1 Year

**Environmental conditions :**

Temperature: 24 °C      Humidity: 60 %

**CONFIGURATION OF EUT**

**The Equipment Under Test (EUT) consists of:**

Description	Applicant (Manufacturer)	Model No. (Serial No.)	FCC ID
Wireless Router	Panasonic Communications Co., Ltd. (Panasonic Communications Co., Ltd.)	BB-HGW700A (--)	ACJ96N BB-HGW700
AC Adaptor	Panasonic Communications Co., Ltd. (Panasonic Communications Co., Ltd.)	PQLV202 (--)	N/A

**The measurement was carried out with the following equipment connected:**

Description	Grantee/Distributor	Model No. (Serial No.)	FCC ID
None			

**Type of Interference Cable(s) and the AC Power Cord used with the EUT:**

	Description	Port	Shielded Cable	Shell Material	Ferrite Core	Cable Length
1	EUT	WAN	NO	--	NO	2.0 m
	No termination	--				
2	EUT	LAN1-LAN4	NO	--	NO	2.0 m
	No termination	--				
3	DC Power Cord (EUT / AC Adaptor)	--	NO	--	NO	2.8 m
4	AC Power Cord (AC Adaptor) 1φ 2-pin plug	--	NO	--	NO	1.8 m

### **Operation - mode of the EUT:**

The EUT was operated during the test under the following specification:

Transmitting

Modulation signal : PN9

The Data Signaling Rate is set as follows:

IEEE802.11b : 11Mbit/s

IEEE802.11g : 54Mbit/s

For operating condition of the EUT, the typical modulating signal is not used and input because the occupied bandwidth of the EUT is subject to restriction due to the bit rate of preamble data other than audio data in the transmitting data .

### **Test system:**

The EUT has one WAN port, 4 LAN(LAN1-LAN4) ports and one DC IN port.

### **Special accessories:**

None



**TEST RESULTS**

**AC Powerline Conducted Emission 150 kHz - 30 MHz (Sec.15.207(a))**

The requirements are **● - Passed** **○ - Not Passed**  
Min. limit margin 18.7 dB at 3.95 MHz  
Max. limit exceeding \_\_\_\_\_ dB at \_\_\_\_\_ MHz  
Uncertainty of measurement results + 2.1 dB(2σ) - 2.1 dB(2σ)

**Remarks:** \_\_\_\_\_  
\_\_\_\_\_

**Electromagnetic Field Radiated Emission 9 kHz - 25 GHz**

**Spurious (Sec.15.247(d),15.205(a),15.209(a))**

The requirements are **● - Passed** **○ - Not Passed**  
Min. limit margin More than 3.2 dB at 14472.0 MHz  
Max. limit exceeding \_\_\_\_\_ dB at \_\_\_\_\_ MHz  
Uncertainty of measurement results ( $\leq 30$  MHz) + 2.5 dB(2σ) - 2.5 dB(2σ)  
Uncertainty of measurement results (30 MHz - 1000 MHz) + 4.1 dB(2σ) - 4.2 dB(2σ)  
Uncertainty of measurement results ( $\geq 1000$  MHz) + 3.1 dB(2σ) - 3.2 dB(2σ)

**Remarks:** \_\_\_\_\_  
\_\_\_\_\_

**Maximum Peak Power (EIRP)**

Maximum Peak Power (EIRP) 30.2 mW at 2437.0 MHz

**Transmitter Power (TP) (Sec.15.247(b)(3))**

The requirements are **● - Passed** **○ - Not Passed**

The transmitter power is 17.8 mW at 2412.0 MHz

Min. limit margin 17.5 dB at 2412.0 MHz

Max. limit exceeding \_\_\_\_\_ dB at \_\_\_\_\_ MHz

Uncertainty of measurement results ± 0.6 dB(2σ)

**Remarks:** \_\_\_\_\_  
\_\_\_\_\_

**Antenna Gain of the EUT (Sec.15.247(b)(4))**

The antenna gain is 2.3 dBi at 2462.0 MHz

**Remarks:** \_\_\_\_\_  
\_\_\_\_\_

**6dB Bandwidth (Sec.15.247(a)(2))**

The 6dB Bandwidth is 11.41 MHz at 2437.0 MHz

The results Refer to pages\* 2 - 7

Uncertainty of measurement results at Frequency ±700 kHz(2σ)

Uncertainty of measurement results at Amplitude ± 0.6 dB(2σ)

**Remarks:** \*: The Page is one in the Attachment A.  
\_\_\_\_\_

**Band-edge Emission (Sec.15.247(d))**

The requirements are	<b>● - Passed</b>	<b>○ - Not Passed</b>
The Band-Edge level is	<u>-28.4</u> dBc at	<u>2400.00</u> MHz
The results	Refer to pages*	9 - 12
Uncertainty of measurement results at Frequency		<u>±1600</u> kHz(2σ)
Uncertainty of measurement results at Amplitude		<u>± 0.6</u> dB(2σ)

**Remarks:** \*: The Page is one in the Attachment A.

---

**Peak Power Density (Sec.15.247(e))**

The requirements are	<b>● - Passed</b>	<b>○ - Not Passed</b>
Peak Peak Power Density	<u>-4.6</u> dBm at	<u>2462.0</u> MHz
The results	Refer to pages*	14 - 19
Min. limit margin	<u>12.6</u> dB at	<u>2462.0</u> MHz
Max. limit exceeding	<u>          </u> dB at	<u>          </u> MHz
Uncertainty of measurement results		<u>± 0.6</u> dB(2σ)

**Remarks:** \*: The Page is one in the Attachment A.

---

## SUMMARY

### GENERAL REMARKS :

The EUT was tested according to the requirements of FCC Rules and Regulations Part 15 Subpart A and C (Effective October 7, 2004) under the test configuration, as shown in page 24.

The conclusion for the test items of which are required by the applied regulation is indicated under the final judgement.

### FINAL JUDGEMENT :

The "as received" sample;

- - fulfill the test requirements of the regulation mentioned on page 3.
- - fulfill the test requirements of the regulation mentioned on page 3, but with certain qualifications.
- - doesn't fulfill the test regulation mentioned on page 3.

Begin of testing : October 8, 2004

End of testing : October 14, 2004

- JAPAN QUALITY ASSURANCE ORGANIZATION -

Approved by :



\_\_\_\_\_  
Akio Hosoda  
Manager  
EMC Div.  
JQA KITA-KANSAI Testing Center

Issued by :



\_\_\_\_\_  
Shigeru Kinoshita  
Deputy Manager  
EMC Div.  
JQA KITA-KANSAI Testing Center

**Test System-Arrangement (Drawings)**

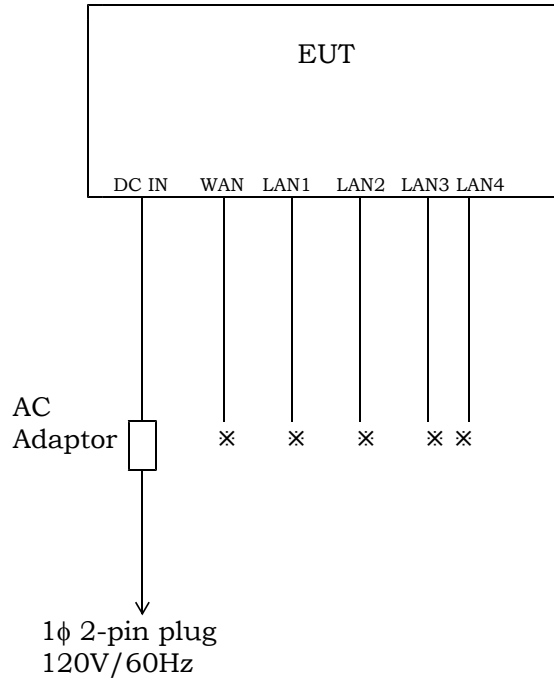

Note)  
\* : No termination

### Preliminary Test and Test-setup(Drawings)

#### AC Powerline Conducted Emission 150 kHz - 30 MHz:

The preliminary test was performed according to the description of ANSI C63.4-2003 Sec.7.2.3 (Exploratory AC Powerline Conducted Emission Measurements) and Sec.6.2.1 (Tabletop Equipment Tests).

The preliminary test was carried out to investigate the frequency of the emission that has the highest amplitude relative to the limits within normal operating modes, cable positions, and a typical system configuration. In order to find out to the maximum emission, the preliminary test and a final test were performed in accordance with the following steps.

Step 1: One operation mode of the test system was setting.

Step 2: Using both of a spectrum analyzer and a test receiver, the emission's circumstance from the system was monitored in one of ten divided frequency bands of the specified frequency range (150 kHz - 30 MHz). The maximum emission in the band was found by changing the typical cable positions or cable manipulation under a typical system configuration and by selecting of current-carrying conductor. The level and the frequency at the one point which are regarded as relative high emission in the band was measured and recorded. This step was repeated until the ending frequency band.

Step 3: Return to step 1, if the other operation mode was possible to be setting.

Step 4: Based on the collected results, the operation mode produced the maximum emission was selected. The final test on the selected operation mode was performed. But if it was difficult to select the operation mode, the final tests on all operation modes were performed.

Step 5: Based on the same data, as result if the final measurement, at the worst point that has the highest amplitude relative to the limit the repeatability of the worst was reconfirmed.

The photographs of the test system setup on the worst point were taken and recorded.

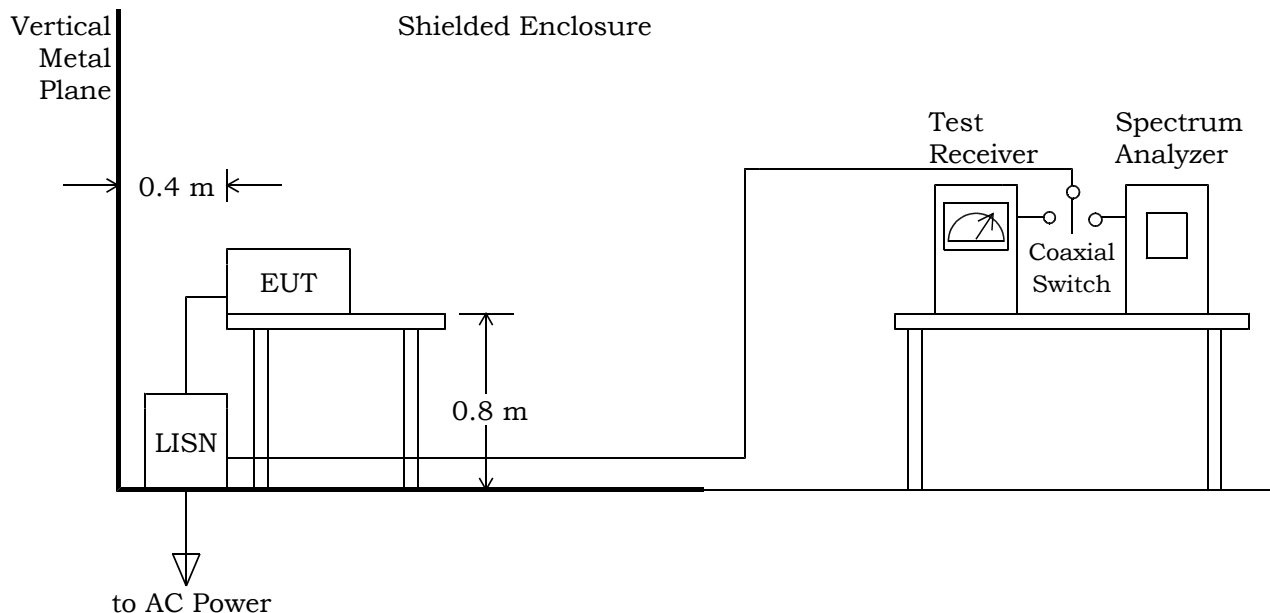

Radiated Emission (Magnetic Field) 9 kHz - 30 MHz:

The preliminary test was performed according to the description of ANSI C63.4-2003 Sec.8.3.1.1 (Exploratory Radiated Emission Measurements) and Sec.6.2.1 (Tabletop Equipment Tests).

The preliminary test was carried out to investigate the frequency of the emission that has the highest amplitude relative to the limits within normal operating modes, cable positions, and a typical system configuration. In order to find out to the maximum emission, the preliminary test and a final test were performed in accordance with the following steps.

Step 1: One operation mode of the test system was setting.

Step 2: In order to investigate the frequencies of maximum emissions, the loop antenna position was approached to the EUT and the significant frequency of the emission's circumstance from the test system were investigated. These data were recorded in the specified frequency band (9 kHz - 30 MHz).

Step 3: Using a test receiver and a loop antenna, the emission's circumstance from the test system was measured in according with ANSI C63.4-2001 Sec.8.3.1.2 (Final Radiated Emission Measurements) at each frequency which was found the higher emission referred to level vs. frequency on the list and which was measured by the loop antenna. The maximum emission was found by changing the antenna angle under a typical system configuration.

Step 4: Return to step 1, if the other operation mode was possible to be setting.

Step 5: The worst result was reported arranging data of which was obtained and performed by one or plural operation modes as the final test.

At the worst point that has the highest amplitude relative to the limit the repeatability of the level was reconfirmed. The photographs of the tests system setup on the worst point were taken and recorded.

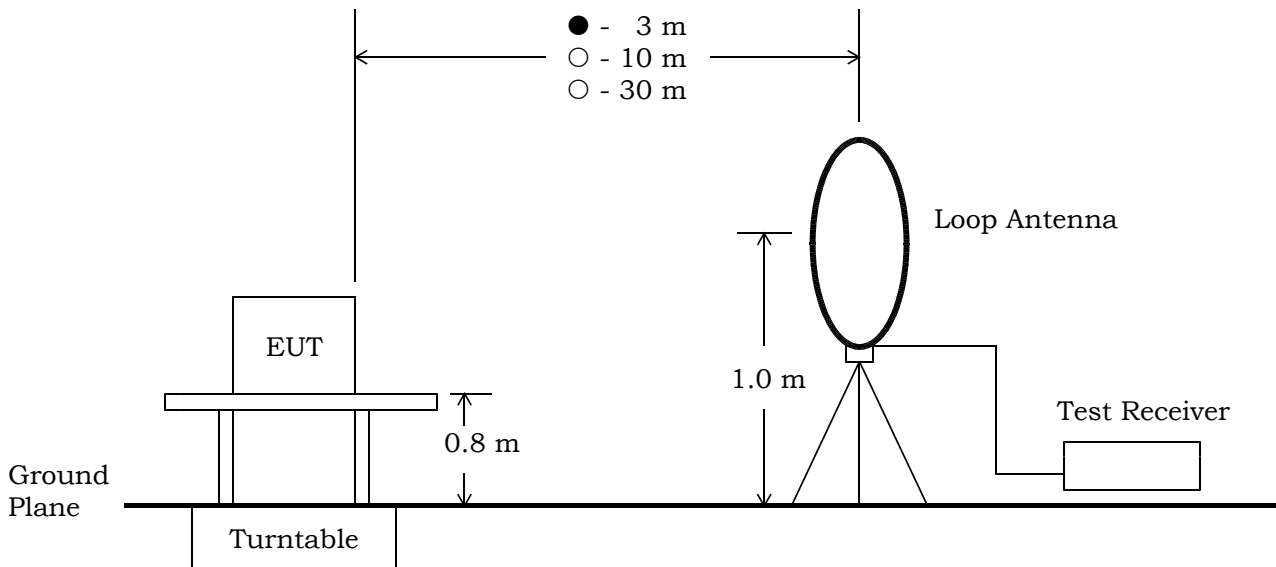

Electromagnetic Field Radiated Emission 30 MHz - 1000 MHz:

The preliminary test was performed according to the description of ANSI C63.4-2003 Sec.8.3.1.1 (Exploratory Radiated Emission Measurements) and Sec.6.2.1 (Tabletop Equipment Tests).

The preliminary test was carried out to investigate the frequency of the emission that has the highest amplitude relative to the limits within normal operating modes, cable positions, and a typical system configuration. In order to find out to the maximum emission, the preliminary test and a final test were performed in accordance with the following steps.

Step 1: One operation mode of the test system was setting.

Step 2: Using a test receiver and a test antenna probe, the significant frequency of the emission's circumstance from the test system were investigated. These data were recorded every one of 22 divided bands in the specified frequency band (30 MHz - 1000 MHz).

Step 3: Using a test receiver and a linearly polarized broadband antenna, the emission's circumstance from the test system was measured in according with ANSI C63.4-2001 Sec.8.3.1.2 (Final Radiated Emission Measurements) at each frequency which was found the higher emission referred to level vs. frequency on the list and which was measured by the linearly polarized broadband antenna. The maximum emission was found by changing the antenna angle under a typical system configuration.

Step 4: Return to step 1, if the other operation mode was possible to be setting.

Step 5: The worst result was reported arranging data of which was obtained and performed by one or plural operation modes as the final test.

At the worst point that has the highest amplitude relative to the limit the repeatability of the level was reconfirmed. The photographs of the tests system setup on the worst point were taken and recorded.

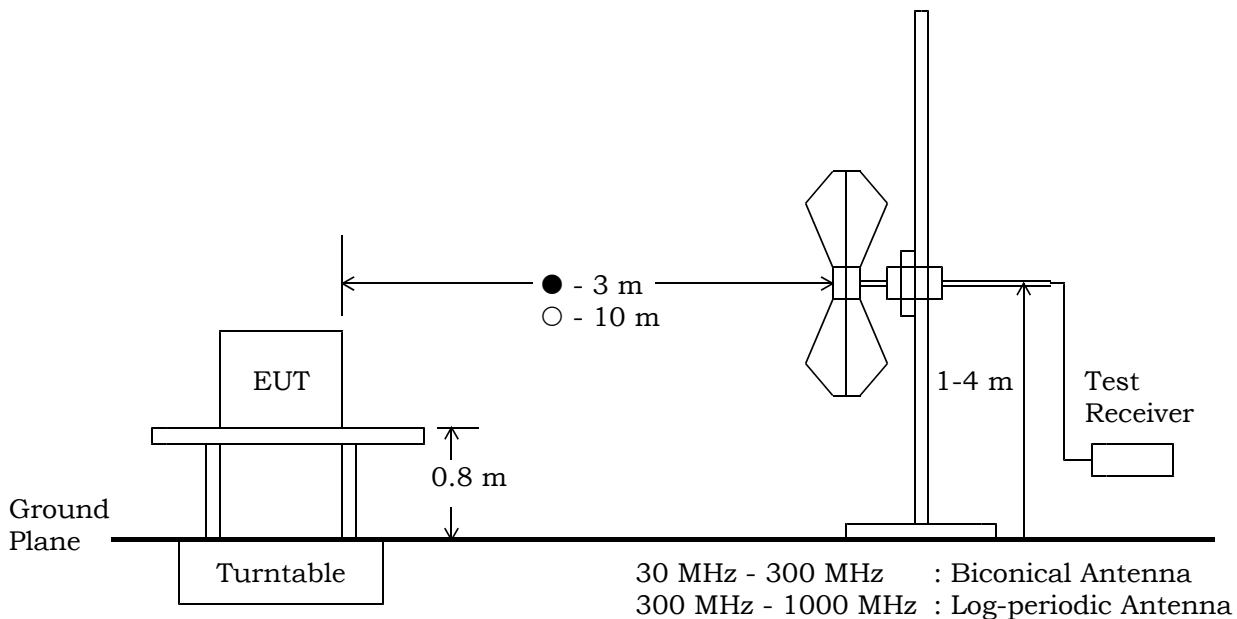

Electromagnetic Field Radiated Emission 1 GHz - 25 GHz:

The preliminary test was performed according to the description of ANSI C63.4-2003 Sec.8.3.1.1 (Exploratory Radiated Emission Measurements) and Sec.6.2.1 (Tabletop Equipment Tests).

The preliminary test was carried out to investigate the frequency of the emission that has the highest amplitude relative to the limits within normal operating modes, cable positions, and a typical system configuration. In order to find out to the maximum emission, the preliminary test and a final test were performed in accordance with the following steps.

Step 1: One operation mode of the test system was setting.

Step 2: In order to investigate the frequencies of maximum emissions, the horn antenna position was approached to the EUT and the significant frequency of the emission's circumstance from the test system were investigated. These data were recorded in the specified frequency band (1 GHz - 25 GHz).

Step 3: The emission's circumstance from the test system was measured in accordance with ANSI C63.4-2001, Sec.8.3.1.2 (Final Radiated Emissions Tests) at each frequency which was found higher emission referred to level vs. frequency on the list and which was measured in the specified distance using the horn antenna. The maximum emission was found by changing the antenna angle under a typical system configuration.

Step 4: Return to step 1, if the other operation mode was possible to be setting.

Step 5: The worst result was reported arranging data of which was obtained and performed by one or plural operation modes as the final test.

At the worst point that has the highest amplitude relative to the limit the repeatability of the level was reconfirmed. The photographs of the tests system setup on the worst point were taken and recorded.

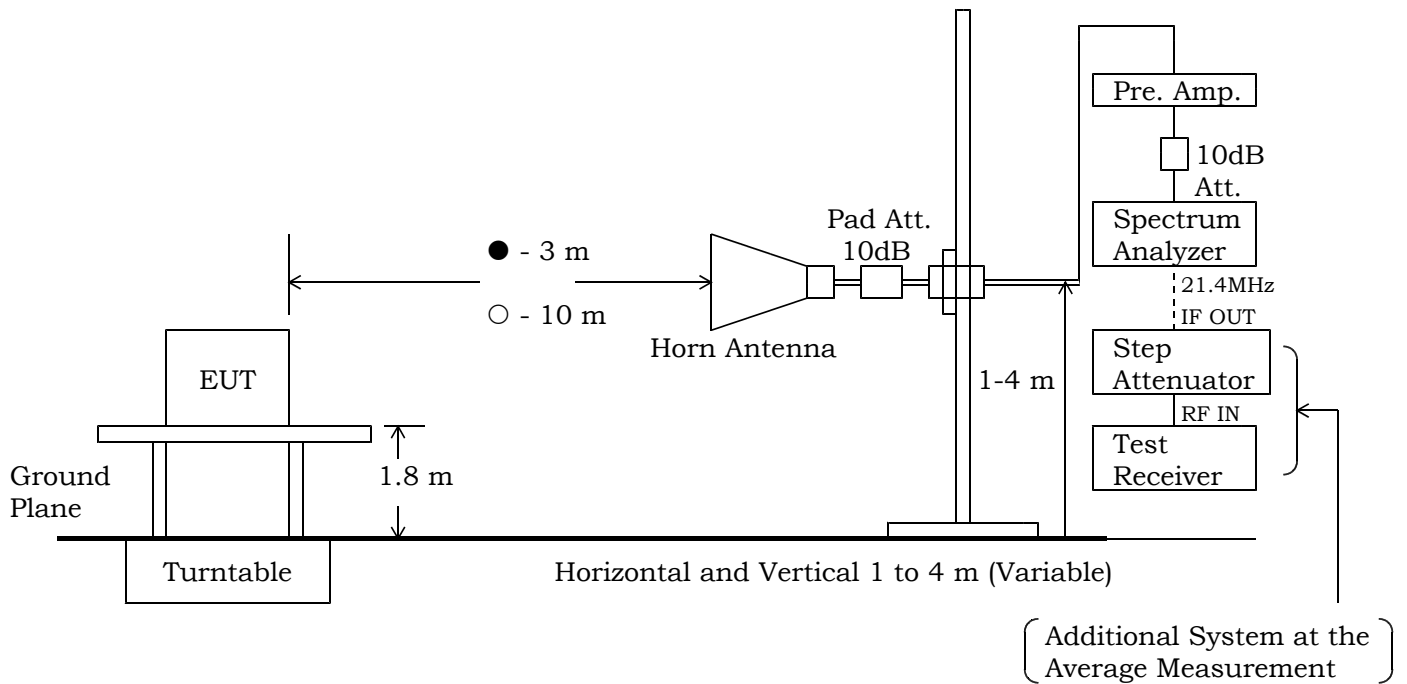

Spectrum Analyzer Setting:

Detector	*)Peak/Average
RES BW	1 MHz
VIDEO BW	1 MHz
SPAN	0 Hz

Test Receiver Setting:

SCALE	LINEAR	LINEAR
I.F.B.W.	1 MHz	1 MHz
Detector	Average	Peak

\*) For the average measurement, it is made using a test receiver and a step attenuator.

**Test-Setup (Photographs) at worst case**

Conducted Emission



Front View



Side View

Radiated Emission



Close-up

## AC Powerline Conducted Emission Measurement

Test Date: October 13, 2004

Temp.: 22 °C, Humi: 60 %

Test condition : Transmitting Frequency:2437MHz(6ch)

Frequency [MHz]	Corr. Factor [dB]	Meter Readings [dB(μV)]				Limits [dB(μV)]		Results [dB(μV)]		Margin [dB]	Remarks
		VA QP	AVE	VB QP	AVE	QP	AVE	QP	AVE		
0.20	0.2	44.0	--	43.0	--	63.5	53.5	44.2	--	+19.3	A
0.40	0.1	34.0	--	34.0	--	57.8	47.8	34.1	--	+23.7	A
0.61	0.1	34.0	--	34.0	--	56.0	46.0	34.1	--	+21.9	A
1.52	0.2	32.0	--	33.0	--	56.0	46.0	33.2	--	+22.8	A
2.83	0.3	34.0	--	34.0	--	56.0	46.0	34.3	--	+21.7	A
3.95	0.3	37.0	--	37.0	--	56.0	46.0	37.3	--	+18.7	A
4.45	0.3	36.0	--	35.0	--	56.0	46.0	36.3	--	+19.7	A
8.41	0.5	35.0	--	35.0	--	60.0	50.0	35.5	--	+24.5	A
14.38	0.6	31.0	--	31.0	--	60.0	50.0	31.6	--	+28.4	A
21.47	0.8	23.0	--	22.0	--	60.0	50.0	23.8	--	+36.2	A

Sample of calculated result at 3.95 MHz, as the Minimum Margin point:

$$\begin{array}{rcl}
 \text{Corr. Factor} & = & 0.3 \text{ dB} \\
 + ) \text{ Meter Reading} & = & 37.0 \text{ dB}(\mu\text{V}) \\
 \hline
 \text{Result} & = & 37.3 \text{ dB}(\mu\text{V})
 \end{array}$$

Minimum Margin: 56.0 - 37.3 = 18.7 (dB)

The point shown on “ \_\_\_ ” is the Minimum Margin Point.

Note: The correction factor includes the LISN insertion loss and the cable loss.

**Remarks:**

	Detector Function	IF Bandwidth
A	CISPR QP	9 kHz
B	Average	10 kHz

Tester : Yuzo Tanaka

## Electromagnetic Field Radiated Emission Measurement

Test Date: October 13, 2004  
Temp.: 22 °C, Humi: 52 %

Frequency [MHz]	Antenna Factor [dB(1/m)]	Cable Loss [dB]	Meter Readings [dB(μV)]		Limits [dB(μV/m)]	Results [dB(μV/m)]		Margin [dB]	Remarks
			Hori.	Vert.		Hori.	Vert.		
133.0	13.4	1.8	23.0	22.0	43.5	38.2	37.2	+ 5.3	A
200.0	16.8	2.2	9.0	< 12.0	43.5	28.0	< 31.0	> +12.5	A
250.0	17.2	2.4	16.0	9.0	46.0	35.6	28.6	+10.4	A
300.0	14.0	2.7	21.0	14.0	46.0	37.7	30.7	+ 8.3	A
400.0	16.3	3.2	21.0	16.0	46.0	40.5	35.5	+ 5.5	A
500.0	17.5	3.7	18.0	21.0	46.0	39.2	42.2	+ 3.8	A
560.0	18.4	3.9	13.0	9.0	46.0	35.3	31.3	+10.7	A
625.0	19.3	4.1	11.0	10.0	46.0	34.4	33.4	+11.6	A
700.0	20.3	4.4	6.0	4.0	46.0	30.7	28.7	+15.3	A
750.0	20.6	4.6	4.0	7.0	46.0	29.2	32.2	+13.8	A

Sample of calculated result at 500.0 MHz, as the Minimum Margin point:

Antenna Factor	=	17.5 dB(1/m)
Cable Loss	=	3.7 dB
+ ) Meter Reading	=	21.0 dB(μV)
Result	=	42.2 dB(μV/m)

Minimum Margin: 46.0 - 42.2 = 3.8 (dB)

The point shown on “ \_\_\_\_\_ ” is the Minimum Margin Point.

Note 1:

- 1)The highest frequency generated or used in the EUT : 2462.0 MHz
- 2)The upper frequency of measurement range : 25GHz
- 3)The spectrum was scanned 9kHz to 1GHz and all emissions not reported were more than 20dB below the applied limits.

Remarks:

Note2	Detector Function	IF Bandwidth	Antenna
A	CISPR QP	120 kHz	Broadband
B	Average	120 kHz	
C	Average	12 kHz	
D	Average	7.5 kHz	
E	CISPR QP	120 kHz	Tuned Dipole

**Electromagnetic Field Radiated Emission Measurement**  
 Intentional Radiator  
 Fundamental and Spurious (above 1 GHz )

Test Date: October 12, 2004  
 Temp.: 26 °C ; Humi.: 60 %

**a) Mode of EUT : 802.11b**  
**Transmitting Frequency : 2412MHz (1ch)**

Frequency [MHz]	Antenna Factor [dB(1/m)]	Corr. Factor [dB]	Meter Readings at 3m [dB(μV)]		Limits [dB(μV/m)]	Results at 3m [dB(μV/m)]		Margin [dB]	Remarks (Note 2)
			Hori.	Vert.		Hori.	Vert.		
<b>Fundamental</b> 2412.0	21.5	10.4	75.9	76.3	---	107.8	108.2	---	A
<b>Bnad-Edge</b>									
* 2390.0	21.5	10.4	< 20.0	< 20.0	74.0	< 51.9	< 51.9	> +22.1	E
* 2390.0	21.5	10.4	< 10.0	< 10.0	54.0	< 41.9	< 41.9	> +12.1	F
<b>Spurious at Peak Detector</b>									
* 4824.0	36.2	-21.1	< 40.0	< 40.0	74.0	< 55.1	< 55.1	> +18.9	A
7236.0	36.7	-19.6	< 40.0	< 40.0	88.2	< 57.1	< 57.1	> +31.1	A
9648.0	39.3	-27.1	< 40.0	< 40.0	88.2	< 52.2	< 52.2	> +36.0	A
* 12060.0	43.2	-26.3	< 40.0	< 40.0	74.0	< 56.9	< 56.9	> +17.1	A
* 14472.0	46.8	-26.0	< 40.0	< 40.0	74.0	< 60.8	< 60.8	> +13.2	A
16884.0	43.8	-26.4	< 40.0	< 40.0	88.2	< 57.4	< 57.4	> +30.8	A
* 19296.0	40.3	-27.8	< 40.0	< 40.0	74.0	< 52.5	< 52.5	> +21.5	A
21708.0	40.3	-27.4	< 40.0	< 40.0	88.2	< 52.9	< 52.9	> +35.3	A
24120.0	40.4	-28.3	< 40.0	< 40.0	88.2	< 52.1	< 52.1	> +36.1	A
<b>Spurious at Average Detector</b>									
* 4824.0	36.2	-21.1	< 30.0	< 30.0	54.0	< 45.1	< 45.1	> + 8.9	C
* 12060.0	43.2	-26.3	< 30.0	< 30.0	54.0	< 46.9	< 46.9	> + 7.1	C
* 14472.0	46.8	-26.0	< 30.0	< 30.0	54.0	< 50.8	< 50.8	> + 3.2	C
* 19296.0	40.3	-27.8	< 30.0	< 30.0	54.0	< 42.5	< 42.5	> +11.5	C

**a) Mode of EUT : 802.11b**  
**Transmitting Frequency : 2437MHz (6ch)**

Frequency [MHz]	Antenna Factor [dB(1/m)]	Corr. Factor [dB]	Meter Readings at 3m [dB(μV)]		Limits [dB(μV/m)]	Results at 3m [dB(μV/m)]		Margin [dB]	Remarks (Note 2)
			Hori.	Vert.		Hori.	Vert.		
<b>Fundamental</b> 2437.0	21.4	10.4	76.8	75.5	---	108.6	107.3	---	A
<b>Spurious at Peak Detector</b>									
* 4874.0	36.4	-21.3	< 40.0	< 40.0	74.0	< 55.1	< 55.1	> +18.9	A
* 7311.0	37.1	-19.5	< 40.0	< 40.0	74.0	< 57.6	< 57.6	> +16.4	A
9748.0	39.2	-27.0	< 40.0	< 40.0	88.6	< 52.2	< 52.2	> +36.4	A
* 12185.0	43.1	-26.3	< 40.0	< 40.0	74.0	< 56.8	< 56.8	> +17.2	A
14622.0	46.1	-26.0	< 40.0	< 40.0	88.6	< 60.1	< 60.1	> +28.5	A
17059.0	43.7	-26.5	< 40.0	< 40.0	88.6	< 57.2	< 57.2	> +31.4	A
* 19496.0	40.3	-27.6	< 40.0	< 40.0	74.0	< 52.7	< 52.7	> +21.3	A
21933.0	40.3	-27.7	< 40.0	< 40.0	88.6	< 52.6	< 52.6	> +36.0	A
24370.0	40.4	-28.7	< 40.0	< 40.0	88.6	< 51.7	< 51.7	> +36.9	A
<b>Spurious at Average Detector</b>									
* 4874.0	36.4	-21.3	< 30.0	< 30.0	54.0	< 45.1	< 45.1	> + 8.9	C
* 7311.0	37.1	-19.5	< 30.0	< 30.0	54.0	< 47.6	< 47.6	> + 6.4	C
* 12185.0	43.1	-26.3	< 30.0	< 30.0	54.0	< 46.8	< 46.8	> + 7.2	C
* 19496.0	40.3	-27.6	< 30.0	< 30.0	54.0	< 42.7	< 42.7	> +11.3	C

**a)Mode of EUT : 802.11b**

**Transmitting Frequency : 2462MHz (11ch)**

Frequency [MHz]	Antenna Factor [dB(1/m)]	Corr. Factor [dB]	Meter Readings at 3m [dB(μV)]		Limits [dB(μV/m)]	Results at 3m [dB(μV/m)]		Margin [dB]	Remarks (Note 2)
			Hori.	Vert.		Hori.	Vert.		
<b>Fundamental</b>									
2462.0	21.3	10.4	77.1	77.1	---	108.8	108.8	---	A
<b>Bnad-Edge</b>									
* 2483.5	21.2	10.4	< 20.0	< 20.0	74.0	< 51.6	< 51.6	> +22.4	E
* 2483.5	21.2	10.4	< 10.0	< 10.0	54.0	< 41.6	< 41.6	> +12.4	F
<b>Spurious at Peak Detector</b>									
* 4924.0	36.7	-21.4	< 40.0	< 40.0	74.0	< 55.3	< 55.3	> +18.7	A
* 7386.0	37.5	-19.4	< 40.0	< 40.0	74.0	< 58.1	< 58.1	> +15.9	A
9848.0	39.2	-27.0	< 40.0	< 40.0	88.8	< 52.2	< 52.2	> +36.6	A
* 12310.0	43.2	-26.2	< 40.0	< 40.0	74.0	< 57.0	< 57.0	> +17.0	A
14772.0	45.4	-26.1	< 40.0	< 40.0	88.8	< 59.3	< 59.3	> +29.5	A
17234.0	43.5	-26.5	< 40.0	< 40.0	88.8	< 57.0	< 57.0	> +31.8	A
* 19696.0	40.3	-27.3	< 40.0	< 40.0	74.0	< 53.0	< 53.0	> +21.0	A
* 22158.0	40.3	-27.8	< 40.0	< 40.0	74.0	< 52.5	< 52.5	> +21.5	A
24620.0	40.4	-28.9	< 40.0	< 40.0	88.8	< 51.5	< 51.5	> +37.3	A
<b>Spurious at Average Detector</b>									
* 4924.0	36.7	-21.4	< 30.0	< 30.0	54.0	< 45.3	< 45.3	> + 8.7	C
* 7386.0	37.5	-19.4	< 30.0	< 30.0	54.0	< 48.1	< 48.1	> + 5.9	C
* 12310.0	43.2	-26.2	< 30.0	< 30.0	54.0	< 47.0	< 47.0	> + 7.0	C
* 19696.0	40.3	-27.3	< 30.0	< 30.0	54.0	< 43.0	< 43.0	> +11.0	C
* 22158.0	40.3	-27.8	< 30.0	< 30.0	54.0	< 42.5	< 42.5	> +11.5	C

**b)Mode of EUT : 802.11g**

**Transmitting Frequency : 2412MHz (1ch)**

Frequency [MHz]	Antenna Factor [dB(1/m)]	Corr. Factor [dB]	Meter Readings at 3m [dB(μV)]		Limits [dB(μV/m)]	Results at 3m [dB(μV/m)]		Margin [dB]	Remarks (Note 2)
			Hori.	Vert.		Hori.	Vert.		
<b>Fundamental</b>									
2412.0	21.5	10.4	75.4	75.6	---	107.3	107.5	---	A
<b>Bnad-Edge</b>									
* 2390.0	21.5	10.4	33.0	33.0	74.0	64.9	64.9	+ 9.1	E
* 2390.0	21.5	10.4	11.0	11.0	54.0	42.9	42.9	+11.1	F
<b>Spurious at Peak Detector</b>									
* 4824.0	36.2	-21.1	< 40.0	< 40.0	74.0	< 55.1	< 55.1	> +18.9	A
7236.0	36.7	-19.6	< 40.0	< 40.0	87.5	< 57.1	< 57.1	> +30.4	A
9648.0	39.3	-27.1	< 40.0	< 40.0	87.5	< 52.2	< 52.2	> +35.3	A
* 12060.0	43.2	-26.3	< 40.0	< 40.0	74.0	< 56.9	< 56.9	> +17.1	A
* 14472.0	46.8	-26.0	< 40.0	< 40.0	74.0	< 60.8	< 60.8	> +13.2	A
16884.0	43.8	-26.4	< 40.0	< 40.0	87.5	< 57.4	< 57.4	> +30.1	A
* 19296.0	40.3	-27.8	< 40.0	< 40.0	74.0	< 52.5	< 52.5	> +21.5	A
21708.0	40.3	-27.4	< 40.0	< 40.0	87.5	< 52.9	< 52.9	> +34.6	A
24120.0	40.4	-28.3	< 40.0	< 40.0	87.5	< 52.1	< 52.1	> +35.4	A
<b>Spurious at Average Detector</b>									
* 4824.0	36.2	-21.1	< 30.0	< 30.0	54.0	< 45.1	< 45.1	> + 8.9	C
* 12060.0	43.2	-26.3	< 30.0	< 30.0	54.0	< 46.9	< 46.9	> + 7.1	C
* 14472.0	46.8	-26.0	< 30.0	< 30.0	54.0	< 50.8	< 50.8	> + 3.2	C
* 19296.0	40.3	-27.8	< 30.0	< 30.0	54.0	< 42.5	< 42.5	> +11.5	C

**b)Mode of EUT : 802.11g**

**Transmitting Frequency : 2437MHz (6ch)**

Frequency [MHz]	Antenna Factor [dB(1/m)]	Corr. Factor [dB]	Meter Readings at 3m [dB(μV)]		Limits [dB(μV/m)]	Results at 3m [dB(μV/m)]		Margin [dB]	Remarks (Note 2)
			Hori.	Vert.		Hori.	Vert.		
<b>Fundamental</b>									
2437.0	21.4	10.4	77.4	75.8	---	109.2	107.6	---	A
<b>Spurious at Peak Detector</b>									
* 4874.0	36.4	-21.3	< 40.0	< 40.0	74.0	< 55.1	< 55.1	> +18.9	A
* 7311.0	37.1	-19.5	< 40.0	< 40.0	74.0	< 57.6	< 57.6	> +16.4	A
9748.0	39.2	-27.0	< 40.0	< 40.0	89.2	< 52.2	< 52.2	> +37.0	A
* 12185.0	43.1	-26.3	< 40.0	< 40.0	74.0	< 56.8	< 56.8	> +17.2	A
14622.0	46.1	-26.0	< 40.0	< 40.0	89.2	< 60.1	< 60.1	> +29.1	A
17059.0	43.7	-26.5	< 40.0	< 40.0	89.2	< 57.2	< 57.2	> +32.0	A
* 19496.0	40.3	-27.6	< 40.0	< 40.0	74.0	< 52.7	< 52.7	> +21.3	A
21933.0	40.3	-27.7	< 40.0	< 40.0	89.2	< 52.6	< 52.6	> +36.6	A
24370.0	40.4	-28.7	< 40.0	< 40.0	89.2	< 51.7	< 51.7	> +37.5	A
<b>Spurious at Average Detector</b>									
* 4874.0	36.4	-21.3	< 30.0	< 30.0	54.0	< 45.1	< 45.1	> + 8.9	C
* 7311.0	37.1	-19.5	< 30.0	< 30.0	54.0	< 47.6	< 47.6	> + 6.4	C
* 12185.0	43.1	-26.3	< 30.0	< 30.0	54.0	< 46.8	< 46.8	> + 7.2	C
* 19496.0	40.3	-27.6	< 30.0	< 30.0	54.0	< 42.7	< 42.7	> +11.3	C

**b) Mode of EUT : 802.11g**  
**Transmitting Frequency : 2462MHz (11ch)**

Frequency [MHz]	Antenna Factor [dB(1/m)]	Corr. Factor [dB]	Meter Readings at 3m [dB(μV)]		Limits [dB(μV/m)]	Results at 3m [dB(μV/m)]		Margin [dB]	Remarks (Note 2)
			Hori.	Vert.		Hori.	Vert.		
<b>Fundamental</b> 2462.0	21.3	10.4	76.7	75.0	---	108.4	106.7	---	A
<b>Bnad-Edge</b>									
* 2483.5	21.2	10.4	33.0	30.0	74.0	64.6	61.6	+ 9.4	E
* 2483.5	21.2	10.4	< 10.0	< 10.0	54.0	< 41.6	< 41.6	> +12.4	F
<b>Spurious at Peak Detector</b>									
* 4924.0	36.7	-21.4	< 40.0	< 40.0	74.0	< 55.3	< 55.3	> +18.7	A
* 7386.0	37.5	-19.4	< 40.0	< 40.0	74.0	< 58.1	< 58.1	> +15.9	A
9848.0	39.2	-27.0	< 40.0	< 40.0	88.4	< 52.2	< 52.2	> +36.2	A
* 12310.0	43.2	-26.2	< 40.0	< 40.0	74.0	< 57.0	< 57.0	> +17.0	A
14772.0	45.4	-26.1	< 40.0	< 40.0	88.4	< 59.3	< 59.3	> +29.1	A
17234.0	43.5	-26.5	< 40.0	< 40.0	88.4	< 57.0	< 57.0	> +31.4	A
* 19696.0	40.3	-27.3	< 40.0	< 40.0	74.0	< 53.0	< 53.0	> +21.0	A
* 22158.0	40.3	-27.8	< 40.0	< 40.0	74.0	< 52.5	< 52.5	> +21.5	A
24620.0	40.4	-28.9	< 40.0	< 40.0	88.4	< 51.5	< 51.5	> +36.9	A
<b>Spurious at Average Detector</b>									
* 4924.0	36.7	-21.4	< 30.0	< 30.0	54.0	< 45.3	< 45.3	> + 8.7	C
* 7386.0	37.5	-19.4	< 30.0	< 30.0	54.0	< 48.1	< 48.1	> + 5.9	C
* 12310.0	43.2	-26.2	< 30.0	< 30.0	54.0	< 47.0	< 47.0	> + 7.0	C
* 19696.0	40.3	-27.3	< 30.0	< 30.0	54.0	< 43.0	< 43.0	> +11.0	C
* 22158.0	40.3	-27.8	< 30.0	< 30.0	54.0	< 42.5	< 42.5	> +11.5	C

Sample of calculated result at 14472.0 MHz, as the Minimum Margin point:

Antenna Factor = 46.8 dB(1/m)  
 Corr. Factor = -26.0 dB  
 +) Meter Reading = <30.0 dB(μV)  
 Result = <50.8 dB(μV/m)

Minimum Margin : 54.0 - <50.8 = >3.2(dB)

The point shown on “\_\_\_\_\_” is the Minimum Margin Point.

Note 1:

- 1)The highest frequency generated or used in the EUT: 2462 MHz
- 2)The upper frequency of measurement range : 25 GHz
- 3)The spectrum was scanned 1 GHz to 25 GHz and all emissions not reported were more than 20 dB below the applied limits.
- 4)Symbol '\*': Restricted bands of operation in Sec.15.205.
- 5)Corr. Factor (Fundamental) = Cable Loss + 10 dB Pad Attenuator [dB]  
 Corr. Factor (≤ 7.6 GHz) = Cable Loss + 20 dB Pad Attenuator  
 Corr. Factor (7.6 GHz ≤ F ≤ 18 GHz) = Cable Loss + 10 dB Pad Attenuator- Amp. Gain [dB]  
 Corr. Factor (≥ 18 GHz) = Cable Loss - Amp. Gain + Mixer Conversion Loss(atIF=8GHz)[dB]

**Remarks:**

Note 2	Detector Function	RES. B.W.	V.B.W.	Sweep T	Span
A	Peak (SP)	1 MHz	1 MHz	20 msec	0 Hz
B	Peak (SP)	100 kHz	300 kHz	20 msec	0 Hz
*) C	Average (Receiver)	1 MHz (1 MHz)	3 MHz	20 msec	0 Hz
D	Peak	1 MHz	3 MHz	20 msec	0 Hz
E	Peak (Receiver)	1 MHz	--	--	--
F	Average (Receiver)	1 MHz	--	--	--

( ):Setting of spectrum analyzer

\*)For the average/peak measurement method, it is made measurement using a test receiver, a step attenuator or and a spectrum analyzer(FCC REPLY No. 950523A).

Tester : Shigeru Kinoshita

## Maximum Peak Power (EIRP) Measurement Fundamental Emission

Test Date: October 12, 2004  
 Temp.: 26 °C ; Humi.: 60 %

### Measurement Results:

a) Mode of EUT : 801.11b

#### 1) Emission Measurement in Fig.1(a)

CH	Frequency [MHz]	Meter Reading [dBuV]		Remarks (Note 1)
		Horizontal Mh	Vertical Mv	
1	2412.0	75.9	76.3	A
6	2437.0	76.8	75.5	A
11	2462.0	77.1	77.1	A

#### 2) Substitution Measurement in Fig.1(b)

CH	Frequency [MHz]	Meter Reading [dBuV]		Supplied Power to Substitution Antenna [dBm] Ps	Gain of Substitution Antenna [dBi] Gs
		Horizontal Msh	Vertical Msv		
1	2412.0	77.7	77.7	-1.3	16.5
6	2437.0	77.9	77.8	-1.3	16.6
11	2462.0	78.2	78.2	-1.2	16.7

#### 3) Calculated Result

CH	Frequency [MHz]	Peak EIRP [dBm]		Maximum Peak EIRP [mW]
		Horizontal EIRPh	Vertical EIRPv	
1	2412.0	13.4	13.8	24.0
6	2437.0	14.2	13.0	26.3
11	2462.0	14.4	14.4	27.5

Sample of calculated result at 2462.0 MHz, as the Minimum Margin point:

$$\begin{aligned}
 &\text{Meter Reading Mh in Fig.1(a)} &= & 77.1 \text{ dB}(\mu\text{V}) \\
 &\text{Meter Reading -Msh in Fig.1(b)} &= & -78.2 \text{ dB}(\mu\text{V}) \\
 &\text{Supplied Power to Sub. Ant.} &= & -1.2 \text{ dB} \\
 &\text{+) Gain of Sub. Ant.} &= & 16.7 \text{ dB} \\
 &\text{Result} &= & 14.4 \text{ dBm} \\
 &\text{Peak EIRP} &= & 14.4 \text{ dBm} \quad ; 10^{(14.4/10)} = 27.5 \text{ (mW)}
 \end{aligned}$$

$$\text{EIRPh} = \text{Mh} - \text{Msh} + \text{Ps} + \text{Gs}$$

$$\text{EIRPv} = \text{Mv} - \text{Msv} + \text{Ps} + \text{Gs}$$

The point shown on "\_\_\_" is the Maximum Point.

#### Remarks:

Note 1	Detector Function	RES. B.W.	V.B.W.	Sweep T	Span
A	Peak (SP)	1 MHz	3 MHz	20 msec	0 Hz

Tester : Shigeru Kinoshita

## Maximum Peak Power (EIRP) Measurement Fundamental Emission

Test Date: October 12, 2004  
 Temp.: 26 °C ; Humi.: 60 %

### Measurement Results:

**b) Mode of EUT : 801.11g**

**1) Emission Measurement in Fig.1(a)**

CH	Frequency [MHz]	Meter Reading [dBuV]		Remarks (Note 1)
		Horizontal Mh	Vertical Mv	
		1	2412.0	
6	2437.0	77.4	75.8	A
11	2462.0	76.7	75.0	A

**2) Substitution Measurement in Fig.1(b)**

CH	Frequency [MHz]	Meter Reading [dBuV]		Supplied Power to	Gain of
		Horizontal Msh	Vertical Msv	Substitution Antenna	Substitution Antenna
				[dBm]	[dBi]
1	2412.0	77.7	77.7	Ps	Gs
6	2437.0	77.9	77.8	-1.3	16.5
11	2462.0	78.2	78.2	-1.3	16.6
				-1.2	16.7

**3) Calculated Result**

CH	Frequency [MHz]	Peak EIRP [dBm]		Maximum
		Horizontal EIRPh	Vertical EIRPv	Peak EIRP
				[mW]
1	2412.0	12.9	13.1	20.4
6	2437.0	14.8	13.3	30.2
11	2462.0	14.0	12.3	25.1

Sample of calculated result at 2437.0 MHz, as the Minimum Margin point:

$$\begin{aligned}
 &\text{Meter Reading Mh in Fig.1(a)} &&= 77.4 \text{ dB}(\mu\text{V}) \\
 &\text{Meter Reading -Msh in Fig.1(b)} &&= -77.9 \text{ dB}(\mu\text{V}) \\
 &\text{Supplied Power to Sub. Ant.} &&= -1.3 \text{ dB} \\
 &\text{+) Gain of Sub. Ant.} &&= 16.6 \text{ dB} \\
 &\text{Result} &&= 14.8 \text{ dBm} \\
 &\text{Peak EIRP} &= 14.8 \text{ dBm} &: 10^{(14.8/10)} = 30.2 \text{ (mW)}
 \end{aligned}$$

$$\text{EIRPh} = \text{Mh} - \text{Msh} + \text{Ps} + \text{Gs}$$

$$\text{EIRPv} = \text{Mv} - \text{Msv} + \text{Ps} + \text{Gs}$$

The point shown on " \_\_\_ " is the Maximum Point.

**Remarks:**

Note 1	Detector Function	RES. B.W.	V.B.W.	Sweep T	Span
A	Peak (SP)	1 MHz	3 MHz	20 msec	0 Hz

Tester : Shigeru Kinoshita

### Transmitter Power(TP) Measurement

Test Date: October 14, 2004  
 Temp.: 24 °C ; Humi.: 60 %

Measurement Results:

**a)Mode of EUT : 801.11b**

**A)Supply Voltage : 102V**

**Mode of EUT : 801.11b**

CH	Frequency [MHz]	Correction Factor [dB]	Meter Reading Peak [dBm]	Results Peak [dBm]	[mW]	Limits [dBm]	Margin [dB]
1	2412.0	10.9	1.3	12.2	16.6	30.0	+17.8
6	2437.0	10.9	1.4	12.3	17.0	30.0	+17.7
11	2462.0	10.9	1.2	12.1	16.2	30.0	+17.9

**B)Supply Voltage : 120V**

**Mode of EUT : 801.11b**

CH	Frequency [MHz]	Correction Factor [dB]	Meter Reading Peak [dBm]	Results Peak [dBm]	[mW]	Limits [dBm]	Margin [dB]
1	2412.0	10.9	1.3	12.2	16.6	30.0	+17.8
6	2437.0	10.9	1.4	12.3	17.0	30.0	+17.7
11	2462.0	10.9	1.2	12.1	16.2	30.0	+17.9

**C)Supply Voltage : 138V**

**Mode of EUT : 801.11b**

CH	Frequency [MHz]	Correction Factor [dB]	Meter Reading Peak [dBm]	Results Peak [dBm]	[mW]	Limits [dBm]	Margin [dB]
1	2412.0	10.9	1.3	12.2	16.6	30.0	+17.8
6	2437.0	10.9	1.4	12.3	17.0	30.0	+17.7
11	2462.0	10.9	1.2	12.1	16.2	30.0	+17.9

**b)Mode of EUT : 801.11g**

**A)Supply Voltage : 102V**

**Mode of EUT : 801.11g**

CH	Frequency [MHz]	Correction Factor [dB]	Meter Reading Peak [dBm]	Results Peak [dBm]	[mW]	Limits [dBm]	Margin [dB]
1	2412.0	10.9	1.6	12.5	17.8	30.0	+17.5
6	2437.0	10.9	1.6	12.5	17.8	30.0	+17.5
11	2462.0	10.9	1.6	12.5	17.8	30.0	+17.5

**B)Supply Voltage : 120V**

**Mode of EUT : 801.11g**

CH	Frequency [MHz]	Correction Factor [dB]	Meter Reading Peak [dBm]	Results Peak [dBm]	[mW]	Limits [dBm]	Margin [dB]
1	2412.0	10.9	1.6	12.5	17.8	30.0	+17.5
6	2437.0	10.9	1.6	12.5	17.8	30.0	+17.5
11	2462.0	10.9	1.6	12.5	17.8	30.0	+17.5

**C)Supply Voltage : 138V**

**Mode of EUT : 801.11g**

CH	Frequency [MHz]	Correction Factor [dB]	Meter Reading Peak [dBm]	Results Peak [dBm]	[mW]	Limits [dBm]	Margin [dB]
1	2412.0	10.9	1.6	12.5	17.8	30.0	+17.5
6	2437.0	10.9	1.6	12.5	17.8	30.0	+17.5
11	2462.0	10.9	1.6	12.5	17.8	30.0	+17.5

Sample of calculated result at 2412.0MHz, as the Minimum Margin point:

$$\begin{array}{rcl}
 \text{Correction Factor} & = & 10.9 \text{ dB} \\
 +) \text{ Meter Reading} & = & 1.6 \text{ dBm} \\
 \hline
 \text{Result} & = & 12.5 \text{ dBm} \quad ; 10^{(12.5/10)} = 17.8(\text{mW})
 \end{array}$$

Minimum Margin : 30.0 - 12.5 = 17.5(dB)

The point shown on “ \_\_\_\_\_ ” is the Minimum Margin Point.

- Note : 1. The correction factor includes the attenuator loss and the cable loss.  
 2. The Video Bandwidth of the Peak Power Analyzer is set to 150MHz.

Tester : Shigeru Kinoshita

### Calculated Antenna gain of the EUT

Calculated Results:

Antenna gain of the integrated antenna of the EUT :  $G_{\text{eut}}$  (dB)  
 Transmitter power (Measured) : TP (dBm)  
 EIRP (Measured) : EIRP (dBm)

If the antenna gain ( $G_{\text{EUT}}$ ) is met the equations as follows.

$$\text{EIRP} = \text{TP} \times G_{\text{eut}}$$

$$G_{\text{EUT}} (\text{Numeric}) = \text{EIRP} / \text{TP}$$

$$G_{\text{EUT}} (\text{dB}) = 10\log_{10}(\text{EIRP} / \text{TP})$$

**a) Mode of EUT : 801.11b**

CH	Frequency [MHz]	Maximum Peak EIRP [mW]	TP [mW]	Geut [dBi]
1	2412.0	24.0	16.6	1.6
6	2437.0	26.3	17.0	1.9
11	2462.0	27.5	16.2	2.3

**b) Mode of EUT : 801.11g**

CH	Frequency [MHz]	Maximum Peak EIRP [mW]	TP [mW]	Geut [dBi]
1	2412.0	20.4	17.8	0.6
6	2437.0	30.2	17.8	2.3
11	2462.0	25.1	17.8	1.5

Sample of calculated result at 2462.0 MHz, as the Maximum point:

EIRP	=	14.4 dBm = $10\log_{10}(27.5)$
-) TP	=	12.1 dBm = $10\log_{10}(16.2)$
Result	=	2.3 dBi

The point shown on “\_\_\_\_\_” is the Maximum Point.

### 6dB Bandwidth Measurement

Test Date: October 8, 2004  
 Temp.: 24 °C ; Humi.: 60 %

a) Mode of EUT : 802.11b

CH No.	Transmitting Frequency(MHz)	6dB Bandwidth	99% Bandwidth	Data Page*
1	2412.0	11.84 MHz	15.51 MHz	Page 2
6	2437.0	11.41 MHz	15.48 MHz	Page 3
11	2462.0	11.80 MHz	15.42 MHz	Page 4

b) Mode of EUT : 802.11g

CH No.	Transmitting Frequency(MHz)	6dB Bandwidth	99% Bandwidth	Data Page*
1	2412.0	16.69 MHz	16.65 MHz	Page 5
6	2437.0	16.65 MHz	16.62 MHz	Page 6
11	2462.0	16.69 MHz	16.62 MHz	Page 7

- Note) 1. \*: The Data Page is one in Attachment A.  
 2. The point shown on " \_\_\_\_\_ " is the Maximum Margin Point.

Tester : Shigeru Kinoshita

### Band-Edge Emission Measurement

Test Date: October 8, 2004  
 Temp.: 24 °C ; Humi.: 60 %

a) Mode of EUT : 802.11b

1) Low Band-Edge Measurement

CH	Transmitting Frequency(MHz)	Band-Edge Frequency(MHz)	Band-Edge Level[dBc]	Data Page*
1	2412.0	2400.0	-37.0	Page 9

2) High Band-Edge Measurement

CH	Transmitting Frequency(MHz)	Band-Edge Frequency(MHz)	Band-Edge Level[dBc]	Data Page*
11	2462.0	2483.5	-39.4	Page 10

b) Mode of EUT : 802.11g

1) Low Band-Edge Measurement

CH	Transmitting Frequency(MHz)	Band-Edge Frequency(MHz)	Band-Edge Level[dBc]	Data Page*
1	2412.0	2400.0	-28.4	Page 11

2) High Band-Edge Measurement

CH	Transmitting Frequency(MHz)	Band-Edge Frequency(MHz)	Band-Edge Level[dBc]	Data Page*
11	2462.0	2483.5	-33.9	Page 12

Note) 1. \*: The Data Page is one in Attachment A.  
 2. The point shown on " \_\_\_\_\_ " is the Maximum Point.

Tester : Shigeru Kinoshita

**Peak Power Density Measurement  
 Fundamental Emission**

Test Date: October 8, 2004  
 Temp.: 24 °C ; Humi.: 60 %

**a) Mode of EUT : 801.11b**

CH	Frequency [MHz]	Correction Factor [dB]	Meter Reading Peak [dBm]	Peak Power [dBm]	Limits [dBm]	Margin [dB]	Data Page*
1	2412.0	21.9	-27.2	-5.3	8.0	+13.3	Page 14
6	2437.0	21.9	-26.6	-4.7	8.0	+12.7	Page 15
11	2462.0	21.9	-26.5	-4.6	8.0	+12.6	Page 16

**b) Mode of EUT : 801.11g**

CH	Frequency [MHz]	Correction Factor [dB]	Meter Reading Peak [dBm]	Peak Power [dBm]	Limits [dBm]	Margin [dB]	Data Page*
1	2412.0	21.9	-34.3	-12.4	8.0	+20.4	Page 17
6	2437.0	21.9	-33.8	-11.9	8.0	+19.9	Page 18
11	2462.0	21.9	-34.0	-12.1	8.0	+20.1	Page 19

Note) 1. The Data Page is one Attachment A.

Sample of calculated result at 2462.0 MHz, as the Minimum Margin point:

$$\begin{array}{rcl}
 \text{Corr. Factor} & = & 21.9 \text{ dB} \\
 +) \text{ Meter Reading} & = & -26.5 \text{ dBm} \\
 \hline
 \text{Result} & = & -4.6 \text{ dBm}
 \end{array}$$

Minimum Margin :  $8.0 - (-4.6) = 12.6(\text{dB})$

The point shown on “    ” is the Minimum Margin Point.