

FVD99-F011

FCC ID: ACJ93312140

Operating Instructions

Mode d'emploi

Manual de Instrucciones

Multi-Scan Color Monitor

*PanaSync*TM S110i

MODEL TX-D1F64MA

Designed for



Microsoft®
Windows®98

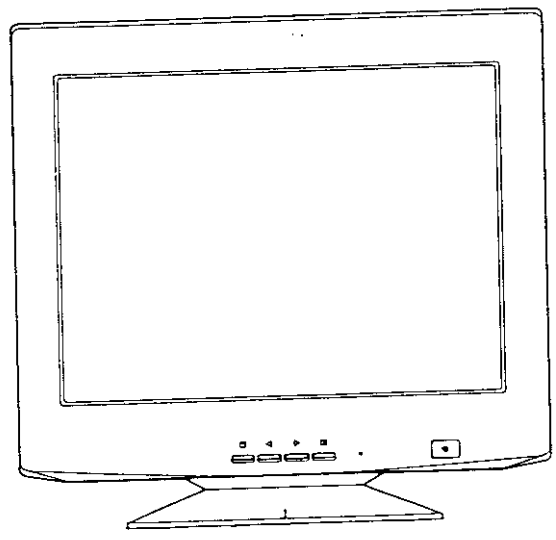

Panasonic®

These Operating Instructions are for units for sale and use in the United States of America and Canada only. Read these Instructions completely before operating this display monitor.

FCC ID: A0593312140

FVD99-F011

ENGLISH

IMPORTANT NOTICE CONCERNING POWER CORD SELECTION

The power cord set for this unit has been enclosed and has been selected according to the country of destination and must be used to prevent electric shock. Use the following guidelines if it is necessary to replace the original cord set, or if the cord set is not enclosed.

The female receptacle of the cord set must meet CEE-22 requirements and will look like Figure 1:

For the United States and Canada:

In the United States and Canada the male plug is a NEMA 5-15 style (Figure 2) and is UL listed and CSA labelled. For units which are mounted on a desk or table, type SVT or SJT cord sets may be used. For units which sit on the floor, only SJT type cord sets may be used. The cord set must be selected according to the current rating for your unit. Please consult Table A for the selection criteria for power cords used in the United States and Canada. (The cord set is marked with its Cord Type.)

For European Countries:

In Europe you must use a cord set which is appropriate for the receptacles in your country. The cord set is HAR-Certified, and the mark ◀HAR▶ will appear on the outer sheath, or on the insulation of one of the inner conductors.

If you have any questions concerning the proper power cord to use, please consult the dealer from whom you have purchased your unit.

Table A

Cord Type	Size of Conductors in Cord	Maximum Current Rating of Unit
SJT	18 AWG	10 Amps
	16 AWG	12 Amps
	14 AWG	12 Amps
SVT	18 AWG	10 Amps
	17 AWG	12 Amps



Figure 1

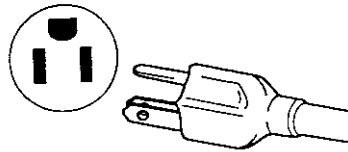

Figure 2

Federal Communications Commission Requirements

This equipment has been tested and found to comply with the limits for Class B digital devices, pursuant to Part 15 of the FCC Rules. These limits are designed to provide reasonable protection against harmful interference in a residential installation. This equipment generates, uses, and can radiate radio frequency energy and, if not installed and used in accordance with the instructions, may cause harmful interference to radio communications. However, there is no guarantee that interference will not occur in a particular installation. If this equipment does cause harmful interference to radio or television reception, which can be determined by turning the equipment off and on, the user is encouraged to try to correct the interference by one or more of the following measures:

- Reorient or relocate the receiving antenna.
- Increase the separation between the equipment and receiver.
- Connect the equipment into an outlet on a circuit different from that to which the receiver is connected.
- Consult the dealer or an experienced radio / TV technician for help.

This device complies with Part 15 of the FCC Rules. Operation is subject to the following two conditions: (1) This device may not cause harmful interference, and (2) this device must accept any interference received, including interference that may cause undesired operation.

FCC Warning:

To assure continued FCC compliance, the user must use the provided grounded power supply cord and shielded interface cable with bonded ferrite cores. If BNC cable is going to be used, use only shielded BNC (5) cable. Also, any unauthorized changes or modifications to this monitor would void the user's authority to operate this device.

NOTE FCC Class B Complied : Up to Mode 1,600 x 1,200 at 110 kHz max. and 1,800 x 1,440 at 105 kHz max. Horizontal frequency.

CE Conformity



This device complies with the requirements of the EEC directive 89 / 336 / EEC as amended by 92 / 31 / EEC and 93 / 68 / EEC Art. 5 with regard to "Electromagnetic compatibility" and 73 / 23 / EEC as amended by 93 / 68 / EEC Art. 13 with regard to "Safety".

Required item	Relative to Standard Value	Relative to those Exceeding Standard Value	Remarks
EMI	#1	-	#4
ESD	#2	#3	--
RADIATED RF	#1	#3	--
TRANSIENT F / B	#1	#3	--
LINE HARMONICS	#1	-	--

- #1 : Satisfies standards with no problems in performance and reliability.
 - #2 : Effects may appear temporarily on the screen but there will be no problem in reliability.
 - #3 : There is fear of the product breaking down.
 - #4 : If a signal cable other than that specified is used, it may be the cause of electromagnetic interference to peripheral devices.
- To assure continued CE compliance the user must use the provided 1.5 m shielded video signal cable with bonded ferrite cores at both ends of the cable.

Handle correctly in accordance with the instruction manual.

EMI : Electromagnetic Interference

ESD : Electrostatic Discharge

RF : Radio Frequency

F / B : Fast Burst

ENERGY STAR®

As an ENERGY STAR® partner, Panasonic Document Imaging Company has determined that this product meets the ENERGY STAR® guidelines for energy efficiency.

Notice for Germany

NOTE:

- For ergonomic reasons, it is recommend not to use blue characters on a dark background. Doing so may produce insufficient contrast that could lead to eye strain.
- The sound pressure level at the operator's position according to IEC 704 - 1 : 1982 is equal or less than 70 dB (A).

German

HINWEIS:

- Aus ergonomischen Gründen wird empfohlen, die Grundfarbe Blau nicht auf dunklem Untergrund zu verwenden (schlechte Erkennbarkeit, Augenbelastung bei zu geringem Zeichenkontrast wäre die Folge).
- Der Arbeitsplatzbezogene Schalldruckpegel nach DIN 45 635 beträgt 70 dB (A) oder weniger.

Notice for Japan

This is a Class B product based on the standard of the Voluntary Control Council for Interference from Information Technology Equipment (VCCI). If this is used near a radio or television receiver in a domestic environment, it may cause radio interference. Install and use the equipment according to the instruction manual.

Japanese

この装置は、情報処理装置等電波障害自主規制協議会（VCCI）の基準に基づくクラスB情報技術装置です。この装置は、家庭環境で使用することを目的としていますが、この装置がラジオやテレビジョン受信機に近接して使用されると、受信障害を引き起こすことがあります。
取扱説明書に従って正しい取り扱いをして下さい。



Danger

To avoid the risk of severe electrical shock including death, do not remove covers (or back) of monitor. No user serviceable parts are inside. Refer servicing to qualified service personnel.



Warnings

To prevent risk of electric shock and possible fire:

Never place any object on the monitor, AC Power cord, or cause the cords to make sharp bends, or otherwise do anything that can affect the integrity of the cords. Always remove the line cord from the socket by holding the plug, not the cord.

Do not place anything containing any liquid (even a wet or damp cloth) on the monitor as the introduction of fluids can create an electrical hazard. Do not expose the monitor to rain or moisture.

Do not place the monitor with less than the recommended clearance (see Precautions, 1 Installation Page 4). Do not block the ventilation openings with anything. Do not insert any objects into the ventilation openings.

Customer's Record

The serial number of this product is printed on its back cover label. Note this serial number in the space provided and retain this booklet as a permanent record of your purchase to aid in identification of the unit in the event of theft or loss.

Model number: TX-D1F64MA

Serial number: _____

Table of Contents

IMPORTANT NOTICE CONCERNING POWER CORD SELECTION	1
Federal Communications Commission Requirements	1
CE Conformity	2
ENERGY STAR®	2
Notice for Germany	2
Notice for Japan	2
Danger	3
Warnings	3
Customer's Record	3
Table of Contents	3
Precautions 1) Installation	4
Precautions 2) Usage	4
Precautions 3) Product Care	4
Features	5
Specifications	6
Installation	7
Pin Assignment	8
External View	8
Operation	9
Operation procedure	9
Adjustments	10
Power Management System	14
Memories	14
Timing Specifications	15
Trouble Shooting	16
Technical Support	16

Precautions

1) Installation

- Install the monitor in a well ventilated place. Avoid exposing to direct sunlight, a heater, or any other heat source. Heat will adversely affect the cabinets and the parts inside.
- Position the display unit so that the holes in the cabinet will not be blocked during use.
- Keep the display unit away from the kitchen, bathroom, washing machine, or other sources of exposed to water, steam or moisture.
- In order to use the display unit safely, use only the supplied AC Power cord. The AC Power cord must be used with a properly grounded and polarized power supply socket. The AC Power cord supplied is for the USA (UL) and Canada (CSA) for use with the display unit. For use in other countries, make sure the AC Power cord meets the safety standards of the country.
- Place the AC Power cord where it will not be subject to stress.
- Use only Panasonic provided accessories or the exact equivalent.

2) Usage

- Pulling on the AC Power cord or VGA Signal Cable can damage the display unit (monitor) and can cause the unit to fall and possibly cause personal injury.
- Receiving trouble.
If there is a television set or other display unit nearby, keep your display unit as far away from it as possible. Mutual interference can cause image distortion or noise.
- Long exposure to rubber or vinyl products can stain the cabinet.
- Keep the monitor from physical shock when moving. Be careful of the Cathode Ray Tube (CRT).
- Do not place anything on the monitor.
- Also take good care of the AC Power cord:
Do not place any objects on the AC Power cord. Do not attempt to extend, shorten or tie it into a knot.

3) Product Care

- Prior to cleaning your display unit, disconnect the AC Power cord and the VGA Signal Cable or BNC Cable from the display unit.
- Use a clean, soft, dry cloth to clean the outside of the monitor or the CRT surface.
If the monitor or CRT surface is very dirty, wet a clean, soft cloth with neutral detergent (such as dishwashing detergent) and water, squeeze it tight until almost dry, wipe the monitor or CRT surface with it, and finish by wiping with a clean dry cloth. Do not use any solvents.
- Do not rub or strike the monitor with anything hard or harsh as this may scratch, mar or damage the monitor permanently.
- Do not use a chemical duster or polish-cleaner because it can adversely affect the unit and peel the paint coat.

Features

1) High Image Quality in a Package

- The S110i with a CRT 21" (20.0" / 50.8 cm Viewable (Image Size) has image quality that has to be seen to be believed. It has a 0.25 mm ultra fine dot pitch and up to 1,600 × 1,200 at 85 Hz / 1,800 dots (H) × 1,440 lines (V) at 70 Hz maximum resolution. The S110i produces sharp saturated color images with High Contrast and Brightness that can be viewed over a wide viewing angle.
- Combined with optimized dynamic focusing circuitry, the CRT has improved beam landing accuracy, focus, convergence and lower raster distortion than a typical 21-inch CRT. This gives the S110i a sharper, more uniform focus, especially in the corners of the screen, traditionally a focus problem area. Crystal Pigment Phosphors and Advanced Invar Mask provide increased Contrast and Brightness.
- The S110i digital multi-scan 30 kHz to 110 kHz* Horizontal and 50 Hz to 180 Hz Vertical scanning frequencies can be automatically scanned. Eight timing selections have been preset at the factory and 20 user programmable selections are provided.

2) Crystal Pigment Phosphors

- Crystal Pigment Phosphors provide increased brightness and contrast for the S110i creating crisp colorful images. Each grain of Crystal Pigment Phosphor is covered with a filter material of the same color to filter external light.

3) Advanced INVAR Shadow Mask and Dark tint

- The CRT also features an Advanced INVAR Shadow Mask, which is manufactured with an improved material and designed to be positioned closer to the screen-glass. When combined with the Dark tint of the screen, this results in a 10% overall increase in brightness, improved purity due to less environmental movement, and better overall color uniformity.

4) New DQ-DAF™ Electron Gun with Super New OLF

- The new DQ-DAF (Double-Quadruple Dynamic Astigmatism and Focus) electron gun reduces the degradation of the screen focus, realizing higher resolution. In addition, the super new OLF (Overlapping Field) main lens for the S110i creates a smaller spot size which contributes to sharper images.

5) Digital adjustment using on-screen Menu (OSM)

- The On-Screen Menu is available in five (5) languages. English, French, German, Italian or Spanish can be selected. Custom adjustments can be made quickly and easily through the On-Screen Menu utilizing four buttons on the front panel. The On-Screen Menu may be positioned in one of six locations and color in one of six colors on the Display Screen. A Self-Test On-Screen display is provided with no signal input or an Error On-Screen Menu if the Horizontal or Vertical Scanning frequencies are outside the specified range.

6) The S110i is Plug & Play

- VESA® DDC™ 1 / 2 B compatible (Video Electronics Standards Association Display Data Channel). This allows the S110i to inform a compatible host of its capabilities that meet the Microsoft® / Intel® Plug & Play Definition used by Windows® 95 and Windows® 98.

7) Self-test menu

- The display unit can be checked via the self-test menu displayed on the screen. This menu can be accessed without a computer.

8) Environmentally Friendly

- The S110i has a VESA® DPMS™ power management circuit. When used with a DPMS™ compatible graphics card, the power consumption of the S110i can be reduced. This product conforms to the ENERGY STAR® program.
- All plastic parts are recyclable.
- Meets MPR II, TCO'92 and carries the CE mark.

9) Color Adjusting Function





- The White Reference Color Temperature is 9300 K + 8 MPCD, 7500 K, 6500 K, 5000 K, 9300 K + 27 MPCD or User Color which can be selected to adjust the red, green and blue signals of the monitor to match its image to the output of a color printer.

10) Ergonomic Design

- Tilt & Swivel base with 90-degree pan to right or left and tilt angle of 13 degrees up a 3 degrees down.
- Advanced Anti-Glare, anti-Reflection, and Anti-Static screen coating.

- * FCC Class B Complied : Up to Mode 1,600 × 1,200 at 110 kHz max. and 1,800 × 1,440 at 105 kHz max. Horizontal frequency.

Specifications

CRT	Size	21" CRT (20.0" / 50.8 cm Viewable Image Size) Flat Square	
	Dot-pitch	0.25 mm (Horizontal : 0.217mm / Vertical : 0.132mm)	
	Phosphor / Glass	RGB medium short persistence (Hi-EU RED), Crystal Pigment / Dark tint	
	Surface treatment	B-AGRAS (Anti-Glare, anti-Reflective and Anti-Static) Coat	
Input signals	Video signaling	RGB analog	
	Signal level	0.7 Vp-p (without sync. signal), 1.0 Vp-p (with sync. signal)	
	Sync. signal	H / V separation (TTL level), H / V composition (TTL level), Sync.-on-green	
	Frequency Range	Horizontal Frequency : 30.0 kHz to 110.0 kHz*	
		Vertical Frequency : 50.0 Hz to 180.0 Hz	
Preset mode	1 preset and 7 reservation (See page 15)		
Video	Maximum Pixel Clock	230.0 MHz (typ.)	
Resolution		1,600 dots (H) x 1,200 lines (V) at 85 Hz / 1,800 dots (H) x 1,440 lines (V) at 70 Hz*	
Viewable Image Size (H x V, Diagonal)	Factory preset	15.59" x 11.69", 19.5" Diagonal **	
	Full scan (Typical)	15.98" x 11.97", 20.0" Diagonal **	
	Display Color	Analog input, unlimited number of colors ***	
Connectors	Video Signal	15 pin mini D-Sub connector (female pins), BNC x 5	
	Power supply	CEE-22 type 3-pin connector	
Input power		100 to 240 V AC (50 or 60Hz)	
Power consumption		145 W typ. / < 10 W stand-by, < 3 W sleep mode (See page 14)	
Controls	Front	Power ON / OFF,  ,  ,  ,  keys	
	On screen display	Contrast, Brightness, Size & Pos. (Zoom, H. Position, H. Size, V. Position, V. Size), Geometry (V. Pincushion, Side Pin. Bal., Trapezoid, Parallelogram, Top Corner, Bottom Corner, S-Curve 1, S-Curve 2), Rotation (Tilt), Color Temp. (9300 K + 8 MPCD, 7500 K, 6500 K, 5000 K, 9300 K + 27 MPCD, User), Recall, Video Level (0.7 V / 1 V), H. Moire, V. Moire, H. Convergence, V. Convergence, Linearity-C, Linearity-E, Language, OSD Position, Degauss, Signal, Self-Test menu	
Tilt / swivel		13° up, 3° down, 90° each to right and left	
Dimensions (W x H x D)		19.6" x 18.8" x 19.5" (498 mm x 477.5 mm x 494.5 mm)	
Weight (monitor only)		27.0 kg (59.5 lbs)	
Approvals		UL1950, CSA 22.2 No.950, TÜV / GS, CE / CISPR 22-B (EN55022), NORDIC, FCC Class B, DHHS, HC, IC-B, VCCI Class B, MPR II, TCO'92, ENERGY STAR®, ISO 9241-3 (Ergonomics) / -8 (Colors)	
Standard		1 detachable signal cable for VGA, SVGA 1 detachable AC power supply cord Tilt & Swivel base attached Operating Instructions, Warranty card	
Environmental conditions	Operating	Temperature	5 to 35 °C (41 to 95 °F)
		Humidity	5 to 90% (no condensation)
		Altitude	10,000 ft
	Storage	Temperature	-20 to +60 °C (-4 to 140 °F)
	Humidity	5 to 90% (no condensation)	
	Altitude	40,000 ft	
Windows® 95 / 98 Plug & Play		VESA® DDC™ 1 / 2B meets Windows® 95 / 98 Plug & Play Requirements	

Note:

- The on-screen image may flicker if the display is operated with the Vertical freq. under 60 Hz.
- FCC Class B Complied : Up to Mode 1,600 x 1,200 at 110 kHz max. and 1,800 x 1,440 at 105 kHz max. Horizontal frequency.
- ** Depends on signal timing used, see page 15.
- *** Number of colors depends on the Video Board used, memory installed, and RAMDAC (Random Access Memory Digital to Analog Converter).

Specifications and design are subject to change without notice.
This product may be subject to export control regulations.

Weight and dimensions shown are approximate.

Installation

◆ Connecting Procedures

Turn off your computer.
 Connect the signal and power connectors as shown below.
 Turn the monitor on, then turn on the computer.

A. IBM PS / 2 or PC / AT compatible models

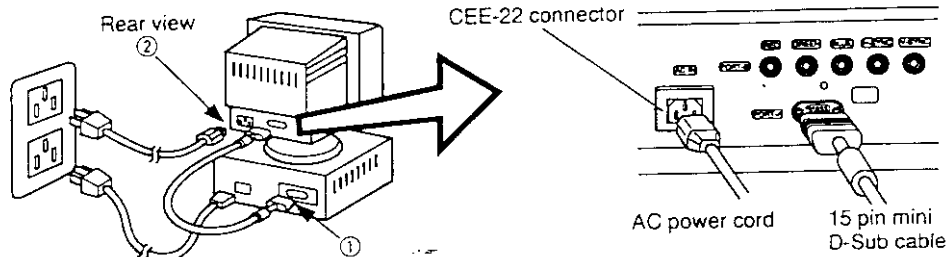

- ① Connect the supplied 15 pin mini D-Sub cable to the monitor's Port A.
 Then connect the other end of the supplied 15 pin mini D-Sub cable to the computer's corresponding 15 pin mini D-Sub video connector.
- ② First connect the supplied AC power cord to the CEE-22 connector on the rear of the monitor.
 Then connect the other end of the AC power cord to a grounded power outlet.

B. Apple computer

- ① Connect the supplied 15 pin mini D-Sub cable to the monitor's Port A.
 Then connect the other end of the supplied 15 pin mini D-Sub cable to a UNIMAC-82D MAC adapter and the other end of the MAC adapter the computers to the computer's corresponding 15 pin mini D-Sub video connector.
- ② First connect the supplied AC power cord to the CEE-22 connector on the rear of the monitor. Then connect the other end of the AC power cord to a grounded power outlet.

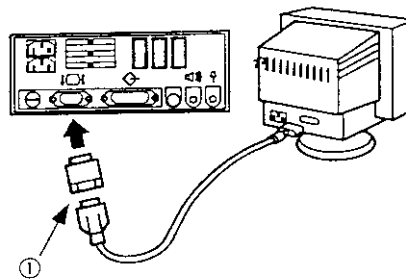

Panasonic MAC adapter
 If your need an adapter and one is not provided by your dealer, call 1-800 PANASYS (1-800-726-2797).

Caution:
 To prevent the cable from coming loose, the cable connectors must be securely fastened with screws.

C. BNC connector signal computer

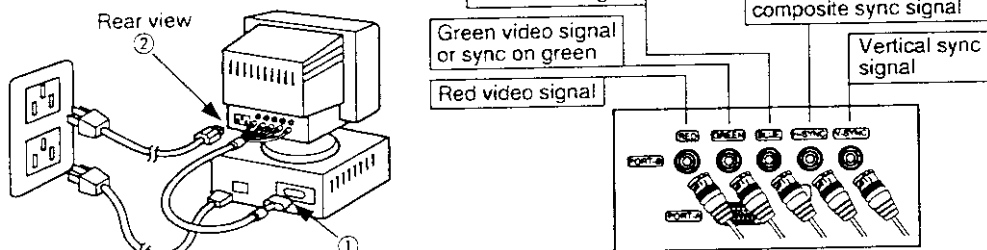

- ① Connect the BNC signal cable (Not supplied) BNC connectors to the monitor's Port B.
 Then connect the other end of the BNC cable, usually a 15 pin mini D-Sub connector, to the computer's corresponding 15 pin mini D-Sub video connector.
- ② First connect the supplied AC power cord to the CEE-22 connector on the rear of the monitor.
 Then connect the other end of the AC power cord to a grounded power outlet.

◆ Connection of AC Power Supply

If the AC power supply voltage is in the range 100 to 240 V, either 50 Hz or 60 Hz frequency can be used.
 There is no AC 100 V / 240 V selector switch as selection is automatic.

Precaution:

- In order to use the display unit safely, use a power cord that is properly grounded.
 - AC plug cords for the following countries must be used as follows:

U.S.A	UL	Canada	CSA
-------	-------	----	--------	-------	-----
- For use in other countries, make sure that the AC cord meets the safety standards of each country.

Pin Assignment

Follow the instructions below to connect the S1101 to a computer.

- A. **Signal connector:** 15 pin mini D-Sub (PS / 2 or PC / AT compatible model)
Connect the signal cable to the 15 pin mini D-Sub connector on the display unit.
- B. **Signal connector:** 15 pin D-Sub (Apple computer)
Convert a MAC 15 pin D-Sub connector to a 15 pin mini D-Sub connector using a Panasonic MAC adapter, and connect it to the 15 pin mini D-Sub connector on the display unit.

< REAR PANEL >

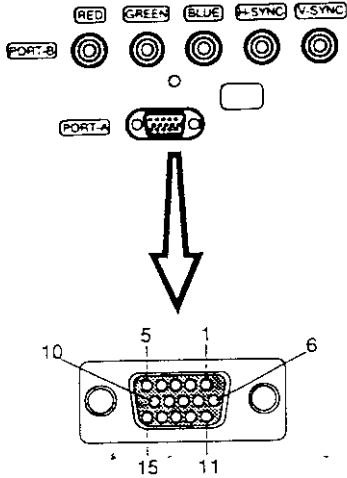

Pin assignments of 15 pin mini D-Sub connector

Pin number	Signal name
1	Red video signal
2	Green video signal
3	Blue video signal
4	Ground
5	Ground*
6	Ground for Red video signal
7	Ground for Green video signal
8	Ground for Blue video signal
9	Unused
10	Ground
11	Ground
12	SDA* (Bi-directional Data)
13	Horizontal sync. signal
14	Vertical sync. signal
15	SCL* (Data Clock)

*: "VESA's Display Data Channel (DDC) Standard"

C. **Signal connector:** BNC connector

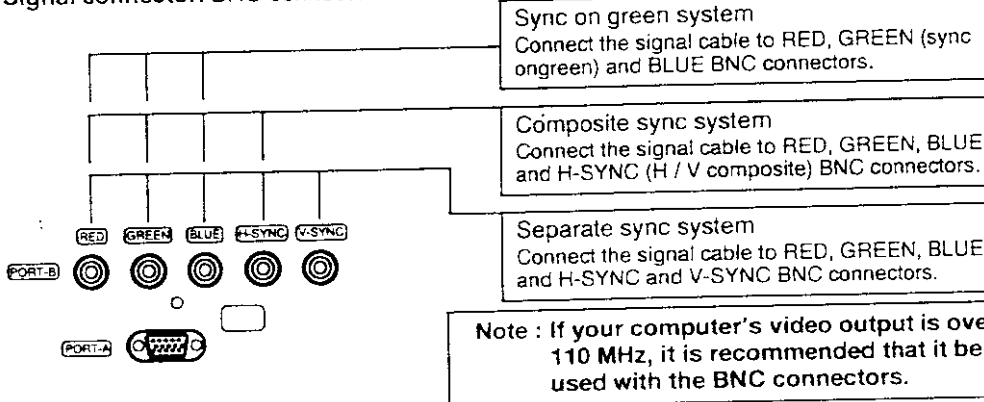

External View

Dimensions

- Width : 498 mm (19.6")
- Height : 477.5 mm (18.8")
- Depth : 494.5 mm (19.5")
- Base diameter : ϕ 300 mm (ϕ 11.8")
- Height without stand : 432.5 mm (17.0")

Pan / Tilt range

- Up : 13 degrees
- Down : 3 degrees
- Left, right : 90 degrees each

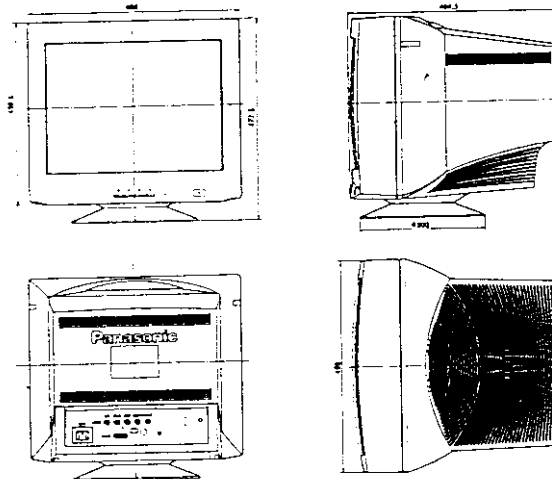

Operation

Basic operation

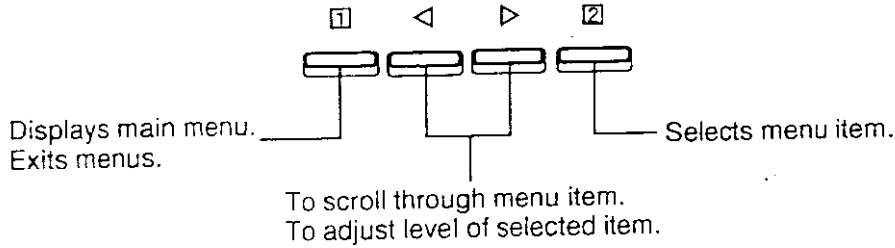

Menu screen

The functions that can be adjusted for this unit are displayed as icons.

- 1) Press the **1** key to return to the menu screen.
- 2) This is modified by pressing the **3** and **4** keys at the front.
- 3) Press the **2** key to enter the adjustment screen.

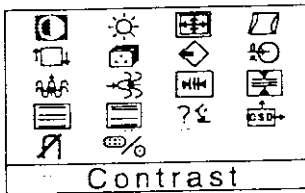

Contrast	Brightness	Size & Pos.	Geometry
Rotation	Color Temp	Recall	Video Level
H. Moire	V. Moire	H.Convergence	V.Convergence
Linearity-C	Linearity-E	Language	OSD Position
Degauss	Signal		

Operation procedure

Horizontal position adjustment

1. Press the **1** key to display the menu.

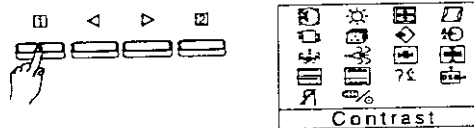

2. Press the **3** key to select the Size & Pos. from the menu screen.
Press the **2** key to display the menu.

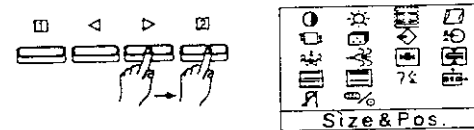

3. Press the **2** key to select the H. Position.

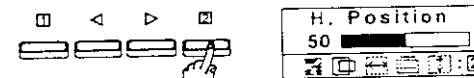

4. Press the front **3** or **4** keys to reach the desired condition.

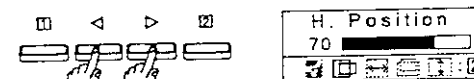



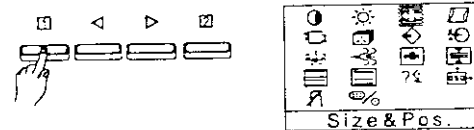













































5. Press the **1** key to save the settings to memory and complete the adjustments. Press the **1** key once more to clear the menu screen.



Adjustments

Adjustments menu

-  **Contrast** : Adjust the screen contrast to match the brightness level in the room.
 Pressing the  key toggles between brightness and contrast.
Direct operation
 Even if the menu screen does not appear, the contrast can be adjusted by pressing the  or  key. If the  and  keys are pressed at the same time, the maximum level (100) will be set.
-  **Brightness** : Adjust the brightness to match the brightness level in the room so that the level will be easy to see.
 Pressing the  key toggles between contrast and brightness.
 Note: If the  and  keys are pressed at the same time on the Brightness adjustment screen, the standard level (50) will be set.
-  **Size & Pos.** : Press the  key to select the zoom / horizontal position / horizontal size / vertical position / vertical size adjustments.
 Press the  key to save the adjustment.
 -  **Zoom** : Both the horizontal and vertical size of the image can be adjusted at the same time; however, the aspect ratio cannot be changed.
 Press the  key to make the image smaller, the  key to make it larger.
 -  **H. Position** : The horizontal position of the image can be adjusted.
 Press the  key to move it to the left, the  key to move it to the right.
 -  **H. Size** : The horizontal size of the image can be adjusted.
 Press the  key to make the image smaller, the  key to make it larger.
 Note: Setting the image in the center of the screen to start will make the adjustment easier.
 -  **V. Position** : The vertical position of the image can be adjusted.
 Press the  key to make it downward, the  key to move it upward.
 -  **V. Size** : The vertical size of the image can be adjusted.
 Press the  key to make the image smaller, the  key to make it larger.
 Note: Setting the image in the center of the screen to start will make the adjustment easier.
-  **Geometry** : Press the  key to select the vertical pincushion / side pincushion balance / trapezoid / parallelogram / Geometry 2 adjustments.
 Press the  key to save the adjustment.
 -  **V. Pincushion** : The image can be corrected for barrel distortion.
 Press the  key to decrease the Pin / Barrel distortion of the image, the  key to increase it.
 -  **Side Pin. Bal.** : It is possible to adjust the side pincushion balance to the left and right.
 Press the  key to expand to the left of the image, the  key to expand it to the right.
 -  **Trapezoid** : The image can be corrected for trapezoidal distortion.
 Press the  key to make the top edge narrower, the  key to make the bottom edge narrower.
 -  **Parallelogram** : The image can be corrected for parallelogram distortion.
 Press the  key to collapse the parallelogram to the left, the  key to collapse it to the right.
 -  **Geometry 2** : Press the  key to change the sub OSD screen.
 Press the  key to select the Top Corner / Bottom Corner / S-Curve 1 / S-Curve 2 adjustments.
 -  **Top Corner** : The image can be corrected for vertical pincushion distortion in the top corner.
 -  **Bottom Corner** : The image can be corrected for vertical pincushion distortion in the bottom corner.
 - S1 S-Curve 1** : The image can be corrected for vertical pincushion distortion in the S-Curve 1.

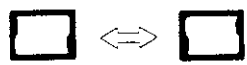

 - S2 S-Curve 2** : The image can be corrected for vertical pincushion distortion in the S-Curve 2.







Adjustments (Continued)

Adjustments menu



 **Rotation** : This control adjusts the evenness of the screen image relative to a horizontal line.

Note: If the  and  keys are pressed at the same time, the standard level (50) will be set.



 **Color Temp** : It is possible to switch the whiteness of the image.

- 1) Press the  and  keys to select 1 (9300 K + 8 MPCD) / 2 (7500 K) / 3 (6500 K) / 4 (5000 K) / 5 (9300 K + 27 MPCD) / 6 (User).
- 2)  will be displayed at the bottom right-hand side of the on-screen panel when 6 (User color) has been selected. Press the  key on the front operation area to enter the User color adjustment screen.

User : It is possible to adjust the whiteness of the image to suit personal preference.

- 1) Select R (red), G (green), B (blue) with the  key.
 - 2) Adjust the color to match personal preference with  and  keys.
- * As user colors cannot be recalled, take note of the set values beforehand.

 **Recall** : It is possible to return to the initial settings (the settings at the time of factory shipment).

- 1) When the  key (Yes) is pressed, the settings are recalled and the menu screen returns. (Recall = return to initial settings (settings at time of factory shipment))
- 2) When the  key (No) is pressed, the menu screen returns without the settings being recalled. (The settings return to what they were immediately before the recall.)

If there are no operations performed for about 30 seconds, the screen goes off without a recall.

 **Video Level** : The video input signal level can be matched to the computer being used.



Either 0.7 V or 1.0 V can be selected with the  (0.7 V / 1 V) key.

Use 0.7 V under normal condition.



Moire reduction : Moire patterns are caused by interference of the CRT dot pitch and video signal due to the resolution of the input signal, video pattern, etc., producing patterns of horizontal stripes (Horizontal moire pattern) or vertical stripes (Vertical moire pattern).



Caution:

If the moire reduction is overcorrected, the picture quality (for example focus, vertical line stability, etc.) will sometimes be affected.
Keep this adjustment within the range in which the picture quality is not affected.



 **H. Moire** : The moire correction circuit can be switched On and Off with the  key.

When the moire correction circuit is switched On with the  (On / Off) key, the adjustment screen menu appears.

Adjust with the  and  keys so that the striped moire pattern is in its optimum condition.

 **V. Moire** : The moire correction circuit can be switched On and Off with the  key.

When the moire correction circuit is switched On with the  (On / Off) key, the adjustment screen menu appears.





Adjust with the  and  keys so that the striped moire pattern is in its optimum condition.



Adjustments (Continued)





Adjustments menu



Convergence : Convergence is affected by geomagnetism. Use this function when convergence error occurs after moving the monitor or changing the screen angle.







These convergence adjustments should be made after monitor operation has stabilized.







 **H.Convergence** : Horizontal convergence of the image (color fringing) can be adjusted. Press  key to toggle between H.Convergence and V.Convergence.
Note: If the  and  keys are pressed at the same time on the H.Convergence adjustment screen, the standard level (50) will be set.



Press the  key to move red to the right and blue to the left.
Press the  key to move red to the left and blue to the right.





 **V.Convergence** : Vertical convergence of the image (color fringing) can be adjusted. Press  key to toggle between V.Convergence and H.Convergence.
Note: If the  and  keys are pressed at the same time on the V.Convergence adjustment screen, the standard level (50) will be set.

Press the  key to move red downwards and blue upwards.
Press the  key to move red upwards and blue downwards.

 **Linearity-C** : The image can be adjusted for vertical linearity in the center. Press  key toggle between Linearity-C and Linearity-E.
Note: If the  and  keys are pressed at the same time on the Linearity-C adjustment screen, the standard level will be set.
Press the  key to make the center linearity narrower.
Press the  key to make the center linearity wider.

 **Linearity-E** : The image can be adjusted for vertical linearity in the edge. Press  key toggle between Linearity-E and Linearity-C.
Note: If the  and  keys are pressed at the same time on the Linearity-E adjustment screen, the standard level will be set.
Press the  key to make the bottom linearity wider.
Press the  key to make the top linearity wider.





 **Language** : The language of the On-Screen Display can be selected from among German, French, English, Italian and Spanish.
Select with the  or  key.

 **OSD Position** : It is possible to adjust the position and color that the on-screen panel is to be displayed. The panel will rotate in a counter-clockwis direction every time the  key is pressed.
The screen color layout can be changed by holding down the  key and pressing the  key.
Six different color layouts are available.

 **Degauss** : Use this function to reduce the irregular colors in the image. The degaussing operates for approximately five seconds after selection.
Use this function when irregular colors occur in the image after moving the monitor or the changing the screen angle.
Note: Be informed that a continued use of this function cannot result in a satisfactory effect. (Try to keep an interval of about 30 minutes or so between operations.)

Adjustments (Continued)

Adjustments menu

 Signal : Use the  and  keys to select either the rear panel input terminal port A (Mini D-Sub type) or Port B (BNC) type.
 This displays the input synchronization signal frequency.
 Information on the input screen mode (resolution, horizontal and vertical synchronization frequency) will be displayed on the display monitor. There are occasions sometimes when some screen modes in use do not display any resolution. Direct display allows this to be displayed on screen by pressing the  key even when the menu screen is not displayed.

Self-Test menu (No Signal screen)

This display indicates that the monitor is operating normally. When one of the following conditions occurs, press one of the 4 operation keys to call the appropriate display.

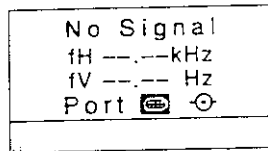

No signal (the computer is not connected, the mains power to the computer is disconnected or the input connector in use may be deselected, see Page 13 Signal for instructions.)

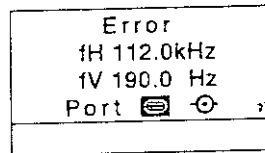

The horizontal or vertical sync. signal are outside of the permitted range (the value of the horizontal sync. signal will be displayed in red and the value of the vertical sync. signal will be displayed in white.)

Power Management System

This monitor conforms to the VESA® DPMS™ standard. This function can suppress power consumption for the display unit. The computer and video board being used must also conform to the VESA® DPMS™ standard. * Consult the Operation Manuals for the hardware being used.

Modes change in response to input signals as indicated in the table below.

APM state	Screen status	LED color	Power consumption	Recovery time	Input signals		
					Video	Horizontal	Vertical
ON STATE	Active	Green	Normal	-	ON	ON	ON
STAND-BY	Black out	Yellow	< 10 Watts	< 3 sec.	OFF	OFF	ON
SUSPEND	Black out	Yellow	< 10 Watts	< 3 sec.	OFF	ON	OFF
OFF STATE	Black out	Yellow	< 3 Watts	< 20 sec.	OFF	OFF	OFF

APM : Advanced Power Management

Caution

- Turn the monitor off when it is not to be used for a long time.
- How to release the system from the power management function
 - 1) Read the Operation Manuals for the hardware you are using.
 - 2) Press one of the [1], [2], [3] keys on the front panel.

The No Signal screen appears, and the monitor side power management function is released (only in OFF STATE).

Memories

This display has two types of memory to store the data sets that control the on-screen image. The first type of memory is the Preset Memory which is set by the factory. The second type is the User Memory which is set by the user. Both memories store the Horizontal Size, Vertical Size, Horizontal Position, Vertical Position, Vertical Pincushion, Side Pincushion Balance, Trapezoid, Parallelogram, Top Corner, Bottom Corner, S-Curve 1, S-Curve 2, Video Level, Horizontal Moire, Vertical Moire, Linearity-C and Linearity-E adjustments of the displayed image.

Preset Memory

There are 1 preset (7 reservation) timings that are set by the factory. The preset timing will automatically size and center the image with video boards which use these timings. Please see page 15 for Timing Specifications.

User Memory

- There are 20 memory locations that allow for user timing. The image size, position, geometric distortion are adjusted by the user.
- If the User Memory is completely full, and a new set of data is saved, the oldest data set in the User Memory will be deleted.
- The User Memory has priority over the Preset Memory.
- When the user timing is input, the Vertical, Horizontal frequencies and sync polarities of the signal are compared with the previous data stored in memory. The input signal will be stored as a new data set if one of its parameters is different from the previous stored one.
- The new input signal must have a frequency difference greater than that shown in the table below or a different sync. polarity from that already stored. If the new timing data includes frequency changes greater than those shown in the table below or sync. polarity changes, a new user memory setting will be stored. If the frequency difference is smaller than that of the chart and the sync. polarities are the same, the existing settings will be retained.

Horizontal frequency	Vertical frequency
Low 30 kHz ± 0.2 kHz to Hi 110 kHz ± 0.7 kHz	Low 50 Hz ± 0.3 Hz to Hi 180 Hz ± 1.1 Hz

Please note if the timing does not meet the display specifications, the size and position adjustment may not appear as desired. Be sure the horizontal and vertical timing are within the monitor specification range. See page 15 for Timing Specifications, preset and reservation timing.

Timing Specifications

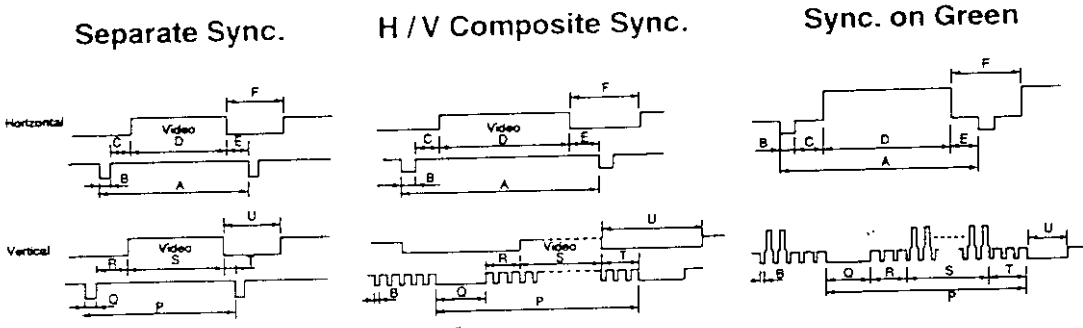

		Preset timing*	Reservation timing**		
		VESA1600x1200@85Hz	VGA640x480@60Hz	VESA800x600@85Hz	VESA1024x768@85Hz
Dot clock		229.5000 MHz	25.1750 MHz	56.2500 MHz	94.5000 MHz
fH		106.250 kHz	31.469 kHz	53.674 kHz	68.677 kHz
Horizontal	A H-Period	9.412 us (2160 dots)	31.778 us (800 dots)	18.631 us (1048 dots)	14.561 us (1376 dots)
	F H-Blanking	2.440 us (560 dots)	6.356 us (160 dots)	4.409 us (248 dots)	3.725 us (352 dots)
	B H-Sync. width	0.837 us (192 dots)	3.813 us (96 dots)	1.138 us (64 dots)	1.016 us (96 dots)
	C H-Back porch	1.325 us (304 dots)	1.907 us (48 dots)	2.702 us (152 dots)	2.201 us (208 dots)
	D H-Active	6.972 us (1600 dots)	25.422 us (640 dots)	14.222 us (800 dots)	10.836 us (1024 dots)
E H-Front porch	0.279 us (64 dots)	0.636 us (16 dots)	0.569 us (32 dots)	0.508 us (48 dots)	
fV		85.000 Hz	59.940 Hz	85.081 Hz	84.997 Hz
Vertical	P V-Period	11.765 ms (1250 lines)	16.683 ms (525 lines)	11.756 ms (631 lines)	11.765 ms (808 lines)
	U V-Blanking	0.471 ms (50 lines)	1.430 ms (45 lines)	0.578 ms (31 lines)	0.582 ms (40 lines)
	Q V-Sync. width	0.028 ms (3 lines)	0.064 ms (2 lines)	0.056 ms (3 lines)	0.044 ms (3 lines)
	R V-Back porch	0.433 ms (46 lines)	1.049 ms (33 lines)	0.503 ms (27 lines)	0.524 ms (36 lines)
	S V-Active	11.294 ms (1200 lines)	15.253 ms (480 lines)	11.179 ms (600 lines)	11.183 ms (768 lines)
T V-Front porch	0.009 ms (1 line)	0.318 ms (10 lines)	0.019 ms (1 line)	0.015 ms (1 line)	
Sync polarity (H / V)		Positive / Positive	Negative / Negative	Positive / Positive	Positive / Positive
		Reservation timing**			
		MAC 1152x870 @75Hz***	VESA1280x1024 @75Hz	VESA1280x1024 @85Hz	VESA1600x1200 @75Hz
Dot clock		100.0000 MHz	135.0000 MHz	157.5000 MHz	202.5000 MHz
fH		68.681 kHz	79.976 kHz	91.146 kHz	93.750 kHz
Horizontal	A H-Period	14.560 us (1456 dots)	12.504 us (1688 dots)	10.971 us (1728 dots)	10.667 us (2160 dots)
	F H-Blanking	3.040 us (304 dots)	3.022 us (408 dots)	2.844 us (448 dots)	2.765 us (560 dots)
	B H-Sync. width	1.280 us (128 dots)	1.067 us (144 dots)	1.016 us (160 dots)	0.948 us (192 dots)
	C H-Back porch	1.440 us (144 dots)	1.837 us (248 dots)	1.422 us (224 dots)	1.501 us (304 dots)
	D H-Active	11.520 us (1152 dots)	9.481 us (1280 dots)	8.127 us (1280 dots)	7.901 us (1600 dots)
E H-Front porch	0.320 us (32 dots)	0.119 us (16 dots)	0.406 us (64 dots)	0.316 us (64 dots)	
fV		75.061 Hz	75.025 Hz	85.024 Hz	75.000 Hz
Vertical	P V-Period	13.322 ms (915 lines)	13.329 ms (1066 lines)	11.761 ms (1072 lines)	13.333 ms (1250 lines)
	U V-Blanking	0.655 ms (45 lines)	0.525 ms (42 lines)	0.527 ms (48 lines)	0.533 ms (50 lines)
	Q V-Sync. width	0.044 ms (3 lines)	0.038 ms (3 lines)	0.033 ms (3 lines)	0.032 ms (3 lines)
	R V-Back porch	0.568 ms (39 lines)	0.475 ms (38 lines)	0.483 ms (44 lines)	0.491 ms (46 lines)
	S V-Active	12.667 ms (870 lines)	12.804 ms (1024 lines)	11.235 ms (1024 lines)	12.800 ms (1200 lines)
T V-Front porch	0.044 ms (3 lines)	0.013 ms (1 line)	0.011 ms (1 line)	0.011 ms (1 line)	
Sync polarity (H / V)		Negative / Negative	Positive / Positive	Positive / Positive	Positive / Positive

Note: All modes are Non-Interlaced.
 * Factory Presets have exact size & centering.
 ** Factory Reservation have approximate size & centering.
 *** Requires the use of Optional Mac Adapter UNIMAC-82D.

Trouble Shooting

For safety, please observe the following points.

- **When trouble occurs, turn the power OFF immediately and contact your dealer.**
If smoke comes out of this unit or a bad odor or strange noise comes out, continuing to use the unit can cause a fire or electrical shock. Turn the power OFF immediately, unplug the power cord from the outlet and contact your dealer.
- **Absolutely do not remove the rear cover.**
There are parts at high voltage inside, so touching them can cause an electrical shock. Leave inspection, adjustment and cleaning of the interior to your dealer.
- **Do not put anything inside the casing.**
If liquid or a foreign object should get inside accidentally, immediately turn the power OFF, unplug the power cord from the outlet and contact your dealer. Continuing to use the unit can cause a fire, electrical shock or breakdown of the unit.

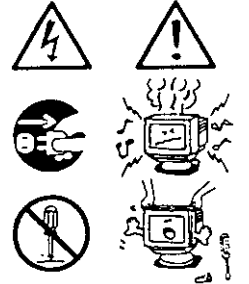

If trouble occurs with the display unit, perform the following checks and take the indicated action; if the trouble persists, please consult with your dealer.

Symptom	Check	Action
There is no display. 	power cord / plug — power switch signal cable The power saving function might have acted (if so the pilot LED will be yellow). Check that the active input is selected. See Page 13, Signal.	Plug the power cord into the outlet correctly. Press the power switch. Connect the signal cable correctly. Release the power saving function by operating the mouse or keyboard. For additional details please read the Operation Manual of the hardware you are using.
The image is too large or too small, or it is displaced from the correct position. 	The mode is not registered.	Perform the desired settings and then save them by waiting 20 seconds or pressing the [1] "Ext" key.
The display color is abnormal. (Example) The color is uneven or off-color. The image distortion and or tilt is large. 	Is there something that produces a magnetic field nearby? (Examples) Television monitor, another computer display unit, speaker, etc.; was the orientation of the monitor perhaps changed while it was in use?	Remove the source of the magnetic field. Perform degaussing. Make sure your cable is correct. Connect the signal connector correctly. Try a different orientation.
The background of the image is bright. The background of the image is colored. The character gets partially distorted. The image is dark. 	The computer in use is Macintosh. The signal output of the computer in use is improper.	Press the operating keys [1] and [2] together at the same time. You can then adjust this unit with the signal output of the computer. One more pressing or execution of recall can cancel this function. * This function is effective for a specified computer. If there is no problem in normal use, avoid the use of this function.
Characters cannot be seen clearly; the image is too dark. 	Is the image signal level correctly adjusted? Is the brightness or contrast adjustment turned all the way down?	Check the video signal level from the computer and adjust it in the correct direction. Adjust the brightness and contrast.
The screen size and position do not change.	Is the input synchronization signal within the operating range?	Check the video output mode from the computer, and select a mode within the display unit operating range. For details, please read the Operation Manual of the hardware you are using.
The front panel keys fail to operate.	Are 2 or more keys being operated at the same time?	Operate only one key at a time.

Technical Support (USA Only)

If you have read the Operating Instructions and tried the troubleshooting procedures and are still having difficulty, please contact the dealer from whom the unit was purchased. You may also call the end user Technical Support telephone number which is operational 9:00 am to 7:00pm EST.

To contact the Technical Support Group call:
1-800-726-2797 (9:00 am to 7:00pm EST)

To locate the Nearest Authorized Panasonic Service Center call:
1-800-726-2797 (9:00 am to 7:00pm EST)

To obtain Operating Instructions and Service Manuals call:
Phone : 1-800-833-9626
Fax : 1-800-237-9080
(6:00 AM to 4:30 PM Pacific Time)

To locate the Nearest Sales Dealer call:
1-800-742-8086 (9:00 am to 7:00pm EST)

To get the latest Windows® 95 / 98 Panasonic Monitor INF Files, please see our world wide web pages at:
<http://www.panasonic.com/alive>