

EMI TEST REPORT

Test Report No. : 30IE0145-HO-08

Applicant : **Panasonic Corporation Automotive Systems Company**
Type of Equipment : **SMART RFU**
Model No. : **YEP0FX1521**
Test standard : **FCC Part 15 Subpart B: 2010**
FCC ID : **ACJ932YEP0FX1521**
Test Result : **Complied**

1. This test report shall not be reproduced in full or partial, without the written approval of UL Japan, Inc.
2. The results in this report apply only to the sample tested.
3. This sample tested is in compliance with the above regulation.
4. The test results in this report are traceable to the national or international standards.
5. This test report must not be used by the customer product certification, approval, or endorsement by NVLAP, NIST, or any agency of the Federal Government.

Date of test:

December 10, 2010

**Representative test
engineer:**

Satofumi Matsuyama
Engineer of EMC Service

Approved by:

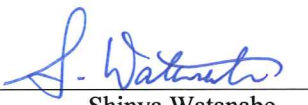
Shinya Watanabe
Leader of EMC Service



NVLAP LAB CODE: 200572-0

This laboratory is accredited by the NVLAP LAB CODE 200572-0, U.S.A. The tests reported herein have been performed in accordance with its terms of accreditation. *As for the range of Accreditation in NVLAP, you may refer to the WEB address, <http://www.ul.com/japan/jpn/pages/services/emc/about/mar1/index.jsp#nvlap>

UL Japan, Inc.

Head Office EMC Lab.

4383-326 Asama-cho, Ise-shi, Mie-ken 516-0021 JAPAN

Telephone : +81 596 24 8116

Facsimile : +81 596 24 8124

MF058b (15.09.10)

CONTENTS	PAGE
SECTION 1: Customer information	3
SECTION 2: Equipment under test (E.U.T.)	3
SECTION 3: Test specification, procedures & results	4
SECTION 4: Operation of E.U.T. during testing	6
SECTION 5: Radiated Emission	7
APPENDIX 1: Photographs of test setup.....	8
Radiated Emission	8
Worst Case Position (Horizontal: Z-axis/ Vertical:Y-axis).....	9
APPENDIX 2: Data of EMI test	10
Radiated Emission	10
APPENDIX 3: Test instruments	12

SECTION 1: Customer information

Company Name : Panasonic Corporation Automotive Systems Company
Address : 4261 Ikonobe-cho, Tsuzuki-ku, Yokohama city, Kanagawa-ken
224-8520, Japan
Telephone Number : +81-45-939-1665
Facsimile Number : +81-45-939-1917
Contact Person : Masahiro Yoshii

SECTION 2: Equipment under test (E.U.T.)

2.1 Identification of E.U.T.

Type of Equipment : SMART RFU
Model No. : YEP0FX1521
Serial No. : Refer to Clause 4.2
Rating : DC5.0V
Receipt Date of Sample : December 10, 2010
Country of Mass-production : Japan
Condition of EUT : Production prototype
(Not for Sale: This sample is equivalent to mass-produced items.)
Modification of EUT : No Modification by the test lab

2.2 Product Description

Model No: YEP0FX1521 (referred to as the EUT in this report) is the SMART RFU.

Radio Type : Receiver
Type of Receiver : Super Heterodyne
Frequency of Operation : 313.85MHz
Intermediate frequency : 10.7MHz
IF Filter bandwidth : 230kHz
Operating voltage (inner) : DC 5.0V
Antenna type : Inverted F Sheet-metal Antenna
Method of Frequency Generation : Crystal
Operating temperature range : -30 deg. C. to +80 deg. C.

FCC15.111(b)

The receiving antenna (of this EUT) is installed inside the EUT and cannot be removed (permanently attached). Therefore, Radiated emission test was performed.

UL Japan, Inc.

Head Office EMC Lab.

4383-326 Asama-cho, Ise-shi, Mie-ken 516-0021 JAPAN

Telephone : +81 596 24 8116

Facsimile : +81 596 24 8124

SECTION 3: Test specification, procedures & results

3.1 Test specification

Test Specification/Title : FCC Part 15 Subpart B: 2010, final revised on October 13, 2010

Title : FCC 47CFR Part15 Radio Frequency Device
Subpart B Unintentional Radiators

3.2 Procedures and results

Item	Test Procedure	Limits	Deviation	Worst margin	Result
Conducted emission	ANSI C63.4: 2003 7. AC powerline conducted emission measurements	Part 15 Subpart B 15.107(a)	N/A	N/A*1)	N/A
Radiated emission	ANSI C63.4: 2003 8. Radiated emission measurements	Part 15 Subpart B 15.109(a)	N/A	15.5dB 303.150MHz, QP Horizontal	Complied

*Note: UL Japan, Inc's EMI Work Procedure QPM05.

*1) The test is not applicable since the EUT is not the device that is designed to be connected to the public utility (AC) power line.

3.3 Addition to standard

No addition, exclusion nor deviation has been made from the standard.

3.4 Uncertainty

EMI

The following uncertainties have been calculated to provide a confidence level of 95% using a coverage factor k=2.

Test room (semi- anechoic chamber)	Radiated emission						
	(3m*)(±dB)				(1m*)(±dB)		(0.5m*)(±dB)
	9kHz -30MHz	30MHz -300MHz	300MHz -1GHz	1GHz -10GHz	10GHz -18GHz	18GHz -26.5GHz	26.5GHz -40GHz
No.1	2.9dB	4.8dB	5.0dB	3.9dB	4.3dB	4.5dB	4.3dB
No.2	3.5dB	4.8dB	5.1dB	4.0dB	4.2dB	4.4dB	4.2dB
No.3	3.8dB	4.6dB	4.7dB	4.0dB	4.2dB	4.5dB	4.2dB
No.4	3.5dB	4.4dB	4.9dB	4.0dB	4.2dB	4.6dB	4.2dB

*3m/1m/0.5m = Measurement distance

Radiated emission test(3m)

The data listed in this test report has enough margin, more than the site margin.

UL Japan, Inc.

Head Office EMC Lab.

4383-326 Asama-cho, Ise-shi, Mie-ken 516-0021 JAPAN

Telephone : +81 596 24 8116

Facsimile : +81 596 24 8124

3.5 Test Location

UL Japan, Inc. Head Office EMC Lab. *NVLAP Lab. code: 200572-0
4383-326 Asama-cho, Ise-shi, Mie-ken 516-0021 JAPAN
Telephone : +81 596 24 8116 Facsimile : +81 596 24 8124

	FCC Registration Number	IC Registration Number	Width x Depth x Height (m)	Size of reference ground plane (m) / horizontal conducting plane	Other rooms
No.1 semi-anechoic chamber	313583	2973C-1	19.2 x 11.2 x 7.7m	7.0 x 6.0m	No.1 Power source room
No.2 semi-anechoic chamber	655103	2973C-2	7.5 x 5.8 x 5.2m	4.0 x 4.0m	-
No.3 semi-anechoic chamber	148738	2973C-3	12.0 x 8.5 x 5.9m	6.8 x 5.75m	No.3 Preparation room
No.3 shielded room	-	-	4.0 x 6.0 x 2.7m	N/A	-
No.4 semi-anechoic chamber	134570	2973C-4	12.0 x 8.5 x 5.9m	6.8 x 5.75m	No.4 Preparation room
No.4 shielded room	-	-	4.0 x 6.0 x 2.7m	N/A	-
No.5 semi-anechoic chamber	-	-	6.0 x 6.0 x 3.9m	6.0 x 6.0m	-
No.6 shielded room	-	-	4.0 x 4.5 x 2.7m	4.75 x 5.4 m	-
No.6 measurement room	-	-	4.75 x 5.4 x 3.0m	4.75 x 4.15 m	-
No.7 shielded room	-	-	4.7 x 7.5 x 2.7m	4.7 x 7.5m	-
No.8 measurement room	-	-	3.1 x 5.0 x 2.7m	N/A	-
No.9 measurement room	-	-	8.0 x 4.5 x 2.8m	2.0 x 2.0m	-
No.10 measurement room	-	-	2.6 x 2.8 x 2.5m	2.4 x 2.4m	-
No.11 measurement room	-	-	3.1 x 3.4 x 3.0m	2.4 x 3.4m	-

* Size of vertical conducting plane (for Conducted Emission test) : 2.0 x 2.0m for No.1, No.2, No.3, and No.4 semi-anechoic chambers and No.3 and No.4 shielded rooms.

3.6 Test set up, Data of EMI, and Test instruments

Refer to APPENDIX.

SECTION 4: Operation of E.U.T. during testing

4.1 Operating modes

Mode	Remarks
Receiving mode	* SMART FOB (Transmitter) was operated manually by a test engineer and the test was performed with the EUT receiving 313.85MHz.

4.2 Configuration and peripherals

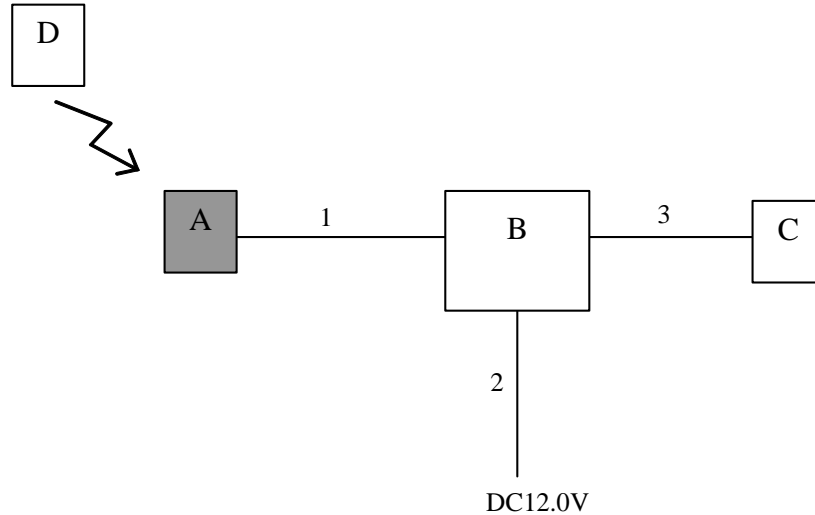

*Cabling and setup(s) were taken into consideration and test data was taken under worse case conditions.

Description of EUT and Support equipment

No.	Item	Model number	Serial number	Manufacturer	Remark
A	SMART RFU	YEP0FX1521	001	Panasonic Corporation Automotive Systems Company	EUT
B	SMART ECU	YEP0FX1519	001	Panasonic Corporation Automotive Systems Company	-
C	Jig	-	-	Panasonic Corporation Automotive Systems Company	-
D	SMART FOB	YEP0FX1560	001	Panasonic Corporation Automotive Systems Company	-

List of cables used

No.	Name	Length (m)	Shield		Remark
			Cable	Connector	
1	Signal Cable	5.1	Shielded	Shielded	-
2	DC Cable	1.5	Unshielded	Unshielded	-
3	Signal Cable	1.0	Unshielded	Unshielded	-

UL Japan, Inc.

Head Office EMC Lab.

4383-326 Asama-cho, Ise-shi, Mie-ken 516-0021 JAPAN

Telephone : +81 596 24 8116

Facsimile : +81 596 24 8124

SECTION 5: Radiated Emission

5.1 Operating environment

Test place : No.4 semi anechoic chamber
Temperature : See data
Humidity : See data

5.2 Test configuration

EUT was placed on a urethane platform of nominal size, 1.0m by 0.5m, raised 0.8m above the conducting ground plane. The EUT was set on the center of the tabletop.
Test was made with the antenna positioned in both the horizontal and vertical planes of polarization. The measurement antenna was varied in height above the conducting ground plane to obtain the maximum signal strength.
Photographs of the set up are shown in Appendix 1.

5.3 Test conditions

Frequency range : 30MHz-300MHz (Biconical antenna) / 300MHz-1000MHz (Logperiodic antenna)
1000MHz -2000MHz (Horn antenna)
Test distance : 3m
EUT position : Table top
EUT operation mode : See Clause 4.1

5.4 Test procedure

The height of the measuring antenna varied between 1 and 4m and EUT was rotated a full revolution in order to obtain the maximum value of the electric field intensity.
The measurements were performed for both vertical and horizontal antenna polarization with the Test Receiver, or the Spectrum Analyzer.
The radiated emission measurements were made with the following detector function of the test receiver and the Spectrum analyzer.

Frequency	Below 1GHz	Above 1GHz
Instrument used	Test Receiver	Spectrum Analyzer
IF Bandwidth	QP: BW 120kHz	PK: RBW:1MHz/VBW: 3MHz AV *1): RBW:1MHz/VBW:10Hz

*1) When using Spectrum analyzer, the test was made with adjusting span to zero by using peak hold.

- The noise levels were confirmed at each position of X, Y and Z axes of EUT to see the position of maximum noise, and the test was made at the position that has the maximum noise.

5.5 Test result

Summary of the test results: Pass

Date: December 10, 2010

Test engineer: Satofumi Matsuyama

UL Japan, Inc.

Head Office EMC Lab.

4383-326 Asama-cho, Ise-shi, Mie-ken 516-0021 JAPAN

Telephone : +81 596 24 8116

Facsimile : +81 596 24 8124