



# RADIO TEST REPORT

**Test Report No. : 10005913S-A**

**Applicant** : **Panasonic Corporation**  
**Automotive & Industrial Systems Company**

**Type of Equipment** : **Bluetooth Module Assy**

**Model No.** : **YEAP01A727**

**FCC ID** : **ACJ932YEAP01A727**

**Test regulation** : **FCC Part15 Subpart C: 2012**

**Test result** : **Complied**

1. This test report shall not be reproduced in full or partial, without the written approval of UL Japan, Inc.
2. The results in this report apply only to the sample tested.
3. This sample tested is in compliance with the limits of the above regulation.
4. The test results in this test report are traceable to the national or international standards.
5. This test report must not be used by the customer to claim product certification, approval, or endorsement by any agency of the Federal Government.
6. The opinions and the interpretations to the result of the description in this report are outside scopes where UL Japan has been accredited.

**Date of test:** February 26 to March 1, 2013

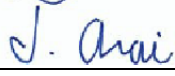
**Tested by:**   
Tatsuya Arai  
Engineer of WiSE Japan,  
UL Verification Service

**Approved by :**   
Go Ishiwata  
Manager of WiSE Japan,  
UL Verification Service

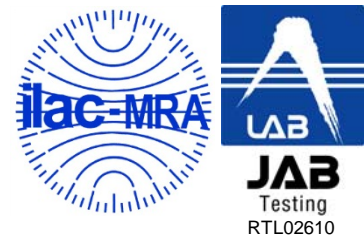

- The testing in which "Non-accreditation" is displayed is outside the accreditation scopes in UL Japan.
- There is no testing item of "Non-accreditation".

**UL Japan, Inc.**

**Shonan EMC Lab.**

1-22-3 Megumigaoka, Hiratsuka-shi, Kanagawa-ken, 259-1220 JAPAN

Telephone : +81 463 50 6400

Facsimile : +81 463 50 6401

13-EM-F0429



**Contents**

	<b><u>Page</u></b>
<b>SECTION 1: Customer information .....</b>	<b>4</b>
<b>SECTION 2: Equipment under test (E.U.T.) .....</b>	<b>4</b>
<b>SECTION 3: Test specification, procedures &amp; results .....</b>	<b>5</b>
<b>SECTION 4: Operation of E.U.T. during testing.....</b>	<b>8</b>
<b>SECTION 5: Carrier frequency separation .....</b>	<b>10</b>
<b>SECTION 6: 20dB bandwidth &amp; Occupied bandwidth (99%).....</b>	<b>10</b>
<b>SECTION 7: Number of hopping frequency .....</b>	<b>10</b>
<b>SECTION 8: Dwell time .....</b>	<b>10</b>
<b>SECTION 9: Maximum peak output power.....</b>	<b>10</b>
<b>SECTION 10: Radiated emission .....</b>	<b>11</b>
<b>SECTION 11: Spurious emissions (Antenna port conducted).....</b>	<b>12</b>
<b>Contents of APPENDIXES.....</b>	<b>13</b>
<b>APPENDIX 1: Data of radio tests.....</b>	<b>14</b>
<b>APPENDIX 2: Test instruments .....</b>	<b>60</b>
<b>APPENDIX 3: Photographs of test setup.....</b>	<b>61</b>

---

**UL Japan, Inc.**

**Shonan EMC Lab.**

1-22-3 Megumigaoka, Hiratsuka-shi, Kanagawa-ken, 259-1220 JAPAN

Telephone : +81 463 50 6400

Facsimile : +81 463 50 6401

## **SECTION 1: Customer information**

Company Name : Panasonic Corporation Automotive & Industrial Systems Company  
Brand Name : Panasonic  
Address : 4261 Ikonobe-cho, Tsuzuki-ku, Yokohama-shi, Kanagawa 224-8520 Japan  
Telephone Number : +81-50-3689-6973  
Facsimile Number : +81-45-931-0806  
Contact Person : Ichiro Furuya

## **SECTION 2: Equipment under test (E.U.T.)**

### **2.1 Identification of E.U.T.**

Type of Equipment : Bluetooth Module Assy  
Model No. : YEAP01A727  
Serial No. : Refer to 4.2 in this report.  
Rating : DC5.0V  
Receipt Date of Sample : February 26, 2013  
Country of Mass-production : Japan  
Condition of EUT : Engineering prototype  
(Not for Sale: This sample is equivalent to mass-produced items.)  
Modification of EUT : No modification by the test lab.

### **2.2 Product description**

Model: YEAP01A727 (referred to as the EUT in this report) is a Bluetooth Module Assy.  
Similar model: YEAP01B898 (The difference is the circuit of LCD block.)

Clock frequency(ies) in the system : 26MHz, 32.768kHz

### **Radio specification**

Equipment type : Transceiver  
Frequency of operation : 2402-2480MHz  
Bandwidth / Channel spacing : 79MHz & 1MHz  
Type of modulation : FHSS (GFSK,  $\pi/4$ -DQPSK, 8DPSK)  
Antenna type : Monopole \*1), Dipole  
Antenna connector type : U.FL  
Antenna gain with cable loss : -3.8dBi (N1KYYYYY00019), -4.4dBi (N1KYYYYY00030),  
-2.9dBi (BT-MAIN-001)  
ITU code : F1D, G1D  
Operation temperature range : -30 to +85 deg. C.

\*1) N1KYYYYY00019 or N1KYYYYY00030 is installed to the module. The length of coaxial cable is different.

Antenna	Cable Loss (dB)
N1KYYYYY00019	0.165
N1KYYYYY00030	0.743

FCC 15.31 (e)

The Bluetooth module is provided with stable power supply DC 3.3V and DC1.8V from the host device, therefore, the equipment complies with the power supply regulation.

FCC 15.203

The EUT complies with the requirement, because the antenna has a unique coupling (U.FL).

---

**UL Japan, Inc.**

**Shonan EMC Lab.**

1-22-3 Megumigaoka, Hiratsuka-shi, Kanagawa-ken, 259-1220 JAPAN

Telephone : +81 463 50 6400

Facsimile : +81 463 50 6401

## **SECTION 3: Test specification, procedures & results**

### **3.1 Test specification**

Test specification : FCC Part 15 Subpart C: 2012, final revised on December 12, 2012 and effective January 21, 2013  
Title : FCC 47CFR Part15 Radio Frequency Device Subpart C Intentional Radiators  
Section 15.207 Conducted limits  
Section 15.209 Radiated emission limits, general requirements  
Section 15.247 Operation within the bands 902-928MHz, 2400-2483.5MHz,  
and 5725-5850MHz

### **3.2 Procedures & Results**

Item	Test Procedure	Specification	Remarks	Deviation	Worst Margin	Results
Conducted emission	ANSI C63.4:2009 7. AC powerline conducted emission measurements	FCC 15.207	-	N/A *1)	N/A	N/A
Carrier frequency separation	FCC Public Notice DA 00-705 & ANSI C63.4:2009 13. Measurement of intentional radiators	FCC 15.247 (a)(1)	Conducted	N/A	*See data.	Complied
20dB bandwidth	FCC Public Notice DA 00-705 & ANSI C63.4:2009 13. Measurement of intentional radiators	FCC 15.247 (a)(1)	Conducted	N/A		-
Number of hopping frequency	FCC Public Notice DA 00-705 & ANSI C63.4:2009 13. Measurement of intentional radiators	FCC 15.247 (a)(1)(iii)	Conducted	N/A		Complied
Dwell time	FCC Public Notice DA 00-705 & ANSI C63.4:2009 13. Measurement of intentional radiators	FCC 15.247 (a)(1)(iii)	Conducted	N/A		Complied
Maximum peak output power	FCC Public Notice DA 00-705 & ANSI C63.4:2009 13. Measurement of intentional radiators	FCC 15.247 (b)(1)	Conducted	N/A		Complied
Band edge compliance & Spurious emission	FCC Public Notice DA 00-705 & ANSI C63.4:2009 13. Measurement of intentional radiators	FCC 15.247 (d) 15.209	Conducted/ Radiated	N/A		10.4dB Freq.: 2520.000MHz Polarization: Vertical Detection: Average Mode: Tx 2480MHz, 3-DH5 Antenna:N1KYYYY00019
Note: UL Japan's Work Procedures No. 13-EM-W0420 and 13-EM-W0422 *1) The test is not applicable since the EUT does not have AC Mains.						

**UL Japan, Inc.**

**Shonan EMC Lab.**

1-22-3 Megumigaoka, Hiratsuka-shi, Kanagawa-ken, 259-1220 JAPAN

Telephone : +81 463 50 6400

Facsimile : +81 463 50 6401

### 3.3 Addition to standard

Item	Test Procedure	Specification	Remarks	Worst Margin	Results
Occupied Bandwidth (99%)	ANSI C63.4:2009 13. Measurement of intentional radiators, RSS-Gen 4.6.1	-	Conducted	-	-

Note: UL Japan's Work Procedures No. 13-EM-W0420 and 13-EM-W0422

\* Other than above, no addition, exclusion nor deviation has been made from the standard.

### 3.4 Uncertainty

The following uncertainties have been calculated to provide a confidence level of 95% using a coverage factor k=2.

Item	Frequency range	No.1 SAC <sup>*1</sup> /SR <sup>*2</sup> (±)	No.2 SAC/SR (±)	No.3 SAC/SR (±)
<b>Radiated emission (Measurement distance: 3m)</b>	9kHz-30MHz	3.7 dB	3.7 dB	3.6 dB
	30MHz-300MHz	4.9 dB	5.1 dB	4.9 dB
	300MHz-1GHz	5.0 dB	5.2 dB	4.9 dB
	1GHz-15GHz	4.8 dB	4.8 dB	4.9 dB
<b>Radiated emission (Measurement distance: 1m)</b>	15GHz-18GHz	5.6 dB	5.6 dB	5.6 dB
	18GHz-40GHz	4.6 dB	4.3 dB	4.4 dB

\*1: SAC=Semi-Anechoic Chamber

\*2: SR= Shielded Room is applied besides radiated emission

The data listed in this test report has enough margin, more than site margin.

#### Antenna port conducted test

Power measurement uncertainty above 1GHz for this test was: (±) 1.5dB

Spurious emission (Conducted) measurement (below 1GHz) uncertainty for this test was: (±) 1.7dB

Spurious emission (Conducted) measurement (1G-3GHz) uncertainty for this test was: (±) 2.3dB

Spurious emission (Conducted) measurement (3G-18GHz) uncertainty for this test was: (±) 3.0dB

Spurious emission (Conducted) measurement (18G-26.5GHz) uncertainty for this test was: (±) 2.9dB

Bandwidth measurement uncertainty for this test was: (±) 5.4%

## UL Japan, Inc.

### Shonan EMC Lab.

1-22-3 Megumigaoka, Hiratsuka-shi, Kanagawa-ken, 259-1220 JAPAN

Telephone : +81 463 50 6400

Facsimile : +81 463 50 6401

### 3.5 Test location

UL Japan, Inc. Shonan EMC Lab.

1-22-3, Megumigaoka, Hiratsuka-shi, Kanagawa-ken 259-1220 JAPAN

Telephone number : +81 463 50 6400

Facsimile number : +81 463 50 6401

JAB Accreditation No. : RTL02610

	FCC Registration No.	IC Registration No.	Width x Depth x Height (m)	Size of reference ground plane (m) / horizontal conducting plane	Maximum measurement distance
<input type="checkbox"/> No.1 Semi-anechoic chamber	697847	2973D-1	20.6 x 11.3 x 7.65	20.6 x 11.3	10m
<input type="checkbox"/> No.2 Semi-anechoic chamber	697847	2973D-2	20.6 x 11.3 x 7.65	20.6 x 11.3	10m
<input checked="" type="checkbox"/> No.3 Semi-anechoic chamber	697847	2973D-3	12.7 x 7.7 x 5.35	12.7 x 7.7	5m
<input type="checkbox"/> No.4 Semi-anechoic chamber	-	-	8.1 x 5.1 x 3.55	8.1 x 5.1	-
<input type="checkbox"/> No.1 shielded room	-	-	6.8 x 4.1 x 2.7	6.8 x 4.1	-
<input type="checkbox"/> No.2 shielded room	-	-	6.8 x 4.1 x 2.7	6.8 x 4.1	-
<input checked="" type="checkbox"/> No.3 shielded room	-	-	6.3 x 4.7 x 2.7	6.3 x 4.7	-
<input type="checkbox"/> No.4 shielded room	-	-	4.4 x 4.7 x 2.7	4.4 x 4.7	-
<input checked="" type="checkbox"/> No.5 shielded room	-	-	7.8 x 6.4 x 2.7	7.8 x 6.4	-
<input type="checkbox"/> No.6 shielded room	-	-	7.8 x 6.4 x 2.7	7.8 x 6.4	-

### 3.6 Test setup, Data of test & Test instruments

Refer to APPENDIX 1 to 3.

**UL Japan, Inc.**

**Shonan EMC Lab.**

1-22-3 Megumigaoka, Hiratsuka-shi, Kanagawa-ken, 259-1220 JAPAN

Telephone : +81 463 50 6400

Facsimile : +81 463 50 6401

## **SECTION 4: Operation of E.U.T. during testing**

### **4.1 Operating mode**

<b>Test item</b>	<b>Operating mode</b>	<b>Tested frequency</b>
Carrier frequency separation	Transmitting Hopping ON (DH5/3DH5)/Inquiry, Payload: PRBS9	-
20dB bandwidth	Transmitting Hopping OFF (DH5/3DH5)/Inquiry, Payload: PRBS9	2402MHz, 2441MHz, 2480MHz
Number of hopping frequency	Transmitting Hopping ON (DH5/3DH5)/Inquiry, Payload: PRBS9	-
Dwell time	Transmitting (Hopping ON), Payload: PRBS9 -DH1, -DH3, -DH5 -3DH1, -3DH3, -3DH5 -Inquiry	-
Maximum peak output power	Transmitting (Hopping OFF), Payload: PRBS9 -DH5, -2DH5, -3DH5	2402MHz, 2441MHz, 2480MHz
Band edge compliance & Spurious emission (Conducted)	Transmitting (DH5/3DH5), Payload: PRBS9 -Hopping ON -Hopping OFF	Band edge compliance: 2402MHz, 2480MHz
(Radiated)	Transmitting (DH5/3DH5), Payload: PRBS9	Spurious emission: 2402MHz, 2441MHz, 2480MHz
99% occupied bandwidth	Transmitting (DH5/3DH5), Payload: PRBS9 -Hopping ON -Hopping OFF	2402MHz, 2441MHz, 2480MHz

\*As a result of preliminary test, the formal test was performed with the above modes, which had the maximum payload (except Dwell time test).

\*Remarks: Test was not performed at AFH mode, because the decrease of number of channel (min: 20ch) at AFH mode does not affect the output power and bandwidth of the EUT.

As this device had AFH mode and frequency separation could not meet the requirement of over 20dB BW without 2/3 relaxation, 125mW power limit was applied to it.

EUT has the power settings by the software as follows;

Power settings	Fixed (The setting is not controlled by the software and it is equivalent to that of mass- produced items.)
Software	HCI Tester Ver 3.0.0.12

#### **Antenna and bottom plate:**

<b>Test item</b>	<b>Antenna</b>
Radiated emission	N1KYYYY00019 *1) BT-MAIN-001
Other items	-

\*1) The carrier level and noise levels were confirmed with two monopole antennas to see the case of maximum noise, and the test was made at the case that has the maximum noise.

**Justification:** The system was configured in typical fashion (as customer would normally use it) for testing.

**UL Japan, Inc.**

**Shonan EMC Lab.**

1-22-3 Megumigaoka, Hiratsuka-shi, Kanagawa-ken, 259-1220 JAPAN

Telephone : +81 463 50 6400

Facsimile : +81 463 50 6401

## 4.2 Configuration and peripherals

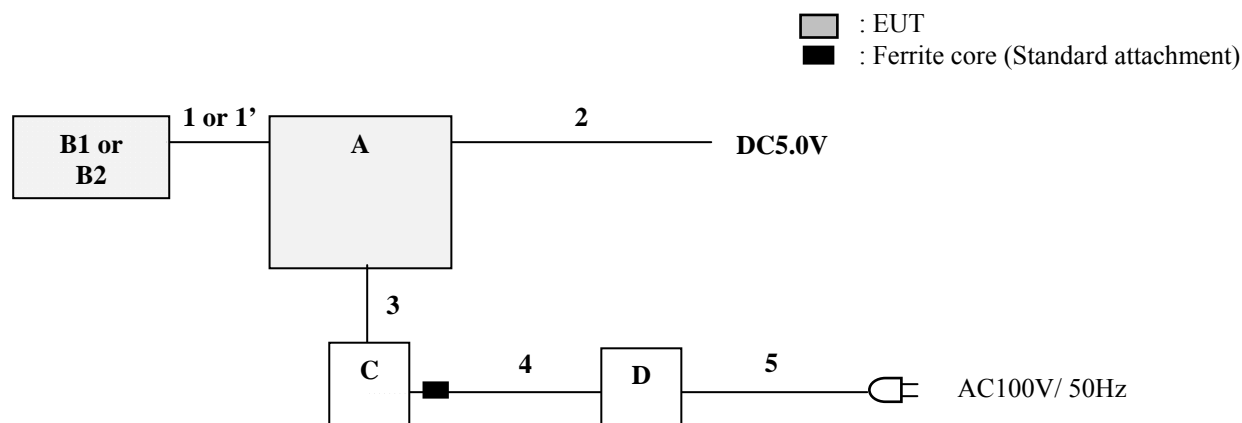

\* Test data was taken under worse case conditions.

### Description of EUT and support equipment

No.	Item	Model number	Serial number	Manufacturer	Remarks
A	Bluetooth Module Assy	YEAP01A727	11	Panasonic Corporation	EUT
B1	Monopole Antenna	NIKYYYY00019	-	NISSEI ELECTRIC CO., LTD.	EUT
B2	Dipole Antenna	BT-MAIN-001	-	Panasonic Corporation	EUT
C	Test Jig	PCA-A-036702	48579	Panasonic Corporation	-
D	AC Adaptor	A15D3-05MP	A102901991	TEXAS INSTRUMENTS JAPAN	-

### List of cables used

No.	Cable name	Length (m)	Shield		Remark
			Cable	Connector	
1	Antenna	0.04	Shielded	Shielded	for Monopole Antenna
1'	Antenna	0.05	Shielded	Shielded	for Dipole Antenna
2	DC	2.3	Unshielded	Unshielded	-
3	Signal	0.6	Unshielded	Unshielded	-
4	DC	1.5	Unshielded	Unshielded	-
5	AC	1.8	Unshielded	Unshielded	-

**UL Japan, Inc.**

**Shonan EMC Lab.**

1-22-3 Megumigaoka, Hiratsuka-shi, Kanagawa-ken, 259-1220 JAPAN

Telephone : +81 463 50 6400

Facsimile : +81 463 50 6401

## **SECTION 5: Carrier frequency separation**

### **Test procedure**

The carrier frequency separation was measured with a spectrum analyzer connected to the antenna port.

Summary of the test results: Pass  
Refer to APPENDIX 1

## **SECTION 6: 20dB bandwidth & Occupied bandwidth (99%)**

### **Test procedure**

The bandwidth was measured with a spectrum analyzer connected to the antenna port.

Summary of the test results: Pass  
Refer to APPENDIX 1

## **SECTION 7: Number of hopping frequency**

### **Test procedure**

The number of hopping frequency was measured with a spectrum analyzer connected to the antenna port.

Summary of the test results: Pass  
Refer to APPENDIX 1

## **SECTION 8: Dwell time**

### **Test procedure**

The dwell time was measured with a spectrum analyzer connected to the antenna port.

Summary of the test results: Pass  
Refer to APPENDIX 1

## **SECTION 9: Maximum peak output power**

### **Test procedure**

The maximum peak output power was measured with a power meter connected to the antenna port.

Summary of the test results: Pass  
Refer to APPENDIX 1

---

## **UL Japan, Inc.**

### **Shonan EMC Lab.**

1-22-3 Megumigaoka, Hiratsuka-shi, Kanagawa-ken, 259-1220 JAPAN

Telephone : +81 463 50 6400

Facsimile : +81 463 50 6401

## **SECTION 10: Radiated emission**

### **10.1 Operating environment**

Test place : See test data (APPENDIX 1)  
Temperature : See test data (APPENDIX 1)  
Humidity : See test data (APPENDIX 1)

### **10.2 Test configuration**

EUT was placed on a urethane platform of nominal size, 0.5m by 0.5m, raised 0.8m above the conducting ground plane. Photographs of the set up are shown in APPENDIX 3.

### **10.3 Test conditions**

Frequency range : 30MHz to 25GHz  
EUT position : Table top

### **10.4 Test procedure**

The Radiated Electric Field Strength intensity has been measured on a semi-anechoic chamber with a ground plane and at a distance of 3m (below 15GHz) / 1m (above 15GHz) (Refer to Figure 1). Measurements were performed with quasi-peak, peak and average detector. The measuring antenna height was varied between 1 and 4m and EUT was rotated a full revolution in order to obtain the maximum value of the electric field intensity. The measurements were performed for both vertical and horizontal antenna polarization.

The radiated emission measurements were made with the following detection of the test receiver.

Frequency	30-1000MHz	1-25GHz		20dBc
Detection type	Quasi-Peak	Peak	* Average	Peak
IF Bandwidth	120kHz	RBW: 1MHz VBW: 3MHz	RBW: 1MHz VBW: 10Hz	RBW: 100kHz VBW: 300kHz

\* When using Spectrum analyzer, the test was made with adjusting span to zero by using peak hold. Although 00-705 accepts VBW=10Hz for AV measurements, confirmed that superfluous smoothing was not performed.

The carrier level and noise levels were confirmed at each position of X, Y and Z axes of EUT to see the position of maximum noise, and the test was made at the position that has the maximum noise.

Worst position:

Frequency range		Below 1GHz	Above 1GHz	Carrier
EUT (Module & Monopole Antenna)	Horizontal	Z	Z	X
	Vertical	Z	Z	Z

Frequency range		Below 1GHz	Above 1GHz	Carrier
EUT (Module & Dipole Antenna)	Horizontal	Y	Y	X
	Vertical	Z	Y	Z

\* The definition of the axis was listed in a 'Pre-check of the worst position' in APPENDIX 3.

**UL Japan, Inc.**

**Shonan EMC Lab.**

1-22-3 Megumigaoka, Hiratsuka-shi, Kanagawa-ken, 259-1220 JAPAN

Telephone : +81 463 50 6400

Facsimile : +81 463 50 6401

**Figure 1. Antenna angle**

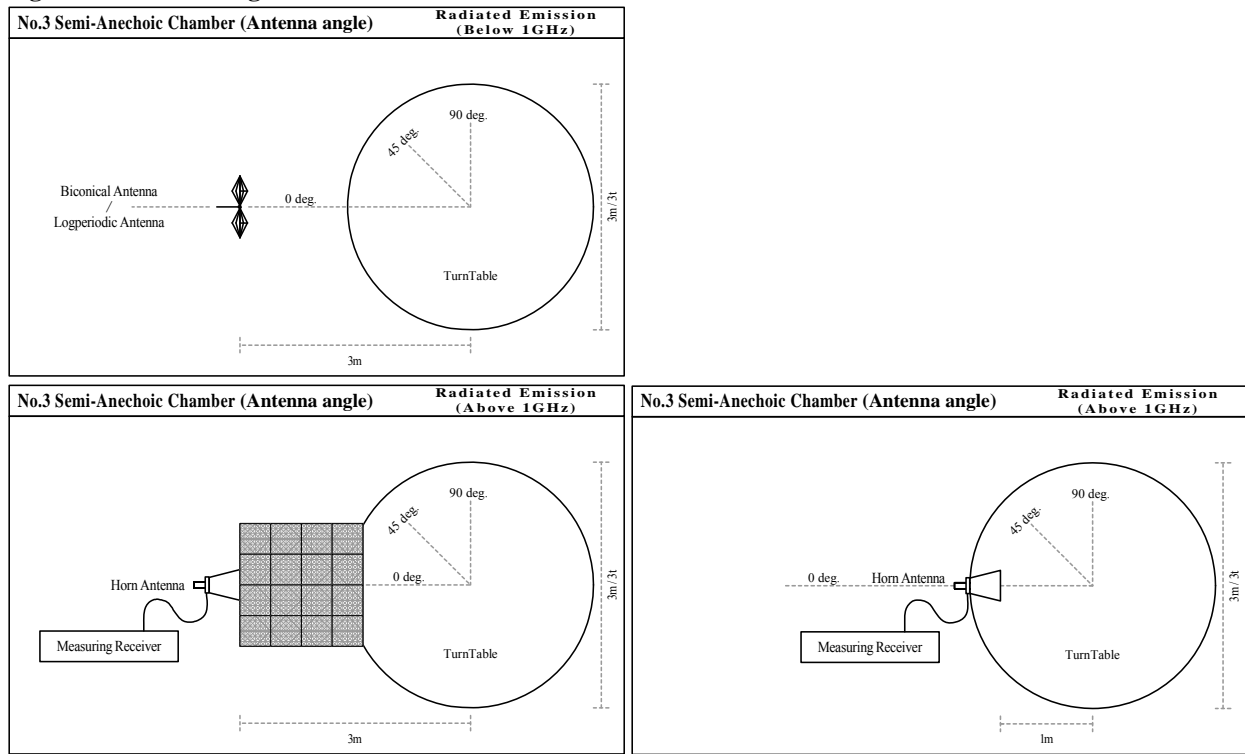

**10.5 Band edge**

Band edge level at 2390MHz and 2483.5MHz is below the limits of FCC 15.209 and band edge level at 2400MHz is below the 20dBc. Refer to the data.

**10.6 Results**

Summary of the test results : Pass \*No noise was detected above the 5<sup>th</sup> order harmonics.  
Refer to APPENDIX 1

**SECTION 11: Spurious emissions (Antenna port conducted)**

**Test procedure**

The Out of Band Emissions was measured with a spectrum analyzer connected to the antenna port.  
In any 100kHz bandwidth outside the frequency band in which the spread spectrum intentional radiator is operating, the radio frequency power that is produced by the intentional radiator confirmed 20dB below that in the 100kHz bandwidth within the band that contains the highest level of the desired power, based on a radiated measurement.  
In the frequency range below 30MHz, RBW was narrowed to separate the noise contents.  
Then, wide-band noise near the limit was checked separately, however the noise was not detected as shown in the chart. (9kHz-150kHz:RBW=200Hz, 150kHz-30MHz:RBW=10kHz)

Summary of the test results: Pass  
Refer to APPENDIX 1

## **Contents of APPENDIXES**

### **APPENDIX 1: Data of Radio tests**

20dB bandwidth and Carrier frequency separation  
Number of hopping frequency  
Dwell time  
Maximum peak output power  
Radiated emission  
Spurious emission (Antenna port conducted)  
Occupied bandwidth

### **APPENDIX 2: Test instruments**

Test instruments

### **APPENDIX 3: Photographs of test setup**

Radiated emission  
Pre-check of worst position  
Antenna type

---

**UL Japan, Inc.**

**Shonan EMC Lab.**

1-22-3 Megumigaoka, Hiratsuka-shi, Kanagawa-ken, 259-1220 JAPAN

Telephone : +81 463 50 6400

Facsimile : +81 463 50 6401

## APPENDIX 1: Data of Radio tests

### 20dB Bandwidth and Carrier Frequency Separation

Test place                      UL Japan, Inc. Shonan EMC Lab.                      No.3 Shielded Room  
 Date                              March 1, 2013  
 Temperature / Humidity        22 deg.C                      , 31 %RH  
 Engineer                        Tatsuya Arai  
 Mode                              Tx, Bluetooth, BDR, PRBS9

Mode	Freq. [MHz]	20dB Bandwidth [MHz]	Carrier Frequency Separation [MHz]	Limit for Carrier Frequency Separation [MHz]
DH5	2402.0	0.956	1.000	>= 0.637
DH5	2441.0	0.947	1.000	>= 0.631
DH5	2480.0	0.951	1.000	>= 0.634
Inquiry	2441.0	0.824	2.000	>= 0.549

Limit: Two-thirds of 20dB Bandwidth or 25kHz (whichever is greater).

No limit applies to 20dB Bandwidth.

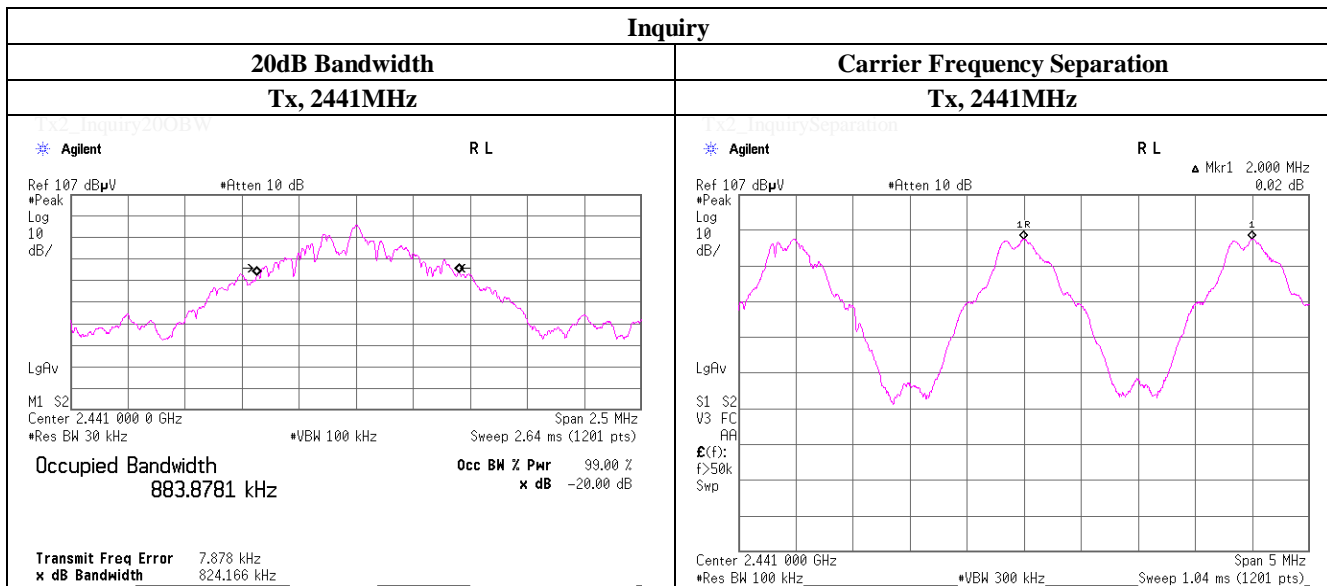

**UL Japan, Inc.**

**Shonan EMC Lab.**

1-22-3 Megumigaoka, Hiratsuka-shi, Kanagawa 259-1220 JAPAN

Telephone : +81 463 50 6400

Facsimile : +81 463 50 6401

## 20dB Bandwidth and Carrier Frequency Separation

Tx, Bluetooth, BDR, PRBS9

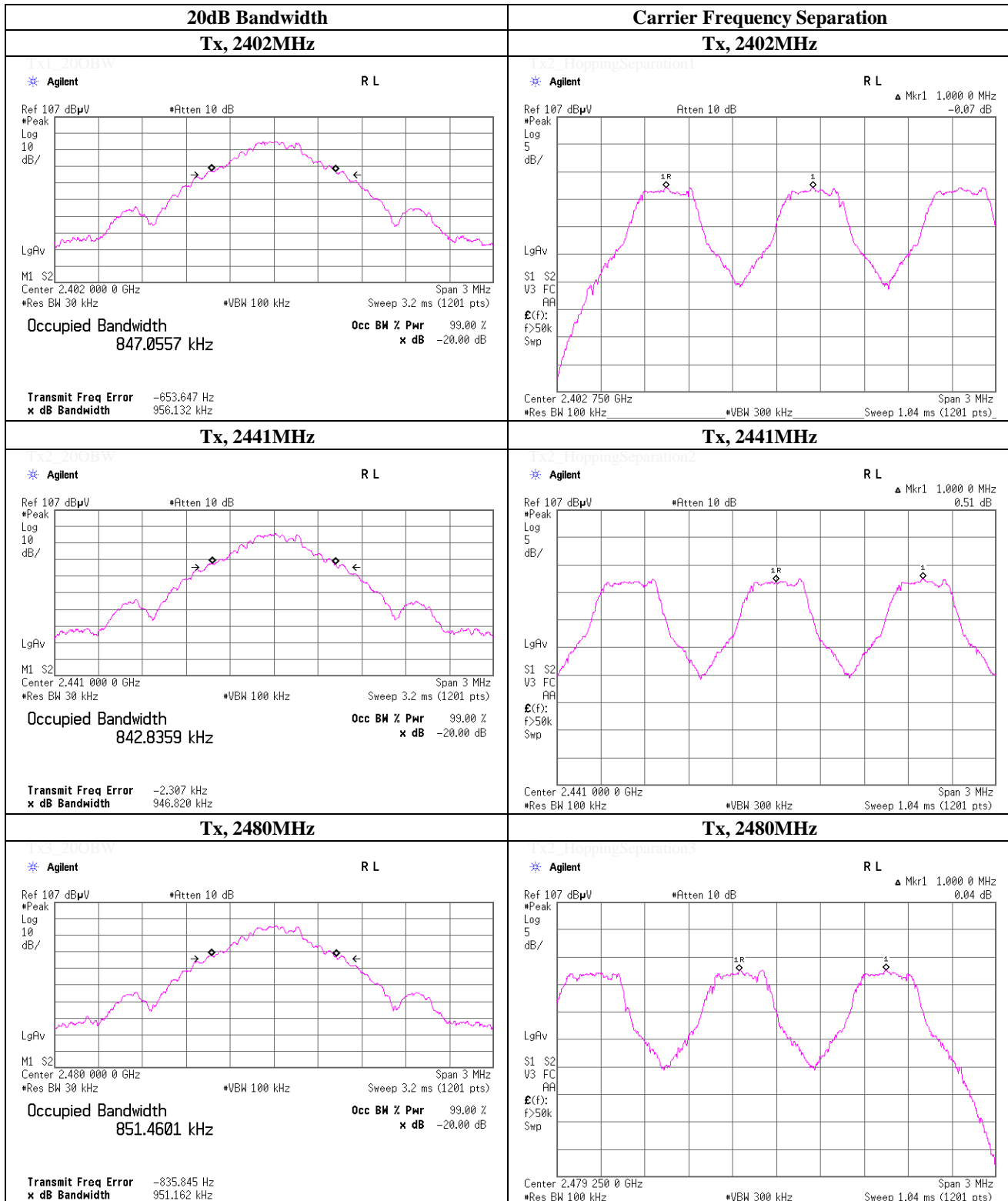

**UL Japan, Inc.**

**Shonan EMC Lab.**

1-22-3 Megumigaoka, Hiratsuka-shi, Kanagawa 259-1220 JAPAN

Telephone : +81 463 50 6400

Facsimile : +81 463 50 6401

## 20dB Bandwidth and Carrier Frequency Separation

Test place                   UL Japan, Inc. Shonan EMC Lab.           No.5 Shielded Room  
 Date                            March 1, 2013  
 Temperature / Humidity    22 deg.C       , 31 %RH  
 Engineer                    Tatsuya Arai  
 Mode                         Tx, Bluetooth, EDR, PRBS9

Mode	Freq. [MHz]	20dB Bandwidth [MHz]	Carrier Frequency Separation [MHz]	Limit for Carrier Frequency Separation [MHz]
3-DH5	2402.0	1.318	1.000	>= 0.879
3-DH5	2441.0	1.331	1.000	>= 0.888
3-DH5	2480.0	1.317	1.000	>= 0.878

Limit: Two-thirds of 20dB Bandwidth or 25kHz (whichever is greater).

No limit applies to 20dB Bandwidth.

**UL Japan, Inc.**

**Shonan EMC Lab.**

1-22-3 Megumigaoka, Hiratsuka-shi, Kanagawa 259-1220 JAPAN

Telephone : +81 463 50 6400

Facsimile : +81 463 50 6401

## 20dB Bandwidth and Carrier Frequency Separation

### Tx, Bluetooth, EDR, PRBS9

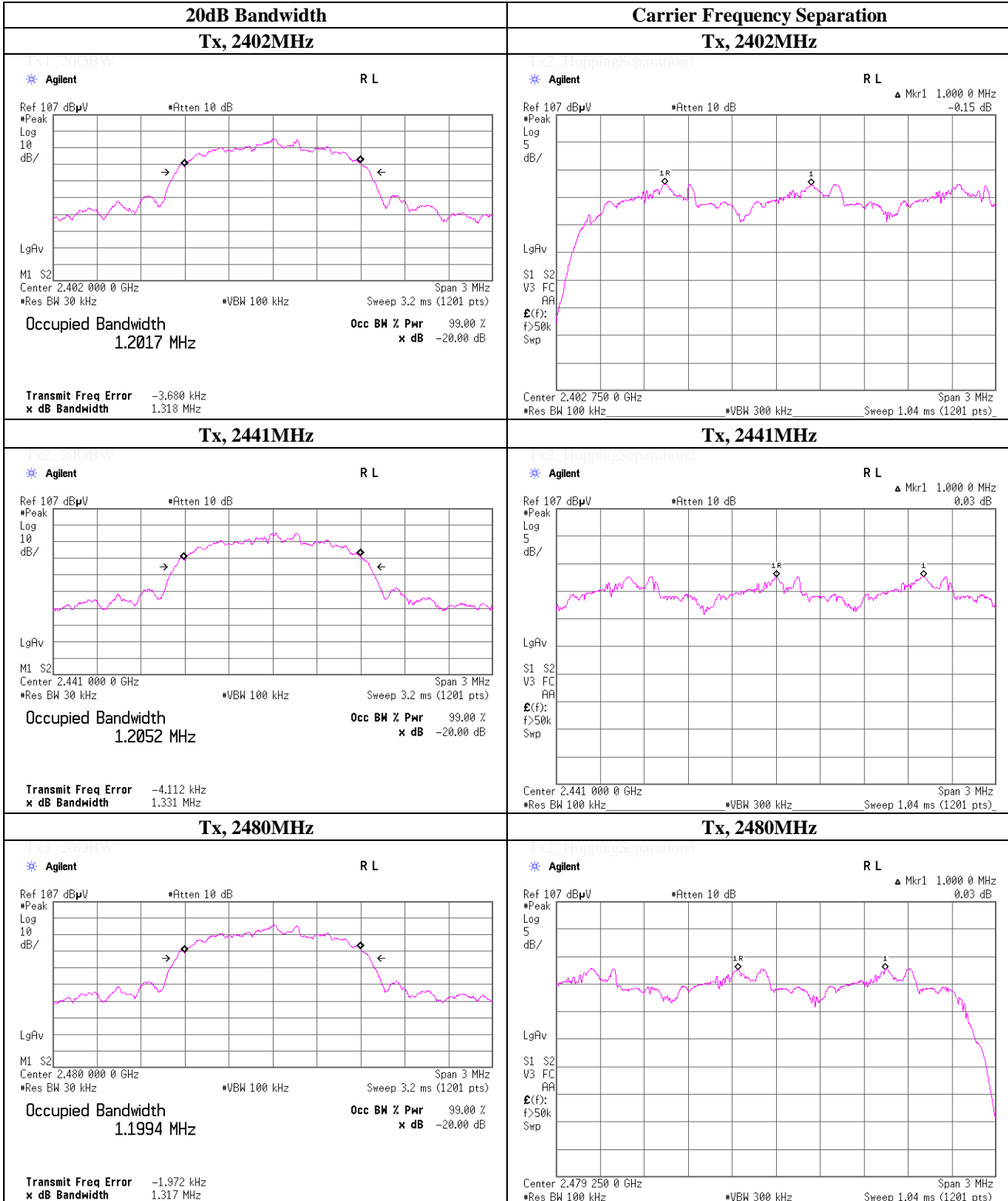

**UL Japan, Inc.**

**Shonan EMC Lab.**

1-22-3 Megumigaoka, Hiratsuka-shi, Kanagawa 259-1220 JAPAN

Telephone : +81 463 50 6400

Facsimile : +81 463 50 6401

### Number of Hopping Frequency

Test place	UL Japan, Inc. Shonan EMC Lab.	No.3 Shielded Room
Date	March 1, 2013	
Temperature / Humidity	22 deg.C , 31 %RH	
Engineer	Tatsuya Arai	
Mode	Tx, Bluetooth, BDR, PRBS9	

Mode	Number of Channel [times]	Limit [times]
DH5	79	>= 15

\* Test was not performed at AFH mode whose number of hopping channel is 20 channels because this Bluetooth radio is in compliance of Bluetooth Specification.

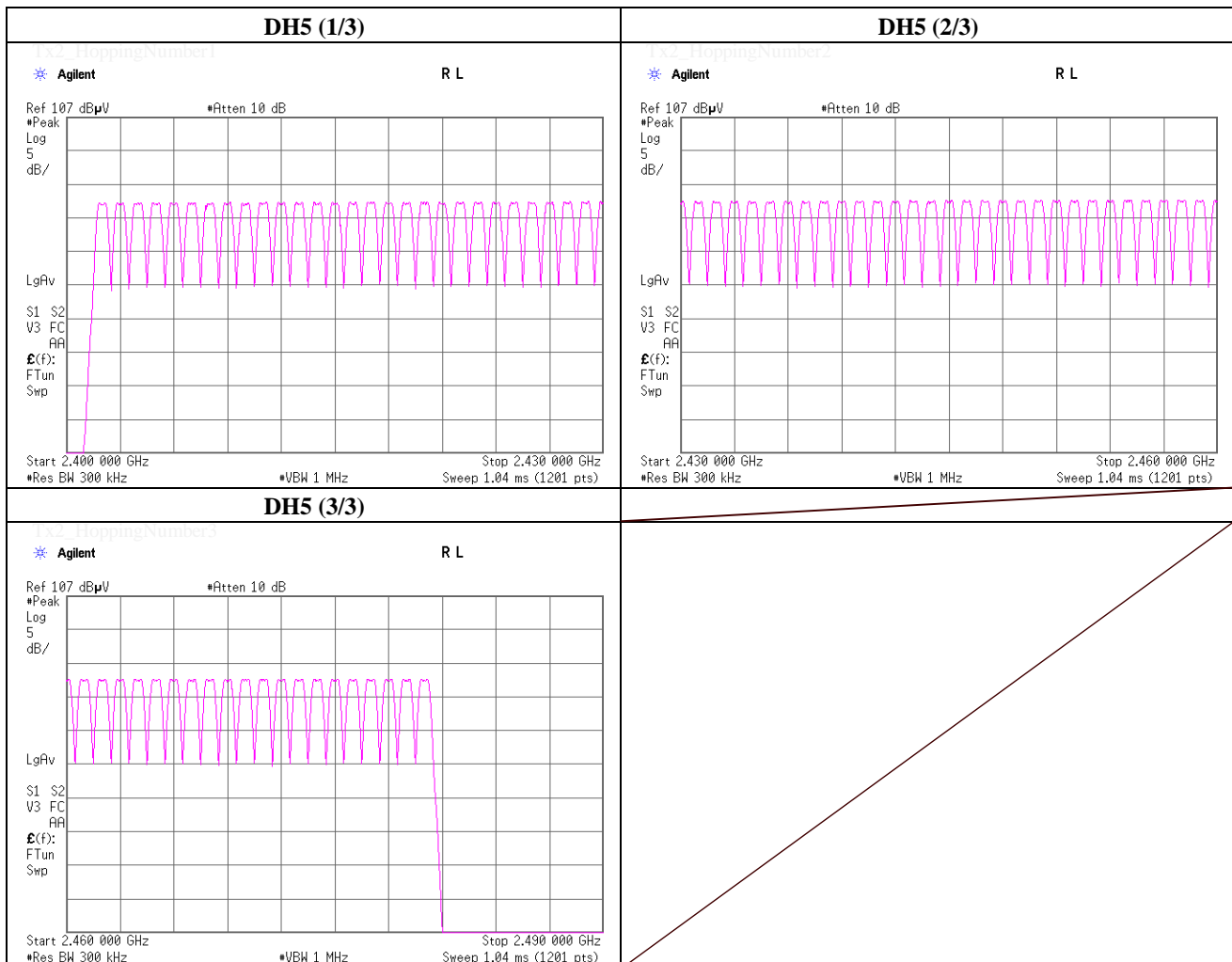

**UL Japan, Inc.**  
**Shonan EMC Lab.**  
 1-22-3 Megumigaoka, Hiratsuka-shi, Kanagawa 259-1220 JAPAN  
 Telephone : +81 463 50 6400  
 Facsimile : +81 463 50 6401

### Number of Hopping Frequency

Test place	UL Japan, Inc. Shonan EMC Lab.	No.5 Shielded Room
Date	March 1, 2013	
Temperature / Humidity	22 deg.C , 31 %RH	
Engineer	Tatsuya Arai	
Mode	Tx, Bluetooth, EDR, PRBS9	

Mode	Number of Channel [times]	Limit [times]
3-DH5	79	>= 15

\* Test was not performed at AFH mode whose number of hopping channel is 20 channels because this Bluetooth radio is in compliance of Bluetooth Specification.

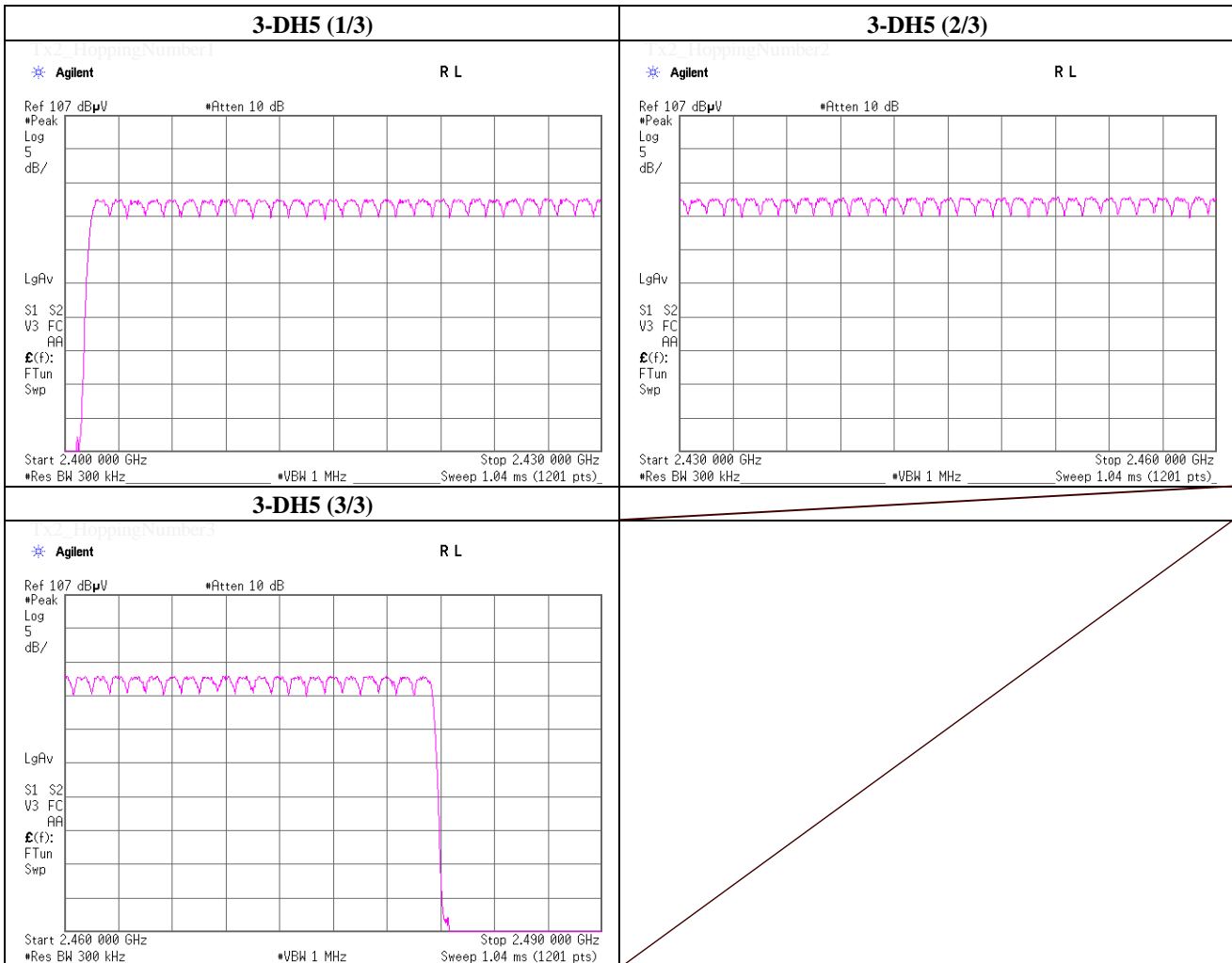

**UL Japan, Inc.**  
**Shonan EMC Lab.**  
 1-22-3 Megumigaoka, Hiratsuka-shi, Kanagawa 259-1220 JAPAN  
 Telephone : +81 463 50 6400  
 Facsimile : +81 463 50 6401

### Number of Hopping Frequency

Test place	UL Japan, Inc. Shonan EMC Lab.	No.3 Shielded Room
Date	March 1, 2013	
Temperature / Humidity	22 deg.C , 31 %RH	
Engineer	Tatsuya Arai	
Mode	Tx, Bluetooth, Inquiry	

Mode	Number of Channel [times]	Limit [times]
Inquiry	32	>= 15

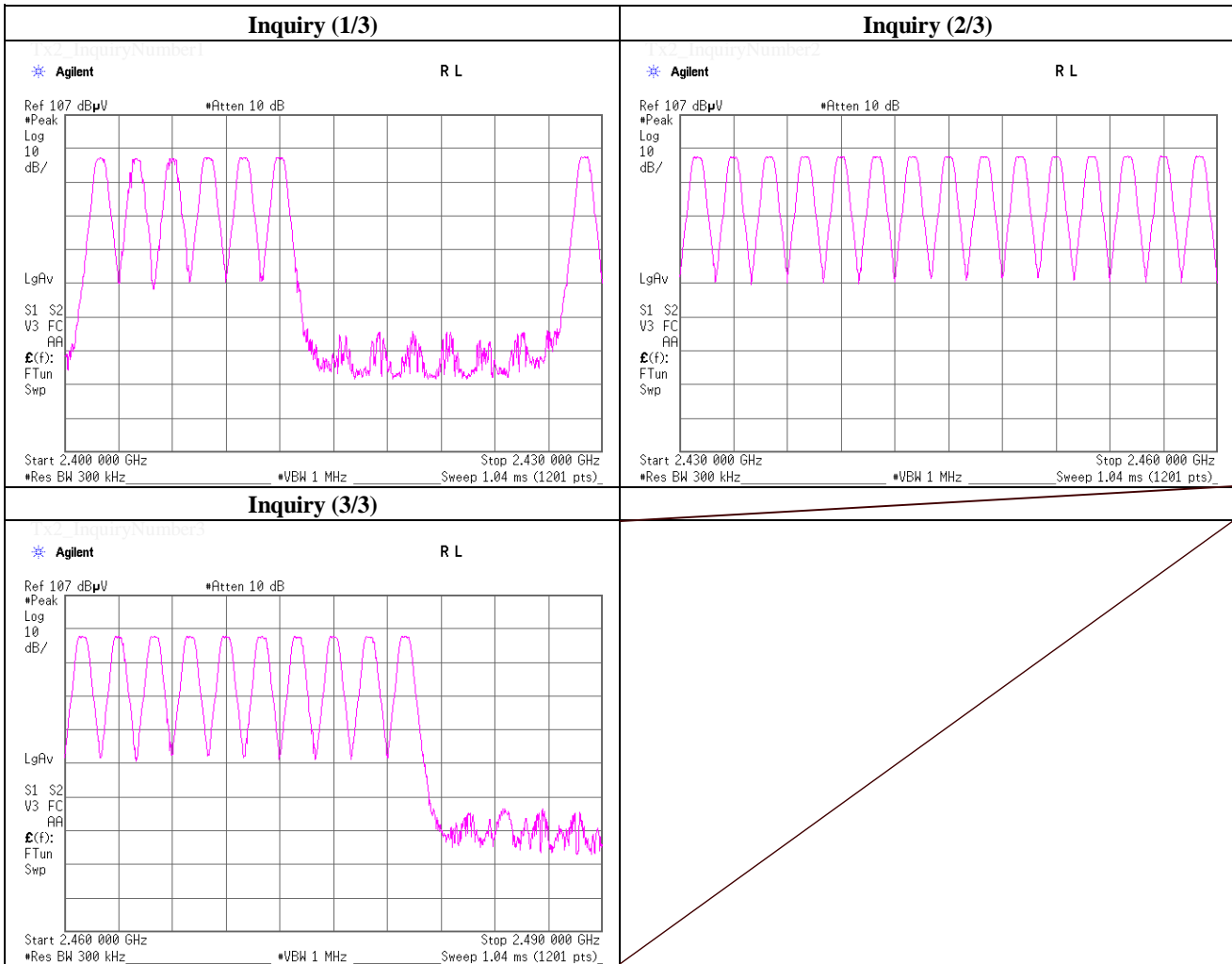

**UL Japan, Inc.**  
**Shonan EMC Lab.**  
 1-22-3 Megumigaoka, Hiratsuka-shi, Kanagawa 259-1220 JAPAN  
 Telephone : +81 463 50 6400  
 Facsimile : +81 463 50 6401

## Dwell Time

Test place	UL Japan, Inc. Shonan EMC Lab.	No.3 Shielded Room
Date	March 1, 2013	
Temperature / Humidity	22 deg.C , 31 %RH	
Engineer	Tatsuya Arai	
Mode	Tx, Bluetooth, BDR, PRBS9	

Mode	Number of transmission in a 31.6 (79 Hopping x 0.4) / 12.8 (32 Hopping x 0.4) second period	Length of transmission time [msec]	Result [msec]	Limit [msec]
DH1	49.8 / 5.0 sec. x 31.6 sec. = 315 times	0.387	122	400
DH3	25.4 / 5.0 sec. x 31.6 sec. = 161 times	1.643	265	400
DH5	19.0 / 5.0 sec. x 31.6 sec. = 121 times	2.891	350	400
Inquiry	100.0 / 1.0 sec. x 12.8 sec. = 1280 times	0.093	119	400

Sample Calculation

Result = Number of transmission x Length of transmission time

\*Average data of 5 tests.(except Inquiry)

Mode	Sampling [times]					Average [times]
	1	2	3	4	5	
DH1	49	49	50	51	50	49.8
DH3	27	27	25	26	22	25.4
DH5	18	15	18	21	23	19.0
Inquiry	100	-	-	-	-	100.0

Sample Calculation

Average= Summation(Sampling 1 to 5) / 5

\* This device complies with the Bluetooth protocol for FHSS operation, employing a pseudo random channel selection and hopping rate to ensure that the occupancy time in  $N \times 0.4s$ , where  $N$  is the number of channels being used in the hopping sequence ( $20 \leq N \leq 79$ ), is always less than 0.4s regardless of packet size (DH1, DH3 or DH5). This is confirmed in the test report for  $N=79$ .

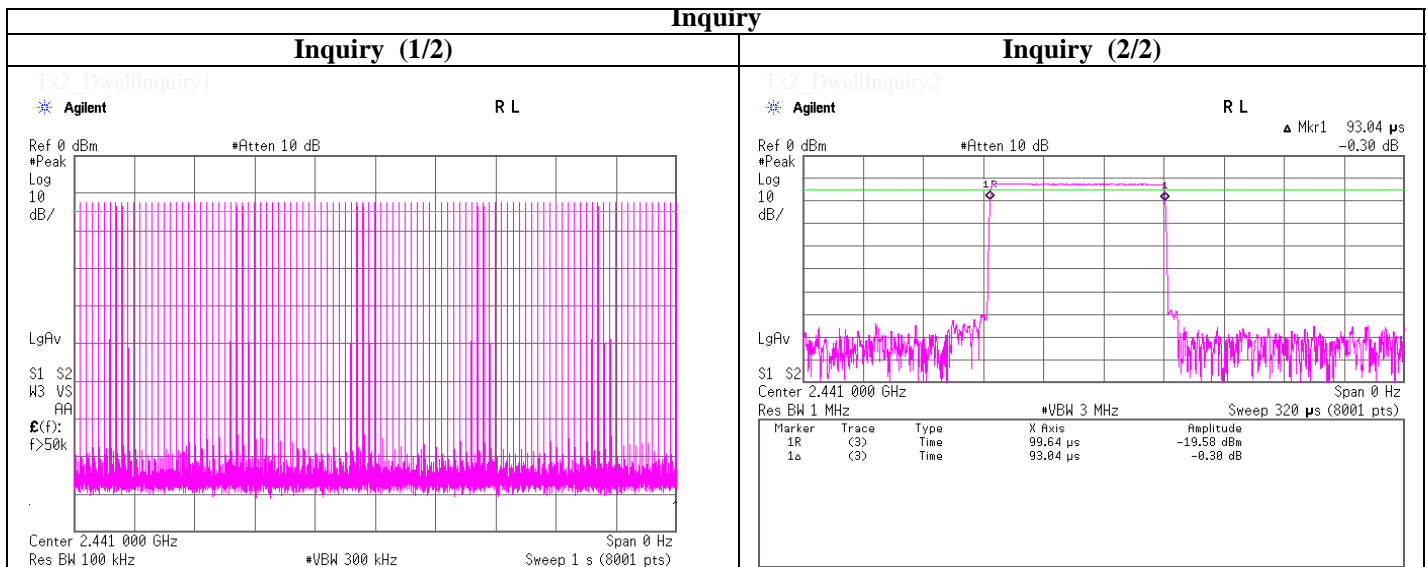

**UL Japan, Inc.**

**Shonan EMC Lab.**

1-22-3 Megumigaoka, Hiratsuka-shi, Kanagawa 259-1220 JAPAN

Telephone : +81 463 50 6400

Facsimile : +81 463 50 6401

## Dwell time

**Tx, Bluetooth, BDR, PRBS9**

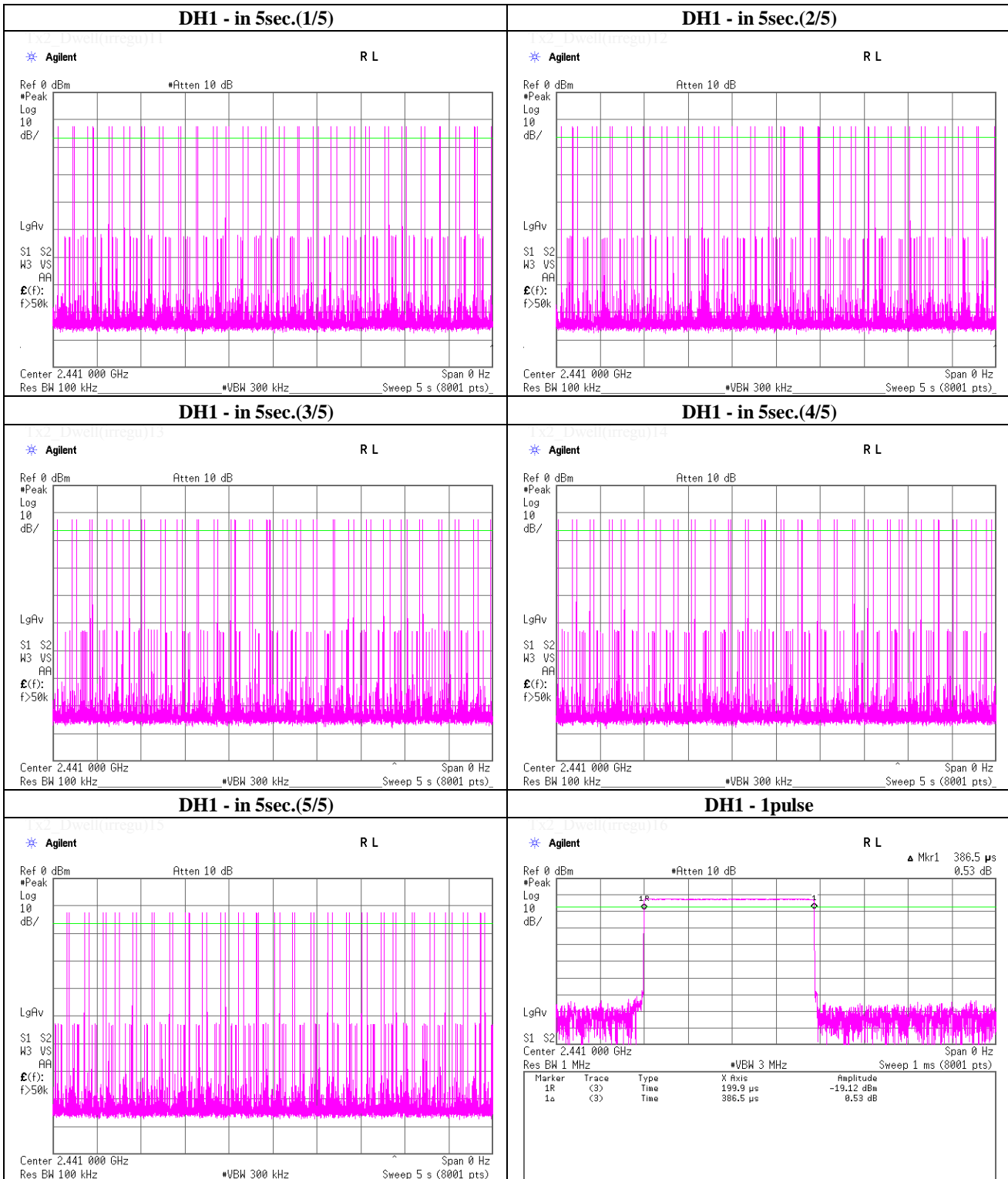

**UL Japan, Inc.**

**Shonan EMC Lab.**

1-22-3 Megumigaoka, Hiratsuka-shi, Kanagawa 259-1220 JAPAN

Telephone : +81 463 50 6400

Facsimile : +81 463 50 6401

## Dwell time

**Tx, Bluetooth, BDR, PRBS9**

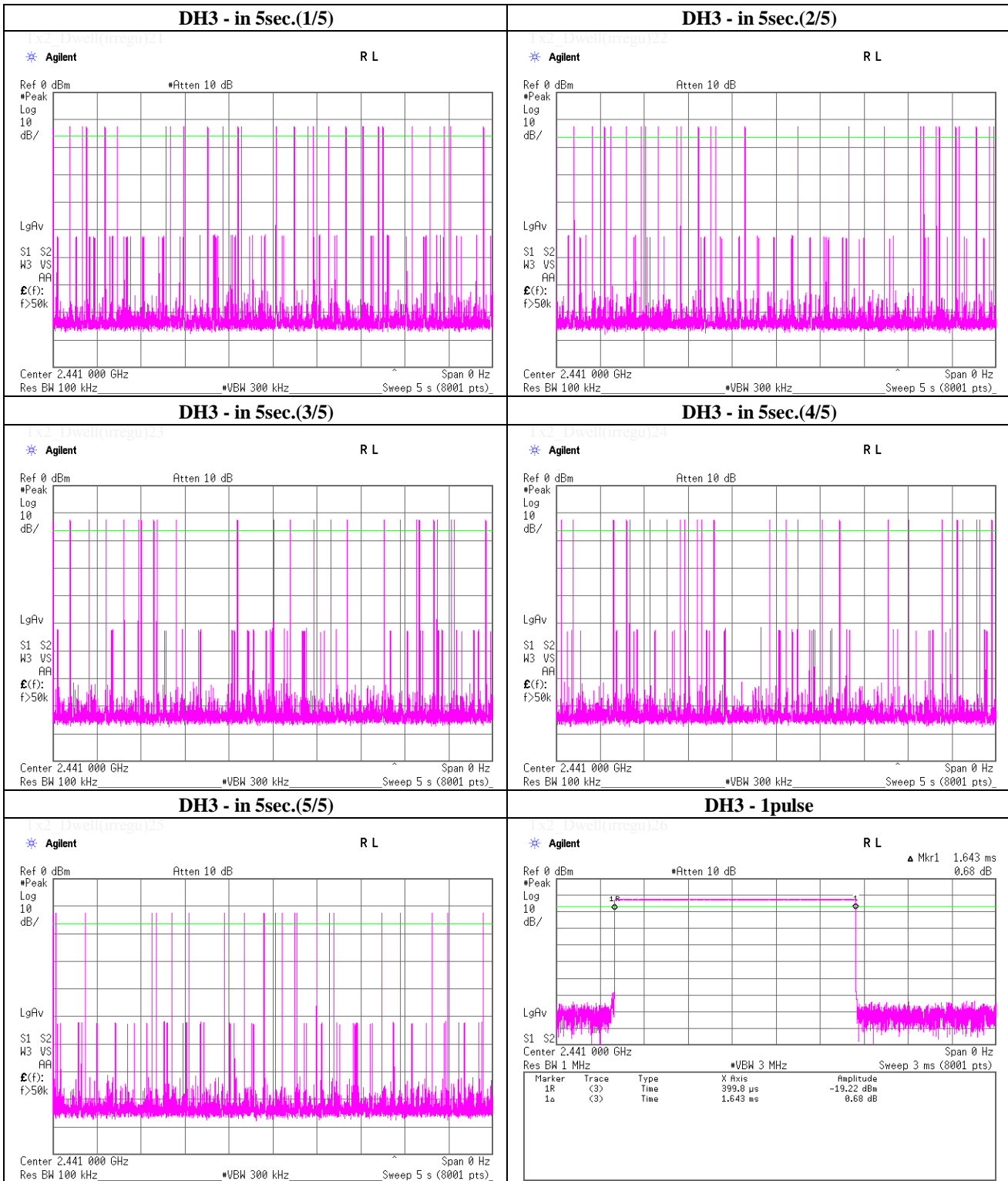

**UL Japan, Inc.**

**Shonan EMC Lab.**

1-22-3 Megumigaoka, Hiratsuka-shi, Kanagawa 259-1220 JAPAN

Telephone : +81 463 50 6400

Facsimile : +81 463 50 6401

## Dwell time

**Tx, Bluetooth, BDR, PRBS9**

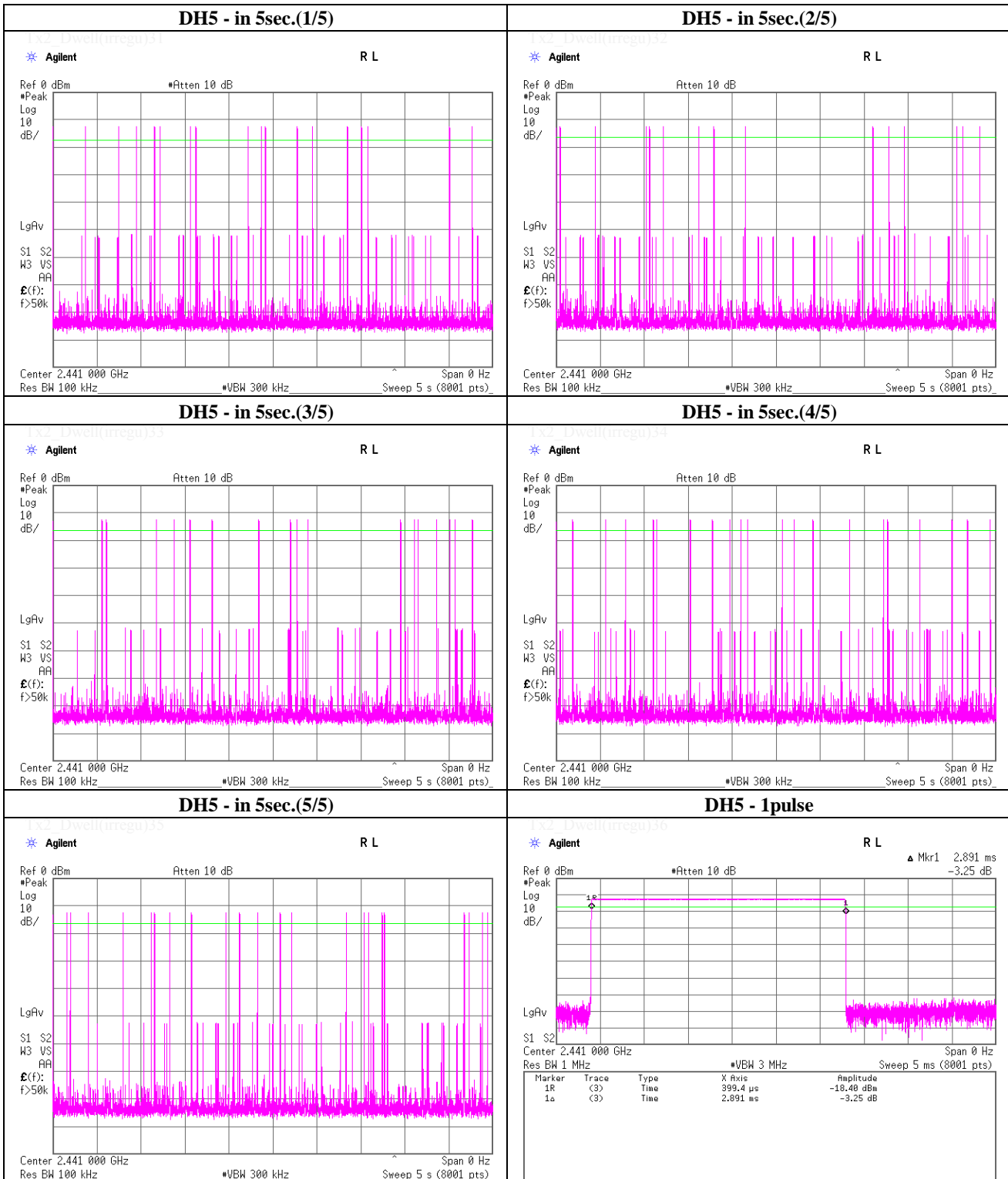

**UL Japan, Inc.**

**Shonan EMC Lab.**

1-22-3 Megumigaoka, Hiratsuka-shi, Kanagawa 259-1220 JAPAN

Telephone : +81 463 50 6400

Facsimile : +81 463 50 6401

## Dwell Time

Test place                   UL Japan, Inc. Shonan EMC Lab.                   No.5 Shielded Room  
 Date                         March 1, 2013  
 Temperature / Humidity   22 deg.C   , 31 %RH  
 Engineer                    Tatsuya Arai  
 Mode                         Tx, Bluetooth, EDR, PRBS9

Mode	Number of transmission in a 31.6 (79 Hopping x 0.4) second	Length of transmission time [msec]	Result [msec]	Limit [msec]
3-DH1	50.0 / 5.0 sec. x 31.6 sec. = 316 times	0.388	122	400
3-DH3	25.2 / 5.0 sec. x 31.6 sec. = 160 times	1.636	262	400
3-DH5	19.2 / 5.0 sec. x 31.6 sec. = 122 times	2.884	352	400

Sample Calculation

Result = Number of transmission x Length of transmission time

\*Average data of 5 tests.(except Inquiry)

Mode	Sampling [times]					Average [times]
	1	2	3	4	5	
3-DH1	50	50	50	50	50	50.0
3-DH3	27	26	26	23	24	25.2
3-DH5	17	22	18	20	19	19.2

Sample Calculation

Average= Summation(Sampling 1 to 5) / 5

\* This device complies with the Bluetooth protocol for FHSS operation, employing a pseudo random channel selection and hopping rate to ensure that the occupancy time in  $N \times 0.4s$ , where  $N$  is the number of channels being used in the hopping sequence ( $20 \leq N \leq 79$ ), is always less than 0.4s regardless of packet size (3-DH1, 3-DH3 or 3-DH5). This is confirmed in the test report for  $N=79$ .

**UL Japan, Inc.**

**Shonan EMC Lab.**

1-22-3 Megumigaoka, Hiratsuka-shi, Kanagawa 259-1220 JAPAN

Telephone : +81 463 50 6400

Facsimile : +81 463 50 6401

## Dwell time

**Tx, Bluetooth, EDR, PRBS9**

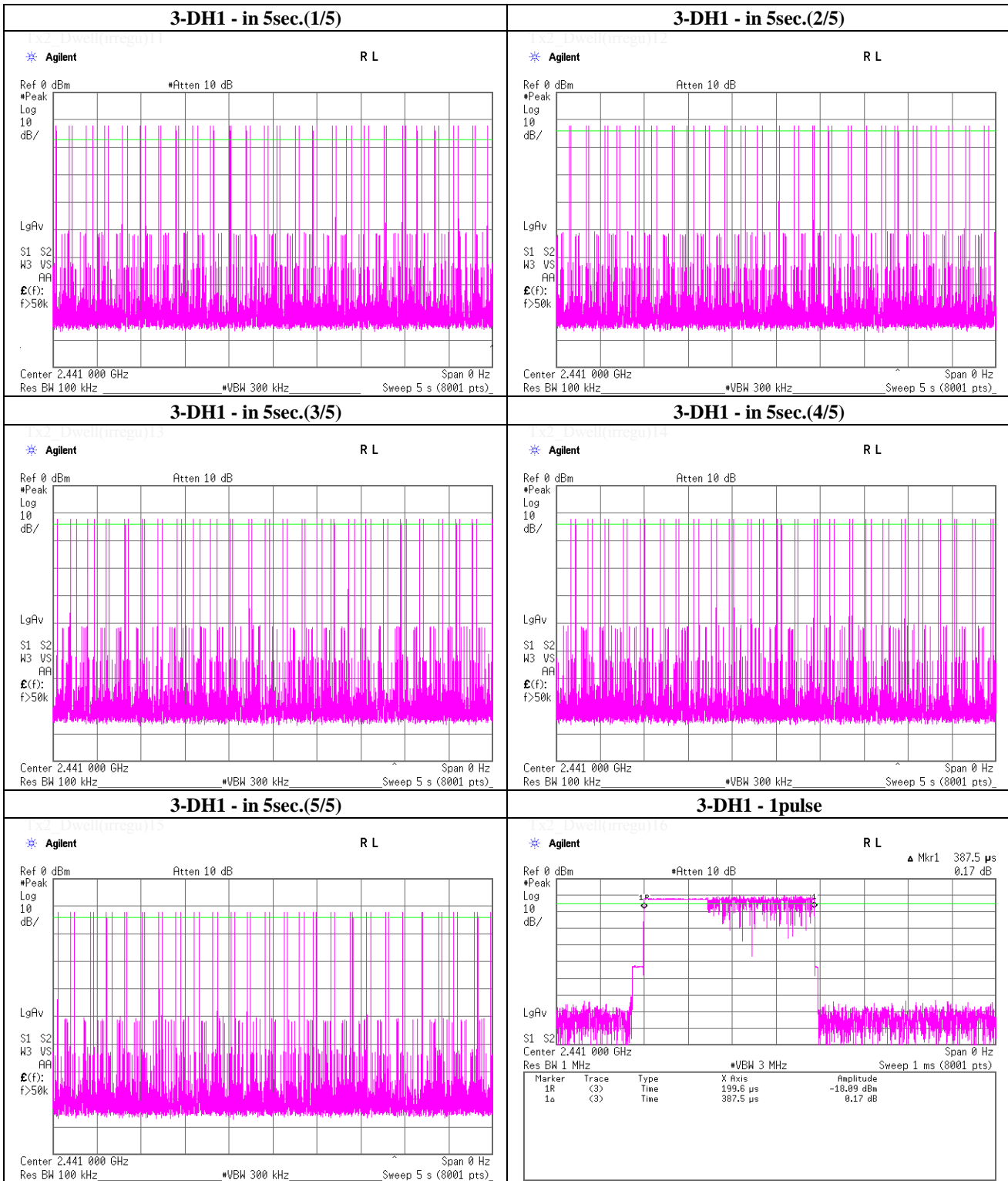

**UL Japan, Inc.**

**Shonan EMC Lab.**

1-22-3 Megumigaoka, Hiratsuka-shi, Kanagawa 259-1220 JAPAN

Telephone : +81 463 50 6400

Facsimile : +81 463 50 6401

## Dwell time

**Tx, Bluetooth, EDR, PRBS9**

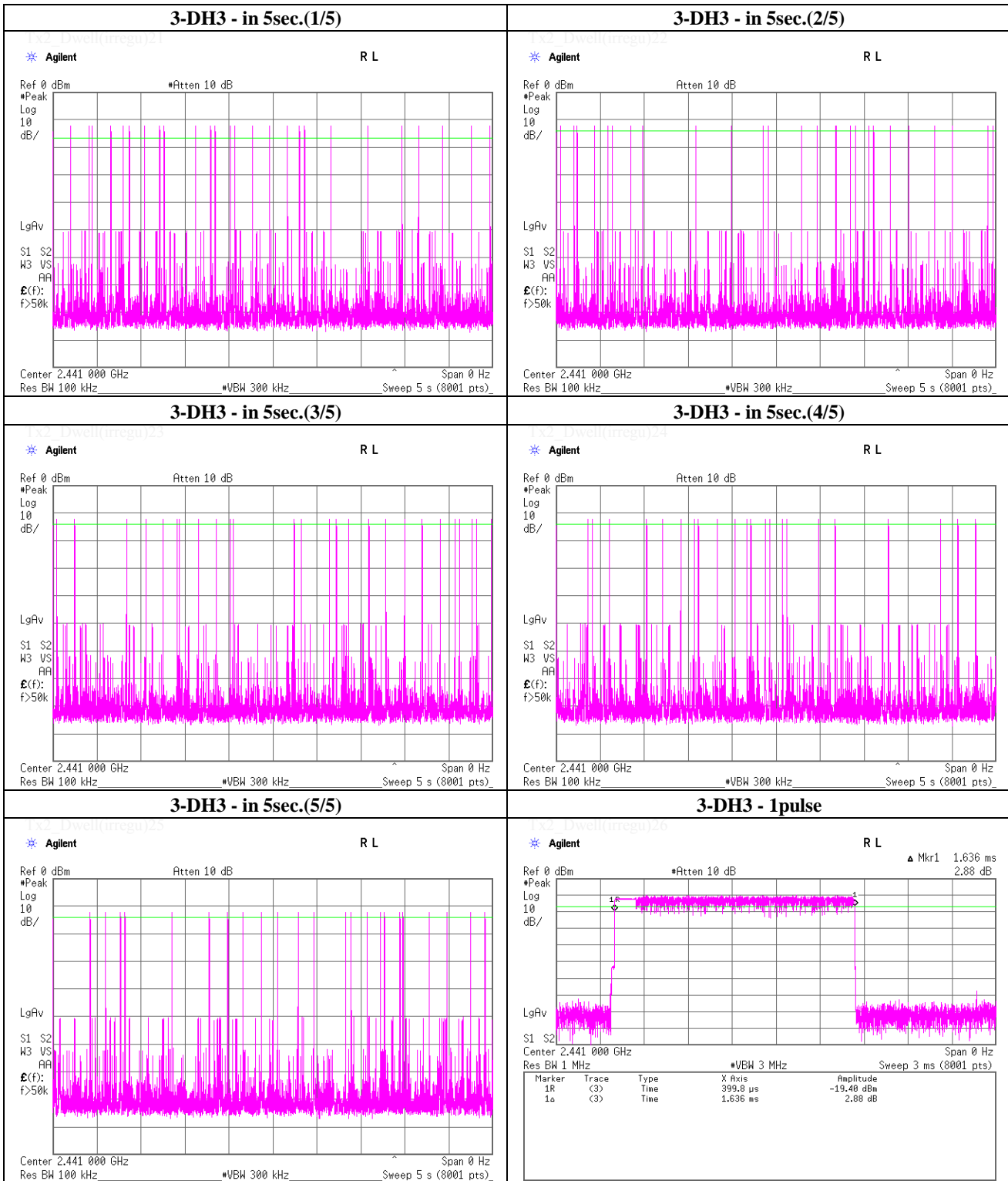

**UL Japan, Inc.**

**Shonan EMC Lab.**

1-22-3 Megumigaoka, Hiratsuka-shi, Kanagawa 259-1220 JAPAN

Telephone : +81 463 50 6400

Facsimile : +81 463 50 6401

## Dwell time

**Tx, Bluetooth, EDR, PRBS9**

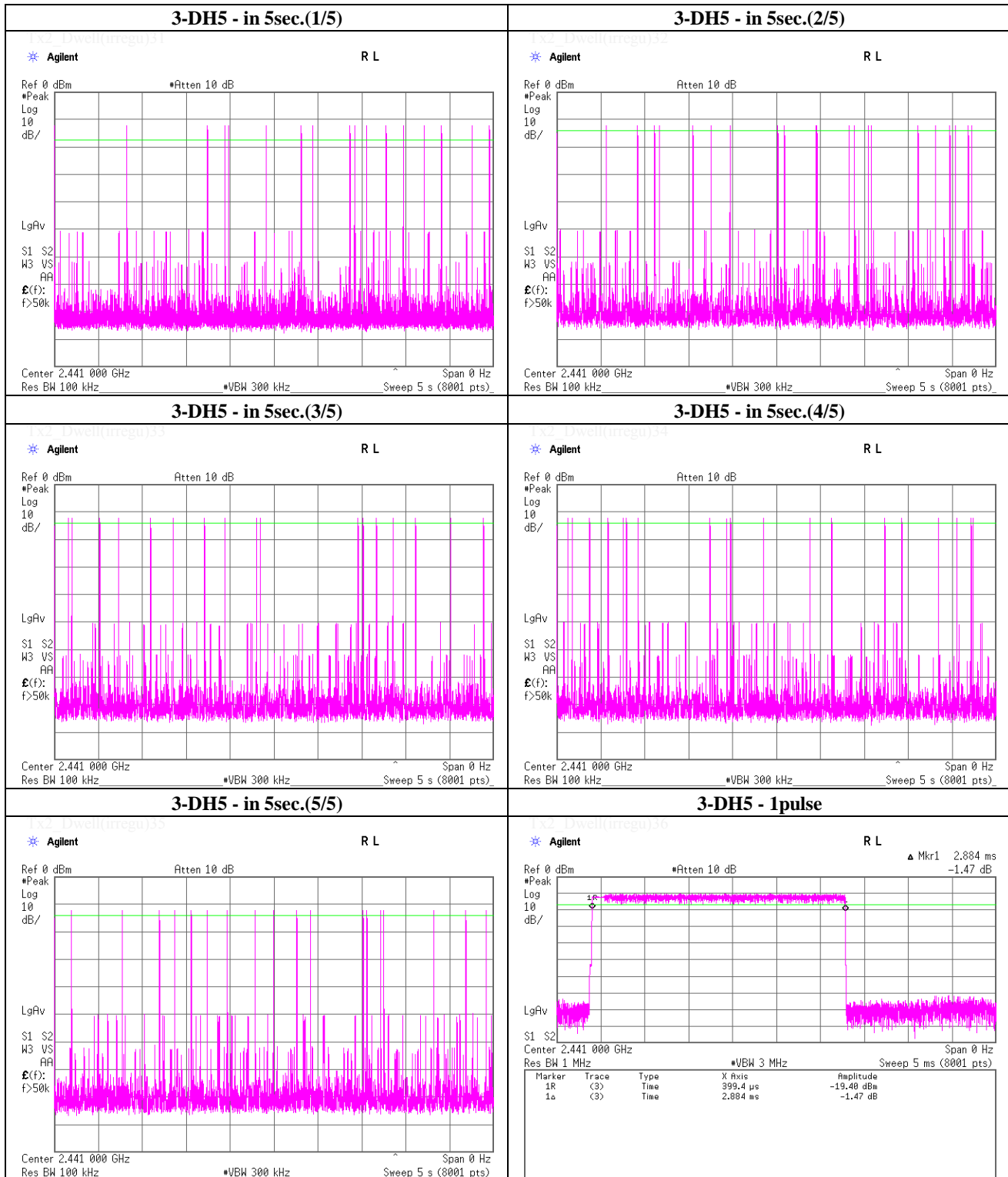

**UL Japan, Inc.**

**Shonan EMC Lab.**

1-22-3 Megumigaoka, Hiratsuka-shi, Kanagawa 259-1220 JAPAN

Telephone : +81 463 50 6400

Facsimile : +81 463 50 6401

## Maximum Peak Conducted Output Power (Conducted)

Test place                   UL Japan, Inc. Shonan EMC Lab.     No.3 Shielded Room  
 Date                         March 1, 2013  
 Temperature / Humidity    22 deg.C     , 31 %RH  
 Engineer                    Tatsuya Arai  
 Mode                        Tx, Bluetooth

(\* P/M: Power Meter with power sensor)

	Freq. [MHz]	P/M (Peak) Reading [dBm]	Cable Loss [dB]	Atten. Loss [dB]	Result		Limit		Margin [dB]
					[dBm]	[mW]	[dBm]	[mW]	
DH5	2402.0	-12.27	1.48	10.00	-0.79	0.83	20.97	125	21.76
DH5	2441.0	-12.05	1.49	10.00	-0.56	0.88	20.97	125	21.53
DH5	2480.0	-11.94	1.50	10.00	-0.44	0.90	20.97	125	21.41
2-DH5	2402.0	-10.15	1.48	10.00	1.33	1.36	20.97	125	19.64
2-DH5	2441.0	-9.98	1.49	10.00	1.51	1.42	20.97	125	19.46
2-DH5	2480.0	-9.89	1.50	10.00	1.61	1.45	20.97	125	19.36
3-DH5	2402.0	-9.78	1.48	10.00	1.70	1.48	20.97	125	19.27
3-DH5	2441.0	-9.61	1.49	10.00	1.88	1.54	20.97	125	19.09
3-DH5	2480.0	-9.52	1.50	10.00	1.98	1.58	20.97	125	18.99

Sample Calculation:

Result = Reading + Cable Loss + Atten. Loss

**UL Japan, Inc.**  
**Shonan EMC Lab.**

1-22-3 Megumigaoka, Hiratsuka-shi, Kanagawa 259-1220 JAPAN

Telephone     : +81 463 50 6400

Facsimile     : +81 463 50 6401

## Radiated Emission

Test place            No.3 Semi Anechoic Chamber  
 Date                    Fenruary 27, 2013                    February 28, 2013                    March 1, 2013  
 Temperature / Humidity 23 deg.C, 51 %RH                    22 deg.C, 52 %RH                    22 deg.C, 38 %RH  
 Engineer                Wataru Kojima                        Wataru Kojima                        Wataru Kojima  
 Mode                    Tx,                    2402 MHz  
                               Tx, Bluetooth, BDR, PRBS9                    Antenna: NIKYYYY00019

(\* PK: Peak, AV: Average, QP: Quasi-Peak)

Polarity	Frequency [MHz]	Detector	Reading [dBuV]	Ant.Fac. [dB/m]	Loss [dB]	Gain [dB]	Result [dBuV/m]	Limit [dBuV/m]	Margin [dB]	Height [cm]	Angle [deg]	Remark
Hori.	130.000	QP	27.5	13.7	7.4	32.1	16.5	43.5	27.0	226	20	
Hori.	182.004	QP	31.0	15.8	7.7	32.1	22.4	43.5	21.1	174	162	
Hori.	2390.000	PK	46.0	27.4	14.2	41.4	46.2	73.9	27.7	100	345	
Hori.	4804.000	PK	49.7	31.1	6.8	41.2	46.4	73.9	27.5	100	226	
Hori.	7206.000	PK	53.5	36.6	8.3	41.4	57.0	73.9	<b>16.9</b>	103	327	
Hori.	9608.000	PK	46.0	38.5	9.5	38.9	55.1	73.9	18.8	110	248	
Hori.	12010.000	PK	43.8	39.4	10.9	39.4	54.7	73.9	19.2	100	0	
Vert.	130.000	QP	32.3	13.7	7.4	32.1	21.3	43.5	22.2	100	141	
Vert.	182.004	QP	28.8	15.8	7.7	32.1	20.2	43.5	23.3	100	229	
Vert.	2390.000	PK	46.0	27.4	14.2	41.4	46.2	73.9	27.7	117	159	
Vert.	4804.000	PK	47.2	31.1	6.8	41.2	43.9	73.9	30.0	100	53	
Vert.	7206.000	PK	52.9	36.6	8.3	41.4	56.4	73.9	17.5	120	9	
Vert.	9608.000	PK	45.8	38.5	9.5	38.9	54.9	73.9	19.0	140	16	
Vert.	12010.000	PK	44.8	39.4	10.9	39.4	55.7	73.9	18.2	100	0	

Result = Reading + Ant.Fac. + Loss (Cable+Attenuator+Filter-Distance factor(above 15GHz)) - Gain(Amplifier)

Distance factor : 15GHz -40GHz : 20log(3.0m/1.0m)= 9.5dB

\*Other frequency noises omitted in this report were not seen or have enough margin (more than 20dB).

**Dwell time factor relaxatio**

Polarity	Frequency [MHz]	Detector	Reading [dBuV]	Ant.Fac. [dB/m]	Loss [dB]	Gain [dB]	Dwell Factor [dB]	Result [dBuV/m]	Limit [dBuV/m]	Margin [dB]	Remark
Hori.	2390.000	AV	34.5	27.4	14.2	41.4	-24.8	9.9	53.9	44.0	VBW: 10Hz
Hori.	4804.000	AV	42.2	31.1	6.8	41.2	-24.8	14.1	53.9	39.8	VBW: 10Hz
Hori.	7206.000	AV	46.0	36.6	8.3	41.4	-24.8	24.7	53.9	<b>29.2</b>	VBW: 10Hz
Hori.	9608.000	AV	34.6	38.5	9.5	38.9	-24.8	18.9	53.9	35.0	VBW: 10Hz
Hori.	12010.000	AV	33.2	39.4	10.9	39.4	-24.8	19.3	53.9	34.6	VBW: 10Hz
Vert.	2390.000	AV	34.5	27.4	14.2	41.4	-24.8	9.9	53.9	44.0	VBW: 10Hz
Vert.	4804.000	AV	36.9	31.1	6.8	41.2	-24.8	8.8	53.9	45.1	VBW: 10Hz
Vert.	7206.000	AV	44.6	36.6	8.3	41.4	-24.8	23.3	53.9	30.6	VBW: 10Hz
Vert.	9608.000	AV	34.6	38.5	9.5	38.9	-24.8	18.9	53.9	35.0	VBW: 10Hz
Vert.	12010.000	AV	33.2	39.4	10.9	39.4	-24.8	19.3	53.9	34.6	VBW: 10Hz

Result = Reading + Ant.Fac. + Loss(Cable+Attenuator+Filter-Distance factor(above 15GHz)) - Gain(Amplifier) + Dwell(time)factor

Distance factor : 15GHz -40GHz : 20log(3.0m/1.0m)= 9.5dB

\*Other frequency noises omitted in this report were not seen or have enough margin (more than 20dB).

**20dBc Data Sheet (RBW 100kHz, VBW 300kHz)**

Polarity	Frequency [MHz]	Detector	Reading [dBuV]	Ant.Fac. [dB/m]	Loss [dB]	Gain [dB]	Result [dBuV/m]	Limit [dBuV/m]	Margin [dB]	Remark
Hori.	2402.000	PK	90.4	27.4	14.2	41.4	90.6	-	-	
Hori.	2400.000	PK	37.3	27.4	14.2	41.4	37.5	70.6	33.1	
Vert.	2402.000	PK	89.2	27.4	14.2	41.4	89.4	-	-	
Vert.	2400.000	PK	37.0	27.4	14.2	41.4	37.2	69.4	32.2	

Result = Reading + Ant.Fac. + Loss(Cable+Attenuator+Filter) - Gain(Amplifier)

**UL Japan, Inc.****Shonan EMC Lab.**

1-22-3 Megumigaoka, Hiratsuka-shi, Kanagawa 259-1220 JAPAN

Telephone : +81 463 50 6400

Facsimile : +81 463 50 6401

## Radiated Emission

Test place            No.3 Semi Anechoic Chamber  
 Date                    Fenruary 26, 2013            Fenruary 27, 2013            February 28, 2013            March 1, 2013  
 Temperature / Humidity 22 deg.C, 38 %RH            23 deg.C, 51 %RH            22 deg.C, 52 %RH            22 deg.C, 38 %RH  
 Engineer               Makoto Hosaka               Wataru Kojima               Makoto Hosaka               Wataru Kojima  
 Mode                    Tx,                    2441 MHz  
                              Tx, Bluetooth, BDR, PRBS9                    Antenna: NIKYYYY00019

(\* PK: Peak, AV: Average, QP: Quasi-Peak)

Polarity	Frequency [MHz]	Detector	Reading [dBuV]	Ant.Fac. [dB/m]	Loss [dB]	Gain [dB]	Result [dBuV/m]	Limit [dBuV/m]	Margin [dB]	Height [cm]	Angle [deg]	Remark
Hori.	130.000	QP	27.3	13.7	7.4	32.1	16.3	43.5	27.2	219	13	
Hori.	182.004	QP	31.1	15.8	7.7	32.1	22.5	43.5	21.0	200	181	
Hori.	4882.000	PK	51.1	31.3	6.9	41.1	48.2	73.9	25.7	100	219	
Hori.	7323.000	PK	53.6	36.6	8.4	41.4	57.2	73.9	16.7	100	327	
Hori.	9764.000	PK	48.2	38.7	9.5	38.9	57.5	73.9	16.4	105	19	
Hori.	12205.000	PK	44.6	39.5	10.9	39.3	55.7	73.9	18.2	100	0	
Vert.	130.003	QP	32.2	13.7	7.4	32.1	21.2	43.5	22.3	100	155	
Vert.	182.000	QP	30.2	15.8	7.7	32.1	21.6	43.5	21.9	100	210	
Vert.	4882.000	PK	48.2	31.3	6.9	41.1	45.3	73.9	28.6	100	44	
Vert.	7323.000	PK	54.4	36.6	8.4	41.4	58.0	73.9	<b>15.9</b>	135	24	
Vert.	9764.000	PK	46.6	38.7	9.5	38.9	55.9	73.9	18.0	100	334	
Vert.	12205.000	PK	43.7	39.5	10.9	39.3	54.8	73.9	19.1	100	0	

Result = Reading + Ant.Fac. + Loss (Cable+Attenuator+Filter-Distance factor(above 15GHz)) - Gain(Amplifier)

Distance factor : 15GHz -40GHz : 20log(3.0m/1.0m)= 9.5dB

\*Other frequency noises omitted in this report were not seen or have enough margin (more than 20dB).

**Dwell time factor relaxatio**

Polarity	Frequency [MHz]	Detector	Reading [dBuV]	Ant.Fac. [dB/m]	Loss [dB]	Gain [dB]	Dwell Factor [dB]	Result [dBuV/m]	Limit [dBuV/m]	Margin [dB]	Remark
Hori.	4882.000	AV	43.9	31.3	6.9	41.1	-24.8	16.2	53.9	37.7	VBW: 10Hz
Hori.	7323.000	AV	45.5	36.6	8.4	41.4	-24.8	24.3	53.9	29.6	VBW: 10Hz
Hori.	9764.000	AV	36.9	38.7	9.5	38.9	-24.8	21.4	53.9	32.5	VBW: 10Hz
Hori.	12205.000	AV	32.8	39.5	10.9	39.3	-24.8	19.1	53.9	34.8	VBW: 10Hz
Vert.	4882.000	AV	39.3	31.3	6.9	41.1	-24.8	11.6	53.9	42.3	VBW: 10Hz
Vert.	7323.000	AV	47.0	36.6	8.4	41.4	-24.8	25.8	53.9	<b>28.1</b>	VBW: 10Hz
Vert.	9764.000	AV	35.6	38.7	9.5	38.9	-24.8	20.1	53.9	33.8	VBW: 10Hz
Vert.	12205.000	AV	32.7	39.5	10.9	39.3	-24.8	19.0	53.9	34.9	VBW: 10Hz

Result = Reading + Ant.Fac. + Loss(Cable+Attenuator+Filter-Distance factor(above 15GHz)) - Gain(Amplifier) + Dwell(time)factor

Distance factor : 15GHz -40GHz : 20log(3.0m/1.0m)= 9.5dB

\*Other frequency noises omitted in this report were not seen or have enough margin (more than 20dB).

**UL Japan, Inc.****Shonan EMC Lab.**

1-22-3 Megumigaoka, Hiratsuka-shi, Kanagawa 259-1220 JAPAN

Telephone : +81 463 50 6400

Facsimile : +81 463 50 6401

## Radiated Emission

Test place            No.3 Semi Anechoic Chamber  
Date                    Fenruary 27, 2013                    February 28, 2013                    March 1, 2013  
Temperature / Humidity 23 deg.C, 51 %RH                    22 deg.C, 52 %RH                    22 deg.C, 38 %RH  
Engineer                Wataru Kojima                        Wataru Kojima                        Wataru Kojima  
Mode                    Tx,                    2480 MHz  
                             Tx, Bluetooth, BDR, PRBS9                    Antenna: NIKYYYY00019

(\* PK: Peak, AV: Average, QP: Quasi-Peak)

Polarity	Frequency [MHz]	Detector	Reading [dBuV]	Ant.Fac. [dB/m]	Loss [dB]	Gain [dB]	Result [dBuV/m]	Limit [dBuV/m]	Margin [dB]	Height [cm]	Angle [deg]	Remark
Hori.	130.000	QP	27.8	13.7	7.4	32.1	16.8	43.5	26.7	221	18	
Hori.	182.005	QP	31.6	15.8	7.7	32.1	23.0	43.5	20.5	180	181	
Hori.	2483.500	PK	47.8	27.5	14.3	41.4	48.2	73.9	25.7	100	347	
Hori.	4960.000	PK	53.6	31.6	6.9	41.0	51.1	73.9	22.8	100	226	
Hori.	7440.000	PK	55.3	36.7	8.5	41.5	59.0	73.9	14.9	100	327	
Hori.	9920.000	PK	45.5	39.0	9.7	38.9	55.3	73.9	18.6	100	52	
Hori.	12400.000	PK	45.2	39.5	10.8	39.3	56.2	73.9	17.7	100	0	
Vert.	130.003	QP	31.7	13.7	7.4	32.1	20.7	43.5	22.8	100	164	
Vert.	182.004	QP	30.5	15.8	7.7	32.1	21.9	43.5	21.6	100	205	
Vert.	2483.500	PK	46.7	27.5	14.3	41.4	47.1	73.9	26.8	100	166	
Vert.	4960.000	PK	50.0	31.6	6.9	41.0	47.5	73.9	26.4	100	51	
Vert.	7440.000	PK	54.7	36.7	8.5	41.5	58.4	73.9	15.5	121	20	
Vert.	9920.000	PK	45.0	39.0	9.7	38.9	54.8	73.9	19.1	100	62	
Vert.	12400.000	PK	45.5	39.5	10.8	39.3	56.5	73.9	17.4	100	0	

Result = Reading + Ant.Fac. + Loss (Cable+Attenuator+Filter-Distance factor(above 15GHz)) - Gain(Amplifier)

Distance factor : 15GHz -40GHz : 20log(3.0m/1.0m)= 9.5dB

\*Other frequency noises omitted in this report were not seen or have enough margin (more than 20dB).

**Dwell time factor relaxatio**

Polarity	Frequency [MHz]	Detector	Reading [dBuV]	Ant.Fac. [dB/m]	Loss [dB]	Gain [dB]	Dwell Factor [dB]	Result [dBuV/m]	Limit [dBuV/m]	Margin [dB]	Remark
Hori.	2483.500	AV	35.2	27.5	14.3	41.4	-24.8	10.8	53.9	43.1	VBW: 10Hz
Hori.	4960.000	AV	47.9	31.6	6.9	41.0	-24.8	20.6	53.9	33.3	VBW: 10Hz
Hori.	7440.000	AV	48.0	36.7	8.5	41.5	-24.8	26.9	53.9	27.0	VBW: 10Hz
Hori.	9920.000	AV	34.2	39.0	9.7	38.9	-24.8	19.2	53.9	34.7	VBW: 10Hz
Hori.	12400.000	AV	33.1	39.5	10.8	39.3	-24.8	19.3	53.9	34.6	VBW: 10Hz
Vert.	2483.500	AV	35.2	27.5	14.3	41.4	-24.8	10.8	53.9	43.1	VBW: 10Hz
Vert.	4960.000	AV	42.1	31.6	6.9	41.0	-24.8	14.8	53.9	39.1	VBW: 10Hz
Vert.	7440.000	AV	47.1	36.7	8.5	41.5	-24.8	26.0	53.9	27.9	VBW: 10Hz
Vert.	9920.000	AV	33.8	39.0	9.7	38.9	-24.8	18.8	53.9	35.1	VBW: 10Hz
Vert.	12400.000	AV	33.1	39.5	10.8	39.3	-24.8	19.3	53.9	34.6	VBW: 10Hz

Result = Reading + Ant.Fac. + Loss(Cable+Attenuator+Filter-Distance factor(above 15GHz)) - Gain(Amplifier) + Dwell(time)factor

Distance factor : 15GHz -40GHz : 20log(3.0m/1.0m)= 9.5dB

\*Other frequency noises omitted in this report were not seen or have enough margin (more than 20dB).

**UL Japan, Inc.****Shonan EMC Lab.**

1-22-3 Megumigaoka, Hiratsuka-shi, Kanagawa 259-1220 JAPAN

Telephone : +81 463 50 6400

Facsimile : +81 463 50 6401

## Radiated Emission

Test place No.3 Semi Anechoic Chamber  
 Date February 27, 2013      February 27, 2013      February 28, 2013      March 1, 2013  
 Temperature / Humidity 23 deg.C, 51 %RH      23 deg.C, 51 %RH      22 deg.C, 52 %RH      22 deg.C, 38 %RH  
 Engineer Makoto Hosaka      Wataru Kojima      Makoto Hosaka      Wataru Kojima  
 Mode Tx, 2402 MHz  
 Tx, Bluetooth, EDR, PRBS9      Antenna: NIKYYYY00019

(\* PK: Peak, AV: Average, QP: Quasi-Peak)

Polarity	Frequency [MHz]	Detector	Reading [dBuV]	Ant.Fac. [dB/m]	Loss [dB]	Gain [dB]	Result [dBuV/m]	Limit [dBuV/m]	Margin [dB]	Height [cm]	Angle [deg]	Remark
Hori.	130.000	QP	28.0	13.7	7.4	32.1	17.0	43.5	26.5	234	28	
Hori.	182.006	QP	31.9	15.8	7.7	32.1	23.3	43.5	20.2	174	174	
Hori.	2362.200	PK	48.4	27.4	14.1	41.4	48.5	73.9	25.4	100	0	
Hori.	2385.296	PK	51.6	27.4	14.2	41.4	51.8	73.9	22.1	100	0	
Hori.	2390.000	PK	46.8	27.4	14.2	41.4	47.0	73.9	26.9	100	0	
Hori.	4804.000	PK	57.4	31.1	6.8	41.2	54.1	73.9	19.8	100	223	
Hori.	7206.000	PK	52.7	36.6	8.3	41.4	56.2	73.9	17.7	135	325	
Hori.	9608.000	PK	47.5	38.5	9.5	38.9	56.6	73.9	17.3	120	27	
Hori.	12010.000	PK	45.9	39.4	10.9	39.4	56.8	73.9	17.1	100	0	
Hori.	2362.200	AV	36.7	27.4	14.1	41.4	36.8	53.9	17.1	100	0	VBW: 10Hz
Hori.	2385.296	AV	34.1	27.4	14.2	41.4	34.3	53.9	19.6	100	0	VBW: 10Hz
Vert.	130.004	QP	31.6	13.7	7.4	32.1	20.6	43.5	22.9	100	150	
Vert.	182.006	QP	30.5	15.8	7.7	32.1	21.9	43.5	21.6	100	211	
Vert.	2362.200	PK	49.3	27.4	14.1	41.4	49.4	73.9	24.5	110	68	
Vert.	2385.296	PK	52.7	27.4	14.2	41.4	52.9	73.9	21.0	110	68	
Vert.	2390.000	PK	47.8	27.4	14.2	41.4	48.0	73.9	25.9	110	68	
Vert.	4804.000	PK	53.8	31.1	6.8	41.2	50.5	73.9	23.4	100	54	
Vert.	7206.000	PK	53.0	36.6	8.3	41.4	56.5	73.9	17.4	152	19	
Vert.	9608.000	PK	49.3	38.5	9.5	38.9	58.4	73.9	15.5	158	0	
Vert.	12010.000	PK	45.3	39.4	10.9	39.4	56.2	73.9	17.7	100	0	
Vert.	2362.200	AV	37.4	27.4	14.1	41.4	37.5	53.9	16.4	110	68	VBW: 10Hz
Vert.	2385.296	AV	34.1	27.4	14.2	41.4	34.3	53.9	19.6	110	68	VBW: 10Hz

Result = Reading + Ant.Fac. + Loss (Cable+Attenuator+Filter-Distance factor(above 15GHz)) - Gain(Amplifier)

Distance factor : 15GHz -40GHz : 20log(3.0m/1.0m)= 9.5dB

\*Other frequency noises omitted in this report were not seen or have enough margin (more than 20dB).

**Dwell time factor relaxatio**

Polarity	Frequency [MHz]	Detector	Reading [dBuV]	Ant.Fac. [dB/m]	Loss [dB]	Gain [dB]	Dwell Factor [dB]	Result [dBuV/m]	Limit [dBuV/m]	Margin [dB]	Remark
Hori.	2390.000	AV	34.1	27.4	14.2	41.4	-24.8	9.5	53.9	44.4	VBW: 10Hz
Hori.	4804.000	AV	49.6	31.1	6.8	41.2	-24.8	21.5	53.9	32.4	VBW: 10Hz
Hori.	7206.000	AV	43.3	36.6	8.3	41.4	-24.8	22.0	53.9	31.9	VBW: 10Hz
Hori.	9608.000	AV	35.6	38.5	9.5	38.9	-24.8	19.9	53.9	34.0	VBW: 10Hz
Hori.	12010.000	AV	32.8	39.4	10.9	39.4	-24.8	18.9	53.9	35.0	VBW: 10Hz
Vert.	2390.000	AV	34.1	27.4	14.2	41.4	-24.8	9.5	53.9	44.4	VBW: 10Hz
Vert.	4804.000	AV	45.4	31.1	6.8	41.2	-24.8	17.3	53.9	36.6	VBW: 10Hz
Vert.	7206.000	AV	43.4	36.6	8.3	41.4	-24.8	22.1	53.9	31.8	VBW: 10Hz
Vert.	9608.000	AV	37.5	38.5	9.5	38.9	-24.8	21.8	53.9	32.1	VBW: 10Hz
Vert.	12010.000	AV	32.7	39.4	10.9	39.4	-24.8	18.8	53.9	35.1	VBW: 10Hz

Result = Reading + Ant.Fac. + Loss(Cable+Attenuator+Filter-Distance factor(above 15GHz)) - Gain(Amplifier) + Dwell(time)factor

Distance factor : 15GHz -40GHz : 20log(3.0m/1.0m)= 9.5dB

\*Other frequency noises omitted in this report were not seen or have enough margin (more than 20dB).

**20dBc Data Sheet (RBW 100kHz, VBW 300kHz)**

Polarity	Frequency [MHz]	Detector	Reading [dBuV]	Ant.Fac. [dB/m]	Loss [dB]	Gain [dB]	Result [dBuV/m]	Limit [dBuV/m]	Margin [dB]	Remark
Hori.	2402.000	PK	89.3	27.4	14.2	41.4	89.5	-	-	
Hori.	2400.000	PK	41.7	27.4	14.2	41.4	41.9	69.5	27.6	
Vert.	2402.000	PK	90.5	27.4	14.2	41.4	90.7	-	-	
Vert.	2400.000	PK	42.2	27.4	14.2	41.4	42.4	70.7	28.3	

Result = Reading + Ant.Fac. + Loss(Cable+Attenuator+Filter) - Gain(Amplifier)

**UL Japan, Inc.****Shonan EMC Lab.**

1-22-3 Megumigaoka, Hiratsuka-shi, Kanagawa 259-1220 JAPAN

Telephone : +81 463 50 6400

Facsimile : +81 463 50 6401

## Radiated Emission

Test place            No.3 Semi Anechoic Chamber  
 Date                    Fenruary 27, 2013                    February 28, 2013                    March 1, 2013  
 Temperature / Humidity 23 deg.C, 51 %RH                    22 deg.C, 52 %RH                    22 deg.C, 38 %RH  
 Engineer                Wataru Kojima                        Makoto Hosaka                        Wataru Kojima  
 Mode                    Tx,                    2441 MHz  
                               Tx, Bluetooth, EDR, PRBS9                    Antenna: NIKYYYY00019

(\* PK: Peak, AV: Average, QP: Quasi-Peak)

Polarity	Frequency [MHz]	Detector	Reading [dBuV]	Ant.Fac. [dB/m]	Loss [dB]	Gain [dB]	Result [dBuV/m]	Limit [dBuV/m]	Margin [dB]	Height [cm]	Angle [deg]	Remark
Hori.	130.000	QP	27.9	13.7	7.4	32.1	16.9	43.5	26.6	200	23	
Hori.	182.004	QP	30.0	15.8	7.7	32.1	21.4	43.5	22.1	200	157	
Hori.	4882.000	PK	57.5	31.3	6.9	41.1	54.6	73.9	19.3	100	226	
Hori.	7323.000	PK	54.8	36.6	8.4	41.4	58.4	73.9	15.5	100	327	
Hori.	9764.000	PK	50.9	38.7	9.5	38.9	60.2	73.9	<b>13.7</b>	112	250	
Hori.	12205.000	PK	44.2	39.5	10.9	39.3	55.3	73.9	18.6	100	0	
Vert.	130.000	QP	33.0	13.7	7.4	32.1	22.0	43.5	21.5	100	160	
Vert.	182.004	QP	29.0	15.8	7.7	32.1	20.4	43.5	23.1	100	206	
Vert.	4882.000	PK	53.8	31.3	6.9	41.1	50.9	73.9	23.0	100	42	
Vert.	7323.000	PK	52.5	36.6	8.4	41.4	56.1	73.9	17.8	105	9	
Vert.	9764.000	PK	49.1	38.7	9.5	38.9	58.4	73.9	15.5	145	75	
Vert.	12205.000	PK	45.5	39.5	10.9	39.3	56.6	73.9	17.3	100	0	

Result = Reading + Ant.Fac. + Loss (Cable+Attenuator+Filter-Distance factor(above 15GHz)) - Gain(Amplifier)

Distance factor : 15GHz -40GHz : 20log(3.0m/1.0m)= 9.5dB

\*Other frequency noises omitted in this report were not seen or have enough margin (more than 20dB).

**Dwell time factor relaxatio**

Polarity	Frequency [MHz]	Detector	Reading [dBuV]	Ant.Fac. [dB/m]	Loss [dB]	Gain [dB]	Dwell Factor [dB]	Result [dBuV/m]	Limit [dBuV/m]	Margin [dB]	Remark
Hori.	4882.000	AV	49.2	31.3	6.9	41.1	-24.8	21.5	53.9	32.4	VBW: 10Hz
Hori.	7323.000	AV	45.2	36.6	8.4	41.4	-24.8	24.0	53.9	29.9	VBW: 10Hz
Hori.	9764.000	AV	40.6	38.7	9.5	38.9	-24.8	25.1	53.9	<b>28.8</b>	VBW: 10Hz
Hori.	12205.000	AV	32.2	39.5	10.9	39.3	-24.8	18.5	53.9	35.4	VBW: 10Hz
Vert.	4882.000	AV	45.3	31.3	6.9	41.1	-24.8	17.6	53.9	36.3	VBW: 10Hz
Vert.	7323.000	AV	42.6	36.6	8.4	41.4	-24.8	21.4	53.9	32.5	VBW: 10Hz
Vert.	9764.000	AV	38.7	38.7	9.5	38.9	-24.8	23.2	53.9	30.7	VBW: 10Hz
Vert.	12205.000	AV	32.2	39.5	10.9	39.3	-24.8	18.5	53.9	35.4	VBW: 10Hz

Result = Reading + Ant.Fac. + Loss(Cable+Attenuator+Filter-Distance factor(above 15GHz)) - Gain(Amplifier) + Dwell(time)factor

Distance factor : 15GHz -40GHz : 20log(3.0m/1.0m)= 9.5dB

\*Other frequency noises omitted in this report were not seen or have enough margin (more than 20dB).

**UL Japan, Inc.****Shonan EMC Lab.**

1-22-3 Megumigaoka, Hiratsuka-shi, Kanagawa 259-1220 JAPAN

Telephone : +81 463 50 6400

Facsimile : +81 463 50 6401

## Radiated Emission

Test place            No.3 Semi Anechoic Chamber  
 Date                    Fenruary 27, 2013                    February 28, 2013                    March 1, 2013  
 Temperature / Humidity 23 deg.C, 51 %RH                    22 deg.C, 52 %RH                    22 deg.C, 38 %RH  
 Engineer                Wataru Kojima                        Makoto Hosaka                        Wataru Kojima  
 Mode                    Tx,                    2480 MHz  
                               Tx, Bluetooth, EDR, PRBS9                    Antenna: NIKYYYY00019

(\* PK: Peak, AV: Average, QP: Quasi-Peak)

Polarity	Frequency [MHz]	Detector	Reading [dBuV]	Ant.Fac. [dB/m]	Loss [dB]	Gain [dB]	Result [dBuV/m]	Limit [dBuV/m]	Margin [dB]	Height [cm]	Angle [deg]	Remark
Hori.	130.000	QP	28.0	13.7	7.4	32.1	17.0	43.5	26.5	181	33	
Hori.	182.000	QP	31.7	15.8	7.7	32.1	23.1	43.5	20.4	179	166	
Hori.	2483.500	PK	50.3	27.5	14.3	41.4	50.7	73.9	23.2	100	16	
Hori.	2493.400	PK	46.8	27.6	14.3	41.4	47.3	73.9	26.6	100	16	
Hori.	2520.000	PK	53.0	27.6	14.3	41.4	53.5	73.9	20.4	134	14	
Hori.	4960.000	PK	53.3	31.6	6.9	41.0	50.8	73.9	23.1	100	225	
Hori.	7440.000	PK	55.9	36.7	8.5	41.5	59.6	73.9	14.3	100	328	
Hori.	9920.000	PK	48.0	39.0	9.7	38.9	57.8	73.9	16.1	100	59	
Hori.	12400.000	PK	44.9	39.5	10.8	39.3	55.9	73.9	18.0	100	0	
Hori.	2493.400	AV	34.5	27.6	14.3	41.4	35.0	53.9	18.9	100	16	VBW: 10Hz
Hori.	2520.000	AV	42.5	27.6	14.3	41.4	43.0	53.9	10.9	134	14	VBW: 10Hz
Vert.	130.000	QP	31.6	13.7	7.4	32.1	20.6	43.5	22.9	100	167	
Vert.	182.000	QP	31.6	15.8	7.7	32.1	23.0	43.5	20.5	100	197	
Vert.	2483.500	PK	51.5	27.5	14.3	41.4	51.9	73.9	22.0	100	158	
Vert.	2493.400	PK	52.0	27.6	14.3	41.4	52.5	73.9	21.4	100	158	
Vert.	2520.000	PK	53.8	27.6	14.3	41.4	54.3	73.9	19.6	111	161	
Vert.	4960.000	PK	50.5	31.6	6.9	41.0	48.0	73.9	25.9	100	49	
Vert.	7440.000	PK	54.3	36.7	8.5	41.5	58.0	73.9	15.9	100	17	
Vert.	9920.000	PK	47.0	39.0	9.7	38.9	56.8	73.9	17.1	110	352	
Vert.	12400.000	PK	44.0	39.5	10.8	39.3	55.0	73.9	18.9	100	0	
Vert.	2493.400	AV	36.5	27.6	14.3	41.4	37.0	53.9	16.9	100	158	VBW: 10Hz
Vert.	2520.000	AV	43.0	27.6	14.3	41.4	43.5	53.9	<b>10.4</b>	111	161	VBW: 10Hz

Result = Reading + Ant.Fac. + Loss (Cable+Attenuator+Filter-Distance factor(above 15GHz)) - Gain(Amplifier)

Distance factor : 15GHz -40GHz : 20log(3.0m/1.0m)= 9.5dB

\*Other frequency noises omitted in this report were not seen or have enough margin (more than 20dB).

**Dwell time factor relaxatio**

Polarity	Frequency [MHz]	Detector	Reading [dBuV]	Ant.Fac. [dB/m]	Loss [dB]	Gain [dB]	Dwell Factor [dB]	Result [dBuV/m]	Limit [dBuV/m]	Margin [dB]	Remark
Hori.	2483.500	AV	35.3	27.5	14.3	41.4	-24.8	10.9	53.9	43.0	VBW: 10Hz
Hori.	4960.000	AV	44.9	31.6	6.9	41.0	-24.8	17.6	53.9	36.3	VBW: 10Hz
Hori.	7440.000	AV	46.3	36.7	8.5	41.5	-24.8	25.2	53.9	<b>28.7</b>	VBW: 10Hz
Hori.	9920.000	AV	37.0	39.0	9.7	38.9	-24.8	22.0	53.9	31.9	VBW: 10Hz
Hori.	12400.000	AV	32.9	39.5	10.8	39.3	-24.8	19.1	53.9	34.8	VBW: 10Hz
Vert.	2483.500	AV	36.3	27.5	14.3	41.4	-24.8	11.9	53.9	42.0	VBW: 10Hz
Vert.	4960.000	AV	41.6	31.6	6.9	41.0	-24.8	14.3	53.9	39.6	VBW: 10Hz
Vert.	7440.000	AV	44.8	36.7	8.5	41.5	-24.8	23.7	53.9	30.2	VBW: 10Hz
Vert.	9920.000	AV	36.6	39.0	9.7	38.9	-24.8	21.6	53.9	32.3	VBW: 10Hz
Vert.	12400.000	AV	32.9	39.5	10.8	39.3	-24.8	19.1	53.9	34.8	VBW: 10Hz

Result = Reading + Ant.Fac. + Loss(Cable+Attenuator+Filter-Distance factor(above 15GHz)) - Gain(Amplifier) + Dwell(time)factor

Distance factor : 15GHz -40GHz : 20log(3.0m/1.0m)= 9.5dB

\*Other frequency noises omitted in this report were not seen or have enough margin (more than 20dB).

**UL Japan, Inc.****Shonan EMC Lab.**

1-22-3 Megumigaoka, Hiratsuka-shi, Kanagawa 259-1220 JAPAN

Telephone : +81 463 50 6400

Facsimile : +81 463 50 6401

## Radiated Emission

Test place            No.3 Semi Anechoic Chamber  
Date                    February 26, 2013                    February 27, 2013                    February 28, 2013  
Temperature / Humidity    22 deg.C, 38 %RH                    23 deg.C, 51 %RH                    22 deg.C, 52 %RH  
Engineer               Makoto Hosaka                        Wataru Kojima                        Wataru Kojima  
Mode                    Tx,                    2402 MHz  
                             Tx, Bluetooth, BDR, PRBS9                    Antenna: BT-MAIN-001

(\* PK: Peak, AV: Average, QP: Quasi-Peak)

Polarity	Frequency [MHz]	Detector	Reading [dBuV]	Ant.Fac. [dB/m]	Loss [dB]	Gain [dB]	Result [dBuV/m]	Limit [dBuV/m]	Margin [dB]	Height [cm]	Angle [deg]	Remark
Hori.	130.003	QP	29.4	13.7	7.4	32.1	18.4	43.5	25.1	181	23	
Hori.	182.005	QP	30.0	15.8	7.7	32.1	21.4	43.5	22.1	161	161	
Hori.	2390.000	PK	45.9	27.4	14.2	41.4	46.1	73.9	27.8	100	0	
Hori.	4804.000	PK	48.9	31.1	6.8	41.2	45.6	73.9	28.3	121	320	
Hori.	7206.000	PK	53.4	36.6	8.3	41.4	56.9	73.9	17.0	116	296	
Hori.	9608.000	PK	48.0	38.5	9.5	38.9	57.1	73.9	<b>16.8</b>	126	215	
Hori.	12010.000	PK	45.5	39.4	10.9	39.4	56.4	73.9	17.5	100	0	
Vert.	130.003	QP	31.9	13.7	7.4	32.1	20.9	43.5	22.6	100	155	
Vert.	182.005	QP	32.7	15.8	7.7	32.1	24.1	43.5	19.4	100	353	
Vert.	2390.000	PK	46.3	27.4	14.2	41.4	46.5	73.9	27.4	158	0	
Vert.	4804.000	PK	48.7	31.1	6.8	41.2	45.4	73.9	28.5	100	324	
Vert.	7206.000	PK	53.5	36.6	8.3	41.4	57.0	73.9	16.9	150	320	
Vert.	9608.000	PK	47.7	38.5	9.5	38.9	56.8	73.9	17.1	109	104	
Vert.	12010.000	PK	45.6	39.4	10.9	39.4	56.5	73.9	17.4	100	0	

Result = Reading + Ant.Fac. + Loss (Cable+Attenuator+Filter-Distance factor(above 15GHz)) - Gain(Amplifier)

Distance factor : 15GHz -40GHz :  $20\log(3.0\text{m}/1.0\text{m}) = 9.5\text{dB}$ 

\*Other frequency noises omitted in this report were not seen or have enough margin (more than 20dB).

**Dwell time factor relaxation**

Polarity	Frequency [MHz]	Detector	Reading [dBuV]	Ant.Fac. [dB/m]	Loss [dB]	Gain [dB]	Dwell Factor [dB]	Result [dBuV/m]	Limit [dBuV/m]	Margin [dB]	Remark
Hori.	2390.000	AV	34.0	27.4	14.2	41.4	-24.8	9.4	53.9	44.5	VBW: 10Hz
Hori.	4804.000	AV	40.3	31.1	6.8	41.2	-24.8	12.2	53.9	41.7	VBW: 10Hz
Hori.	7206.000	AV	45.4	36.6	8.3	41.4	-24.8	24.1	53.9	29.8	VBW: 10Hz
Hori.	9608.000	AV	37.0	38.5	9.5	38.9	-24.8	21.3	53.9	32.6	VBW: 10Hz
Hori.	12010.000	AV	33.1	39.4	10.9	39.4	-24.8	19.2	53.9	34.7	VBW: 10Hz
Vert.	2390.000	AV	34.0	27.4	14.2	41.4	-24.8	9.4	53.9	44.5	VBW: 10Hz
Vert.	4804.000	AV	39.8	31.1	6.8	41.2	-24.8	11.7	53.9	42.2	VBW: 10Hz
Vert.	7206.000	AV	45.6	36.6	8.3	41.4	-24.8	24.3	53.9	<b>29.6</b>	VBW: 10Hz
Vert.	9608.000	AV	36.3	38.5	9.5	38.9	-24.8	20.6	53.9	33.3	VBW: 10Hz
Vert.	12010.000	AV	33.0	39.4	10.9	39.4	-24.8	19.1	53.9	34.8	VBW: 10Hz

Result = Reading + Ant.Fac. + Loss(Cable+Attenuator+Filter-Distance factor(above 15GHz)) - Gain(Amplifier) + Dwell(time)factor

Distance factor : 15GHz -40GHz :  $20\log(3.0\text{m}/1.0\text{m}) = 9.5\text{dB}$ 

\*Other frequency noises omitted in this report were not seen or have enough margin (more than 20dB).

**20dBc Data Sheet (RBW 100kHz, VBW 300kHz)**

Polarity	Frequency [MHz]	Detector	Reading [dBuV]	Ant.Fac. [dB/m]	Loss [dB]	Gain [dB]	Result [dBuV/m]	Limit [dBuV/m]	Margin [dB]	Remark
Hori.	2402.000	PK	90.7	27.4	14.2	41.4	90.9	-	-	
Hori.	2400.000	PK	38.0	27.4	14.2	41.4	38.2	70.9	32.7	
Vert.	2402.000	PK	91.8	27.4	14.2	41.4	92.0	-	-	
Vert.	2400.000	PK	38.4	27.4	14.2	41.4	38.6	72.0	33.4	

Result = Reading + Ant.Fac. + Loss(Cable+Attenuator+Filter) - Gain(Amplifier)

**UL Japan, Inc.****Shonan EMC Lab.**

1-22-3 Megumigaoka, Hiratsuka-shi, Kanagawa 259-1220 JAPAN

Telephone : +81 463 50 6400

Facsimile : +81 463 50 6401

## Radiated Emission

Test place            No.3 Semi Anechoic Chamber  
 Date                    February 26, 2013            Fenuary 27, 2013            February 28, 2013  
 Temperature / Humidity 22 deg.C, 38 %RH            23 deg.C, 51 %RH            22 deg.C, 52 %RH  
 Engineer               Makoto Hosaka               Wataru Kojima               Wataru Kojima  
 Mode                    Tx,                    2441 MHz  
                              Tx, Bluetooth, BDR, PRBS9                    Antenna: BT-MAIN-001

(\* PK: Peak, AV: Average, QP: Quasi-Peak)

Polarity	Frequency [MHz]	Detector	Reading [dBuV]	Ant.Fac. [dB/m]	Loss [dB]	Gain [dB]	Result [dBuV/m]	Limit [dBuV/m]	Margin [dB]	Height [cm]	Angle [deg]	Remark
Hori.	130.003	QP	28.0	13.7	7.4	32.1	17.0	43.5	26.5	175	18	
Hori.	182.004	QP	30.0	15.8	7.7	32.1	21.4	43.5	22.1	175	155	
Hori.	4882.000	PK	53.0	31.3	6.9	41.1	50.1	73.9	23.8	100	321	
Hori.	7323.000	PK	54.5	36.6	8.4	41.4	58.1	73.9	<b>15.8</b>	100	324	
Hori.	9764.000	PK	46.7	38.7	9.5	38.9	56.0	73.9	17.9	100	207	
Hori.	12205.000	PK	45.1	39.5	10.9	39.3	56.2	73.9	17.7	100	0	
Vert.	130.003	QP	32.0	13.7	7.4	32.1	21.0	43.5	22.5	100	23	
Vert.	182.004	QP	32.3	15.8	7.7	32.1	23.7	43.5	19.8	100	149	
Vert.	4882.000	PK	52.8	31.3	6.9	41.1	49.9	73.9	24.0	100	21	
Vert.	7323.000	PK	53.6	36.6	8.4	41.4	57.2	73.9	16.7	151	318	
Vert.	9764.000	PK	45.1	38.7	9.5	38.9	54.4	73.9	19.5	100	66	
Vert.	12205.000	PK	45.0	39.5	10.9	39.3	56.1	73.9	17.8	100	0	

Result = Reading + Ant.Fac. + Loss (Cable+Attenuator+Filter-Distance factor(above 15GHz)) - Gain(Amplifier)

Distance factor : 15GHz -40GHz : 20log(3.0m/1.0m)= 9.5dB

\*Other frequency noises omitted in this report were not seen or have enough margin (more than 20dB).

**Dwell time factor relaxatio**

Polarity	Frequency [MHz]	Detector	Reading [dBuV]	Ant.Fac. [dB/m]	Loss [dB]	Gain [dB]	Dwell Factor [dB]	Result [dBuV/m]	Limit [dBuV/m]	Margin [dB]	Remark
Hori.	4882.000	AV	47.1	31.3	6.9	41.1	-24.8	19.4	53.9	34.5	VBW: 10Hz
Hori.	7323.000	AV	46.8	36.6	8.4	41.4	-24.8	25.6	53.9	<b>28.3</b>	VBW: 10Hz
Hori.	9764.000	AV	35.1	38.7	9.5	38.9	-24.8	19.6	53.9	34.3	VBW: 10Hz
Hori.	12205.000	AV	32.4	39.5	10.9	39.3	-24.8	18.7	53.9	35.2	VBW: 10Hz
Vert.	4882.000	AV	46.6	31.3	6.9	41.1	-24.8	18.9	53.9	35.0	VBW: 10Hz
Vert.	7323.000	AV	46.2	36.6	8.4	41.4	-24.8	25.0	53.9	28.9	VBW: 10Hz
Vert.	9764.000	AV	33.6	38.7	9.5	38.9	-24.8	18.1	53.9	35.8	VBW: 10Hz
Vert.	12205.000	AV	32.4	39.5	10.9	39.3	-24.8	18.7	53.9	35.2	VBW: 10Hz

Result = Reading + Ant.Fac. + Loss(Cable+Attenuator+Filter-Distance factor(above 15GHz)) - Gain(Amplifier) + Dwell(time)factor

Distance factor : 15GHz -40GHz : 20log(3.0m/1.0m)= 9.5dB

\*Other frequency noises omitted in this report were not seen or have enough margin (more than 20dB).

**UL Japan, Inc.****Shonan EMC Lab.**

1-22-3 Megumigaoka, Hiratsuka-shi, Kanagawa 259-1220 JAPAN

Telephone : +81 463 50 6400

Facsimile : +81 463 50 6401

## Radiated Emission

Test place            No.3 Semi Anechoic Chamber  
 Date                    Fenruary 27, 2013            Fenruary 27, 2013            February 28, 2013  
 Temperature / Humidity 23 deg.C, 51 %RH            23 deg.C, 51 %RH            22 deg.C, 52 %RH  
 Engineer               Makoto Hosaka                Wataru Kojima                Wataru Kojima  
 Mode                    Tx,                                2480 MHz  
                              Tx, Bluetooth, BDR, PRBS9            Antenna: BT-MAIN-001

(\* PK: Peak, AV: Average, QP: Quasi-Peak)

Polarity	Frequency [MHz]	Detector	Reading [dBuV]	Ant.Fac. [dB/m]	Loss [dB]	Gain [dB]	Result [dBuV/m]	Limit [dBuV/m]	Margin [dB]	Height [cm]	Angle [deg]	Remark
Hori.	130.002	QP	28.8	13.7	7.4	32.1	17.8	43.5	25.7	200	179	
Hori.	182.004	QP	32.6	15.8	7.7	32.1	24.0	43.5	19.5	150	160	
Hori.	2483.500	PK	47.2	27.5	14.3	41.4	47.6	73.9	26.3	100	0	
Hori.	4960.000	PK	53.7	31.6	6.9	41.0	51.2	73.9	22.7	100	325	
Hori.	7440.000	PK	53.1	36.7	8.5	41.5	56.8	73.9	17.1	126	302	
Hori.	9920.000	PK	47.6	39.0	9.7	38.9	57.4	73.9	16.5	136	114	
Hori.	12400.000	PK	44.9	39.5	10.8	39.3	55.9	73.9	18.0	100	0	
Vert.	130.002	QP	32.2	13.7	7.4	32.1	21.2	43.5	22.3	100	238	
Vert.	182.004	QP	33.8	15.8	7.7	32.1	25.2	43.5	18.3	100	2	
Vert.	2483.500	PK	47.4	27.5	14.3	41.4	47.8	73.9	26.1	100	170	
Vert.	4960.000	PK	52.2	31.6	6.9	41.0	49.7	73.9	24.2	100	24	
Vert.	7440.000	PK	54.0	36.7	8.5	41.5	57.7	73.9	16.2	130	321	
Vert.	9920.000	PK	45.1	39.0	9.7	38.9	54.9	73.9	19.0	100	125	
Vert.	12400.000	PK	44.7	39.5	10.8	39.3	55.7	73.9	18.2	100	0	

Result = Reading + Ant.Fac. + Loss (Cable+Attenuator+Filter-Distance factor(above 15GHz)) - Gain(Amplifier)

Distance factor : 15GHz -40GHz : 20log(3.0m/1.0m)= 9.5dB

\*Other frequency noises omitted in this report were not seen or have enough margin (more than 20dB).

**Dwell time factor relaxatio**

Polarity	Frequency [MHz]	Detector	Reading [dBuV]	Ant.Fac. [dB/m]	Loss [dB]	Gain [dB]	Dwell Factor [dB]	Result [dBuV/m]	Limit [dBuV/m]	Margin [dB]	Remark
Hori.	2483.500	AV	34.1	27.5	14.3	41.4	-24.8	9.7	53.9	44.2	VBW: 10Hz
Hori.	4960.000	AV	47.9	31.6	6.9	41.0	-24.8	20.6	53.9	33.3	VBW: 10Hz
Hori.	7440.000	AV	45.3	36.7	8.5	41.5	-24.8	24.2	53.9	29.7	VBW: 10Hz
Hori.	9920.000	AV	35.9	39.0	9.7	38.9	-24.8	20.9	53.9	33.0	VBW: 10Hz
Hori.	12400.000	AV	32.5	39.5	10.8	39.3	-24.8	18.7	53.9	35.2	VBW: 10Hz
Vert.	2483.500	AV	34.4	27.5	14.3	41.4	-24.8	10.0	53.9	43.9	VBW: 10Hz
Vert.	4960.000	AV	45.4	31.6	6.9	41.0	-24.8	18.1	53.9	35.8	VBW: 10Hz
Vert.	7440.000	AV	46.4	36.7	8.5	41.5	-24.8	25.3	53.9	28.6	VBW: 10Hz
Vert.	9920.000	AV	33.7	39.0	9.7	38.9	-24.8	18.7	53.9	35.2	VBW: 10Hz
Vert.	12400.000	AV	32.5	39.5	10.8	39.3	-24.8	18.7	53.9	35.2	VBW: 10Hz

Result = Reading + Ant.Fac. + Loss(Cable+Attenuator+Filter-Distance factor(above 15GHz)) - Gain(Amplifier) + Dwell(time)factor

Distance factor : 15GHz -40GHz : 20log(3.0m/1.0m)= 9.5dB

\*Other frequency noises omitted in this report were not seen or have enough margin (more than 20dB).

**UL Japan, Inc.****Shonan EMC Lab.**

1-22-3 Megumigaoka, Hiratsuka-shi, Kanagawa 259-1220 JAPAN

Telephone : +81 463 50 6400

Facsimile : +81 463 50 6401

## Radiated Emission

Test place            No.3 Semi Anechoic Chamber  
 Date                    Fenruary 27, 2013            Fenruary 27, 2013            February 28, 2013  
 Temperature / Humidity 23 deg.C, 51 %RH            23 deg.C, 51 %RH            22 deg.C, 52 %RH  
 Engineer               Makoto Hosaka                Wataru Kojima                Wataru Kojima  
 Mode                    Tx,                                2402 MHz  
                               Tx, Bluetooth, EDR, PRBS9            Antenna: BT-MAIN-001

(\* PK: Peak, AV: Average, QP: Quasi-Peak)

Polarity	Frequency [MHz]	Detector	Reading [dBuV]	Ant.Fac. [dB/m]	Loss [dB]	Gain [dB]	Result [dBuV/m]	Limit [dBuV/m]	Margin [dB]	Height [cm]	Angle [deg]	Remark
Hori.	130.000	QP	28.2	13.7	7.4	32.1	17.2	43.5	26.3	200	22	
Hori.	182.010	QP	31.2	15.8	7.7	32.1	22.6	43.5	20.9	174	187	
Hori.	2362.200	PK	49.7	27.4	14.1	41.4	49.8	73.9	24.1	100	3	
Hori.	2384.430	PK	51.4	27.4	14.2	41.4	51.6	73.9	22.3	100	3	
Hori.	2390.000	PK	46.3	27.4	14.2	41.4	46.5	73.9	27.4	100	3	
Hori.	4804.000	PK	57.8	31.1	6.8	41.2	54.5	73.9	19.4	100	317	
Hori.	7206.000	PK	53.5	36.6	8.3	41.4	57.0	73.9	16.9	118	324	
Hori.	9608.000	PK	51.0	38.5	9.5	38.9	60.1	73.9	<b>13.8</b>	100	209	
Hori.	12010.000	PK	44.9	39.4	10.9	39.4	55.8	73.9	18.1	100	0	
Hori.	2362.200	AV	36.5	27.4	14.1	41.4	36.6	53.9	17.3	100	3	VBW: 10Hz
Hori.	2384.430	AV	34.1	27.4	14.2	41.4	34.3	53.9	19.6	100	3	VBW: 10Hz
Vert.	130.003	QP	31.9	13.7	7.4	32.1	20.9	43.5	22.6	100	169	
Vert.	182.004	QP	32.6	15.8	7.7	32.1	24.0	43.5	19.5	100	12	
Vert.	2362.200	PK	49.8	27.4	14.1	41.4	49.9	73.9	24.0	115	148	
Vert.	2384.615	PK	52.0	27.4	14.2	41.4	52.2	73.9	21.7	115	148	
Vert.	2390.000	PK	46.1	27.4	14.2	41.4	46.3	73.9	27.6	115	148	
Vert.	4804.000	PK	57.9	31.1	6.8	41.2	54.6	73.9	19.3	117	20	
Vert.	7206.000	PK	50.1	36.6	8.3	41.4	53.6	73.9	20.3	100	12	
Vert.	9608.000	PK	50.0	38.5	9.5	38.9	59.1	73.9	14.8	100	108	
Vert.	12010.000	PK	44.6	39.4	10.9	39.4	55.5	73.9	18.4	100	0	
Vert.	2362.200	AV	37.7	27.4	14.1	41.4	37.8	53.9	16.1	115	148	VBW: 10Hz
Vert.	2384.615	AV	34.1	27.4	14.2	41.4	34.3	53.9	19.6	115	148	VBW: 10Hz

Result = Reading + Ant.Fac. + Loss (Cable+Attenuator+Filter-Distance factor(above 15GHz)) - Gain(Amplifier)

Distance factor : 15GHz -40GHz : 20log(3.0m/1.0m)= 9.5dB

\*Other frequency noises omitted in this report were not seen or have enough margin (more than 20dB).

**Dwell time factor relaxatio**

Polarity	Frequency [MHz]	Detector	Reading [dBuV]	Ant.Fac. [dB/m]	Loss [dB]	Gain [dB]	Dwell Factor [dB]	Result [dBuV/m]	Limit [dBuV/m]	Margin [dB]	Remark
Hori.	2390.000	AV	34.1	27.4	14.2	41.4	-24.8	9.5	53.9	44.4	VBW: 10Hz
Hori.	4804.000	AV	49.7	31.1	6.8	41.2	-24.8	21.6	53.9	32.3	VBW: 10Hz
Hori.	7206.000	AV	43.8	36.6	8.3	41.4	-24.8	22.5	53.9	31.4	VBW: 10Hz
Hori.	9608.000	AV	40.9	38.5	9.5	38.9	-24.8	25.2	53.9	<b>28.7</b>	VBW: 10Hz
Hori.	12010.000	AV	32.8	39.4	10.9	39.4	-24.8	18.9	53.9	35.0	VBW: 10Hz
Vert.	2390.000	AV	34.2	27.4	14.2	41.4	-24.8	9.6	53.9	44.3	VBW: 10Hz
Vert.	4804.000	AV	50.0	31.1	6.8	41.2	-24.8	21.9	53.9	32.0	VBW: 10Hz
Vert.	7206.000	AV	40.1	36.6	8.3	41.4	-24.8	18.8	53.9	35.1	VBW: 10Hz
Vert.	9608.000	AV	39.4	38.5	9.5	38.9	-24.8	23.7	53.9	30.2	VBW: 10Hz
Vert.	12010.000	AV	32.7	39.4	10.9	39.4	-24.8	18.8	53.9	35.1	VBW: 10Hz

Result = Reading + Ant.Fac. + Loss(Cable+Attenuator+Filter-Distance factor(above 15GHz)) - Gain(Amplifier) + Dwell(time)factor

Distance factor : 15GHz -40GHz : 20log(3.0m/1.0m)= 9.5dB

\*Other frequency noises omitted in this report were not seen or have enough margin (more than 20dB).

**20dBc Data Sheet (RBW 100kHz, VBW 300kHz)**

Polarity	Frequency [MHz]	Detector	Reading [dBuV]	Ant.Fac. [dB/m]	Loss [dB]	Gain [dB]	Result [dBuV/m]	Limit [dBuV/m]	Margin [dB]	Remark
Hori.	2402.000	PK	90.1	27.4	14.2	41.4	90.3	-	-	
Hori.	2400.000	PK	44.2	27.4	14.2	41.4	44.4	70.3	25.9	
Vert.	2402.000	PK	92.3	27.4	14.2	41.4	92.5	-	-	
Vert.	2400.000	PK	45.7	27.4	14.2	41.4	45.9	72.5	26.6	

Result = Reading + Ant.Fac. + Loss(Cable+Attenuator+Filter) - Gain(Amplifier)

**UL Japan, Inc.****Shonan EMC Lab.**

1-22-3 Megumigaoka, Hiratsuka-shi, Kanagawa 259-1220 JAPAN

Telephone : +81 463 50 6400

Facsimile : +81 463 50 6401

## Radiated Emission

Test place            No.3 Semi Anechoic Chamber  
Date                    Fenruary 27, 2013                    Fenruary 27, 2013                    February 28, 2013  
Temperature / Humidity 23 deg.C, 51 %RH                    23 deg.C, 51 %RH                    22 deg.C, 52 %RH  
Engineer              Makoto Hosaka                        Wataru Kojima                        Wataru Kojima  
Mode                    Tx,                    2441 MHz  
                            Tx, Bluetooth, EDR, PRBS9                    Antenna: BT-MAIN-001

(\* PK: Peak, AV: Average, QP: Quasi-Peak)

Polarity	Frequency [MHz]	Detector	Reading [dBuV]	Ant.Fac. [dB/m]	Loss [dB]	Gain [dB]	Result [dBuV/m]	Limit [dBuV/m]	Margin [dB]	Height [cm]	Angle [deg]	Remark
Hori.	130.000	QP	29.6	13.7	7.4	32.1	18.6	43.5	24.9	150	34	
Hori.	182.008	QP	31.0	15.8	7.7	32.1	22.4	43.5	21.1	200	188	
Hori.	4882.000	PK	55.8	31.3	6.9	41.1	52.9	73.9	21.0	100	211	
Hori.	7323.000	PK	54.8	36.6	8.4	41.4	58.4	73.9	15.5	100	324	
Hori.	9764.000	PK	51.5	38.7	9.5	38.9	60.8	73.9	<b>13.1</b>	122	212	
Hori.	12205.000	PK	45.1	39.5	10.9	39.3	56.2	73.9	17.7	100	0	
Vert.	130.000	QP	32.2	13.7	7.4	32.1	21.2	43.5	22.3	100	155	
Vert.	182.004	QP	32.5	15.8	7.7	32.1	23.9	43.5	19.6	100	12	
Vert.	4882.000	PK	55.5	31.3	6.9	41.1	52.6	73.9	21.3	105	14	
Vert.	7323.000	PK	54.1	36.6	8.4	41.4	57.7	73.9	16.2	135	311	
Vert.	9764.000	PK	49.4	38.7	9.5	38.9	58.7	73.9	15.2	100	121	
Vert.	12205.000	PK	44.8	39.5	10.9	39.3	55.9	73.9	18.0	100	0	

Result = Reading + Ant.Fac. + Loss (Cable+Attenuator+Filter-Distance factor(above 15GHz)) - Gain(Amplifier)

Distance factor : 15GHz -40GHz : 20log(3.0m/1.0m)= 9.5dB

\*Other frequency noises omitted in this report were not seen or have enough margin (more than 20dB).

**Dwell time factor relaxatio**

Polarity	Frequency [MHz]	Detector	Reading [dBuV]	Ant.Fac. [dB/m]	Loss [dB]	Gain [dB]	Dwell Factor [dB]	Result [dBuV/m]	Limit [dBuV/m]	Margin [dB]	Remark
Hori.	4882.000	AV	47.8	31.3	6.9	41.1	-24.8	20.1	53.9	33.8	VBW: 10Hz
Hori.	7323.000	AV	45.4	36.6	8.4	41.4	-24.8	24.2	53.9	29.7	VBW: 10Hz
Hori.	9764.000	AV	41.3	38.7	9.5	38.9	-24.8	25.9	53.9	<b>28.1</b>	VBW: 10Hz
Hori.	12205.000	AV	32.2	39.5	10.9	39.3	-24.8	18.5	53.9	35.4	VBW: 10Hz
Vert.	4882.000	AV	47.3	31.3	6.9	41.1	-24.8	19.6	53.9	34.3	VBW: 10Hz
Vert.	7323.000	AV	44.0	36.6	8.4	41.4	-24.8	22.8	53.9	31.1	VBW: 10Hz
Vert.	9764.000	AV	38.6	38.7	9.5	38.9	-24.8	23.1	53.9	30.8	VBW: 10Hz
Vert.	12205.000	AV	32.2	39.5	10.9	39.3	-24.8	18.5	53.9	35.4	VBW: 10Hz

Result = Reading + Ant.Fac. + Loss(Cable+Attenuator+Filter-Distance factor(above 15GHz)) - Gain(Amplifier) + Dwell(time)factor

Distance factor : 15GHz -40GHz : 20log(3.0m/1.0m)= 9.5dB

\*Other frequency noises omitted in this report were not seen or have enough margin (more than 20dB).

**UL Japan, Inc.****Shonan EMC Lab.**

1-22-3 Megumigaoka, Hiratsuka-shi, Kanagawa 259-1220 JAPAN

Telephone : +81 463 50 6400

Facsimile : +81 463 50 6401

## Radiated Emission

Test place            No.3 Semi Anechoic Chamber  
Date                    Fenruary 27, 2013                    Fenruary 27, 2013                    February 28, 2013  
Temperature / Humidity    23 deg.C, 51 %RH                    23 deg.C, 51 %RH                    22 deg.C, 52 %RH  
Engineer               Makoto Hosaka                        Wataru Kojima                        Wataru Kojima  
Mode                    Tx,                    2480 MHz  
                              Tx, Bluetooth, EDR, PRBS9                    Antenna: BT-MAIN-001

(\* PK: Peak, AV: Average, QP: Quasi-Peak)

Polarity	Frequency [MHz]	Detector	Reading [dBuV]	Ant.Fac. [dB/m]	Loss [dB]	Gain [dB]	Result [dBuV/m]	Limit [dBuV/m]	Margin [dB]	Height [cm]	Angle [deg]	Remark
Hori.	130.000	QP	28.3	13.7	7.4	32.1	17.3	43.5	26.2	200	25	
Hori.	182.007	QP	29.5	15.8	7.7	32.1	20.9	43.5	22.6	180	171	
Hori.	2483.500	PK	50.0	27.5	14.3	41.4	50.4	73.9	23.5	100	0	
Hori.	2493.400	PK	47.0	27.6	14.3	41.4	47.5	73.9	26.4	100	0	
Hori.	2520.000	PK	51.6	27.6	14.3	41.4	52.1	73.9	21.8	100	0	
Hori.	4960.000	PK	56.3	31.6	6.9	41.0	53.8	73.9	20.1	100	213	
Hori.	7440.000	PK	54.1	36.7	8.5	41.5	57.8	73.9	16.1	100	323	
Hori.	9920.000	PK	51.4	39.0	9.7	38.9	61.2	73.9	12.7	114	205	
Hori.	12400.000	PK	44.8	39.5	10.8	39.3	55.8	73.9	18.1	100	0	
Hori.	2493.400	AV	34.3	27.6	14.3	41.4	34.8	53.9	19.1	100	0	VBW: 10Hz
Hori.	2520.000	AV	38.8	27.6	14.3	41.4	39.3	53.9	14.6	100	0	VBW: 10Hz
Vert.	130.002	QP	31.0	13.7	7.4	32.1	20.0	43.5	23.5	100	359	
Vert.	182.007	QP	31.0	15.8	7.7	32.1	22.4	43.5	21.1	100	3	
Vert.	2483.500	PK	52.1	27.5	14.3	41.4	52.5	73.9	21.4	100	165	
Vert.	2493.400	PK	47.9	27.6	14.3	41.4	48.4	73.9	25.5	100	165	
Vert.	2520.000	PK	54.3	27.6	14.3	41.4	54.8	73.9	19.1	100	165	
Vert.	4960.000	PK	53.2	31.6	6.9	41.0	50.7	73.9	23.2	100	19	
Vert.	7440.000	PK	54.1	36.7	8.5	41.5	57.8	73.9	16.1	147	318	
Vert.	9920.000	PK	48.3	39.0	9.7	38.9	58.1	73.9	15.8	100	102	
Vert.	12400.000	PK	45.2	39.5	10.8	39.3	56.2	73.9	17.7	100	0	
Vert.	2493.400	AV	34.8	27.6	14.3	41.4	35.3	53.9	18.6	100	165	VBW: 10Hz
Vert.	2520.000	AV	42.5	27.6	14.3	41.4	43.0	53.9	<b>10.9</b>	100	165	VBW: 10Hz

Result = Reading + Ant.Fac. + Loss (Cable+Attenuator+Filter-Distance factor(above 15GHz)) - Gain(Amplifier)

Distance factor : 15GHz -40GHz : 20log(3.0m/1.0m)= 9.5dB

\*Other frequency noises omitted in this report were not seen or have enough margin (more than 20dB).

**Dwell time factor relaxatio**

Polarity	Frequency [MHz]	Detector	Reading [dBuV]	Ant.Fac. [dB/m]	Loss [dB]	Gain [dB]	Dwell Factor [dB]	Result [dBuV/m]	Limit [dBuV/m]	Margin [dB]	Remark
Hori.	2483.500	AV	35.2	27.5	14.3	41.4	-24.8	10.8	53.9	43.1	VBW: 10Hz
Hori.	4960.000	AV	48.6	31.6	6.9	41.0	-24.8	21.3	53.9	32.6	VBW: 10Hz
Hori.	7440.000	AV	44.3	36.7	8.5	41.5	-24.8	23.3	53.9	30.7	VBW: 10Hz
Hori.	9920.000	AV	40.8	39.0	9.7	38.9	-24.8	25.8	53.9	<b>28.1</b>	VBW: 10Hz
Hori.	12400.000	AV	32.5	39.5	10.8	39.3	-24.8	18.7	53.9	35.2	VBW: 10Hz
Vert.	2483.500	AV	36.5	27.5	14.3	41.4	-24.8	12.1	53.9	41.8	VBW: 10Hz
Vert.	4960.000	AV	44.5	31.6	6.9	41.0	-24.8	17.2	53.9	36.7	VBW: 10Hz
Vert.	7440.000	AV	44.4	36.7	8.5	41.5	-24.8	23.3	53.9	30.6	VBW: 10Hz
Vert.	9920.000	AV	37.1	39.0	9.7	38.9	-24.8	22.1	53.9	31.8	VBW: 10Hz
Vert.	12400.000	AV	32.5	39.5	10.8	39.3	-24.8	18.7	53.9	35.2	VBW: 10Hz

Result = Reading + Ant.Fac. + Loss(Cable+Attenuator+Filter-Distance factor(above 15GHz)) - Gain(Amplifier) + Dwell(time)factor

Distance factor : 15GHz -40GHz : 20log(3.0m/1.0m)= 9.5dB

\*Other frequency noises omitted in this report were not seen or have enough margin (more than 20dB).

**UL Japan, Inc.****Shonan EMC Lab.**

1-22-3 Megumigaoka, Hiratsuka-shi, Kanagawa 259-1220 JAPAN

Telephone : +81 463 50 6400

Facsimile : +81 463 50 6401

## Dwell time factor Calculation chart

### Dwell time factor Calculation Tx, Bluetooth, BDR, PRBS9

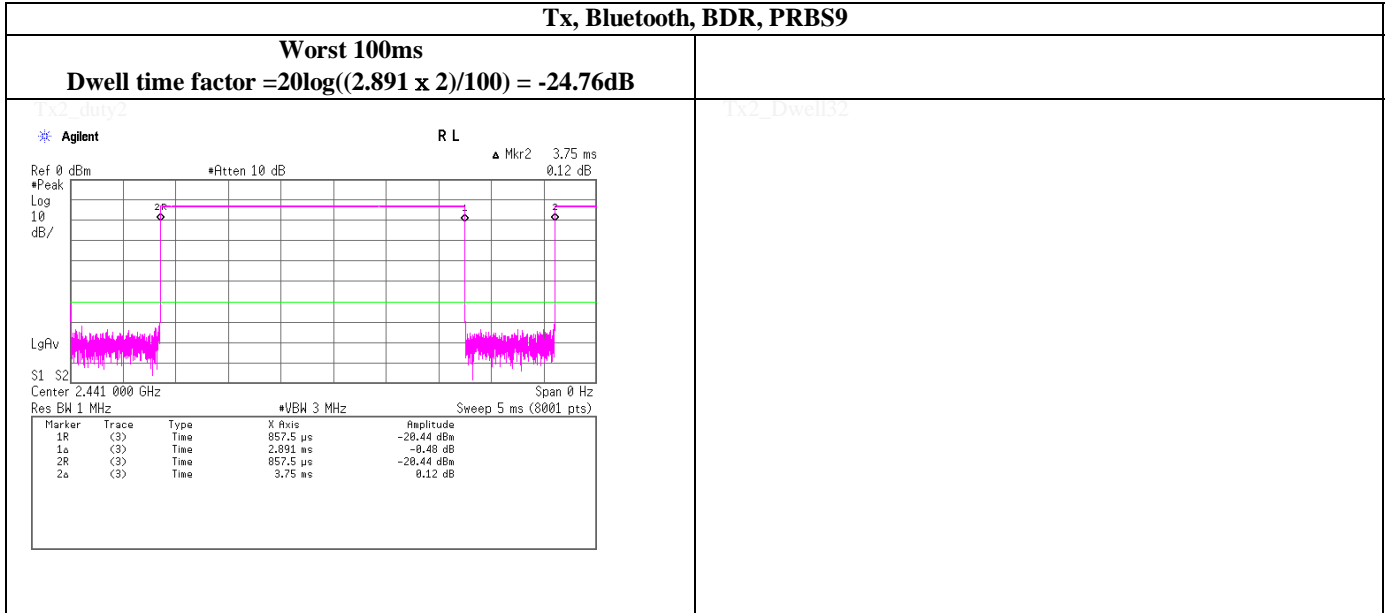

ON time of some channel during 100ms: Twice  
This is the worst case in hopping sequence of Bluetooth.

**UL Japan, Inc.**

**Shonan EMC Lab.**

1-22-3 Megumigaoka, Hiratsuka-shi, Kanagawa 259-1220 JAPAN

Telephone : +81 463 50 6400

Facsimile : +81 463 50 6401

## Dwell time factor Calculation chart

### Dwell time factor Calculation Tx, Bluetooth, EDR, PRBS9

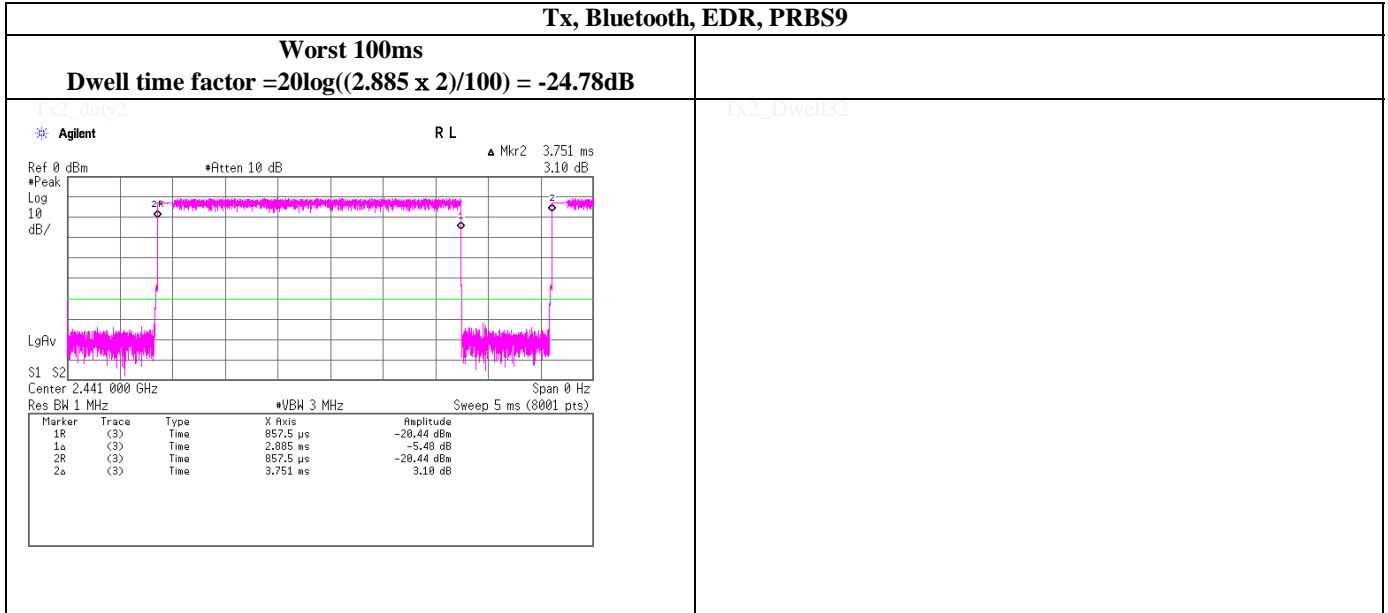

ON time of some channel during 100ms: Twice  
This is the worst case in hopping sequence of Bluetooth.

### Spurious emission (Conducted)

Tx, Bluetooth, BDR, PRBS9

Tx, 2402MHz (below 1GHz)

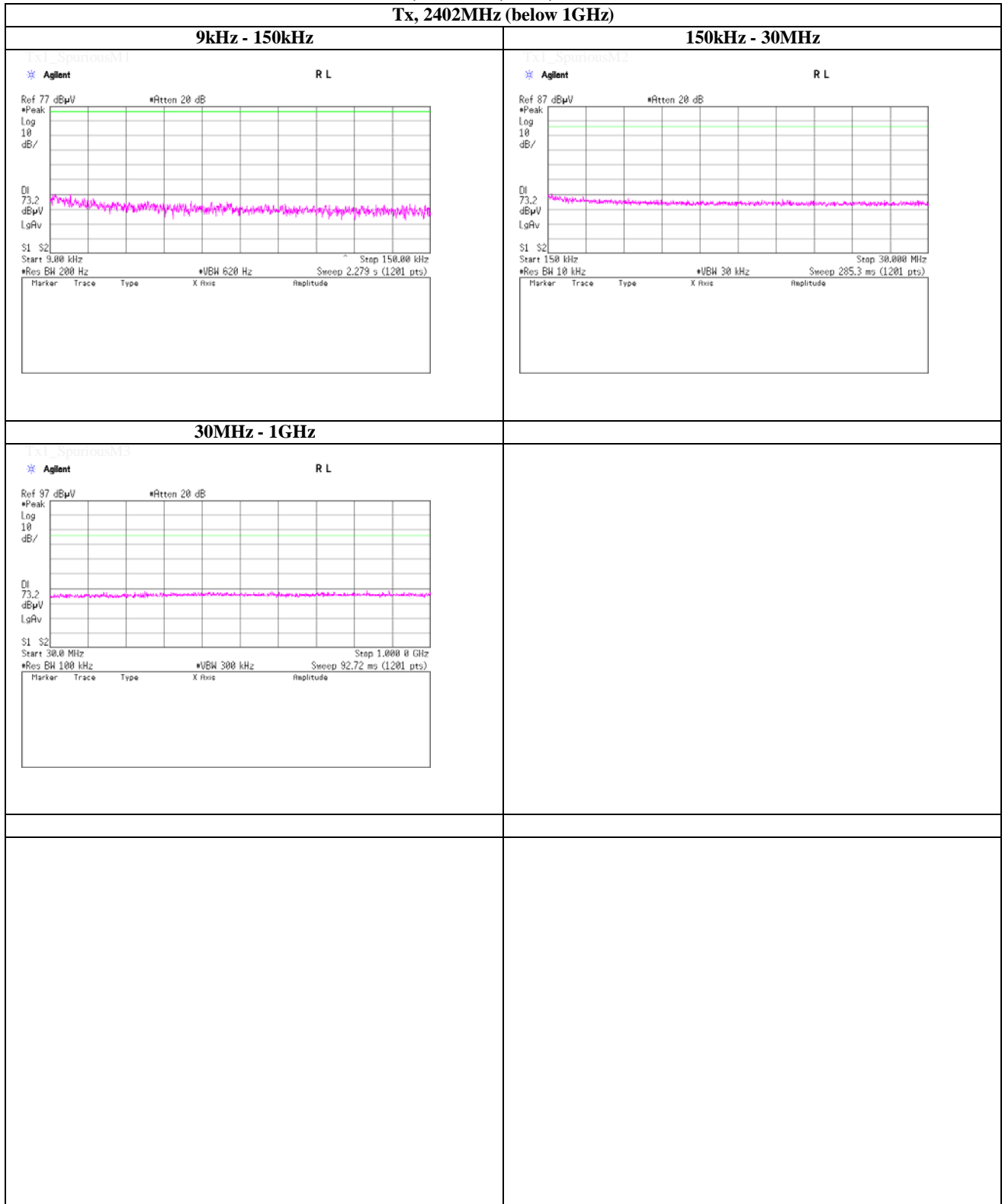

**UL Japan, Inc.**

**Shonan EMC Lab.**

1-22-3 Megumigaoka, Hiratsuka-shi, Kanagawa 259-1220 JAPAN

Telephone : +81 463 50 6400

Facsimile : +81 463 50 6401

## Spurious emission (Conducted)

Tx, Bluetooth, BDR, PRBS9

Tx, 2402MHz (above 1GHz)

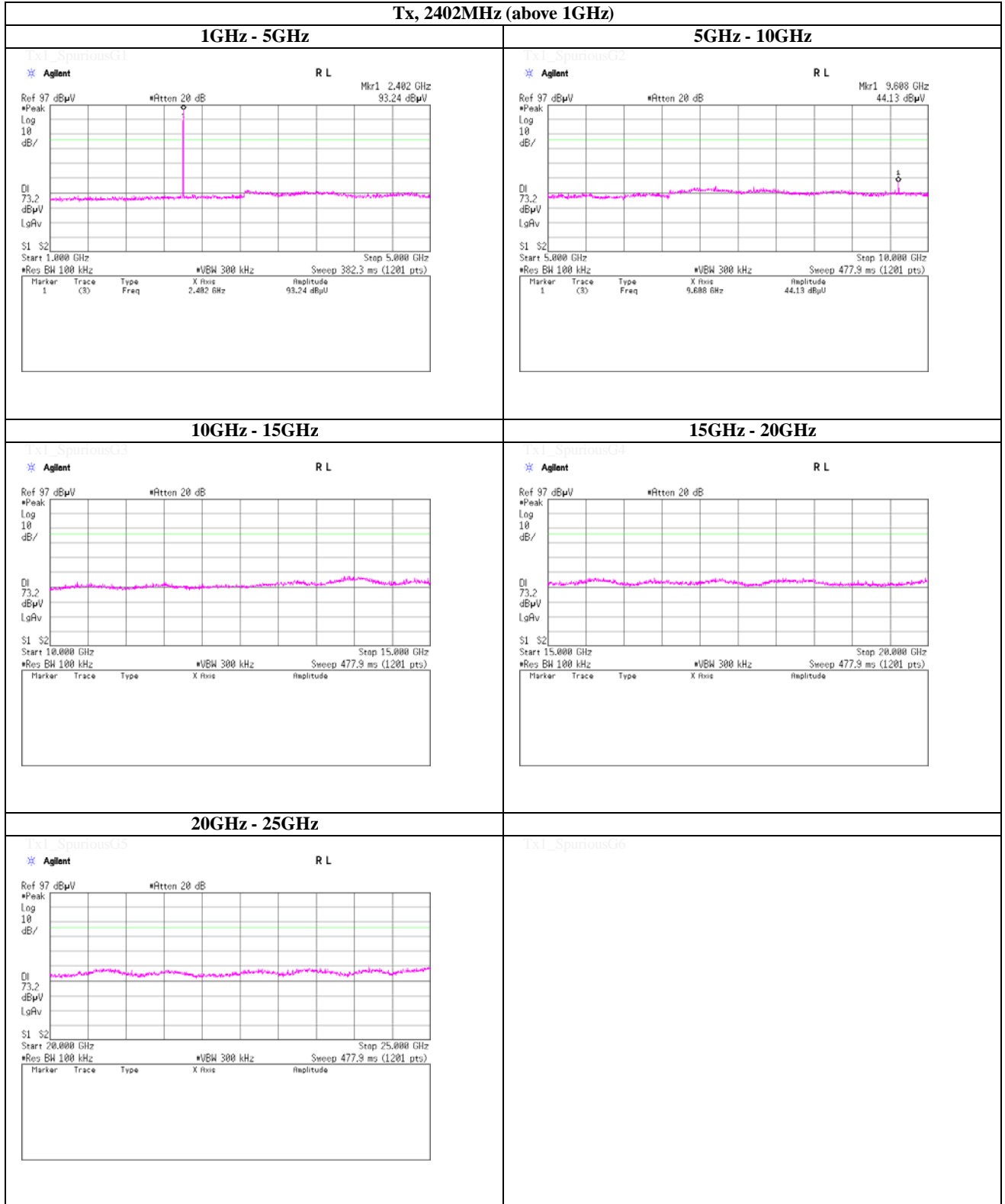

**UL Japan, Inc.**

**Shonan EMC Lab.**

1-22-3 Megumigaoka, Hiratsuka-shi, Kanagawa 259-1220 JAPAN

Telephone : +81 463 50 6400

Facsimile : +81 463 50 6401

## Spurious emission (Conducted)

Tx, Bluetooth, BDR, PRBS9

Tx, 2441MHz (below 1GHz)

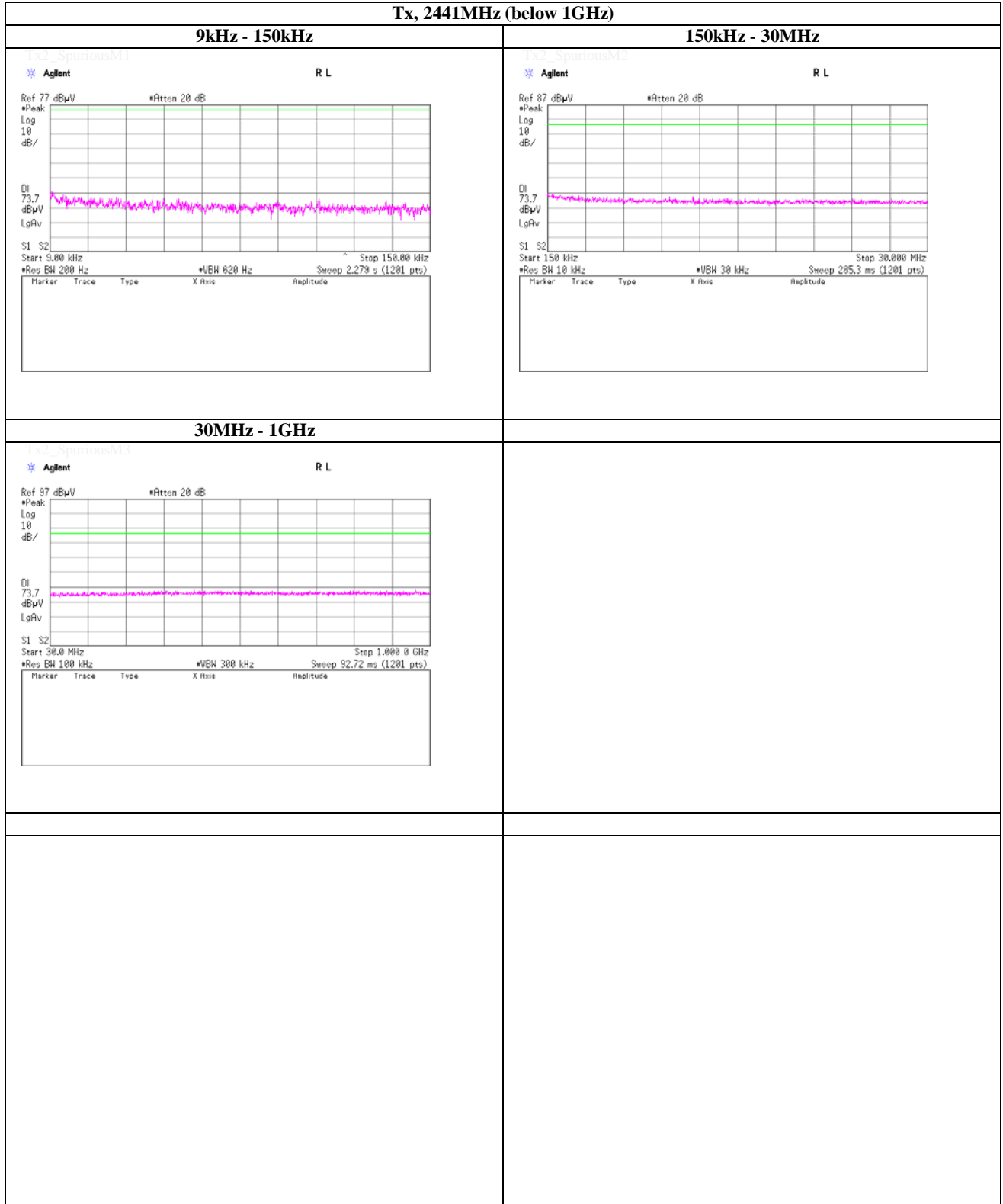

**UL Japan, Inc.**

**Shonan EMC Lab.**

1-22-3 Megumigaoka, Hiratsuka-shi, Kanagawa 259-1220 JAPAN

Telephone : +81 463 50 6400

Facsimile : +81 463 50 6401

## Spurious emission (Conducted)

Tx, Bluetooth, BDR, PRBS9

Tx, 2441MHz (above 1GHz)

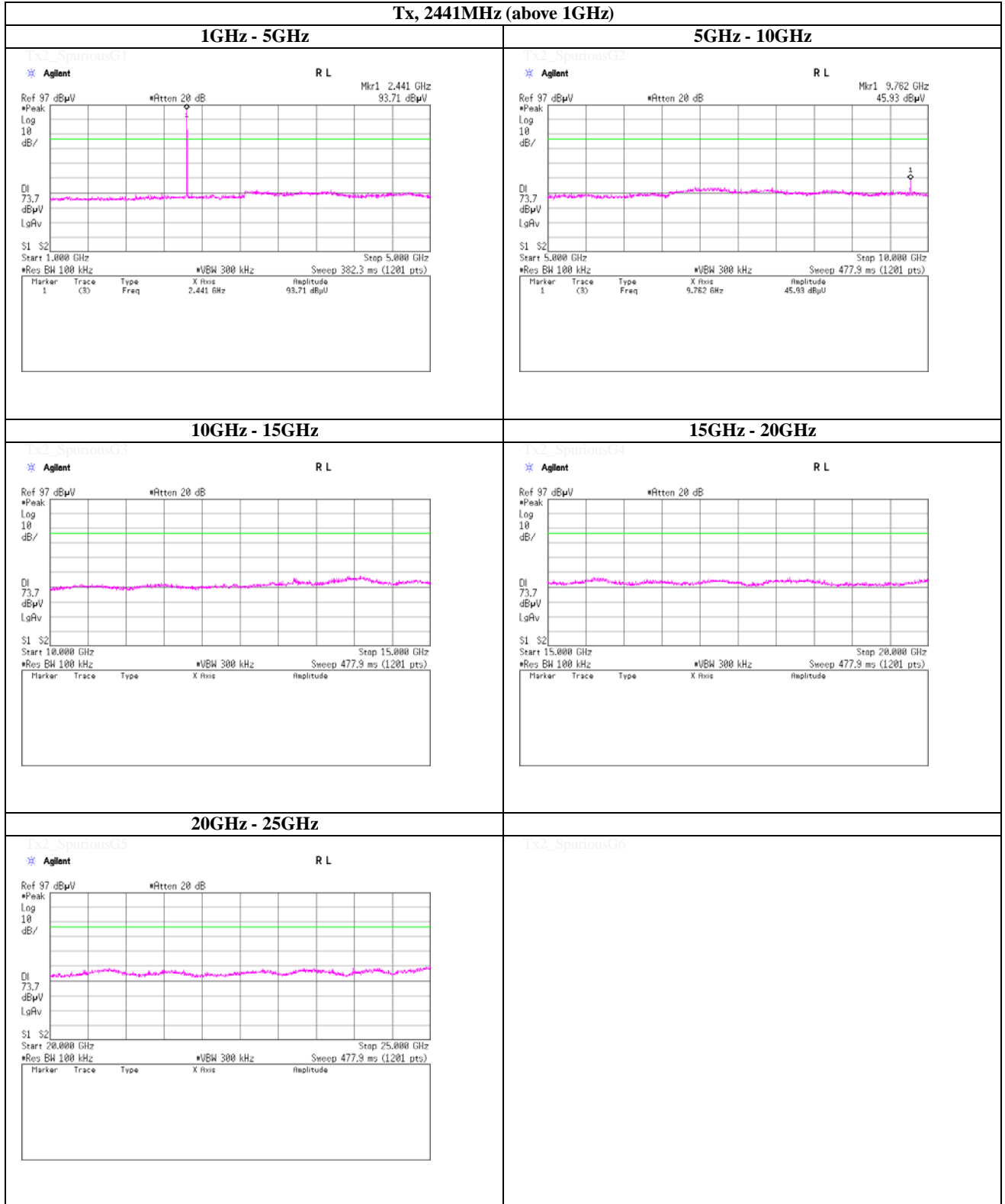

**UL Japan, Inc.**

**Shonan EMC Lab.**

1-22-3 Megumigaoka, Hiratsuka-shi, Kanagawa 259-1220 JAPAN

Telephone : +81 463 50 6400

Facsimile : +81 463 50 6401

**Spurious emission (Conducted)**

**Tx, Bluetooth, BDR, PRBS9**

**Tx, 2480MHz (below 1GHz)**

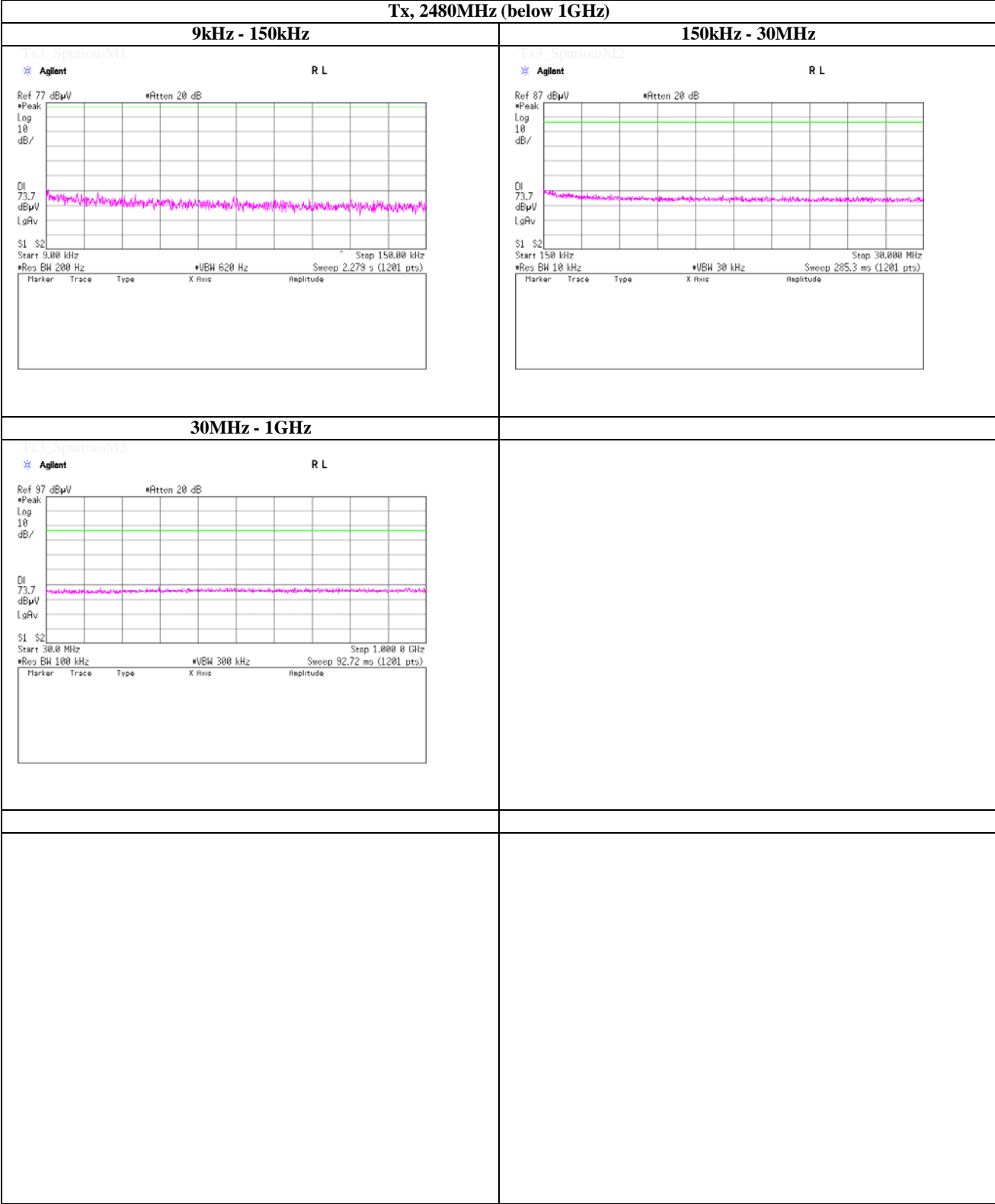

**UL Japan, Inc.**  
**Shonan EMC Lab.**  
1-22-3 Megumigaoka, Hiratsuka-shi, Kanagawa 259-1220 JAPAN  
Telephone : +81 463 50 6400  
Facsimile : +81 463 50 6401

### Spurious emission (Conducted)

Tx, Bluetooth, BDR, PRBS9

Tx, 2480MHz (above 1GHz)

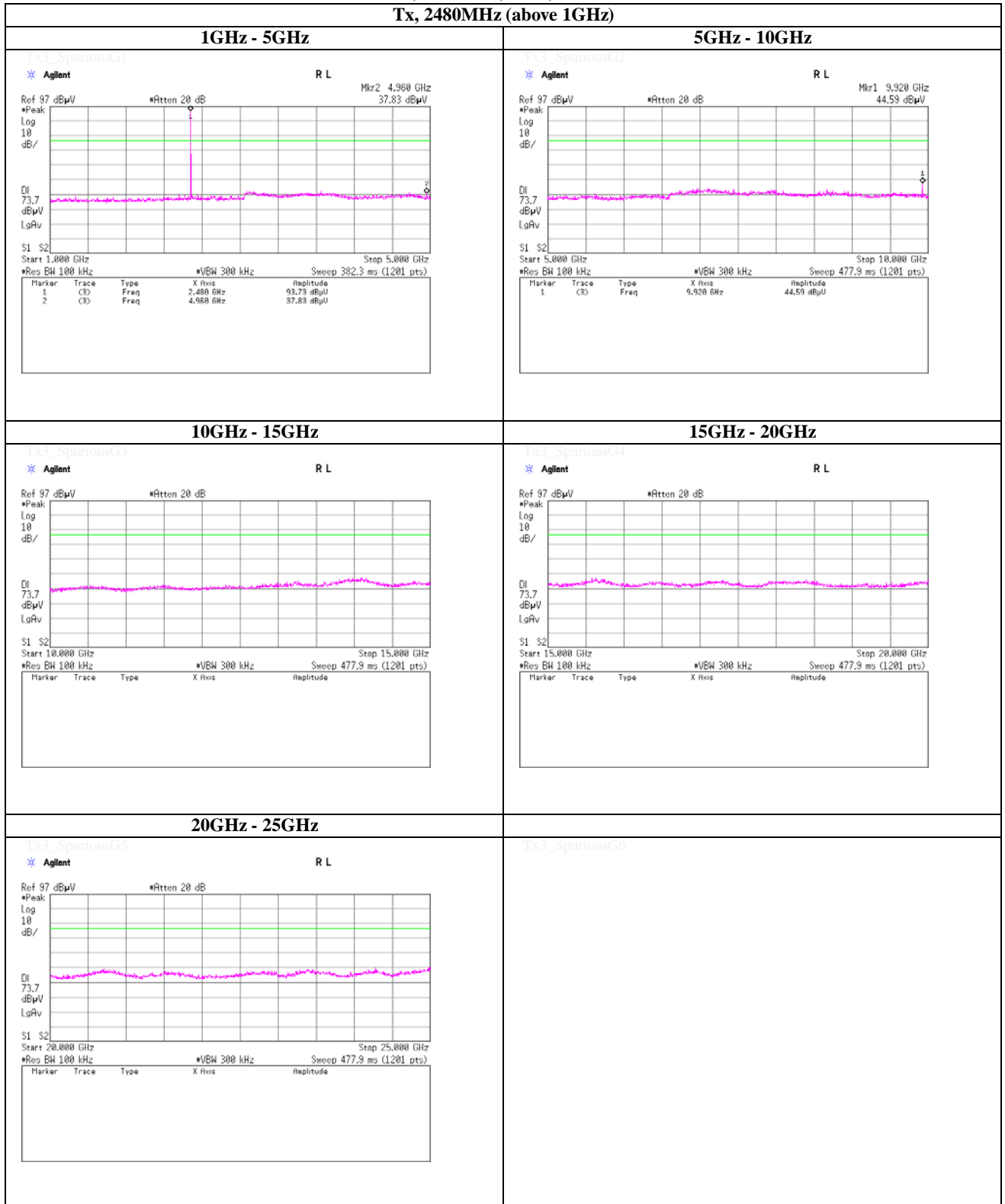

**UL Japan, Inc.**

**Shonan EMC Lab.**

1-22-3 Megumigaoka, Hiratsuka-shi, Kanagawa 259-1220 JAPAN

Telephone : +81 463 50 6400

Facsimile : +81 463 50 6401

## Spurious emission (Conducted)

### Band Edge compliace

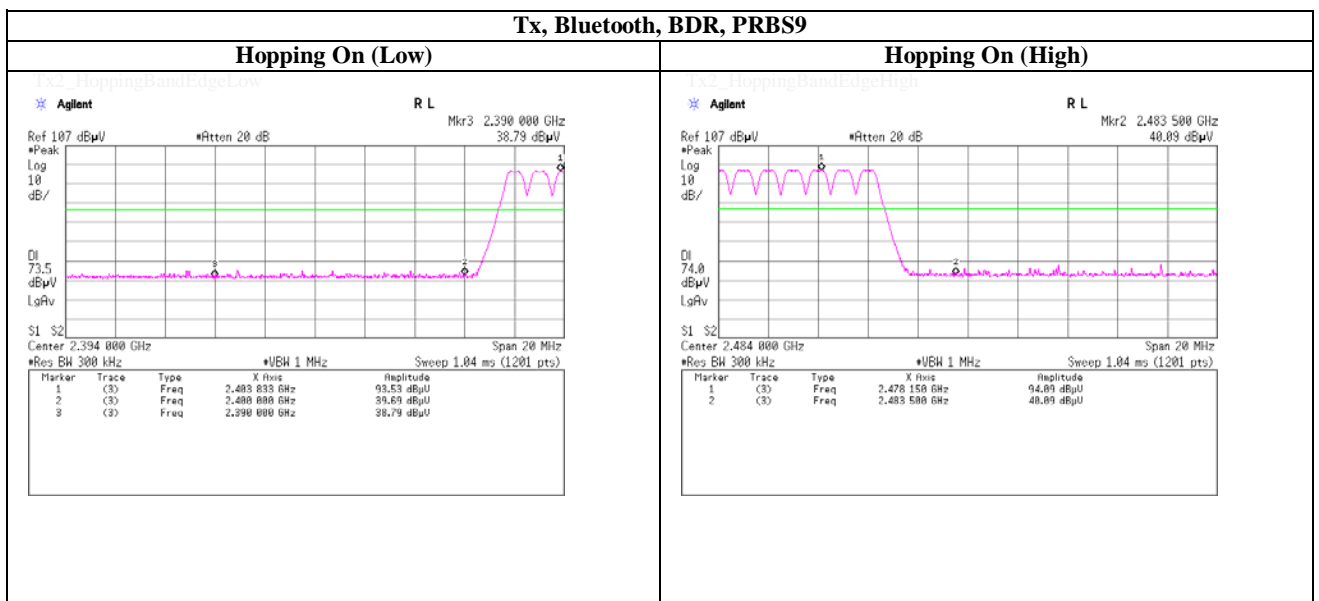
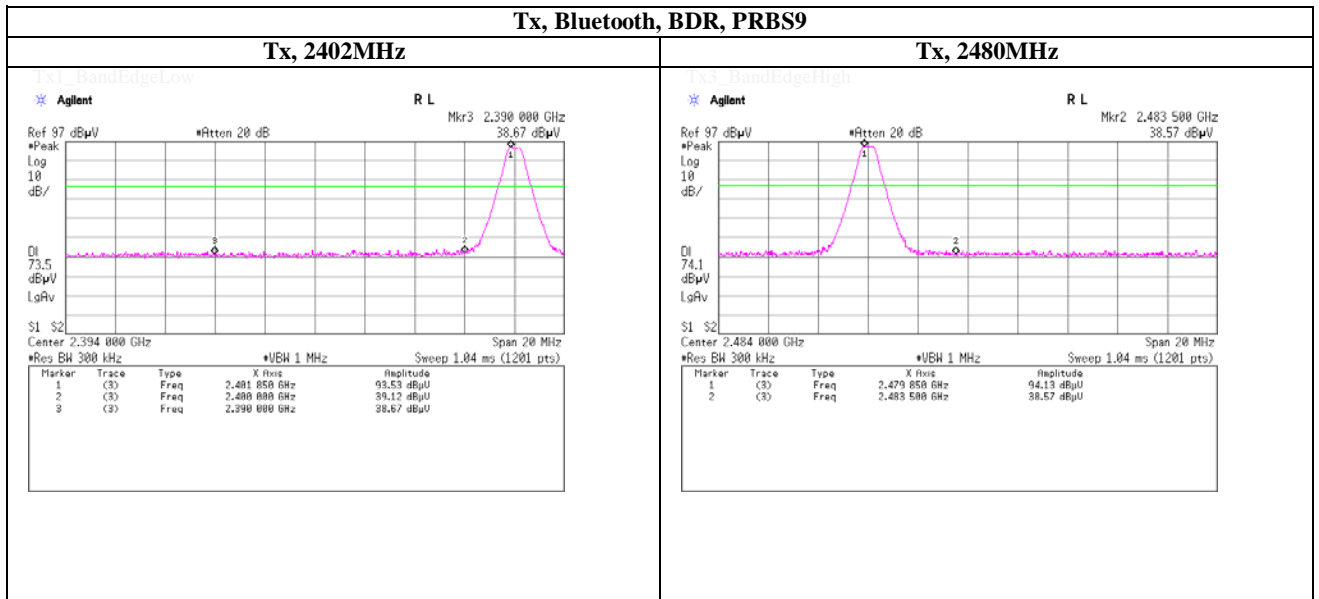

**UL Japan, Inc.**

**Shonan EMC Lab.**

1-22-3 Megumigaoka, Hiratsuka-shi, Kanagawa 259-1220 JAPAN

Telephone : +81 463 50 6400

Facsimile : +81 463 50 6401

## Spurious emission (Conducted)

Tx, Bluetooth, EDR, PRBS9

Tx, 2402MHz (below 1GHz)

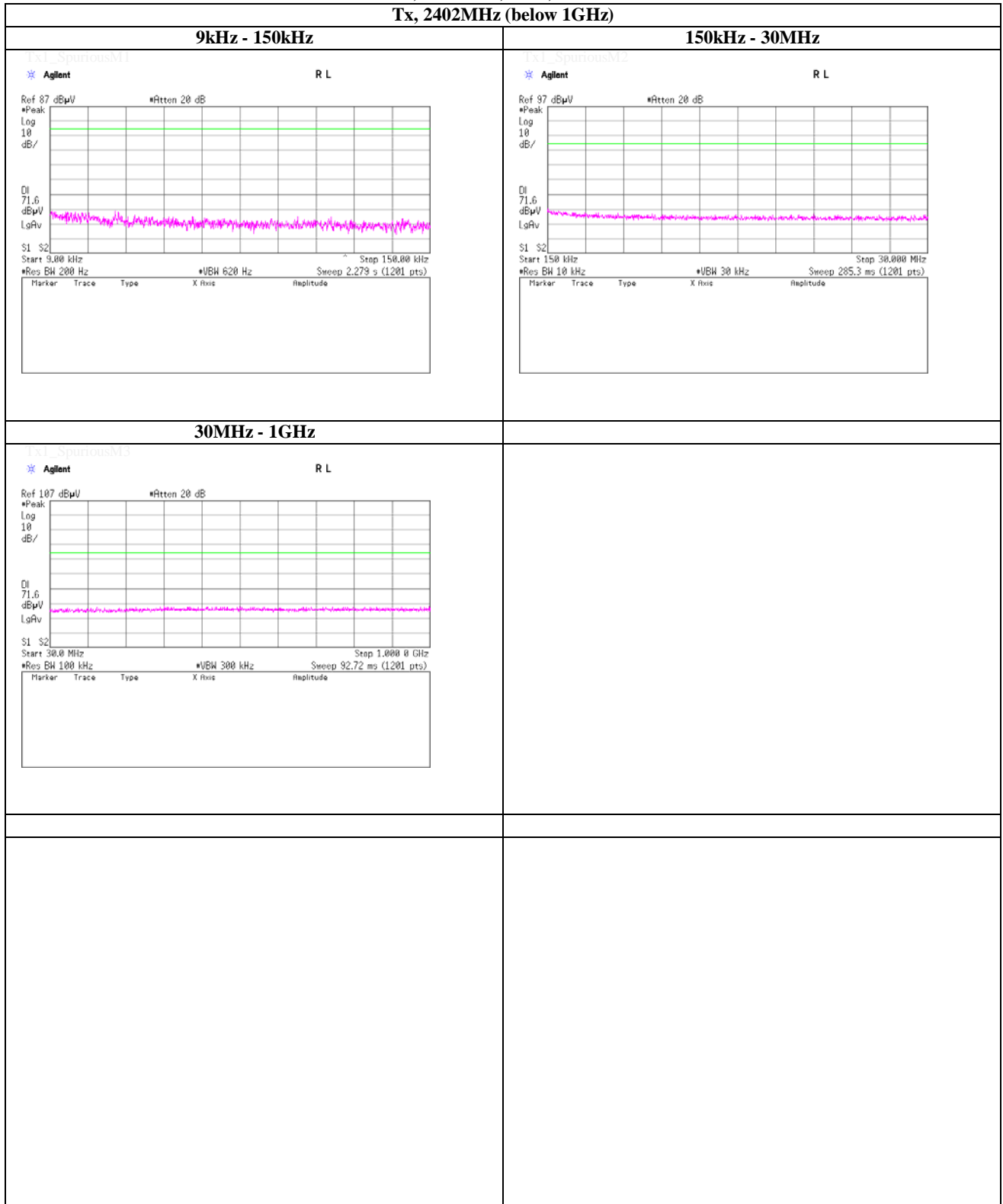

**UL Japan, Inc.**

**Shonan EMC Lab.**

1-22-3 Megumigaoka, Hiratsuka-shi, Kanagawa 259-1220 JAPAN

Telephone : +81 463 50 6400

Facsimile : +81 463 50 6401

### Spurious emission (Conducted)

Tx, Bluetooth, EDR, PRBS9

Tx, 2402MHz (above 1GHz)

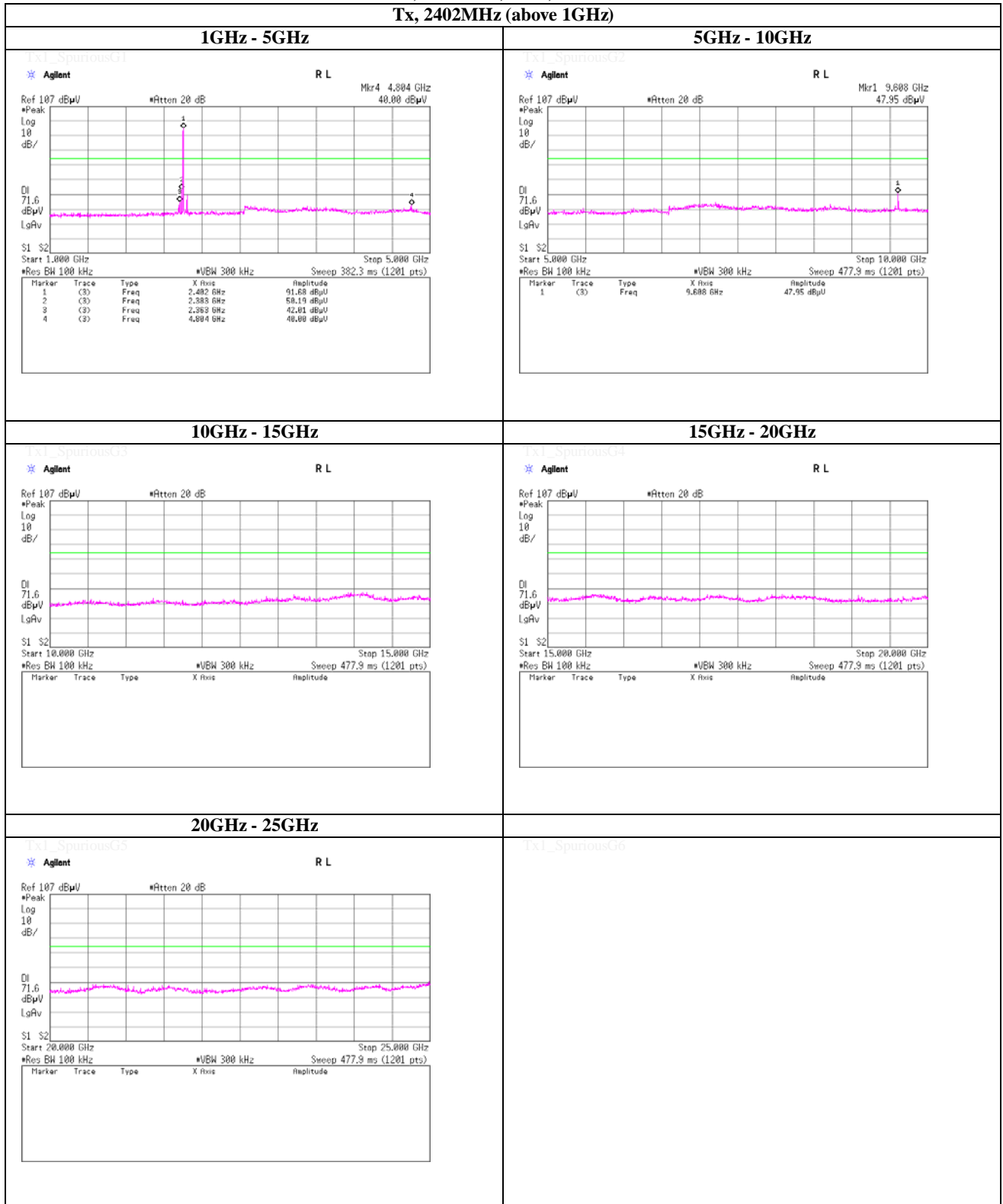

**UL Japan, Inc.**

**Shonan EMC Lab.**

1-22-3 Megumigaoka, Hiratsuka-shi, Kanagawa 259-1220 JAPAN

Telephone : +81 463 50 6400

Facsimile : +81 463 50 6401

## Spurious emission (Conducted)

Tx, Bluetooth, EDR, PRBS9

Tx, 2441MHz (below 1GHz)

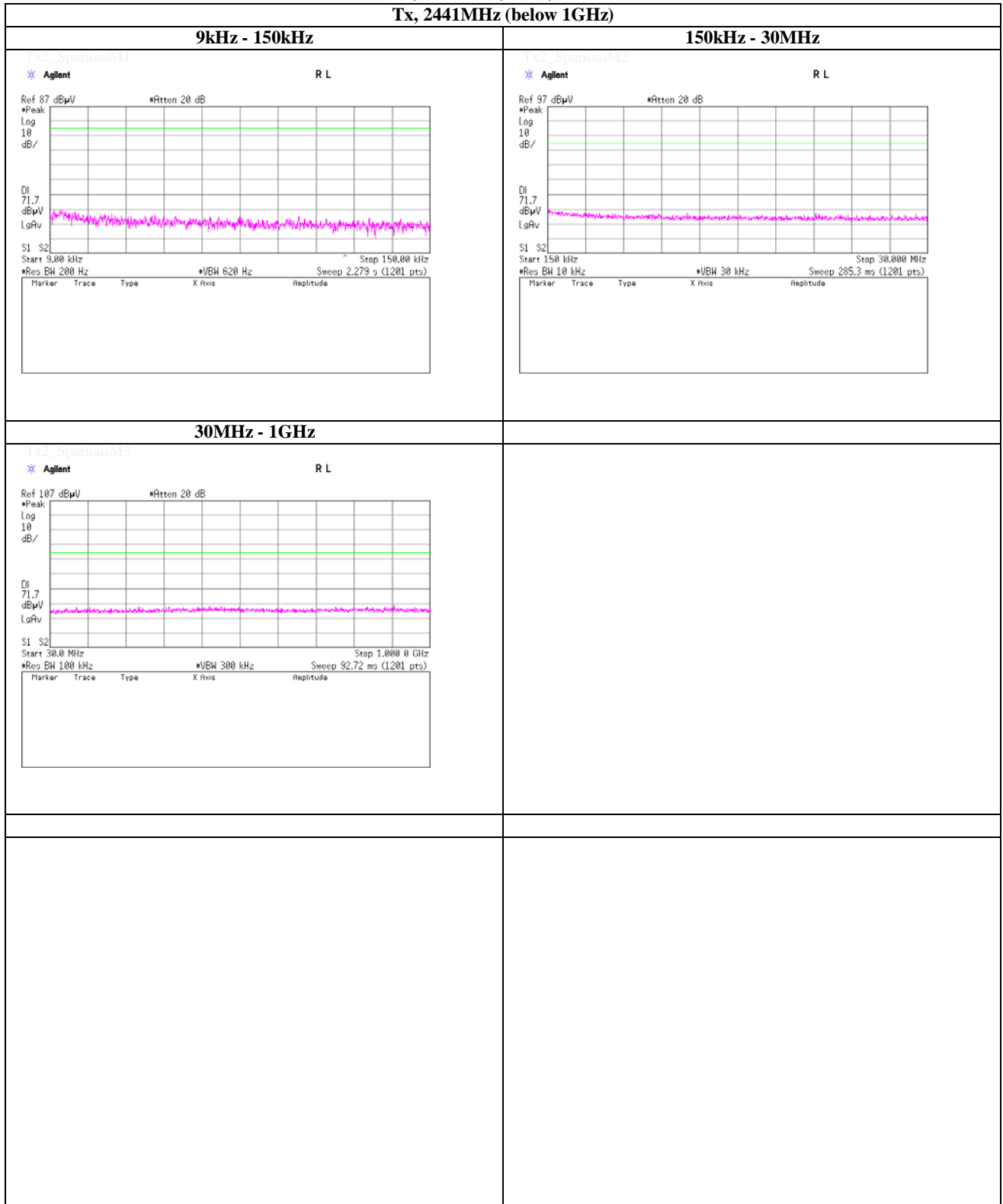

**UL Japan, Inc.**

**Shonan EMC Lab.**

1-22-3 Megumigaoka, Hiratsuka-shi, Kanagawa 259-1220 JAPAN

Telephone : +81 463 50 6400

Facsimile : +81 463 50 6401

### Spurious emission (Conducted)

Tx, Bluetooth, EDR, PRBS9

Tx, 2441MHz (above 1GHz)

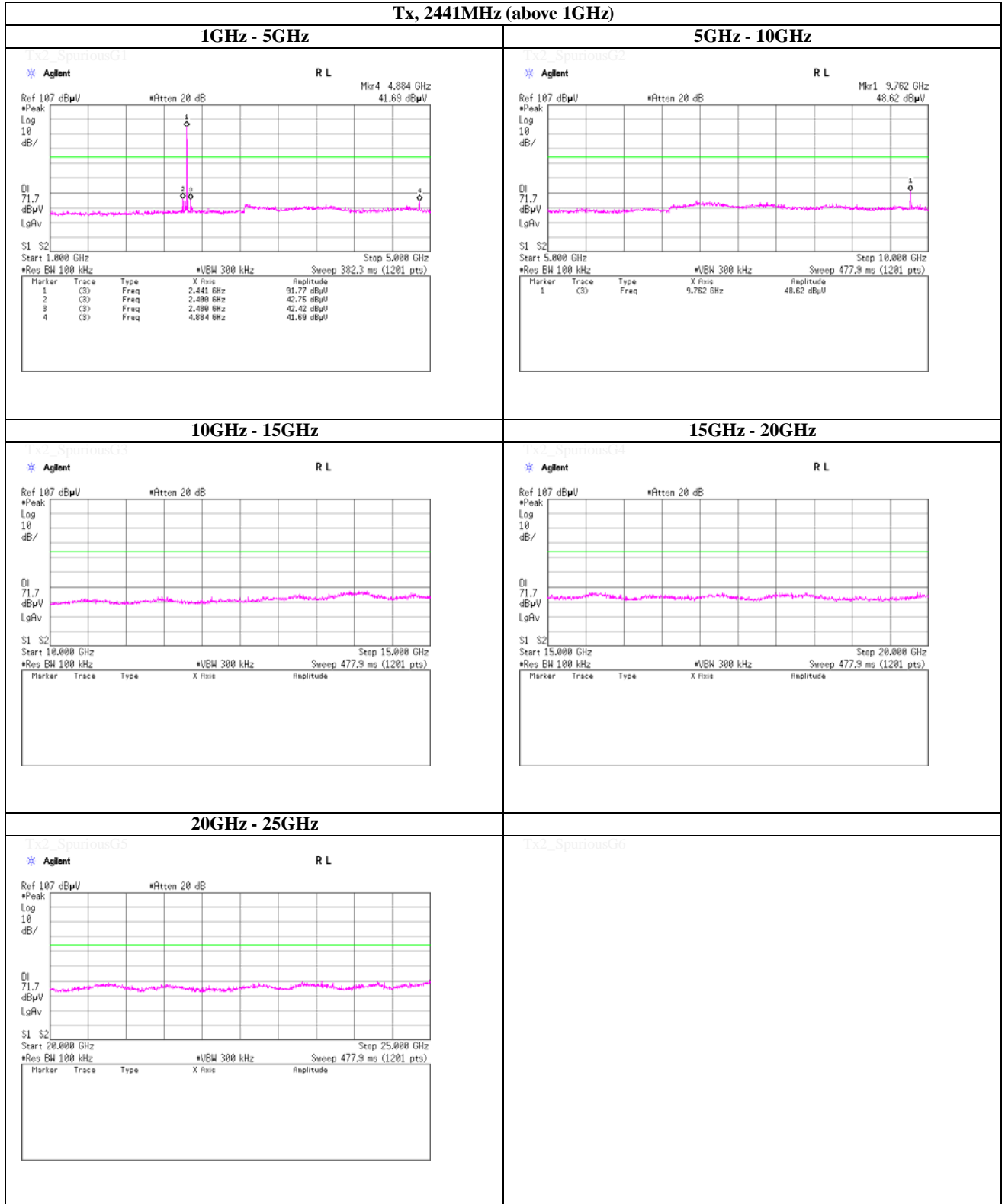

**UL Japan, Inc.**

**Shonan EMC Lab.**

1-22-3 Megumigaoka, Hiratsuka-shi, Kanagawa 259-1220 JAPAN

Telephone : +81 463 50 6400

Facsimile : +81 463 50 6401

## Spurious emission (Conducted)

Tx, Bluetooth, EDR, PRBS9

Tx, 2480MHz (below 1GHz)

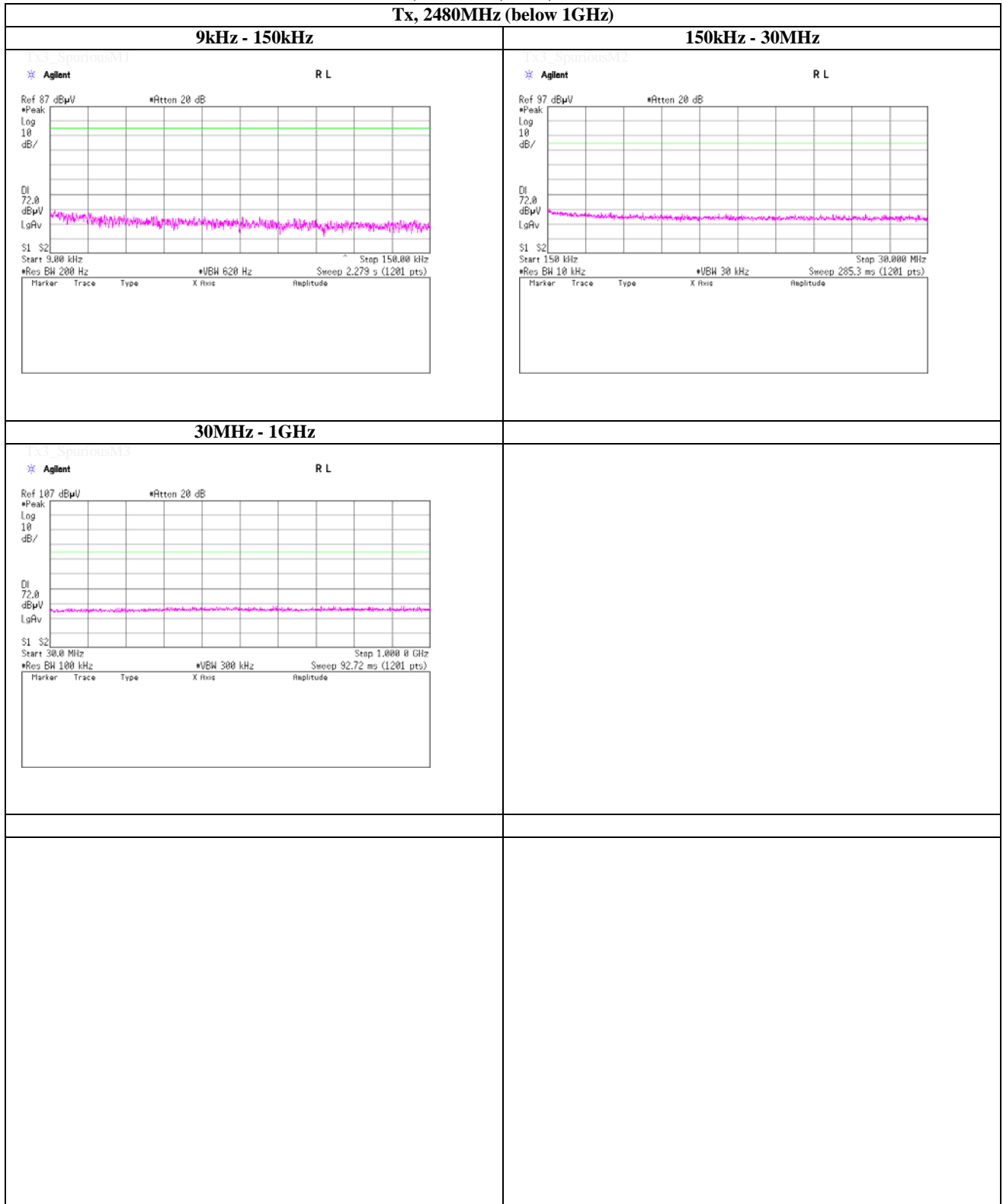

**UL Japan, Inc.**

**Shonan EMC Lab.**

1-22-3 Megumigaoka, Hiratsuka-shi, Kanagawa 259-1220 JAPAN

Telephone : +81 463 50 6400

Facsimile : +81 463 50 6401

### Spurious emission (Conducted)

Tx, Bluetooth, EDR, PRBS9

Tx, 2480MHz (above 1GHz)

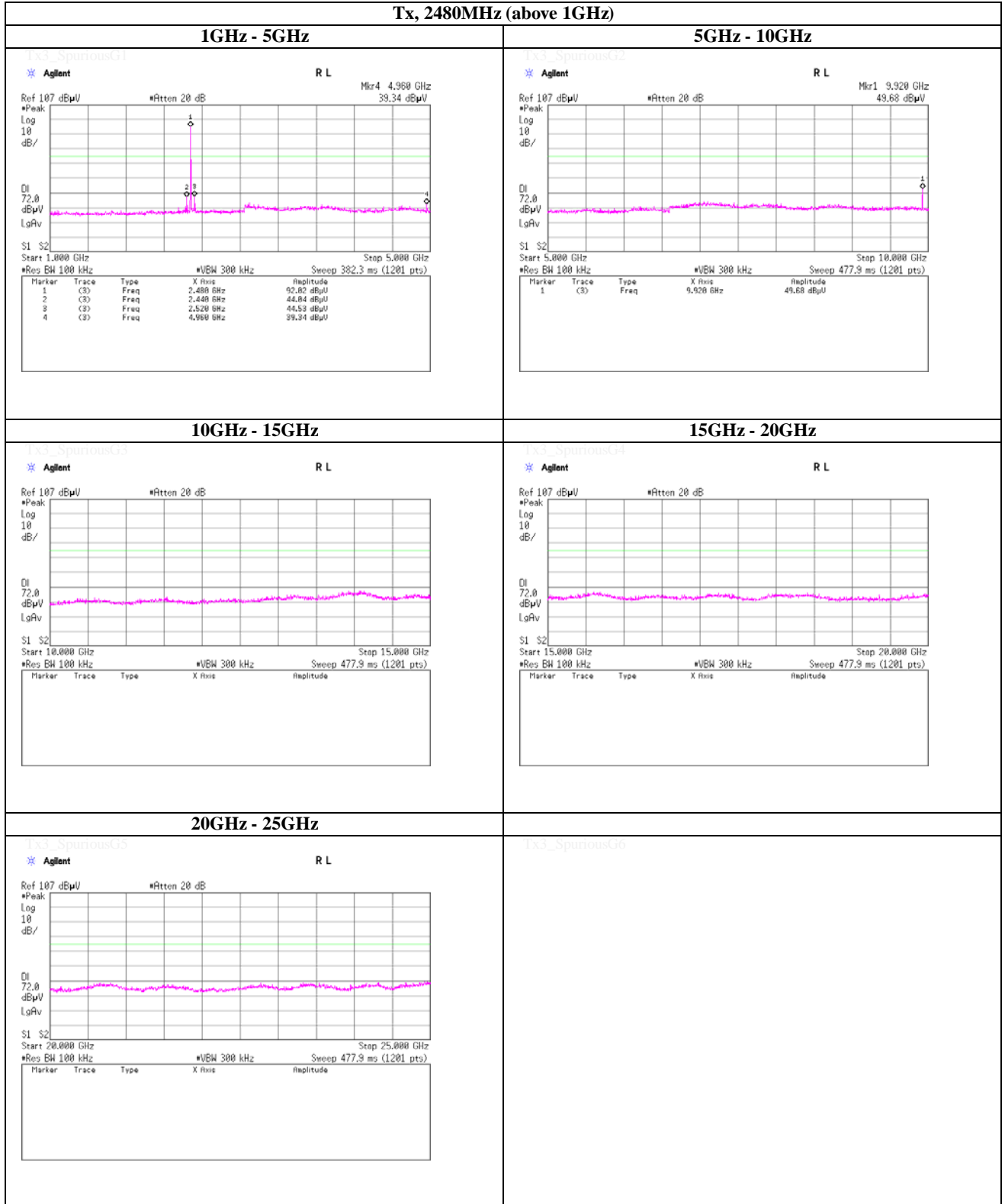

**UL Japan, Inc.**

**Shonan EMC Lab.**

1-22-3 Megumigaoka, Hiratsuka-shi, Kanagawa 259-1220 JAPAN

Telephone : +81 463 50 6400

Facsimile : +81 463 50 6401

## Spurious emission (Conducted)

### Band Edge compliance

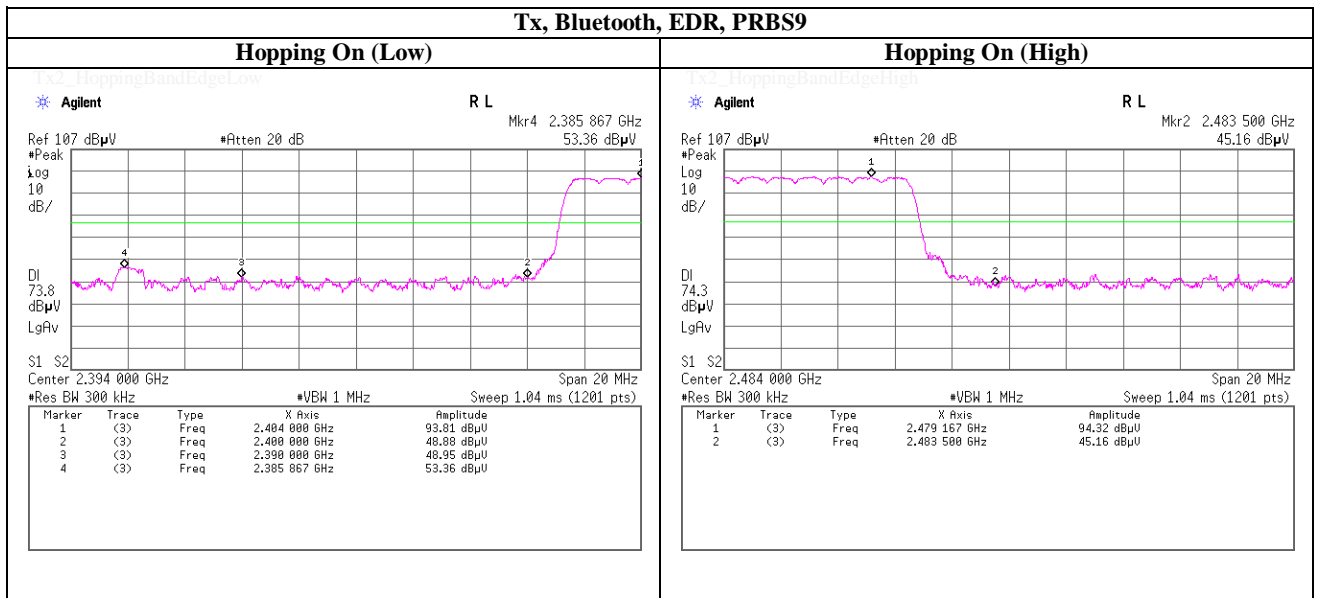
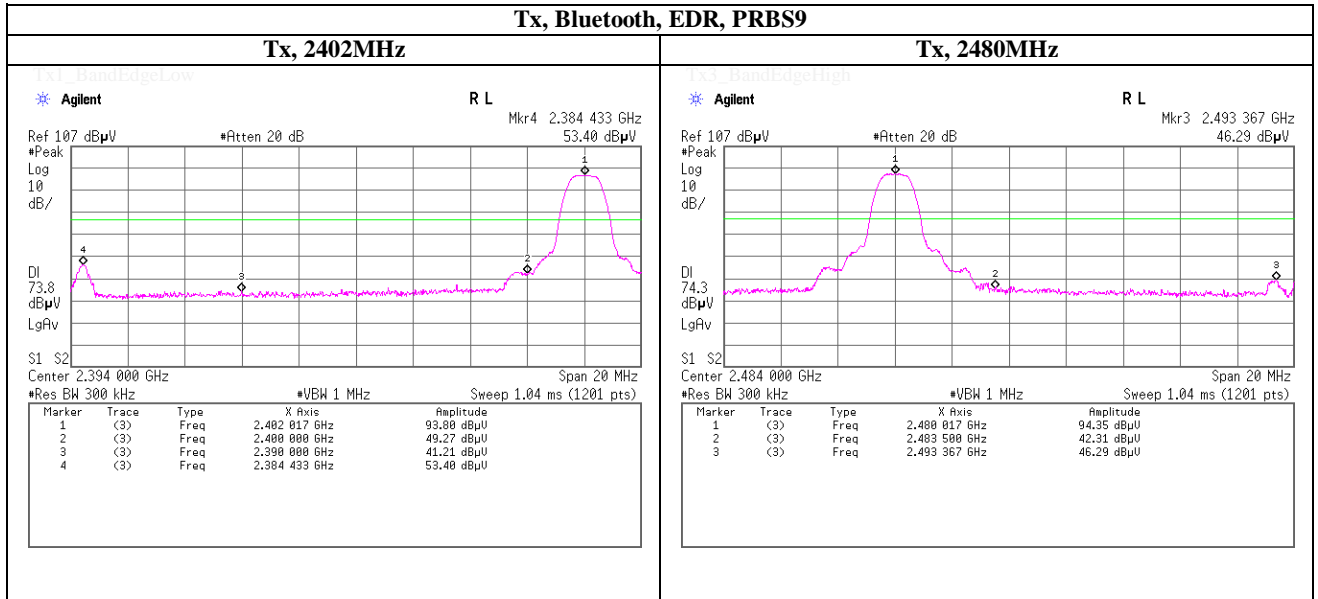

**UL Japan, Inc.**

**Shonan EMC Lab.**

1-22-3 Megumigaoka, Hiratsuka-shi, Kanagawa 259-1220 JAPAN

Telephone : +81 463 50 6400

Facsimile : +81 463 50 6401

## 99% Occupied Bandwidth

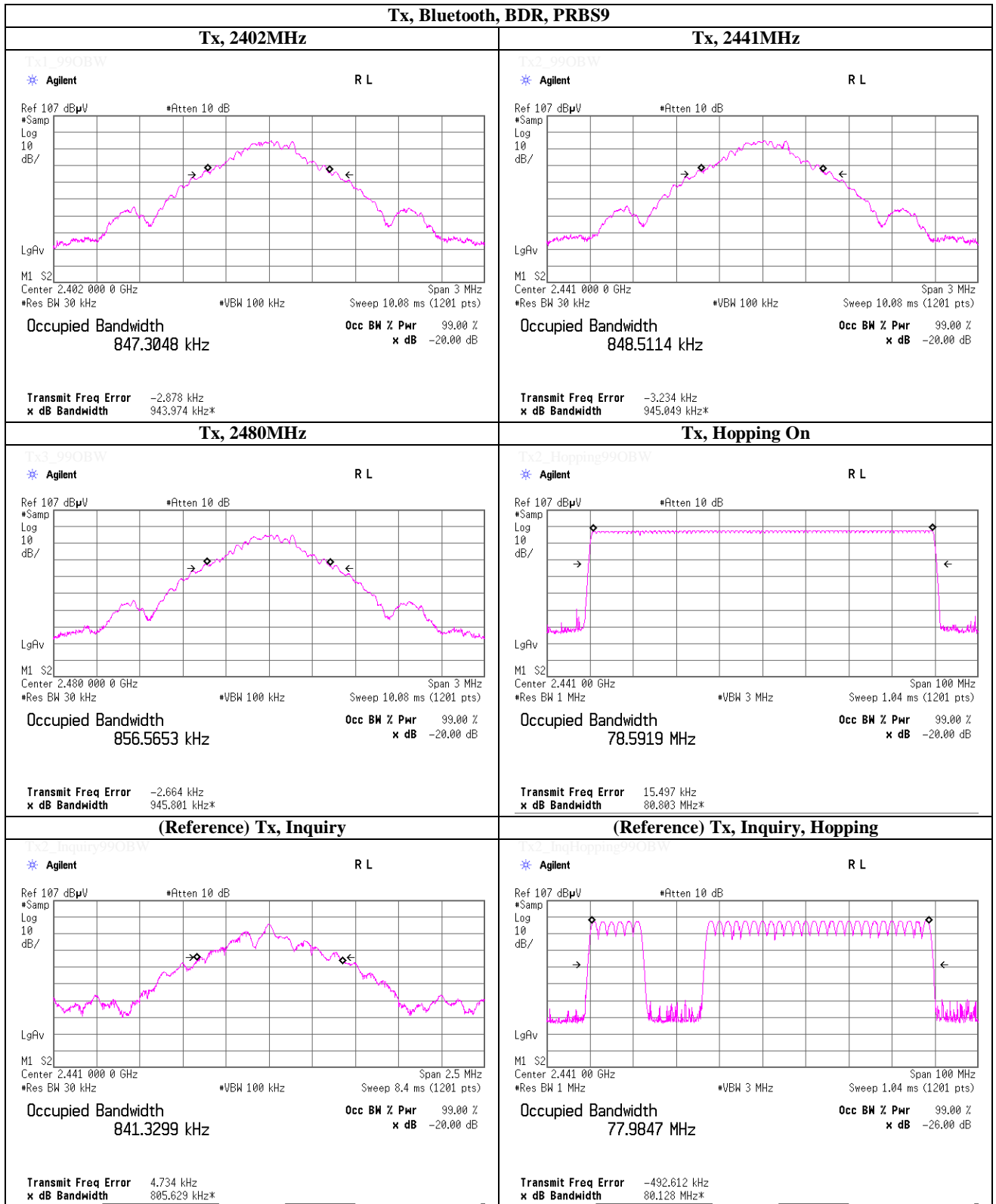

**UL Japan, Inc.**

**Shonan EMC Lab.**

1-22-3 Megumigaoka, Hiratsuka-shi, Kanagawa 259-1220 JAPAN

Telephone : +81 463 50 6400

Facsimile : +81 463 50 6401

### 99% Occupied Bandwidth

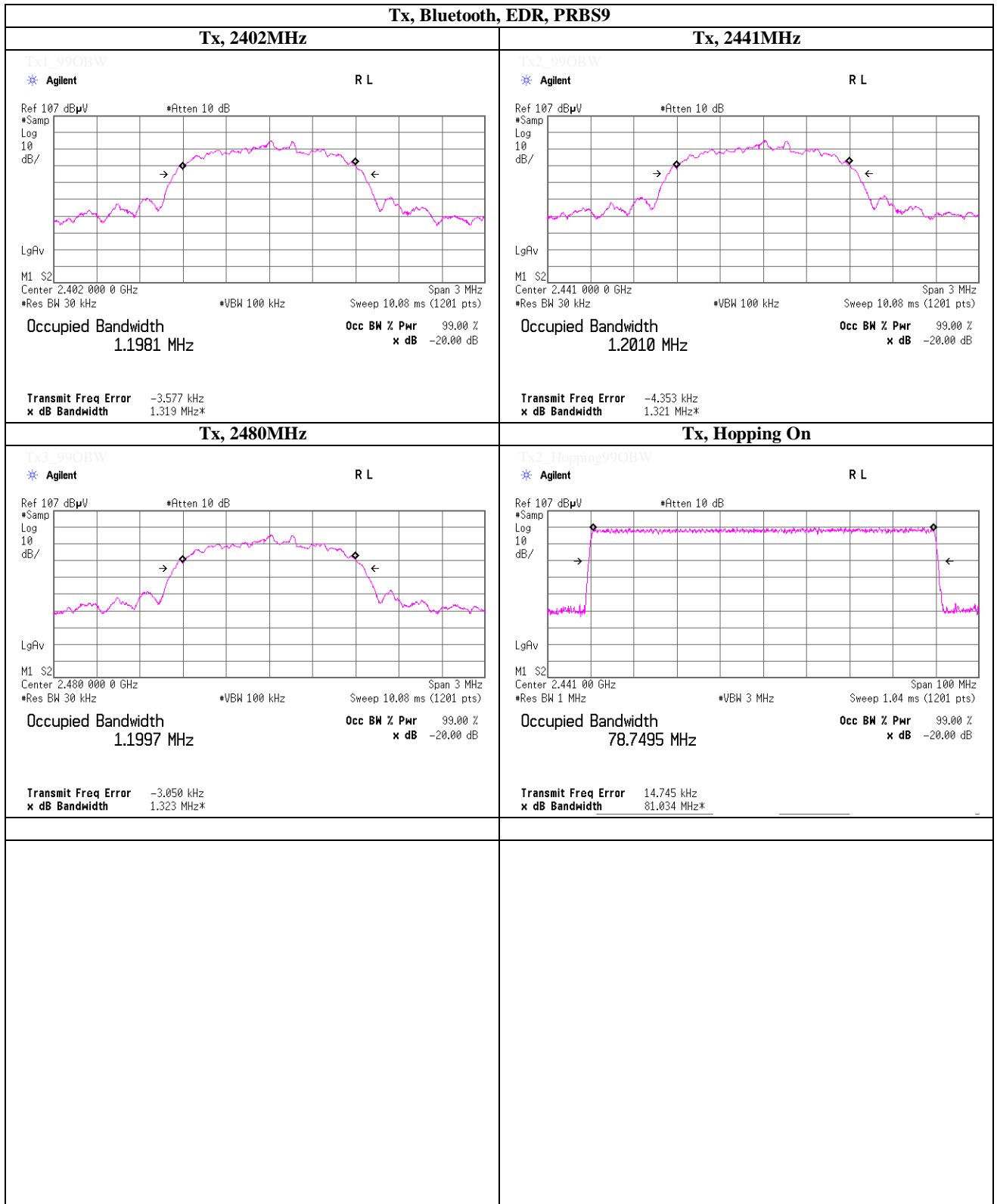

**UL Japan, Inc.**

**Shonan EMC Lab.**

1-22-3 Megumigaoka, Hiratsuka-shi, Kanagawa 259-1220 JAPAN

Telephone : +81 463 50 6400

Facsimile : +81 463 50 6401

Test Report No : 10005913S-A

## APPENDIX 2 Test Instruments

### EMI test equipment

Control No.	Instrument	Manufacturer	Model No	Serial No	Test Item	Calibration Date * Interval(month)
SAEC-03(NSA)	Semi-Anechoic Chamber	TDK	SAEC-03(NSA)	3	RE	2012/09/21 * 12
SAF-06	Pre Amplifier	TOYO Corporation	TPA0118-36	1440491	RE	2012/07/18 * 12
SCC-G03	Coaxial Cable	Suhner	SUCOFLEX 104A	46499/4A	RE	2012/04/10 * 12
SCC-G23	Coaxial Cable	Suhner	SUCOFLEX 104	297342/4	RE	2012/05/22 * 12
SHA-03	Horn Antenna	Schwarzbeck	BBHA9120D	9120D-739	RE	2012/08/17 * 12
SOS-06	Humidity Indicator	A&D	AD-5681	4062118	RE	2013/03/07 * 12
SSA-03	Spectrum Analyzer	Agilent	E4448A	MY48250152	RE	2013/01/08 * 12
SJM-11	Measure	PROMART	SEN1935	-	RE	-
COTS-SEMI-1	EMI Software	TSJ	TEPTO-DV(RE,CE, RFI,MF)	-	RE	-
SAT10-06	Attenuator	Agilent	8493C-010	74865	RE	2012/12/18 * 12
SFL-02	Highpass Filter	MICRO-TRONICS	HPM50111	051	RE	2012/12/18 * 12
SHA-04	Horn Antenna	ETS LINDGREN	3160-09	LM3640	RE	2012/03/30 * 12
SAF-08	Pre Amplifier	TOYO Corporation	HAP18-26W	00000019	RE	2012/03/12 * 12
SCC-G17	Coaxial Cable	Suhner	SUCOFLEX 104A	46291/4A	RE	2012/03/12 * 12
SAF-03	Pre Amplifier	SONOMA	310N	290213	RE	2013/02/12 * 12
SAT6-03	Attenuator	JFW	50HF-006N	-	RE	2013/02/12 * 12
SBA-03	Biconical Antenna	Schwarzbeck	BBA9106	91032666	RE	2012/10/08 * 12
SCC-C1/C2/C3/C4/C5/C10/SRSE-03	Coaxial Cable&RF Selector	Fujikura/Fujikura/Suhner/Suhner/Suhner/Suhner/TOYO	8D2W/12DSFA/141PE/141PE/141PE/141PE/NS4906	-/0901-271(RF Selector)	RE	2012/04/10 * 12
SLA-03	Logperiodic Antenna	Schwarzbeck	UHALP9108A	UHALP 9108-A0901	RE	2012/10/08 * 12
SOS-05	Humidity Indicator	A&D	AD-5681	4062518	RE	2013/02/27 * 12
STR-06	Test Receiver	Rohde & Schwarz	ESCI	101259	RE	2013/02/27 * 12
SSA-03	Spectrum Analyzer	Agilent	E4448A	MY48250152	AT	2013/01/08 * 12
SCC-G12	Coaxial Cable	Suhner	SUCOFLEX 102	30790/2	AT	2012/03/12 * 12
SAT10-11	Attenuator	Weinschel Corp.	54A-10	37588	AT	2012/04/06 * 12
SPM-06	Power Meter	Anritsu	ML2495A	0850009	AT	2012/04/19 * 12
SPSS-03	Power sensor	Anritsu	MA2411B	0917063	AT	2012/04/19 * 12
SOS-06	Humidity Indicator	A&D	AD-5681	4062118	AT	2013/03/07 * 12

The expiration date of the calibration is the end of the expired month .

As for some calibrations performed after the tested dates , those test equipment have been controlled by means of an unbroken chains of calibrations .

All equipment is calibrated with valid calibrations . Each measurement data is traceable to the national or international standards.

Test Item :

RE: Radiated emission,

AT: Antenna terminal conducted