





RADIO TEST REPORT

Test Report No. 15586918S-C-R1

Customer	Panasonic Automotive Systems Co., Ltd.
Description of EUT	Car Navigation
Model Number of EUT	AT2405
FCC ID	ACJ932AT2405
Test Regulation	FCC Part 15 Subpart E
Test Result	Complied
Issue Date	April 18, 2025
Remarks	WLAN (5 GHz band) part Maximum Conducted Output Power only *Spot check

Representative Test Engineer	Approved By
	
Shiro Kobayashi Engineer	Shinichi Takano Engineer
 	
CERTIFICATE 1266.03	
<input type="checkbox"/> The testing in which "Non-accreditation" is displayed is outside the accreditation scopes in UL Japan, Inc.	
<input checked="" type="checkbox"/> There is no testing item of "Non-accreditation".	

Report Cover Page - Form-ULID-003532 (DCS:13-EM-F0429) Issue# 24.0

ANNOUNCEMENT

- This test report shall not be reproduced in full or partial, without the written approval of UL Japan, Inc.
- The results in this report apply only to the sample tested. (Laboratory was not involved in sampling.)
- This sample tested is in compliance with the limits of the above regulation.
- The test results in this test report are traceable to the national or international standards.
- This test report must not be used by the customer to claim product certification, approval, or endorsement by the A2LA accreditation body.
- This test report covers Radio technical requirements.
It does not cover administrative issues such as Manual or non-Radio test related Requirements. (if applicable)
- The all test items in this test report are conducted by UL Japan, Inc. Shonan EMC Lab.
- The opinions and the interpretations to the result of the description in this report are outside scopes where UL Japan, Inc. has been accredited.
- The information provided by the customer for this report is identified in SECTION 1.
- The laboratory is not responsible for information provided by the customer which can impact the validity of the results.
- For test report(s) referred in this report, the latest version (including any revisions) is always referred.

REVISION HISTORY

Original Test Report No. 15586918S-C

This report is a revised version of 15586918S-C. 15586918S-C is replaced with this report.

Revision	Test Report No.	Date	Page Revised Contents
- (Original)	15586918S-C	December 23, 2024	-
1	15586918S-C-R1	April 18, 2025	P.22 Correction of minimum B value: From 38.294 to 38.306.

Reference: Abbreviations (Including words undescribed in this report)

A2LA	The American Association for Laboratory Accreditation	IEC	International Electrotechnical Commission
AC	Alternating Current	IEEE	Institute of Electrical and Electronics Engineers
AFH	Adaptive Frequency Hopping	IF	Intermediate Frequency
AM	Amplitude Modulation	ILAC	International Laboratory Accreditation Conference
Amp, AMP	Amplifier	ISED	Innovation, Science and Economic Development Canada
ANSI	American National Standards Institute	ISO	International Organization for Standardization
Ant, ANT	Antenna	JAB	Japan Accreditation Board
AP	Access Point	LAN	Local Area Network
ASK	Amplitude Shift Keying	LIMS	Laboratory Information Management System
Atten., ATT	Attenuator	MCS	Modulation and Coding Scheme
AV	Average	MRA	Mutual Recognition Arrangement
BPSK	Binary Phase-Shift Keying	N/A	Not Applicable
BR	Bluetooth Basic Rate	NIST	National Institute of Standards and Technology
BT	Bluetooth	NS	No signal detect.
BT LE	Bluetooth Low Energy	NSA	Normalized Site Attenuation
BW	BandWidth	NVLAP	National Voluntary Laboratory Accreditation Program
Cal Int	Calibration Interval	OBW	Occupied Band Width
CCK	Complementary Code Keying	OFDM	Orthogonal Frequency Division Multiplexing
Ch., CH	Channel	OFDMA	Orthogonal Frequency Division Multiple Access
CISPR	Comite International Special des Perturbations Radioelectriques	P/M	Power meter
CW	Continuous Wave	PCB	Printed Circuit Board
DBPSK	Differential BPSK	PER	Packet Error Rate
DC	Direct Current	PHY	Physical Layer
D-factor	Distance factor	PK	Peak
DFS	Dynamic Frequency Selection	PN	Pseudo random Noise
DQPSK	Differential QPSK	PP	Preamble Puncturing
DSSS	Direct Sequence Spread Spectrum	PRBS	Pseudo-Random Bit Sequence
EDR	Enhanced Data Rate	PSD	Power Spectral Density
EIRP, e.i.r.p.	Equivalent Isotropically Radiated Power	QAM	Quadrature Amplitude Modulation
EMC	ElectroMagnetic Compatibility	QP	Quasi-Peak
EMI	ElectroMagnetic Interference	QPSK	Quadri-Phase Shift Keying
EN	European Norm	RBW	Resolution Band Width
ERP, e.r.p.	Effective Radiated Power	RDS	Radio Data System
EU	European Union	RE	Radio Equipment
EUT	Equipment Under Test	RF	Radio Frequency
Fac.	Factor	RMS	Root Mean Square
FCC	Federal Communications Commission	RSS	Radio Standards Specifications
FHSS	Frequency Hopping Spread Spectrum	Rx	Receiving
FM	Frequency Modulation	SA, S/A	Spectrum Analyzer
Freq.	Frequency	SG	Signal Generator
FSK	Frequency Shift Keying	SVSWR	Site-Voltage Standing Wave Ratio
GFSK	Gaussian Frequency-Shift Keying	TR	Test Receiver
GNSS	Global Navigation Satellite System	Tx	Transmitting
GPS	Global Positioning System	VBW	Video BandWidth
Hori.	Horizontal	Vert.	Vertical
ICES	Interference-Causing Equipment Standard	WLAN	Wireless LAN

CONTENTS	PAGE
SECTION 1: Customer Information	5
SECTION 2: Equipment Under Test (EUT).....	5
SECTION 3: Test specification, Procedures & Results	7
SECTION 4: Operation of EUT during testing	9
SECTION 5: Antenna Terminal Conducted Tests.....	11
APPENDIX 1: Test Data	12
Maximum Conducted Output Power	12
APPENDIX 2: Test Instruments	36
APPENDIX 3: Photographs of Test Setup.....	37
Antenna Terminal Conducted Tests	37

SECTION 1: Customer Information

Company Name	Panasonic Automotive Systems Co., Ltd. *1)
Address	4261, Ikonobe-cho, Tsuzuki-ku, Yokohama-shi, Kanagawa-ken 224-8520, Japan
Telephone Number	+81-50-1802-5117
Contact Person	Daisuke Takahata

*1) The Grantee name in the FCC application is "Panasonic Corporation of North America".

The information provided by the customer is as follows;

- Customer, Description of EUT, Model Number of EUT, FCC ID on the cover and other relevant pages
- Operating/Test Mode(s) (Mode(s)) on all the relevant pages
- SECTION 1: Customer Information
- SECTION 2: Equipment Under Test (EUT) other than the Receipt Date and Test Date
- SECTION 4: Operation of EUT during testing

SECTION 2: Equipment Under Test (EUT)

2.1 Identification of EUT

Description	Car Navigation
Model Number	AT2405
Serial Number	Refer to SECTION 4.2
Condition	Production prototype (Not for Sale: This sample is equivalent to mass-produced items.)
Modification	No Modification by the test lab
Receipt Date	December 3, 2024
Test Date	December 5 to 8, 2024

2.2 Product Description

General Specification

Rating	DC 13.2 V
Operating temperature	-30 deg. C to +65 deg. C

Radio Specification

This report contains data provided by the customer which can impact the validity of results. UL Japan, Inc. is only responsible for the validity of results after the integration of the data provided by the customer. The data provided by the customer is marked "a)" in the table below.

Bluetooth (BR / EDR / BT LE)

Equipment Type	Transceiver
Frequency of Operation	2402 MHz to 2480 MHz
Type of Modulation	FHSS, GFSK / $\pi/4$ -DQPSK, 8DPSK / GFSK
Antenna Gain ^{a)}	4 dBi

WLAN (IEEE802.11b/11g/11n-20/11ax-20)

Equipment Type	Transceiver
Frequency of Operation	2412 MHz to 2462 MHz
Type of Modulation	DSSS, OFDM OFDMA: (20 MHz band): 26/52/106/242-tone RU
Antenna Gain ^{a)}	4 dBi

WLAN (IEEE802.11a/11n-20/11ac-20/11ax-20/11n-40/11ac-40/11ax-40/11ac-80/11ax-80)

Equipment Type	Transceiver	
Frequency of Operation	20 MHz Band	5180 MHz to 5240 MHz 5745 MHz to 5825 MHz
	40 MHz Band	5190 MHz to 5230 MHz 5755 MHz to 5795 MHz
	80 MHz Band	5210 MHz, 5775 MHz
Type of Modulation	OFDM	
	OFDMA (IEEE802.11ax only)	(20 MHz band): 26/52/106/242-tone RU
		(40 MHz band): 26/52/106/242/484-tone RU
(80 MHz band): 26/52/106/242/484/996-tone RU		
Antenna Gain ^{a)}	RF0: 5 dBi, RF1: 5 dBi	

SECTION 3: Test specification, Procedures & Results

3.1 Test Specification

Test Specification	FCC Part 15 Subpart E The latest version on the first day of the testing period
Title	FCC 47 CFR Part 15 Radio Frequency Device Subpart E Unlicensed National Information Infrastructure Devices Section 15.407 General technical requirements

3.2 Procedures and Results

Item	Test Procedure	Specification	Worst Margin	Results	Remarks
Maximum Conducted Output Power	FCC: KDB Publication Number 789033	FCC: 15.407 (a) (1) (2) (3)	See data	Complied	Conducted
	ISED: -	ISED: RSS-247 6.2			
Note: UL Japan, Inc.'s EMI Work Procedures: Work Instructions-ULID-003591 and Work Instructions-ULID-003593. * In case any questions arise about test procedure, ANSI C63.10: 2013 is also referred.					

FCC Part 15.31 (e)

The EUT provides stable voltage constantly to the wireless transmitter regardless of input voltage. Instead of a new battery, DC power supply was used for the test. That does not affect the test result, therefore the EUT complies with the requirement.

FCC Part 15.203 Antenna requirement

It is impossible for end users to replace the antenna, because the antenna is mounted inside of the EUT. Therefore, the equipment complies with the antenna requirement of Section 15.203.

3.3 Addition to Standard

No addition, exclusion nor deviation has been made from the standard.

3.4 Uncertainty

Measurement uncertainty is not taken into account when stating conformity with a specified requirement. Note: When margins obtained from test results are less than the measurement uncertainty, the test results may exceed the limit.

The following uncertainties have been calculated to provide a confidence level of 95 % using a coverage factor $k=2$.

Antenna terminal test	Uncertainty (+/-)
Power Measurement above 1 GHz (Average Detector)	1.3 dB
Power Measurement above 1 GHz (Peak Detector)	1.5 dB
Spurious Emission (Conducted) below 1 GHz	0.93 dB
Conducted Emissions Power Density Measurement 1 GHz to 3 GHz	0.93 dB
Conducted Emissions Power Density Measurement 3 GHz to 18 GHz	3.0 dB
Spurious Emission (Conducted) 18 GHz to 26.5 GHz	2.8 dB
Spurious Emission (Conducted) 26.5 GHz to 40 GHz	2.3 dB
Bandwidth Measurement	0.012 %
Duty Cycle and Time Measurement	0.27 %
Temperature	2.2 deg.C.
Humidity	3.4 %
Voltage	0.92 %

3.5 Test Location

UL Japan, Inc. Shonan EMC Lab.

1-22-3, Megumigaoka, Hiratsuka-shi, Kanagawa-ken 259-1220 Japan

Telephone: +81-463-50-6400

A2LA Certificate Number: 1266.03

(FCC test firm registration number: 626366, ISED lab company number: 2973D / CAB identifier: JP0001)

Test room	Width x Depth x Height (m)	Size of reference ground plane (m) / horizontal conducting plane	Maximum measurement distance
No.1 Semi-anechoic chamber (SAC1)	20.6 x 11.3 x 7.65	20.6 x 11.3	10 m
No.2 Semi-anechoic chamber (SAC2)	20.6 x 11.3 x 7.65	20.6 x 11.3	10 m
No.3 Semi-anechoic chamber (SAC3)	12.7 x 7.7 x 5.35	12.7 x 7.7	5 m
No.4 Semi-anechoic chamber (SAC4)	8.1 x 5.1 x 3.55	8.1 x 5.1	-
Wireless anechoic chamber 1 (WAC1)	9.5 x 6.0 x 5.4	9.5 x 6.0	3 m
Wireless anechoic chamber 2 (WAC2)	9.5 x 6.0 x 5.4	9.5 x 6.0	3 m
No.1 Shielded room	6.8 x 4.1 x 2.7	6.8 x 4.1	-
No.2 Shielded room	6.8 x 4.1 x 2.7	6.8 x 4.1	-
No.3 Shielded room	6.3 x 4.7 x 2.7	6.3 x 4.7	-
No.4 Shielded room	4.4 x 4.7 x 2.7	4.4 x 4.7	-
No.5 Shielded room	7.8 x 6.4 x 2.7	7.8 x 6.4	-
No.6 Shielded room	7.8 x 6.4 x 2.7	7.8 x 6.4	-
No.8 Shielded room	3.45 x 5.5 x 2.4	3.45 x 5.5	-
No.1 Measurement room	2.55 x 4.1 x 2.5	-	-
No.2 Measurement room	4.5 x 3.5 x 2.5	-	-
Wireless shielded room 1	3.0 x 4.5 x 2.7	3.0 x 4.5	-
Wireless shielded room 2	3.0 x 4.5 x 2.7	3.0 x 4.5	-

3.6 Test Data, Test Instruments, and Test Set Up

Refer to APPENDIX.

SECTION 4: Operation of EUT during testing

4.1 Operating Mode(s)

Mode	Remarks*
IEEE 802.11a (11a)	54 Mbps, PN9
IEEE 802.11n MIMO 20 MHz BW (11n-20)	MCS 14 (GI 800 ns), PN9
IEEE 802.11ac MIMO 20 MHz BW (11ac-20)	MCS 5 (GI 800 ns, 2 SS), PN9
IEEE 802.11ax MIMO 20 MHz BW (11ax-20)	MCS 5 (GI 1600 ns, 2 SS), PN9
IEEE 802.11n MIMO 40 MHz BW (11n-40)	MCS 13 (GI 800 ns), PN9
IEEE 802.11ac MIMO 40 MHz BW (11ac-40)	MCS 5 (GI 800 ns, 2 SS), PN9
IEEE 802.11ax MIMO 40 MHz BW (11ax-40)	MCS 10 (GI 1600 ns, 2 SS), PN9
IEEE 802.11ac MIMO 80 MHz BW (11ac-80)	MCS 5 (GI 800 ns, 2 SS), PN9
IEEE 802.11ax MIMO 80 MHz BW (11ax-80)	MCS 7 (GI 1600 ns, 2 SS), PN9
*The worst condition was determined based on the test result of Conducted Output Power and 99 % Occupied Bandwidth referenced the original report. (Reference test report No.: 14747914S-C)	
*Power of the EUT was set by the software as follows; Power See the below table Setting: Software: wifi_5g_serial Version 1003 (Date: 2024.10.08, Storage location: Driven by connected PC) OFDMA_TX_5G_Serial_Version 1003 (Date: 2024.10.08, Storage location: Driven by connected PC)	
*This setting of software is the worst case. Any conditions under the normal use do not exceed the condition of setting. In addition, end users cannot change the settings of the output power of the product.	
Test operating mode was determined as follows according to "Section 1 of 6 802.11 a/b/g/n testing - Managing Complex Regulatory Approvals - " of TCB Council Workshop October 2009 and also was judged the necessity of 802.11ac/ax mode by the pre-test.	

Power Setting:

		TPC function: OFF			TPC function: ON		
		20 MHz BW	40 MHz BW	80 MHz BW	20 MHz BW	40 MHz BW	80 MHz BW
OFDM		3.0	2.5	2.0	-1.0	-1.5	-2.0
OFDMA	26-tone RU	2.0	2.0	2.0	-2.0	-2.0	-2.0
	52-tone RU	3.0	2.5	2.0	-1.0	-1.5	-2.0
	106-tone RU	3.0	2.5	2.0	-1.0	-1.5	-2.0
	242-tone RU	3.0	2.5	2.0	-1.0	-1.5	-2.0
	484-tone RU	-	2.5	2.0	-	-1.5	-2.0
	996-tone RU	-	-	2.0	-	-	-2.0

*The Details of Operation Mode(s)

Test Item	Operating Mode	Tested Antenna	Tested Frequency	
			Lower Band	Upper Band
Maximum Conducted Output Power	Tx 11a Tx 11n-20 Tx 11ac-20 Tx 11ax-20 (OFDM) Tx 11ax-20 (OFDMA)	RF0 + RF1	5180 MHz 5220 MHz 5240 MHz	5745 MHz 5785 MHz 5825 MHz
	Tx 11n-40 Tx 11ac-40 Tx 11ax-40 (OFDM) Tx 11ax-40 (OFDMA)	RF0 + RF1	5190 MHz 5230 MHz	5755 MHz 5795 MHz
	Tx 11ac-80 Tx 11ax-80 (OFDM) Tx 11ax-80 (OFDMA)	RF0 + RF1	5210 MHz	5775 MHz

4.2 Configuration and Peripherals

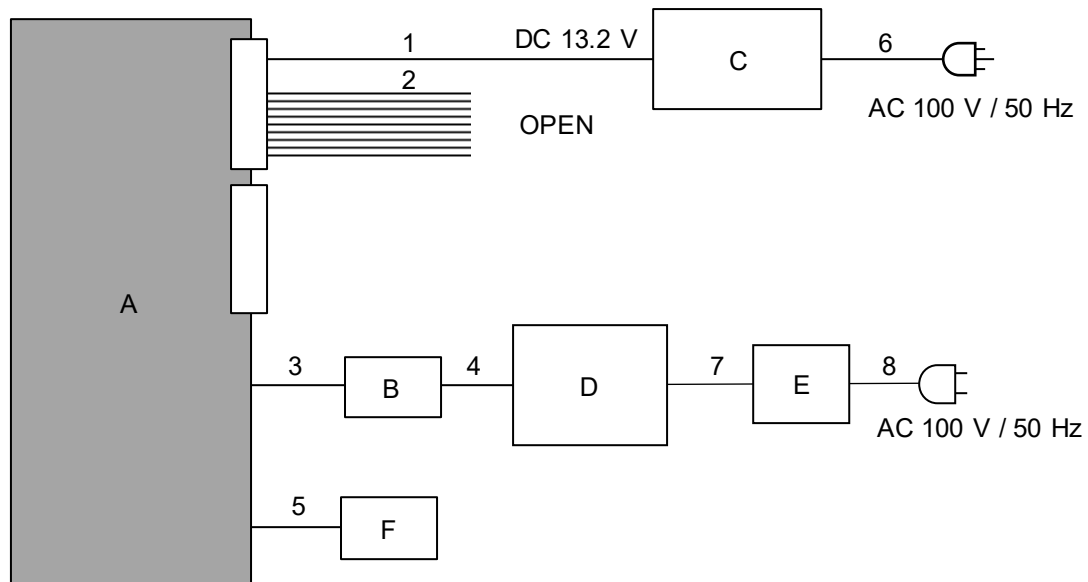

Description of EUT and Support Equipment

No.	Item	Model number	Serial Number	Manufacturer	Remarks
A	Car Navigation	AT2405	500024	Panasonic	EUT
B	Jig Board	-	-	-	-
C	Power Supply(DC)	PAN35-10A	NA000955	KIKUSUI	-
D	Laptop Computer	Compaq 6730b	CNU01346XD	HP	-
E	AC Adapter	PPP014L-SA	8213890309	HP	-
F	Jig Board	-	-	-	-

List of Cables Used

No.	Name	Length (m)	Shield		Remarks
			Cable	Connector	
1	DC	3.0	Unshielded	Unshielded	-
2	Signal	3.0	Unshielded	Unshielded	-
3	Signal	0.1	Unshielded	Unshielded	-
4	USB	0.8	Shielded	Shielded	-
5	Signal	0.1	Unshielded	Unshielded	-
6	AC	2.0	Unshielded	Unshielded	-
7	DC	1.8	Unshielded	Unshielded	-
8	AC	1.8	Unshielded	Unshielded	-

SECTION 5: Antenna Terminal Conducted Tests

Test Procedure

The tests were made with below setting connected to the antenna port.

Test	Span	RBW	VBW	Sweep time	Detector	Trace	Instrument used and Test method
Maximum Conducted Output Power	-	-	-	Auto	Average	-	Power Meter (Sensor: 160 MHz BW) (Method PM-G)

Test results are rounded off and limit are rounded down, so some differences might be observed.
The equipment and cables were not used for factor 0 dB of the data sheets.

Test Data : **APPENDIX**
Test Result : **Pass**

APPENDIX 1: Test Data

Maximum Conducted Output Power

Test place	Shonan EMC Lab.
Mode	Tx 11a, TPC Function: Off

Date	Test Place	Temperature	Humidity	Engineer
December 5, 2024	No.8 Shielded room	24 deg.C	38 %RH	Makoto Hosaka

11a

RF0 + RF1

Applied limit: FCC 15.407: mobile and portable client device, RSS-247: OEM devices installed in vehicles

Tested Freq. [MHz]	Antenna			Result [dBm]	Conducted power				Antenna			Result [dBm]	e.i.r.p.			
	RF0 [mW]	RF1 [mW]	Sum [mW]		FCC 15.407 Limit [dBm]	FCC 15.407 Margin [dB]	RSS-247 Limit [dBm]	RSS-247 Margin [dB]	RF0 [mW]	RF1 [mW]	Sum [mW]		FCC 15.407 Limit [dBm]	FCC 15.407 Margin [dB]	RSS-247 Limit [dBm]	RSS-247 Margin [dB]
5180	2.18	2.59	4.77	6.79	23.97	17.18	-	-	6.89	8.20	15.09	11.79	29.97	18.18	14.00	2.21
5220	2.37	2.75	5.12	7.09	23.97	16.88	-	-	7.48	8.71	16.19	12.09	29.97	17.88	14.00	1.91
5240	2.37	2.75	5.12	7.09	23.97	16.88	-	-	7.50	8.69	16.19	12.09	29.97	17.88	14.00	1.91
5745	2.48	2.86	5.34	7.28	30.00	22.72	30.00	22.72	7.85	9.04	16.89	12.28	36.00	23.72	36.00	23.72
5785	2.48	2.72	5.20	7.16	30.00	22.84	30.00	22.84	7.83	8.61	16.44	12.16	36.00	23.84	36.00	23.84
5825	2.49	2.91	5.40	7.32	30.00	22.68	30.00	22.68	7.87	9.20	17.07	12.32	36.00	23.68	36.00	23.68

Tested Freq. [MHz]	RF0						RF1						
	Reading [dBm]	Cable Loss [dB]	Atten. Loss [dB]	Directional Gain [dBi]	Cond. Power [dBm]	e.i.r.p. [dBm]	Reading [dBm]	Cable Loss [dB]	Atten. Loss [dB]	Directional Gain [dBi]	Cond. Power [dBm]	e.i.r.p. [dBm]	
5180	-	-10.85	4.29	9.94	5.00	3.38	8.38	-9.86	4.28	9.72	5.00	4.14	9.14
5220	-	-10.49	4.29	9.94	5.00	3.74	8.74	-9.61	4.29	9.72	5.00	4.40	9.40
5240	-	-10.50	4.31	9.94	5.00	3.75	8.75	-9.63	4.30	9.72	5.00	4.39	9.39
5745	-	-10.54	4.54	9.95	5.00	3.95	8.95	-9.72	4.54	9.74	5.00	4.56	9.56
5785	-	-10.57	4.56	9.95	5.00	3.94	8.94	-9.95	4.56	9.74	5.00	4.35	9.35
5825	-	-10.58	4.59	9.95	5.00	3.96	8.96	-9.69	4.59	9.74	5.00	4.64	9.64

Sample Calculation:

Conducted Power Result = Reading + Cable Loss (including the cable(s) customer supplied) + Atten. Loss

e.i.r.p. Result = Conducted Power Result + Directional Gain

Directional Gain = G_{ANT} + Array Gain

Array Gain = 0 dB (i.e., no array gain) $N_{ANT} \leq 4$, N_{ANT} = number of transmit antennas = 2

15.407 Limit

Conducted Power Limit (5150 MHz-5250 MHz) = 250 mW

Conducted Power Limit (5725 MHz-5850 MHz) = 1 W

RSS-247 Limit

Conducted Power Limit (5725 MHz-5850 MHz) = 1 W

e.i.r.p. Limit (5150 MHz-5250 MHz) = 30 mW or $(1.76 + 10\log B)$ dBm, whichever is lower

For all test frequencies, B was applied the minimum value (16.783 MHz) as conservative limit.

Although the EUT operates on Master mode, more stringent limit for Client device was applied. (U-NII-1 for FCC)

The test was performed with Gate function.

Maximum Conducted Output Power

Test place	Shonan EMC Lab.
Mode	Tx 11n-20, TPC Function: Off

Date	Test Place	Temperature	Humidity	Engineer
December 5, 2024	No.8 Shielded room	24 deg.C	38 %RH	Makoto Hosaka

11n-20

RF0 + RF1

Applied limit: FCC 15.407: mobile and portable client device, RSS-247: OEM devices installed in vehicles

Tested Freq. [MHz]	Antenna			Conducted power				e.i.r.p.								
	RF0 [mW]	RF1 [mW]	Sum [mW]	Result [dBm]	FCC 15.407 Limit [dBm]	Margin [dB]	RSS-247 Limit [dBm]	Margin [dB]	RF0 [mW]	RF1 [mW]	Sum [mW]	Result [dBm]	FCC 15.407 Limit [dBm]	Margin [dB]	RSS-247 Limit [dBm]	Margin [dB]
5180	2.19	2.62	4.81	6.82	23.97	17.15	-	-	6.93	8.28	15.21	11.82	29.97	18.15	14.30	2.48
5220	2.44	2.82	5.27	7.22	23.97	16.75	-	-	7.73	8.93	16.66	12.22	29.97	17.75	14.30	2.08
5240	2.33	2.71	5.04	7.03	23.97	16.94	-	-	7.38	8.57	15.95	12.03	29.97	17.94	14.30	2.27
5745	2.56	2.90	5.46	7.37	30.00	22.63	30.00	22.63	8.09	9.16	17.25	12.37	36.00	23.63	36.00	23.63
5785	2.52	2.69	5.22	7.17	30.00	22.83	30.00	22.83	7.98	8.51	16.49	12.17	36.00	23.83	36.00	23.83
5825	2.46	2.87	5.33	7.27	30.00	22.73	30.00	22.73	7.78	9.08	16.86	12.27	36.00	23.73	36.00	23.73

Tested Freq. [MHz]	RF0							RF1						
	Reading [dBm]	Cable Loss [dB]	Atten. Loss [dB]	Antenna Gain [dBi]	Result Cond. Power [dBm]	Result e.i.r.p. [dBm]	Reading [dBm]	Cable Loss [dB]	Atten. Loss [dB]	Antenna Gain [dBi]	Result Cond. Power [dBm]	Result e.i.r.p. [dBm]		
5180	-	-10.82	4.29	9.94	5.00	3.41	8.41	-9.82	4.28	9.72	5.00	4.18	9.18	
5220	-	-10.35	4.29	9.94	5.00	3.88	8.88	-9.50	4.29	9.72	5.00	4.51	9.51	
5240	-	-10.57	4.31	9.94	5.00	3.68	8.68	-9.69	4.30	9.72	5.00	4.33	9.33	
5745	-	-10.41	4.54	9.95	5.00	4.08	9.08	-9.66	4.54	9.74	5.00	4.62	9.62	
5785	-	-10.49	4.56	9.95	5.00	4.02	9.02	-10.00	4.56	9.74	5.00	4.30	9.30	
5825	-	-10.63	4.59	9.95	5.00	3.91	8.91	-9.75	4.59	9.74	5.00	4.58	9.58	

Sample Calculation:

Conducted Power Result = Reading + Cable Loss (including the cable(s) customer supplied) + Atten. Loss
e.i.r.p. Result = Conducted Power Result + Antenna Gain

15.407 Limit

Conducted Power Limit (5150 MHz-5250 MHz) = 250 mW
Conducted Power Limit (5725 MHz-5850 MHz) = 1 W

RSS-247 Limit

Conducted Power Limit (5725 MHz-5850 MHz) = 1 W
e.i.r.p. Limit (5150 MHz-5250 MHz) = 30 mW or (1.76 + 10logB) dBm, whichever is lower
For all test frequencies, B was applied the minimum value (17.976 MHz) as conservative limit.

Although the EUT operates on Master mode, more stringent limit for Client device was applied. (U-NII-1 for FCC)
The test was performed with Gate function.

Maximum Conducted Output Power

Test place	Shonan EMC Lab.
Mode	Tx 11ac-20, TPC Function: Off

Date	Test Place	Temperature	Humidity	Engineer
December 5, 2024	No.8 Shielded room	24 deg.C	38 %RH	Makoto Hosaka

11ac-20

RF0 + RF1

Applied limit: FCC 15.407: mobile and portable client device, RSS-247: OEM devices installed in vehicles

Tested Freq. [MHz]	Antenna			Conducted power				e.i.r.p.								
	RF0 [mW]	RF1 [mW]	Sum [mW]	Result [dBm]	FCC 15.407 Limit [dBm]	Margin [dB]	RSS-247 Limit [dBm]	Margin [dB]	RF0 [mW]	RF1 [mW]	Sum [mW]	Result [dBm]	FCC 15.407 Limit [dBm]	Margin [dB]	RSS-247 Limit [dBm]	Margin [dB]
5180	2.43	2.91	5.34	7.27	23.97	16.70	-	-	7.67	9.20	16.88	12.27	29.97	17.70	14.34	2.07
5220	2.51	2.90	5.41	7.33	23.97	16.64	-	-	7.94	9.16	17.11	12.33	29.97	17.64	14.34	2.01
5240	2.39	2.75	5.15	7.12	23.97	16.85	-	-	7.57	8.71	16.28	12.12	29.97	17.85	14.34	2.22
5745	2.59	3.00	5.59	7.47	30.00	22.53	30.00	22.53	8.18	9.48	17.67	12.47	36.00	23.53	36.00	23.53
5785	2.54	2.77	5.31	7.25	30.00	22.75	30.00	22.75	8.04	8.77	16.81	12.25	36.00	23.75	36.00	23.75
5825	2.33	2.75	5.08	7.06	30.00	22.94	30.00	22.94	7.36	8.71	16.07	12.06	36.00	23.94	36.00	23.94

Tested Freq. [MHz]	RF0							RF1						
	Reading [dBm]	Cable Loss [dB]	Atten. Loss [dB]	Antenna Gain [dBi]	Cond. Power [dBm]	e.i.r.p. [dBm]	Result [dBm]	Reading [dBm]	Cable Loss [dB]	Atten. Loss [dB]	Antenna Gain [dBi]	Cond. Power [dBm]	e.i.r.p. [dBm]	Result [dBm]
5180	-	-10.38	4.29	9.94	5.00	3.85	8.85	-9.36	4.28	9.72	5.00	4.64	9.64	9.64
5220	-	-10.23	4.29	9.94	5.00	4.00	9.00	-9.39	4.29	9.72	5.00	4.62	9.62	9.62
5240	-	-10.46	4.31	9.94	5.00	3.79	8.79	-9.62	4.30	9.72	5.00	4.40	9.40	9.40
5745	-	-10.36	4.54	9.95	5.00	4.13	9.13	-9.51	4.54	9.74	5.00	4.77	9.77	9.77
5785	-	-10.46	4.56	9.95	5.00	4.05	9.05	-9.87	4.56	9.74	5.00	4.43	9.43	9.43
5825	-	-10.87	4.59	9.95	5.00	3.67	8.67	-9.93	4.59	9.74	5.00	4.40	9.40	9.40

Sample Calculation:

Conducted Power Result = Reading + Cable Loss (including the cable(s) customer supplied) + Atten. Loss
e.i.r.p. Result = Conducted Power Result + Antenna Gain

15.407 Limit

Conducted Power Limit (5150 MHz-5250 MHz) = 250 mW
Conducted Power Limit (5725 MHz-5850 MHz) = 1 W

RSS-247 Limit

Conducted Power Limit (5725 MHz-5850 MHz) = 1 W
e.i.r.p. Limit (5150 MHz-5250 MHz) = 30 mW or (1.76 + 10logB) dBm, whichever is lower
For all test frequencies, B was applied the minimum value (18.148 MHz) as conservative limit.

Although the EUT operates on Master mode, more stringent limit for Client device was applied. (U-NII-1 for FCC)
The test was performed with Gate function.

Maximum Conducted Output Power

Test place	Shonan EMC Lab.
Mode	Tx 11ax-20(OFDM), TPC Function: Off

Date	Test Place	Temperature	Humidity	Engineer
December 5, 2024	No.8 Shielded room	24 deg.C	38 %RH	Makoto Hosaka

11ax-20(OFDM)
RF0 + RF1

Applied limit: FCC 15.407: mobile and portable client device, RSS-247: OEM devices installed in vehicles

Tested Freq. [MHz]	Antenna			Conducted power				e.i.r.p.								
	RF0 [mW]	RF1 [mW]	Sum [mW]	Result [dBm]	FCC 15.407 Limit [dBm]	Margin [dB]	RSS-247 Limit [dBm]	Margin [dB]	RF0 [mW]	RF1 [mW]	Sum [mW]	Result [dBm]	FCC 15.407 Limit [dBm]	Margin [dB]	RSS-247 Limit [dBm]	Margin [dB]
5180	2.56	2.90	5.46	7.37	23.97	16.60	-	-	8.09	9.18	17.27	12.37	29.97	17.60	14.59	2.22
5220	2.60	2.95	5.55	7.44	23.97	16.53	-	-	8.22	9.33	17.55	12.44	29.97	17.53	14.59	2.15
5240	2.53	2.90	5.43	7.35	23.97	16.62	-	-	8.00	9.18	17.18	12.35	29.97	17.62	14.59	2.24
5745	2.74	3.09	5.83	7.65	30.00	22.35	30.00	22.35	8.65	9.77	18.42	12.65	36.00	23.35	36.00	23.35
5785	2.70	2.83	5.53	7.43	30.00	22.57	30.00	22.57	8.53	8.95	17.48	12.43	36.00	23.57	36.00	23.57
5825	2.45	2.84	5.29	7.24	30.00	22.76	30.00	22.76	7.76	8.97	16.74	12.24	36.00	23.76	36.00	23.76

Tested Freq. [MHz]	RF0							RF1						
	Reading [dBm]	Cable Loss [dB]	Atten. Loss [dB]	Antenna Gain [dBi]	Result Cond. Power [dBm]	e.i.r.p. [dBm]	Reading [dBm]	Cable Loss [dB]	Atten. Loss [dB]	Antenna Gain [dBi]	Result Cond. Power [dBm]	e.i.r.p. [dBm]		
5180	-	-10.15	4.29	9.94	5.00	4.08	9.08	-9.37	4.28	9.72	5.00	4.63	9.63	
5220	-	-10.08	4.29	9.94	5.00	4.15	9.15	-9.31	4.29	9.72	5.00	4.70	9.70	
5240	-	-10.22	4.31	9.94	5.00	4.03	9.03	-9.39	4.30	9.72	5.00	4.63	9.63	
5745	-	-10.12	4.54	9.95	5.00	4.37	9.37	-9.38	4.54	9.74	5.00	4.90	9.90	
5785	-	-10.20	4.56	9.95	5.00	4.31	9.31	-9.78	4.56	9.74	5.00	4.52	9.52	
5825	-	-10.64	4.59	9.95	5.00	3.90	8.90	-9.80	4.59	9.74	5.00	4.53	9.53	

Sample Calculation:

Conducted Power Result = Reading + Cable Loss (including the cable(s) customer supplied) + Atten. Loss
e.i.r.p. Result = Conducted Power Result + Antenna Gain

15.407 Limit

Conducted Power Limit (5150 MHz-5250 MHz) = 250 mW
Conducted Power Limit (5725 MHz-5850 MHz) = 1 W

RSS-247 Limit

Conducted Power Limit (5725 MHz-5850 MHz) = 1 W
e.i.r.p. Limit (5150 MHz-5250 MHz) = 30 mW or (1.76 + 10logB) dBm, whichever is lower
For all test frequencies, B was applied the minimum value (19.213 MHz) as conservative limit.

Although the EUT operates on Master mode, more stringent limit for Client device was applied. (U-NII-1 for FCC)
The test was performed with Gate function.

Maximum Conducted Output Power

Test place	Shonan EMC Lab.
Mode	Tx 11ax-20(OFDMA) 26-tone RU, TPC Function: Off

Date	Test Place	Temperature	Humidity	Engineer
December 5, 2024	No.8 Shielded room	24 deg.C	38 %RH	Makoto Hosaka

11ax-20(OFDMA), 26-tone RU
RF0 + RF1

Applied limit: FCC 15.407: mobile and portable client device, RSS-247: OEM devices installed in vehicles

Tested Freq. [MHz]	RU Index	Antenna			Conducted power			RSS-247		Antenna			Result		FCC 15.407		RSS-247	
		RF0 [mW]	RF1 [mW]	Sum [mW]	Result [dBm]	Limit [dBm]	Margin [dB]	Limit [dBm]	Margin [dB]	RF0 [mW]	RF1 [mW]	Sum [mW]	Result [dBm]	Limit [dBm]	Margin [dB]	Limit [dBm]	Margin [dB]	
5180	0	1.76	2.02	3.78	5.78	23.97	18.19	-	-	5.56	6.40	11.96	10.78	29.97	19.19	14.11	3.33	
	4	1.82	2.07	3.89	5.90	23.97	18.07	-	-	5.77	6.53	12.30	10.90	29.97	19.07	14.11	3.21	
	8	2.01	2.27	4.28	6.32	23.97	17.65	-	-	6.37	7.18	13.55	11.32	29.97	18.65	14.11	2.79	
5220	0	2.05	2.26	4.32	6.35	23.97	17.62	-	-	6.49	7.16	13.65	11.35	29.97	18.62	14.11	2.76	
	4	1.87	2.04	3.92	5.93	23.97	18.04	-	-	5.93	6.46	12.39	10.93	29.97	19.04	14.11	3.18	
	8	2.09	2.24	4.33	6.37	23.97	17.60	-	-	6.62	7.08	13.70	11.37	29.97	18.60	14.11	2.74	
5240	0	2.02	2.18	4.21	6.24	23.97	17.73	-	-	6.40	6.90	13.30	11.24	29.97	18.73	14.11	2.87	
	4	1.85	1.98	3.83	5.83	23.97	18.14	-	-	5.85	6.27	12.11	10.83	29.97	19.14	14.11	3.28	
	8	2.05	2.21	4.26	6.30	23.97	17.67	-	-	6.49	7.00	13.48	11.30	29.97	18.67	14.11	2.81	
5745	0	2.05	2.39	4.44	6.48	30.00	23.52	30.00	23.52	6.49	7.57	14.05	11.48	36.00	24.52	36.00	24.52	
	4	1.91	2.16	4.07	6.09	30.00	23.91	30.00	23.91	6.04	6.82	12.86	11.09	36.00	24.91	36.00	24.91	
	8	2.10	2.39	4.49	6.52	30.00	23.48	30.00	23.48	6.65	7.55	14.20	11.52	36.00	24.48	36.00	24.48	
5785	0	2.10	2.29	4.38	6.42	30.00	23.58	30.00	23.58	6.64	7.23	13.87	11.42	36.00	24.58	36.00	24.58	
	4	1.87	2.01	3.88	5.89	30.00	24.11	30.00	24.11	5.92	6.37	12.28	10.89	36.00	25.11	36.00	25.11	
	8	2.04	2.19	4.23	6.27	30.00	23.73	30.00	23.73	6.46	6.93	13.39	11.27	36.00	24.73	36.00	24.73	
5825	0	1.99	2.48	4.47	6.50	30.00	23.50	30.00	23.50	6.30	7.83	14.13	11.50	36.00	24.50	36.00	24.50	
	4	1.79	2.16	3.95	5.97	30.00	24.03	30.00	24.03	5.68	6.82	12.50	10.97	36.00	25.03	36.00	25.03	
	8	1.96	2.34	4.30	6.34	30.00	23.66	30.00	23.66	6.19	7.41	13.61	11.34	36.00	24.66	36.00	24.66	

Tested Freq. [MHz]	RU Index	RF0							RF1						
		Reading [dBm]	Cable Loss [dB]	Atten. Loss [dB]	Antenna Gain [dBi]	Cond. Power [dBm]	e.i.r.p. [dBm]	Reading [dBm]	Cable Loss [dB]	Atten. Loss [dB]	Antenna Gain [dBi]	Cond. Power [dBm]	e.i.r.p. [dBm]		
5180	0	-	-11.78	4.29	9.94	5.00	2.45	7.45	-10.94	4.28	9.72	5.00	3.06	8.06	
	4	-	-11.62	4.29	9.94	5.00	2.61	7.61	-10.85	4.28	9.72	5.00	3.15	8.15	
	8	-	-11.19	4.29	9.94	5.00	3.04	8.04	-10.44	4.28	9.72	5.00	3.56	8.56	
5220	0	-	-11.11	4.29	9.94	5.00	3.12	8.12	-10.46	4.29	9.72	5.00	3.55	8.55	
	4	-	-11.50	4.29	9.94	5.00	2.73	7.73	-10.91	4.29	9.72	5.00	3.10	8.10	
	8	-	-11.02	4.29	9.94	5.00	3.21	8.21	-10.51	4.29	9.72	5.00	3.50	8.50	
5240	0	-	-11.19	4.31	9.94	5.00	3.06	8.06	-10.63	4.30	9.72	5.00	3.39	8.39	
	4	-	-11.58	4.31	9.94	5.00	2.67	7.67	-11.05	4.30	9.72	5.00	2.97	7.97	
	8	-	-11.13	4.31	9.94	5.00	3.12	8.12	-10.57	4.30	9.72	5.00	3.45	8.45	
5745	0	-	-11.37	4.54	9.95	5.00	3.12	8.12	-10.49	4.54	9.74	5.00	3.79	8.79	
	4	-	-11.68	4.54	9.95	5.00	2.81	7.81	-10.94	4.54	9.74	5.00	3.34	8.34	
	8	-	-11.26	4.54	9.95	5.00	3.23	8.23	-10.50	4.54	9.74	5.00	3.78	8.78	
5785	0	-	-11.29	4.56	9.95	5.00	3.22	8.22	-10.71	4.56	9.74	5.00	3.59	8.59	
	4	-	-11.79	4.56	9.95	5.00	2.72	7.72	-11.26	4.56	9.74	5.00	3.04	8.04	
	8	-	-11.41	4.56	9.95	5.00	3.10	8.10	-10.89	4.56	9.74	5.00	3.41	8.41	
5825	0	-	-11.55	4.59	9.95	5.00	2.99	7.99	-10.39	4.59	9.74	5.00	3.94	8.94	
	4	-	-12.00	4.59	9.95	5.00	2.54	7.54	-10.99	4.59	9.74	5.00	3.34	8.34	
	8	-	-11.62	4.59	9.95	5.00	2.92	7.92	-10.63	4.59	9.74	5.00	3.70	8.70	

Sample Calculation:

Conducted Power Result = Reading + Cable Loss (including the cable(s) customer supplied) + Atten. Loss
e.i.r.p. Result = Conducted Power Result + Antenna Gain

15.407 Limit

Conducted Power Limit (5150 MHz-5250 MHz) = 250 mW
Conducted Power Limit (5725 MHz-5850 MHz) = 1 W

RSS-247 Limit

Conducted Power Limit (5725 MHz-5850 MHz) = 1 W
e.i.r.p. Limit (5150 MHz-5250 MHz) = 30 mW or (1.76 + 10logB) dBm, whichever is lower
For all test frequencies, B was applied the minimum value (17.206 MHz) as conservative limit.

Although the EUT operates on Master mode, more stringent limit for Client device was applied. (U-NII-1 for FCC)
The test was performed with Gate function.

Maximum Conducted Output Power

Test place	Shonan EMC Lab.
Mode	Tx 11ax-20(OFDMA) 52-tone RU, TPC Function: Off

Date	Test Place	Temperature	Humidity	Engineer
December 5, 2024	No.8 Shielded room	24 deg.C	38 %RH	Makoto Hosaka

11ax-20(OFDMA), 52-tone RU
RF0 + RF1

Applied limit: FCC 15.407: mobile and portable client device, RSS-247: OEM devices installed in vehicles

Tested Freq. [MHz]	RU Index	Antenna			Conducted power			e.i.r.p.		Antenna			Result		FCC 15.407		RSS-247	
		RF0 [mW]	RF1 [mW]	Sum [mW]	Result [dBm]	FCC 15.407 Limit [dBm]	Margin [dB]	Limit [dBm]	Margin [dB]	RF0 [mW]	RF1 [mW]	Sum [mW]	[dBm]	Limit [dBm]	Margin [dB]	Limit [dBm]	Margin [dB]	
5180	37	2.62	2.99	5.61	7.49	23.97	16.48	-	-	8.28	9.46	17.74	12.49	29.97	17.48	14.12	1.63	
	38	2.64	2.80	5.44	7.35	23.97	16.62	-	-	8.34	8.85	17.19	12.35	29.97	17.62	14.12	1.77	
	40	2.75	2.90	5.66	7.53	23.97	16.44	-	-	8.71	9.18	17.89	12.53	29.97	17.44	14.12	1.59	
5220	37	2.90	2.98	5.88	7.69	23.97	16.28	-	-	9.16	9.42	18.58	12.69	29.97	17.28	14.12	1.43	
	38	2.75	2.81	5.57	7.46	23.97	16.51	-	-	8.71	8.89	17.60	12.46	29.97	17.51	14.12	1.66	
	40	2.94	2.96	5.90	7.71	23.97	16.26	-	-	9.31	9.35	18.67	12.71	29.97	17.26	14.12	1.41	
5240	37	2.81	2.82	5.63	7.51	23.97	16.46	-	-	8.87	8.93	17.80	12.51	29.97	17.46	14.12	1.61	
	38	2.65	2.67	5.32	7.26	23.97	16.71	-	-	8.39	8.43	16.83	12.26	29.97	17.71	14.12	1.86	
	40	2.81	2.83	5.64	7.51	23.97	16.46	-	-	8.87	8.95	17.83	12.51	29.97	17.46	14.12	1.61	
5745	37	2.82	3.20	6.02	7.79	30.00	22.21	30.00	22.21	8.91	10.12	19.03	12.79	36.00	23.21	36.00	23.21	
	38	2.65	3.00	5.65	7.52	30.00	22.48	30.00	22.48	8.39	9.48	17.88	12.52	36.00	23.48	36.00	23.48	
	40	2.76	3.11	5.87	7.69	30.00	22.31	30.00	22.31	8.73	9.84	18.57	12.69	36.00	23.31	36.00	23.31	
5785	37	2.67	2.97	5.64	7.52	30.00	22.48	30.00	22.48	8.45	9.40	17.85	12.52	36.00	23.48	36.00	23.48	
	38	2.59	2.81	5.40	7.32	30.00	22.68	30.00	22.68	8.20	8.87	17.08	12.32	36.00	23.68	36.00	23.68	
	40	2.61	2.87	5.48	7.39	30.00	22.61	30.00	22.61	8.24	9.08	17.32	12.39	36.00	23.61	36.00	23.61	
5825	37	2.61	3.22	5.83	7.65	30.00	22.35	30.00	22.35	8.24	10.19	18.43	12.65	36.00	23.35	36.00	23.35	
	38	2.45	3.03	5.48	7.38	30.00	22.62	30.00	22.62	7.74	9.57	17.32	12.38	36.00	23.62	36.00	23.62	
	40	2.52	3.09	5.61	7.49	30.00	22.51	30.00	22.51	7.96	9.77	17.73	12.49	36.00	23.51	36.00	23.51	

Tested Freq. [MHz]	RU Index	RF0							RF1						
		-	Reading [dBm]	Cable Loss [dB]	Atten. Loss [dB]	Antenna Gain [dBi]	Cond. Power [dBm]	e.i.r.p. [dBm]	Reading [dBm]	Cable Loss [dB]	Atten. Loss [dB]	Antenna Gain [dBi]	Cond. Power [dBm]	e.i.r.p. [dBm]	
5180	37	-	-10.05	4.29	9.94	5.00	4.18	9.18	-9.24	4.28	9.72	5.00	4.76	9.76	
	38	-	-10.02	4.29	9.94	5.00	4.21	9.21	-9.53	4.28	9.72	5.00	4.47	9.47	
	40	-	-9.83	4.29	9.94	5.00	4.40	9.40	-9.37	4.28	9.72	5.00	4.63	9.63	
5220	37	-	-9.61	4.29	9.94	5.00	4.62	9.62	-9.27	4.29	9.72	5.00	4.74	9.74	
	38	-	-9.83	4.29	9.94	5.00	4.40	9.40	-9.52	4.29	9.72	5.00	4.49	9.49	
	40	-	-9.54	4.29	9.94	5.00	4.69	9.69	-9.30	4.29	9.72	5.00	4.71	9.71	
5240	37	-	-9.77	4.31	9.94	5.00	4.48	9.48	-9.51	4.30	9.72	5.00	4.51	9.51	
	38	-	-10.01	4.31	9.94	5.00	4.24	9.24	-9.76	4.30	9.72	5.00	4.26	9.26	
	40	-	-9.77	4.31	9.94	5.00	4.48	9.48	-9.50	4.30	9.72	5.00	4.52	9.52	
5745	37	-	-9.99	4.54	9.95	5.00	4.50	9.50	-9.23	4.54	9.74	5.00	5.05	10.05	
	38	-	-10.25	4.54	9.95	5.00	4.24	9.24	-9.51	4.54	9.74	5.00	4.77	9.77	
	40	-	-10.08	4.54	9.95	5.00	4.41	9.41	-9.35	4.54	9.74	5.00	4.93	9.93	
5785	37	-	-10.24	4.56	9.95	5.00	4.27	9.27	-9.57	4.56	9.74	5.00	4.73	9.73	
	38	-	-10.37	4.56	9.95	5.00	4.14	9.14	-9.82	4.56	9.74	5.00	4.48	9.48	
	40	-	-10.35	4.56	9.95	5.00	4.16	9.16	-9.72	4.56	9.74	5.00	4.58	9.58	
5825	37	-	-10.38	4.59	9.95	5.00	4.16	9.16	-9.25	4.59	9.74	5.00	5.08	10.08	
	38	-	-10.65	4.59	9.95	5.00	3.89	8.89	-9.52	4.59	9.74	5.00	4.81	9.81	
	40	-	-10.53	4.59	9.95	5.00	4.01	9.01	-9.43	4.59	9.74	5.00	4.90	9.90	

Sample Calculation:

Conducted Power Result = Reading + Cable Loss (including the cable(s) customer supplied) + Atten. Loss
e.i.r.p. Result = Conducted Power Result + Antenna Gain

15.407 Limit

Conducted Power Limit (5150 MHz-5250 MHz) = 250 mW
Conducted Power Limit (5725 MHz-5850 MHz) = 1 W

RSS-247 Limit

Conducted Power Limit (5725 MHz-5850 MHz) = 1 W
e.i.r.p. Limit (5150 MHz-5250 MHz) = 30 mW or (1.76 + 10logB) dBm, whichever is lower
For all test frequencies, B was applied the minimum value (17.236 MHz) as conservative limit.

Although the EUT operates on Master mode, more stringent limit for Client device was applied. (U-NII-1 for FCC)
The test was performed with Gate function.

Maximum Conducted Output Power

Test place	Shonan EMC Lab.
Mode	Tx 11ax-20(OFDMA) 106-tone RU, TPC Function: Off

Date	Test Place	Temperature	Humidity	Engineer
December 5, 2024	No.8 Shielded room	24 deg.C	38 %RH	Makoto Hosaka

11ax-20(OFDMA), 106-tone RU
RF0 + RF1

Applied limit: FCC 15.407: mobile and portable client device, RSS-247: OEM devices installed in vehicles

Tested Freq. [MHz]	RU Index	Antenna			Conducted power						e.i.r.p.						
		RF0 [mW]	RF1 [mW]	Sum [mW]	Result [dBm]	FCC 15.407 Limit [dBm]	Margin [dB]	RSS-247 Limit [dBm]	Margin [dB]	RF0 [mW]	RF1 [mW]	Sum [mW]	Result [dBm]	FCC 15.407 Limit [dBm]	Margin [dB]	RSS-247 Limit [dBm]	Margin [dB]
5180	53	2.48	2.82	5.30	7.24	23.97	16.73	-	-	7.83	8.93	16.77	12.24	29.97	17.73	14.38	2.14
	54	2.57	2.88	5.45	7.36	23.97	16.61	-	-	8.13	9.10	17.23	12.36	29.97	17.61	14.38	2.02
5220	53	2.58	2.84	5.41	7.34	23.97	16.63	-	-	8.15	8.97	17.12	12.34	29.97	17.63	14.38	2.04
	54	2.61	2.83	5.44	7.35	23.97	16.62	-	-	8.24	8.95	17.20	12.35	29.97	17.62	14.38	2.03
5240	53	2.57	2.73	5.30	7.24	23.97	16.73	-	-	8.13	8.63	16.76	12.24	29.97	17.73	14.38	2.14
	54	2.57	2.77	5.34	7.28	23.97	16.69	-	-	8.13	8.77	16.90	12.28	29.97	17.69	14.38	2.10
5745	53	2.74	3.11	5.85	7.67	30.00	22.33	30.00	22.33	8.65	9.84	18.49	12.67	36.00	23.33	36.00	23.33
	54	2.68	3.05	5.73	7.58	30.00	22.42	30.00	22.42	8.47	9.64	18.11	12.58	36.00	23.42	36.00	23.42
5785	53	2.62	2.90	5.52	7.42	30.00	22.58	30.00	22.58	8.28	9.18	17.46	12.42	36.00	23.58	36.00	23.58
	54	2.53	2.73	5.26	7.21	30.00	22.79	30.00	22.79	8.00	8.63	16.63	12.21	36.00	23.79	36.00	23.79
5825	53	2.49	3.11	5.60	7.48	30.00	22.52	30.00	22.52	7.87	9.84	17.71	12.48	36.00	23.52	36.00	23.52
	54	2.47	2.94	5.40	7.33	30.00	22.67	30.00	22.67	7.80	9.29	17.09	12.33	36.00	23.67	36.00	23.67

Tested Freq. [MHz]	RU Index	RF0							RF1						
		-	Reading [dBm]	Cable Loss [dB]	Atten. Loss [dB]	Antenna Gain [dBi]	Cond. Power [dBm]	e.i.r.p. [dBm]	Reading [dBm]	Cable Loss [dB]	Atten. Loss [dB]	Antenna Gain [dBi]	Cond. Power [dBm]	e.i.r.p. [dBm]	
5180	53	-	-10.29	4.29	9.94	5.00	3.94	8.94	-9.49	4.28	9.72	5.00	4.51	9.51	
	54	-	-10.13	4.29	9.94	5.00	4.10	9.10	-9.41	4.28	9.72	5.00	4.59	9.59	
5220	53	-	-10.12	4.29	9.94	5.00	4.11	9.11	-9.48	4.29	9.72	5.00	4.53	9.53	
	54	-	-10.07	4.29	9.94	5.00	4.16	9.16	-9.49	4.29	9.72	5.00	4.52	9.52	
5240	53	-	-10.15	4.31	9.94	5.00	4.10	9.10	-9.66	4.30	9.72	5.00	4.36	9.36	
	54	-	-10.15	4.31	9.94	5.00	4.10	9.10	-9.59	4.30	9.72	5.00	4.43	9.43	
5745	53	-	-10.12	4.54	9.95	5.00	4.37	9.37	-9.35	4.54	9.74	5.00	4.93	9.93	
	54	-	-10.21	4.54	9.95	5.00	4.28	9.28	-9.44	4.54	9.74	5.00	4.84	9.84	
5785	53	-	-10.33	4.56	9.95	5.00	4.18	9.18	-9.67	4.56	9.74	5.00	4.63	9.63	
	54	-	-10.48	4.56	9.95	5.00	4.03	9.03	-9.94	4.56	9.74	5.00	4.36	9.36	
5825	53	-	-10.58	4.59	9.95	5.00	3.96	8.96	-9.40	4.59	9.74	5.00	4.93	9.93	
	54	-	-10.62	4.59	9.95	5.00	3.92	8.92	-9.65	4.59	9.74	5.00	4.68	9.68	

Sample Calculation:

Conducted Power Result = Reading + Cable Loss (including the cable(s) customer supplied) + Atten. Loss
e.i.r.p. Result = Conducted Power Result + Antenna Gain

15.407 Limit

Conducted Power Limit (5150 MHz-5250 MHz) = 250 mW
Conducted Power Limit (5725 MHz-5850 MHz) = 1 W

RSS-247 Limit

Conducted Power Limit (5725 MHz-5850 MHz) = 1 W
e.i.r.p. Limit (5150 MHz-5250 MHz) = 30 mW or (1.76 + 10logB) dBm, whichever is lower
For all test frequencies, B was applied the minimum value (18.296 MHz) as conservative limit.

Although the EUT operates on Master mode, more stringent limit for Client device was applied. (U-NII-1 for FCC)
The test was performed with Gate function.

Maximum Conducted Output Power

Test place	Shonan EMC Lab.
Mode	Tx 11ax-20(OFDMA) 242-tone RU, TPC Function: Off

Date	Test Place	Temperature	Humidity	Engineer
December 5, 2024	No.8 Shielded room	24 deg.C	38 %RH	Makoto Hosaka

11ax-20(OFDMA), 242-tone RU
RF0 + RF1

Applied limit: FCC 15.407: mobile and portable client device, RSS-247: OEM devices installed in vehicles

Tested Freq. [MHz]	RU Index	Antenna			Conducted power			RSS-247		Antenna			e.i.r.p.				
		RF0 [mW]	RF1 [mW]	Sum [mW]	Result [dBm]	FCC 15.407 Limit [dBm]	Margin [dB]	Limit [dBm]	Margin [dB]	RF0 [mW]	RF1 [mW]	Sum [mW]	Result [dBm]	FCC 15.407 Limit [dBm]	Margin [dB]	Limit [dBm]	Margin [dB]
5180	61	2.58	2.92	5.50	7.40	23.97	16.57	-	-	8.15	9.25	17.39	12.40	29.97	17.57	14.59	2.19
5220	61	2.69	2.91	5.60	7.48	23.97	16.49	-	-	8.51	9.20	17.72	12.48	29.97	17.49	14.59	2.11
5240	61	2.67	2.86	5.53	7.43	23.97	16.54	-	-	8.45	9.04	17.49	12.43	29.97	17.54	14.59	2.16
5745	61	2.74	3.14	5.88	7.69	30.00	22.31	30.00	22.31	8.65	9.93	18.58	12.69	36.00	23.31	36.00	23.31
5785	61	2.65	2.86	5.51	7.41	30.00	22.59	30.00	22.59	8.38	9.04	17.41	12.41	36.00	23.59	36.00	23.59
5825	61	2.55	3.16	5.71	7.57	30.00	22.43	30.00	22.43	8.05	10.00	18.05	12.57	36.00	23.43	36.00	23.43

Tested Freq. [MHz]	RU Index	RF0							RF1						
		Reading [dBm]	Cable Loss [dB]	Atten. Loss [dB]	Antenna Gain [dBi]	Cond. Power [dBm]	e.i.r.p. [dBm]	Reading [dBm]	Cable Loss [dB]	Atten. Loss [dB]	Antenna Gain [dBi]	Cond. Power [dBm]	e.i.r.p. [dBm]		
5180	61	-	-10.12	4.29	9.94	5.00	4.11	9.11	-9.34	4.28	9.72	5.00	4.66	9.66	
5220	61	-	-9.93	4.29	9.94	5.00	4.30	9.30	-9.37	4.29	9.72	5.00	4.64	9.64	
5240	61	-	-9.98	4.31	9.94	5.00	4.27	9.27	-9.46	4.30	9.72	5.00	4.56	9.56	
5745	61	-	-10.12	4.54	9.95	5.00	4.37	9.37	-9.31	4.54	9.74	5.00	4.97	9.97	
5785	61	-	-10.28	4.56	9.95	5.00	4.23	9.23	-9.74	4.56	9.74	5.00	4.56	9.56	
5825	61	-	-10.48	4.59	9.95	5.00	4.06	9.06	-9.33	4.59	9.74	5.00	5.00	10.00	

Sample Calculation:

Conducted Power Result = Reading + Cable Loss (including the cable(s) customer supplied) + Atten. Loss
e.i.r.p. Result = Conducted Power Result + Antenna Gain

15.407 Limit

Conducted Power Limit (5150 MHz-5250 MHz) = 250 mW
Conducted Power Limit (5725 MHz-5850 MHz) = 1 W

RSS-247 Limit

Conducted Power Limit (5725 MHz-5850 MHz) = 1 W
e.i.r.p. Limit (5150 MHz-5250 MHz) = 30 mW or (1.76 + 10logB) dBm, whichever is lower
For all test frequencies, B was applied the minimum value (19.203 MHz) as conservative limit.

Although the EUT operates on Master mode, more stringent limit for Client device was applied. (U-NII-1 for FCC)
The test was performed with Gate function.

Maximum Conducted Output Power

Test place	Shonan EMC Lab.
Mode	Tx 11n-40, TPC Function: Off

Date	Test Place	Temperature	Humidity	Engineer
December 5, 2024	No.8 Shielded room	24 deg.C	38 %RH	Makoto Hosaka

11n-40

RF0 + RF1

Applied limit: FCC 15.407: mobile and portable client device, RSS-247: OEM devices installed in vehicles

Tested Freq. [MHz]	Antenna			Conducted power				e.i.r.p.								
	RF0 [mW]	RF1 [mW]	Sum [mW]	Result [dBm]	FCC 15.407 Limit [dBm]	Margin [dB]	RSS-247 Limit [dBm]	Margin [dB]	RF0 [mW]	RF1 [mW]	Sum [mW]	Result [dBm]	FCC 15.407 Limit [dBm]	Margin [dB]	RSS-247 Limit [dBm]	Margin [dB]
5190	2.17	2.58	4.75	6.77	23.97	17.20	-	-	6.87	8.15	15.02	11.77	29.97	18.20	14.77	3.00
5230	2.22	2.48	4.70	6.72	23.97	17.25	-	-	7.01	7.85	14.87	11.72	29.97	18.25	14.77	3.05
5755	2.37	2.62	4.99	6.98	30.00	23.02	30.00	23.02	7.48	8.30	15.78	11.98	36.00	24.02	36.00	24.02
5795	3.08	2.78	5.86	7.68	30.00	22.32	30.00	22.32	9.73	8.79	18.52	12.68	36.00	23.32	36.00	23.32

Tested Freq. [MHz]	RF0					RF1							
	Reading [dBm]	Cable Loss [dB]	Atten. Loss [dB]	Antenna Gain [dBi]	Result e.i.r.p. [dBm]	Reading [dBm]	Cable Loss [dB]	Atten. Loss [dB]	Antenna Gain [dBi]	Result e.i.r.p. [dBm]			
5190	-	-10.86	4.29	9.94	5.00	3.37	8.37	-9.89	4.28	9.72	5.00	4.11	9.11
5230	-	-10.79	4.31	9.94	5.00	3.46	8.46	-10.07	4.30	9.72	5.00	3.95	8.95
5755	-	-10.75	4.54	9.95	5.00	3.74	8.74	-10.09	4.54	9.74	5.00	4.19	9.19
5795	-	-9.65	4.58	9.95	5.00	4.88	9.88	-9.88	4.58	9.74	5.00	4.44	9.44

Sample Calculation:

Conducted Power Result = Reading + Cable Loss (including the cable(s) customer supplied) + Atten. Loss

e.i.r.p. Result = Conducted Power Result + Antenna Gain

15.407 Limit

Conducted Power Limit (5150 MHz-5250 MHz) = 250 mW

Conducted Power Limit (5725 MHz-5850 MHz) = 1 W

RSS-247 Limit

Conducted Power Limit (5725 MHz-5850 MHz) = 1 W

e.i.r.p. Limit (5150 MHz-5250 MHz) = 30 mW or (1.76 + 10logB) dBm, whichever is lower

For all test frequencies, B was applied the minimum value (36.817 MHz) as conservative limit.

Although the EUT operates on Master mode, more stringent limit for Client device was applied. (U-NII-1 for FCC)

The test was performed with Gate function.

Maximum Conducted Output Power

Test place	Shonan EMC Lab.
Mode	Tx 11ac-40, TPC Function: Off

Date	Test Place	Temperature	Humidity	Engineer
December 5, 2024	No.8 Shielded room	24 deg.C	38 %RH	Makoto Hosaka

11ac-40

RF0 + RF1

Applied limit: FCC 15.407: mobile and portable client device, RSS-247: OEM devices installed in vehicles

Tested Freq. [MHz]	Antenna			Conducted power				e.i.r.p.								
	RF0 [mW]	RF1 [mW]	Sum [mW]	Result [dBm]	FCC 15.407 Limit [dBm]	Margin [dB]	RSS-247 Limit [dBm]	Margin [dB]	RF0 [mW]	RF1 [mW]	Sum [mW]	Result [dBm]	FCC 15.407 Limit [dBm]	Margin [dB]	RSS-247 Limit [dBm]	Margin [dB]
5190	2.19	2.60	4.79	6.80	23.97	17.17	-	-	6.92	8.22	15.14	11.80	29.97	18.17	14.77	2.97
5230	2.26	2.56	4.82	6.83	23.97	17.14	-	-	7.14	8.09	15.24	11.83	29.97	18.14	14.77	2.94
5755	2.45	2.67	5.12	7.09	30.00	22.91	30.00	22.91	7.74	8.45	16.20	12.09	36.00	23.91	36.00	23.91
5795	2.83	2.64	5.47	7.38	30.00	22.62	30.00	22.62	8.95	8.36	17.31	12.38	36.00	23.62	36.00	23.62

Tested Freq. [MHz]	RF0					RF1							
	Reading [dBm]	Cable Loss [dB]	Atten. Loss [dB]	Antenna Gain [dBi]	Result e.i.r.p. [dBm]	Reading [dBm]	Cable Loss [dB]	Atten. Loss [dB]	Antenna Gain [dBi]	Result e.i.r.p. [dBm]			
5190	-	-10.83	4.29	9.94	5.00	3.40	8.40	-9.85	4.28	9.72	5.00	4.15	9.15
5230	-	-10.71	4.31	9.94	5.00	3.54	8.54	-9.94	4.30	9.72	5.00	4.08	9.08
5755	-	-10.60	4.54	9.95	5.00	3.89	8.89	-10.01	4.54	9.74	5.00	4.27	9.27
5795	-	-10.01	4.58	9.95	5.00	4.52	9.52	-10.10	4.58	9.74	5.00	4.22	9.22

Sample Calculation:

Conducted Power Result = Reading + Cable Loss (including the cable(s) customer supplied) + Atten. Loss
e.i.r.p. Result = Conducted Power Result + Antenna Gain

15.407 Limit

Conducted Power Limit (5150 MHz-5250 MHz) = 250 mW
Conducted Power Limit (5725 MHz-5850 MHz) = 1 W

RSS-247 Limit

Conducted Power Limit (5725 MHz-5850 MHz) = 1 W
e.i.r.p. Limit (5150 MHz-5250 MHz) = 30 mW or (1.76 + 10logB) dBm, whichever is lower
For all test frequencies, B was applied the minimum value (37.002 MHz) as conservative limit.

Although the EUT operates on Master mode, more stringent limit for Client device was applied. (U-NII-1 for FCC)
The test was performed with Gate function.

Maximum Conducted Output Power

Test place	Shonan EMC Lab.
Mode	Tx 11ax-40(OFDM), TPC Function: Off

Date	Test Place	Temperature	Humidity	Engineer
December 5, 2024	No.8 Shielded room	24 deg.C	38 %RH	Makoto Hosaka

11ax-40(OFDM)

RF0 + RF1

Applied limit: FCC 15.407: mobile and portable client device, RSS-247: OEM devices installed in vehicles

Tested Freq. [MHz]	Antenna			Conducted power				e.i.r.p.								
	RF0 [mW]	RF1 [mW]	Sum [mW]	Result [dBm]	FCC 15.407 Limit [dBm]	Margin [dB]	RSS-247 Limit [dBm]	Margin [dB]	RF0 [mW]	RF1 [mW]	Sum [mW]	Result [dBm]	FCC 15.407 Limit [dBm]	Margin [dB]	RSS-247 Limit [dBm]	Margin [dB]
5190	2.29	2.65	4.95	6.94	23.97	17.03	-	-	7.24	8.39	15.64	11.94	29.97	18.03	14.77	2.83
5230	2.30	2.62	4.91	6.91	23.97	17.06	-	-	7.26	8.28	15.54	11.91	29.97	18.06	14.77	2.86
5755	2.44	2.77	5.21	7.17	30.00	22.83	30.00	22.83	7.73	8.75	16.48	12.17	36.00	23.83	36.00	23.83
5795	3.13	2.85	5.98	7.77	30.00	22.23	30.00	22.23	9.91	9.02	18.92	12.77	36.00	23.23	36.00	23.23

Tested Freq. [MHz]	RF0					RF1							
	Reading [dBm]	Cable Loss [dB]	Atten. Loss [dB]	Antenna Gain [dBi]	Result e.i.r.p. [dBm]	Reading [dBm]	Cable Loss [dB]	Atten. Loss [dB]	Antenna Gain [dBi]	Result e.i.r.p. [dBm]			
5190	-	-10.63	4.29	9.94	5.00	3.60	8.60	-9.76	4.28	9.72	5.00	4.24	9.24
5230	-	-10.64	4.31	9.94	5.00	3.61	8.61	-9.84	4.30	9.72	5.00	4.18	9.18
5755	-	-10.61	4.54	9.95	5.00	3.88	8.88	-9.86	4.54	9.74	5.00	4.42	9.42
5795	-	-9.57	4.58	9.95	5.00	4.96	9.96	-9.77	4.58	9.74	5.00	4.55	9.55

Sample Calculation:

Conducted Power Result = Reading + Cable Loss (including the cable(s) customer supplied) + Atten. Loss
e.i.r.p. Result = Conducted Power Result + Antenna Gain

15.407 Limit

Conducted Power Limit (5150 MHz-5250 MHz) = 250 mW
Conducted Power Limit (5725 MHz-5850 MHz) = 1 W

RSS-247 Limit

Conducted Power Limit (5725 MHz-5850 MHz) = 1 W
e.i.r.p. Limit (5150 MHz-5250 MHz) = 30 mW or (1.76 + 10logB) dBm, whichever is lower
For all test frequencies, B was applied the minimum value (38.306 MHz) as conservative limit.

Although the EUT operates on Master mode, more stringent limit for Client device was applied. (U-NII-1 for FCC)
The test was performed with Gate function.

Maximum Conducted Output Power

Test place	Shonan EMC Lab.
Mode	Tx 11ax-40(OFDMA) 26-tone RU, TPC Function: Off

Date	Test Place	Temperature	Humidity	Engineer
December 5, 2024	No.8 Shielded room	24 deg.C	38 %RH	Makoto Hosaka

11ax-40(OFDMA), 26-tone RU
RF0 + RF1

Applied limit: FCC 15.407: mobile and portable client device, RSS-247: OEM devices installed in vehicles

Tested Freq. [MHz]	RU Index	Antenna			Conducted power			FCC 15.407		RSS-247		Antenna			Result		FCC 15.407		RSS-247	
		RF0 [mW]	RF1 [mW]	Sum [mW]	Result [dBm]	Limit [dBm]	Margin [dB]	Limit [dBm]	Margin [dB]	RF0 [mW]	RF1 [mW]	Sum [mW]	Result [dBm]	Limit [dBm]	Margin [dB]	Limit [dBm]	Margin [dB]			
5190	0	1.83	2.07	3.89	5.90	23.97	18.07	-	-	5.78	6.53	12.31	10.90	29.97	19.07	14.77	3.87			
	8	1.99	2.18	4.16	6.19	23.97	17.78	-	-	6.28	6.89	13.17	11.19	29.97	18.78	14.77	3.58			
	17	2.07	2.30	4.37	6.41	23.97	17.56	-	-	6.55	7.28	13.82	11.41	29.97	18.56	14.77	3.36			
5230	0	2.03	2.24	4.27	6.31	23.97	17.66	-	-	6.41	7.10	13.51	11.31	29.97	18.66	14.77	3.46			
	8	2.00	2.15	4.15	6.18	23.97	17.79	-	-	6.34	6.79	13.13	11.18	29.97	18.79	14.77	3.59			
	17	2.10	2.25	4.35	6.38	23.97	17.59	-	-	6.64	7.11	13.75	11.38	29.97	18.59	14.77	3.39			
5755	0	2.26	2.56	4.82	6.83	30.00	23.17	30.00	23.17	7.16	8.09	15.25	11.83	36.00	24.17	36.00	24.17			
	8	2.09	2.35	4.44	6.48	30.00	23.52	30.00	23.52	6.62	7.43	14.05	11.48	36.00	24.52	36.00	24.52			
	17	2.11	2.38	4.49	6.52	30.00	23.48	30.00	23.48	6.67	7.53	14.20	11.52	36.00	24.48	36.00	24.48			
5795	0	2.77	2.67	5.43	7.35	30.00	22.65	30.00	22.65	8.75	8.43	17.18	12.35	36.00	23.65	36.00	23.65			
	8	2.57	2.45	5.02	7.01	30.00	22.99	30.00	22.99	8.13	7.74	15.87	12.01	36.00	23.99	36.00	23.99			
	17	2.58	2.43	5.01	7.00	30.00	23.00	30.00	23.00	8.17	7.69	15.86	12.00	36.00	24.00	36.00	24.00			

Tested Freq. [MHz]	RU Index	RF0							RF1						
		-	Reading [dBm]	Cable Loss [dB]	Atten. Loss [dB]	Antenna Gain [dBi]	Cond. Power [dBm]	e.i.r.p. [dBm]	Reading [dBm]	Cable Loss [dB]	Atten. Loss [dB]	Antenna Gain [dBi]	Cond. Power [dBm]	e.i.r.p. [dBm]	
5190	0	-	-11.61	4.29	9.94	5.00	2.62	7.62	-10.85	4.28	9.72	5.00	3.15	8.15	
	8	-	-11.25	4.29	9.94	5.00	2.98	7.98	-10.62	4.28	9.72	5.00	3.38	8.38	
	17	-	-11.07	4.29	9.94	5.00	3.16	8.16	-10.38	4.28	9.72	5.00	3.62	8.62	
5230	0	-	-11.18	4.31	9.94	5.00	3.07	8.07	-10.51	4.30	9.72	5.00	3.51	8.51	
	8	-	-11.23	4.31	9.94	5.00	3.02	8.02	-10.70	4.30	9.72	5.00	3.32	8.32	
	17	-	-11.03	4.31	9.94	5.00	3.22	8.22	-10.50	4.30	9.72	5.00	3.52	8.52	
5755	0	-	-10.94	4.54	9.95	5.00	3.55	8.55	-10.20	4.54	9.74	5.00	4.08	9.08	
	8	-	-11.28	4.54	9.95	5.00	3.21	8.21	-10.57	4.54	9.74	5.00	3.71	8.71	
	17	-	-11.25	4.54	9.95	5.00	3.24	8.24	-10.51	4.54	9.74	5.00	3.77	8.77	
5795	0	-	-10.11	4.58	9.95	5.00	4.42	9.42	-10.06	4.58	9.74	5.00	4.26	9.26	
	8	-	-10.43	4.58	9.95	5.00	4.10	9.10	-10.43	4.58	9.74	5.00	3.89	8.89	
	17	-	-10.41	4.58	9.95	5.00	4.12	9.12	-10.46	4.58	9.74	5.00	3.86	8.86	

Sample Calculation:

Conducted Power Result = Reading + Cable Loss (including the cable(s) customer supplied) + Atten. Loss

e.i.r.p. Result = Conducted Power Result + Antenna Gain

15.407 Limit

Conducted Power Limit (5150 MHz-5250 MHz) = 250 mW

Conducted Power Limit (5725 MHz-5850 MHz) = 1 W

RSS-247 Limit

Conducted Power Limit (5725 MHz-5850 MHz) = 1 W

e.i.r.p. Limit (5150 MHz-5250 MHz) = 30 mW or (1.76 + 10logB) dBm, whichever is lower

For all test frequencies, B was applied the minimum value (36.633 MHz) as conservative limit.

Although the EUT operates on Master mode, more stringent limit for Client device was applied. (U-NII-1 for FCC)
The test was performed with Gate function.

Maximum Conducted Output Power

Test place	Shonan EMC Lab.
Mode	Tx 11ax-40(OFDMA) 52-tone RU, TPC Function: Off

Date	Test Place	Temperature	Humidity	Engineer
December 5, 2024	No.8 Shielded room	24 deg.C	38 %RH	Makoto Hosaka

11ax-40(OFDMA), 52-tone RU
RF0 + RF1

Applied limit: FCC 15.407: mobile and portable client device, RSS-247: OEM devices installed in vehicles

Tested Freq. [MHz]	RU Index	Antenna			Conducted power			FCC 15.407		RSS-247		Antenna			Result		FCC 15.407		RSS-247	
		RF0 [mW]	RF1 [mW]	Sum [mW]	Result [dBm]	Limit [dBm]	Margin [dB]	Limit [dBm]	Margin [dB]	RF0 [mW]	RF1 [mW]	Sum [mW]	Result [dBm]	Limit [dBm]	Margin [dB]	Limit [dBm]	Margin [dB]			
5190	37	2.10	2.36	4.45	6.49	23.97	17.48	-	-	6.64	7.45	14.08	11.49	29.97	18.48	14.77	3.28			
	40	2.23	2.44	4.67	6.69	23.97	17.28	-	-	7.05	7.71	14.76	11.69	29.97	18.28	14.77	3.08			
	44	2.32	2.58	4.90	6.90	23.97	17.07	-	-	7.35	8.15	15.49	11.90	29.97	18.07	14.77	2.87			
5230	37	2.30	2.54	4.84	6.85	23.97	17.12	-	-	7.28	8.04	15.31	11.85	29.97	18.12	14.77	2.92			
	40	2.24	2.40	4.65	6.67	23.97	17.30	-	-	7.10	7.60	14.70	11.67	29.97	18.30	14.77	3.10			
	44	2.37	2.52	4.89	6.89	23.97	17.08	-	-	7.50	7.96	15.46	11.89	29.97	18.08	14.77	2.88			
5755	37	2.47	2.79	5.26	7.21	30.00	22.79	30.00	22.79	7.80	8.83	16.63	12.21	36.00	23.79	36.00	23.79			
	40	2.36	2.66	5.02	7.01	30.00	22.99	30.00	22.99	7.46	8.41	15.88	12.01	36.00	23.99	36.00	23.99			
	44	2.38	2.69	5.07	7.05	30.00	22.95	30.00	22.95	7.53	8.51	16.04	12.05	36.00	23.95	36.00	23.95			
5795	37	3.08	2.96	6.04	7.81	30.00	22.19	30.00	22.19	9.75	9.35	19.10	12.81	36.00	23.19	36.00	23.19			
	40	2.88	2.74	5.62	7.50	30.00	22.50	30.00	22.50	9.10	8.67	17.77	12.50	36.00	23.50	36.00	23.50			
	44	2.90	2.74	5.64	7.51	30.00	22.49	30.00	22.49	9.16	8.67	17.83	12.51	36.00	23.49	36.00	23.49			

Tested Freq. [MHz]	RU Index	RF0							RF1						
		-	Reading [dBm]	Cable Loss [dB]	Atten. Loss [dB]	Antenna Gain [dBi]	Cond. Power [dBm]	e.i.r.p. [dBm]	Reading [dBm]	Cable Loss [dB]	Atten. Loss [dB]	Antenna Gain [dBi]	Cond. Power [dBm]	e.i.r.p. [dBm]	
5190	37	-	-11.01	4.29	9.94	5.00	3.22	8.22	-10.28	4.28	9.72	5.00	3.72	8.72	
	40	-	-10.75	4.29	9.94	5.00	3.48	8.48	-10.13	4.28	9.72	5.00	3.87	8.87	
	44	-	-10.57	4.29	9.94	5.00	3.66	8.66	-9.89	4.28	9.72	5.00	4.11	9.11	
5230	37	-	-10.63	4.31	9.94	5.00	3.62	8.62	-9.97	4.30	9.72	5.00	4.05	9.05	
	40	-	-10.74	4.31	9.94	5.00	3.51	8.51	-10.21	4.30	9.72	5.00	3.81	8.81	
	44	-	-10.50	4.31	9.94	5.00	3.75	8.75	-10.01	4.30	9.72	5.00	4.01	9.01	
5755	37	-	-10.57	4.54	9.95	5.00	3.92	8.92	-9.82	4.54	9.74	5.00	4.46	9.46	
	40	-	-10.76	4.54	9.95	5.00	3.73	8.73	-10.03	4.54	9.74	5.00	4.25	9.25	
	44	-	-10.72	4.54	9.95	5.00	3.77	8.77	-9.98	4.54	9.74	5.00	4.30	9.30	
5795	37	-	-9.64	4.58	9.95	5.00	4.89	9.89	-9.61	4.58	9.74	5.00	4.71	9.71	
	40	-	-9.94	4.58	9.95	5.00	4.59	9.59	-9.94	4.58	9.74	5.00	4.38	9.38	
	44	-	-9.91	4.58	9.95	5.00	4.62	9.62	-9.94	4.58	9.74	5.00	4.38	9.38	

Sample Calculation:

Conducted Power Result = Reading + Cable Loss (including the cable(s) customer supplied) + Atten. Loss

e.i.r.p. Result = Conducted Power Result + Antenna Gain

15.407 Limit

Conducted Power Limit (5150 MHz-5250 MHz) = 250 mW

Conducted Power Limit (5725 MHz-5850 MHz) = 1 W

RSS-247 Limit

Conducted Power Limit (5725 MHz-5850 MHz) = 1 W

e.i.r.p. Limit (5150 MHz-5250 MHz) = 30 mW or (1.76 + 10logB) dBm, whichever is lower

For all test frequencies, B was applied the minimum value (36.737 MHz) as conservative limit.

Although the EUT operates on Master mode, more stringent limit for Client device was applied. (U-NII-1 for FCC)

The test was performed with Gate function.

Maximum Conducted Output Power

Test place	Shonan EMC Lab.
Mode	Tx 11ax-40(OFDMA) 106-tone RU, TPC Function: Off

Date	Test Place	Temperature	Humidity	Engineer
December 5, 2024	No.8 Shielded room	24 deg.C	38 %RH	Makoto Hosaka

11ax-40(OFDMA), 106-tone RU
RF0 + RF1

Applied limit: FCC 15.407: mobile and portable client device, RSS-247: OEM devices installed in vehicles

Tested Freq. [MHz]	RU Index	Antenna			Conducted power			e.i.r.p.			Antenna			Result			FCC 15.407			RSS-247			
		RF0 [mW]	RF1 [mW]	Sum [mW]	Result [dBm]	FCC 15.407 Limit [dBm]	Margin [dB]	Limit [dBm]	Margin [dB]	RF0 [mW]	RF1 [mW]	Sum [mW]	Result [dBm]	Limit [dBm]	Margin [dB]	Limit [dBm]	Margin [dB]	Limit [dBm]	Margin [dB]				
5190	53	2.12	2.37	4.49	6.52	23.97	17.45	-	-	6.70	7.50	14.20	11.52	29.97	18.45	14.77	3.25						
	54	2.30	2.55	4.85	6.86	23.97	17.11	-	-	7.28	8.07	15.35	11.86	29.97	18.11	14.77	2.91						
	56	2.42	2.70	5.12	7.09	23.97	16.88	-	-	7.66	8.53	16.19	12.09	29.97	17.88	14.77	2.68						
5230	53	2.33	2.58	4.91	6.91	23.97	17.06	-	-	7.38	8.15	15.53	11.91	29.97	18.06	14.77	2.86						
	54	2.32	2.49	4.81	6.82	23.97	17.15	-	-	7.35	7.87	15.22	11.82	29.97	18.15	14.77	2.95						
	56	2.43	2.58	5.00	6.99	23.97	16.98	-	-	7.67	8.15	15.82	11.99	29.97	17.98	14.77	2.78						
5755	53	2.51	2.87	5.38	7.31	30.00	22.69	30.00	22.69	7.94	9.08	17.02	12.31	36.00	23.69	36.00	23.69	36.00	23.69				
	54	2.40	2.70	5.10	7.08	30.00	22.92	30.00	22.92	7.59	8.55	16.14	12.08	36.00	23.92	36.00	23.92	36.00	23.92				
	56	2.44	2.77	5.21	7.17	30.00	22.83	30.00	22.83	7.73	8.75	16.48	12.17	36.00	23.83	36.00	23.83	36.00	23.83				
5795	53	3.15	3.02	6.17	7.90	30.00	22.10	30.00	22.10	9.95	9.55	19.50	12.90	36.00	23.10	36.00	23.10	36.00	23.10				
	54	3.01	2.86	5.87	7.69	30.00	22.31	30.00	22.31	9.51	9.06	18.56	12.69	36.00	23.31	36.00	23.31	36.00	23.31				
	56	3.01	2.77	5.78	7.62	30.00	22.38	30.00	22.38	9.53	8.75	18.28	12.62	36.00	23.38	36.00	23.38	36.00	23.38				

Tested Freq. [MHz]	RU Index	RF0							RF1						
		-	Reading [dBm]	Cable Loss [dB]	Atten. Loss [dB]	Antenna Gain [dBi]	Result Cond. Power [dBm]	e.i.r.p. [dBm]	Reading [dBm]	Cable Loss [dB]	Atten. Loss [dB]	Antenna Gain [dBi]	Result Cond. Power [dBm]	e.i.r.p. [dBm]	
5190	53	-	-10.97	4.29	9.94	5.00	3.26	8.26	-10.25	4.28	9.72	5.00	3.75	8.75	
	54	-	-10.61	4.29	9.94	5.00	3.62	8.62	-9.93	4.28	9.72	5.00	4.07	9.07	
	56	-	-10.39	4.29	9.94	5.00	3.84	8.84	-9.69	4.28	9.72	5.00	4.31	9.31	
5230	53	-	-10.57	4.31	9.94	5.00	3.68	8.68	-9.91	4.30	9.72	5.00	4.11	9.11	
	54	-	-10.59	4.31	9.94	5.00	3.66	8.66	-10.06	4.30	9.72	5.00	3.96	8.96	
	56	-	-10.40	4.31	9.94	5.00	3.85	8.85	-9.91	4.30	9.72	5.00	4.11	9.11	
5755	53	-	-10.49	4.54	9.95	5.00	4.00	9.00	-9.70	4.54	9.74	5.00	4.58	9.58	
	54	-	-10.69	4.54	9.95	5.00	3.80	8.80	-9.96	4.54	9.74	5.00	4.32	9.32	
	56	-	-10.61	4.54	9.95	5.00	3.88	8.88	-9.86	4.54	9.74	5.00	4.42	9.42	
5795	53	-	-9.55	4.58	9.95	5.00	4.98	9.98	-9.52	4.58	9.74	5.00	4.80	9.80	
	54	-	-9.75	4.58	9.95	5.00	4.78	9.78	-9.75	4.58	9.74	5.00	4.57	9.57	
	56	-	-9.74	4.58	9.95	5.00	4.79	9.79	-9.90	4.58	9.74	5.00	4.42	9.42	

Sample Calculation:

Conducted Power Result = Reading + Cable Loss (including the cable(s) customer supplied) + Atten. Loss

e.i.r.p. Result = Conducted Power Result + Antenna Gain

15.407 Limit

Conducted Power Limit (5150 MHz-5250 MHz) = 250 mW

Conducted Power Limit (5725 MHz-5850 MHz) = 1 W

RSS-247 Limit

Conducted Power Limit (5725 MHz-5850 MHz) = 1 W

e.i.r.p. Limit (5150 MHz-5250 MHz) = 30 mW or (1.76 + 10logB) dBm, whichever is lower

For all test frequencies, B was applied the minimum value (36.756 MHz) as conservative limit.

Although the EUT operates on Master mode, more stringent limit for Client device was applied. (U-NII-1 for FCC)
The test was performed with Gate function.

Maximum Conducted Output Power

Test place	Shonan EMC Lab.
Mode	Tx 11ax-40(OFDMA) 242-tone RU, TPC Function: Off

Date	Test Place	Temperature	Humidity	Engineer
December 5, 2024	No.8 Shielded room	24 deg.C	38 %RH	Makoto Hosaka

11ax-40(OFDMA), 242-tone RU

RF0 + RF1

Applied limit: FCC 15.407: mobile and portable client device, RSS-247: OEM devices installed in vehicles

Tested Freq. [MHz]	RU Index	Antenna			Conducted power						e.i.r.p.						
		RF0 [mW]	RF1 [mW]	Sum [mW]	Result [dBm]	FCC 15.407 Limit [dBm]	Margin [dB]	RSS-247 Limit [dBm]	Margin [dB]	RF0 [mW]	RF1 [mW]	Sum [mW]	Result [dBm]	FCC 15.407 Limit [dBm]	Margin [dB]	RSS-247 Limit [dBm]	Margin [dB]
5190	61	2.32	2.57	4.89	6.89	23.97	17.08	-	-	7.33	8.13	15.46	11.89	29.97	18.08	14.77	2.88
	62	2.34	2.58	4.93	6.93	23.97	17.04	-	-	7.41	8.17	15.58	11.93	29.97	18.04	14.77	2.84
5230	61	2.32	2.51	4.83	6.84	23.97	17.13	-	-	7.33	7.94	15.27	11.84	29.97	18.13	14.77	2.93
	62	2.38	2.53	4.91	6.91	23.97	17.06	-	-	7.53	8.00	15.53	11.91	29.97	18.06	14.77	2.86
5755	61	2.45	2.77	5.23	7.18	30.00	22.82	30.00	22.82	7.76	8.77	16.53	12.18	36.00	23.82	36.00	23.82
	62	2.42	2.74	5.16	7.12	30.00	22.88	30.00	22.88	7.66	8.65	16.31	12.12	36.00	23.88	36.00	23.88
5795	61	3.11	2.97	6.08	7.84	30.00	22.16	30.00	22.16	9.84	9.40	19.24	12.84	36.00	23.16	36.00	23.16
	62	3.00	2.81	5.81	7.64	30.00	22.36	30.00	22.36	9.48	8.89	18.38	12.64	36.00	23.36	36.00	23.36

Tested Freq. [MHz]	RU Index	RF0							RF1						
		Reading [dBm]	Cable Loss [dB]	Atten. Loss [dB]	Antenna Gain [dBi]	Result Cond. Power [dBm]	Result e.i.r.p. [dBm]	Reading [dBm]	Cable Loss [dB]	Atten. Loss [dB]	Antenna Gain [dBi]	Result Cond. Power [dBm]	Result e.i.r.p. [dBm]		
5190	61	-	-10.58	4.29	9.94	5.00	3.65	8.65	-9.90	4.28	9.72	5.00	4.10	9.10	
	62	-	-10.53	4.29	9.94	5.00	3.70	8.70	-9.88	4.28	9.72	5.00	4.12	9.12	
5230	61	-	-10.60	4.31	9.94	5.00	3.65	8.65	-10.02	4.30	9.72	5.00	4.00	9.00	
	62	-	-10.48	4.31	9.94	5.00	3.77	8.77	-9.99	4.30	9.72	5.00	4.03	9.03	
5755	61	-	-10.59	4.54	9.95	5.00	3.90	8.90	-9.85	4.54	9.74	5.00	4.43	9.43	
	62	-	-10.65	4.54	9.95	5.00	3.84	8.84	-9.91	4.54	9.74	5.00	4.37	9.37	
5795	61	-	-9.60	4.58	9.95	5.00	4.93	9.93	-9.59	4.58	9.74	5.00	4.73	9.73	
	62	-	-9.76	4.58	9.95	5.00	4.77	9.77	-9.83	4.58	9.74	5.00	4.49	9.49	

Sample Calculation:

Conducted Power Result = Reading + Cable Loss (including the cable(s) customer supplied) + Atten. Loss

e.i.r.p. Result = Conducted Power Result + Antenna Gain

15.407 Limit

Conducted Power Limit (5150 MHz-5250 MHz) = 250 mW

Conducted Power Limit (5725 MHz-5850 MHz) = 1 W

RSS-247 Limit

Conducted Power Limit (5725 MHz-5850 MHz) = 1 W

e.i.r.p. Limit (5150 MHz-5250 MHz) = 30 mW or (1.76 + 10logB) dBm, whichever is lower

For all test frequencies, B was applied the minimum value (37.409 MHz) as conservative limit.

Although the EUT operates on Master mode, more stringent limit for Client device was applied. (U-NII-1 for FCC)

The test was performed with Gate function.

Maximum Conducted Output Power

Test place	Shonan EMC Lab.
Mode	Tx 11ax-40(OFDMA) 484-tone RU, TPC Function: Off

Date	Test Place	Temperature	Humidity	Engineer
December 5, 2024	No.8 Shielded room	24 deg.C	38 %RH	Makoto Hosaka

11ax-40(OFDMA), 484-tone RU

RF0 + RF1

Applied limit: FCC 15.407: mobile and portable client device, RSS-247: OEM devices installed in vehicles

Tested Freq. [MHz]	RU Index	Antenna			Conducted power						e.i.r.p.						
		RF0 [mW]	RF1 [mW]	Sum [mW]	Result [dBm]	FCC 15.407 Limit [dBm]	Margin [dB]	RSS-247 Limit [dBm]	Margin [dB]	RF0 [mW]	RF1 [mW]	Sum [mW]	Result [dBm]	FCC 15.407 Limit [dBm]	Margin [dB]	RSS-247 Limit [dBm]	Margin [dB]
5190	65	2.33	2.58	4.91	6.91	23.97	17.06	-	-	7.38	8.15	15.53	11.91	29.97	18.06	14.77	2.86
5230	65	2.43	2.62	5.04	7.03	23.97	16.94	-	-	7.67	8.28	15.95	12.03	29.97	17.94	14.77	2.74
5755	65	2.49	2.81	5.29	7.24	30.00	22.76	30.00	22.76	7.87	8.87	16.74	12.24	36.00	23.76	36.00	23.76
5795	65	2.99	2.86	5.84	7.67	30.00	22.33	30.00	22.33	9.44	9.04	18.48	12.67	36.00	23.33	36.00	23.33

Tested Freq. [MHz]	RU Index	-	RF0						RF1					
			Reading [dBm]	Cable Loss [dB]	Atten. Loss [dB]	Antenna Gain [dBi]	Cond. Power [dBm]	e.i.r.p. [dBm]	Reading [dBm]	Cable Loss [dB]	Atten. Loss [dB]	Antenna Gain [dBi]	Cond. Power [dBm]	e.i.r.p. [dBm]
5190	65	-	-10.55	4.29	9.94	5.00	3.68	8.68	-9.89	4.28	9.72	5.00	4.11	9.11
5230	65	-	-10.40	4.31	9.94	5.00	3.85	8.85	-9.84	4.30	9.72	5.00	4.18	9.18
5755	65	-	-10.53	4.54	9.95	5.00	3.96	8.96	-9.80	4.54	9.74	5.00	4.48	9.48
5795	65	-	-9.78	4.58	9.95	5.00	4.75	9.75	-9.76	4.58	9.74	5.00	4.56	9.56

Sample Calculation:

Conducted Power Result = Reading + Cable Loss (including the cable(s) customer supplied) + Atten. Loss

e.i.r.p. Result = Conducted Power Result + Antenna Gain

15.407 Limit

Conducted Power Limit (5150 MHz-5250 MHz) = 250 mW

Conducted Power Limit (5725 MHz-5850 MHz) = 1 W

RSS-247 Limit

Conducted Power Limit (5725 MHz-5850 MHz) = 1 W

e.i.r.p. Limit (5150 MHz-5250 MHz) = 30 mW or (1.76 + 10logB) dBm, whichever is lower

For all test frequencies, B was applied the minimum value (38.264 MHz) as conservative limit.

Although the EUT operates on Master mode, more stringent limit for Client device was applied. (U-NII-1 for FCC)
The test was performed with Gate function.

Maximum Conducted Output Power

Test place	Shonan EMC Lab.
Mode	Tx 11ac-80, TPC Function: Off

Date	Test Place	Temperature	Humidity	Engineer
December 5, 2024	No.8 Shielded room	24 deg.C	38 %RH	Makoto Hosaka

11ac-80

RF0 + RF1

Applied limit: FCC 15.407: mobile and portable client device, RSS-247: OEM devices installed in vehicles

Tested Freq. [MHz]	Antenna			Conducted power				e.i.r.p.								
	RF0 [mW]	RF1 [mW]	Sum [mW]	Result [dBm]	FCC 15.407 Limit [dBm]	Margin [dB]	RSS-247 Limit [dBm]	Margin [dB]	RF0 [mW]	RF1 [mW]	Sum [mW]	Result [dBm]	FCC 15.407 Limit [dBm]	Margin [dB]	RSS-247 Limit [dBm]	Margin [dB]
5210	1.98	2.23	4.21	6.24	23.97	17.73	-	-	6.27	7.05	13.31	11.24	29.97	18.73	14.77	3.53
5775	2.86	2.48	5.35	7.28	30.00	22.72	30.00	22.72	9.06	7.85	16.91	12.28	36.00	23.72	36.00	23.72

Tested Freq. [MHz]	RF0							RF1						
	Reading [dBm]	Cable Loss [dB]	Atten. Loss [dB]	Antenna Gain [dBi]	Cond. Power [dBm]	e.i.r.p. [dBm]	Result [dBm]	Reading [dBm]	Cable Loss [dB]	Atten. Loss [dB]	Antenna Gain [dBi]	Cond. Power [dBm]	e.i.r.p. [dBm]	Result [dBm]
5210	-	-11.26	4.29	9.94	5.00	2.97	7.97	-10.52	4.28	9.72	5.00	3.48	8.48	
5775	-	-9.95	4.57	9.95	5.00	4.57	9.57	-10.36	4.57	9.74	5.00	3.95	8.95	

Sample Calculation:

Conducted Power Result = Reading + Cable Loss (including the cable(s) customer supplied) + Atten. Loss
e.i.r.p. Result = Conducted Power Result + Antenna Gain

15.407 Limit

Conducted Power Limit (5150 MHz-5250 MHz) = 250 mW

Conducted Power Limit (5725 MHz-5850 MHz) = 1 W

RSS-247 Limit

Conducted Power Limit (5725 MHz-5850 MHz) = 1 W

e.i.r.p. Limit (5150 MHz-5250 MHz) = 30 mW or (1.76 + 10logB) dBm, whichever is lower

For all test frequencies, B was applied the minimum value (76.799 MHz) as conservative limit.

Although the EUT operates on Master mode, more stringent limit for Client device was applied. (U-NII-1 for FCC)
The test was performed with Gate function.

Maximum Conducted Output Power

Test place	Shonan EMC Lab.
Mode	Tx 11ax-80(OFDM), TPC Function: Off

Date	Test Place	Temperature	Humidity	Engineer
December 5, 2024	No.8 Shielded room	24 deg.C	38 %RH	Makoto Hosaka

11ax-80(OFDM)

RF0 + RF1

Applied limit: FCC 15.407: mobile and portable client device, RSS-247: OEM devices installed in vehicles

Tested Freq. [MHz]	Antenna			Conducted power				e.i.r.p.								
	RF0 [mW]	RF1 [mW]	Sum [mW]	Result [dBm]	FCC 15.407 Limit [dBm]	Margin [dB]	RSS-247 Limit [dBm]	Margin [dB]	RF0 [mW]	RF1 [mW]	Sum [mW]	Result [dBm]	FCC 15.407 Limit [dBm]	Margin [dB]	RSS-247 Limit [dBm]	Margin [dB]
5210	2.08	2.33	4.41	6.45	23.97	17.52	-	-	6.58	7.38	13.96	11.45	29.97	18.52	14.77	3.32
5775	2.81	2.43	5.23	7.19	30.00	22.81	30.00	22.81	8.87	7.67	16.55	12.19	36.00	23.81	36.00	23.81

Tested Freq. [MHz]	RF0						RF1						
	Reading [dBm]	Cable Loss [dB]	Atten. Loss [dB]	Antenna Gain [dBi]	Cond. Power [dBm]	e.i.r.p. [dBm]	Reading [dBm]	Cable Loss [dB]	Atten. Loss [dB]	Antenna Gain [dBi]	Cond. Power [dBm]	e.i.r.p. [dBm]	
5210	-	-11.05	4.29	9.94	5.00	3.18	8.18	-10.32	4.28	9.72	5.00	3.68	8.68
5775	-	-10.04	4.57	9.95	5.00	4.48	9.48	-10.46	4.57	9.74	5.00	3.85	8.85

Sample Calculation:

Conducted Power Result = Reading + Cable Loss (including the cable(s) customer supplied) + Atten. Loss
e.i.r.p. Result = Conducted Power Result + Antenna Gain

15.407 Limit

Conducted Power Limit (5150 MHz-5250 MHz) = 250 mW

Conducted Power Limit (5725 MHz-5850 MHz) = 1 W

RSS-247 Limit

Conducted Power Limit (5725 MHz-5850 MHz) = 1 W

e.i.r.p. Limit (5150 MHz-5250 MHz) = 30 mW or (1.76 + 10logB) dBm, whichever is lower

For all test frequencies, B was applied the minimum value (77.941 MHz) as conservative limit.

Although the EUT operates on Master mode, more stringent limit for Client device was applied. (U-NII-1 for FCC)

The test was performed with Gate function.

Maximum Conducted Output Power

Test place	Shonan EMC Lab.
Mode	Tx 11ax-80(OFDMA) 26-tone RU, TPC Function: Off

Date	Test Place	Temperature	Humidity	Engineer
December 8, 2024	No.8 Shielded room	21 deg.C	36 %RH	Shiro Kobayashi

11ax-80(OFDMA), 26-tone RU
RF0 + RF1

Applied limit: FCC 15.407: mobile and portable client device, RSS-247: OEM devices installed in vehicles

Tested Freq. [MHz]	RU Index	Antenna			Conducted power			FCC 15.407		RSS-247		Antenna			Result e.i.r.p.			FCC 15.407		RSS-247	
		RF0 [mW]	RF1 [mW]	Sum [mW]	Result [dBm]	Limit [dBm]	Margin [dB]	Limit [dBm]	Margin [dB]	RF0 [mW]	RF1 [mW]	Sum [mW]	Result [dBm]	Limit [dBm]	Margin [dB]	Limit [dBm]	Margin [dB]	Limit [dBm]	Margin [dB]		
5210	0	2.04	2.23	4.27	6.30	23.97	17.67	-	-	6.44	7.05	13.49	11.30	29.97	18.67	14.77	3.47				
	18	2.08	2.25	4.34	6.37	23.97	17.60	-	-	6.59	7.13	13.72	11.37	29.97	18.60	14.77	3.40				
	36	2.14	2.32	4.46	6.49	23.97	17.48	-	-	6.76	7.35	14.11	11.49	29.97	18.48	14.77	3.28				
5775	0	3.02	2.60	5.62	7.50	30.00	22.50	30.00	22.50	9.55	8.22	17.77	12.50	36.00	23.50	36.00	23.50				
	18	2.75	2.42	5.17	7.13	30.00	22.87	30.00	22.87	8.69	7.66	16.35	12.13	36.00	23.87	36.00	23.87				
	36	2.64	2.19	4.83	6.84	30.00	23.16	30.00	23.16	8.36	6.92	15.27	11.84	36.00	24.16	36.00	24.16				

Tested Freq. [MHz]	RU Index	RF0							RF1						
		-	Reading [dBm]	Cable Loss [dB]	Atten. Loss [dB]	Antenna Gain [dBi]	Cond. Power [dBm]	e.i.r.p. [dBm]	Reading [dBm]	Cable Loss [dB]	Atten. Loss [dB]	Antenna Gain [dBi]	Cond. Power [dBm]	e.i.r.p. [dBm]	
5210	0	-	-11.14	4.29	9.94	5.00	3.09	8.09	-10.52	4.28	9.72	5.00	3.48	8.48	
	18	-	-11.04	4.29	9.94	5.00	3.19	8.19	-10.47	4.28	9.72	5.00	3.53	8.53	
	36	-	-10.93	4.29	9.94	5.00	3.30	8.30	-10.34	4.28	9.72	5.00	3.66	8.66	
5775	0	-	-9.72	4.57	9.95	5.00	4.80	9.80	-10.16	4.57	9.74	5.00	4.15	9.15	
	18	-	-10.13	4.57	9.95	5.00	4.39	9.39	-10.47	4.57	9.74	5.00	3.84	8.84	
	36	-	-10.30	4.57	9.95	5.00	4.22	9.22	-10.91	4.57	9.74	5.00	3.40	8.40	

Sample Calculation:

Conducted Power Result = Reading + Cable Loss (including the cable(s) customer supplied) + Atten. Loss
e.i.r.p. Result = Conducted Power Result + Antenna Gain

15.407 Limit

Conducted Power Limit (5150 MHz-5250 MHz) = 250 mW
Conducted Power Limit (5725 MHz-5850 MHz) = 1 W

RSS-247 Limit

Conducted Power Limit (5725 MHz-5850 MHz) = 1 W
e.i.r.p. Limit (5150 MHz-5250 MHz) = 30 mW or (1.76 + 10logB) dBm, whichever is lower
For all test frequencies, B was applied the minimum value (74.929 MHz) as conservative limit.

Although the EUT operates on Master mode, more stringent limit for Client device was applied. (U-NII-1 for FCC)
The test was performed with Gate function.

Maximum Conducted Output Power

Test place	Shonan EMC Lab.
Mode	Tx 11ax-80(OFDMA) 52-tone RU, TPC Function: Off

Date	Test Place	Temperature	Humidity	Engineer
December 8, 2024	No.8 Shielded room	21 deg.C	36 %RH	Shiro Kobayashi

11ax-80(OFDMA), 52-tone RU
RF0 + RF1

Applied limit: FCC 15.407: mobile and portable client device, RSS-247: OEM devices installed in vehicles

Tested Freq. [MHz]	RU Index	Antenna			Conducted power			RSS-247		Antenna			Result		FCC 15.407		RSS-247	
		RF0 [mW]	RF1 [mW]	Sum [mW]	Result [dBm]	FCC 15.407 Limit [dBm]	Margin [dB]	Limit [dBm]	Margin [dB]	RF0 [mW]	RF1 [mW]	Sum [mW]	Result [dBm]	FCC 15.407 Limit [dBm]	Margin [dB]	Limit [dBm]	Margin [dB]	
5210	37	2.13	2.36	4.49	6.53	23.97	17.44	-	-	6.75	7.46	14.21	11.53	29.97	18.44	14.77	3.24	
	44	2.10	2.31	4.42	6.45	23.97	17.52	-	-	6.65	7.31	13.96	11.45	29.97	18.52	14.77	3.32	
	52	2.29	2.48	4.77	6.78	23.97	17.19	-	-	7.24	7.83	15.08	11.78	29.97	18.19	14.77	2.99	
5775	37	3.18	2.76	5.94	7.74	30.00	22.26	30.00	22.26	10.07	8.73	18.80	12.74	36.00	23.26	36.00	23.26	
	44	2.96	2.58	5.53	7.43	30.00	22.57	30.00	22.57	9.35	8.15	17.50	12.43	36.00	23.57	36.00	23.57	
	52	2.88	2.38	5.26	7.21	30.00	22.79	30.00	22.79	9.12	7.52	16.64	12.21	36.00	23.79	36.00	23.79	

Tested Freq. [MHz]	RU Index	RF0							RF1						
		-	Reading [dBm]	Cable Loss [dB]	Atten. Loss [dB]	Antenna Gain [dBi]	Cond. Power [dBm]	e.i.r.p. [dBm]	Reading [dBm]	Cable Loss [dB]	Atten. Loss [dB]	Antenna Gain [dBi]	Cond. Power [dBm]	e.i.r.p. [dBm]	
5210	37	-	-10.94	4.29	9.94	5.00	3.29	8.29	-10.27	4.28	9.72	5.00	3.73	8.73	
	44	-	-11.00	4.29	9.94	5.00	3.23	8.23	-10.36	4.28	9.72	5.00	3.64	8.64	
	52	-	-10.63	4.29	9.94	5.00	3.60	8.60	-10.06	4.28	9.72	5.00	3.94	8.94	
5775	37	-	-9.49	4.57	9.95	5.00	5.03	10.03	-9.90	4.57	9.74	5.00	4.41	9.41	
	44	-	-9.81	4.57	9.95	5.00	4.71	9.71	-10.20	4.57	9.74	5.00	4.11	9.11	
	52	-	-9.92	4.57	9.95	5.00	4.60	9.60	-10.55	4.57	9.74	5.00	3.76	8.76	

Sample Calculation:

Conducted Power Result = Reading + Cable Loss (including the cable(s) customer supplied) + Atten. Loss
e.i.r.p. Result = Conducted Power Result + Antenna Gain

15.407 Limit

Conducted Power Limit (5150 MHz-5250 MHz) = 250 mW
Conducted Power Limit (5725 MHz-5850 MHz) = 1 W

RSS-247 Limit

Conducted Power Limit (5725 MHz-5850 MHz) = 1 W
e.i.r.p. Limit (5150 MHz-5250 MHz) = 30 mW or (1.76 + 10logB) dBm, whichever is lower
For all test frequencies, B was applied the minimum value (75.230 MHz) as conservative limit.

Although the EUT operates on Master mode, more stringent limit for Client device was applied. (U-NII-1 for FCC)
The test was performed with Gate function.

Maximum Conducted Output Power

Test place	Shonan EMC Lab.
Mode	Tx 11ax-80(OFDMA) 106-tone RU, TPC Function: Off

Date	Test Place	Temperature	Humidity	Engineer
December 8, 2024	No.8 Shielded room	21 deg.C	36 %RH	Shiro Kobayashi

11ax-80(OFDMA), 106-tone RU
RF0 + RF1

Applied limit: FCC 15.407: mobile and portable client device, RSS-247: OEM devices installed in vehicles

Tested Freq. [MHz]	RU Index	Antenna			Conducted power			RSS-247		Antenna			Result		FCC 15.407		RSS-247	
		RF0 [mW]	RF1 [mW]	Sum [mW]	Result [dBm]	Limit [dBm]	Margin [dB]	Limit [dBm]	Margin [dB]	RF0 [mW]	RF1 [mW]	Sum [mW]	Result [dBm]	Limit [dBm]	Margin [dB]	Limit [dBm]	Margin [dB]	
5210	53	2.02	2.31	4.33	6.36	23.97	17.61	-	-	6.40	7.29	13.69	11.36	29.97	18.61	14.77	3.41	
	56	2.06	2.23	4.29	6.32	23.97	17.65	-	-	6.50	7.06	13.56	11.32	29.97	18.65	14.77	3.45	
	60	2.22	2.38	4.60	6.62	23.97	17.35	-	-	7.01	7.52	14.53	11.62	29.97	18.35	14.77	3.15	
5210	53	3.00	2.63	5.63	7.50	30.00	22.50	30.00	22.50	9.48	8.32	17.80	12.50	36.00	23.50	36.00	23.50	
	56	2.85	2.52	5.37	7.30	30.00	22.70	30.00	22.70	9.02	7.96	16.98	12.30	36.00	23.70	36.00	23.70	
	60	2.76	2.33	5.09	7.07	30.00	22.93	30.00	22.93	8.73	7.36	16.09	12.07	36.00	23.93	36.00	23.93	

Tested Freq. [MHz]	RU Index	RF0							RF1						
		-	Reading [dBm]	Cable Loss [dB]	Atten. Loss [dB]	Antenna Gain [dBi]	Cond. Power [dBm]	e.i.r.p. [dBm]	Reading [dBm]	Cable Loss [dB]	Atten. Loss [dB]	Antenna Gain [dBi]	Cond. Power [dBm]	e.i.r.p. [dBm]	
5210	53	-	-11.17	4.29	9.94	5.00	3.06	8.06	-10.37	4.28	9.72	5.00	3.63	8.63	
	56	-	-11.10	4.29	9.94	5.00	3.13	8.13	-10.51	4.28	9.72	5.00	3.49	8.49	
	60	-	-10.77	4.29	9.94	5.00	3.46	8.46	-10.24	4.28	9.72	5.00	3.76	8.76	
5775	53	-	-9.75	4.57	9.95	5.00	4.77	9.77	-10.11	4.57	9.74	5.00	4.20	9.20	
	56	-	-9.97	4.57	9.95	5.00	4.55	9.55	-10.30	4.57	9.74	5.00	4.01	9.01	
	60	-	-10.11	4.57	9.95	5.00	4.41	9.41	-10.64	4.57	9.74	5.00	3.67	8.67	

Sample Calculation:

Conducted Power Result = Reading + Cable Loss (including the cable(s) customer supplied) + Atten. Loss
e.i.r.p. Result = Conducted Power Result + Antenna Gain

15.407 Limit

Conducted Power Limit (5150 MHz-5250 MHz) = 250 mW
Conducted Power Limit (5725 MHz-5850 MHz) = 1 W

RSS-247 Limit

Conducted Power Limit (5725 MHz-5850 MHz) = 1 W
e.i.r.p. Limit (5150 MHz-5250 MHz) = 30 mW or (1.76 + 10logB) dBm, whichever is lower
For all test frequencies, B was applied the minimum value (75.351 MHz) as conservative limit.

Although the EUT operates on Master mode, more stringent limit for Client device was applied. (U-NII-1 for FCC)
The test was performed with Gate function.

Maximum Conducted Output Power

Test place	Shonan EMC Lab.
Mode	Tx 11ax-80(OFDMA) 242-tone RU, TPC Function: Off

Date	Test Place	Temperature	Humidity	Engineer
December 8, 2024	No.8 Shielded room	21 deg.C	36 %RH	Shiro Kobayashi

11ax-80(OFDMA), 242-tone RU
RF0 + RF1

Applied limit: FCC 15.407: mobile and portable client device, RSS-247: OEM devices installed in vehicles

Tested Freq. [MHz]	RU Index	Antenna			Conducted power			RSS-247		Antenna			e.i.r.p.				
		RF0 [mW]	RF1 [mW]	Sum [mW]	Result [dBm]	FCC 15.407 Limit [dBm]	Margin [dB]	Limit [dBm]	Margin [dB]	RF0 [mW]	RF1 [mW]	Sum [mW]	Result [dBm]	FCC 15.407 Limit [dBm]	Margin [dB]	Limit [dBm]	Margin [dB]
5210	61	2.05	2.33	4.37	6.41	23.97	17.56	-	-	6.47	7.36	13.83	11.41	29.97	18.56	14.77	3.36
	62	2.10	2.32	4.42	6.46	23.97	17.51	-	-	6.65	7.33	13.98	11.46	29.97	18.51	14.77	3.31
	64	2.19	2.36	4.55	6.58	23.97	17.39	-	-	6.93	7.45	14.38	11.58	29.97	18.39	14.77	3.19
5775	61	3.00	2.52	5.52	7.42	30.00	22.58	30.00	22.58	9.48	7.96	17.45	12.42	36.00	23.58	36.00	23.58
	62	3.02	2.59	5.61	7.49	30.00	22.51	30.00	22.51	9.55	8.18	17.73	12.49	36.00	23.51	36.00	23.51
	64	2.86	2.40	5.26	7.21	30.00	22.79	30.00	22.79	9.04	7.59	16.62	12.21	36.00	23.79	36.00	23.79

Tested Freq. [MHz]	RU Index	RF0							RF1						
		-	Reading [dBm]	Cable Loss [dB]	Atten. Loss [dB]	Antenna Gain [dBi]	Cond. Power [dBm]	e.i.r.p. [dBm]	Reading [dBm]	Cable Loss [dB]	Atten. Loss [dB]	Antenna Gain [dBi]	Cond. Power [dBm]	e.i.r.p. [dBm]	
5210	61	-	-11.12	4.29	9.94	5.00	3.11	8.11	-10.33	4.28	9.72	5.00	3.67	8.67	
	62	-	-11.00	4.29	9.94	5.00	3.23	8.23	-10.35	4.28	9.72	5.00	3.65	8.65	
	64	-	-10.82	4.29	9.94	5.00	3.41	8.41	-10.28	4.28	9.72	5.00	3.72	8.72	
5775	61	-	-9.75	4.57	9.95	5.00	4.77	9.77	-10.30	4.57	9.74	5.00	4.01	9.01	
	62	-	-9.72	4.57	9.95	5.00	4.80	9.80	-10.18	4.57	9.74	5.00	4.13	9.13	
	64	-	-9.96	4.57	9.95	5.00	4.56	9.56	-10.51	4.57	9.74	5.00	3.80	8.80	

Sample Calculation:

Conducted Power Result = Reading + Cable Loss (including the cable(s) customer supplied) + Atten. Loss

e.i.r.p. Result = Conducted Power Result + Antenna Gain

15.407 Limit

Conducted Power Limit (5150 MHz-5250 MHz) = 250 mW

Conducted Power Limit (5725 MHz-5850 MHz) = 1 W

RSS-247 Limit

Conducted Power Limit (5725 MHz-5850 MHz) = 1 W

e.i.r.p. Limit (5150 MHz-5250 MHz) = 30 mW or (1.76 + 10logB) dBm, whichever is lower

For all test frequencies, B was applied the minimum value (75.466 MHz) as conservative limit.

Although the EUT operates on Master mode, more stringent limit for Client device was applied. (U-NII-1 for FCC)
The test was performed with Gate function.

Maximum Conducted Output Power

Test place	Shonan EMC Lab.
Mode	Tx 11ax-80(OFDMA) 484-tone RU, TPC Function: Off

Date	Test Place	Temperature	Humidity	Engineer
December 8, 2024	No.8 Shielded room	21 deg.C	36 %RH	Shiro Kobayashi

11ax-80(OFDMA), 484-tone RU

RF0 + RF1

Applied limit: FCC 15.407: mobile and portable client device, RSS-247: OEM devices installed in vehicles

Tested Freq. [MHz]	RU Index	Antenna			Conducted power						e.i.r.p.						
		RF0 [mW]	RF1 [mW]	Sum [mW]	Result [dBm]	FCC 15.407 Limit [dBm]	Margin [dB]	RSS-247 Limit [dBm]	Margin [dB]	RF0 [mW]	RF1 [mW]	Sum [mW]	Result [dBm]	FCC 15.407 Limit [dBm]	Margin [dB]	RSS-247 Limit [dBm]	Margin [dB]
5210	65	2.23	2.46	4.69	6.71	23.97	17.26	-	-	7.05	7.78	14.83	11.71	29.97	18.26	14.77	3.06
	66	2.31	2.49	4.80	6.81	23.97	17.16	-	-	7.29	7.89	15.18	11.81	29.97	18.16	14.77	2.96
5775	65	2.98	2.59	5.57	7.46	30.00	22.54	30.00	22.54	9.42	8.18	17.60	12.46	36.00	23.54	36.00	23.54
	66	2.64	2.34	4.99	6.98	30.00	23.02	30.00	23.02	8.36	7.41	15.77	11.98	36.00	24.02	36.00	24.02

Tested Freq. [MHz]	RU Index	-	RF0						RF1					
			Reading [dBm]	Cable Loss [dB]	Atten. Loss [dB]	Antenna Gain [dBi]	Cond. Power [dBm]	e.i.r.p. [dBm]	Reading [dBm]	Cable Loss [dB]	Atten. Loss [dB]	Antenna Gain [dBi]	Cond. Power [dBm]	e.i.r.p. [dBm]
5210	65	-	-10.75	4.29	9.94	5.00	3.48	8.48	-10.09	4.28	9.72	5.00	3.91	8.91
	66	-	-10.60	4.29	9.94	5.00	3.63	8.63	-10.03	4.28	9.72	5.00	3.97	8.97
5775	65	-	-9.78	4.57	9.95	5.00	4.74	9.74	-10.18	4.57	9.74	5.00	4.13	9.13
	66	-	-10.30	4.57	9.95	5.00	4.22	9.22	-10.61	4.57	9.74	5.00	3.70	8.70

Sample Calculation:

Conducted Power Result = Reading + Cable Loss (including the cable(s) customer supplied) + Atten. Loss

e.i.r.p. Result = Conducted Power Result + Antenna Gain

15.407 Limit

Conducted Power Limit (5150 MHz-5250 MHz) = 250 mW

Conducted Power Limit (5725 MHz-5850 MHz) = 1 W

RSS-247 Limit

Conducted Power Limit (5725 MHz-5850 MHz) = 1 W

e.i.r.p. Limit (5150 MHz-5250 MHz) = 30 mW or (1.76 + 10logB) dBm, whichever is lower

For all test frequencies, B was applied the minimum value (77.220 MHz) as conservative limit.

Although the EUT operates on Master mode, more stringent limit for Client device was applied. (U-NII-1 for FCC)

The test was performed with Gate function.

Maximum Conducted Output Power

Test place	Shonan EMC Lab.
Mode	Tx 11ax-80(OFDMA) 996-tone RU, TPC Function: Off

Date	Test Place	Temperature	Humidity	Engineer
December 8, 2024	No.8 Shielded room	21 deg.C	36 %RH	Shiro Kobayashi

11ax-80(OFDMA), 996-tone RU

RF0 + RF1

Applied limit: FCC 15.407: mobile and portable client device, RSS-247: OEM devices installed in vehicles

Tested Freq. [MHz]	RU Index	Antenna			Conducted power						e.i.r.p.						
		RF0 [mW]	RF1 [mW]	Sum [mW]	Result [dBm]	FCC 15.407 Limit [dBm]	Margin [dB]	RSS-247 Limit [dBm]	Margin [dB]	RF0 [mW]	RF1 [mW]	Sum [mW]	Result [dBm]	FCC 15.407 Limit [dBm]	Margin [dB]	RSS-247 Limit [dBm]	Margin [dB]
5210	67	2.14	2.55	4.68	6.71	23.97	17.26	-	-	6.76	8.05	14.81	11.71	29.97	18.26	14.77	3.06
5775	67	3.03	2.68	5.71	7.56	30.00	22.44	30.00	22.44	9.57	8.47	18.04	12.56	36.00	23.44	36.00	23.44

Tested Freq. [MHz]	RU Index	RF0							RF1						
		Reading [dBm]	Cable Loss [dB]	Atten. Loss [dB]	Antenna Gain [dBi]	Cond. Power [dBm]	e.i.r.p. [dBm]	Reading [dBm]	Cable Loss [dB]	Atten. Loss [dB]	Antenna Gain [dBi]	Cond. Power [dBm]	e.i.r.p. [dBm]		
5210	67	-	-10.93	4.29	9.94	5.00	3.30	8.30	-9.94	4.28	9.72	5.00	4.06	9.06	
5775	67	-	-9.71	4.57	9.95	5.00	4.81	9.81	-10.03	4.57	9.74	5.00	4.28	9.28	

Sample Calculation:

Conducted Power Result = Reading + Cable Loss (including the cable(s) customer supplied) + Atten. Loss
e.i.r.p. Result = Conducted Power Result + Antenna Gain

15.407 Limit

Conducted Power Limit (5150 MHz-5250 MHz) = 250 mW

Conducted Power Limit (5725 MHz-5850 MHz) = 1 W

RSS-247 Limit

Conducted Power Limit (5725 MHz-5850 MHz) = 1 W

e.i.r.p. Limit (5150 MHz-5250 MHz) = 30 mW or (1.76 + 10logB) dBm, whichever is lower

For all test frequencies, B was applied the minimum value (77.925 MHz) as conservative limit.

Although the EUT operates on Master mode, more stringent limit for Client device was applied. (U-NII-1 for FCC)

The test was performed with Gate function.

APPENDIX 2: Test Instruments

Test Equipment

Test Item	LIMS ID	Description	Manufacturer	Model	Serial	Last Calibration Date	Cal Int
AT	145132	Attenuator	Weinschel Corp.	54A-10	W5692	2024/10/10	12
AT	160494	Attenuator	Weinschel Corp.	54A-10	83420	2023/12/12	12
AT	196949	Coaxial Cable	Huber+Suhner	SUCOFLEX 102	803480/2	2024/03/07	12
AT	235697	Coaxial Cable	Hayashi-Repic co., Ltd.	KMS020B-GL140sE- KMS020B-2.0m	47456-01-01	2024/04/09	12
AT	145113	Digital Multimeter	Agilent Technologies	U1251A	TW46350095	2024/09/24	12
AT	146247	Power Meter	Keysight Technologies Inc	8990B	MY51000272	2024/05/14	12
AT	146310	Power sensor	Keysight Technologies Inc	N1923A	MY5326009	2024/05/14	12
AT	146311	Power sensor	Keysight Technologies Inc	N1923A	MY5349008	2024/05/14	12
AT	191847	Thermo-Hygrometer	CUSTOM. Inc	CTH-201	-	2024/08/12	12

***Hyphens for Last Calibration Date and Cal Int (month) are instruments that Calibration is not required (e.g. software), or instruments checked in advance before use.**

The expiration date of the calibration is the end of the expired month.

As for some calibrations performed after the tested dates, those test equipment have been controlled by means of an unbroken chains of calibrations.

All equipment is calibrated with valid calibrations. Each measurement data is traceable to the national or international standards.

Test item:

AT: Antenna Terminal Conducted test