





RADIO TEST REPORT

Test Report No. 14747914S-C

Customer	Panasonic Automotive Systems Co., Ltd.
Description of EUT	Car Navigation
Model Number of EUT	AT2403
FCC ID	ACJ932AT2403
Test Regulation	FCC Part 15 Subpart E
Test Result	Complied
Issue Date	October 25, 2024
Remarks	WLAN (5 GHz band) part Antenna Terminal Conducted Tests

Representative Test Engineer	Approved By
	
Shiro Kobayashi Engineer	Shinichi Takano Engineer
	 
CERTIFICATE 1266.03	
<input type="checkbox"/> The testing in which "Non-accreditation" is displayed is outside the accreditation scopes in UL Japan, Inc.	
<input checked="" type="checkbox"/> There is no testing item of "Non-accreditation".	

Report Cover Page - Form-ULID-003532 (DCS:13-EM-F0429) Issue# 23.0

ANNOUNCEMENT

- This test report shall not be reproduced in full or partial, without the written approval of UL Japan, Inc.
- The results in this report apply only to the sample tested. (Laboratory was not involved in sampling.)
- This sample tested is in compliance with the limits of the above regulation.
- The test results in this test report are traceable to the national or international standards.
- This test report must not be used by the customer to claim product certification, approval, or endorsement by the A2LA accreditation body.
- This test report covers Radio technical requirements.
It does not cover administrative issues such as Manual or non-Radio test related Requirements. (if applicable)
- The all test items in this test report are conducted by UL Japan, Inc. Shonan EMC Lab.
- The opinions and the interpretations to the result of the description in this report are outside scopes where UL Japan, Inc. has been accredited.
- The information provided by the customer for this report is identified in SECTION 1.
- The laboratory is not responsible for information provided by the customer which can impact the validity of the results.
- For test report(s) referred in this report, the latest version (including any revisions) is always referred.

REVISION HISTORY

Original Test Report No. 14747914S-C

Revision	Test Report No.	Date	Page Revised Contents
- (Original)	14747914S-C	October 25, 2024	-

Reference: Abbreviations (Including words undescribed in this report)

A2LA	The American Association for Laboratory Accreditation	IEC	International Electrotechnical Commission
AC	Alternating Current	IEEE	Institute of Electrical and Electronics Engineers
AFH	Adaptive Frequency Hopping	IF	Intermediate Frequency
AM	Amplitude Modulation	ILAC	International Laboratory Accreditation Conference
Amp, AMP	Amplifier	ISED	Innovation, Science and Economic Development Canada
ANSI	American National Standards Institute	ISO	International Organization for Standardization
Ant, ANT	Antenna	JAB	Japan Accreditation Board
AP	Access Point	LAN	Local Area Network
ASK	Amplitude Shift Keying	LIMS	Laboratory Information Management System
Atten., ATT	Attenuator	MCS	Modulation and Coding Scheme
AV	Average	MRA	Mutual Recognition Arrangement
BPSK	Binary Phase-Shift Keying	N/A	Not Applicable
BR	Bluetooth Basic Rate	NIST	National Institute of Standards and Technology
BT	Bluetooth	NS	No signal detect.
BT LE	Bluetooth Low Energy	NSA	Normalized Site Attenuation
BW	BandWidth	NVLAP	National Voluntary Laboratory Accreditation Program
Cal Int	Calibration Interval	OBW	Occupied Band Width
CCK	Complementary Code Keying	OFDM	Orthogonal Frequency Division Multiplexing
Ch., CH	Channel	OFDMA	Orthogonal Frequency Division Multiple Access
CISPR	Comite International Special des Perturbations Radioelectriques	P/M	Power meter
CW	Continuous Wave	PCB	Printed Circuit Board
DBPSK	Differential BPSK	PER	Packet Error Rate
DC	Direct Current	PHY	Physical Layer
D-factor	Distance factor	PK	Peak
DFS	Dynamic Frequency Selection	PN	Pseudo random Noise
DQPSK	Differential QPSK	PP	Preamble Puncturing
DSSS	Direct Sequence Spread Spectrum	PRBS	Pseudo-Random Bit Sequence
EDR	Enhanced Data Rate	PSD	Power Spectral Density
EIRP, e.i.r.p.	Equivalent Isotropically Radiated Power	QAM	Quadrature Amplitude Modulation
EMC	ElectroMagnetic Compatibility	QP	Quasi-Peak
EMI	ElectroMagnetic Interference	QPSK	Quadri-Phase Shift Keying
EN	European Norm	RBW	Resolution Band Width
ERP, e.r.p.	Effective Radiated Power	RDS	Radio Data System
EU	European Union	RE	Radio Equipment
EUT	Equipment Under Test	RF	Radio Frequency
Fac.	Factor	RMS	Root Mean Square
FCC	Federal Communications Commission	RSS	Radio Standards Specifications
FHSS	Frequency Hopping Spread Spectrum	Rx	Receiving
FM	Frequency Modulation	SA, S/A	Spectrum Analyzer
Freq.	Frequency	SG	Signal Generator
FSK	Frequency Shift Keying	SVSWR	Site-Voltage Standing Wave Ratio
GFSK	Gaussian Frequency-Shift Keying	TR	Test Receiver
GNSS	Global Navigation Satellite System	Tx	Transmitting
GPS	Global Positioning System	VBW	Video BandWidth
Hori.	Horizontal	Vert.	Vertical
ICES	Interference-Causing Equipment Standard	WLAN	Wireless LAN

CONTENTS	PAGE
SECTION 1: Customer Information	5
SECTION 2: Equipment Under Test (EUT)	5
SECTION 3: Test specification, Procedures & Results	7
SECTION 4: Operation of EUT during testing	9
SECTION 5: Antenna Terminal Conducted Tests	12
APPENDIX 1: Test Data	13
99 % Occupied Bandwidth.....	13
6 dB Bandwidth.....	55
Maximum Conducted Output Power	80
Maximum Power Spectral Density	120
Conducted Spurious Emission.....	209
APPENDIX 2: Test Instruments	210
APPENDIX 3: Photographs of Test Setup	211
Antenna Terminal Conducted Tests	211

SECTION 1: Customer Information

Company Name	Panasonic Automotive Systems Co., Ltd. *1)
Address	4261, Ikonobe-cho, Tsuzuki-ku, Yokohama-shi, Kanagawa-ken 224-8520, Japan
Telephone Number	+81-50-1802-5117
Contact Person	Daisuke Takahata

*1) The Grantee name in the FCC application is "Panasonic Corporation of North America".

The information provided by the customer is as follows;

- Customer, Description of EUT, Model Number of EUT, FCC ID on the cover and other relevant pages
- Operating/Test Mode(s) (Mode(s)) on all the relevant pages
- SECTION 1: Customer Information
- SECTION 2: Equipment Under Test (EUT) other than the Receipt Date and Test Date
- SECTION 4: Operation of EUT during testing

SECTION 2: Equipment Under Test (EUT)

2.1 Identification of EUT

Description	Car Navigation
Model Number	AT2403
Serial Number	Refer to SECTION 4.2
Condition	Production prototype (Not for Sale: This sample is equivalent to mass-produced items.)
Modification	No Modification by the test lab
Receipt Date	April 3, 2023
Test Date	April 5 to June 1, 2023

2.2 Product Description

General Specification

Rating	DC 13.2 V
Operating temperature	-30 deg. C to +65 deg. C

Radio Specification

This report contains data provided by the customer which can impact the validity of results. UL Japan, Inc. is only responsible for the validity of results after the integration of the data provided by the customer. The data provided by the customer is marked "a)" in the table below.

Bluetooth (BR / EDR / BT LE)

Equipment Type	Transceiver
Frequency of Operation	2402 MHz to 2480 MHz
Type of Modulation	FHSS, GFSK / $\pi/4$ -DQPSK, 8DPSK / GFSK
Antenna Gain ^{a)}	4.00 dBi

WLAN (IEEE802.11b/11g/11n-20/11ax-20)

Equipment Type	Transceiver
Frequency of Operation	2412 MHz to 2462 MHz
Type of Modulation	DSSS, OFDM OFDMA: (20 MHz band): 26/52/106/242-tone RU
Antenna Gain ^{a)}	4.00 dBi

WLAN (IEEE802.11a/11n-20/11ac-20/11ax-20/11n-40/11ac-40/11ax-40/11ac-80/11ax-80)

Equipment Type	Transceiver	
Frequency of Operation	20 MHz Band	5180 MHz to 5240 MHz 5745 MHz to 5825 MHz
	40 MHz Band	5190 MHz to 5230 MHz 5755 MHz to 5795 MHz
	80 MHz Band	5210 MHz, 5775 MHz
Type of Modulation	OFDM	
	OFDMA (IEEE802.11ax only)	(20 MHz band): 26/52/106/242-tone RU
		(40 MHz band): 26/52/106/242/484-tone RU
(80 MHz band): 26/52/106/242/484/996-tone RU		
Antenna Gain ^{a)}	RF0: 5.00 dBi, RF1: 5.00 dBi	

SECTION 3: Test specification, Procedures & Results

3.1 Test Specification

Test Specification	FCC Part 15 Subpart E The latest version on the first day of the testing period
Title	FCC 47 CFR Part 15 Radio Frequency Device Subpart E Unlicensed National Information Infrastructure Devices Section 15.407 General technical requirements

* Also the EUT complies with FCC Part 15 Subpart B.

3.2 Procedures and Results

Item	Test Procedure	Specification	Worst Margin	Results	Remarks
Conducted Emission	FCC: ANSI C63.10-2013	FCC: 15.407 (b) (9) / 15.207	-	N/A	*1)
	ISED: RSS-Gen 8.8	ISED: RSS-Gen 8.8			
26 dB Emission Bandwidth	FCC: KDB Publication Number 789033	FCC: 15.407 (a) (1) (2) (3)	See data	Complied	Conducted
	ISED: -	ISED: -			
Maximum Conducted Output Power	FCC: KDB Publication Number 789033	FCC: 15.407 (a) (1) (2) (3)		Complied	Conducted
	ISED: -	ISED: RSS-247 6.2			
Maximum Power Spectral Density	FCC: KDB Publication Number 789033	FCC : 15.407 (a) (1) (2) (3)		Complied	Conducted
	ISED: -	ISED: RSS-247 6.2			
Spurious Emission Restricted Band Edge	FCC: ANSI C63.10-2013 KDB Publication Number 789033	FCC: 15.407 (b), 15.205 and 15.209	See data	Complied	Conducted (below 30 MHz)
	ISED: -	ISED: RSS-247 6.2			
6 dB Emission Bandwidth	FCC: ANSI C63.10-2013	FCC: 15.407 (e)	See data	Complied	Conducted
	ISED: -	ISED: RSS-247 6.2			
Note: UL Japan, Inc.'s EMI Work Procedures: Work Instructions-ULID-003591 and Work Instructions-ULID-003593. * In case any questions arise about test procedure, ANSI C63.10: 2013 is also referred.					
*1) The test is not applicable since the EUT does not have AC Mains.					

FCC Part 15.31 (e)

The EUT provides stable voltage constantly to the RF Part regardless of input voltage. Instead of a new battery, DC power supply was used for the test. That does not affect the test result, therefore the EUT complies with the requirement.

FCC Part 15.203 Antenna requirement

It is impossible for end users to replace the antenna, because the antenna is mounted inside of the EUT. Therefore, the equipment complies with the antenna requirement of Section 15.203.

3.3 Addition to Standard

Item	Test Procedure	Specification	Worst Margin	Results	Remarks
99 % Occupied Band Width	ISED: RSS-Gen 6.7	ISED: -	N/A	-	Conducted

Other than above, no addition, exclusion nor deviation has been made from the standard.

3.4 Uncertainty

Measurement uncertainty is not taken into account when stating conformity with a specified requirement.
Note: When margins obtained from test results are less than the measurement uncertainty, the test results may exceed the limit.

The following uncertainties have been calculated to provide a confidence level of 95 % using a coverage factor $k=2$.

Antenna terminal test	Uncertainty (+/-)
Power Measurement above 1 GHz (Average Detector)	1.3 dB
Power Measurement above 1 GHz (Peak Detector)	1.8 dB
Spurious Emission (Conducted) below 1 GHz	0.91 dB
Conducted Emissions Power Density Measurement 1 GHz to 3 GHz	1.3 dB
Conducted Emissions Power Density Measurement 3 GHz to 18 GHz	2.5 dB
Spurious Emission (Conducted) 18 GHz to 26.5 GHz	2.8 dB
Spurious Emission (Conducted) 26.5 GHz to 40 GHz	2.6 dB
Bandwidth Measurement	0.012 %
Duty Cycle and Time Measurement	0.27 %
Temperature	2.2 deg.C.
Humidity	4.0 %
Voltage	0.74 %

3.5 Test Location

UL Japan, Inc. Shonan EMC Lab.

1-22-3, Megumigaoka, Hiratsuka-shi, Kanagawa-ken 259-1220 Japan

Telephone: +81-463-50-6400

A2LA Certificate Number: 1266.03

(FCC test firm registration number: 626366, ISED lab company number: 2973D / CAB identifier: JP0001)

Test room	Width x Depth x Height (m)	Size of reference ground plane (m) / horizontal conducting plane	Maximum measurement distance
No.1 Semi-anechoic chamber (SAC1)	20.6 x 11.3 x 7.65	20.6 x 11.3	10 m
No.2 Semi-anechoic chamber (SAC2)	20.6 x 11.3 x 7.65	20.6 x 11.3	10 m
No.3 Semi-anechoic chamber (SAC3)	12.7 x 7.7 x 5.35	12.7 x 7.7	5 m
No.4 Semi-anechoic chamber (SAC4)	8.1 x 5.1 x 3.55	8.1 x 5.1	-
Wireless anechoic chamber 1 (WAC1)	9.5 x 6.0 x 5.4	9.5 x 6.0	3 m
Wireless anechoic chamber 2 (WAC2)	9.5 x 6.0 x 5.4	9.5 x 6.0	3 m
No.1 Shielded room	6.8 x 4.1 x 2.7	6.8 x 4.1	-
No.2 Shielded room	6.8 x 4.1 x 2.7	6.8 x 4.1	-
No.3 Shielded room	6.3 x 4.7 x 2.7	6.3 x 4.7	-
No.4 Shielded room	4.4 x 4.7 x 2.7	4.4 x 4.7	-
No.5 Shielded room	7.8 x 6.4 x 2.7	7.8 x 6.4	-
No.6 Shielded room	7.8 x 6.4 x 2.7	7.8 x 6.4	-
No.8 Shielded room	3.45 x 5.5 x 2.4	3.45 x 5.5	-
No.1 Measurement room	2.55 x 4.1 x 2.5	-	-
No.2 Measurement room	4.5 x 3.5 x 2.5	-	-
Wireless shielded room 1	3.0 x 4.5 x 2.7	3.0 x 4.5	-
Wireless shielded room 2	3.0 x 4.5 x 2.7	3.0 x 4.5	-

3.6 Test Data, Test Instruments, and Test Set Up

Refer to APPENDIX.

SECTION 4: Operation of EUT during testing

4.1 Operating Mode(s)

Mode	Remarks*
IEEE 802.11a (11a)	54 Mbps, PN9
IEEE 802.11n MIMO 20 MHz BW (11n-20)	MCS 14 (GI 800 ns), PN9
IEEE 802.11ac MIMO 20 MHz BW (11ac-20)	MCS 5 (GI 800 ns, 2 SS), PN9
IEEE 802.11ax MIMO 20 MHz BW (11ax-20)	MCS 5 (GI 1600 ns, 2 SS), PN9
IEEE 802.11n MIMO 40 MHz BW (11n-40)	MCS 13 (GI 800 ns), PN9
IEEE 802.11ac MIMO 40 MHz BW (11ac-40)	MCS 5 (GI 800 ns, 2 SS), PN9
IEEE 802.11ax MIMO 40 MHz BW (11ax-40)	MCS 10 (GI 1600 ns, 2 SS), PN9
IEEE 802.11ac MIMO 80 MHz BW (11ac-80)	MCS 5 (GI 800 ns, 2 SS), PN9
IEEE 802.11ax MIMO 80 MHz BW (11ax-80)	MCS 7 (GI 1600 ns, 2 SS), PN9
*The worst antenna and condition was determined based on the test result of Maximum Conducted Output Power.	
*Power of the EUT was set by the software as follows; Power See the below table Setting: Software: wifi_5g_serial Version 1 (Used for worst rate check only) (Date: 2023.4.3, Storage location: Driven by connected PC) wifi_5g_serial Version 3 (Date: 2023.4.24, Storage location: Driven by connected PC) OFDMA_TX_5G_Serial_Version 4 (Date: 2023.4.28, Storage location: Driven by connected PC)	
*This setting of software is the worst case. Any conditions under the normal use do not exceed the condition of setting. In addition, end users cannot change the settings of the output power of the product.	
Test operating mode was determined as follows according to "Section 1 of 6 802.11 a/b/g/n testing - Managing Complex Regulatory Approvals - " of TCB Council Workshop October 2009 and also was judged the necessity of 802.11ac/ax mode by the pre-test.	

Power Setting:

		TPC function: OFF			TPC function: ON		
		20 MHz BW	40 MHz BW	80 MHz BW	20 MHz BW	40 MHz BW	80 MHz BW
OFDM		3.0	2.5	2.0	-1.0	-1.5	-2.0
OFDMA	26-tone RU	2.0	2.0	2.0	-2.0	-2.0	-2.0
	52-tone RU	3.0	2.5	2.0	-1.0	-1.5	-2.0
	106-tone RU	3.0	2.5	2.0	-1.0	-1.5	-2.0
	242-tone RU	3.0	2.5	2.0	-1.0	-1.5	-2.0
	484-tone RU	-	2.5	2.0	-	-1.5	-2.0
	996-tone RU	-	-	2.0	-	-	-2.0

*The Details of Operation Mode(s)

Test Item	Operating Mode	Tested Antenna	Tested Frequency	
			Lower Band	Upper Band
99 % Occupied Bandwidth	Tx 11a Tx 11n-20 Tx 11ac-20 Tx 11ax-20 (OFDM) Tx 11ax-20 (OFDMA)	RF1 *2)	5180 MHz 5220 MHz 5240 MHz	5745 MHz 5785 MHz 5825 MHz
	Tx 11n-40 Tx 11ac-40 Tx 11ax-40 (OFDM) Tx 11ax-40 (OFDMA)	RF0 *2)	5190 MHz 5230 MHz	5755 MHz 5795 MHz
	Tx 11ac-80 Tx 11ax-80 (OFDM) Tx 11ax-80 (OFDMA)	RF0 *2)	5210 MHz	5775 MHz
6 dB Bandwidth	Tx 11a Tx 11n-20 Tx 11ac-20 Tx 11ax-20 (OFDM) Tx 11ax-20 (OFDMA)	RF1 *2)	-	5745 MHz 5785 MHz 5825 MHz
	Tx 11n-40 Tx 11ac-40 Tx 11ax-40 (OFDM) Tx 11ax-40 (OFDMA)	RF0 *2)	-	5755 MHz 5795 MHz
	Tx 11ac-80 Tx 11ax-80 (OFDM) Tx 11ax-80 (OFDMA)	RF0 *2)	-	5775 MHz
Maximum Conducted Output Power, Maximum Power Spectral Density	Tx 11a Tx 11n-20 Tx 11ac-20 Tx 11ax-20 (OFDM) Tx 11ax-20 (OFDMA)	RF0 + RF1	5180 MHz 5220 MHz 5240 MHz	5745 MHz 5785 MHz 5825 MHz
	Tx 11n-40 Tx 11ac-40 Tx 11ax-40 (OFDM) Tx 11ax-40 (OFDMA)	RF0 + RF1	5190 MHz 5230 MHz	5755 MHz 5795 MHz
	Tx 11ac-80 Tx 11ax-80 (OFDM) Tx 11ax-80 (OFDMA)	RF0 + RF1	5210 MHz	5775 MHz
Conducted Spurious Emission	Tx 11ax-20 (OFDMA) *1)	RF1	-	5825 MHz
*1) The mode was tested as a representative, because it had the highest power at antenna terminal test.				
*2) The test was performed with the antenna that had higher power as a representative.				

4.2 Configuration and Peripherals

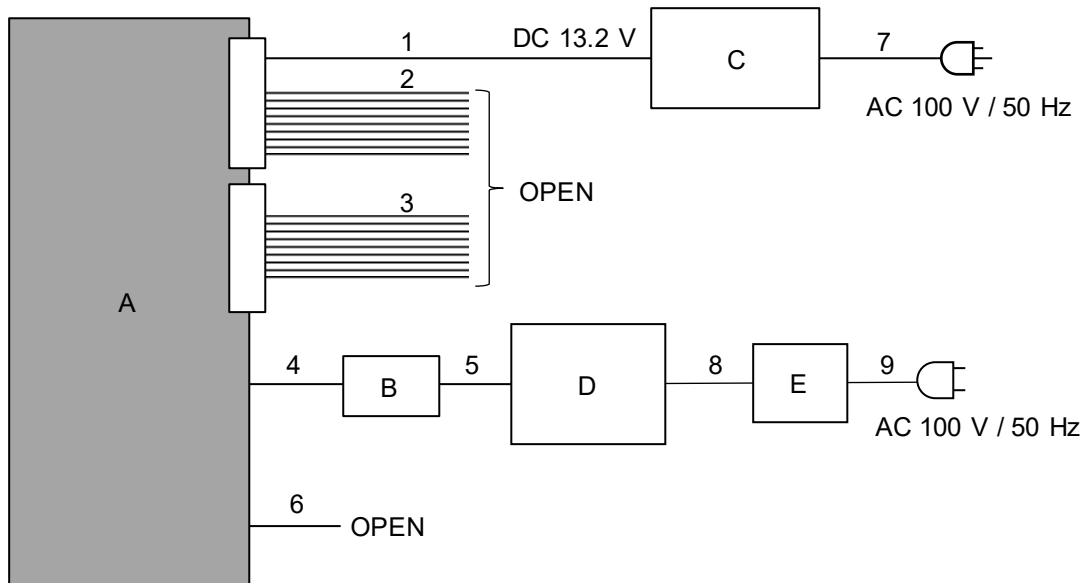

Description of EUT and Support Equipment

No.	Item	Model number	Serial Number	Manufacturer	Remarks
A	Car Navigation	AT2403	008	Panasonic	EUT
B	Jig Board	-	-	-	-
C	Power Supply(DC)	PAN35-10A	DE001677	KIKUSUI	-
D	Laptop Computer	ThinkPad E14 Gen2	PF397TQG	LENOVO	-
E	AC Adapter	ADLX65YCC2D	8SSA10R16922C2TJ19M1368	LENOVO	-

List of Cables Used

No.	Name	Length (m)	Shield		Remarks
			Cable	Connector	
1	DC	1.0 + 1.9	Unshielded	Unshielded	-
2	Signal	1.0	Unshielded	Unshielded	-
3	Signal	1.0	Unshielded	Unshielded	-
4	Signal	0.1	Unshielded	Unshielded	-
5	USB	0.8	Shielded	Shielded	-
6	Signal	0.1	Unshielded	Unshielded	-
7	AC	2.0	Unshielded	Unshielded	-
8	DC	1.8	Unshielded	Unshielded	-
9	AC	0.9	Unshielded	Unshielded	-

SECTION 5: Antenna Terminal Conducted Tests

Test Procedure

The tests were made with below setting connected to the antenna port.

Test	Span	RBW	VBW	Sweep time	Detector	Trace	Instrument used and Test method
99 % Occupied Bandwidth *1)	Enough width to display emission skirts	1 % to 5 % of OBW	≥ 3 RBW	Auto	Peak	Max Hold	Spectrum Analyzer
6 dB Bandwidth	Enough to capture the emission	100 kHz	300 kHz	Auto	Peak	Max Hold	Spectrum Analyzer
Maximum Conducted Output Power	-	-	-	Auto	Average	-	Power Meter (Sensor: 160 MHz BW) (Method PM-G)
Maximum Power Spectral Density	Encompass the entire EBW	1 MHz or 100 kHz *2)	≥ 3 RBW	Auto	RMS or Sample Power Averaging (300 times)	Clear Write	Spectrum Analyzer
Conducted Spurious Emission*3) *4)	9 kHz to 150 kHz	200 Hz	620 Hz	Auto	Peak	Max Hold	Spectrum Analyzer
	150 kHz to 30 MHz	10 kHz	30 kHz				

*1) Peak hold was applied as Worst-case measurement.

*2) KDB 789033 D02 says that RBW is set to be 500 kHz for 5.725 GHz to 5.850 GHz, but it is not possible with spectrum analyzer, so RBW Correction Factor ($10 \log(500 \text{ kHz} / 100 \text{ kHz})$) was added to the test result.

*3) In the frequency range below 30 MHz, RBW was narrowed to separate the noise contents.

Then, wide-band noise near the limit was checked separately, however the noise was not detected as shown in the chart.
(9 kHz to 150 kHz: RBW = 200 Hz, 150 kHz to 30 MHz: RBW = 10 kHz)

*4) The limits in CFR 47, Part 15, Subpart C, paragraph 15.209(a), are identical to those in RSS-Gen section 8.9, Table 6, since the measurements are performed in terms of magnetic field strength and converted to electric field strength levels (as reported in the table) using the free space impedance of 377 Ohms. For example, the measurement at frequency 9 kHz resulted in a level of 45.5 dBuV/m, which is equivalent to $45.5 - 51.5 = -6.0$ dBuA/m, which has the same margin, 3 dB, to the corresponding RSS-Gen Table 6 limit as it has to 15.209(a) limit.

Test results are rounded off and limit are rounded down, so some differences might be observed.
The equipment and cables were not used for factor 0 dB of the data sheets.

Test Data : APPENDIX
Test Result : Pass

99 % Occupied Bandwidth

Test place	Shonan EMC Lab. No.5 Shielded Room
Date	May 8, 2023
Temperature / Humidity	26 deg. C / 35 % RH
Engineer	Shiro Kobayashi
Mode	Tx

11ax-20(OFDMA)

Antenna	RU Type	Tested Frequency [MHz]	RU Index	99 % Occupied Bandwidth [kHz]
RF1	26-tone RU	5180	0	18595.7
			4	17227.7
			8	18543.1
		5220	0	18610.6
			4	17226.5
			8	18519.5
		5240	0	18584.7
			4	17212.6
			8	18538.2
		5745	0	18608.5
			4	17219.2
			8	18521.0
		5785	0	18594.4
			4	17206.1
			8	18527.8
		5825	0	18618.0
			4	17222.4
			8	18515.5

99 % Occupied Bandwidth

Test place	Shonan EMC Lab. No.5 Shielded Room
Date	May 8, 2023
Temperature / Humidity	26 deg. C / 35 % RH
Engineer	Shiro Kobayashi
Mode	Tx

11ax-20(OFDMA)

Antenna	RU Type	Tested Frequency [MHz]	RU Index	99 % Occupied Bandwidth [kHz]
RF1	52-tone RU	5180	37	18423.5
			38	17255.1
			40	18394.1
		5220	37	18442.4
			38	17264.0
			40	18399.9
		5240	37	18407.3
			38	17236.5
			40	18387.3
		5745	37	18431.3
			38	17252.9
			40	18368.4
		5785	37	18424.6
			38	17238.9
			40	18369.1
		5825	37	18452.5
			38	17249.1
			40	18368.4

99 % Occupied Bandwidth

Test place	Shonan EMC Lab. No.5 Shielded Room
Date	May 8, 2023
Temperature / Humidity	26 deg. C / 35 % RH
Engineer	Shiro Kobayashi
Mode	Tx

11ax-20(OFDMA)

Antenna	RU Type	Tested Frequency [MHz]	RU Index	99 % Occupied Bandwidth [kHz]
RF1	106-tone RU	5180	53	18443.9
			54	18330.3
		5220	53	18448.0
			54	18326.3
		5240	53	18420.5
			54	18309.5
		5745	53	18459.3
			54	18304.2
		5785	53	18441.9
			54	18296.4
		5825	53	18455.4
			54	18300.1

11ax-20(OFDMA)

Antenna	RU Type	Tested Frequency [MHz]	RU Index	99 % Occupied Bandwidth [kHz]
RF1	242-tone RU	5180	61	19223.1
		5220	61	19213.4
		5240	61	19203.2
		5745	61	19219.7
		5785	61	19210.0
		5825	61	19225.1

99 % Occupied Bandwidth

Test place	Shonan EMC Lab. No.5 Shielded Room
Date	May 8, 2023
Temperature / Humidity	26 deg. C / 35 % RH
Engineer	Shiro Kobayashi
Mode	Tx

11ax-40(OFDMA)

Antenna	RU Type	Tested Frequency [MHz]	RU Index	99 % Occupied Bandwidth [kHz]
RF0	106-tone RU	5190	53	38001.4
			54	36840.5
			56	37857.9
		5230	53	37956.2
			54	36755.7
			56	37844.8
		5755	53	37964.2
			54	36780.7
			56	37870.1
		5795	53	37905.4
			54	36759.3
			56	37939.5

11ax-40(OFDMA)

Antenna	RU Type	Tested Frequency [MHz]	RU Index	99 % Occupied Bandwidth [kHz]
RF0	242-tone RU	5190	61	37515.1
			62	37815.2
		5230	61	37437.6
			62	37757.3
		5755	61	37482.6
			62	37814.8
		5795	61	37408.6
			62	37779.7

11ax-40(OFDMA)

Antenna	RU Type	Tested Frequency [MHz]	RU Index	99 % Occupied Bandwidth [kHz]
RF0	484-tone RU	5190	65	38331.8
		5230	65	38273.0
		5755	65	38294.8
		5795	65	38264.2

99 % Occupied Bandwidth

Test place	Shonan EMC Lab. No.5 Shielded Room
Date	May 8, 2023
Temperature / Humidity	26 deg. C / 35 % RH
Engineer	Shiro Kobayashi
Mode	Tx

11ax-80(OFDMA)

Antenna	RU Type	Tested Frequency [MHz]	RU Index	99 % Occupied Bandwidth [kHz]
RF0	26-tone RU	5210	0	79200.1
			18	74988.8
			36	78941.6
		5775	0	79045.5
			18	74929.3
			36	79011.6

11ax-80(OFDMA)

Antenna	RU Type	Tested Frequency [MHz]	RU Index	99 % Occupied Bandwidth [kHz]
RF0	52-tone RU	5210	37	78798.8
			44	75424.1
			52	79005.5
		5775	37	78767.7
			44	75230.2
			52	78993.3

11ax-80(OFDMA)

Antenna	RU Type	Tested Frequency [MHz]	RU Index	99 % Occupied Bandwidth [kHz]
RF0	106-tone RU	5210	53	78110.2
			56	75638.1
			60	78453.6
		5775	53	78009.7
			56	75350.5
			60	78436.7

99 % Occupied Bandwidth

Test place	Shonan EMC Lab. No.5 Shielded Room
Date	May 8, 2023
Temperature / Humidity	26 deg. C / 35 % RH
Engineer	Shiro Kobayashi
Mode	Tx

11ax-80(OFDMA)

Antenna	RU Type	Tested Frequency [MHz]	RU Index	99 % Occupied Bandwidth [kHz]
RF0	242-tone RU	5210	61	77661.3
			62	75777.4
			64	77624.6
		5775	61	77468.5
			62	75466.1
			64	78064.6

11ax-80(OFDMA)

Antenna	RU Type	Tested Frequency [MHz]	RU Index	99 % Occupied Bandwidth [kHz]
RF0	484-tone RU	5210	65	77355.9
			66	77380.3
		5775	65	77220.3
			66	77380.8

11ax-80(OFDMA)

Antenna	RU Type	Tested Frequency [MHz]	RU Index	99 % Occupied Bandwidth [kHz]
RF0	996-tone RU	5210	67	77977.4
		5775	67	77924.7

99 % Occupied Bandwidth

11a, RF1

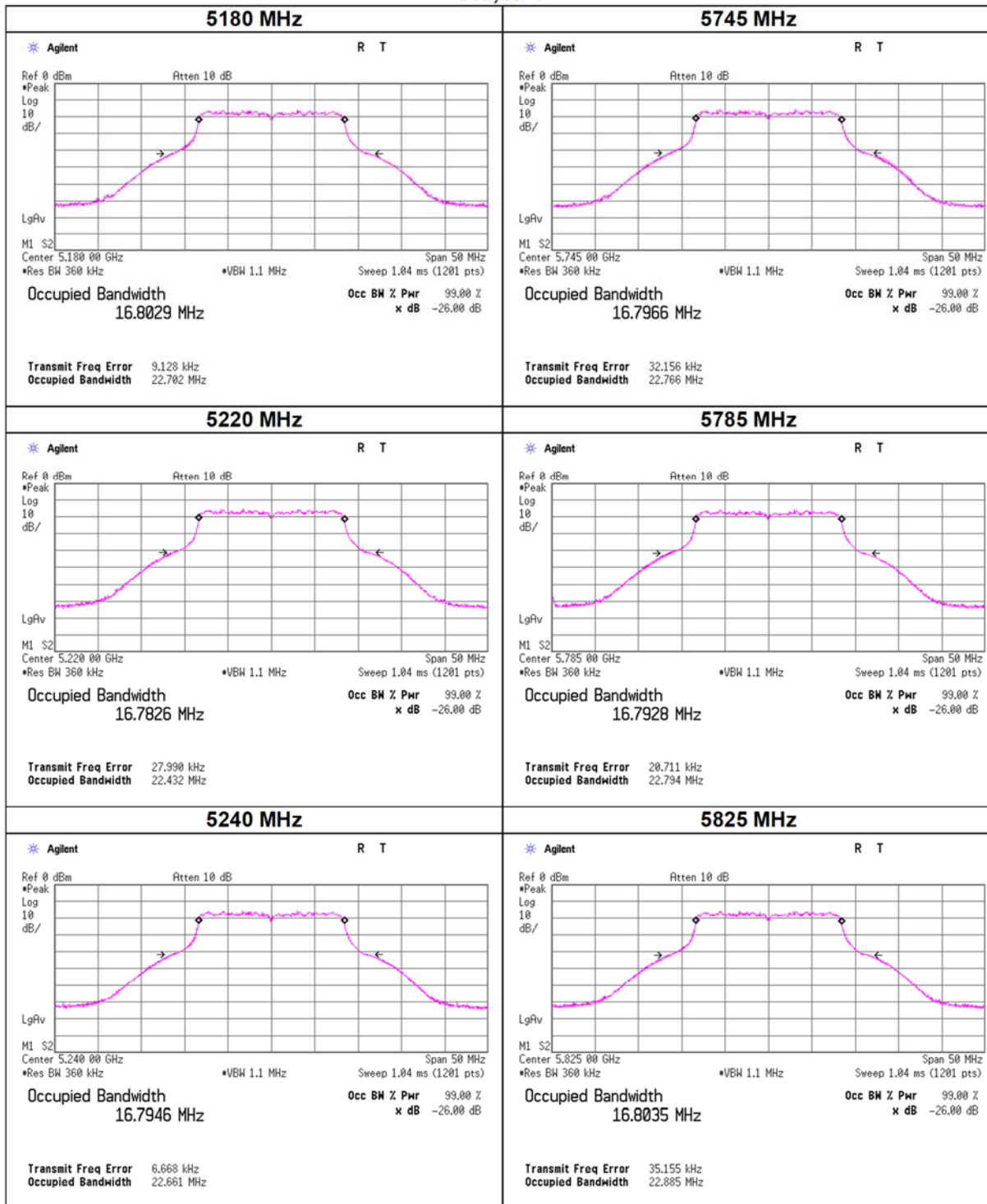

99 % Occupied Bandwidth

11n-20 , RF1

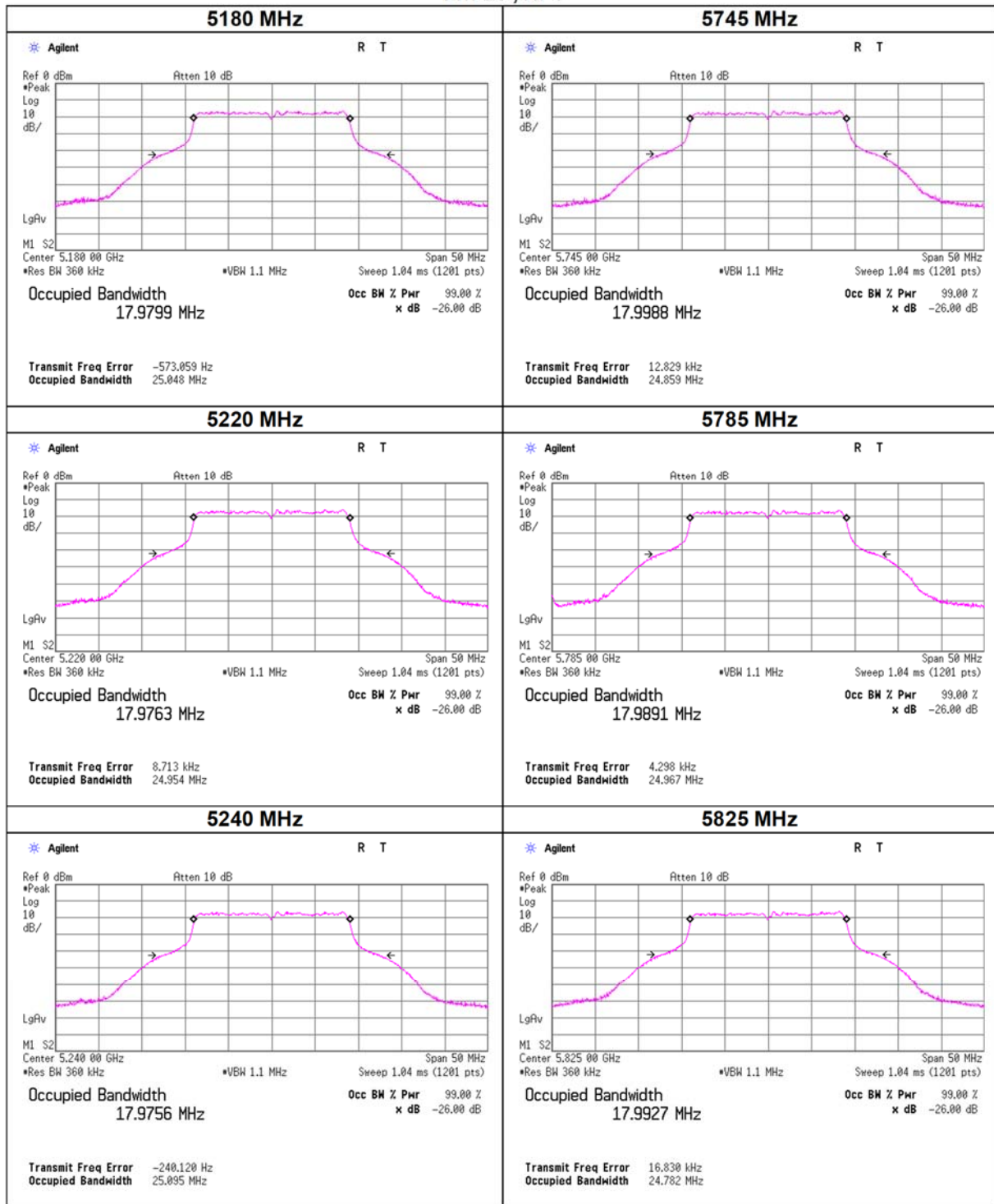

99 % Occupied Bandwidth

11ac-20, RF1

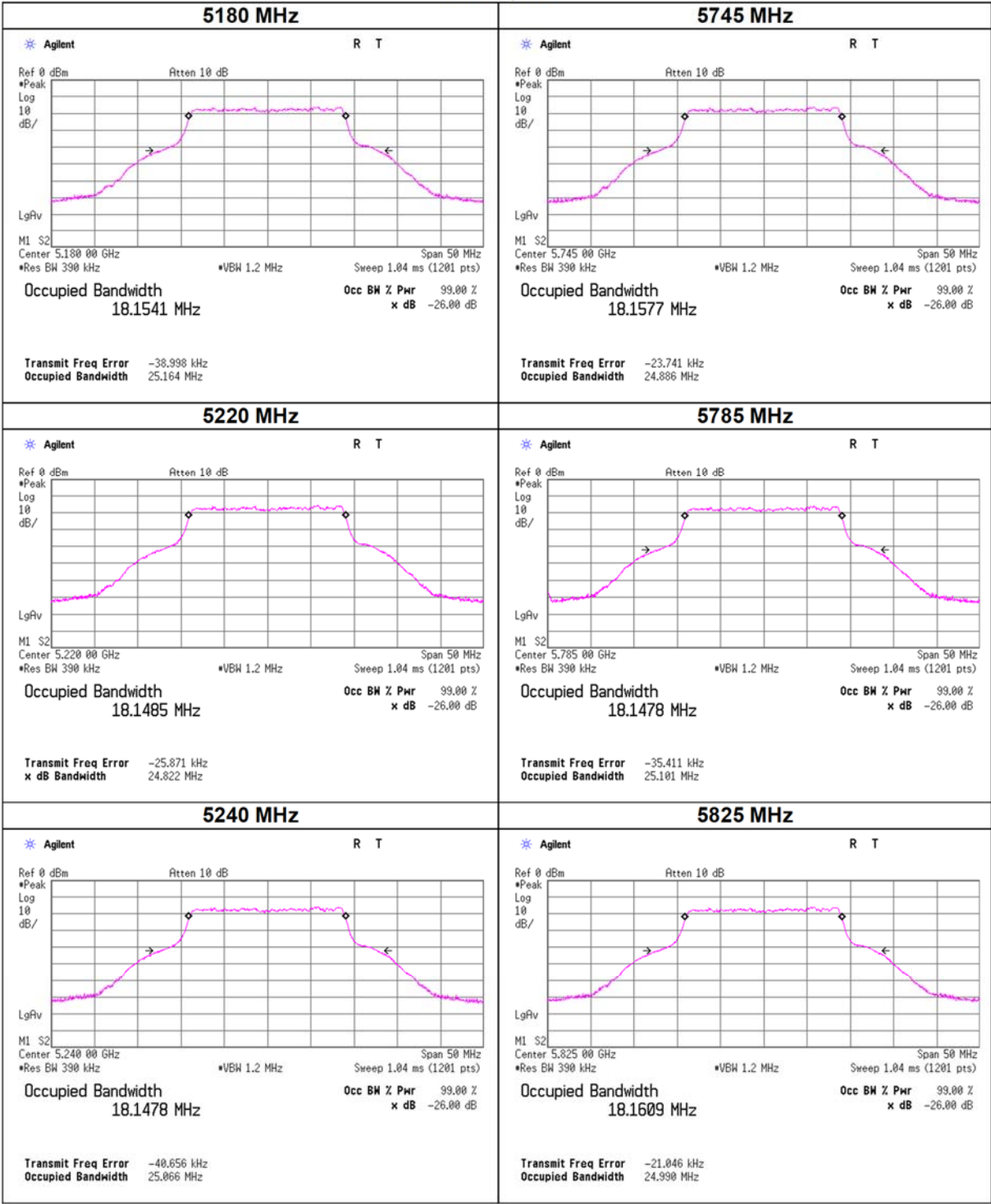

99 % Occupied Bandwidth

11ax-20 (OFDM), RF1

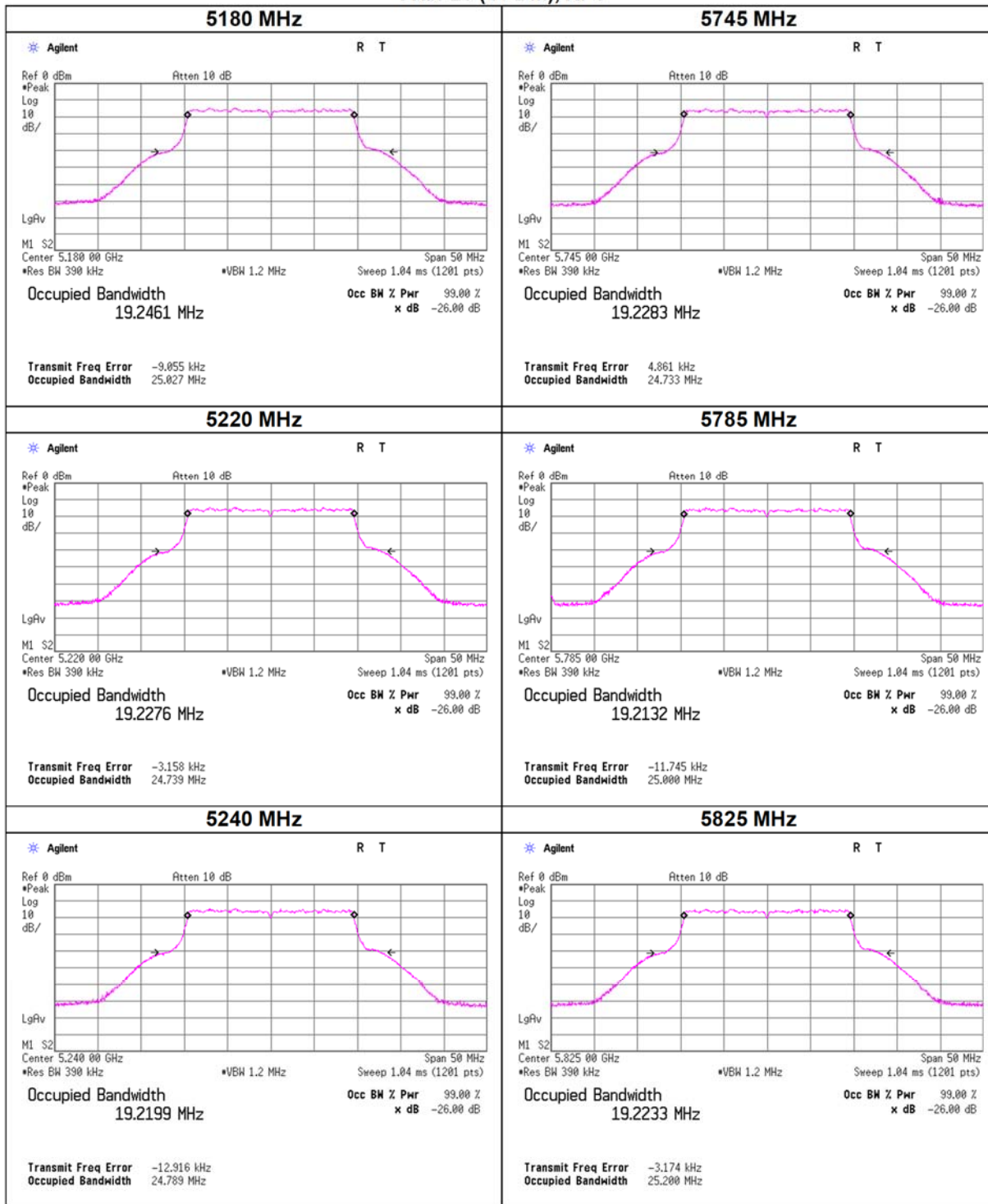

99 % Occupied Bandwidth

11ax-20(OFDMA), RF1, 26-tone RU

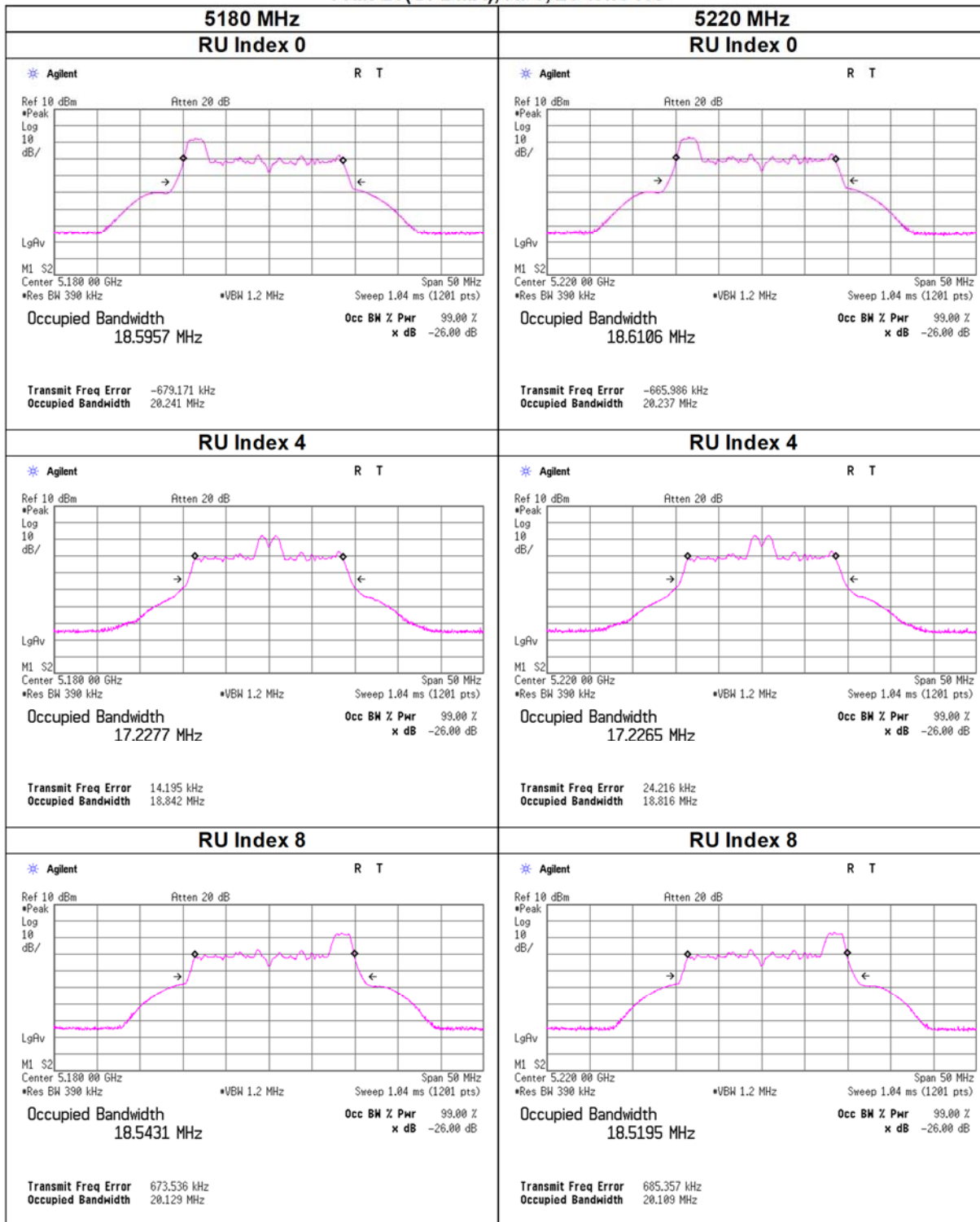

99 % Occupied Bandwidth

11ax-20(OFDMA), RF1, 26-tone RU

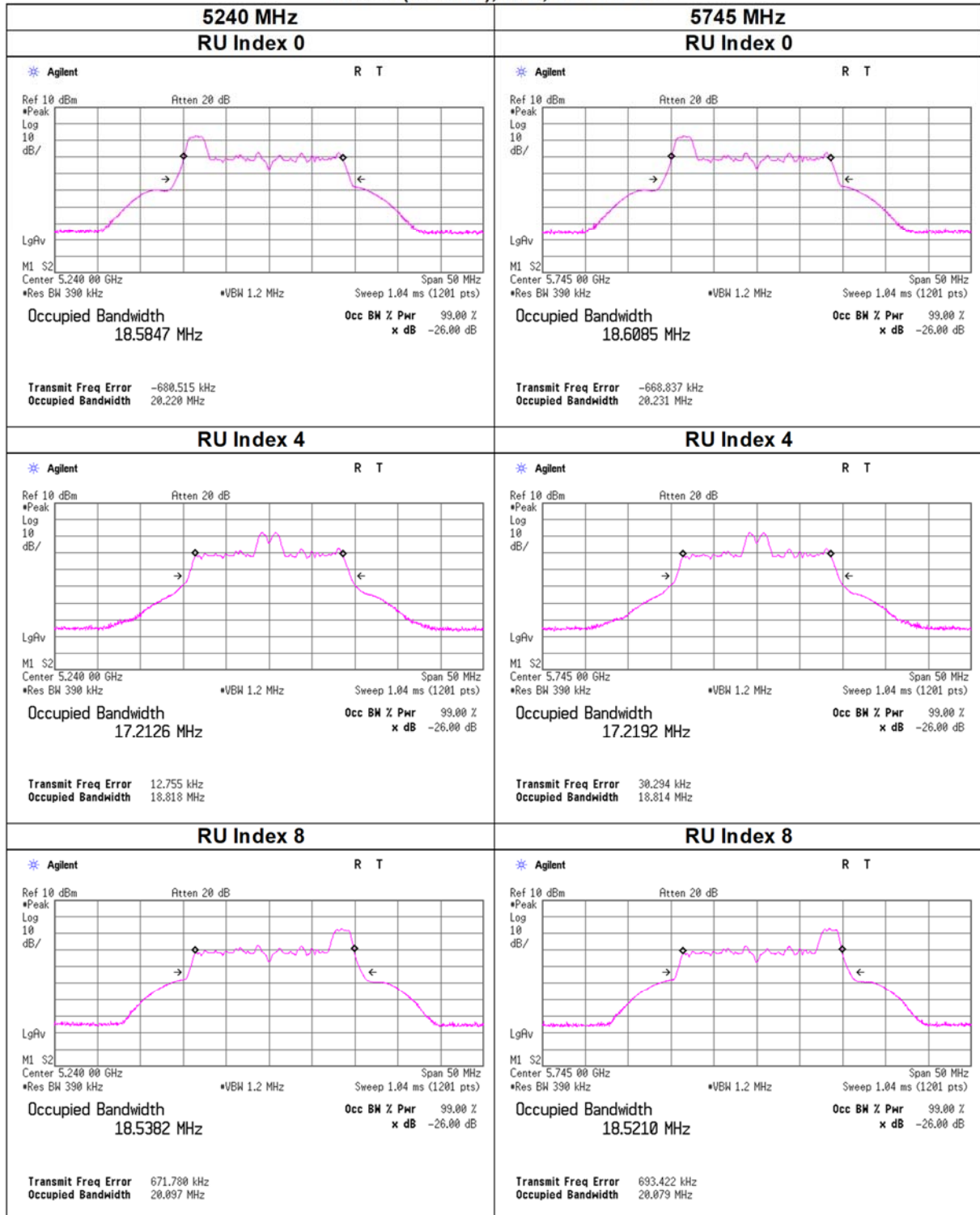

99 % Occupied Bandwidth

11ax-20(OFDMA), RF1, 26-tone RU

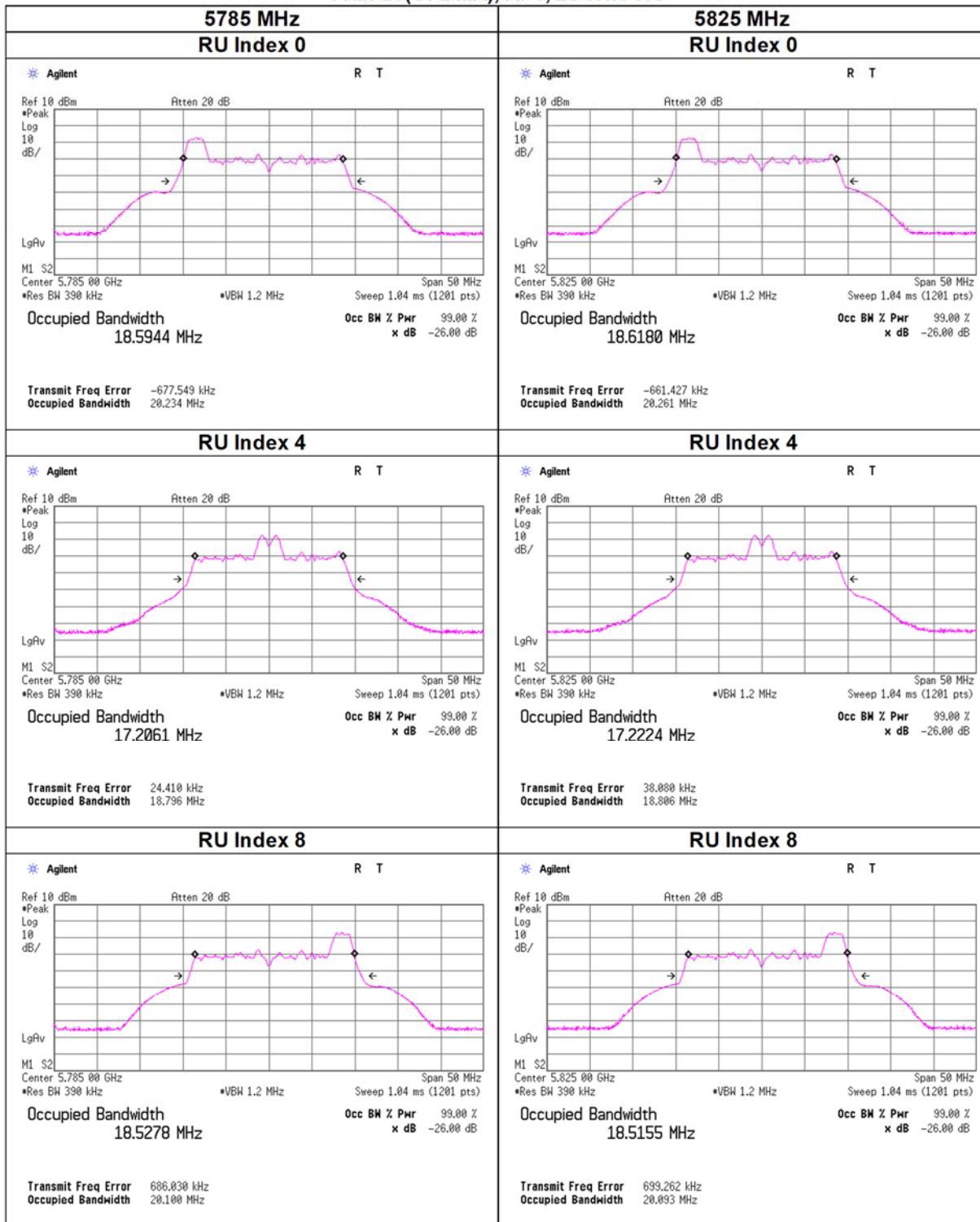

99 % Occupied Bandwidth

11ax-20(OFDMA), RF1, 52-tone RU

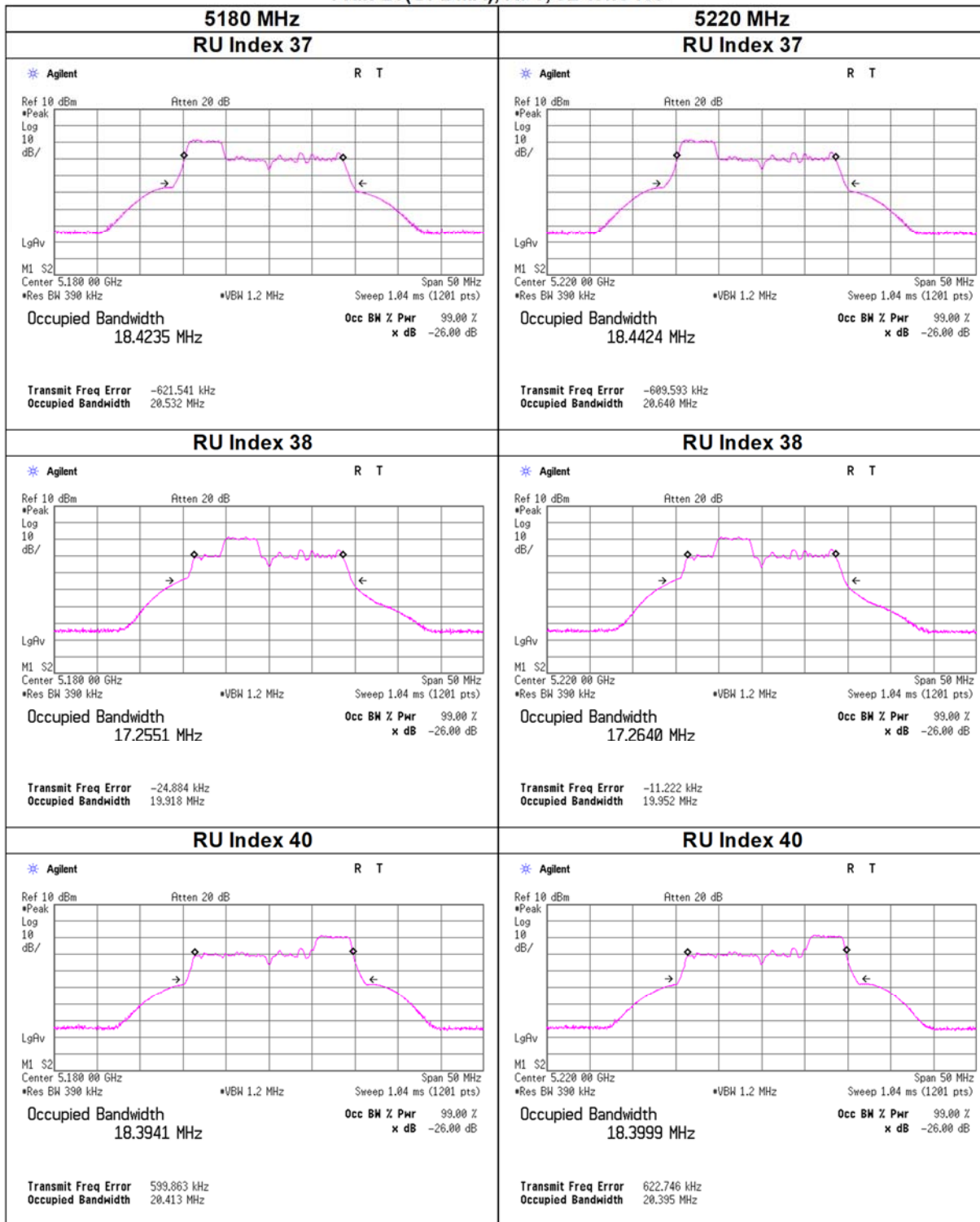

99 % Occupied Bandwidth

11ax-20(OFDMA), RF1, 52-tone RU

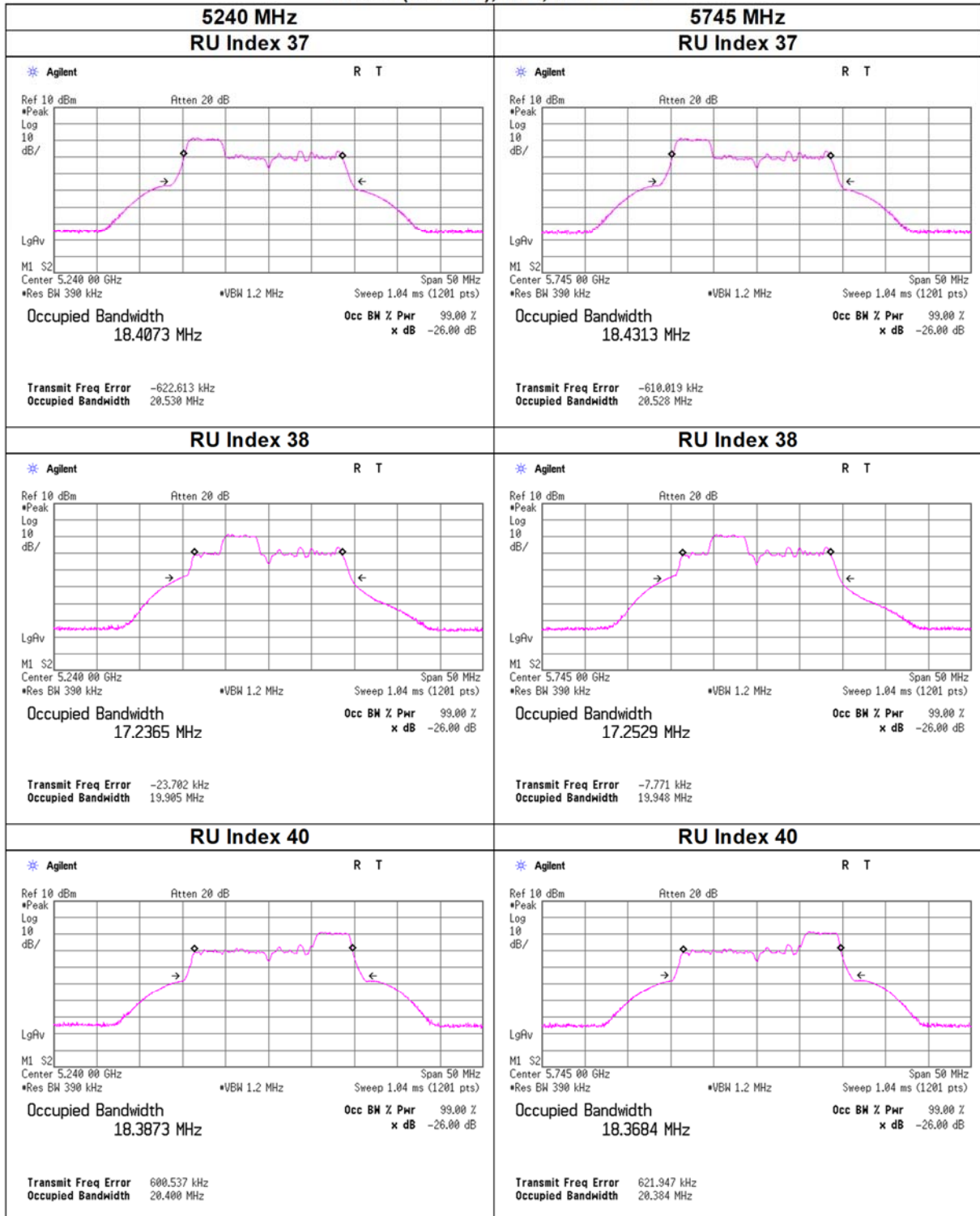

99 % Occupied Bandwidth

11ax-20(OFDMA), RF1, 52-tone RU

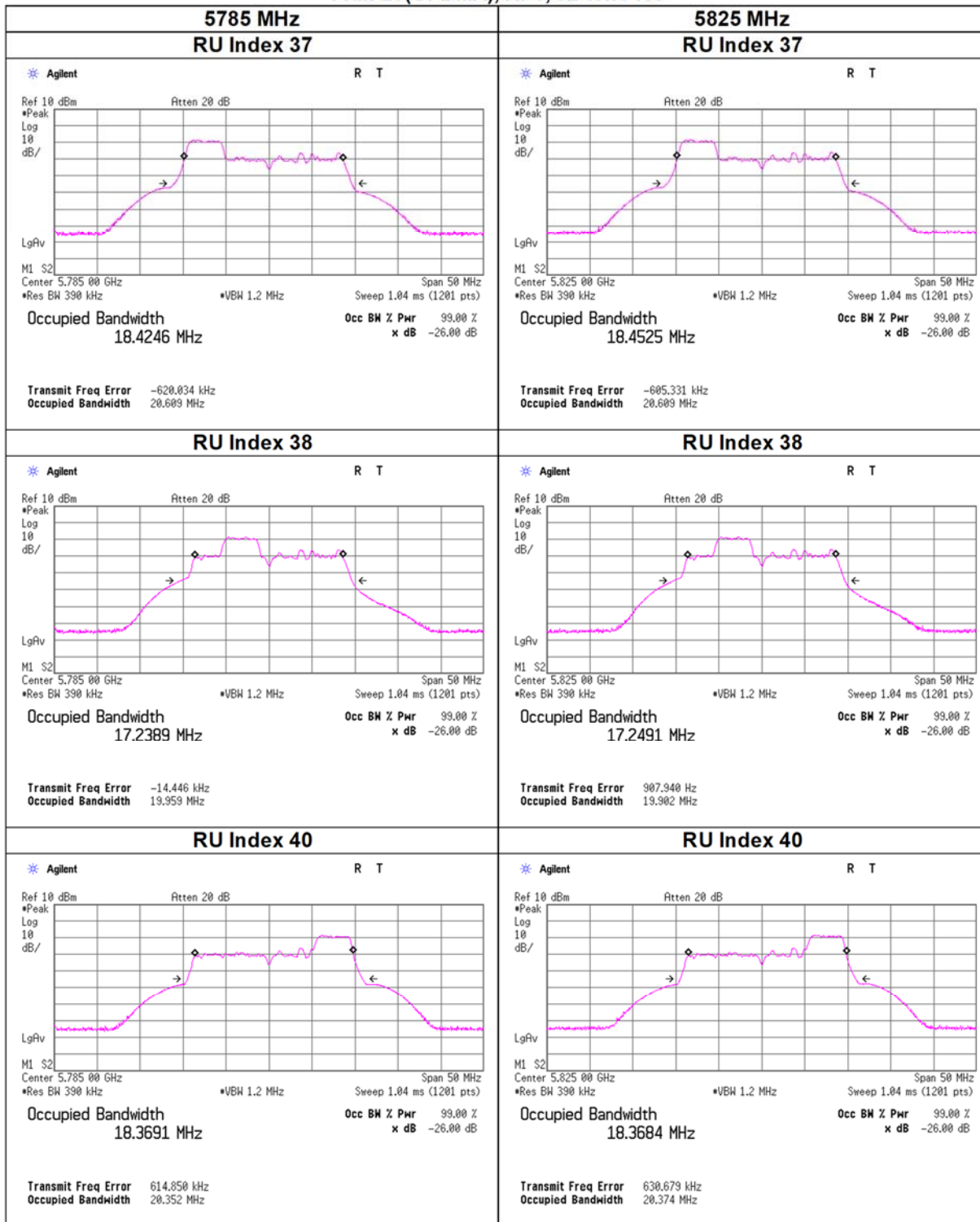

99 % Occupied Bandwidth

11ax-20(OFDMA), RF1, 106-tone RU

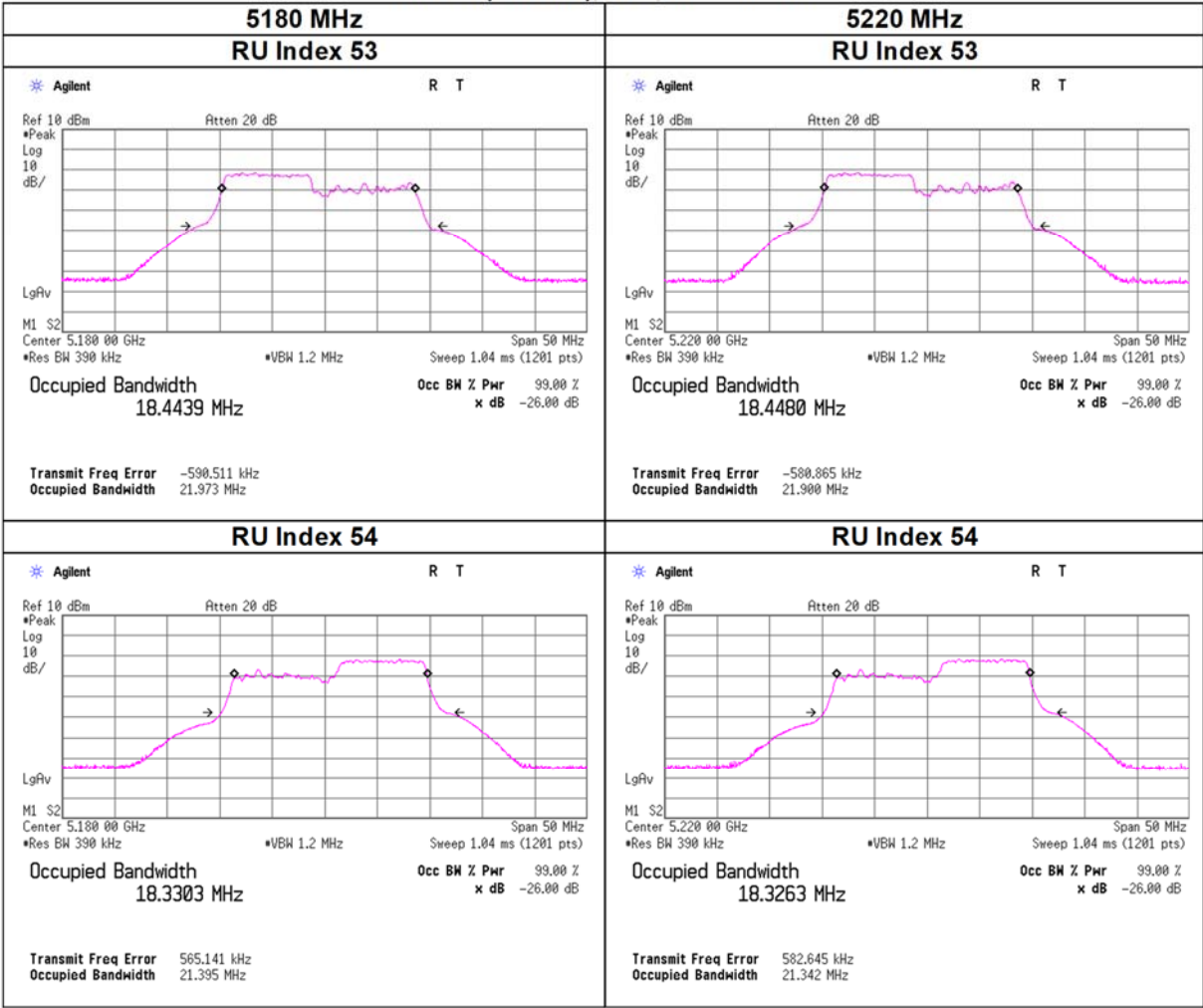

99 % Occupied Bandwidth

11ax-20(OFDMA), RF1, 106-tone RU

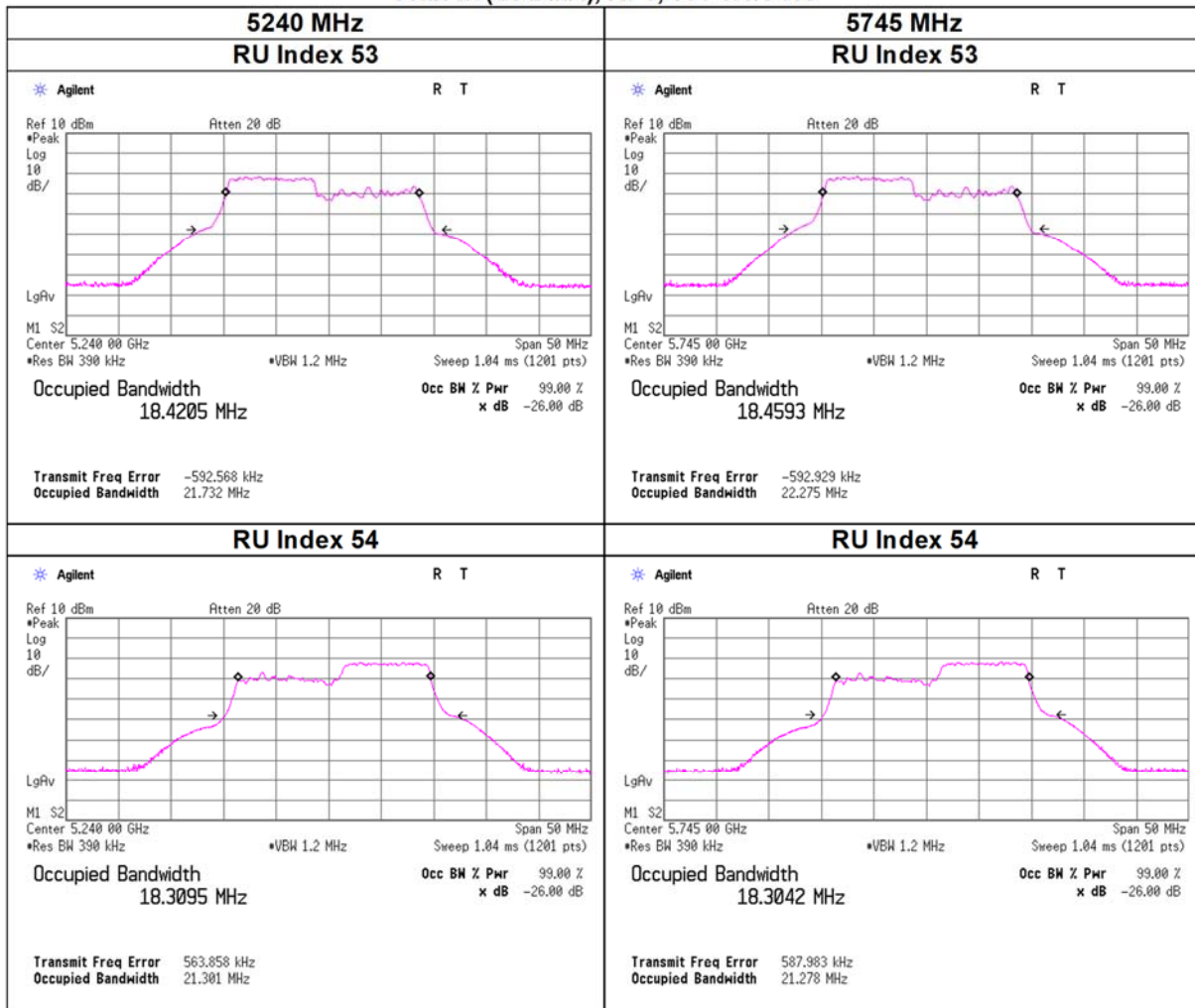

99 % Occupied Bandwidth

11ax-20(OFDMA), RF1, 106-tone RU

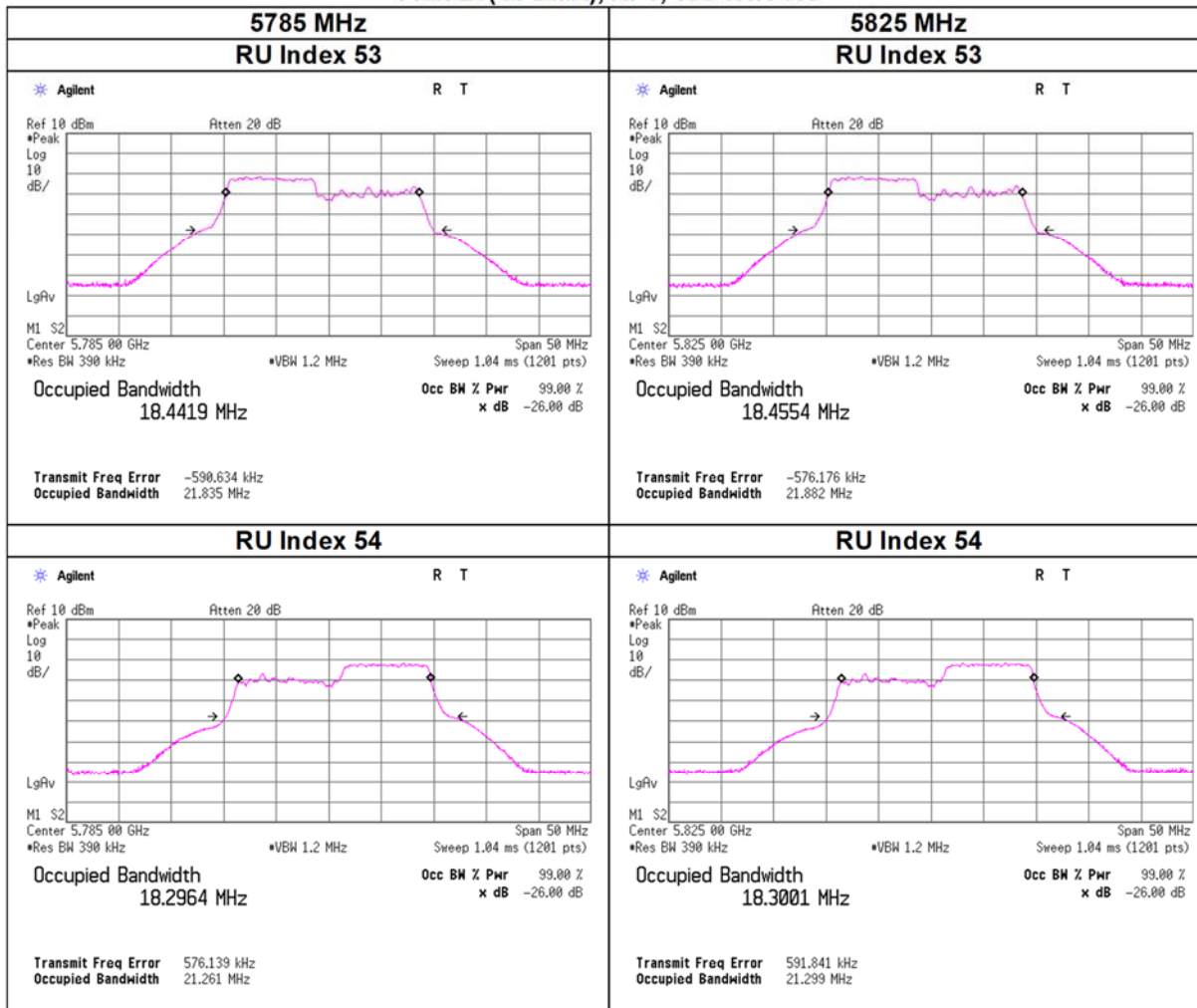

99 % Occupied Bandwidth

11ax-20(OFDMA), RF1, 242-tone RU

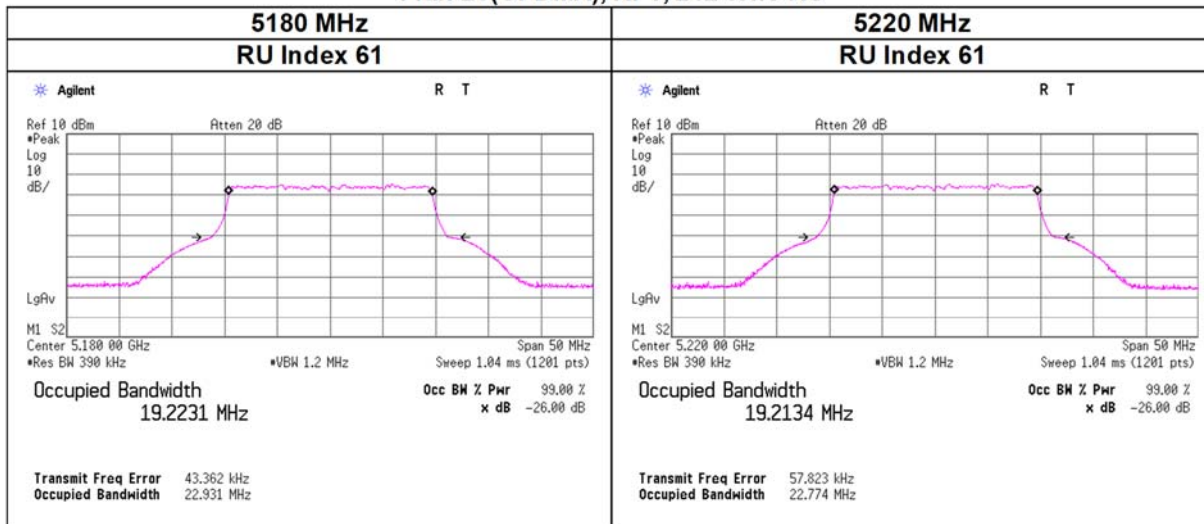

11ax-20(OFDMA), RF1, 242-tone RU

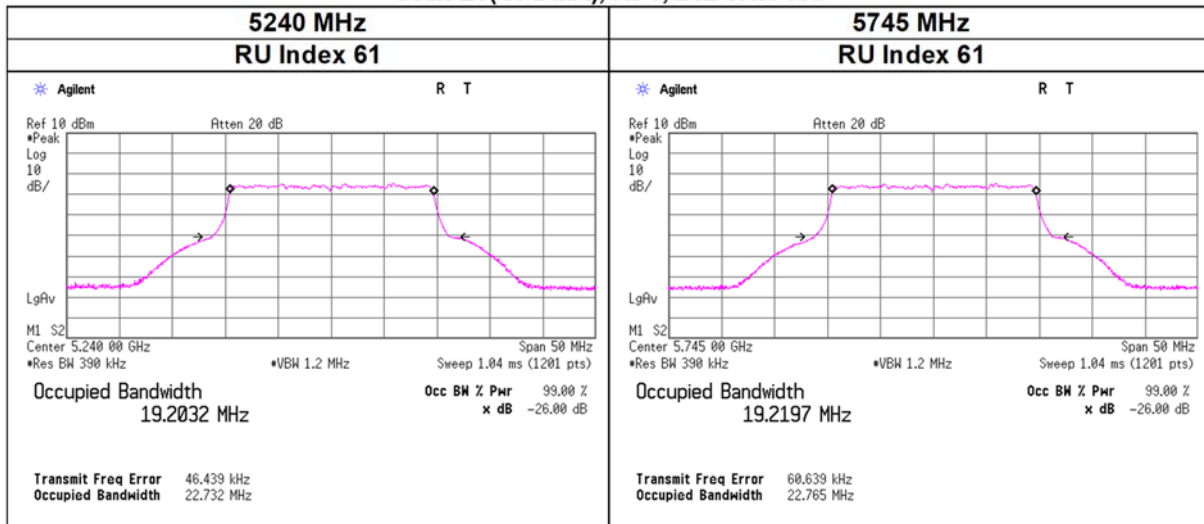

11ax-20(OFDMA), RF1, 242-tone RU

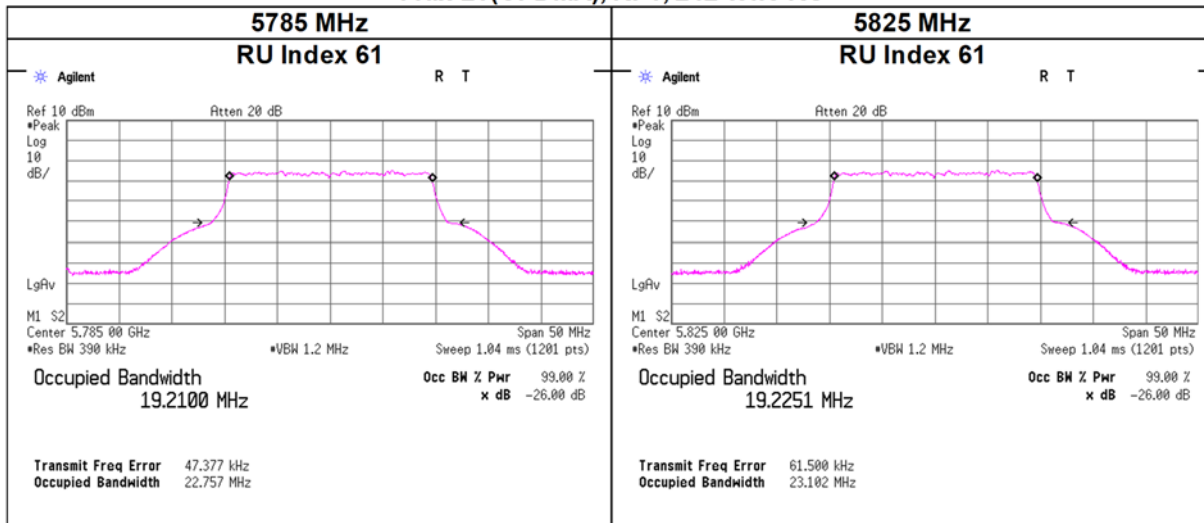

99 % Occupied Bandwidth

11n-40 , RF0

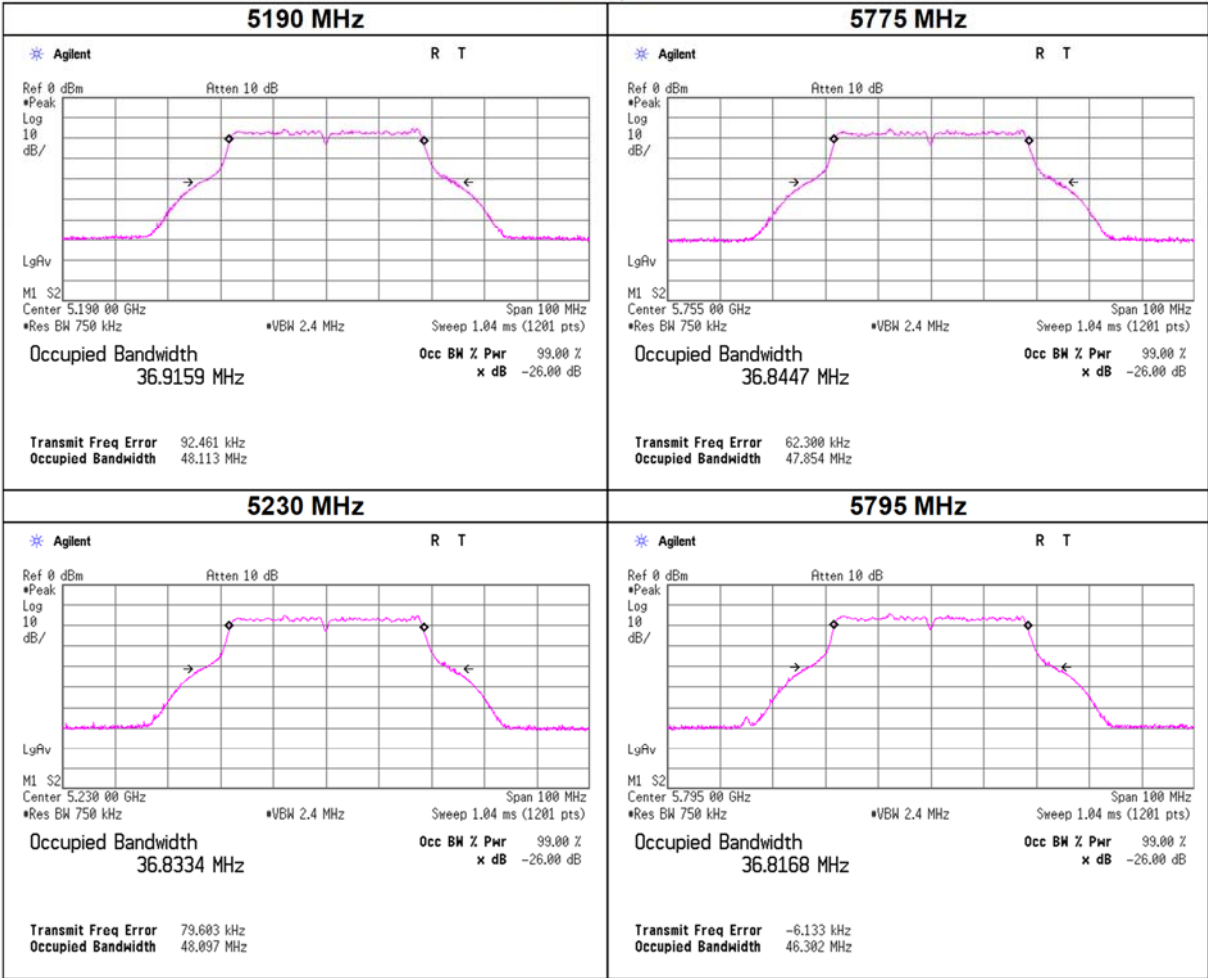

99 % Occupied Bandwidth

11ac-40, RF0

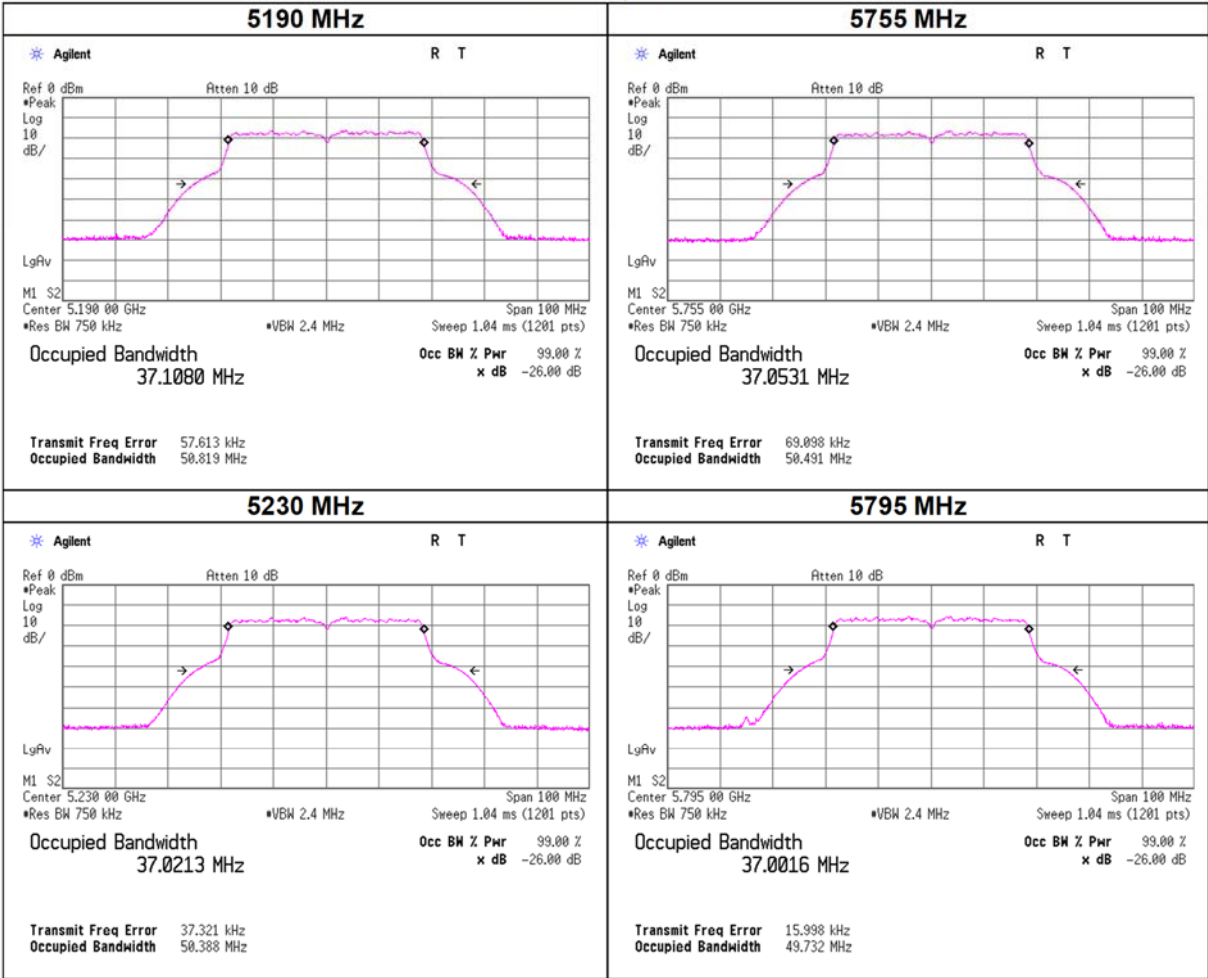

99 % Occupied Bandwidth

11ax-40 (OFDM), RF0

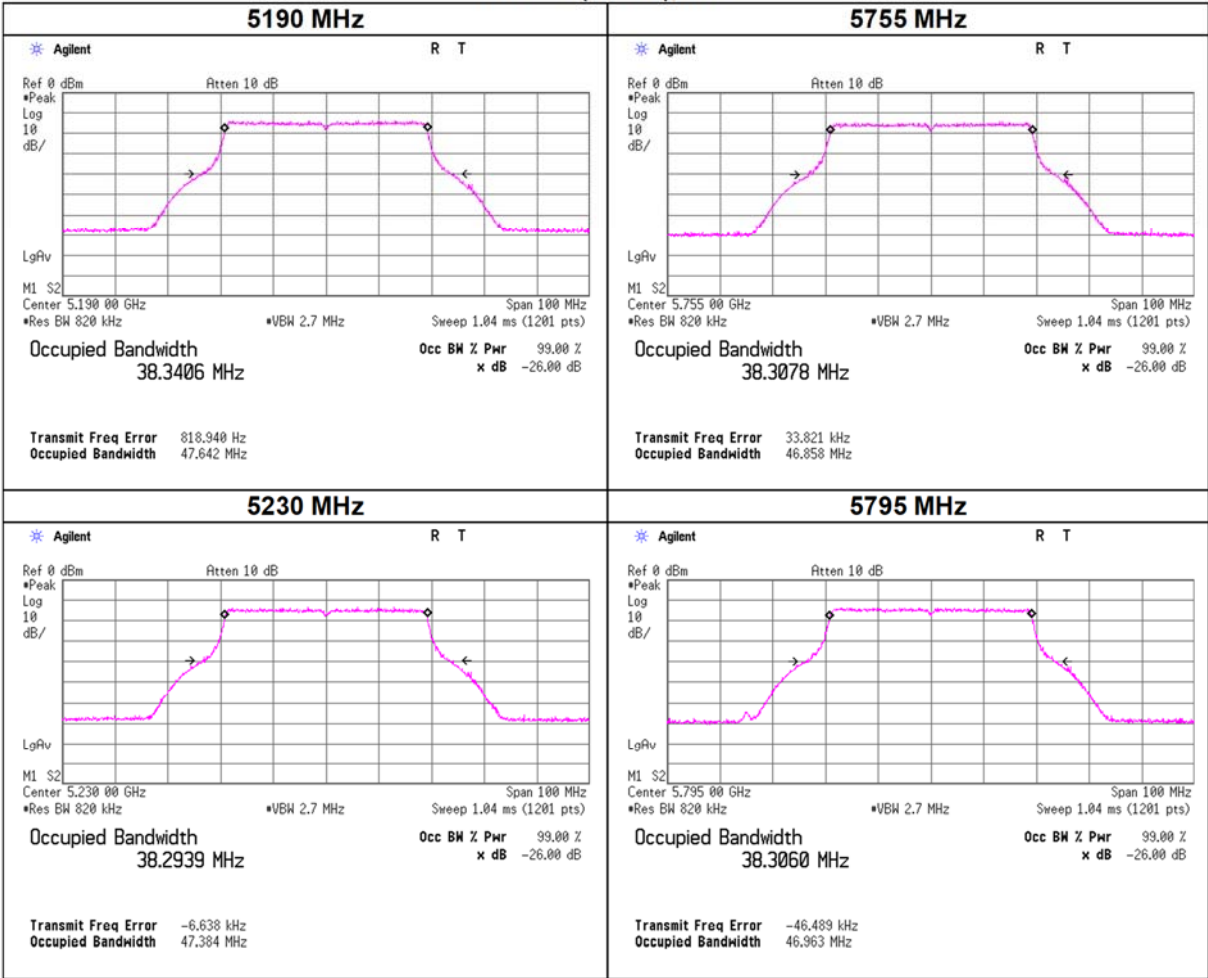

99 % Occupied Bandwidth

11ax-40(OFDMA), RF0, 26-tone RU

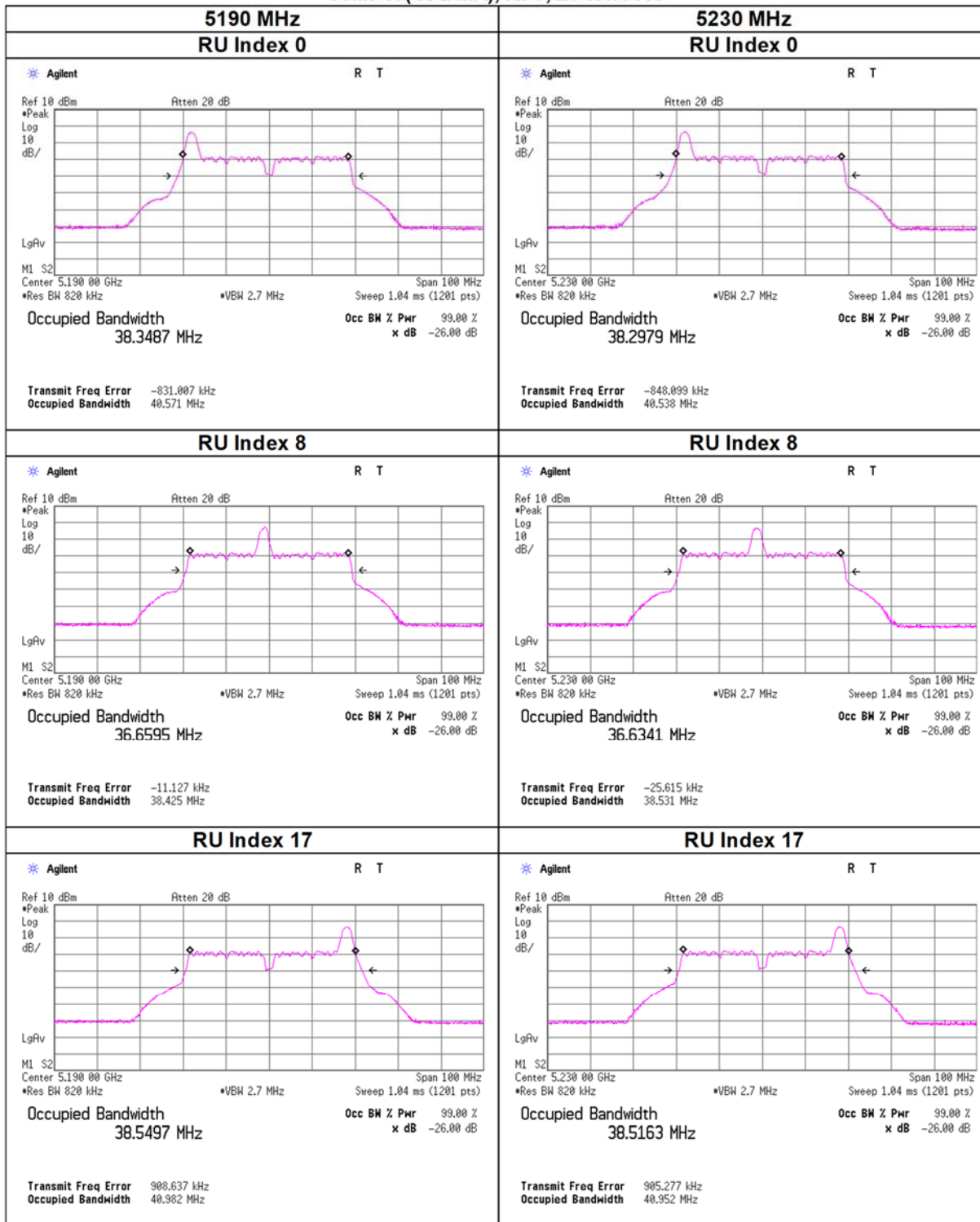

99 % Occupied Bandwidth

11ax-40(OFDMA), RF0, 26-tone RU

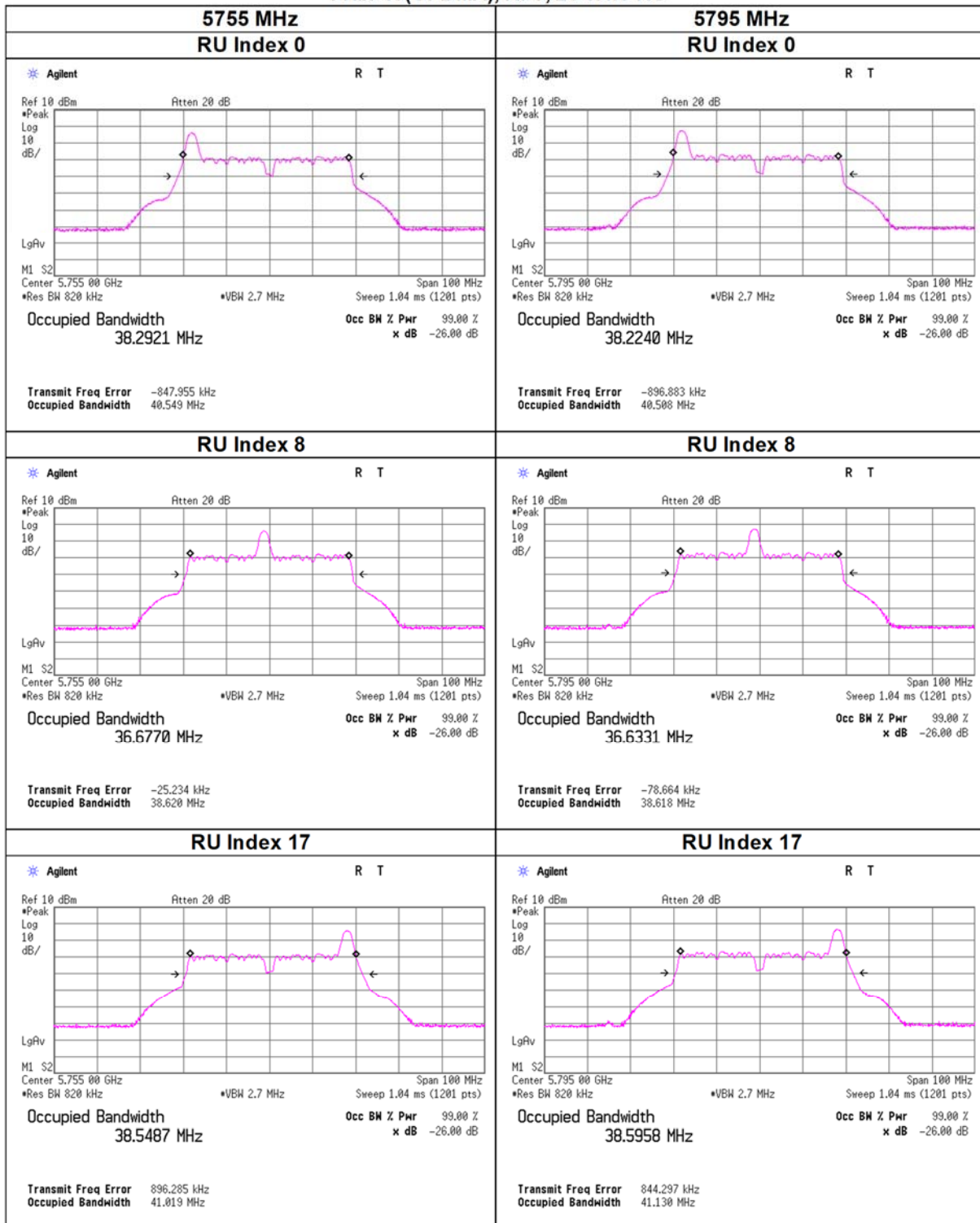

99 % Occupied Bandwidth

11ax-40(OFDMA), RF0, 52-tone RU

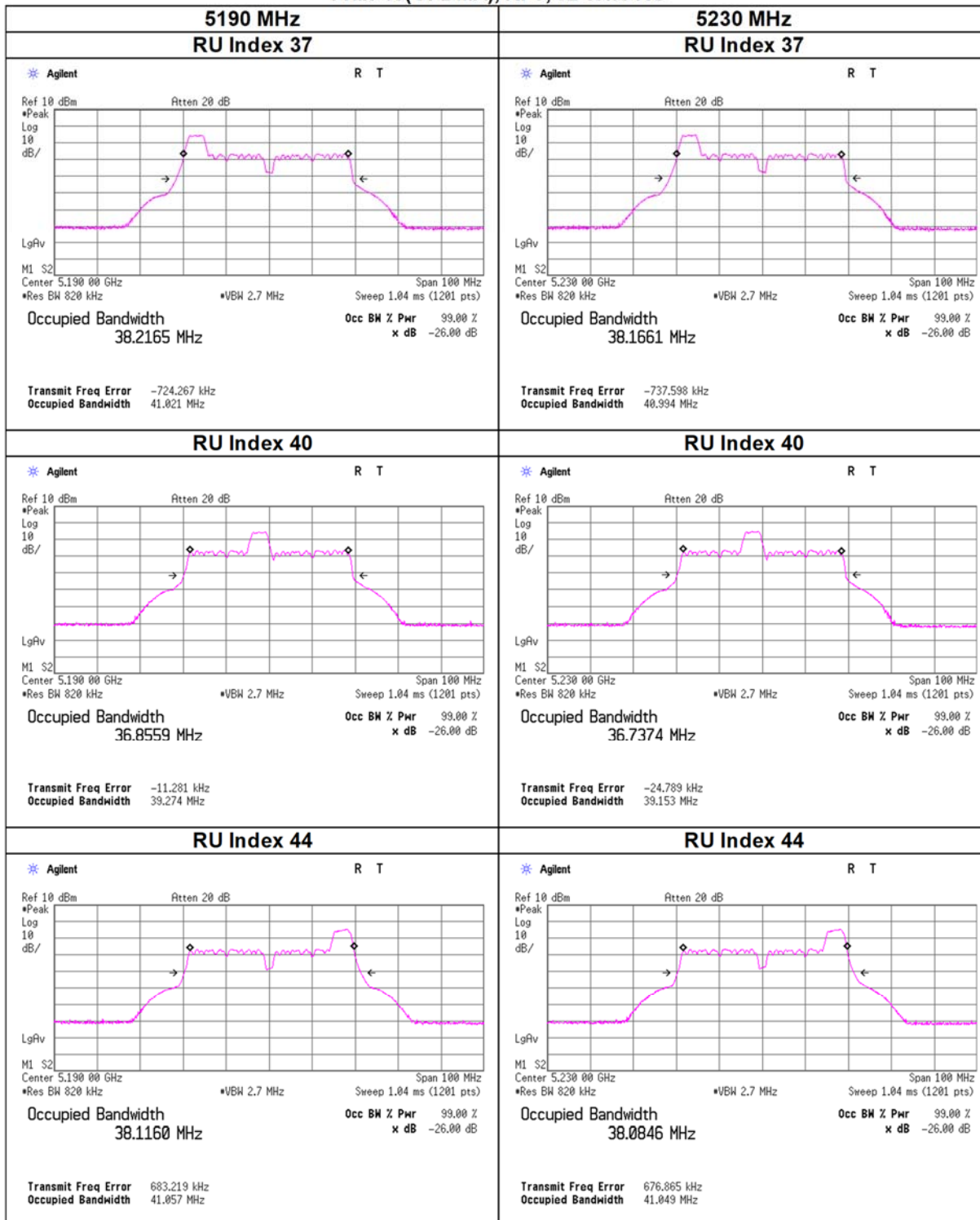

99 % Occupied Bandwidth

11ax-40(OFDMA), RF0, 52-tone RU

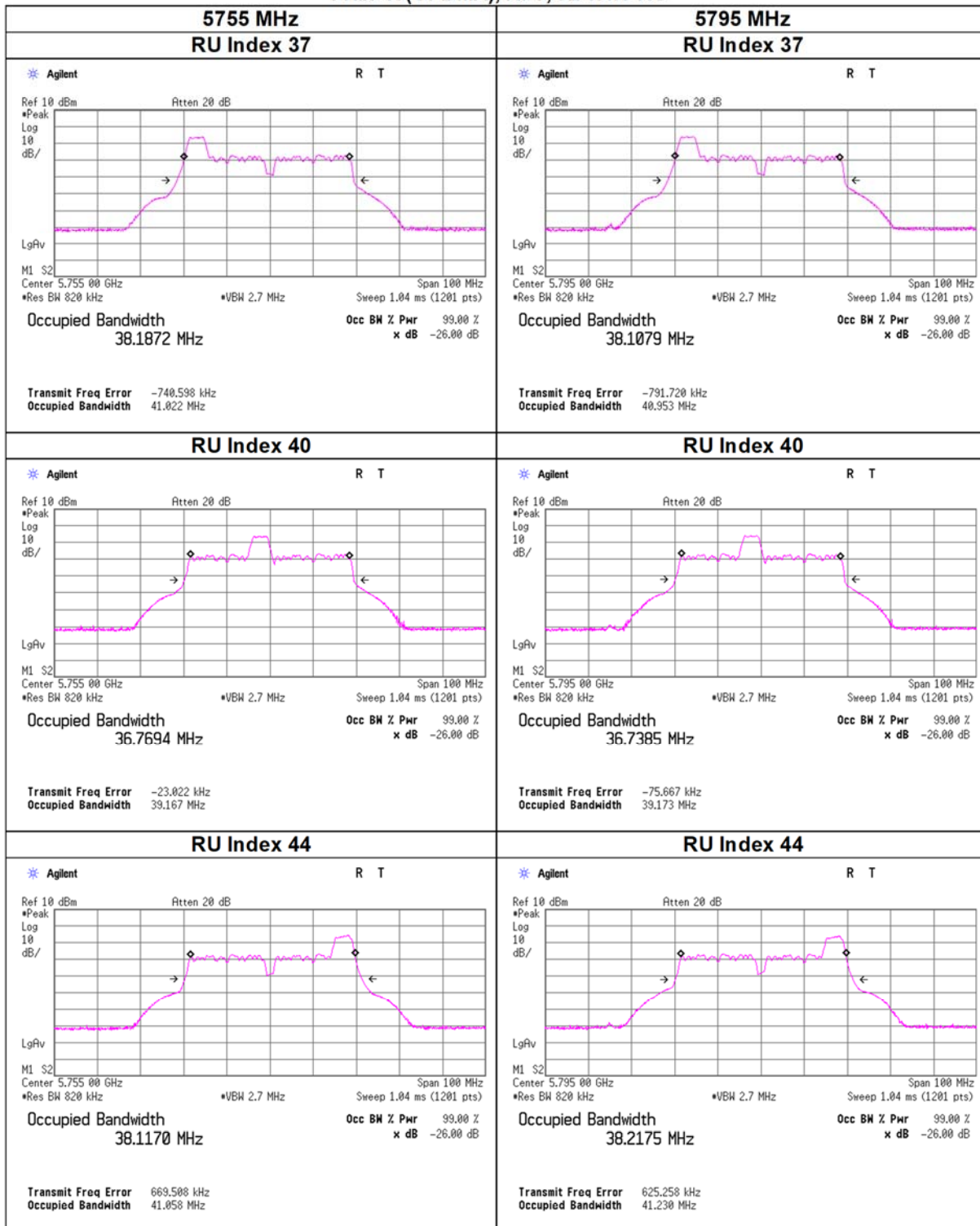

99 % Occupied Bandwidth

11ax-40(OFDMA), RF0, 106-tone RU

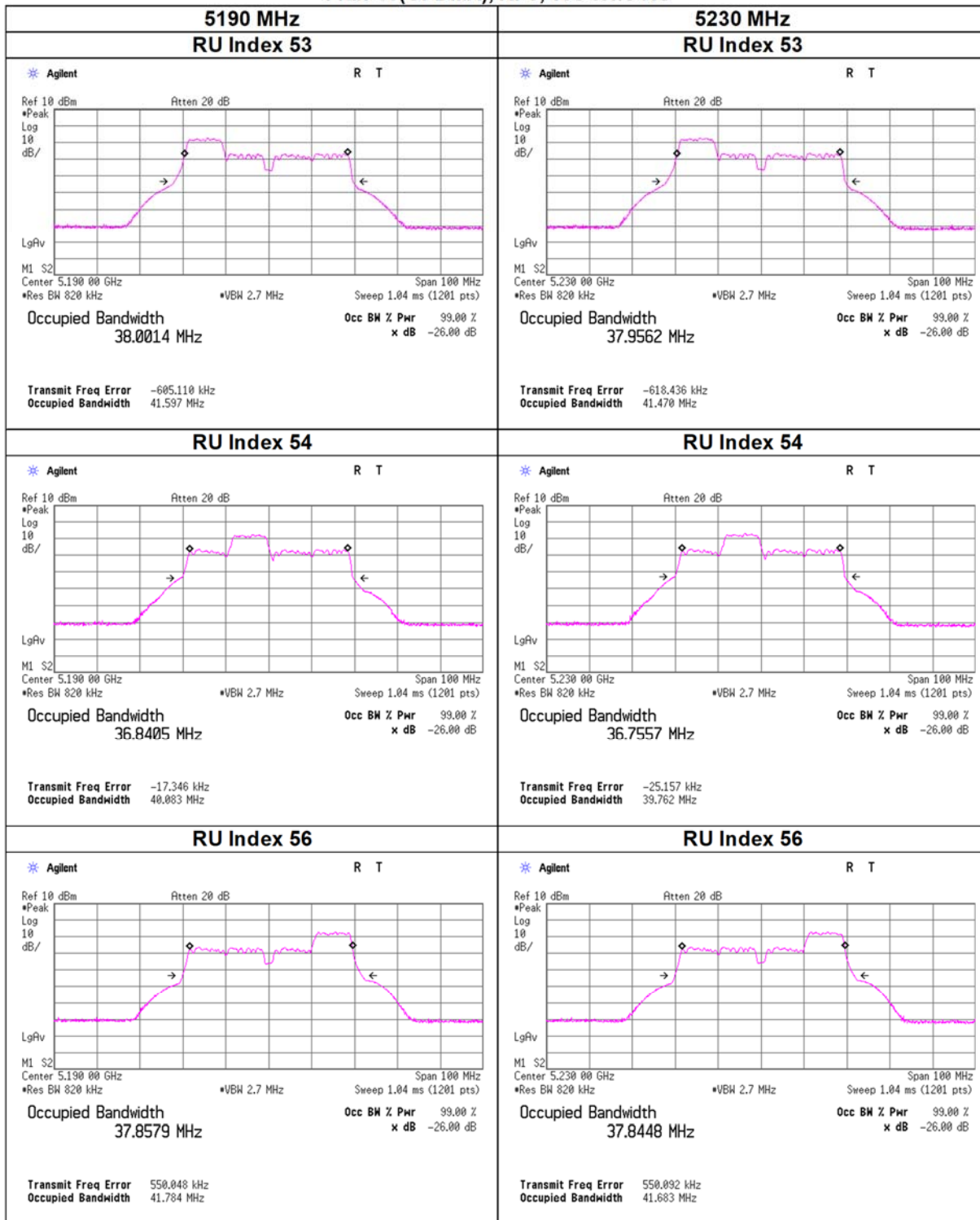

99 % Occupied Bandwidth

11ax-40(OFDMA), RF0, 106-tone RU

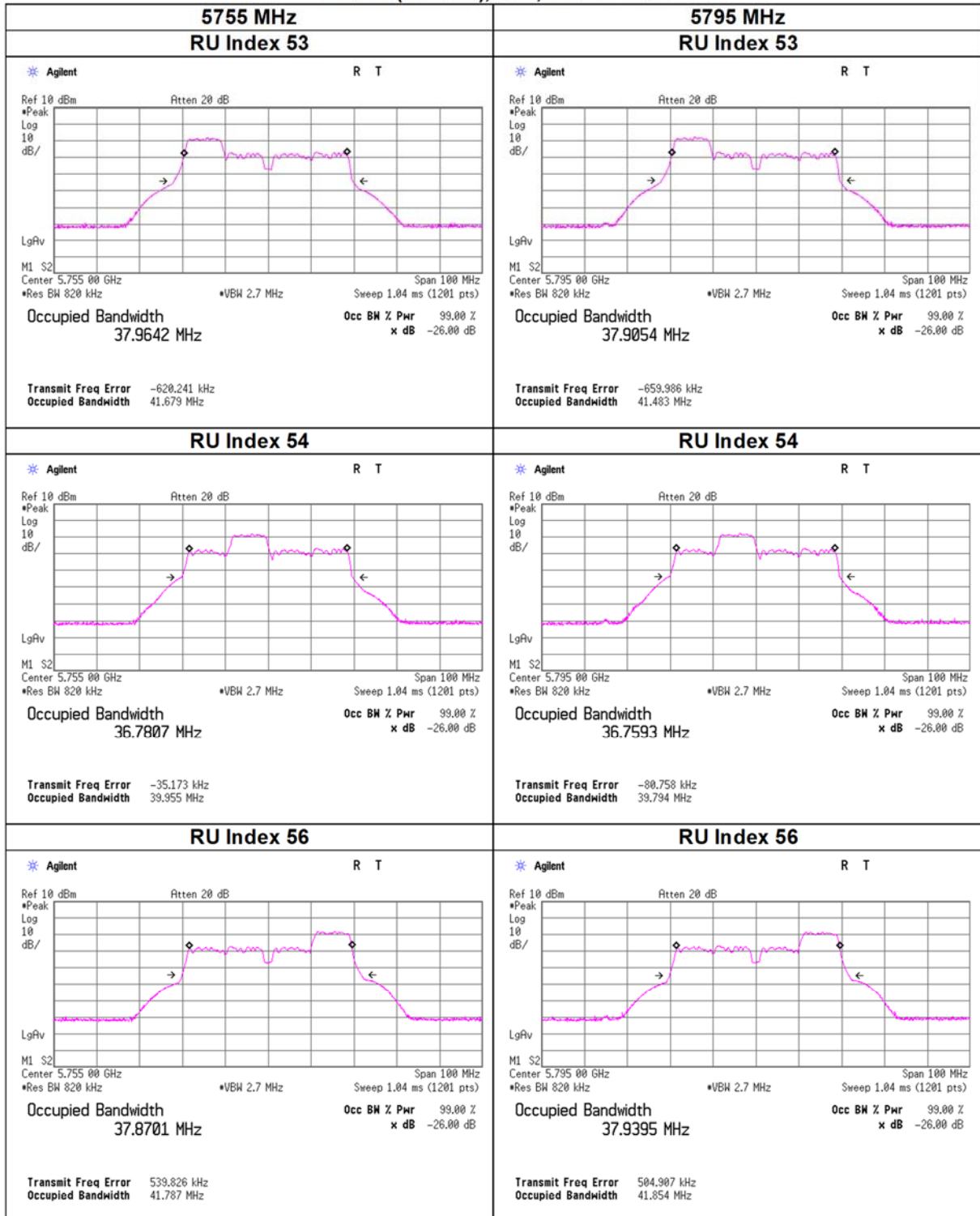

99 % Occupied Bandwidth

11ax-40(OFDMA), RF0, 242-tone RU

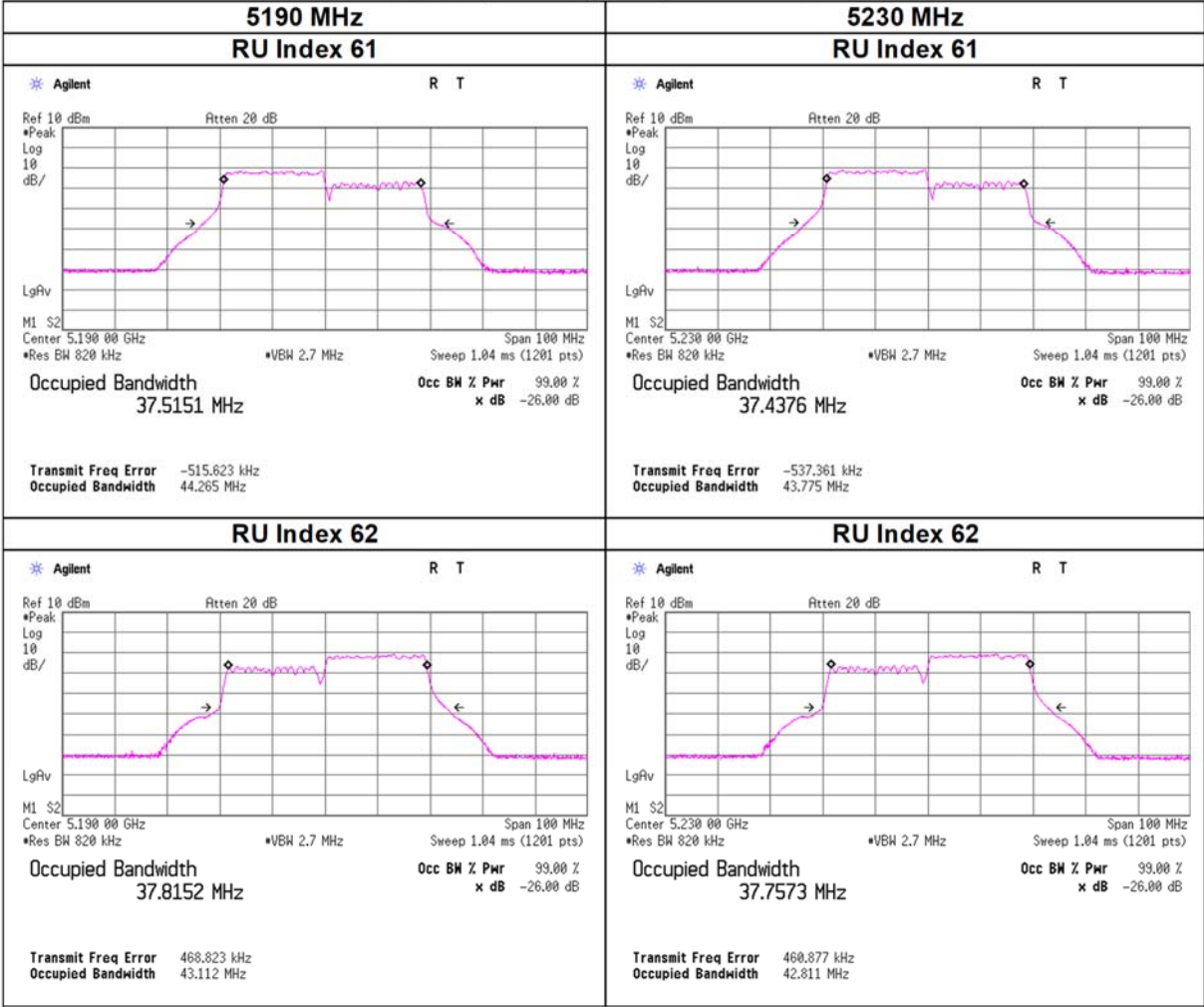

99 % Occupied Bandwidth

11ax-40(OFDMA), RF0, 242-tone RU

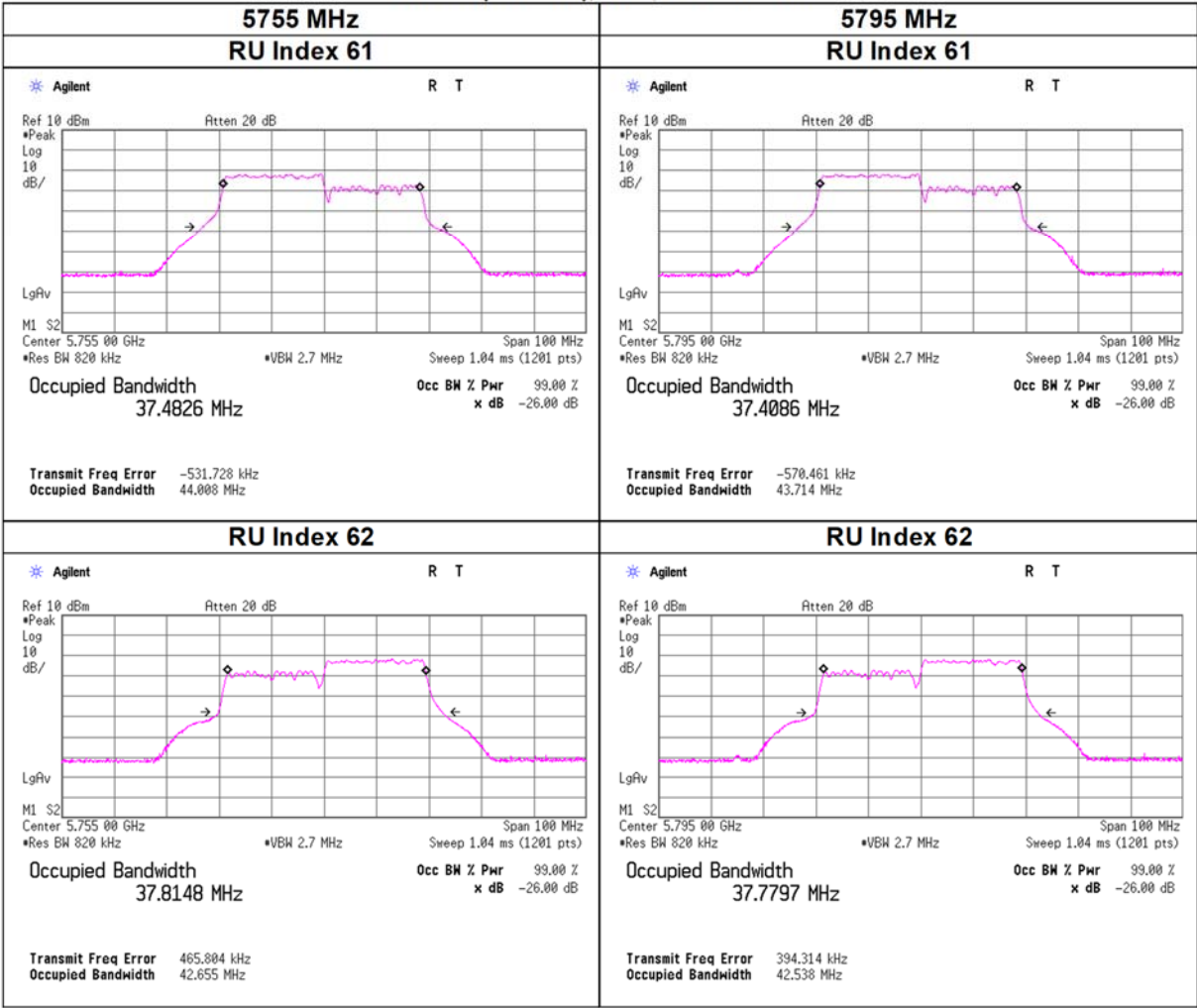

99 % Occupied Bandwidth

11ax-40(OFDMA), RF0, 484-tone RU

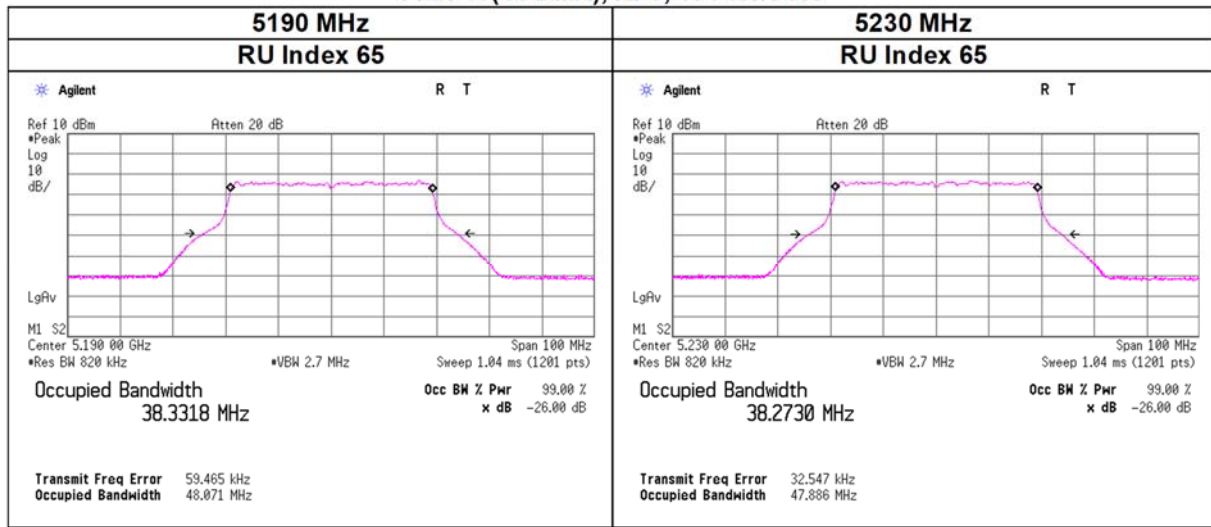

11ax-40(OFDMA), RF0, 484-tone RU

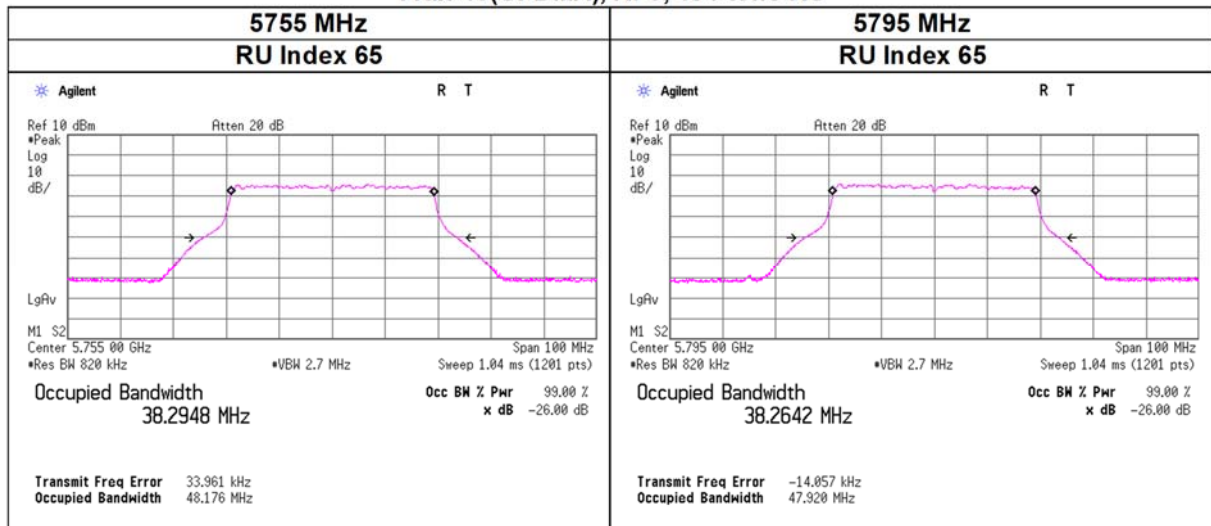

99 % Occupied Bandwidth

11ac-80, RF0

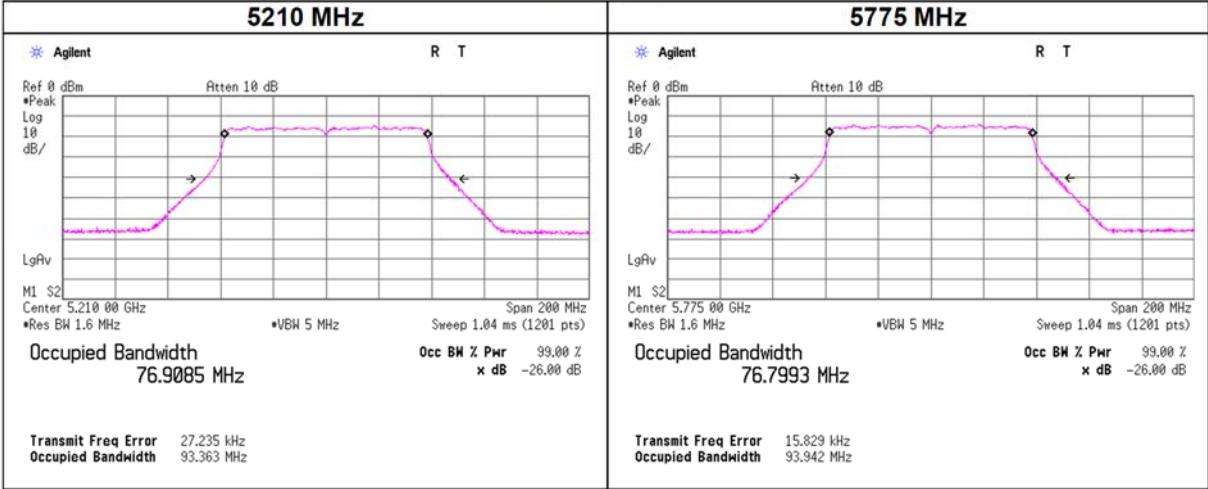

11ax-80 (OFDM), RF0

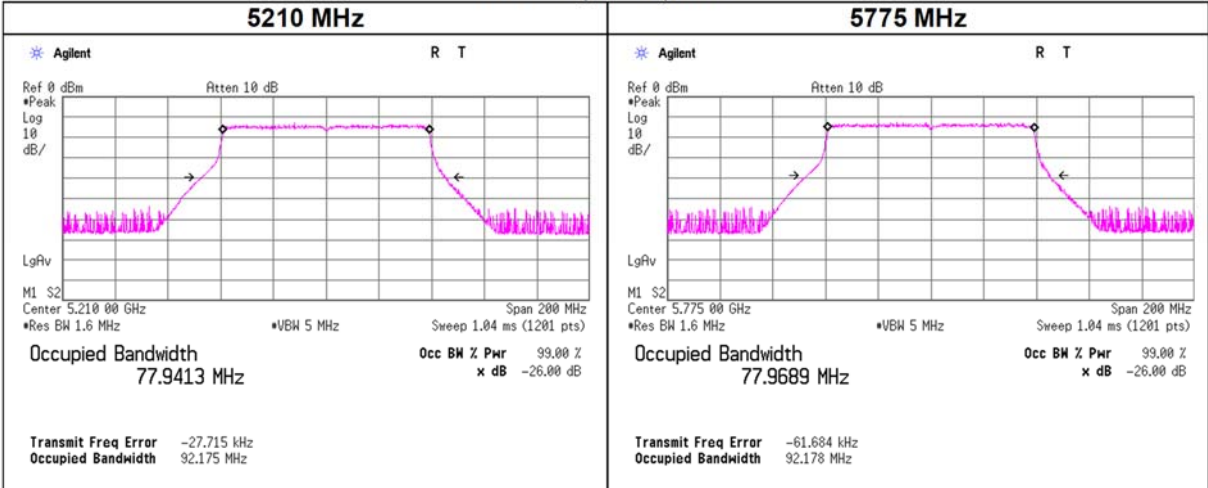

99 % Occupied Bandwidth

11ax-80(OFDMA), RF0, 26-tone RU

