





# RADIO TEST REPORT

## Test Report No. 15383304S-A

Customer	Panasonic Automotive Systems Co., Ltd.
Description of EUT	Car Navigation
Model Number of EUT	AT2402
FCC ID	ACJ932AT2402
Test Regulation	FCC Part 15 Subpart C
Test Result	Complied
Issue Date	October 25, 2024
Remarks	Bluetooth (BR / EDR) parts Maximum Peak Output Power only *Spot check

<b>Representative Test Engineer</b>	<b>Approved By</b>
	
Miku Ikudome Engineer	Shinichi Takano Engineer
 	
CERTIFICATE 1266.03	
<input type="checkbox"/> The testing in which "Non-accreditation" is displayed is outside the accreditation scopes in UL Japan, Inc.	
<input checked="" type="checkbox"/> There is no testing item of "Non-accreditation".	

Report Cover Page - Form-ULID-003532 (DCS:13-EM-F0429) Issue# 23.0

---

## **ANNOUNCEMENT**

- This test report shall not be reproduced in full or partial, without the written approval of UL Japan, Inc.
- The results in this report apply only to the sample tested. (Laboratory was not involved in sampling.)
- This sample tested is in compliance with the limits of the above regulation.
- The test results in this test report are traceable to the national or international standards.
- This test report must not be used by the customer to claim product certification, approval, or endorsement by the A2LA accreditation body.
- This test report covers Radio technical requirements.  
It does not cover administrative issues such as Manual or non-Radio test related Requirements. (if applicable)
- The all test items in this test report are conducted by UL Japan, Inc. Shonan EMC Lab.
- The opinions and the interpretations to the result of the description in this report are outside scopes where UL Japan, Inc. has been accredited.
- The information provided by the customer for this report is identified in SECTION 1.
- The laboratory is not responsible for information provided by the customer which can impact the validity of the results.
- For test report(s) referred in this report, the latest version (including any revisions) is always referred.

## **REVISION HISTORY**

**Original Test Report No.: 15383304S-A**

Revision	Test Report No.	Date	Page Revised Contents
- (Original)	15383304S-A	October 25, 2024	-

**Reference: Abbreviations (Including words undescribed in this report)**

A2LA	The American Association for Laboratory Accreditation	IEC	International Electrotechnical Commission
AC	Alternating Current	IEEE	Institute of Electrical and Electronics Engineers
AFH	Adaptive Frequency Hopping	IF	Intermediate Frequency
AM	Amplitude Modulation	ILAC	International Laboratory Accreditation Conference
Amp, AMP	Amplifier	ISED	Innovation, Science and Economic Development Canada
ANSI	American National Standards Institute	ISO	International Organization for Standardization
Ant, ANT	Antenna	JAB	Japan Accreditation Board
AP	Access Point	LAN	Local Area Network
ASK	Amplitude Shift Keying	LIMS	Laboratory Information Management System
Atten., ATT	Attenuator	MCS	Modulation and Coding Scheme
AV	Average	MRA	Mutual Recognition Arrangement
BPSK	Binary Phase-Shift Keying	N/A	Not Applicable
BR	Bluetooth Basic Rate	NIST	National Institute of Standards and Technology
BT	Bluetooth	NS	No signal detect.
BT LE	Bluetooth Low Energy	NSA	Normalized Site Attenuation
BW	BandWidth	NVLAP	National Voluntary Laboratory Accreditation Program
Cal Int	Calibration Interval	OBW	Occupied Band Width
CCK	Complementary Code Keying	OFDM	Orthogonal Frequency Division Multiplexing
Ch., CH	Channel	OFDMA	Orthogonal Frequency Division Multiple Access
CISPR	Comite International Special des Perturbations Radioelectriques	P/M	Power meter
CW	Continuous Wave	PCB	Printed Circuit Board
DBPSK	Differential BPSK	PER	Packet Error Rate
DC	Direct Current	PHY	Physical Layer
D-factor	Distance factor	PK	Peak
DFS	Dynamic Frequency Selection	PN	Pseudo random Noise
DQPSK	Differential QPSK	PP	Preamble Puncturing
DSSS	Direct Sequence Spread Spectrum	PRBS	Pseudo-Random Bit Sequence
EDR	Enhanced Data Rate	PSD	Power Spectral Density
EIRP, e.i.r.p.	Equivalent Isotropically Radiated Power	QAM	Quadrature Amplitude Modulation
EMC	ElectroMagnetic Compatibility	QP	Quasi-Peak
EMI	ElectroMagnetic Interference	QPSK	Quadri-Phase Shift Keying
EN	European Norm	RBW	Resolution Band Width
ERP, e.r.p.	Effective Radiated Power	RDS	Radio Data System
EU	European Union	RE	Radio Equipment
EUT	Equipment Under Test	RF	Radio Frequency
Fac.	Factor	RMS	Root Mean Square
FCC	Federal Communications Commission	RSS	Radio Standards Specifications
FHSS	Frequency Hopping Spread Spectrum	Rx	Receiving
FM	Frequency Modulation	SA, S/A	Spectrum Analyzer
Freq.	Frequency	SG	Signal Generator
FSK	Frequency Shift Keying	SVSWR	Site-Voltage Standing Wave Ratio
GFSK	Gaussian Frequency-Shift Keying	TR	Test Receiver
GNSS	Global Navigation Satellite System	Tx	Transmitting
GPS	Global Positioning System	VBW	Video BandWidth
Hori.	Horizontal	Vert.	Vertical
ICES	Interference-Causing Equipment Standard	WLAN	Wireless LAN

---

<b>CONTENTS</b>	<b>PAGE</b>
<b>SECTION 1: Customer Information .....</b>	<b>5</b>
<b>SECTION 2: Equipment Under Test (EUT).....</b>	<b>5</b>
<b>SECTION 3: Test Specification, Procedures &amp; Results .....</b>	<b>7</b>
<b>SECTION 4: Operation of EUT during testing .....</b>	<b>9</b>
<b>SECTION 5: Antenna Terminal Conducted Tests .....</b>	<b>11</b>
<b>APPENDIX 1: Test data .....</b>	<b>12</b>
Maximum Peak Output Power .....	12
<b>APPENDIX 2: Test Instruments .....</b>	<b>13</b>
<b>APPENDIX 3: Photographs of test setup.....</b>	<b>14</b>
Antenna Terminal Conducted Tests .....	14

## **SECTION 1: Customer Information**

Company Name	Panasonic Automotive Systems Co., Ltd. *1)
Address	4261, Ikonobe-cho, Tsuzuki-ku, Yokohama-shi, Kanagawa-ken 224-8520, Japan
Telephone Number	+81-90-8513-8335
Contact Person	Daisuke Takahata

\*1) The Grantee name in the FCC application is "Panasonic Corporation of North America".

The information provided by the customer is as follows;

- Customer, Description of EUT, Model Number of EUT, FCC ID on the cover and other relevant pages
- Operating/Test Mode(s) (Mode(s)) on all the relevant pages
- SECTION 1: Customer Information
- SECTION 2: Equipment Under Test (EUT) other than the Receipt Date and Test Date
- SECTION 4: Operation of EUT during testing

## **SECTION 2: Equipment Under Test (EUT)**

### **2.1 Identification of EUT**

Description	Car Navigation
Model Number	AT2402
Serial Number	Refer to SECTION 4.2
Condition	Production prototype (Not for Sale: This sample is equivalent to mass-produced items.)
Modification	No Modification by the test lab
Receipt Date	June 27, 2024
Test Date	July 27, 2024

### **2.2 Product Description**

#### **General Specification**

Rating	DC 13.2 V
Operating temperature	-30 deg. C to +65 deg. C

## Radio Specification

This report contains data provided by the customer which can impact the validity of results. UL Japan, Inc. is only responsible for the validity of results after the integration of the data provided by the customer. The data provided by the customer is marked "a)" in the table below.

### Bluetooth (BR / EDR / BT LE)

Equipment Type	Transceiver
Frequency of Operation	2402 MHz to 2480 MHz
Type of Modulation	FHSS, GFSK / $\pi/4$ -DQPSK, 8DPSK / GFSK
Antenna Gain <sup>a)</sup>	4 dBi

### WLAN (IEEE802.11b/11g/11n-20/11ax-20)

Equipment Type	Transceiver
Frequency of Operation	2412 MHz to 2462 MHz
Type of Modulation	DSSS, OFDM OFDMA: (20 MHz band): 26/52/106/242-tone RU
Antenna Gain <sup>a)</sup>	4 dBi

### WLAN (IEEE802.11a/11n-20/11ac-20/11ax-20/11n-40/11ac-40/11ax-40/11ac-80/11ax-80)

Equipment Type	Transceiver	
Frequency of Operation	20 MHz Band	5180 MHz to 5240 MHz 5745 MHz to 5825 MHz
	40 MHz Band	5190 MHz to 5230 MHz 5755 MHz to 5795 MHz
	80 MHz Band	5210 MHz, 5775 MHz
Type of Modulation	OFDM	
	OFDMA (IEEE802.11ax only)	(20 MHz band): 26/52/106/242-tone RU
		(40 MHz band): 26/52/106/242/484-tone RU
(80 MHz band): 26/52/106/242/484/996-tone RU		
Antenna Gain <sup>a)</sup>	RF0: 5 dBi, RF1: 5 dBi	

## 2.3 Variant Models

CK-BT2EM0AJ, CK-BT2EA0AJ, CK-BT2EN6AJ, CK-BT2EN7AJ, CK-BT2EN4LX, CK-BT2EN5LX

## SECTION 3: Test Specification, Procedures & Results

### 3.1 Test Specification

Test Specification	FCC Part 15 Subpart C The latest version on the first day of the testing period
Title	FCC 47 CFR Part 15 Radio Frequency Device Subpart C Intentional Radiators Section 15.207 Conducted limits Section 15.247 Operation within the bands 902-928 MHz, 2400-2483.5 MHz, and 5725-5850 MHz

### 3.2 Procedures and Results

Item	Test Procedure	Specification	Worst Margin	Results	Remarks
Maximum Peak Output Power	FCC: KDB 558074 D01 15.247 Meas Guidance v05r02 ISED: RSS-Gen 6.12	FCC: Section15.247(b)(1) ISED: RSS-247 5.4 (b)	See data	Complied	Conducted
Note: UL Japan, Inc.'s EMI Work Procedures: Work Instructions-ULID-003591 and Work Instructions-ULID-003593. * In case any questions arise about test procedure, ANSI C63.10: 2013 is also referred.					

#### **FCC Part 15.31 (e)**

This EUT provides the stable voltage constantly to RF part regardless of input voltage. Therefore, this EUT complies with the requirement.

#### **FCC Part 15.203 Antenna requirement**

It is impossible for end users to replace the antenna, because the antenna is mounted inside of the EUT. Therefore, the equipment complies with the antenna requirement of Section 15.203.

### 3.3 Addition to Standard

No addition, exclusion nor deviation has been made from the standard.

### 3.4 Uncertainty

Measurement uncertainty is not taken into account when stating conformity with a specified requirement. Note: When margins obtained from test results are less than the measurement uncertainty, the test results may exceed the limit.

The following uncertainties have been calculated to provide a confidence level of 95 % using a coverage factor  $k = 2$ .

Antenna terminal test	Uncertainty (+/-)
Power Measurement above 1 GHz (Average Detector)	1.3 dB
Power Measurement above 1 GHz (Peak Detector)	1.8 dB
Spurious Emission (Conducted) below 1 GHz	0.91 dB
Conducted Emissions Power Density Measurement 1 GHz to 3 GHz	1.3 dB
Conducted Emissions Power Density Measurement 3 GHz to 18 GHz	2.5 dB
Spurious Emission (Conducted) 18 GHz to 26.5 GHz	2.8 dB
Spurious Emission (Conducted) 26.5 GHz to 40 GHz	2.6 dB
Bandwidth Measurement	0.012 %
Duty Cycle and Time Measurement	0.27 %
Temperature	2.2 deg.C.
Humidity	4.0 %
Voltage	0.74 %

### 3.5 Test Location

UL Japan, Inc. Shonan EMC Lab.

1-22-3, Megumigaoka, Hiratsuka-shi, Kanagawa-ken 259-1220 Japan

Telephone: +81-463-50-6400

A2LA Certificate Number: 1266.03

(FCC test firm registration number: 626366, ISED lab company number: 2973D / CAB identifier: JP0001)

Test room	Width x Depth x Height (m)	Size of reference ground plane (m) / horizontal conducting plane	Maximum measurement distance
No.1 Semi-anechoic chamber (SAC1)	20.6 x 11.3 x 7.65	20.6 x 11.3	10 m
No.2 Semi-anechoic chamber (SAC2)	20.6 x 11.3 x 7.65	20.6 x 11.3	10 m
No.3 Semi-anechoic chamber (SAC3)	12.7 x 7.7 x 5.35	12.7 x 7.7	5 m
No.4 Semi-anechoic chamber (SAC4)	8.1 x 5.1 x 3.55	8.1 x 5.1	-
Wireless anechoic chamber 1 (WAC1)	9.5 x 6.0 x 5.4	9.5 x 6.0	3 m
Wireless anechoic chamber 2 (WAC2)	9.5 x 6.0 x 5.4	9.5 x 6.0	3 m
No.1 Shielded room	6.8 x 4.1 x 2.7	6.8 x 4.1	-
No.2 Shielded room	6.8 x 4.1 x 2.7	6.8 x 4.1	-
No.3 Shielded room	6.3 x 4.7 x 2.7	6.3 x 4.7	-
No.4 Shielded room	4.4 x 4.7 x 2.7	4.4 x 4.7	-
No.5 Shielded room	7.8 x 6.4 x 2.7	7.8 x 6.4	-
No.6 Shielded room	7.8 x 6.4 x 2.7	7.8 x 6.4	-
No.8 Shielded room	3.45 x 5.5 x 2.4	3.45 x 5.5	-
No.1 Measurement room	2.55 x 4.1 x 2.5	-	-
No.2 Measurement room	4.5 x 3.5 x 2.5	-	-
Wireless shielded room 1	3.0 x 4.5 x 2.7	3.0 x 4.5	-
Wireless shielded room 2	3.0 x 4.5 x 2.7	3.0 x 4.5	-

### 3.6 Test Data, Test Instruments, and Test Set Up

Refer to APPENDIX.

## **SECTION 4: Operation of EUT during testing**

### **4.1 Operating Mode(s)**

<b>Mode</b>	<b>Remarks*</b>
Bluetooth (BT)	BR / EDR, Payload: PRBS9
*Duty Factor referenced the original report. (Reference test report No.: 14747914S-A)	
*EUT has the power settings by the software as follows; Power Setting: 9 (Setting Value) Software: bluetooth_serial Version: 3 (Date: 2023.04.18, Storage location: Driven by connected PC)	
*This setting of software is the worst case. Any conditions under the normal use do not exceed the condition of setting. In addition, end users cannot change the settings of the output power of the product.	

#### Details of Operating Mode(s)

<b>Test Item</b>	<b>Mode</b>	<b>Hopping</b>	<b>Tested Frequency</b>
Maximum Peak Output Power	Tx DH5 Tx 2DH5 Tx 3DH5	Off	2402 MHz 2441 MHz 2480 MHz
*As a result of preliminary test, the formal test was performed with the above modes, which had the maximum payload length (except Dwell time test) *It is considered that the non-tested packet type (e.g. inquiry) can be omitted as it is complied with above all the test items based on Bluetooth Core specification.			

## 4.2 Configuration and Peripherals

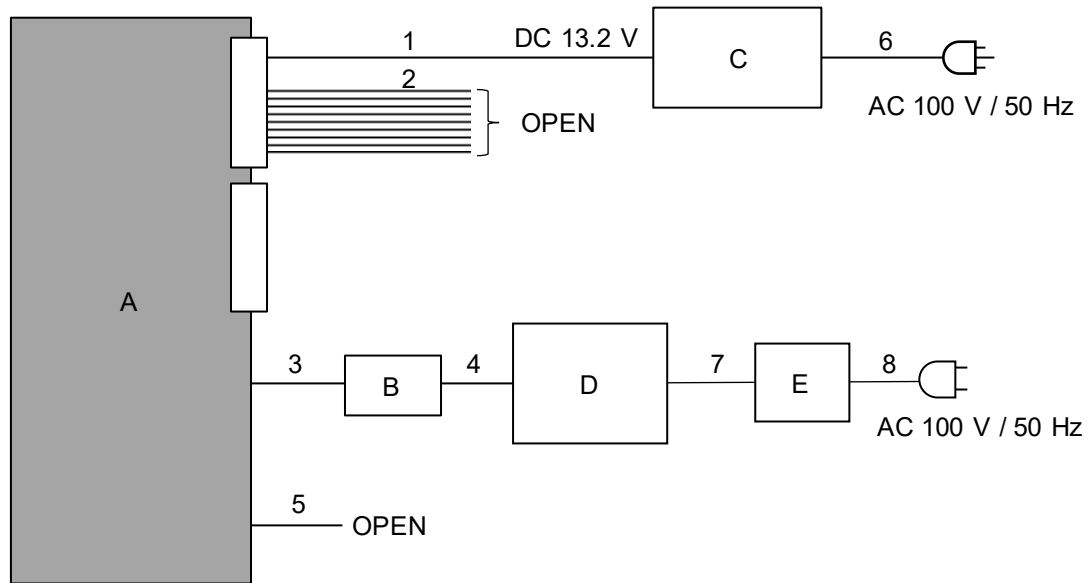

### Description of EUT and Support Equipment

No.	Item	Model number	Serial Number	Manufacturer	Remarks
A	Car Navigation	AT2402	500069	Panasonic	EUT
B	Jig Board	-	-	-	-
C	Power Supply(DC)	SPI008	-	GOODGOODS	-
D	Laptop Computer	ThinkPad E14 Gen2	PF397TQG	LENOVO	-
E	AC Adapter	ADLX65YCC2D	8SSA10R16922 C2TJ19M1368	LENOVO	-

### List of Cables Used

No.	Name	Length (m)	Shield		Remarks
			Cable	Connector	
1	DC	3.0 + 1.0	Unshielded	Unshielded	-
2	Signal	3.0	Unshielded	Unshielded	-
3	Signal	0.1	Unshielded	Unshielded	-
4	USB	1.0 + 2.0	Shielded	Shielded	-
5	Signal	0.1	Unshielded	Unshielded	-
6	AC	2.0	Unshielded	Unshielded	-
7	DC	1.8	Unshielded	Unshielded	-
8	AC	0.9	Unshielded	Unshielded	-

---

## **SECTION 5: Antenna Terminal Conducted Tests**

### **Test Procedure**

The tests were made with below setting connected to the antenna port.

Test	Span	RBW	VBW	Sweep time	Detector	Trace	Instrument Used
Maximum Peak Output Power	-	-	-	Auto	Peak/ Average *1)	-	Power Meter (Sensor: 160 MHz BW)

\*1) Reference data

Test results are rounded off and limit are rounded down, so some differences might be observed.  
The equipment and cables were not used for factor 0 dB of the data sheets.

**Test Data** : **APPENDIX**

**Test Result** : **Pass**

## APPENDIX 1: Test data

### Maximum Peak Output Power

Test place Shonan EMC Lab. No.5 Shielded Room  
Date July 27, 2024  
Temperature / Humidity 25 deg. C / 40 % RH  
Engineer Miku Ikudome  
Mode Tx, Hopping Off

#### Maximum peak output power

Mode	Freq. [MHz]	Reading [dBm]	Cable Loss [dB]	Atten. Loss [dB]	Conducted Power					e.i.r.p. for RSS-247					
					Result		Limit		Margin [dB]	Antenna Gain [dBi]	Result		Limit		Margin [dB]
					[dBm]	[mW]	[dBm]	[mW]			[dBm]	[mW]	[dBm]	[mW]	
DH5	2402	-7.05	2.28	10.05	5.28	3.37	20.97	125	15.69	4.00	9.28	8.47	36.02	4000	26.74
DH5	2441	-7.29	2.29	10.05	5.05	3.20	20.97	125	15.92	4.00	9.05	8.04	36.02	4000	26.97
DH5	2480	-7.12	2.31	10.05	5.24	3.34	20.97	125	15.73	4.00	9.24	8.39	36.02	4000	26.78
2DH5	2402	-5.50	2.28	10.05	6.83	4.82	20.97	125	14.14	4.00	10.83	12.11	36.02	4000	25.19
2DH5	2441	-5.80	2.29	10.05	6.54	4.51	20.97	125	14.43	4.00	10.54	11.32	36.02	4000	25.48
2DH5	2480	-5.64	2.31	10.05	6.72	4.70	20.97	125	14.25	4.00	10.72	11.80	36.02	4000	25.30
3DH5	2402	-5.14	2.28	10.05	7.19	5.24	20.97	125	13.78	4.00	11.19	13.15	36.02	4000	24.83
3DH5	2441	-5.28	2.29	10.05	7.06	5.08	20.97	125	13.91	4.00	11.06	12.76	36.02	4000	24.96
3DH5	2480	-5.22	2.31	10.05	7.14	5.18	20.97	125	13.83	4.00	11.14	13.00	36.02	4000	24.88

Sample Calculation:

Result = Reading + Cable Loss (including the cable(s) customer supplied) + Attenuator Loss

e.i.r.p. Result = Conducted Power Result + Antenna Gain

Test was not performed at AFH mode, because the decrease of number of channel (min: 20 ch) at AFH mode does not influence on the output power and bandwidth of the EUT.

As this device had AFH mode and frequency separation could not meet the requirement of over 20 dB BW without 2/3 relaxation, 125 mW power limit was applied to it.

#### Average power (Reference data for RF Exposure / SAR testing)

Mode	Freq. [MHz]	Reading [dBm]	Cable Loss [dB]	Atten. Loss [dB]	Result (Time average)		Duty factor [dB]	Result (Burst power average)	
					[dBm]	[mW]		[dBm]	[mW]
					DH5	2402	-8.51	2.28	10.05
DH5	2441	-8.80	2.29	10.05	3.54	2.26	1.09	4.63	2.91
DH5	2480	-8.66	2.31	10.05	3.70	2.34	1.09	4.79	3.01
2DH5	2402	-8.99	2.28	10.05	3.34	2.16	1.09	4.43	2.78
2DH5	2441	-9.31	2.29	10.05	3.03	2.01	1.09	4.12	2.58
2DH5	2480	-9.13	2.31	10.05	3.23	2.10	1.09	4.32	2.71
3DH5	2402	-9.00	2.28	10.05	3.33	2.15	1.09	4.42	2.77
3DH5	2441	-9.28	2.29	10.05	3.06	2.02	1.09	4.15	2.60
3DH5	2480	-9.11	2.31	10.05	3.25	2.11	1.09	4.34	2.72

Sample Calculation:

Result (Time average) = Reading + Cable Loss (including the cable(s) customer supplied) + Attenuator Loss

Result (Burst power average) = Result (Time average) + Duty factor

## **APPENDIX 2: Test Instruments**

### **Test Equipment**

<b>Test Item</b>	<b>LIMS ID</b>	<b>Description</b>	<b>Manufacturer</b>	<b>Model</b>	<b>Serial</b>	<b>Last Calibration Date</b>	<b>Cal Int</b>
AT	146212	Digital Hitester	HIOKI E.E. CORPORATION	3805-50	80997828	2023/09/25	12
AT	146247	Power Meter	Keysight Technologies Inc	8990B	MY51000272	2024/05/14	12
AT	146310	Power sensor	Keysight Technologies Inc	N1923A	MY5326009	2024/05/14	12
AT	191845	Thermo-Hygrometer	CUSTOM. Inc	CTH-201	-	2023/08/07	12
AT	204926	Attenuator	Weinschel Corp.	54A-10	109971	2024/02/14	12
AT	239652	Coaxial Cable	Huber+Suhner	SUCOFLEX 102	2001220/2	2023/08/22	12

**\*Hyphens for Last Calibration Date and Cal Int (month) are instruments that Calibration is not required (e.g. software), or instruments checked in advance before use.**

**The expiration date of the calibration is the end of the expired month.**

**As for some calibrations performed after the tested dates, those test equipment have been controlled by means of an unbroken chains of calibrations.**

**All equipment is calibrated with valid calibrations. Each measurement data is traceable to the national or international standards.**

**Test item:**

**AT: Antenna Terminal Conducted test**