



# EMI TEST REPORT

**Test Report No. : 13226969H-A-R1**

**Applicant** : **Panasonic Corporation**  
**Type of EUT** : **Wireless Charger**  
**Model Number of EUT** : **AT2001**  
**FCC ID** : **ACJ932AT2001**  
**Test regulation** : **FCC Part 18: 2017**  
**Test Result** : **Complied (Refer to SECTION 3.2)**

1. This test report shall not be reproduced in full or partial, without the written approval of UL Japan, Inc.
2. The results in this report apply only to the sample tested.
3. This sample tested is in compliance with the limits of the above regulation.
4. The test results in this test report are traceable to the national or international standards.
5. This test report covers EMC technical requirements.  
It does not cover administrative issues such as Manual or non-EMC test related Requirements. (if applicable)
6. The all test items in this test report are conducted by UL Japan, Inc. Ise EMC Lab.
7. The opinions and the interpretations to the result of the description in this report are outside scopes where UL Japan has been accredited.
8. The information provided from the customer for this report is identified in SECTION 1.
9. This report is a revised version of 13226969H-A. 13226969H-A is replaced with this report.

**Date of test:** March 31 to May 2, 2020

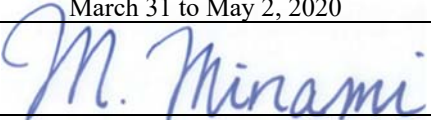
**Representative test engineer:**   
Masaya Minami  
Engineer  
Consumer Technology Division

**Approved by:**   
Tsubasa Takayama  
Leader  
Consumer Technology Division



- The testing in which "Non-accreditation" is displayed is outside the accreditation scopes in UL Japan.  
 There is no testing item of "Non-accreditation".

**UL Japan, Inc.**  
**Ise EMC Lab.**

4383-326 Asama-cho, Ise-shi, Mie-ken 516-0021 JAPAN  
Telephone : +81 596 24 8999  
Facsimile : +81 596 24 8124

## **REVISION HISTORY**

### **Original Test Report No.: 13226969H-A**

Revision	Test report No.	Date	Page revised	Contents
- (Original)	13226969H-A	May 18, 2020	-	-
1	13226969H-A-R1	June 11, 2020	P.5	Correction of Operating Frequency in Radio Specification of Clause 2.2; From 127.5 kHz To 120.3 kHz / 127.0 kHz / 127.5 kHz / 126.515 kHz to 128.549 kHz
1	13226969H-A-R1	June 11, 2020	P.5	Deletion of Frequency Band from Radio Specification of Clause 2.2.

---

**UL Japan, Inc.**

**Ise EMC Lab.**

4383-326 Asama-cho, Ise-shi, Mie-ken 516-0021 JAPAN

Telephone : +81 596 24 8999

Facsimile : +81 596 24 8124

## Reference: Abbreviations (Including words undescribed in this report)

A2LA	The American Association for Laboratory Accreditation	MCS	Modulation and Coding Scheme
AC	Alternating Current	MRA	Mutual Recognition Arrangement
AFH	Adaptive Frequency Hopping	N/A	Not Applicable
AM	Amplitude Modulation	NIST	National Institute of Standards and Technology
Amp, AMP	Amplifier	NS	No signal detect.
ANSI	American National Standards Institute	NSA	Normalized Site Attenuation
Ant, ANT	Antenna	NVLAP	National Voluntary Laboratory Accreditation Program
AP	Access Point	OBW	Occupied Band Width
ASK	Amplitude Shift Keying	OFDM	Orthogonal Frequency Division Multiplexing
Atten., ATT	Attenuator	P/M	Power meter
AV	Average	PCB	Printed Circuit Board
BPSK	Binary Phase-Shift Keying	PER	Packet Error Rate
BR	Bluetooth Basic Rate	PHY	Physical Layer
BT	Bluetooth	PK	Peak
BT LE	Bluetooth Low Energy	PN	Pseudo random Noise
BW	BandWidth	PRBS	Pseudo-Random Bit Sequence
Cal Int	Calibration Interval	PSD	Power Spectral Density
CCK	Complementary Code Keying	QAM	Quadrature Amplitude Modulation
Ch., CH	Channel	QP	Quasi-Peak
CISPR	Comite International Special des Perturbations Radioelectriques	QPSK	Quadri-Phase Shift Keying
CW	Continuous Wave	RBW	Resolution Band Width
DBPSK	Differential BPSK	RDS	Radio Data System
DC	Direct Current	RE	Radio Equipment
D-factor	Distance factor	RF	Radio Frequency
DFS	Dynamic Frequency Selection	RMS	Root Mean Square
DQPSK	Differential QPSK	RSS	Radio Standards Specifications
DSSS	Direct Sequence Spread Spectrum	Rx	Receiving
EDR	Enhanced Data Rate	SA, S/A	Spectrum Analyzer
EIRP, e.i.r.p.	Equivalent Isotropically Radiated Power	SG	Signal Generator
EMC	ElectroMagnetic Compatibility	SVSWR	Site-Voltage Standing Wave Ratio
EMI	ElectroMagnetic Interference	TR	Test Receiver
EN	European Norm	Tx	Transmitting
ERP, e.r.p.	Effective Radiated Power	VBW	Video BandWidth
EU	European Union	Vert.	Vertical
EUT	Equipment Under Test	WLAN	Wireless LAN
Fac.	Factor		
FCC	Federal Communications Commission		
FHSS	Frequency Hopping Spread Spectrum		
FM	Frequency Modulation		
Freq.	Frequency		
FSK	Frequency Shift Keying		
GFSK	Gaussian Frequency-Shift Keying		
GNSS	Global Navigation Satellite System		
GPS	Global Positioning System		
Hori.	Horizontal		
ICES	Interference-Causing Equipment Standard		
IEC	International Electrotechnical Commission		
IEEE	Institute of Electrical and Electronics Engineers		
IF	Intermediate Frequency		
ILAC	International Laboratory Accreditation Conference		
ISED	Innovation, Science and Economic Development Canada		
ISO	International Organization for Standardization		
JAB	Japan Accreditation Board		
LAN	Local Area Network		
LIMS	Laboratory Information Management System		

**UL Japan, Inc.**

**Ise EMC Lab.**

4383-326 Asama-cho, Ise-shi, Mie-ken 516-0021 JAPAN

Telephone : +81 596 24 8999

Facsimile : +81 596 24 8124

<b>CONTENTS</b>	<b>PAGE</b>
<b>SECTION 1: Customer information .....</b>	<b>5</b>
<b>SECTION 2: Equipment under test (EUT) .....</b>	<b>5</b>
<b>SECTION 3: Test specification, procedures &amp; results .....</b>	<b>6</b>
<b>SECTION 4: Operation of EUT during testing.....</b>	<b>8</b>
<b>SECTION 5: Radiated Emission .....</b>	<b>10</b>
<b>APPENDIX 1: Test data .....</b>	<b>13</b>
<b>Radiated Emission.....</b>	<b>13</b>
<b>APPENDIX 2: Test instruments .....</b>	<b>35</b>
<b>APPENDIX 3: Photographs of test setup.....</b>	<b>36</b>
<b>Radiated Emission.....</b>	<b>36</b>
<b>Worst Case Position .....</b>	<b>40</b>

## **SECTION 1: Customer information**

Company Name : Panasonic Corporation  
Address : 4261, Ikonobe-cho, Tsuzuki-ku, Yokohama-shi, Kanagawa-ken, 224-8520,  
Japan  
Telephone Number : +81-50-3689-7112  
Facsimile Number : +81-45-931-0806  
Contact Person : Takahisa Sakai

The information provided from the customer is as follows;

- Applicant, Type of EUT, Model Number of EUT, FCC ID on the cover and other relevant pages
  - Operating/Test Mode(s) (Mode(s)) on all the relevant pages
  - SECTION 1: Customer information
  - SECTION 2: Equipment under test (EUT) other than the Receipt Date
  - SECTION 4: Operation of EUT. during testing
- \* The laboratory is exempted from liability of any test results affected from the above information in SECTION 2 and 4.

## **SECTION 2: Equipment under test (EUT)**

### **2.1 Identification of EUT**

Type : Wireless Charger  
Model Number : AT2001  
Serial Number : Refer to SECTION 4.2  
Rating : DC 10.5 V to 16.0 V  
Receipt Date : March 18, 2020  
Country of Mass-production : Japan, China, Czech Republic, and Thailand  
Condition : Production prototype  
(Not for Sale: This sample is equivalent to mass-produced items.)  
Modification : No Modification by the test lab.

### **2.2 Product Description**

Model: AT2001 (referred to as the EUT in this report) is a Wireless Charger.

Feature of EUT : Press the supply switch of the wireless charger. Each press the power supply switch it on/off.  
When turned the hybrid system off, the state of the power supply for wireless charger is memorized.  
Place the charging side of the portable device (etc. mobile phone) down.  
When charging, the operation indicator light (orange) comes on.  
If charging is not occurring, try placing the portable device as close to the center of the charging area as possible.  
When charging is complete, the operation indicator light (green) comes on.

### **Radio Specification**

Operating Frequency : 120.3 kHz / 127.0 kHz / 127.5 kHz / 126.515 kHz to 128.549 kHz  
Rated Output Power : 5 W / 10 W  
Coil system : Single Coil  
Charging distance : Contact  
Clock frequency (maximum) : 8 MHz

---

**UL Japan, Inc.**

**Ise EMC Lab.**

4383-326 Asama-cho, Ise-shi, Mie-ken 516-0021 JAPAN

Telephone : +81 596 24 8999

Facsimile : +81 596 24 8124

### **SECTION 3: Test specification, procedures & results**

#### **3.1 Test specification**

Test Specification : FCC Part 18 2017, final revised on November 2, 2017.  
 Title : FCC 47CFR Part18 Industrial, scientific, and medical equipment

#### **3.2 Procedures and results**

Item	Test Procedure & Limits	Deviation	Worst margin	Results	Remarks
Radiated emission	Section 18.305 FCC/OST MP-5	N/A	9.0 dB, 0.3841 MHz, Horizontal	Complied a)	-
Conducted emission	Section 18.307 FCC/OST MP-5	N/A	N/A	N/A	*1)
*Note: UL Japan, Inc.'s EMI Work Procedure 13-EM-W0420. *1) The test is not applicable since the EUT is not the device that is designed to be connected to the public utility (AC) power line.  a) Refer to APPENDIX 1 (data of Radiated emission)  Symbols: Complied The data of this test item has enough margin, more than the measurement uncertainty. Complied# The data of this test item meets the limits unless the measurement uncertainty is taken into consideration.					

#### **3.3 Addition to standard**

Other than above, no addition, exclusion nor deviation has been made from the standard.

#### **3.4 Uncertainty**

##### **EMI**

There is no applicable rule of uncertainty in this applied standard. Therefore, the following results are derived depending on whether or not laboratory uncertainty is applied.

The following uncertainties have been calculated to provide a confidence level of 95 % using a coverage factor  $k = 2$ .

##### **Radiated emission**

Measurement distance	Frequency range	Uncertainty (+/-)	
3 m	9 kHz to 30 MHz	3.3 dB	
10 m		3.2 dB	
3 m	30 MHz to 200 MHz	(Horizontal)	4.8 dB
		(Vertical)	5.0 dB
	200 MHz to 1000 MHz	(Horizontal)	5.2 dB
		(Vertical)	6.3 dB
10 m	30 MHz to 200 MHz	(Horizontal)	4.8 dB
		(Vertical)	4.8 dB
	200 MHz to 1000 MHz	(Horizontal)	5.0 dB
		(Vertical)	5.0 dB

**UL Japan, Inc.**

**Ise EMC Lab.**

4383-326 Asama-cho, Ise-shi, Mie-ken 516-0021 JAPAN

Telephone : +81 596 24 8999

Facsimile : +81 596 24 8124

### 3.5 Test Location

UL Japan, Inc. Ise EMC Lab.

\*NVLAP Lab. code: 200572-0 / FCC Test Firm Registration Number: 199967 / ISED Lab Company Number: 2973C

4383-326 Asama-cho, Ise-shi, Mie-ken 516-0021 JAPAN

Telephone: +81 596 24 8999, Facsimile: +81 596 24 8124

Test site	Width x Depth x Height (m)	Size of reference ground plane (m) / horizontal conducting plane	Other rooms	Maximum measurement distance
No.1 semi-anechoic chamber	19.2 x 11.2 x 7.7	7.0 x 6.0	No.1 Power source room	10 m
No.2 semi-anechoic chamber	7.5 x 5.8 x 5.2	4.0 x 4.0	-	3 m
No.3 semi-anechoic chamber	12.0 x 8.5 x 5.9	6.8 x 5.75	No.3 Preparation room	3 m
No.3 shielded room	4.0 x 6.0 x 2.7	N/A	-	-
No.4 semi-anechoic chamber	12.0 x 8.5 x 5.9	6.8 x 5.75	No.4 Preparation room	3 m
No.4 shielded room	4.0 x 6.0 x 2.7	N/A	-	-
No.5 semi-anechoic chamber	6.0 x 6.0 x 3.9	6.0 x 6.0	-	-
No.5 measurement room	6.4 x 6.4 x 3.0	6.4 x 6.4	-	-
No.6 shielded room	4.0 x 4.5 x 2.7	4.0 x 4.5	-	-
No.6 measurement room	4.75 x 5.4 x 3.0	4.75 x 4.15	-	-
No.7 shielded room	4.7 x 7.5 x 2.7	4.7 x 7.5	-	-
No.8 measurement room	3.1 x 5.0 x 2.7	3.1 x 5.0	-	-
No.9 measurement room	8.8 x 4.6 x 2.8	2.4 x 2.4	-	-
No.11 measurement room	6.2 x 4.7 x 3.0	4.8 x 4.6	-	-

\* Size of vertical conducting plane (for Conducted Emission test) : 2.0 x 2.0 m for No.1, No.2, No.3, and No.4 semi-anechoic chambers and No.3 and No.4 shielded rooms.

### 3.6 Test data, Test instruments, and Test set up

Refer to APPENDIX.

## **SECTION 4: Operation of EUT during testing**

### **4.1 Operating mode(s)**

The mode is used :

Test mode	Remarks
1) Normal Operating mode (120.3 kHz / 5 W)	Mode 1
2) Normal Operating mode (127.5 kHz / 10 W)	Mode 2
3) Normal Operating mode (127.0 kHz / 5 W)	Mode 3
4) Normal Operating mode (127.627 kHz / 10 W)	Mode 4
5) Normal Operating mode (127.756 kHz / 10 W)	Mode 5
6) Normal Operating mode (128.016 kHz / 10 W)	Mode 6
7) Normal Operating mode (128.549 kHz / 10 W)	Mode 7
8) Normal Operating mode (127.373 kHz / 10 W)	Mode 8
9) Normal Operating mode (127.248 kHz / 10 W)	Mode 9
10) Normal Operating mode (126.999 kHz / 10 W)	Mode 10
11) Normal Operating mode (126.515 kHz / 10 W)	Mode 11

### **4.2 Configuration and peripherals**

[Mode 1 to 3]

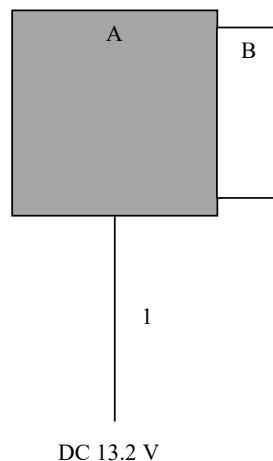

\* Cabling and setup(s) were taken into consideration and test data was taken under worse case conditions.

#### **Description of EUT and Support equipment**

No.	Item	Model number	Serial number	Manufacturer	Remarks
A	Wireless Charger	AT2001	1.5S-001	Panasonic Corporation	EUT
B	Test Jig	PAS-JS100	101	Panasonic Corporation	-

\*A and B communicates and charges via air interface.

#### **List of cables used**

No.	Name	Length (m)	Shield		Remark
			Cable	Connector	
1	Power Cable	2.3	Unshielded	Unshielded	-

**UL Japan, Inc.**

**Ise EMC Lab.**

4383-326 Asama-cho, Ise-shi, Mie-ken 516-0021 JAPAN

Telephone : +81 596 24 8999

Facsimile : +81 596 24 8124

[Mode 4 to 11]

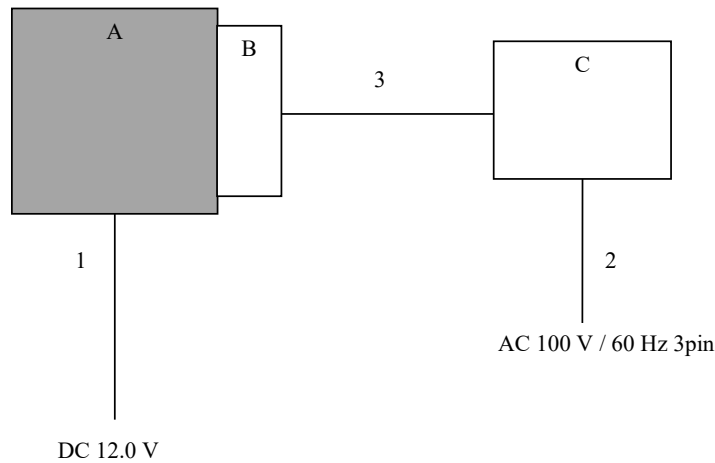

\* Cabling and setup(s) were taken into consideration and test data was taken under worse case conditions.

**Description of EUT and Support equipment**

No.	Item	Model number	Serial number	Manufacturer	Remarks
A	Wireless Charger	AT2001	1.5S-001	Panasonic Corporation	EUT
B	Communication probe	-	-	nok9	-
C	Desk top PC	LP/MP/FOD	200134-1807	nok9	-

\*A and B communicates and charges via air interface.

**List of cables used**

No.	Name	Length (m)	Shield		Remark
			Cable	Connector	
1	Power Cable	2.3	Unshielded	Unshielded	-
2	Power Cable	1.5	Unshielded	Unshielded	-
3	Communication cable	0.6	Shielded	Shielded	-

**UL Japan, Inc.**

**Ise EMC Lab.**

4383-326 Asama-cho, Ise-shi, Mie-ken 516-0021 JAPAN

Telephone : +81 596 24 8999

Facsimile : +81 596 24 8124

## **SECTION 5: Radiated Emission**

### **5.1 Operating environment**

Test place : No.1 semi anechoic chamber  
Temperature : See data  
Humidity : See data

### **5.2 Test configuration**

EUT was placed on a urethane platform of nominal size, 0.5 m by 1.0 m, raised 1.0 m above the conducting ground plane. The EUT was set on the center of the table top.  
Test was made with the antenna positioned in 0 deg., 45 deg., 90 deg., 135deg., and 180 deg..  
The measurement antenna was varied in height above the conducting ground plane to obtain the maximum signal strength. Photographs of the set up are shown in Appendix 3.  
\*Refer to Figure 1 about Direction of the Loop Antenna.

### **5.3 Test conditions**

Frequency range : 9 kHz - 30 MHz (Loop antenna)  
30 MHz - 200 MHz (Biconical antenna)  
200 MHz - 400 MHz (Logperiodic antenna)  
Test distance : 3 m / 10 m  
EUT position : Table top  
EUT operation mode : See Clause 4.1

### **5.4 Test procedure**

#### **Below 30 MHz**

The height of antenna was fixed in 2 m.  
EUT was rotated a full revolution in order to obtain the maximum value of the electric field intensity.  
The measurements were performed in 0 deg., 45 deg., 90 deg., 135deg., and 180 deg. with the Test Receiver.  
The test was made with the detector (RBW) in the following table.  
The electric field intensity at a distance of 300 m was calculated from the measurement results at distances of 3 m and 10 m.

#### **Above 30 MHz**

Maximum electric field intensity was confirmed with the measurements at distances of 3 m and 10 m.  
The electric field intensity at a distance of 300 m was calculated from the measurement results at distances of 3 m and 10 m.  
The radiated emission measurements were made with the following detector function of the test receiver.  
The test was made with the detector (RBW) in the following table.

Frequency	9 kHz - 150 kHz	150 kHz - 30 MHz	30 MHz - 400 MHz
Instrument used	Test Receiver		
IF Bandwidth	AV: 200 Hz	AV: 9 kHz	AV: 120 kHz

The measurement result was calculated by the following formula:

[Frequency at which the signal was confirmed at both 10m and 3m]

Result = Reading + ANT Factor + Cable loss + Atten loss + Extrapolation Factor - AMP gain

Extrapolation Factor = decade \* Log (Test distance (3m) / Separate distance (300m))

decade = (10m reading - 3m reading) / (log 3m - log 10m)

\*Refer to Part 18 Section 305 Notes 2 and KDB 629601.

[Other Frequency]

Result = Reading + ANT Factor + Cable loss + Atten loss + Extrapolation Factor - AMP gain

Extrapolation Factor = 20 \* Log (Test distance (3m) / Separate distance (300m))

<Test Setup>

Below 1 GHz

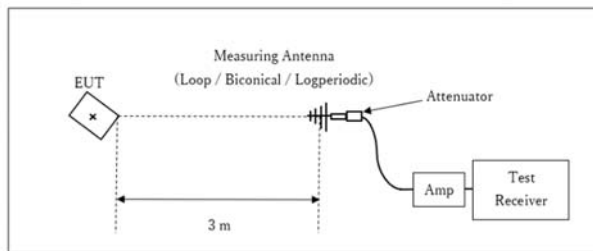

Test Distance: 3 m

- The carrier level and noise levels were confirmed at each position of X, Y and Z axes of EUT to see the position of maximum noise, and the test was made at the position that has the maximum noise.

## 5.5 Test result

Summary of the test results: Pass

Date: March 31, 2020  
April 13 and 16, 2020  
April 24 and 25, 2020  
May 2, 2020

Test engineer: Hiroyuki Furutaka  
Masaya Minami  
Tomohisa Nakagawa  
Ken Fujita

**UL Japan, Inc.**

**Ise EMC Lab.**

4383-326 Asama-cho, Ise-shi, Mie-ken 516-0021 JAPAN

Telephone : +81 596 24 8999

Facsimile : +81 596 24 8124

Figure 1: Direction of the Loop Antenna

*Side View (Vertical)*

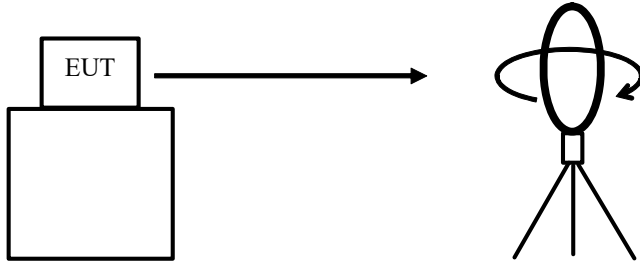

.....  
*Top View (Horizontal)*

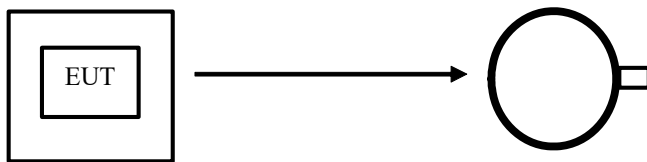

Antenna was not rotated.

.....

*Top View (Vertical)*

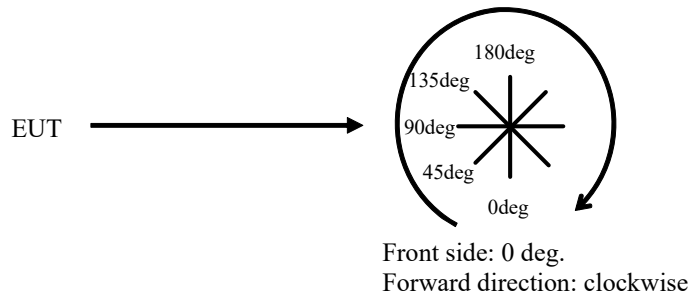

**APPENDIX 1: Test data**

**Radiated Emission**  
**(Below 30 MHz)**

Report No. 13226969H  
Test place Ise EMC Lab.  
Semi Anechoic Chamber No.1  
Date March 31, 2020  
Temperature / Humidity 24 deg. C / 34 % RH  
Engineer Hiroyuki Furutaka  
Mode Mode 1

FREQ [MHz]	Reading (3m) [dBμV]	Reading (10m) [dBμV]	ANT Factor [dB/m]	Atten + Cable loss [dB]	AMP Gain [dB]	Extrapolation Factor [dB]	Result (300 m) [dBμV/m]	Limit (300 m) [dBμV/m]	Margin [dB]	Antenna [deg]
0.1203	65.6	37.1	19.9	6.0	32.1	-109.0	-49.6	23.5	73.1	0
0.1203	64.5	36.8	19.9	6.0	32.1	-106.0	-47.6	23.5	71.1	45
0.1203	62.9	36.5	19.9	6.0	32.1	-101.0	-44.2	23.5	67.7	90
0.1203	63.5	37.0	19.9	6.0	32.1	-101.4	-44.0	23.5	67.5	135
0.1203	65.5	37.0	19.9	6.0	32.1	-109.0	-49.7	23.5	73.2	180
0.1203	64.3	36.8	19.9	6.0	32.1	-105.2	-47.0	23.5	70.5	Horizontal
0.2406	31.6	NS	19.9	6.0	32.1	-40.0	-14.5	23.5	38.0	0
0.3609	46.8	NS	19.9	6.1	32.1	-40.0	0.6	23.5	22.9	0
0.4812	27.3	NS	19.8	6.1	32.1	-40.0	-18.9	25.5	44.4	0
0.6015	38.1	NS	19.8	6.1	32.0	-40.0	-8.1	23.5	31.6	0
0.7218	26.0	NS	19.8	6.1	32.0	-40.0	-20.1	23.5	43.6	0
0.8421	32.5	NS	19.8	6.2	32.0	-40.0	-13.6	23.5	37.1	0
1.0827	29.0	NS	19.8	6.2	32.0	-40.0	-17.1	23.5	40.6	0

NS : No-Signal  
Except for the above table : adequate margin data below the limits.

**Radiated emission**  
**(Below 30 MHz)**

Report No. 13226969H  
Test place Ise EMC Lab.  
Semi Anechoic Chamber No.1  
Date March 31, 2020  
Temperature / Humidity 24 deg. C / 34 % RH  
Engineer Hiroyuki Furutaka  
Mode Mode 2

FREQ [MHz]	Reading (3m) [dBμV]	Reading (10m) [dBμV]	ANT Factor [dB/m]	Atten + Cable loss [dB]	AMP Gain [dB]	Extrapolation Factor [dB]	Result (300 m) [dBμV/m]	Limit (300 m) [dBμV/m]	Margin [dB]	Antenna [deg]
0.1275	75.5	42.5	19.9	6.0	32.1	-126.2	-56.9	23.5	80.4	0
0.1275	74.8	42.5	19.9	6.0	32.1	-123.5	-54.9	23.5	78.4	45
0.1275	73.8	42.4	19.9	6.0	32.1	-120.1	-52.5	23.5	76.0	90
0.1275	74.1	42.5	19.9	6.0	32.1	-120.9	-52.9	23.5	76.4	135
0.1275	75.4	42.4	19.9	6.0	32.1	-126.2	-57.0	23.5	80.5	180
0.1275	56.4	41.3	19.9	6.0	32.1	-57.8	-7.5	23.5	31.0	Horizontal
0.2550	34.5	NS	19.9	6.0	32.1	-40.0	-11.7	23.5	35.2	0
0.3825	53.7	NS	19.8	6.1	32.1	-40.0	7.5	23.5	16.0	0
0.5100	29.7	NS	19.8	6.1	32.1	-40.0	-16.5	25.5	42.0	0
0.6375	44.6	NS	19.8	6.1	32.0	-40.0	-1.5	23.5	25.0	0
0.7649	26.4	NS	19.8	6.1	32.0	-40.0	-19.7	23.5	43.2	0
0.8924	37.6	NS	19.8	6.2	32.0	-40.0	-8.5	23.5	32.0	0
1.1474	30.9	NS	19.8	6.2	32.0	-40.0	-15.2	23.5	38.7	0

NS : No-Signal

Except for the above table : adequate margin data below the limits.

**Radiated Emission**  
**(Below 30 MHz)**

Report No. 13226969H  
Test place Ise EMC Lab.  
Semi Anechoic Chamber No.1  
Date April 16, 2020  
Temperature / Humidity 23 deg. C / 43 % RH  
Engineer Masaya Minami  
Mode Mode 3

FREQ [MHz]	Reading (3m) [dBμV]	Reading (10m) [dBμV]	ANT Factor [dB/m]	Atten + Cable loss [dB]	AMP Gain [dB]	Extrapolation Factor [dB]	Result (300 m) [dBμV/m]	Limit (300 m) [dBμV/m]	Margin [dB]	Antenna [deg]
0.1270	77.5	35.0	19.9	6.0	32.1	-162.6	-91.2	23.5	114.7	0
0.1270	74.3	34.4	19.9	6.0	32.1	-152.6	-84.5	23.5	108.0	45
0.1270	73.1	34.4	19.9	6.0	32.1	-148.0	-81.1	23.5	104.6	90
0.1270	72.4	34.2	19.9	6.0	32.1	-146.1	-79.9	23.5	103.4	135
0.1270	76.9	34.3	19.9	6.0	32.1	-162.9	-92.2	23.5	115.7	180
0.1270	66.3	30.6	19.9	6.0	32.1	-136.6	-76.4	23.5	99.9	Horizontal
0.2540	36.4	NS	19.9	6.0	32.1	-40.0	-9.8	23.5	33.3	0
0.3810	56.6	NS	19.8	6.1	32.1	-40.0	10.4	23.5	13.1	0
0.5080	29.8	NS	19.8	6.1	32.1	-40.0	-16.4	25.5	41.9	0
0.6350	46.9	NS	19.8	6.1	32.0	-40.0	0.8	23.5	22.7	0
0.7620	27.3	NS	19.8	6.1	32.0	-40.0	-18.8	23.5	42.3	0
0.8890	39.9	NS	19.8	6.2	32.0	-40.0	-6.2	23.5	29.7	0
1.0160	26.6	NS	19.8	6.2	32.0	-40.0	-19.5	23.5	43.0	0

NS : No-Signal

Except for the above table : adequate margin data below the limits.

**Radiated Emission**  
**(Below 30 MHz)**

Report No. 13226969H  
Test place Ise EMC Lab.  
Semi Anechoic Chamber No.1  
Date April 24, 2020  
Temperature / Humidity 24 deg. C / 40 % RH  
Engineer Tomohisa Nakagawa  
Mode Mode 4

FREQ [MHz]	Reading (3m) [dBμV]	Reading (10m) [dBμV]	ANT Factor [dB/m]	Atten + Cable loss [dB]	AMP Gain [dB]	Extrapolation Factor [dB]	Result (300 m) [dBμV/m]	Limit (300 m) [dBμV/m]	Margin [dB]	Antenna [deg]
0.1276	75.6	46.8	19.9	6.0	32.1	-110.2	-40.7	23.5	64.2	0
0.1276	73.7	45.7	19.9	6.0	32.1	-107.1	-39.5	23.5	63.0	45
0.1276	70.0	43.6	19.9	6.0	32.1	-101.0	-37.1	23.5	60.6	90
0.1276	73.6	45.7	19.9	6.0	32.1	-106.7	-39.3	23.5	62.8	135
0.1276	75.6	46.6	19.9	6.0	32.1	-110.9	-41.5	23.5	65.0	180
0.1276	81.7	41.2	19.9	6.0	32.1	-154.9	-79.4	23.5	102.9	Horizontal
0.2553	49.1	NS	19.9	6.0	32.1	-40.0	3.0	23.5	20.6	Horizontal
0.3829	58.9	NS	19.9	6.0	32.1	-40.0	12.8	23.5	10.8	Horizontal
0.5105	39.0	NS	19.9	6.0	32.1	-40.0	-7.2	23.5	30.7	Horizontal
0.6382	49.0	NS	19.9	6.0	32.1	-40.0	2.9	23.5	20.7	Horizontal
0.7658	33.0	NS	19.9	6.0	32.1	-40.0	-13.2	23.5	36.7	Horizontal
0.8934	42.5	NS	19.9	6.0	32.1	-40.0	-3.7	23.5	27.2	Horizontal
1.0210	29.4	NS	19.8	6.1	32.1	-40.0	-16.8	23.5	40.3	Horizontal
1.1487	38.1	NS	19.8	6.1	32.1	-40.0	-8.1	25.5	33.6	Horizontal
1.2763	27.7	NS	19.8	6.1	32.1	-40.0	-18.5	23.5	42.0	Horizontal

NS : No-Signal  
Except for the above table : adequate margin data below the limits.

**Radiated Emission**  
**(Below 30 MHz)**

Report No. 13226969H  
Test place Ise EMC Lab.  
Semi Anechoic Chamber No.1  
Date April 24, 2020  
Temperature / Humidity 24 deg. C / 40 % RH  
Engineer Tomohisa Nakagawa  
Mode Mode 5

FREQ [MHz]	Reading (3m) [dBμV]	Reading (10m) [dBμV]	ANT Factor [dB/m]	Atten + Cable loss [dB]	AMP Gain [dB]	Extrapolation Factor [dB]	Result (300 m) [dBμV/m]	Limit (300 m) [dBμV/m]	Margin [dB]	Antenna [deg]
0.1278	75.5	46.0	19.9	6.0	32.1	-112.8	-43.5	23.5	67.0	0
0.1278	73.0	45.1	19.9	6.0	32.1	-106.7	-39.9	23.5	63.4	45
0.1278	69.8	43.4	19.9	6.0	32.1	-101.0	-37.3	23.5	60.8	90
0.1278	73.9	45.2	19.9	6.0	32.1	-109.8	-42.0	23.5	65.5	135
0.1278	75.2	46.0	19.9	6.0	32.1	-111.7	-42.6	23.5	66.1	180
0.1278	83.4	41.1	19.9	6.0	32.1	-161.8	-84.5	23.5	108.0	Horizontal
0.2555	49.2	NS	19.9	6.0	32.1	-40.0	3.1	23.5	20.5	Horizontal
0.3833	60.1	NS	19.8	6.1	32.1	-40.0	13.9	23.5	9.6	Horizontal
0.5110	40.6	NS	19.8	6.1	32.1	-40.0	-5.6	23.5	29.1	Horizontal
0.6388	49.6	NS	19.8	6.1	32.0	-40.0	3.5	23.5	20.0	Horizontal
0.7666	34.5	NS	19.8	6.1	32.0	-40.0	-11.6	23.5	35.1	Horizontal
0.8943	42.5	NS	19.8	6.2	32.0	-40.0	-3.6	23.5	27.1	Horizontal
1.0221	36.7	NS	19.8	6.2	32.0	-40.0	-9.4	23.5	32.9	Horizontal
1.1498	38.2	NS	19.8	6.2	32.0	-40.0	-7.9	25.5	33.4	Horizontal
1.2776	28.4	NS	19.8	6.2	32.0	-40.0	-17.6	23.5	41.1	Horizontal

NS : No-Signal  
Except for the above table : adequate margin data below the limits.

**Radiated Emission**  
**(Below 30 MHz)**

Report No. 13226969H  
Test place Ise EMC Lab.  
Semi Anechoic Chamber No.1  
Date April 24, 2020  
Temperature / Humidity 24 deg. C / 40 % RH  
Engineer Tomohisa Nakagawa  
Mode Mode 6

FREQ [MHz]	Reading (3m) [dBμV]	Reading (10m) [dBμV]	ANT Factor [dB/m]	Atten + Cable loss [dB]	AMP Gain [dB]	Extrapolation Factor [dB]	Result (300 m) [dBμV/m]	Limit (300 m) [dBμV/m]	Margin [dB]	Antenna [deg]
0.1280	76.7	46.7	19.9	6.0	32.1	-114.7	-44.2	23.5	67.7	0
0.1280	74.6	45.2	19.9	6.0	32.1	-112.5	-44.0	23.5	67.5	45
0.1280	70.8	43.6	19.9	6.0	32.1	-104.0	-39.4	23.5	62.9	90
0.1280	74.9	45.5	19.9	6.0	32.1	-112.5	-43.7	23.5	67.2	135
0.1280	76.6	46.5	19.9	6.0	32.1	-115.1	-44.7	23.5	68.2	180
0.1280	83.2	41.2	19.9	6.0	32.1	-160.6	-83.6	23.5	107.1	Horizontal
0.2560	49.8	NS	19.9	6.0	32.1	-40.0	3.7	23.5	19.9	Horizontal
0.3841	60.7	NS	19.8	6.1	32.1	-40.0	14.5	23.5	9.0	Horizontal
0.5121	41.0	NS	19.8	6.1	32.1	-40.0	-5.2	23.5	28.7	Horizontal
0.6401	51.2	NS	19.8	6.1	32.0	-40.0	5.1	23.5	18.4	Horizontal
0.7681	34.8	NS	19.8	6.1	32.0	-40.0	-11.3	23.5	34.8	Horizontal
0.8961	44.6	NS	19.8	6.2	32.0	-40.0	-1.5	23.5	25.0	Horizontal
1.0241	31.3	NS	19.8	6.2	32.0	-40.0	-14.8	23.5	38.3	Horizontal
1.1521	39.9	NS	19.8	6.2	32.0	-40.0	-6.2	25.5	31.7	Horizontal
1.2802	29.2	NS	19.8	6.2	32.0	-40.0	-16.8	23.5	40.3	Horizontal

NS : No-Signal  
Except for the above table : adequate margin data below the limits.

**Radiated Emission**  
**(Below 30 MHz)**

Report No. 13226969H  
Test place Ise EMC Lab.  
Semi Anechoic Chamber No.1  
Date April 24, 2020  
Temperature / Humidity 24 deg. C / 40 % RH  
Engineer Tomohisa Nakagawa  
Mode Mode 7

FREQ [MHz]	Reading (3m) [dBμV]	Reading (10m) [dBμV]	ANT Factor [dB/m]	Atten + Cable loss [dB]	AMP Gain [dB]	Extrapolation Factor [dB]	Result (300 m) [dBμV/m]	Limit (300 m) [dBμV/m]	Margin [dB]	Antenna [deg]
0.1286	77.0	46.3	19.9	6.0	32.1	-117.4	-46.6	23.5	70.1	0
0.1286	74.8	45.3	19.9	6.0	32.1	-112.8	-44.2	23.5	67.7	45
0.1286	70.9	43.8	19.9	6.0	32.1	-103.7	-38.9	23.5	62.4	90
0.1286	75.2	45.5	19.9	6.0	32.1	-113.6	-44.6	23.5	68.1	135
0.1286	77.0	46.3	19.9	6.0	32.1	-117.4	-46.6	23.5	70.1	180
0.1286	83.1	41.3	19.9	6.0	32.1	-159.9	-82.9	23.5	106.4	Horizontal
0.2571	49.5	NS	19.9	6.0	32.1	-40.0	3.4	23.5	20.2	Horizontal
0.3857	60.3	NS	19.8	6.1	32.1	-40.0	14.1	23.5	9.4	Horizontal
0.5142	40.6	NS	19.8	6.1	32.1	-40.0	-5.6	23.5	29.1	Horizontal
0.6428	51.0	NS	19.8	6.1	32.0	-40.0	4.9	23.5	18.6	Horizontal
0.7713	34.0	NS	19.8	6.1	32.0	-40.0	-12.1	23.5	35.6	Horizontal
0.8998	44.3	NS	19.8	6.2	32.0	-40.0	-1.8	23.5	25.3	Horizontal
1.0284	30.6	NS	19.8	6.2	32.0	-40.0	-15.5	23.5	39.0	Horizontal
1.1569	39.9	NS	19.8	6.2	32.0	-40.0	-6.2	25.5	31.7	Horizontal
1.2855	28.7	NS	19.8	6.2	32.0	-40.0	-17.3	23.5	40.8	Horizontal

NS : No-Signal  
Except for the above table : adequate margin data below the limits.

**Radiated Emission**  
**(Below 30 MHz)**

Report No. 13226969H  
Test place Ise EMC Lab.  
Semi Anechoic Chamber No.1  
Date April 25, 2020  
Temperature / Humidity 24 deg. C / 39 % RH  
Engineer Tomohisa Nakagawa  
Mode Mode 8

FREQ [MHz]	Reading (3m) [dBμV]	Reading (10m) [dBμV]	ANT Factor [dB/m]	Atten + Cable loss [dB]	AMP Gain [dB]	Extrapolation Factor [dB]	Result (300 m) [dBμV/m]	Limit (300 m) [dBμV/m]	Margin [dB]	Antenna [deg]
0.1274	76.0	46.3	19.9	6.0	32.1	-113.6	-43.8	23.5	67.3	0
0.1274	73.7	45.1	19.9	6.0	32.1	-109.4	-41.8	23.5	65.3	45
0.1274	68.8	43.4	19.9	6.0	32.1	-97.2	-34.5	23.5	58.0	90
0.1274	74.1	45.4	19.9	6.0	32.1	-109.8	-41.8	23.5	65.3	135
0.1274	75.9	46.3	19.9	6.0	32.1	-113.2	-43.5	23.5	67.0	180
0.1274	83.5	41.3	19.9	6.0	32.1	-161.4	-84.1	23.5	107.6	Horizontal
0.2547	48.4	NS	19.9	6.0	32.1	-40.0	2.2	23.5	21.3	Horizontal
0.3821	59.8	NS	19.8	6.1	32.1	-40.0	13.6	23.5	9.9	Horizontal
0.5095	39.9	NS	19.8	6.1	32.1	-40.0	-6.3	23.5	29.8	Horizontal
0.6369	49.1	NS	19.8	6.1	32.0	-40.0	3.0	23.5	20.5	Horizontal
0.7642	34.3	NS	19.8	6.1	32.0	-40.0	-11.8	23.5	35.3	Horizontal
0.8916	41.5	NS	19.8	6.2	32.0	-40.0	-4.6	23.5	28.1	Horizontal
1.0190	31.4	NS	19.8	6.2	32.0	-40.0	-14.7	23.5	38.2	Horizontal
1.1463	37.6	NS	19.8	6.2	32.0	-40.0	-8.5	25.5	34.0	Horizontal
1.2737	29.0	NS	19.8	6.2	32.0	-40.0	-17.0	23.5	40.5	Horizontal

NS : No-Signal

Except for the above table : adequate margin data below the limits.

**Radiated Emission**  
**(Below 30 MHz)**

Report No. 13226969H  
Test place Ise EMC Lab.  
Semi Anechoic Chamber No.1  
Date April 25, 2020  
Temperature / Humidity 24 deg. C / 39 % RH  
Engineer Tomohisa Nakagawa  
Mode Mode 9

FREQ [MHz]	Reading (3m) [dBμV]	Reading (10m) [dBμV]	ANT Factor [dB/m]	Atten + Cable loss [dB]	AMP Gain [dB]	Extrapolation Factor [dB]	Result (300 m) [dBμV/m]	Limit (300 m) [dBμV/m]	Margin [dB]	Antenna [deg]
0.1273	76.4	46.5	19.9	6.0	32.1	-114.4	-44.1	23.5	67.6	0
0.1273	74.0	45.6	19.9	6.0	32.1	-108.6	-40.8	23.5	64.3	45
0.1273	68.6	43.8	19.9	6.0	32.1	-94.9	-32.4	23.5	55.9	90
0.1273	74.2	45.7	19.9	6.0	32.1	-109.0	-41.0	23.5	64.5	135
0.1273	76.0	46.5	19.9	6.0	32.1	-112.8	-43.0	23.5	66.5	180
0.1273	83.7	41.0	19.9	6.0	32.1	-163.3	-85.8	23.5	109.3	Horizontal
0.2545	47.9	NS	19.9	6.0	32.1	-40.0	1.7	23.5	21.8	Horizontal
0.3817	59.7	NS	19.8	6.1	32.1	-40.0	13.5	23.5	10.0	Horizontal
0.5090	39.8	NS	19.8	6.1	32.1	-40.0	-6.4	23.5	29.9	Horizontal
0.6362	48.8	NS	19.8	6.1	32.0	-40.0	2.7	23.5	20.8	Horizontal
0.7635	34.5	NS	19.8	6.1	32.0	-40.0	-11.6	23.5	35.1	Horizontal
0.8907	41.4	NS	19.8	6.2	32.0	-40.0	-4.7	23.5	28.2	Horizontal
1.0180	31.5	NS	19.8	6.2	32.0	-40.0	-14.6	23.5	38.1	Horizontal
1.1452	37.4	NS	19.8	6.2	32.0	-40.0	-8.7	25.5	34.2	Horizontal
1.2725	28.5	NS	19.8	6.2	32.0	-40.0	-17.5	23.5	41.0	Horizontal

NS : No-Signal

Except for the above table : adequate margin data below the limits.

**UL Japan, Inc.**

**Ise EMC Lab.**

4383-326 Asama-cho, Ise-shi, Mie-ken 516-0021 JAPAN

Telephone : +81 596 24 8999

Facsimile : +81 596 24 8124

**Radiated Emission**  
**(Below 30 MHz)**

Report No. 13226969H  
Test place Ise EMC Lab.  
Semi Anechoic Chamber No.1  
Date April 25, 2020  
Temperature / Humidity 24 deg. C / 39 % RH  
Engineer Tomohisa Nakagawa  
Mode Mode 10

FREQ [MHz]	Reading (3m) [dBμV]	Reading (10m) [dBμV]	ANT Factor [dB/m]	Atten + Cable loss [dB]	AMP Gain [dB]	Extrapolation Factor [dB]	Result (300 m) [dBμV/m]	Limit (300 m) [dBμV/m]	Margin [dB]	Antenna [deg]
0.1270	75.8	46.7	19.9	6.0	32.1	-111.3	-41.7	23.5	65.2	0
0.1270	73.2	45.7	19.9	6.0	32.1	-105.2	-38.1	23.5	61.6	45
0.1270	68.4	43.3	19.9	6.0	32.1	-96.0	-33.8	23.5	57.3	90
0.1270	74.4	45.7	19.9	6.0	32.1	-109.8	-41.5	23.5	65.0	135
0.1270	76.2	46.7	19.9	6.0	32.1	-112.8	-42.8	23.5	66.3	180
0.1270	83.1	41.0	19.9	6.0	32.1	-161.0	-84.1	23.5	107.6	Horizontal
0.2540	48.2	NS	19.9	6.0	32.1	-40.0	2.1	23.5	21.5	Horizontal
0.3810	59.5	NS	19.8	6.1	32.1	-40.0	13.3	23.5	10.2	Horizontal
0.5080	40.3	NS	19.8	6.1	32.1	-40.0	-5.9	23.5	29.4	Horizontal
0.6350	48.8	NS	19.8	6.1	32.0	-40.0	2.7	23.5	20.8	Horizontal
0.7620	34.1	NS	19.8	6.1	32.0	-40.0	-12.0	23.5	35.5	Horizontal
0.8890	41.1	NS	19.8	6.2	32.0	-40.0	-5.0	23.5	28.5	Horizontal
1.0160	30.9	NS	19.8	6.2	32.0	-40.0	-15.2	23.5	38.7	Horizontal
1.1430	38.1	NS	19.8	6.2	32.0	-40.0	-8.0	25.5	33.5	Horizontal
1.2700	29.3	NS	19.8	6.2	32.0	-40.0	-16.7	23.5	40.2	Horizontal

NS : No-Signal

Except for the above table : adequate margin data below the limits.

**Radiated Emission**  
**(Below 30 MHz)**

Report No. 13226969H  
Test place Ise EMC Lab.  
Semi Anechoic Chamber No.1  
Date April 25, 2020  
Temperature / Humidity 24 deg. C / 39 % RH  
Engineer Tomohisa Nakagawa  
Mode Mode 11

FREQ [MHz]	Reading (3m) [dBμV]	Reading (10m) [dBμV]	ANT Factor [dB/m]	Atten + Cable loss [dB]	AMP Gain [dB]	Extrapolation Factor [dB]	Result (300 m) [dBμV/m]	Limit (300 m) [dBμV/m]	Margin [dB]	Antenna [deg]
0.1265	76.1	46.6	19.9	6.0	32.1	-112.8	-42.9	23.5	66.4	0
0.1265	73.6	45.6	19.9	6.0	32.1	-107.1	-39.6	23.5	63.1	45
0.1265	68.3	43.3	19.9	6.0	32.1	-95.6	-33.5	23.5	57.0	90
0.1265	73.6	45.6	19.9	6.0	32.1	-107.1	-39.6	23.5	63.1	135
0.1265	75.4	46.5	19.9	6.0	32.1	-110.5	-41.3	23.5	64.8	180
0.1265	83.9	41.4	19.9	6.0	32.1	-162.6	-84.8	23.5	108.3	Horizontal
0.2530	48.2	NS	19.9	6.0	32.1	-40.0	2.1	23.5	21.5	Horizontal
0.3796	59.6	NS	19.9	6.1	32.1	-40.0	13.5	23.5	10.1	Horizontal
0.5061	40.1	NS	19.8	6.1	32.1	-40.0	-6.1	23.5	29.6	Horizontal
0.6326	48.8	NS	19.8	6.1	32.0	-40.0	2.7	23.5	20.9	Horizontal
0.7591	34.6	NS	19.8	6.1	32.0	-40.0	-11.5	23.5	35.0	Horizontal
0.8856	41.4	NS	19.8	6.2	32.0	-40.0	-4.7	23.5	28.2	Horizontal
1.0121	30.9	NS	19.8	6.2	32.0	-40.0	-15.2	23.5	38.7	Horizontal
1.1386	38.1	NS	19.8	6.2	32.0	-40.0	-8.0	25.5	33.5	Horizontal
1.2652	29.3	NS	19.8	6.2	32.0	-40.0	-16.7	23.5	40.2	Horizontal

NS : No-Signal

Except for the above table : adequate margin data below the limits.

**UL Japan, Inc.**

**Ise EMC Lab.**

4383-326 Asama-cho, Ise-shi, Mie-ken 516-0021 JAPAN

Telephone : +81 596 24 8999

Facsimile : +81 596 24 8124

**Radiated Emission**  
**(Above 30 MHz)**

UL Japan, Inc.  
Ise EMC Lab.  
No.1 Semi Anechoic Chamber

Test Distance : 3m  
Data : 04/13/2020  
Temperature : 21 deg.C.  
Humidity : 43 % RH  
Engineer : Masaya Minami

Remark : Mode 1  
Detector : Average

FREQ [MHz]	Reading (3m) [dBμV]	ANT Factor [dB/m]	AMP gain [dB]	Atten + Cable loss [dB]	Extrapolation Factor [dB]	Result (300 m) [dBμV/m]	Limit (300 m) [dBμV/m]	Margin [dB]	Antenna Polarization	Remarks
43.416	21.7	13.4	38.8	7.7	-40.0	-36.0	23.5	59.5	Horizontal	NS
64.109	25.2	6.9	38.8	8.0	-40.0	-38.7	23.5	62.2	Horizontal	
98.383	28.2	9.8	38.9	8.6	-40.0	-32.4	23.5	55.9	Horizontal	
134.321	21.9	14.0	38.9	9.0	-40.0	-34.0	23.5	57.5	Horizontal	NS
178.020	21.5	16.0	38.9	9.5	-40.0	-31.9	23.5	55.4	Horizontal	NS
386.530	20.2	15.3	38.5	11.4	-40.0	-31.6	23.5	55.1	Horizontal	NS
43.416	36.0	13.4	38.8	7.7	-40.0	-21.7	23.5	45.2	Vertical	
64.109	29.1	6.9	38.8	8.0	-40.0	-34.8	23.5	58.3	Vertical	
98.383	30.9	9.8	38.9	8.6	-40.0	-29.7	23.5	53.2	Vertical	
134.333	27.1	14.0	38.9	9.0	-40.0	-28.8	23.5	52.3	Vertical	
178.020	22.5	16.0	38.9	9.5	-40.0	-30.9	23.5	54.4	Vertical	NS
386.411	21.2	15.3	38.5	11.4	-40.0	-30.6	23.5	54.1	Vertical	NS

CALCULATION(Result) : Reading + ANT Factor + Cable loss + Atten loss + Extrapolation Factor - AMP gain  
Extrapolation Factor = 20\*Log (Test distance(3m) / Separate distance(300m))

NS : No-Signal  
Except for the above table : adequate margin data below the limits.

**Radiated Emission**  
**(Above 30 MHz)**

UL Japan, Inc.  
Ise EMC Lab.  
No.1 Semi Anechoic Chamber

Test Distance : 3m  
Data : 04/13/2020  
Temperature : 21 deg.C.  
Humidity : 43 % RH  
Engineer : Masaya Minami

Remark : Mode 2  
Detector : Average

FREQ [MHz]	Reading (3m) [dBμV]	ANT Factor [dB/m]	AMP gain [dB]	Atten + Cable loss [dB]	Extrapolation Factor [dB]	Result (300 m) [dBμV/m]	Limit (300 m) [dBμV/m]	Margin [dB]	Antenna Polarization	Remarks
43.543	21.8	13.4	38.8	7.7	-40.0	-36.0	23.5	59.5	Horizontal	NS
68.570	27.7	6.5	38.9	8.1	-40.0	-36.6	23.5	60.1	Horizontal	NS
127.366	21.4	13.4	38.9	8.9	-40.0	-35.2	23.5	58.7	Horizontal	NS
163.751	21.3	15.4	38.9	9.4	-40.0	-32.8	23.5	56.3	Horizontal	NS
177.894	22.4	16.0	38.9	9.5	-40.0	-31.0	23.5	54.5	Horizontal	NS
386.420	20.2	15.3	38.5	11.4	-40.0	-31.6	23.5	55.1	Horizontal	NS
43.608	35.3	13.4	38.8	7.7	-40.0	-22.5	23.5	46.0	Vertical	
70.125	41.6	6.4	38.9	8.1	-40.0	-22.7	23.5	46.2	Vertical	
127.990	30.0	13.6	38.9	9.0	-40.0	-26.4	23.5	49.9	Vertical	
159.992	24.9	15.3	38.9	9.4	-40.0	-29.4	23.5	52.9	Vertical	
177.894	22.3	16.0	38.9	9.5	-40.0	-31.1	23.5	54.6	Vertical	NS
386.420	21.3	15.3	38.5	11.4	-40.0	-30.5	23.5	54.0	Vertical	NS

CALCULATION(Result) : Reading + ANT Factor + Cable loss + Atten loss + Extrapolation Factor - AMP gain  
Extrapolation Factor = 20\*Log (Test distance(3m) / Separate distance(300m))

NS : No-Signal  
Except for the above table : adequate margin data below the limits.

**Radiated Emission**  
**(Above 30 MHz)**

Report No. 13226969H  
Test place Ise EMC Lab.  
Semi Anechoic Chamber No.1  
Date May 2, 2020  
Temperature / Humidity 24 deg. C / 41 % RH  
Engineer Ken Fujita  
Mode Mode 3

FREQ [MHz]	Reading (3m) [dBμV]	Reading (10m) [dBμV]	ANT Factor [dB/m]	AMP gain [dB]	Atten + Cable loss [dB]	Extrapolation Factor [dB]	Result (300 m) [dBμV/m]	Limit (300 m) [dBμV/m]	Margin [dB]	Antenna Polarization
30.844	22.3	NS	18.0	38.8	7.4	-40.0	-31.1	23.5	54.6	Horizontal
47.063	30.7	NS	12.1	38.8	7.7	-40.0	-28.3	23.5	51.8	Horizontal
83.396	31.3	NS	7.4	38.9	8.4	-40.0	-31.9	23.5	55.4	Horizontal
156.485	29.7	NS	15.2	38.9	9.3	-40.0	-24.8	23.5	48.3	Horizontal
309.931	28.6	NS	13.8	38.7	10.8	-40.0	-25.5	23.5	49.0	Horizontal
388.068	30.8	NS	15.4	38.5	11.4	-40.0	-20.9	23.5	44.4	Horizontal
30.844	24.4	NS	18.0	38.8	7.4	-40.0	-29.0	23.5	52.5	Vertical
47.063	30.1	NS	12.1	38.8	7.7	-40.0	-28.9	23.5	52.4	Vertical
83.396	31.3	NS	7.4	38.9	8.4	-40.0	-31.9	23.5	55.4	Vertical
156.485	29.8	NS	15.2	38.9	9.3	-40.0	-24.7	23.5	48.2	Vertical
309.931	29.7	NS	13.8	38.7	10.8	-40.0	-24.5	23.5	48.0	Vertical
388.068	31.1	NS	15.4	38.5	11.4	-40.0	-20.6	23.5	44.1	Vertical

CALCULATION(Result) : Reading + ANT Factor + Cable loss + Atten loss + Extrapolation Factor - AMP gain  
Extrapolation Factor = 20\*Log (Test distance(3m) / Separate distance(300m))

NS : No-Signal

Except for the above table : adequate margin data below the limits.

**Radiated Emission**  
**(Above 30 MHz)**

Report No. 13226969H  
Test place Ise EMC Lab.  
Semi Anechoic Chamber No.1  
Date May 2, 2020  
Temperature / Humidity 24 deg. C / 41 % RH  
Engineer Ken Fujita  
Mode Mode 4

FREQ [MHz]	Reading (3m) [dBμV]	Reading (10m) [dBμV]	ANT Factor [dB/m]	AMP gain [dB]	Atten + Cable loss [dB]	Extrapolation Factor [dB]	Result (300 m) [dBμV/m]	Limit (300 m) [dBμV/m]	Margin [dB]	Antenna Polarization
33.983	22.7	NS	16.9	38.8	7.5	-40.0	-31.7	23.5	55.2	Horizontal
54.182	34.4	NS	9.6	38.8	7.9	-40.0	-27.0	23.5	50.5	Horizontal
69.356	36.7	NS	6.5	38.9	8.1	-40.0	-27.6	23.5	51.1	Horizontal
83.017	34.4	NS	7.3	38.9	8.4	-40.0	-28.8	23.5	52.3	Horizontal
263.862	31.3	NS	12.5	38.8	10.4	-40.0	-24.6	23.5	48.1	Horizontal
336.488	24.4	NS	14.8	38.6	11.0	-40.0	-28.4	23.5	51.9	Horizontal
33.983	23.2	NS	16.9	38.8	7.5	-40.0	-31.2	23.5	54.7	Vertical
54.182	32.7	NS	9.6	38.8	7.9	-40.0	-28.7	23.5	52.2	Vertical
69.356	33.5	NS	6.5	38.9	8.1	-40.0	-30.8	23.5	54.3	Vertical
83.017	32.2	NS	7.3	38.9	8.4	-40.0	-31.0	23.5	54.5	Vertical
263.862	31.2	NS	12.5	38.8	10.4	-40.0	-24.7	23.5	48.2	Vertical
336.488	25.4	NS	14.8	38.6	11.0	-40.0	-27.4	23.5	50.9	Vertical

CALCULATION(Result) : Reading + ANT Factor + Cable loss + Atten loss + Extrapolation Factor - AMP gain  
Extrapolation Factor = 20\*Log (Test distance(3m) / Separate distance(300m))

NS : No-Signal

Except for the above table : adequate margin data below the limits.

**Radiated Emission**  
**(Above 30 MHz)**

Report No. 13226969H  
Test place Ise EMC Lab.  
Semi Anechoic Chamber No.1  
Date May 2, 2020  
Temperature / Humidity 24 deg. C / 41 % RH  
Engineer Ken Fujita  
Mode Mode 5

FREQ [MHz]	Reading (3m) [dBμV]	Reading (10m) [dBμV]	ANT Factor [dB/m]	AMP gain [dB]	Atten + Cable loss [dB]	Extrapolation Factor [dB]	Result (300 m) [dBμV/m]	Limit (300 m) [dBμV/m]	Margin [dB]	Antenna Polarization
33.915	25.6	NS	17.0	38.8	7.5	-40.0	-28.8	23.5	52.3	Horizontal
46.803	29.5	NS	12.2	38.8	7.7	-40.0	-29.4	23.5	52.9	Horizontal
99.487	30.1	NS	10.0	39.0	8.6	-40.0	-30.2	23.5	53.7	Horizontal
177.340	31.3	NS	16.0	38.9	9.5	-40.0	-22.0	23.5	45.5	Horizontal
282.713	27.9	NS	13.4	38.8	10.6	-40.0	-26.9	23.5	50.4	Horizontal
380.597	29.5	NS	15.2	38.5	11.4	-40.0	-22.4	23.5	45.9	Horizontal
33.915	24.4	NS	17.0	38.8	7.5	-40.0	-30.0	23.5	53.5	Vertical
46.803	29.0	NS	12.2	38.8	7.7	-40.0	-29.9	23.5	53.4	Vertical
99.487	30.2	NS	10.0	39.0	8.6	-40.0	-30.1	23.5	53.6	Vertical
177.340	31.6	NS	16.0	38.9	9.5	-40.0	-21.8	23.5	45.3	Vertical
282.713	28.5	NS	13.4	38.8	10.6	-40.0	-26.3	23.5	49.8	Vertical
380.597	30.3	NS	15.2	38.5	11.4	-40.0	-21.7	23.5	45.2	Vertical

CALCULATION(Result) : Reading + ANT Factor + Cable loss + Atten loss + Extrapolation Factor - AMP gain  
Extrapolation Factor = 20\*Log (Test distance(3m) / Separate distance(300m))

NS : No-Signal

Except for the above table : adequate margin data below the limits.

**UL Japan, Inc.**

**Ise EMC Lab.**

4383-326 Asama-cho, Ise-shi, Mie-ken 516-0021 JAPAN

Telephone : +81 596 24 8999

Facsimile : +81 596 24 8124

**Radiated Emission**  
**(Above 30 MHz)**

Report No. 13226969H  
Test place Ise EMC Lab.  
Semi Anechoic Chamber No.1  
Date May 2, 2020  
Temperature / Humidity 24 deg. C / 41 % RH  
Engineer Ken Fujita  
Mode Mode 6

FREQ [MHz]	Reading (3m) [dBμV]	Reading (10m) [dBμV]	ANT Factor [dB/m]	AMP gain [dB]	Atten + Cable loss [dB]	Extrapolation Factor [dB]	Result (300 m) [dBμV/m]	Limit (300 m) [dBμV/m]	Margin [dB]	Antenna Polarization
31.773	26.7	NS	17.8	38.8	7.4	-40.0	-26.9	23.5	50.4	Horizontal
58.762	30.3	NS	8.1	38.8	7.9	-40.0	-32.5	23.5	56.0	Horizontal
98.601	28.9	NS	9.9	38.9	8.6	-40.0	-31.6	23.5	55.1	Horizontal
158.589	32.3	NS	15.3	38.9	9.3	-40.0	-22.1	23.5	45.6	Horizontal
295.945	30.3	NS	13.5	38.7	10.7	-40.0	-24.3	23.5	47.8	Horizontal
380.622	30.2	NS	15.2	38.5	11.4	-40.0	-21.8	23.5	45.3	Horizontal
31.773	27.7	NS	17.8	38.8	7.4	-40.0	-25.9	23.5	49.4	Vertical
58.762	31.0	NS	8.1	38.8	7.9	-40.0	-31.8	23.5	55.3	Vertical
98.601	29.0	NS	9.9	38.9	8.6	-40.0	-31.5	23.5	55.0	Vertical
158.589	32.0	NS	15.3	38.9	9.3	-40.0	-22.4	23.5	45.9	Vertical
295.945	30.2	NS	13.5	38.7	10.7	-40.0	-24.3	23.5	47.8	Vertical
380.622	30.2	NS	15.2	38.5	11.4	-40.0	-21.8	23.5	45.3	Vertical

CALCULATION(Result) : Reading + ANT Factor + Cable loss + Atten loss + Extrapolation Factor - AMP gain  
Extrapolation Factor = 20\*Log (Test distance(3m) / Separate distance(300m))

NS : No-Signal

Except for the above table : adequate margin data below the limits.

**Radiated Emission**  
**(Above 30 MHz)**

Report No. 13226969H  
Test place Ise EMC Lab.  
Semi Anechoic Chamber No.1  
Date May 2, 2020  
Temperature / Humidity 24 deg. C / 41 % RH  
Engineer Ken Fujita  
Mode Mode 7

FREQ [MHz]	Reading (3m) [dBμV]	Reading (10m) [dBμV]	ANT Factor [dB/m]	AMP gain [dB]	Atten + Cable loss [dB]	Extrapolation Factor [dB]	Result (300 m) [dBμV/m]	Limit (300 m) [dBμV/m]	Margin [dB]	Antenna Polarization
30.844	24.3	NS	18.0	38.8	7.4	-40.0	-29.1	23.5	52.6	Horizontal
47.063	31.1	NS	12.1	38.8	7.7	-40.0	-27.9	23.5	51.4	Horizontal
83.396	32.3	NS	7.4	38.9	8.4	-40.0	-30.9	23.5	54.4	Horizontal
156.485	30.2	NS	15.2	38.9	9.3	-40.0	-24.3	23.5	47.8	Horizontal
309.931	30.0	NS	13.8	38.7	10.8	-40.0	-24.1	23.5	47.6	Horizontal
388.068	30.7	NS	15.4	38.5	11.4	-40.0	-21.0	23.5	44.5	Horizontal
30.844	25.3	NS	18.0	38.8	7.4	-40.0	-28.1	23.5	51.6	Vertical
47.063	30.9	NS	12.1	38.8	7.7	-40.0	-28.1	23.5	51.6	Vertical
83.396	32.2	NS	7.4	38.9	8.4	-40.0	-31.0	23.5	54.5	Vertical
156.485	30.1	NS	15.2	38.9	9.3	-40.0	-24.3	23.5	47.8	Vertical
309.931	29.2	NS	13.8	38.7	10.8	-40.0	-25.0	23.5	48.5	Vertical
388.068	30.1	NS	15.4	38.5	11.4	-40.0	-21.6	23.5	45.1	Vertical

CALCULATION(Result) : Reading + ANT Factor + Cable loss + Atten loss + Extrapolation Factor - AMP gain  
Extrapolation Factor = 20\*Log (Test distance(3m) / Separate distance(300m))

NS : No-Signal

Except for the above table : adequate margin data below the limits.

**Radiated Emission**  
**(Above 30 MHz)**

Report No. 13226969H  
Test place Ise EMC Lab.  
Semi Anechoic Chamber No.1  
Date May 2, 2020  
Temperature / Humidity 24 deg. C / 41 % RH  
Engineer Ken Fujita  
Mode Mode 8

FREQ [MHz]	Reading (3m) [dBμV]	Reading (10m) [dBμV]	ANT Factor [dB/m]	AMP gain [dB]	Atten + Cable loss [dB]	Extrapolation Factor [dB]	Result (300 m) [dBμV/m]	Limit (300 m) [dBμV/m]	Margin [dB]	Antenna Polarization
33.208	24.3	NS	17.2	38.8	7.4	-40.0	-29.9	23.5	53.4	Horizontal
45.987	29.4	NS	12.5	38.8	7.7	-40.0	-29.2	23.5	52.7	Horizontal
81.301	28.9	NS	7.1	38.9	8.3	-40.0	-34.6	23.5	58.1	Horizontal
154.718	31.2	NS	15.1	38.9	9.3	-40.0	-23.3	23.5	46.8	Horizontal
301.365	32.3	NS	13.6	38.7	10.7	-40.0	-22.1	23.5	45.6	Horizontal
373.587	31.3	NS	15.1	38.6	11.3	-40.0	-20.9	23.5	44.4	Horizontal
33.208	24.4	NS	17.2	38.8	7.4	-40.0	-29.8	23.5	53.3	Vertical
45.987	30.1	NS	12.5	38.8	7.7	-40.0	-28.5	23.5	52.0	Vertical
81.301	31.1	NS	7.1	38.9	8.3	-40.0	-32.4	23.5	55.9	Vertical
154.718	31.3	NS	15.1	38.9	9.3	-40.0	-23.2	23.5	46.7	Vertical
301.365	32.2	NS	13.6	38.7	10.7	-40.0	-22.2	23.5	45.7	Vertical
373.587	32.3	NS	15.1	38.6	11.3	-40.0	-19.8	23.5	43.3	Vertical

CALCULATION(Result) : Reading + ANT Factor + Cable loss + Atten loss + Extrapolation Factor - AMP gain  
Extrapolation Factor = 20\*Log (Test distance(3m) / Separate distance(300m))

NS : No-Signal

Except for the above table : adequate margin data below the limits.

**Radiated Emission**  
**(Above 30 MHz)**

Report No. 13226969H  
Test place Ise EMC Lab.  
Semi Anechoic Chamber No.1  
Date May 2, 2020  
Temperature / Humidity 24 deg. C / 41 % RH  
Engineer Ken Fujita  
Mode Mode 9

FREQ [MHz]	Reading (3m) [dBμV]	Reading (10m) [dBμV]	ANT Factor [dB/m]	AMP gain [dB]	Atten + Cable loss [dB]	Extrapolation Factor [dB]	Result (300 m) [dBμV/m]	Limit (300 m) [dBμV/m]	Margin [dB]	Antenna Polarization
32.857	29.9	NS	17.3	38.8	7.4	-40.0	-24.2	23.5	47.7	Horizontal
46.699	31.3	NS	12.2	38.8	7.7	-40.0	-27.6	23.5	51.1	Horizontal
82.332	29.9	NS	7.2	38.9	8.3	-40.0	-33.4	23.5	56.9	Horizontal
122.732	30.2	NS	13.0	39.0	8.9	-40.0	-26.9	23.5	50.4	Horizontal
295.362	30.2	NS	13.5	38.7	10.7	-40.0	-24.3	23.5	47.8	Horizontal
382.114	31.3	NS	15.2	38.5	11.4	-40.0	-20.6	23.5	44.1	Horizontal
32.857	30.1	NS	17.3	38.8	7.4	-40.0	-24.0	23.5	47.5	Vertical
46.699	30.3	NS	12.2	38.8	7.7	-40.0	-28.6	23.5	52.1	Vertical
82.332	32.7	NS	7.2	38.9	8.3	-40.0	-30.7	23.5	54.2	Vertical
122.732	31.7	NS	13.0	39.0	8.9	-40.0	-25.3	23.5	48.8	Vertical
295.362	30.2	NS	13.5	38.7	10.7	-40.0	-24.4	23.5	47.9	Vertical
382.114	30.3	NS	15.2	38.5	11.4	-40.0	-21.7	23.5	45.2	Vertical

CALCULATION(Result) : Reading + ANT Factor + Cable loss + Atten loss + Extrapolation Factor - AMP gain  
Extrapolation Factor = 20\*Log (Test distance(3m) / Separate distance(300m))

NS : No-Signal

Except for the above table : adequate margin data below the limits.

**Radiated Emission**  
**(Above 30 MHz)**

Report No. 13226969H  
Test place Ise EMC Lab.  
Semi Anechoic Chamber No.1  
Date May 2, 2020  
Temperature / Humidity 24 deg. C / 41 % RH  
Engineer Ken Fujita  
Mode Mode 10

FREQ [MHz]	Reading (3m) [dBμV]	Reading (10m) [dBμV]	ANT Factor [dB/m]	AMP gain [dB]	Atten + Cable loss [dB]	Extrapolation Factor [dB]	Result (300 m) [dBμV/m]	Limit (300 m) [dBμV/m]	Margin [dB]	Antenna Polarization
31.752	31.1	NS	17.8	38.8	7.4	-40.0	-22.5	23.5	46.0	Horizontal
45.422	31.7	NS	12.7	38.8	7.7	-40.0	-26.8	23.5	50.3	Horizontal
72.254	27.8	NS	6.4	38.9	8.2	-40.0	-36.5	23.5	60.0	Horizontal
98.197	24.4	NS	9.8	38.9	8.6	-40.0	-36.3	23.5	59.8	Horizontal
305.216	29.3	NS	13.7	38.7	10.8	-40.0	-25.0	23.5	48.5	Horizontal
377.960	30.2	NS	15.2	38.5	11.4	-40.0	-21.9	23.5	45.4	Horizontal
31.752	30.9	NS	17.8	38.8	7.4	-40.0	-22.7	23.5	46.2	Vertical
45.422	31.1	NS	12.7	38.8	7.7	-40.0	-27.4	23.5	50.9	Vertical
72.254	28.9	NS	6.4	38.9	8.2	-40.0	-35.4	23.5	58.9	Vertical
98.197	26.4	NS	9.8	38.9	8.6	-40.0	-34.3	23.5	57.8	Vertical
305.216	25.1	NS	13.7	38.7	10.8	-40.0	-29.2	23.5	52.7	Vertical
377.960	30.2	NS	15.2	38.5	11.4	-40.0	-21.8	23.5	45.3	Vertical

CALCULATION(Result) : Reading + ANT Factor + Cable loss + Atten loss + Extrapolation Factor - AMP gain  
Extrapolation Factor = 20\*Log (Test distance(3m) / Separate distance(300m))

NS : No-Signal

Except for the above table : adequate margin data below the limits.

**Radiated Emission**  
**(Above 30 MHz)**

Report No. 13226969H  
Test place Ise EMC Lab.  
Semi Anechoic Chamber No.1  
Date May 2, 2020  
Temperature / Humidity 24 deg. C / 41 % RH  
Engineer Ken Fujita  
Mode Mode 11

FREQ [MHz]	Reading (3m) [dBμV]	Reading (10m) [dBμV]	ANT Factor [dB/m]	AMP gain [dB]	Atten + Cable loss [dB]	Extrapolation Factor [dB]	Result (300 m) [dBμV/m]	Limit (300 m) [dBμV/m]	Margin [dB]	Antenna Polarization
33.921	23.6	NS	17.0	38.8	7.5	-40.0	-30.8	23.5	54.3	Horizontal
48.561	31.1	NS	11.5	38.8	7.8	-40.0	-28.4	23.5	51.9	Horizontal
70.094	31.8	NS	6.5	38.9	8.1	-40.0	-32.5	23.5	56.0	Horizontal
149.214	25.6	NS	14.9	38.9	9.2	-40.0	-29.3	23.5	52.8	Horizontal
275.434	32.0	NS	13.2	38.8	10.5	-40.0	-23.2	23.5	46.7	Horizontal
320.863	32.6	NS	14.2	38.7	10.9	-40.0	-21.0	23.5	44.5	Horizontal
33.921	24.1	NS	17.0	38.8	7.5	-40.0	-30.3	23.5	53.8	Vertical
48.561	31.6	NS	11.5	38.8	7.8	-40.0	-27.9	23.5	51.4	Vertical
70.094	31.4	NS	6.5	38.9	8.1	-40.0	-32.8	23.5	56.3	Vertical
149.214	26.5	NS	14.9	38.9	9.2	-40.0	-28.4	23.5	51.9	Vertical
275.434	32.2	NS	13.2	38.8	10.5	-40.0	-22.9	23.5	46.4	Vertical
320.863	32.2	NS	14.2	38.7	10.9	-40.0	-21.4	23.5	44.9	Vertical

CALCULATION(Result) : Reading + ANT Factor + Cable loss + Atten loss + Extrapolation Factor - AMP gain  
Extrapolation Factor = 20\*Log (Test distance(3m) / Separate distance(300m))

NS : No-Signal

Except for the above table : adequate margin data below the limits.

## **APPENDIX 2: Test instruments**

### **Test equipment**

Test Item	Local ID	LIMS ID	Description	Manufacturer	Model	Serial	Last Calibration Date	Cal Int
RE	MAEC-01	141998	AC1 Semi Anechoic Chamber(NSA)	TDK	Semi Anechoic Chamber 10m	DA-06881	06/18/2018	24
RE	MOS-27	141566	Thermo-Hygrometer	CUSTOM	CTH-201	A08Q26	01/07/2020	12
RE	MMM-03	141530	Digital Tester	Fluke Corporation	FLUKE 26-3	78030621	08/20/2019	12
RE	MJM-25	142226	Measure	KOMELON	KMC-36	-	-	-
RE	COTS-MEMI-02	178648	EMI measurement program	TSJ	TEPTO-DV	-	-	-
RE	MCC-03	141215	Coaxial Cable	Fujikura/Suhner/TSJ	5D-2W/3D-2W/ RG400u/ RFM-E421(SW)	-/01068(Switcher)	06/27/2019	12
RE	MLPA-01	141254	Loop Antenna	Rohde & Schwarz	HFH2-Z2	100017	10/04/2019	12
RE	MCC-143	141413	Coaxial Cable	UL Japan	-	-	06/07/2019	12
RE	MPA-14	141583	Pre Amplifier	SONOMA INSTRUMENT	310	260833	02/18/2020	12
RE	MAT-08	141213	Attenuator(6dB)	Weinschel Corp	2	BK7971	11/14/2019	12
RE	MTR-09	141950	EMI Test Receiver	Rohde & Schwarz	ESU26	100412	06/27/2019	12
RE	MLA-20	141264	Logperiodic Antenna(200-1000MHz)	Schwarzbeck Mess - Elektronik	VUSLP9111B	9111B-189	08/23/2019	12
RE	KBA-05	141198	Biconical Antenna	Schwarzbeck Mess - Elektronik	VHA9103+BBA9106	2513	08/23/2019	12
RE	MCC-02	141350	Coaxial Cable	Suhner/storm/Agilent/TSJ	-	-	06/27/2019	12
RE	MPA-19	141585	Pre Amplifier	MITEQ	MLA-10K01-B01-35	1237616	02/10/2020	12

\*Hyphens for Last Calibration Date and Cal Int (month) are instruments that Calibration is not required (e.g. software), or instruments checked in advance before use.

The expiration date of the calibration is the end of the expired month.

As for some calibrations performed after the tested dates, those test equipment have been controlled by means of an unbroken chains of calibrations.

All equipment is calibrated with valid calibrations. Each measurement data is traceable to the national or international standards.

Test item:

RE: Radiated emission

**UL Japan, Inc.**

**Ise EMC Lab.**

4383-326 Asama-cho, Ise-shi, Mie-ken 516-0021 JAPAN

Telephone : +81 596 24 8999

Facsimile : +81 596 24 8124