



RADIO TEST REPORT

Test Report No. : 13226969H-B-R1

Applicant : Panasonic Corporation
Type of EUT : Wireless Charger
Model Number of EUT : AT2001
FCC ID : ACJ932AT2001
Test regulation : FCC Part 15 Subpart C: 2020
Test Result : Complied (Refer to SECTION 3.2)

1. This test report shall not be reproduced in full or partial, without the written approval of UL Japan, Inc.
2. The results in this report apply only to the sample tested.
3. This sample tested is in compliance with above regulation.
4. The test results in this report are traceable to the national or international standards.
5. This test report covers Radio technical requirements. It does not cover administrative issues such as Manual or non-Radio test related Requirements. (if applicable)
6. The all test items in this test report are conducted by UL Japan, Inc. Ise EMC Lab.
7. This test report must not be used by the customer to claim product certification, approval, or endorsement by NVLAP, NIST, or any agency of the U.S. Government.
8. The information provided from the customer for this report is identified in SECTION 1.
9. This report is a revised version of 13226969H-B. 13226969H-B is replaced with this report.

Date of test: April 1 to May 17, 2020

Representative test engineer: T. Nakagawa
 Tomohisa Nakagawa
 Engineer
 Consumer Technology Division

Approved by: T. Takayama
 Tsubasa Takayama
 Leader
 Consumer Technology Division



This laboratory is accredited by the NVLAP LAB CODE 200572-0, U.S.A. The tests reported herein have been performed in accordance with its terms of accreditation.
 *As for the range of Accreditation in NVLAP, you may refer to the WEB address,
http://japan.ul.com/resources/emc_accredited/

- This report contains data that are not covered by the NVLAP accreditation.
 There is no testing item of "Non-accreditation".

REVISION HISTORY

Original Test Report No.: 13226969H-B

Revision	Test report No.	Date	Page revised	Contents
- (Original)	13226969H-B	May 25, 2020	-	-
1	13226969H-B-R1	June 11, 2020	P.5	Correction of Operating Frequency in Radio Specification of Clause 2.2; From 127.5 kHz To 120.3 kHz / 127.0 kHz / 127.5 kHz / 126.515 kHz to 128.549 kHz
1	13226969H-B-R1	June 11, 2020	P.5	Deletion of Frequency Band from Radio Specification of Clause 2.2.
1	13226969H-B-R1	June 11, 2020	P.6	Correction of the FCC Part 15.31 (e) description in Section 3.2; from This test was performed with the New Battery (DC 12 V) and the constant voltage was supplied to this EUT during the tests. Therefore, this EUT complies with the requirement. to This EUT constantly provides the stable voltage to RF part through the regulator regardless of input voltage. Therefore, this EUT complies with the requirement.

UL Japan, Inc.

Ise EMC Lab.

4383-326 Asama-cho, Ise-shi, Mie-ken 516-0021 JAPAN

Telephone : +81 596 24 8999

Facsimile : +81 596 24 8124

Reference: Abbreviations (Including words undescribed in this report)

A2LA	The American Association for Laboratory Accreditation	MCS	Modulation and Coding Scheme
AC	Alternating Current	MRA	Mutual Recognition Arrangement
AFH	Adaptive Frequency Hopping	N/A	Not Applicable
AM	Amplitude Modulation	NIST	National Institute of Standards and Technology
Amp, AMP	Amplifier	NS	No signal detect.
ANSI	American National Standards Institute	NSA	Normalized Site Attenuation
Ant, ANT	Antenna	NVLAP	National Voluntary Laboratory Accreditation Program
AP	Access Point	OBW	Occupied Band Width
ASK	Amplitude Shift Keying	OFDM	Orthogonal Frequency Division Multiplexing
Atten., ATT	Attenuator	P/M	Power meter
AV	Average	PCB	Printed Circuit Board
BPSK	Binary Phase-Shift Keying	PER	Packet Error Rate
BR	Bluetooth Basic Rate	PHY	Physical Layer
BT	Bluetooth	PK	Peak
BT LE	Bluetooth Low Energy	PN	Pseudo random Noise
BW	BandWidth	PRBS	Pseudo-Random Bit Sequence
Cal Int	Calibration Interval	PSD	Power Spectral Density
CCK	Complementary Code Keying	QAM	Quadrature Amplitude Modulation
Ch., CH	Channel	QP	Quasi-Peak
CISPR	Comite International Special des Perturbations Radioelectriques	QPSK	Quadri-Phase Shift Keying
CW	Continuous Wave	RBW	Resolution Band Width
DBPSK	Differential BPSK	RDS	Radio Data System
DC	Direct Current	RE	Radio Equipment
D-factor	Distance factor	RF	Radio Frequency
DFS	Dynamic Frequency Selection	RMS	Root Mean Square
DQPSK	Differential QPSK	RSS	Radio Standards Specifications
DSSS	Direct Sequence Spread Spectrum	Rx	Receiving
EDR	Enhanced Data Rate	SA, S/A	Spectrum Analyzer
EIRP, e.i.r.p.	Equivalent Isotropically Radiated Power	SG	Signal Generator
EMC	ElectroMagnetic Compatibility	SVSWR	Site-Voltage Standing Wave Ratio
EMI	ElectroMagnetic Interference	TR	Test Receiver
EN	European Norm	Tx	Transmitting
ERP, e.r.p.	Effective Radiated Power	VBW	Video BandWidth
EU	European Union	Vert.	Vertical
EUT	Equipment Under Test	WLAN	Wireless LAN
Fac.	Factor		
FCC	Federal Communications Commission		
FHSS	Frequency Hopping Spread Spectrum		
FM	Frequency Modulation		
Freq.	Frequency		
FSK	Frequency Shift Keying		
GFSK	Gaussian Frequency-Shift Keying		
GNSS	Global Navigation Satellite System		
GPS	Global Positioning System		
Hori.	Horizontal		
ICES	Interference-Causing Equipment Standard		
IEC	International Electrotechnical Commission		
IEEE	Institute of Electrical and Electronics Engineers		
IF	Intermediate Frequency		
ILAC	International Laboratory Accreditation Conference		
ISED	Innovation, Science and Economic Development Canada		
ISO	International Organization for Standardization		
JAB	Japan Accreditation Board		
LAN	Local Area Network		
LIMS	Laboratory Information Management System		

UL Japan, Inc.

Ise EMC Lab.

4383-326 Asama-cho, Ise-shi, Mie-ken 516-0021 JAPAN

Telephone : +81 596 24 8999

Facsimile : +81 596 24 8124

CONTENTS	PAGE
SECTION 1: Customer information	5
SECTION 2: Equipment under test (EUT).....	5
SECTION 3: Test specification, procedures & results	6
SECTION 4: Operation of EUT during testing.....	9
SECTION 5: Radiated emission (Fundamental and Spurious Emission).....	12
SECTION 6: -26dB Bandwidth.....	15
SECTION 7: 99% Occupied Bandwidth.....	15
APPENDIX 1: Test data	16
Radiated Emission below 30 MHz (Fundamental and Spurious Emission)	16
Radiated Emission above 30 MHz (Spurious Emission).....	27
-26 dB Bandwidth and 99% Occupied Bandwidth	40
APPENDIX 2: Test instruments	51
APPENDIX 3: Photographs of test setup.....	52
Radiated Emission.....	52
Worst Case Position	54

UL Japan, Inc.

Ise EMC Lab.

4383-326 Asama-cho, Ise-shi, Mie-ken 516-0021 JAPAN

Telephone : +81 596 24 8999

Facsimile : +81 596 24 8124

SECTION 1: Customer information

Company Name : Panasonic Corporation
Address : 4261, Ikonobe-cho, Tsuzuki-ku, Yokohama-shi, Kanagawa-ken, 224-8520, Japan
Telephone Number : +81-50-3689-7112
Facsimile Number : +81-45-931-0806
Contact Person : Takahisa Sakai

The information provided from the customer is as follows;

- Applicant, Type of EUT, Model Number of EUT, FCC ID on the cover and other relevant pages
 - Operating/Test Mode(s) (Mode(s)) on all the relevant pages
 - SECTION 1: Customer information
 - SECTION 2: Equipment under test (EUT) other than the Receipt Date
 - SECTION 4: Operation of EUT. during testing
- * The laboratory is exempted from liability of any test results affected from the above information in SECTION 2 and 4.

SECTION 2: Equipment under test (EUT)

2.1 Identification of EUT

Type : Wireless Charger
Model Number : AT2001
Serial Number : Refer to SECTION 4.2
Rating : DC 10.5 V to 16.0 V
Receipt Date : March 18, 2020
Country of Mass-production : Japan, China, Czech Republic, and Thailand
Condition : Production prototype
(Not for Sale: This sample is equivalent to mass-produced items.)
Modification : No Modification by the test lab.

2.2 Product Description

Model: AT2001 (referred to as the EUT in this report) is a Wireless Charger.

Feature of EUT : Press the supply switch of the wireless charger. Each press the power supply switch it on/off.
When turned the hybrid system off, the state of the power supply for wireless charger is memorized.
Place the charging side of the portable device (etc. mobile phone) down.
When charging, the operation indicator light (orange) comes on.
If charging is not occurring, try placing the portable device as close to the center of the charging area as possible.
When charging is complete, the operation indicator light (green) comes on.

Radio Specification

Operating Frequency : 120.3 kHz / 127.0 kHz / 127.5 kHz / 126.515 kHz to 128.549 kHz
Rated Output Power : 5 W / 10 W
Coil system : Single Coil
Charging distance : Contact
Clock frequency (maximum) : 8 MHz

UL Japan, Inc.

Ise EMC Lab.

4383-326 Asama-cho, Ise-shi, Mie-ken 516-0021 JAPAN

Telephone : +81 596 24 8999

Facsimile : +81 596 24 8124

SECTION 3: Test specification, procedures & results

3.1 Test Specification

Test Specification : FCC Part 15 Subpart C
FCC Part 15 final revised on April 1, 2020 and effective June 1, 2020 except 15.258

Title : FCC 47CFR Part15 Radio Frequency Device Subpart C Intentional Radiators
Section 15.207 Conducted limits
Section 15.209 Radiated emission limits; general requirements.

* The revision does not affect the test result conducted before its effective date.

3.2 Procedures and results

Item	Test Procedure	Specification	Remarks	Deviation	Worst margin	Results	Remarks
Conducted Emission	<FCC> ANSI C63.10:2013 6 Standard test methods <ISED> RSS-Gen 8.8	<FCC> Section 15.207 <ISED> RSS-Gen 8.8	-	N/A	N/A	N/A	*1)
Electric Field Strength of Fundamental Emission	<FCC> ANSI C63.10:2013 6 Standard test methods <ISED> RSS-Gen 6.5, 6.12	<FCC> Section 15.209 <ISED> RSS-210 4.4 RSS-Gen 8.9	Radiated	N/A	22.2 dB 128.016 kHz 0 deg. PK with Duty factor	Complied a)	-
Electric Field Strength of Spurious Emission	<FCC> ANSI C63.10:2013 6 Standard test methods <ISED> RSS-Gen 6.5, 6.6, 6.13	<FCC> Section 15.209 <ISED> RSS-210 4.4 RSS-Gen 8.9	Radiated	N/A	14.5 dB 47.200 MHz, Vertical, QP	Complied a)	-
-26dB Bandwidth	<FCC> ANSI C63.10:2013 6 Standard test methods <ISED> -	<FCC> Reference data <ISED> -	Radiated	N/A	N/A	Complied b)	-

Note: UL Japan, Inc.'s EMI Work Procedures No. 13-EM-W0420 and 13-EM-W0422.

*1) The test is not applicable since the EUT is not the device that is designed to be connected to the public utility (AC) power line.

a) Refer to APPENDIX 1 (data of Radiated emission)

b) Refer to APPENDIX 1 (data of -26 dB Bandwidth)

Symbols:

Complied The data of this test item has enough margin, more than the measurement uncertainty.

Complied# The data of this test item meets the limits unless the measurement uncertainty is taken into consideration.

FCC Part 15.31 (e)

This EUT constantly provides the stable voltage to RF part through the regulator regardless of input voltage. Therefore, this EUT complies with the requirement.

FCC Part 15.203 Antenna requirement

It is impossible for end users to replace the antenna, because the antenna is mounted inside of the EUT. Therefore, the equipment complies with the antenna requirement of Section 15.203.

UL Japan, Inc.

Ise EMC Lab.

4383-326 Asama-cho, Ise-shi, Mie-ken 516-0021 JAPAN

Telephone : +81 596 24 8999

Facsimile : +81 596 24 8124

3.3 Addition to standard

Item	Test Procedure	Specification	Remarks	Deviation	Worst margin	Results
99 % Occupied Band Width	RSS-Gen 6.7	-	Radiated	N/A	N/A	-

Note: UL Japan, Inc.'s EMI Work Procedures No. 13-EM-W0420 and 13-EM-W0422.

Other than above, no addition, exclusion nor deviation has been made from the standard.

3.4 Uncertainty

There is no applicable rule of uncertainty in this applied standard. Therefore, the following results are derived depending on whether or not laboratory uncertainty is applied.

The following uncertainties have been calculated to provide a confidence level of 95% using a coverage factor k=2.

Radiated emission

Measurement distance	Frequency range	Uncertainty (+/-)	
3 m	9 kHz to 30 MHz	3.3 dB	
10 m		3.2 dB	
3 m	30 MHz to 200 MHz	(Horizontal)	4.8 dB
		(Vertical)	5.0 dB
	200 MHz to 1000 MHz	(Horizontal)	5.2 dB
		(Vertical)	6.3 dB
10 m	30 MHz to 200 MHz	(Horizontal)	4.8 dB
		(Vertical)	4.8 dB
	200 MHz to 1000 MHz	(Horizontal)	5.0 dB
		(Vertical)	5.0 dB

Antenna Terminal test

Test Item	Uncertainty (+/-)
-20dB Bandwidth / 99 % Occupied Bandwidth	0.96 %

UL Japan, Inc.

Ise EMC Lab.

4383-326 Asama-cho, Ise-shi, Mie-ken 516-0021 JAPAN

Telephone : +81 596 24 8999

Facsimile : +81 596 24 8124

3.5 Test Location

UL Japan, Inc. Ise EMC Lab.

*NVLAP Lab. code: 200572-0 / FCC Test Firm Registration Number: 199967 / ISED Lab Company Number: 2973C

4383-326 Asama-cho, Ise-shi, Mie-ken 516-0021 JAPAN

Telephone: +81 596 24 8999, Facsimile: +81 596 24 8124

Test site	Width x Depth x Height (m)	Size of reference ground plane (m) / horizontal conducting plane	Other rooms	Maximum measurement distance
No.1 semi-anechoic chamber	19.2 x 11.2 x 7.7	7.0 x 6.0	No.1 Power source room	10 m
No.2 semi-anechoic chamber	7.5 x 5.8 x 5.2	4.0 x 4.0	-	3 m
No.3 semi-anechoic chamber	12.0 x 8.5 x 5.9	6.8 x 5.75	No.3 Preparation room	3 m
No.3 shielded room	4.0 x 6.0 x 2.7	N/A	-	-
No.4 semi-anechoic chamber	12.0 x 8.5 x 5.9	6.8 x 5.75	No.4 Preparation room	3 m
No.4 shielded room	4.0 x 6.0 x 2.7	N/A	-	-
No.5 semi-anechoic chamber	6.0 x 6.0 x 3.9	6.0 x 6.0	-	-
No.5 measurement room	6.4 x 6.4 x 3.0	6.4 x 6.4	-	-
No.6 shielded room	4.0 x 4.5 x 2.7	4.0 x 4.5	-	-
No.6 measurement room	4.75 x 5.4 x 3.0	4.75 x 4.15	-	-
No.7 shielded room	4.7 x 7.5 x 2.7	4.7 x 7.5	-	-
No.8 measurement room	3.1 x 5.0 x 2.7	3.1 x 5.0	-	-
No.9 measurement room	8.8 x 4.6 x 2.8	2.4 x 2.4	-	-
No.11 measurement room	6.2 x 4.7 x 3.0	4.8 x 4.6	-	-

* Size of vertical conducting plane (for Conducted Emission test) : 2.0 x 2.0 m for No.1, No.2, No.3, and No.4 semi-anechoic chambers and No.3 and No.4 shielded rooms.

3.6 Test data, Test instruments, and Test set up

Refer to APPENDIX.

SECTION 4: Operation of EUT during testing

4.1 Operating Modes

Test mode	Remarks
1) Normal Operating mode (120.3 kHz / 5 W)	Mode 1
2) Normal Operating mode (127.5 kHz / 10 W)	Mode 2
3) Normal Operating mode (127.0 kHz / 5 W)	Mode 3
4) Normal Operating mode (127.627 kHz / 10 W)	Mode 4
5) Normal Operating mode (127.756 kHz / 10 W)	Mode 5
6) Normal Operating mode (128.016 kHz / 10 W)	Mode 6
7) Normal Operating mode (128.549 kHz / 10 W)	Mode 7
8) Normal Operating mode (127.373 kHz / 10 W)	Mode 8
9) Normal Operating mode (127.248 kHz / 10 W)	Mode 9
10) Normal Operating mode (126.999 kHz / 10 W)	Mode 10
11) Normal Operating mode (126.515 kHz / 10 W)	Mode 11
<p>* EUT was set by the software as follows; Software: WC2_0224_10S_GEN4.hex Version 0224 (Date: 2020.2.6, Storage location: EUT memory)</p> <p>*This setting of software is the worst case. Any conditions under the normal use do not exceed the condition of setting. In addition, end users cannot change the settings of the output power of the product.</p>	

Justification : The system was configured in typical fashion (as a user would normally use it) for testing.

UL Japan, Inc.

Ise EMC Lab.

4383-326 Asama-cho, Ise-shi, Mie-ken 516-0021 JAPAN

Telephone : +81 596 24 8999

Facsimile : +81 596 24 8124

4.2 Configuration and peripherals

[Mode 1 to 3]

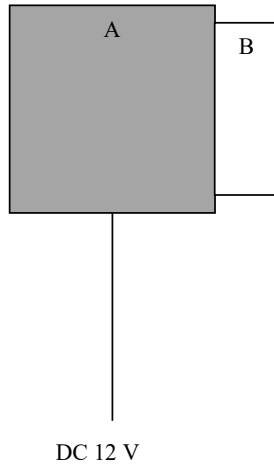

* Cabling and setup(s) were taken into consideration and test data was taken under worse case conditions.

Description of EUT and Support equipment

No.	Item	Model number	Serial number	Manufacturer	Remarks
A	Wireless Charger	AT2001	1.5S-003	Panasonic Corporation	EUT
B	Test Jig	PAS-JS100	103	Panasonic Corporation	-

*A and B communicates and charges via air interface.

List of cables used

No.	Name	Length (m)	Shield		Remark
			Cable	Connector	
1	Power Cable	2.3	Unshielded	Unshielded	-

UL Japan, Inc.

Ise EMC Lab.

4383-326 Asama-cho, Ise-shi, Mie-ken 516-0021 JAPAN

Telephone : +81 596 24 8999

Facsimile : +81 596 24 8124

[Mode 4 to 11]

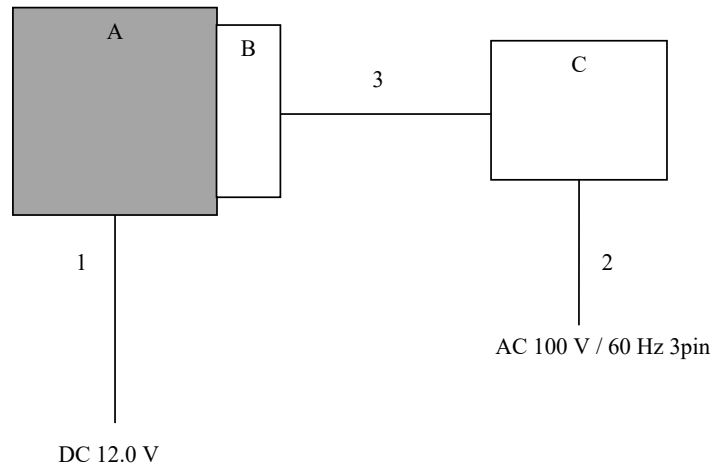

* Cabling and setup(s) were taken into consideration and test data was taken under worse case conditions.

Description of EUT and Support equipment

No.	Item	Model number	Serial number	Manufacturer	Remarks
A	Wireless Charger	AT2001	1.5S-003	Panasonic Corporation	EUT
B	Communication probe	-	-	nok9	-
C	Desk top PC	LP/MP/FOD	200134-1807	nok9	-

*A and B communicates and charges via air interface.

List of cables used

No.	Name	Length (m)	Shield		Remark
			Cable	Connector	
1	Power Cable	2.3	Unshielded	Unshielded	-
2	Power Cable	1.5	Unshielded	Unshielded	-
3	Communication cable	0.6	Shielded	Shielded	-

UL Japan, Inc.

Ise EMC Lab.

4383-326 Asama-cho, Ise-shi, Mie-ken 516-0021 JAPAN

Telephone : +81 596 24 8999

Facsimile : +81 596 24 8124

SECTION 5: Radiated emission (Fundamental and Spurious Emission)

Test Procedure

EUT was placed on a urethane platform of nominal size, 0.5 m by 1.0 m, raised 0.8 m above the conducting ground plane. The Radiated Electric Field Strength has been measured in a Semi Anechoic Chamber with a ground plane.

Frequency : From 9 kHz to 30 MHz

The EUT was rotated a full revolution in order to obtain the maximum value of the electric field intensity.

The measurements were performed for vertical polarization (antenna angle: 0 deg., 45 deg., 90 deg., and 135 deg.) and horizontal polarization.

*Refer to Figure 1 about Direction of the Loop Antenna.

Frequency: From 30 MHz to 1 GHz

The measuring antenna height varied between 1 and 4 m and EUT was rotated a full revolution in order to obtain the maximum value of the electric field intensity.

The measurements were performed for both vertical and horizontal antenna polarization.

The test was made with the detector (RBW / VBW) in the following table.

When using Spectrum analyzer, the test was made with adjusting span to zero by using peak hold.

Test Antennas are used as below;

Frequency	Below 30 MHz	30 MHz to 200 MHz	200 MHz to 1 GHz
Antenna Type	Loop	Biconical	Logperiodic

Frequency	From 9 kHz to 90 kHz and From 110 kHz to 150 kHz	From 90 kHz to 110 kHz	From 150 kHz to 490 kHz	From 490 kHz to 30 MHz	From 30 MHz to 1 GHz
Instrument used	Test Receiver				
Detector	PK / AV	QP	PK / AV	QP	QP
IF Bandwidth	200 Hz	200 Hz	9 kHz	9 kHz	120 kHz
Test Distance	3 m *1)	3 m *1)	3 m *1)	3 m *2)	3 m

*1) Distance Factor: $40 \times \log(3 \text{ m} / 300 \text{ m}) = -80 \text{ dB}$

*2) Distance Factor: $40 \times \log(3 \text{ m} / 30 \text{ m}) = -40 \text{ dB}$

Although these tests were performed other than open field test site, adequate comparison measurements were confirmed against 30 m open field test site. Therefore sufficient tests were made to demonstrate that the alternative site produces results that correlate with the ones of tests made in an open field based on KDB 414788.

These tests were performed in semi anechoic chamber. Therefore the measured level of emissions may be higher than if measurements were made without a ground plane.

However test results were confirmed to pass against standard limit.

UL Japan, Inc.

Ise EMC Lab.

4383-326 Asama-cho, Ise-shi, Mie-ken 516-0021 JAPAN

Telephone : +81 596 24 8999

Facsimile : +81 596 24 8124

[Test Setup]
Below 1 GHz

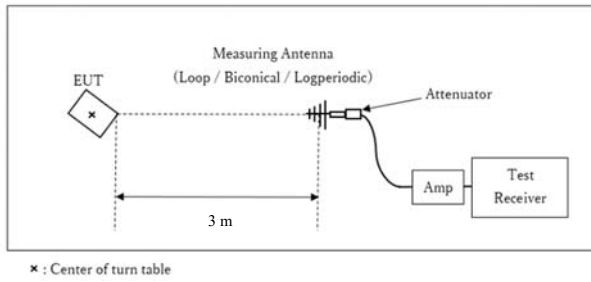

Test Distance: 3 m

- The carrier level and noise levels were confirmed at each position of X, Y and Z axes of EUT to see the position of maximum noise, and the test was made at the position that has the maximum noise.

The test results and limit are rounded off to one decimal place, so some differences might be observed.

Measurement range : 9 kHz - 1 GHz
Test data : APPENDIX 1
Test result : Pass

Date: April 1, 2020
April 16, 2020
May 13, 2020
May 14, 2020
May 17, 2020

Test engineer: Takeshi Hiyaji
Junya Okuno
Tomohisa Nakagawa
Ken Fujita
Junki Nagatomi

Figure 1: Direction of the Loop Antenna

Side View (Vertical)

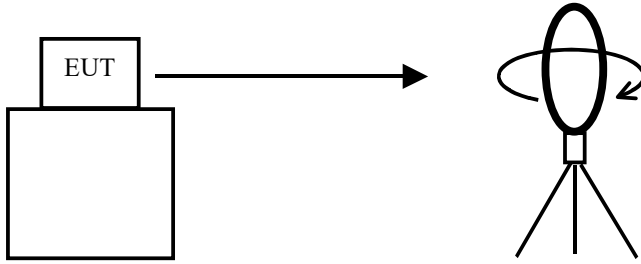

.....
Top View (Horizontal)

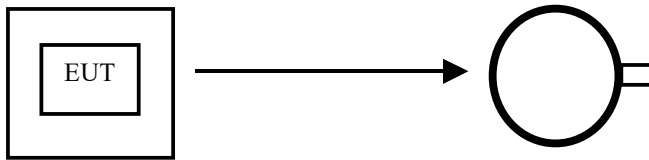

Antenna was not rotated.

.....
Top View (Vertical)

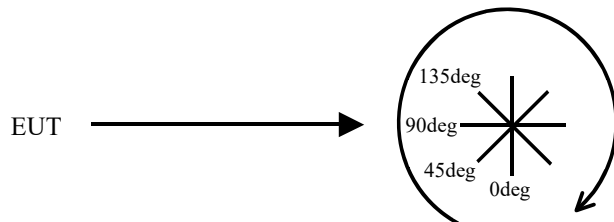

Front side: 0 deg.
Forward direction: clockwise

SECTION 6: -26dB Bandwidth

Test Procedure

The test was measured with a spectrum analyzer using a test fixture.

For the Mode 1 through 3 :

Test	Span	RBW	VBW	Sweep	Detector	Trace	Instrument used
-26 dB Bandwidth	100 kHz	10 kHz	Three times of RBW	Auto	Peak	Max Hold	Spectrum Analyzer

* Above settings are not followed by ANSI requirement, because signal is almost sine wave, the smaller RBW setting is, the narrower result is. So actual settings are 10kHz for RBW.

For the Mode other than 1 through 3 :

Test	Span	RBW	VBW	Sweep	Detector	Trace	Instrument used
-26 dB Bandwidth	Enough width to display emission skirts	1 to 5 % of OBW	Three times of RBW	Auto	Peak	Max Hold	Spectrum Analyzer

Test data : APPENDIX 1

Test result : Pass

SECTION 7: 99% Occupied Bandwidth

Test Procedure

The test was measured with a spectrum analyzer using a test fixture.

For the Mode 1 through 3 :

Test	Span	RBW	VBW	Sweep	Detector	Trace	Instrument used
99 % Occupied Bandwidth	Enough width to display emission skirts	10kHz	Three times of RBW	Auto	Peak *1)	Max Hold *1)	Spectrum Analyzer

*1) The measurement was performed with Peak detector, Max Hold since the duty cycle was not 100 %.

* Above settings are not followed by ANSI requirement, because signal is almost sine wave, the smaller RBW setting is, the narrower result is. So actual settings are 10kHz for RBW.

Peak hold was applied as Worst-case measurement.

For the Mode other than 1 through 3 :

Test	Span	RBW	VBW	Sweep	Detector	Trace	Instrument used
99 % Occupied Bandwidth	Enough width to display emission skirts	1 to 5 % of OBW	Three times of RBW	Auto	Peak *1)	Max Hold *1)	Spectrum Analyzer

*1) The measurement was performed with Peak detector, Max Hold since the duty cycle was not 100 %.

Peak hold was applied as Worst-case measurement.

Test data : APPENDIX 1

Test result : Pass

UL Japan, Inc.

Ise EMC Lab.

4383-326 Asama-cho, Ise-shi, Mie-ken 516-0021 JAPAN

Telephone : +81 596 24 8999

Facsimile : +81 596 24 8124

APPENDIX 1: Test data

Radiated Emission below 30 MHz (Fundamental and Spurious Emission)

Report No. 13226969H
Test place Ise EMC Lab.
Semi Anechoic Chamber No.1
Date 04/01/2020
Temperature / Humidity 21 deg. C / 52 % RH
Engineer Takeshi Hiyaji
Mode Mode 1 (5 W)

PK or QP

Ant Deg [deg] or Polarity [Hori/Vert]	Frequency [MHz]	Detector	Reading [dBuV]	Ant Factor [dB/m]	Loss [dB]	Gain [dB]	Duty Factor [dB]	Result [dBuV/m]	Limit dBuV/m	Margin [dB]	Remark
0deg	0.1203	PK	70.2	19.9	-74.0	32.1	-	-16.0	45.9	61.9	Fundamental
0deg	0.2406	PK	45.6	19.9	-74.0	32.1	-	-40.5	39.9	80.4	
0deg	0.3609	PK	49.1	19.9	-74.0	32.1	-	-37.1	36.4	73.5	
0deg	0.4812	PK	39.8	19.8	-73.9	32.1	-	-46.4	34.0	80.4	
0deg	0.6015	QP	39.1	19.8	-33.9	32.0	-	-7.1	32.0	39.1	
0deg	0.7218	QP	31.8	19.8	-33.9	32.0	-	-14.3	30.4	44.7	
0deg	0.8421	QP	35.1	19.8	-33.9	32.0	-	-11.0	29.1	40.1	
0deg	0.9624	QP	31.3	19.8	-33.8	32.0	-	-14.8	27.9	42.7	
0deg	1.0827	QP	33.0	19.8	-33.8	32.0	-	-13.1	26.9	40.0	
0deg	1.2030	QP	31.0	19.8	-33.8	32.0	-	-15.1	25.9	41.0	

Result = Reading + Ant Factor + Loss (Cable + Attenuator + Filter + D.Factor) - Gain(Amprifier)

PK with Duty factor

Ant Deg [deg]	Frequency [MHz]	Detector	Reading [dBuV]	Ant Factor [dB/m]	Loss [dB]	Gain [dB]	Duty Factor [dB]	Result [dBuV/m]	Limit dBuV/m	Margin [dB]	Remark
0deg	0.1203	PK	70.2	19.9	-74.0	32.1	0.0	-16.0	25.9	41.9	
0deg	0.2406	PK	45.6	19.9	-74.0	32.1	0.0	-40.5	19.9	60.4	
0deg	0.3609	PK	49.1	19.9	-74.0	32.1	0.0	-37.1	16.4	53.5	
0deg	0.4812	PK	39.8	19.8	-73.9	32.1	0.0	-46.4	14.0	60.4	

Result = Reading + Ant Factor + Loss (Cable + Attenuator + Filter + D.Factor) - Gain(Amprifier) + Duty factor *

* Since the peak emission result satisfied the average limit, duty factor was omitted.

Result of the fundamental emission at 3m without Distance factor

PK or QP

Ant Deg [deg]	Frequency [MHz]	Detector	Reading [dBuV]	Ant Factor [dB/m]	Loss [dB]	Gain [dB]	Duty Factor [dB]	Result [dBuV/m]	Limit dBuV/m	Margin [dB]	Remark
0deg	0.1203	PK	70.2	19.9	6.0	32.1	-	64.0	-	-	Fundamental

Result = Reading + Ant Factor + Loss (Cable+Attenuator+Filter) - Gain(Amprifier)

* Other frequency noises omitted in this report were not seen or had enough margin (more than 20 dB).

*The test result is rounded off to one or two decimal places, so some differences might be observed.

UL Japan, Inc.

Ise EMC Lab.

4383-326 Asama-cho, Ise-shi, Mie-ken 516-0021 JAPAN

Telephone : +81 596 24 8999

Facsimile : +81 596 24 8124

Radiated Emission below 30 MHz (Fundamental and Spurious Emission)

Report No. 13226969H
Test place Ise EMC Lab.
Semi Anechoic Chamber No.1
Date 04/01/2020
Temperature / Humidity 21 deg. C / 52 % RH
Engineer Takeshi Hiyaji
Mode Mode 2 (10 W)

PK or QP

Ant Deg [deg] or Polarity [Hori/Vert]	Frequency [MHz]	Detector	Reading [dBuV]	Ant Factor [dB/m]	Loss [dB]	Gain [dB]	Duty Factor [dB]	Result [dBuV/m]	Limit [dBuV/m]	Margin [dB]	Remark
0deg	0.12749	PK	77.8	19.9	-74.0	32.1	-	-8.4	45.4	53.8	Fundamental
0deg	0.25498	PK	48.7	19.9	-74.0	32.1	-	-37.5	39.4	76.9	
0deg	0.38247	PK	52.9	19.8	-73.9	32.1	-	-33.3	35.9	69.2	
0deg	0.50996	QP	37.1	19.8	-33.9	32.1	-	-9.1	33.5	42.6	
0deg	0.63745	QP	42.3	19.8	-33.9	32.0	-	-3.8	31.5	35.3	
0deg	0.76494	QP	37.0	19.8	-33.9	32.0	-	-9.1	29.9	39.0	
0deg	0.89244	QP	32.8	19.8	-33.9	32.0	-	-13.3	28.6	41.9	
0deg	1.01992	QP	33.4	19.8	-33.8	32.0	-	-12.7	27.4	40.1	
0deg	1.14741	QP	33.5	19.8	-33.8	32.0	-	-12.6	26.4	39.0	
0deg	1.27490	QP	31.9	19.8	-33.8	32.0	-	-14.1	25.4	39.5	

Result = Reading + Ant Factor + Loss (Cable + Attenuator + Filter + D.Factor) - Gain(Ampriifier)

PK with Duty factor

Ant Deg [deg]	Frequency [MHz]	Detector	Reading [dBuV]	Ant Factor [dB/m]	Loss [dB]	Gain [dB]	Duty Factor [dB]	Result [dBuV/m]	Limit [dBuV/m]	Margin [dB]	Remark
0deg	0.12749	PK	77.8	19.9	-74.0	32.1	0.0	-8.4	25.4	33.8	
0deg	0.25498	PK	48.7	19.9	-74.0	32.1	0.0	-37.5	19.4	56.9	
0deg	0.38247	PK	52.9	19.8	-73.9	32.1	0.0	-33.3	15.9	49.2	

Result = Reading + Ant Factor + Loss (Cable + Attenuator + Filter + D.Factor) - Gain(Ampriifier) + Duty factor *

* Since the peak emission result satisfied the average limit, duty factor was omitted.

Result of the fundamental emission at 3m without Distance factor

PK or QP

Ant Deg [deg]	Frequency [MHz]	Detector	Reading [dBuV]	Ant Factor [dB/m]	Loss [dB]	Gain [dB]	Duty Factor [dB]	Result [dBuV/m]	Limit [dBuV/m]	Margin [dB]	Remark
0deg	0.12749	PK	77.8	19.9	6.0	32.1	-	71.6	-	-	Fundamental

Result = Reading + Ant Factor + Loss (Cable+Attenuator+Filter) - Gain(Ampriifier)

* Other frequency noises omitted in this report were not seen or had enough margin (more than 20 dB).

*The test result is rounded off to one or two decimal places, so some differences might be observed.

UL Japan, Inc.

Ise EMC Lab.

4383-326 Asama-cho, Ise-shi, Mie-ken 516-0021 JAPAN

Telephone : +81 596 24 8999

Facsimile : +81 596 24 8124

Radiated Emission below 30 MHz (Fundamental and Spurious Emission)

Report No. 13226969H
Test place Ise EMC Lab.
Semi Anechoic Chamber No.1
Date 04/16/2020
Temperature / Humidity 23 deg. C / 43 % RH
Engineer Junya Okuno
Mode Mode 3 (5 W)

PK or QP

Ant Deg [deg] or Polarity [Hori/Vert]	Frequency [MHz]	Detector	Reading [dBuV]	Ant Factor [dB/m]	Loss [dB]	Gain [dB]	Duty Factor [dB]	Result [dBuV/m]	Limit dBuV/m	Margin [dB]	Remark
0deg	0.12700	PK	76.0	19.9	-74.0	32.1	-	-10.2	45.5	55.7	Fundamental
0deg	0.25400	PK	44.2	19.9	-74.0	32.1	-	-42.0	39.5	81.5	
0deg	0.38100	PK	54.3	19.8	-73.9	32.1	-	-31.9	36.0	67.9	
0deg	0.50800	QP	33.1	19.8	-33.9	32.1	-	-13.1	33.5	46.6	
0deg	0.63500	QP	45.3	19.8	-33.9	32.0	-	-0.8	31.5	32.3	
0deg	0.76200	QP	31.9	19.8	-33.9	32.0	-	-14.2	29.9	44.1	
0deg	0.88900	QP	40.4	19.8	-33.9	32.0	-	-5.7	28.6	34.3	
0deg	1.01600	QP	31.2	19.8	-33.8	32.0	-	-14.9	27.4	42.3	
0deg	1.14300	QP	37.3	19.8	-33.8	32.0	-	-8.8	26.4	35.2	
0deg	1.27000	QP	30.9	19.8	-33.8	32.0	-	-15.1	25.5	40.6	

Result = Reading + Ant Factor + Loss (Cable + Attenuator + Filter + D.Factor) - Gain(Amplifier)

PK with Duty factor

Ant Deg [deg]	Frequency [MHz]	Detector	Reading [dBuV]	Ant Factor [dB/m]	Loss [dB]	Gain [dB]	Duty Factor [dB]	Result [dBuV/m]	Limit dBuV/m	Margin [dB]	Remark
0deg	0.12700	PK	76.0	19.9	-74.0	32.1	0.0	-10.2	25.5	35.7	
0deg	0.25400	PK	44.2	19.9	-74.0	32.1	0.0	-42.0	19.5	61.5	
0deg	0.38100	PK	54.3	19.8	-73.9	32.1	0.0	-31.9	16.0	47.9	

Result = Reading + Ant Factor + Loss (Cable + Attenuator + Filter + D.Factor) - Gain(Amplifier) + Duty factor *

* Since the peak emission result satisfied the average limit, duty factor was omitted.

Result of the fundamental emission at 3m without Distance factor

PK or QP

Ant Deg [deg]	Frequency [MHz]	Detector	Reading [dBuV]	Ant Factor [dB/m]	Loss [dB]	Gain [dB]	Duty Factor [dB]	Result [dBuV/m]	Limit [dBuV/m]	Margin [dB]	Remark
0deg	0.12700	PK	76.0	19.9	6.0	32.1	-	69.8	-	-	Fundamental

Result = Reading + Ant Factor + Loss (Cable+Attenuator+Filter) - Gain(Amplifier)

* Other frequency noises omitted in this report were not seen or had enough margin (more than 20 dB).

*The test result is rounded off to one or two decimal places, so some differences might be observed.

UL Japan, Inc.

Ise EMC Lab.

4383-326 Asama-cho, Ise-shi, Mie-ken 516-0021 JAPAN

Telephone : +81 596 24 8999

Facsimile : +81 596 24 8124

Radiated Emission below 30 MHz (Fundamental and Spurious Emission)

Report No. 13226969H
Test place Ise EMC Lab.
Semi Anechoic Chamber No.2
Date 05/13/2020
Temperature / Humidity 20 deg. C / 40 % RH
Engineer Tomohisa Nakagawa
Mode Mode 4 (10 W)

PK or QP

Ant Deg [deg] or Polarity [Hori/Vert]	Frequency [MHz]	Detector	Reading [dBuV]	Ant Factor [dB/m]	Loss [dB]	Gain [dB]	Duty Factor [dB]	Result [dBuV/m]	Limit [dBuV/m]	Margin [dB]	Remark
0deg	0.12763	PK	88.4	19.9	-74.0	32.1	-	2.3	45.4	43.2	Fundamental
0deg	0.25525	PK	55.3	19.9	-74.0	32.1	-	-30.9	39.4	70.3	
0deg	0.38288	PK	64.1	19.8	-73.9	32.1	-	-22.1	35.9	58.0	
0deg	0.51051	QP	45.9	19.8	-33.9	32.1	-	-0.3	33.4	33.7	
0deg	0.63814	QP	51.2	19.8	-33.9	32.0	-	5.1	31.5	26.4	
0deg	0.76576	QP	41.3	19.8	-33.9	32.0	-	-4.8	29.9	34.7	
0deg	0.89339	QP	46.2	19.8	-33.9	32.0	-	0.1	28.5	28.4	
0deg	1.02102	QP	38.4	19.8	-33.8	32.0	-	-7.7	27.4	35.1	
0deg	1.14863	QP	41.2	19.8	-33.8	32.0	-	-4.9	26.4	31.3	
0deg	1.27627	QP	35.2	19.8	-33.8	32.0	-	-10.8	25.4	36.2	

Result = Reading + Ant Factor + Loss (Cable + Attenuator + Filter + D.Factor) - Gain(Ampriifier)

PK with Duty factor

Ant Deg [deg]	Frequency [MHz]	Detector	Reading [dBuV]	Ant Factor [dB/m]	Loss [dB]	Gain [dB]	Duty Factor [dB]	Result [dBuV/m]	Limit [dBuV/m]	Margin [dB]	Remark
0deg	0.12763	PK	88.4	19.9	-74.0	32.1	0.0	2.3	25.4	23.2	
0deg	0.25525	PK	55.3	19.9	-74.0	32.1	0.0	-30.9	19.4	50.3	
0deg	0.38288	PK	64.1	19.8	-73.9	32.1	0.0	-22.1	15.9	38.0	

Result = Reading + Ant Factor + Loss (Cable + Attenuator + Filter + D.Factor) - Gain(Ampriifier) + Duty factor *

* Since the peak emission result satisfied the average limit, duty factor was omitted.

Result of the fundamental emission at 3m without Distance factor

PK or QP

Ant Deg [deg]	Frequency [MHz]	Detector	Reading [dBuV]	Ant Factor [dB/m]	Loss [dB]	Gain [dB]	Duty Factor [dB]	Result [dBuV/m]	Limit [dBuV/m]	Margin [dB]	Remark
0deg	0.12763	PK	88.4	19.9	6.0	32.1	-	82.3	-	-	Fundamental

Result = Reading + Ant Factor + Loss (Cable+Attenuator+Filter) - Gain(Ampriifier)

* Other frequency noises omitted in this report were not seen or had enough margin (more than 20 dB).

*The test result is rounded off to one or two decimal places, so some differences might be observed.

UL Japan, Inc.

Ise EMC Lab.

4383-326 Asama-cho, Ise-shi, Mie-ken 516-0021 JAPAN

Telephone : +81 596 24 8999

Facsimile : +81 596 24 8124

Radiated Emission below 30 MHz (Fundamental and Spurious Emission)

Report No. 13226969H
Test place Ise EMC Lab.
Semi Anechoic Chamber No.2
Date 05/13/2020
Temperature / Humidity 20 deg. C / 40 % RH
Engineer Tomohisa Nakagawa
Mode Mode 5 (10 W)

PK or QP

Ant Deg [deg] or Polarity [Hori/Vert]	Frequency [MHz]	Detector	Reading [dBuV]	Ant Factor [dB/m]	Loss [dB]	Gain [dB]	Duty Factor [dB]	Result [dBuV/m]	Limit [dBuV/m]	Margin [dB]	Remark
0deg	0.12776	PK	88.8	19.9	-74.0	32.1	-	2.6	45.4	42.8	Fundamental
0deg	0.25551	PK	55.4	19.9	-74.0	32.1	-	-30.8	39.4	70.2	
0deg	0.38327	PK	65.3	19.8	-73.9	32.1	-	-20.9	35.9	56.8	
0deg	0.51102	QP	46.2	19.8	-33.9	32.1	-	0.0	33.4	33.4	
0deg	0.63878	QP	53.3	19.8	-33.9	32.0	-	7.2	31.5	24.3	
0deg	0.76654	QP	41.8	19.8	-33.9	32.0	-	-4.3	29.9	34.2	
0deg	0.89429	QP	46.1	19.8	-33.9	32.0	-	0.0	28.5	28.5	
0deg	1.02205	QP	38.4	19.8	-33.8	32.0	-	-7.7	27.4	35.1	
0deg	1.14804	QP	42.0	19.8	-33.8	32.0	-	-4.1	26.4	30.5	
0deg	1.27756	QP	35.5	19.8	-33.8	32.0	-	-10.5	25.4	35.9	

Result = Reading + Ant Factor + Loss (Cable + Attenuator + Filter + D.Factor) - Gain(Amplifier)

PK with Duty factor

Ant Deg [deg]	Frequency [MHz]	Detector	Reading [dBuV]	Ant Factor [dB/m]	Loss [dB]	Gain [dB]	Duty Factor [dB]	Result [dBuV/m]	Limit [dBuV/m]	Margin [dB]	Remark
0deg	0.12776	PK	88.8	19.9	-74.0	32.1	0.0	2.6	25.4	22.8	
0deg	0.25551	PK	55.4	19.9	-74.0	32.1	0.0	-30.8	19.4	50.2	
0deg	0.38327	PK	65.3	19.8	-73.9	32.1	0.0	-20.9	15.9	36.8	

Result = Reading + Ant Factor + Loss (Cable + Attenuator + Filter + D.Factor) - Gain(Amplifier) + Duty factor *

* Since the peak emission result satisfied the average limit, duty factor was omitted.

Result of the fundamental emission at 3m without Distance factor

PK or QP

Ant Deg [deg]	Frequency [MHz]	Detector	Reading [dBuV]	Ant Factor [dB/m]	Loss [dB]	Gain [dB]	Duty Factor [dB]	Result [dBuV/m]	Limit [dBuV/m]	Margin [dB]	Remark
0deg	0.12776	PK	88.8	19.9	6.0	32.1	-	82.6	-	-	Fundamental

Result = Reading + Ant Factor + Loss (Cable+Attenuator+Filter) - Gain(Amplifier)

* Other frequency noises omitted in this report were not seen or had enough margin (more than 20 dB).

*The test result is rounded off to one or two decimal places, so some differences might be observed.

UL Japan, Inc.

Ise EMC Lab.

4383-326 Asama-cho, Ise-shi, Mie-ken 516-0021 JAPAN

Telephone : +81 596 24 8999

Facsimile : +81 596 24 8124

Radiated Emission below 30 MHz (Fundamental and Spurious Emission)

Report No. 13226969H
Test place Ise EMC Lab.
Semi Anechoic Chamber No.2
Date 05/13/2020
Temperature / Humidity 20 deg. C / 40 % RH
Engineer Tomohisa Nakagawa
Mode Mode 6 (10 W)

PK or QP

Ant Deg [deg] or Polarity [Hori/Vert]	Frequency [MHz]	Detector	Reading [dBuV]	Ant Factor [dB/m]	Loss [dB]	Gain [dB]	Duty Factor [dB]	Result [dBuV/m]	Limit [dBuV/m]	Margin [dB]	Remark
0deg	0.12802	PK	89.4	19.9	-74.0	32.1	-	3.3	45.4	42.2	Fundamental
0deg	0.25603	PK	55.5	19.9	-74.0	32.1	-	-30.7	39.4	70.1	
0deg	0.38405	PK	65.5	19.8	-73.9	32.1	-	-20.7	35.9	56.6	
0deg	0.51206	QP	46.2	19.8	-33.9	32.1	-	0.0	33.4	33.4	
0deg	0.64008	QP	53.3	19.8	-33.9	32.0	-	7.2	31.5	24.3	
0deg	0.76810	QP	41.8	19.8	-33.9	32.0	-	-4.3	29.9	34.2	
0deg	0.89611	QP	46.1	19.8	-33.9	32.0	-	0.0	28.5	28.5	
0deg	1.02413	QP	38.4	19.8	-33.8	32.0	-	-7.7	27.4	35.1	
0deg	1.15214	QP	42.1	19.8	-33.8	32.0	-	-4.0	26.3	30.3	
0deg	1.28016	QP	35.5	19.8	-33.8	32.0	-	-10.5	25.4	35.9	

Result = Reading + Ant Factor + Loss (Cable + Attenuator + Filter + D.Factor) - Gain(Amplifier)

PK with Duty factor

Ant Deg [deg]	Frequency [MHz]	Detector	Reading [dBuV]	Ant Factor [dB/m]	Loss [dB]	Gain [dB]	Duty Factor [dB]	Result [dBuV/m]	Limit [dBuV/m]	Margin [dB]	Remark
0deg	0.12802	PK	89.4	19.9	-74.0	32.1	0.0	3.3	25.4	22.2	
0deg	0.25603	PK	55.5	19.9	-74.0	32.1	0.0	-30.7	19.4	50.1	
0deg	0.38405	PK	65.5	19.8	-73.9	32.1	0.0	-20.7	15.9	36.6	

Result = Reading + Ant Factor + Loss (Cable + Attenuator + Filter + D.Factor) - Gain(Amplifier) + Duty factor *

* Since the peak emission result satisfied the average limit, duty factor was omitted.

Result of the fundamental emission at 3m without Distance factor

PK or QP

Ant Deg [deg]	Frequency [MHz]	Detector	Reading [dBuV]	Ant Factor [dB/m]	Loss [dB]	Gain [dB]	Duty Factor [dB]	Result [dBuV/m]	Limit [dBuV/m]	Margin [dB]	Remark
0deg	0.12802	PK	89.4	19.9	6.0	32.1	-	83.3	-	-	Fundamental

Result = Reading + Ant Factor + Loss (Cable+Attenuator+Filter) - Gain(Amplifier)

* Other frequency noises omitted in this report were not seen or had enough margin (more than 20 dB).

*The test result is rounded off to one or two decimal places, so some differences might be observed.

UL Japan, Inc.

Ise EMC Lab.

4383-326 Asama-cho, Ise-shi, Mie-ken 516-0021 JAPAN

Telephone : +81 596 24 8999

Facsimile : +81 596 24 8124

Radiated Emission below 30 MHz (Fundamental and Spurious Emission)

Report No. 13226969H
Test place Ise EMC Lab.
Semi Anechoic Chamber No.2
Date 05/13/2020
Temperature / Humidity 20 deg. C / 40 % RH
Engineer Tomohisa Nakagawa
Mode Mode 7 (10 W)

PK or QP

Ant Deg [deg] or Polarity [Hori/Vert]	Frequency [MHz]	Detector	Reading [dBuV]	Ant Factor [dB/m]	Loss [dB]	Gain [dB]	Duty Factor [dB]	Result [dBuV/m]	Limit [dBuV/m]	Margin [dB]	Remark
0deg	0.12855	PK	88.5	19.9	-74.0	32.1	-	2.3	45.4	43.1	Fundamental
0deg	0.25710	PK	55.5	19.9	-74.0	32.1	-	-30.7	39.4	70.1	
0deg	0.38565	PK	64.0	19.8	-73.9	32.1	-	-22.2	35.9	58.1	
0deg	0.51420	QP	46.1	19.8	-33.9	32.1	-	-0.1	33.4	33.5	
0deg	0.64275	QP	51.2	19.8	-33.9	32.0	-	5.1	31.4	26.3	
0deg	0.77129	QP	41.4	19.8	-33.9	32.0	-	-4.7	29.8	34.5	
0deg	0.89984	QP	42.7	19.8	-33.9	32.0	-	-3.4	28.5	31.9	
0deg	1.02840	QP	38.1	19.8	-33.8	32.0	-	-8.0	27.3	35.3	
0deg	1.15694	QP	40.1	19.8	-33.8	32.0	-	-6.0	26.3	32.3	
0deg	1.28549	QP	34.9	19.8	-33.8	32.0	-	-11.1	25.4	36.5	

Result = Reading + Ant Factor + Loss (Cable + Attenuator + Filter + D.Factor) - Gain(Ampriifier)

PK with Duty factor

Ant Deg [deg]	Frequency [MHz]	Detector	Reading [dBuV]	Ant Factor [dB/m]	Loss [dB]	Gain [dB]	Duty Factor [dB]	Result [dBuV/m]	Limit [dBuV/m]	Margin [dB]	Remark
0deg	0.12855	PK	88.5	19.9	-74.0	32.1	0.0	2.3	25.4	23.1	
0deg	0.25710	PK	55.5	19.9	-74.0	32.1	0.0	-30.7	19.4	50.1	
0deg	0.38565	PK	64.0	19.8	-73.9	32.1	0.0	-22.2	15.9	38.1	

Result = Reading + Ant Factor + Loss (Cable + Attenuator + Filter + D.Factor) - Gain(Ampriifier) + Duty factor *

* Since the peak emission result satisfied the average limit, duty factor was omitted.

Result of the fundamental emission at 3m without Distance factor

PK or QP

Ant Deg [deg]	Frequency [MHz]	Detector	Reading [dBuV]	Ant Factor [dB/m]	Loss [dB]	Gain [dB]	Duty Factor [dB]	Result [dBuV/m]	Limit [dBuV/m]	Margin [dB]	Remark
0deg	0.12855	PK	88.5	19.9	6.0	32.1	-	82.3	-	-	Fundamental

Result = Reading + Ant Factor + Loss (Cable+Attenuator+Filter) - Gain(Ampriifier)

* Other frequency noises omitted in this report were not seen or had enough margin (more than 20 dB).

*The test result is rounded off to one or two decimal places, so some differences might be observed.

UL Japan, Inc.

Ise EMC Lab.

4383-326 Asama-cho, Ise-shi, Mie-ken 516-0021 JAPAN

Telephone : +81 596 24 8999

Facsimile : +81 596 24 8124

Radiated Emission below 30 MHz (Fundamental and Spurious Emission)

Report No. 13226969H
Test place Ise EMC Lab.
Semi Anechoic Chamber No.2
Date 05/13/2020
Temperature / Humidity 20 deg. C / 40 % RH
Engineer Tomohisa Nakagawa
Mode Mode 8 (10 W)

PK or QP

Ant Deg [deg] or Polarity [Hori/Vert]	Frequency [MHz]	Detector	Reading [dBuV]	Ant Factor [dB/m]	Loss [dB]	Gain [dB]	Duty Factor [dB]	Result [dBuV/m]	Limit [dBuV/m]	Margin [dB]	Remark
0deg	0.12737	PK	88.6	19.9	-74.0	32.1	-	2.4	45.4	43.0	Fundamental
0deg	0.25475	PK	56.0	19.9	-74.0	32.1	-	-30.2	39.4	69.6	
0deg	0.38212	PK	64.2	19.8	-73.9	32.1	-	-22.0	35.9	57.9	
0deg	0.50949	QP	46.0	19.8	-33.9	32.1	-	-0.2	33.5	33.7	
0deg	0.63687	QP	51.4	19.8	-33.9	32.0	-	5.3	31.5	26.2	
0deg	0.76424	QP	41.4	19.8	-33.9	32.0	-	-4.7	29.9	34.6	
0deg	0.89161	QP	42.7	19.8	-33.9	32.0	-	-3.4	28.6	32.0	
0deg	1.01898	QP	38.2	19.8	-33.8	32.0	-	-7.9	27.4	35.3	
0deg	1.14636	QP	40.2	19.8	-33.8	32.0	-	-5.9	26.4	32.3	
0deg	1.27373	QP	34.8	19.8	-33.8	32.0	-	-11.2	25.4	36.6	

Result = Reading + Ant Factor + Loss (Cable + Attenuator + Filter + D.Factor) - Gain(Amplifier)

PK with Duty factor

Ant Deg [deg]	Frequency [MHz]	Detector	Reading [dBuV]	Ant Factor [dB/m]	Loss [dB]	Gain [dB]	Duty Factor [dB]	Result [dBuV/m]	Limit [dBuV/m]	Margin [dB]	Remark
0deg	0.12737	PK	88.6	19.9	-74.0	32.1	0.0	2.4	25.4	23.0	
0deg	0.25475	PK	56.0	19.9	-74.0	32.1	0.0	-30.2	19.4	49.6	
0deg	0.38212	PK	64.2	19.8	-73.9	32.1	0.0	-22.0	15.9	37.9	

Result = Reading + Ant Factor + Loss (Cable + Attenuator + Filter + D.Factor) - Gain(Amplifier) + Duty factor *

* Since the peak emission result satisfied the average limit, duty factor was omitted.

Result of the fundamental emission at 3m without Distance factor

PK or QP

Ant Deg [deg]	Frequency [MHz]	Detector	Reading [dBuV]	Ant Factor [dB/m]	Loss [dB]	Gain [dB]	Duty Factor [dB]	Result [dBuV/m]	Limit [dBuV/m]	Margin [dB]	Remark
0deg	0.12737	PK	88.6	19.9	6.0	32.1	-	82.4	-	-	Fundamental

Result = Reading + Ant Factor + Loss (Cable+Attenuator+Filter) - Gain(Amplifier)

* Other frequency noises omitted in this report were not seen or had enough margin (more than 20 dB).

*The test result is rounded off to one or two decimal places, so some differences might be observed.

UL Japan, Inc.

Ise EMC Lab.

4383-326 Asama-cho, Ise-shi, Mie-ken 516-0021 JAPAN

Telephone : +81 596 24 8999

Facsimile : +81 596 24 8124

Radiated Emission below 30 MHz (Fundamental and Spurious Emission)

Report No. 13226969H
Test place Ise EMC Lab.
Semi Anechoic Chamber No.2
Date 05/13/2020
Temperature / Humidity 20 deg. C / 40 % RH
Engineer Tomohisa Nakagawa
Mode Mode 9 (10 W)

PK or QP

Ant Deg [deg] or Polarity [Hori/Vert]	Frequency [MHz]	Detector	Reading [dBuV]	Ant Factor [dB/m]	Loss [dB]	Gain [dB]	Duty Factor [dB]	Result [dBuV/m]	Limit [dBuV/m]	Margin [dB]	Remark
0deg	0.12725	PK	88.7	19.9	-74.0	32.1	-	2.6	45.4	42.9	Fundamental
0deg	0.25450	PK	55.8	19.9	-74.0	32.1	-	-30.4	39.5	69.9	
0deg	0.38174	PK	64.3	19.8	-73.9	32.1	-	-21.9	36.0	57.9	
0deg	0.50899	QP	46.1	19.8	-33.9	32.1	-	-0.1	33.5	33.6	
0deg	0.63624	QP	51.5	19.8	-33.9	32.0	-	5.4	31.5	26.1	
0deg	0.76349	QP	41.4	19.8	-33.9	32.0	-	-4.7	29.9	34.6	
0deg	0.89074	QP	43.0	19.8	-33.9	32.0	-	-3.1	28.6	31.7	
0deg	1.10798	QP	38.6	19.8	-33.8	32.0	-	-7.5	26.7	34.2	
0deg	1.12523	QP	39.4	19.8	-33.8	32.0	-	-6.7	26.5	33.2	
0deg	1.27248	QP	34.4	19.8	-33.8	32.0	-	-11.6	25.5	37.1	

Result = Reading + Ant Factor + Loss (Cable + Attenuator + Filter + D.Factor) - Gain(Ampriifier)

PK with Duty factor

Ant Deg [deg]	Frequency [MHz]	Detector	Reading [dBuV]	Ant Factor [dB/m]	Loss [dB]	Gain [dB]	Duty Factor [dB]	Result [dBuV/m]	Limit [dBuV/m]	Margin [dB]	Remark
0deg	0.12725	PK	88.7	19.9	-74.0	32.1	0.0	2.6	25.4	22.9	
0deg	0.25450	PK	55.8	19.9	-74.0	32.1	0.0	-30.4	19.5	49.9	
0deg	0.38174	PK	64.3	19.8	-73.9	32.1	0.0	-21.9	16.0	37.9	

Result = Reading + Ant Factor + Loss (Cable + Attenuator + Filter + D.Factor) - Gain(Ampriifier) + Duty factor *

* Since the peak emission result satisfied the average limit, duty factor was omitted.

Result of the fundamental emission at 3m without Distance factor

PK or QP

Ant Deg [deg]	Frequency [MHz]	Detector	Reading [dBuV]	Ant Factor [dB/m]	Loss [dB]	Gain [dB]	Duty Factor [dB]	Result [dBuV/m]	Limit [dBuV/m]	Margin [dB]	Remark
0deg	0.12725	PK	88.7	19.9	6.0	32.1	-	82.6	-	-	Fundamental

Result = Reading + Ant Factor + Loss (Cable+Attenuator+Filter) - Gain(Ampriifier)

* Other frequency noises omitted in this report were not seen or had enough margin (more than 20 dB).

*The test result is rounded off to one or two decimal places, so some differences might be observed.

UL Japan, Inc.

Ise EMC Lab.

4383-326 Asama-cho, Ise-shi, Mie-ken 516-0021 JAPAN

Telephone : +81 596 24 8999

Facsimile : +81 596 24 8124

Radiated Emission below 30 MHz (Fundamental and Spurious Emission)

Report No. 13226969H
Test place Ise EMC Lab.
Semi Anechoic Chamber No.2
Date 05/13/2020
Temperature / Humidity 20 deg. C / 40 % RH
Engineer Tomohisa Nakagawa
Mode Mode 10 (10 W)

PK or QP

Ant Deg [deg] or Polarity [Hori/Vert]	Frequency [MHz]	Detector	Reading [dBuV]	Ant Factor [dB/m]	Loss [dB]	Gain [dB]	Duty Factor [dB]	Result [dBuV/m]	Limit [dBuV/m]	Margin [dB]	Remark
0deg	0.12699	PK	88.8	19.9	-74.0	32.1	-	2.6	45.5	42.9	Fundamental
0deg	0.25400	PK	55.7	19.9	-74.0	32.1	-	-30.5	39.5	70.0	
0deg	0.38100	PK	64.2	19.8	-73.9	32.1	-	-22.0	36.0	58.0	
0deg	0.50800	QP	46.2	19.8	-33.9	32.1	-	0.0	33.5	33.5	
0deg	0.63500	QP	51.5	19.8	-33.9	32.0	-	5.4	31.5	26.1	
0deg	0.76199	QP	41.4	19.8	-33.9	32.0	-	-4.7	29.9	34.6	
0deg	0.88899	QP	43.1	19.8	-33.9	32.0	-	-3.0	28.6	31.6	
0deg	1.01599	QP	38.5	19.8	-33.8	32.0	-	-7.6	27.4	35.0	
0deg	1.14299	QP	39.3	19.8	-33.8	32.0	-	-6.8	26.4	33.2	
0deg	1.26999	QP	34.4	19.8	-33.8	32.0	-	-11.6	25.5	37.1	

Result = Reading + Ant Factor + Loss (Cable + Attenuator + Filter + D.Factor) - Gain(Ampriifier)

PK with Duty factor

Ant Deg [deg]	Frequency [MHz]	Detector	Reading [dBuV]	Ant Factor [dB/m]	Loss [dB]	Gain [dB]	Duty Factor [dB]	Result [dBuV/m]	Limit [dBuV/m]	Margin [dB]	Remark
0deg	0.12699	PK	88.8	19.9	-74.0	32.1	0.0	2.6	25.5	22.9	
0deg	0.25400	PK	55.7	19.9	-74.0	32.1	0.0	-30.5	19.5	50.0	
0deg	0.38100	PK	64.2	19.8	-73.9	32.1	0.0	-22.0	16.0	38.0	

Result = Reading + Ant Factor + Loss (Cable + Attenuator + Filter + D.Factor) - Gain(Ampriifier) + Duty factor *

* Since the peak emission result satisfied the average limit, duty factor was omitted.

Result of the fundamental emission at 3m without Distance factor

PK or QP

Ant Deg [deg]	Frequency [MHz]	Detector	Reading [dBuV]	Ant Factor [dB/m]	Loss [dB]	Gain [dB]	Duty Factor [dB]	Result [dBuV/m]	Limit [dBuV/m]	Margin [dB]	Remark
0deg	0.12699	PK	88.8	19.9	6.0	32.1	-	82.6	-	-	Fundamental

Result = Reading + Ant Factor + Loss (Cable+Attenuator+Filter) - Gain(Ampriifier)

* Other frequency noises omitted in this report were not seen or had enough margin (more than 20 dB).

*The test result is rounded off to one or two decimal places, so some differences might be observed.

UL Japan, Inc.

Ise EMC Lab.

4383-326 Asama-cho, Ise-shi, Mie-ken 516-0021 JAPAN

Telephone : +81 596 24 8999

Facsimile : +81 596 24 8124

Radiated Emission below 30 MHz (Fundamental and Spurious Emission)

Report No. 13226969H
Test place Ise EMC Lab.
Semi Anechoic Chamber No.2
Date 05/13/2020
Temperature / Humidity 20 deg. C / 40 % RH
Engineer Tomohisa Nakagawa
Mode Mode 11 (10 W)

PK or QP

Ant Deg [deg] or Polarity [Hori/Vert]	Frequency [MHz]	Detector	Reading [dBuV]	Ant Factor [dB/m]	Loss [dB]	Gain [dB]	Duty Factor [dB]	Result [dBuV/m]	Limit [dBuV/m]	Margin [dB]	Remark
0deg	0.12652	PK	88.8	19.9	-74.0	32.1	-	2.6	45.5	42.9	Fundamental
0deg	0.25303	PK	55.9	19.9	-74.0	32.1	-	-30.3	39.5	69.8	
0deg	0.37955	PK	64.2	19.9	-73.9	32.1	-	-22.0	36.0	58.0	
0deg	0.50606	QP	46.1	19.8	-33.9	32.1	-	-0.1	33.5	33.6	
0deg	0.63258	QP	51.3	19.8	-33.9	32.0	-	5.2	31.6	26.5	
0deg	0.75909	QP	41.5	19.8	-33.9	32.0	-	-4.6	30.0	34.6	
0deg	0.88561	QP	42.6	19.8	-33.9	32.0	-	-3.5	28.6	32.1	
0deg	1.01212	QP	38.2	19.8	-33.8	32.0	-	-7.9	27.5	35.4	
0deg	1.13864	QP	40.2	19.8	-33.8	32.0	-	-5.9	26.4	32.3	
0deg	1.26515	QP	34.8	19.8	-33.8	32.0	-	-11.2	25.5	36.7	

Result = Reading + Ant Factor + Loss (Cable + Attenuator + Filter + D.Factor) - Gain(Ampriifier)

PK with Duty factor

Ant Deg [deg]	Frequency [MHz]	Detector	Reading [dBuV]	Ant Factor [dB/m]	Loss [dB]	Gain [dB]	Duty Factor [dB]	Result [dBuV/m]	Limit [dBuV/m]	Margin [dB]	Remark
0deg	0.12652	PK	88.8	19.9	-74.0	32.1	0.0	2.6	25.5	22.9	
0deg	0.25303	PK	55.9	19.9	-74.0	32.1	0.0	-30.3	19.5	49.8	
0deg	0.37955	PK	64.2	19.9	-73.9	32.1	0.0	-22.0	16.0	38.0	

Result = Reading + Ant Factor + Loss (Cable + Attenuator + Filter + D.Factor) - Gain(Ampriifier) + Duty factor *

* Since the peak emission result satisfied the average limit, duty factor was omitted.

Result of the fundamental emission at 3m without Distance factor

PK or QP

Ant Deg [deg]	Frequency [MHz]	Detector	Reading [dBuV]	Ant Factor [dB/m]	Loss [dB]	Gain [dB]	Duty Factor [dB]	Result [dBuV/m]	Limit [dBuV/m]	Margin [dB]	Remark
0deg	0.12652	PK	88.8	19.9	6.0	32.1	-	82.6	-	-	Fundamental

Result = Reading + Ant Factor + Loss (Cable+Attenuator+Filter) - Gain(Ampriifier)

* Other frequency noises omitted in this report were not seen or had enough margin (more than 20 dB).

*The test result is rounded off to one or two decimal places, so some differences might be observed.

UL Japan, Inc.

Ise EMC Lab.

4383-326 Asama-cho, Ise-shi, Mie-ken 516-0021 JAPAN

Telephone : +81 596 24 8999

Facsimile : +81 596 24 8124

Radiated Emission above 30 MHz (Spurious Emission)

Report No. 13226969H
Test place Ise EMC Lab.
Semi Anechoic Chamber No.1
Date 04/01/2020
Temperature / Humidity 21 deg. C / 52 % RH
Engineer Takeshi Hiyaji
Mode Mode 1 (5 W)

Polarity	Frequency [MHz]	Detector	Reading [dBuV]	Ant.Fac. [dB/m]	Loss [dB]	Gain [dB]	Result [dBuV/m]	Limit [dBuV/m]	Margin [dB]	Remark
Hori.	46.954	QP	28.5	12.2	7.7	38.8	9.6	40.0	30.4	
Hori.	68.267	QP	28.4	6.5	8.1	38.9	4.2	40.0	35.8	
Hori.	97.384	QP	28.3	9.6	8.6	38.9	7.5	43.5	36.0	
Hori.	120.739	QP	28.4	12.8	8.9	39.0	11.2	43.5	32.4	
Hori.	195.348	QP	28.5	16.4	9.7	38.9	15.7	43.5	27.8	
Hori.	203.619	QP	38.1	11.3	9.8	38.9	20.3	43.5	23.2	
Vert.	46.892	QP	43.4	12.2	7.7	38.8	24.5	40.0	15.5	
Vert.	68.814	QP	49.6	6.5	8.1	38.9	25.3	40.0	14.7	
Vert.	94.523	QP	35.4	9.2	8.5	38.9	14.1	43.5	29.4	
Vert.	116.232	QP	34.0	12.4	8.8	39.0	16.2	43.5	27.3	
Vert.	184.780	QP	32.9	16.2	9.6	38.9	19.8	43.5	23.7	
Vert.	202.944	QP	40.5	11.3	9.8	38.9	22.7	43.5	20.8	

Result = Reading + Ant Factor + Loss (Cable+Attenuator) - Gain(Amplifier)

*Other frequency noises omitted in this report were not seen or had enough margin (more than 20 dB).

*The test result is rounded off to one or two decimal places, so some differences might be observed.

UL Japan, Inc.

Ise EMC Lab.

4383-326 Asama-cho, Ise-shi, Mie-ken 516-0021 JAPAN

Telephone : +81 596 24 8999

Facsimile : +81 596 24 8124

Radiated Emission above 30 MHz (Spurious Emission)

Report No. 13226969H
Test place Ise EMC Lab.
Semi Anechoic Chamber No.1
Date 04/01/2020
Temperature / Humidity 21 deg. C / 52 % RH
Engineer Takeshi Hiyaji
Mode Mode 2 (10 W)

Polarity	Frequency [MHz]	Detector	Reading [dBuV]	Ant.Fac. [dB/m]	Loss [dB]	Gain [dB]	Result [dBuV/m]	Limit [dBuV/m]	Margin [dB]	Remark
Hori.	34.710	QP	28.8	16.6	7.5	38.8	14.1	40.0	25.9	
Hori.	68.387	QP	28.9	6.5	8.1	38.9	4.7	40.0	35.4	
Hori.	120.137	QP	28.4	12.8	8.9	39.0	11.1	43.5	32.4	
Hori.	161.887	QP	28.3	15.4	9.4	38.9	14.1	43.5	29.4	
Hori.	201.819	QP	40.1	11.4	9.8	38.9	22.3	43.5	21.2	
Hori.	589.715	QP	28.5	19.0	12.8	38.2	22.1	46.0	23.9	
Vert.	47.200	QP	44.5	12.1	7.7	38.8	25.5	40.0	14.5	
Vert.	68.067	QP	46.4	6.5	8.1	38.9	22.2	40.0	17.8	
Vert.	114.415	QP	31.1	12.1	8.8	39.0	13.1	43.5	30.5	
Vert.	184.391	QP	30.7	16.2	9.6	38.9	17.6	43.5	26.0	
Vert.	201.122	QP	30.3	11.4	9.8	38.9	12.5	43.5	31.0	
Vert.	588.764	QP	29.4	19.0	12.8	38.2	23.0	46.0	23.0	

Result = Reading + Ant Factor + Loss (Cable+Attenuator) - Gain(Amplifier)

*Other frequency noises omitted in this report were not seen or had enough margin (more than 20 dB).

*The test result is rounded off to one or two decimal places, so some differences might be observed.

UL Japan, Inc.

Ise EMC Lab.

4383-326 Asama-cho, Ise-shi, Mie-ken 516-0021 JAPAN

Telephone : +81 596 24 8999

Facsimile : +81 596 24 8124

Radiated Emission above 30 MHz (Spurious Emission)

Report No. 13226969H
Test place Ise EMC Lab.
Semi Anechoic Chamber No.3
Date 05/17/2020
Temperature / Humidity 22 deg. C / 49 % RH
Engineer Junki Nagatomi
Mode Mode 3 (5 W)

Polarity	Frequency [MHz]	Detector	Reading [dBuV]	Ant.Fac. [dB/m]	Loss [dB]	Gain [dB]	Result [dBuV/m]	Limit [dBuV/m]	Margin [dB]	Remark
Hori.	43.553	QP	23.6	13.5	7.3	32.2	12.2	40.0	27.8	
Hori.	59.173	QP	23.1	8.1	7.5	32.2	6.6	40.0	33.4	
Hori.	72.378	QP	23.8	6.3	7.7	32.2	5.7	40.0	34.3	
Hori.	172.819	QP	24.5	15.9	8.9	32.1	17.3	43.5	26.3	
Hori.	208.984	QP	25.4	11.2	9.2	32.0	13.8	43.5	29.7	
Hori.	487.796	QP	24.1	17.5	11.2	32.0	20.9	46.0	25.1	
Vert.	43.553	QP	28.8	13.5	7.3	32.2	17.4	40.0	22.6	
Vert.	59.173	QP	33.9	8.1	7.5	32.2	17.4	40.0	22.6	
Vert.	72.378	QP	34.5	6.3	7.7	32.2	16.4	40.0	23.6	
Vert.	172.819	QP	26.0	15.9	8.9	32.1	18.8	43.5	24.8	
Vert.	208.984	QP	23.3	11.2	9.2	32.0	11.7	43.5	31.8	
Vert.	487.796	QP	23.8	17.5	11.2	32.0	20.6	46.0	25.4	

Result = Reading + Ant Factor + Loss (Cable+Attenuator) - Gain(Amplifier)

*Other frequency noises omitted in this report were not seen or had enough margin (more than 20 dB).

*The test result is rounded off to one or two decimal places, so some differences might be observed.

UL Japan, Inc.

Ise EMC Lab.

4383-326 Asama-cho, Ise-shi, Mie-ken 516-0021 JAPAN

Telephone : +81 596 24 8999

Facsimile : +81 596 24 8124

Radiated Emission above 30 MHz (Spurious Emission)

Report No. 13226969H
Test place Ise EMC Lab.
Semi Anechoic Chamber No.2
Date 05/14/2020
Temperature / Humidity 23 deg. C / 44 % RH
Engineer Ken Fujita
Mode Mode 4 (10 W)

Polarity	Frequency [MHz]	Detector	Reading [dBuV]	Ant.Fac. [dB/m]	Loss [dB]	Gain [dB]	Result [dBuV/m]	Limit [dBuV/m]	Margin [dB]	Remark
Hori.	80.112	QP	31.3	6.8	7.8	30.3	15.6	40.0	24.4	
Hori.	109.710	QP	26.8	11.7	8.1	30.2	16.5	43.5	27.0	
Hori.	181.036	QP	27.1	16.2	8.8	29.7	22.4	43.5	21.1	
Hori.	287.972	QP	25.3	13.3	9.7	29.2	19.1	46.0	26.9	
Hori.	425.920	QP	24.1	16.0	10.7	29.8	21.0	46.0	25.0	
Hori.	724.998	QP	22.0	20.0	12.1	29.3	24.9	46.0	21.1	
Vert.	80.112	QP	30.8	6.8	7.8	30.3	15.1	40.0	24.9	
Vert.	109.710	QP	27.4	11.7	8.1	30.2	17.1	43.5	26.4	
Vert.	181.036	QP	25.5	16.2	8.8	29.7	20.8	43.5	22.7	
Vert.	287.972	QP	26.9	13.3	9.7	29.2	20.7	46.0	25.3	
Vert.	425.920	QP	24.0	16.0	10.7	29.8	20.9	46.0	25.1	
Vert.	724.998	QP	22.0	20.0	12.1	29.3	24.9	46.0	21.1	

Result = Reading + Ant Factor + Loss (Cable+Attenuator) - Gain(Amplifier)

*Other frequency noises omitted in this report were not seen or had enough margin (more than 20 dB).

*The test result is rounded off to one or two decimal places, so some differences might be observed.

UL Japan, Inc.

Ise EMC Lab.

4383-326 Asama-cho, Ise-shi, Mie-ken 516-0021 JAPAN

Telephone : +81 596 24 8999

Facsimile : +81 596 24 8124

Radiated Emission above 30 MHz (Spurious Emission)

Report No. 13226969H
Test place Ise EMC Lab.
Semi Anechoic Chamber No.2
Date 05/14/2020
Temperature / Humidity 23 deg. C / 44 % RH
Engineer Ken Fujita
Mode Mode 5 (10 W)

Polarity	Frequency [MHz]	Detector	Reading [dBuV]	Ant.Fac. [dB/m]	Loss [dB]	Gain [dB]	Result [dBuV/m]	Limit [dBuV/m]	Margin [dB]	Remark
Hori.	80.216	QP	33.6	6.8	7.8	30.3	17.9	40.0	22.1	
Hori.	109.812	QP	26.5	11.8	8.1	30.2	16.2	43.5	27.3	
Hori.	180.993	QP	26.1	16.2	8.8	29.7	21.4	43.5	22.1	
Hori.	285.710	QP	30.9	13.3	9.7	29.2	24.7	46.0	21.3	
Hori.	432.236	QP	24.2	16.1	10.7	29.8	21.2	46.0	24.9	
Hori.	721.182	QP	22.0	20.0	12.1	29.3	24.9	46.0	21.2	
Vert.	80.216	QP	38.6	6.8	7.8	30.3	22.9	40.0	17.1	
Vert.	109.812	QP	27.3	11.8	8.1	30.2	17.0	43.5	26.5	
Vert.	180.993	QP	25.6	16.2	8.8	29.7	20.9	43.5	22.6	
Vert.	285.710	QP	26.5	13.3	9.7	29.2	20.3	46.0	25.7	
Vert.	432.236	QP	24.9	16.1	10.7	29.8	21.9	46.0	24.2	
Vert.	721.182	QP	22.0	20.0	12.1	29.3	24.9	46.0	21.2	

Result = Reading + Ant Factor + Loss (Cable+Attenuator) - Gain(Amplifier)

*Other frequency noises omitted in this report were not seen or had enough margin (more than 20 dB).

*The test result is rounded off to one or two decimal places, so some differences might be observed.

UL Japan, Inc.

Ise EMC Lab.

4383-326 Asama-cho, Ise-shi, Mie-ken 516-0021 JAPAN

Telephone : +81 596 24 8999

Facsimile : +81 596 24 8124

Radiated Emission above 30 MHz (Spurious Emission)

Report No. 13226969H
Test place Ise EMC Lab.
Semi Anechoic Chamber No.2
Date 05/14/2020
Temperature / Humidity 23 deg. C / 44 % RH
Engineer Ken Fujita
Mode Mode 6 (10 W)

Polarity	Frequency [MHz]	Detector	Reading [dBuV]	Ant.Fac. [dB/m]	Loss [dB]	Gain [dB]	Result [dBuV/m]	Limit [dBuV/m]	Margin [dB]	Remark
Hori.	80.121	QP	31.7	6.8	7.8	30.3	16.0	40.0	24.0	
Hori.	109.630	QP	26.3	11.7	8.1	30.2	16.0	43.5	27.5	
Hori.	181.723	QP	26.4	16.2	8.8	29.7	21.7	43.5	21.8	
Hori.	286.775	QP	26.9	13.3	9.7	29.2	20.7	46.0	25.3	
Hori.	432.295	QP	26.8	16.1	10.7	29.8	23.8	46.0	22.2	
Hori.	721.001	QP	22.0	20.0	12.1	29.3	24.9	46.0	21.2	
Vert.	80.121	QP	35.7	6.8	7.8	30.3	20.0	40.0	20.0	
Vert.	109.630	QP	26.7	11.7	8.1	30.2	16.4	43.5	27.1	
Vert.	181.723	QP	25.9	16.2	8.8	29.7	21.2	43.5	22.3	
Vert.	286.775	QP	25.2	13.3	9.7	29.2	19.0	46.0	27.0	
Vert.	432.295	QP	24.0	16.1	10.7	29.8	21.0	46.0	25.0	
Vert.	721.001	QP	22.0	20.0	12.1	29.3	24.9	46.0	21.2	

Result = Reading + Ant Factor + Loss (Cable+Attenuator) - Gain(Amplifier)

*Other frequency noises omitted in this report were not seen or had enough margin (more than 20 dB).

*The test result is rounded off to one or two decimal places, so some differences might be observed.

UL Japan, Inc.

Ise EMC Lab.

4383-326 Asama-cho, Ise-shi, Mie-ken 516-0021 JAPAN

Telephone : +81 596 24 8999

Facsimile : +81 596 24 8124

Radiated Emission above 30 MHz (Spurious Emission)

Report No. 13226969H
Test place Ise EMC Lab.
Semi Anechoic Chamber No.2
Date 05/14/2020
Temperature / Humidity 23 deg. C / 44 % RH
Engineer Ken Fujita
Mode Mode 7 (10 W)

Polarity	Frequency [MHz]	Detector	Reading [dBuV]	Ant.Fac. [dB/m]	Loss [dB]	Gain [dB]	Result [dBuV/m]	Limit [dBuV/m]	Margin [dB]	Remark
Hori.	80.099	QP	32.3	6.8	7.8	30.3	16.6	40.0	23.4	
Hori.	109.833	QP	26.3	11.8	8.1	30.2	16.0	43.5	27.5	
Hori.	181.794	QP	25.7	16.2	8.8	29.7	21.0	43.5	22.5	
Hori.	286.746	QP	26.9	13.3	9.7	29.2	20.7	46.0	25.3	
Hori.	436.308	QP	24.5	16.2	10.7	29.9	21.6	46.0	24.5	
Hori.	721.229	QP	22.0	20.0	12.1	29.3	24.9	46.0	21.2	
Vert.	80.099	QP	38.0	6.8	7.8	30.3	22.3	40.0	17.7	
Vert.	109.833	QP	26.6	11.8	8.1	30.2	16.3	43.5	27.2	
Vert.	181.794	QP	25.6	16.2	8.8	29.7	20.9	43.5	22.6	
Vert.	286.746	QP	25.7	13.3	9.7	29.2	19.5	46.0	26.5	
Vert.	436.308	QP	25.4	16.2	10.7	29.9	22.5	46.0	23.6	
Vert.	721.229	QP	22.0	20.0	12.1	29.3	24.9	46.0	21.2	

Result = Reading + Ant Factor + Loss (Cable+Attenuator) - Gain(Amplifier)

*Other frequency noises omitted in this report were not seen or had enough margin (more than 20 dB).

*The test result is rounded off to one or two decimal places, so some differences might be observed.

UL Japan, Inc.

Ise EMC Lab.

4383-326 Asama-cho, Ise-shi, Mie-ken 516-0021 JAPAN

Telephone : +81 596 24 8999

Facsimile : +81 596 24 8124

Radiated Emission above 30 MHz (Spurious Emission)

Report No. 13226969H
Test place Ise EMC Lab.
Semi Anechoic Chamber No.2
Date 05/14/2020
Temperature / Humidity 23 deg. C / 44 % RH
Engineer Ken Fujita
Mode Mode 8 (10 W)

Polarity	Frequency [MHz]	Detector	Reading [dBuV]	Ant.Fac. [dB/m]	Loss [dB]	Gain [dB]	Result [dBuV/m]	Limit [dBuV/m]	Margin [dB]	Remark
Hori.	80.653	QP	33.7	6.9	7.8	30.3	18.1	40.0	21.9	
Hori.	109.435	QP	26.8	11.7	8.1	30.2	16.4	43.5	27.1	
Hori.	181.730	QP	25.8	16.2	8.8	29.7	21.1	43.5	22.4	
Hori.	287.730	QP	27.7	13.3	9.7	29.2	21.5	46.0	24.5	
Hori.	432.199	QP	26.8	16.1	10.7	29.8	23.8	46.0	22.3	
Hori.	721.283	QP	22.0	20.0	12.1	29.3	24.9	46.0	21.2	
Vert.	80.653	QP	37.0	6.9	7.8	30.3	21.4	40.0	18.6	
Vert.	109.435	QP	26.8	11.7	8.1	30.2	16.4	43.5	27.1	
Vert.	181.730	QP	25.7	16.2	8.8	29.7	21.0	43.5	22.5	
Vert.	287.730	QP	25.1	13.3	9.7	29.2	18.9	46.0	27.1	
Vert.	432.199	QP	24.3	16.1	10.7	29.8	21.3	46.0	24.8	
Vert.	721.283	QP	22.0	20.0	12.1	29.3	24.9	46.0	21.2	

Result = Reading + Ant Factor + Loss (Cable+Attenuator) - Gain(Amplifier)

*Other frequency noises omitted in this report were not seen or had enough margin (more than 20 dB).

*The test result is rounded off to one or two decimal places, so some differences might be observed.

UL Japan, Inc.

Ise EMC Lab.

4383-326 Asama-cho, Ise-shi, Mie-ken 516-0021 JAPAN

Telephone : +81 596 24 8999

Facsimile : +81 596 24 8124

Radiated Emission above 30 MHz (Spurious Emission)

Report No. 13226969H
Test place Ise EMC Lab.
Semi Anechoic Chamber No.2
Date 05/14/2020
Temperature / Humidity 23 deg. C / 44 % RH
Engineer Ken Fujita
Mode Mode 9 (10 W)

Polarity	Frequency [MHz]	Detector	Reading [dBuV]	Ant.Fac. [dB/m]	Loss [dB]	Gain [dB]	Result [dBuV/m]	Limit [dBuV/m]	Margin [dB]	Remark
Hori.	80.124	QP	30.7	6.8	7.8	30.3	15.0	40.0	25.0	
Hori.	109.634	QP	26.7	11.7	8.1	30.2	16.4	43.5	27.1	
Hori.	181.734	QP	26.3	16.2	8.8	29.7	21.6	43.5	21.9	
Hori.	287.657	QP	27.3	13.3	9.7	29.2	21.1	46.0	24.9	
Hori.	432.534	QP	26.4	16.1	10.7	29.8	23.4	46.0	22.6	
Hori.	721.645	QP	22.0	20.0	12.1	29.3	24.9	46.0	21.2	
Vert.	80.124	QP	37.8	6.8	7.8	30.3	22.1	40.0	17.9	
Vert.	109.634	QP	27.1	11.7	8.1	30.2	16.8	43.5	26.7	
Vert.	181.734	QP	25.8	16.2	8.8	29.7	21.1	43.5	22.4	
Vert.	287.657	QP	26.4	13.3	9.7	29.2	20.2	46.0	25.8	
Vert.	432.534	QP	24.1	16.1	10.7	29.8	21.1	46.0	24.9	
Vert.	721.645	QP	22.0	20.0	12.1	29.3	24.9	46.0	21.2	

Result = Reading + Ant Factor + Loss (Cable+Attenuator) - Gain(Amplifier)

*Other frequency noises omitted in this report were not seen or had enough margin (more than 20 dB).

*The test result is rounded off to one or two decimal places, so some differences might be observed.

UL Japan, Inc.

Ise EMC Lab.

4383-326 Asama-cho, Ise-shi, Mie-ken 516-0021 JAPAN

Telephone : +81 596 24 8999

Facsimile : +81 596 24 8124

Radiated Emission above 30 MHz (Spurious Emission)

Report No. 13226969H
Test place Ise EMC Lab.
Semi Anechoic Chamber No.2
Date 05/14/2020
Temperature / Humidity 23 deg. C / 44 % RH
Engineer Ken Fujita
Mode Mode 10 (10 W)

Polarity	Frequency [MHz]	Detector	Reading [dBuV]	Ant.Fac. [dB/m]	Loss [dB]	Gain [dB]	Result [dBuV/m]	Limit [dBuV/m]	Margin [dB]	Remark
Hori.	80.121	QP	31.3	6.8	7.8	30.3	15.6	40.0	24.4	
Hori.	109.765	QP	26.5	11.7	8.1	30.2	16.2	43.5	27.3	
Hori.	181.734	QP	26.4	16.2	8.8	29.7	21.7	43.5	21.8	
Hori.	287.840	QP	27.4	13.3	9.7	29.2	21.2	46.0	24.8	
Hori.	432.432	QP	26.5	16.1	10.7	29.8	23.5	46.0	22.5	
Hori.	721.640	QP	22.0	20.0	12.1	29.3	24.9	46.0	21.2	
Vert.	80.121	QP	35.1	6.8	7.8	30.3	19.4	40.0	20.6	
Vert.	109.765	QP	27.3	11.7	8.1	30.2	17.0	43.5	26.5	
Vert.	181.734	QP	25.5	16.2	8.8	29.7	20.8	43.5	22.7	
Vert.	287.840	QP	26.4	13.3	9.7	29.2	20.2	46.0	25.8	
Vert.	432.432	QP	24.4	16.1	10.7	29.8	21.4	46.0	24.6	
Vert.	721.640	QP	22.0	20.0	12.1	29.3	24.9	46.0	21.2	

Result = Reading + Ant Factor + Loss (Cable+Attenuator) - Gain(Amplifier)

*Other frequency noises omitted in this report were not seen or had enough margin (more than 20 dB).

*The test result is rounded off to one or two decimal places, so some differences might be observed.

UL Japan, Inc.

Ise EMC Lab.

4383-326 Asama-cho, Ise-shi, Mie-ken 516-0021 JAPAN

Telephone : +81 596 24 8999

Facsimile : +81 596 24 8124

Radiated Emission above 30 MHz (Spurious Emission)

Report No. 13226969H
Test place Ise EMC Lab.
Semi Anechoic Chamber No.2
Date 05/14/2020
Temperature / Humidity 23 deg. C / 44 % RH
Engineer Ken Fujita
Mode Mode 11 (10 W)

Polarity	Frequency [MHz]	Detector	Reading [dBuV]	Ant.Fac. [dB/m]	Loss [dB]	Gain [dB]	Result [dBuV/m]	Limit [dBuV/m]	Margin [dB]	Remark
Hori.	80.121	QP	33.0	6.8	7.8	30.3	17.3	40.0	22.7	
Hori.	109.546	QP	26.6	11.7	8.1	30.2	16.3	43.5	27.2	
Hori.	181.645	QP	26.5	16.2	8.8	29.7	21.8	43.5	21.7	
Hori.	287.847	QP	27.5	13.3	9.7	29.2	21.3	46.0	24.7	
Hori.	432.639	QP	26.7	16.1	10.7	29.8	23.7	46.0	22.3	
Hori.	721.436	QP	22.0	20.0	12.1	29.3	24.9	46.0	21.2	
Vert.	80.121	QP	33.0	6.8	7.8	30.3	17.3	40.0	22.7	
Vert.	109.546	QP	27.0	11.7	8.1	30.2	16.7	43.5	26.8	
Vert.	181.645	QP	25.6	16.2	8.8	29.7	20.9	43.5	22.6	
Vert.	287.847	QP	26.5	13.3	9.7	29.2	20.3	46.0	25.7	
Vert.	432.639	QP	24.5	16.1	10.7	29.8	21.5	46.0	24.5	
Vert.	721.436	QP	22.0	20.0	12.1	29.3	24.9	46.0	21.2	

Result = Reading + Ant Factor + Loss (Cable+Attenuator) - Gain(Amplifier)

*Other frequency noises omitted in this report were not seen or had enough margin (more than 20 dB).

*The test result is rounded off to one or two decimal places, so some differences might be observed.

UL Japan, Inc.

Ise EMC Lab.

4383-326 Asama-cho, Ise-shi, Mie-ken 516-0021 JAPAN

Telephone : +81 596 24 8999

Facsimile : +81 596 24 8124

Radiated Emission Plot data, Worst case

Report No.	13226969H
Test place	Ise EMC Lab.
Semi Anechoic Chamber	No.2
Date	05/13/2020
Temperature / Humidity	20 deg. C / 40 % RH
Engineer	Tomohisa Nakagawa
Mode	Mode 6 (10 W)

(below 30MHz)

Limit : FCC15.209(a), 9-90kHz:PK, 110-490kHz:PK, other:QP

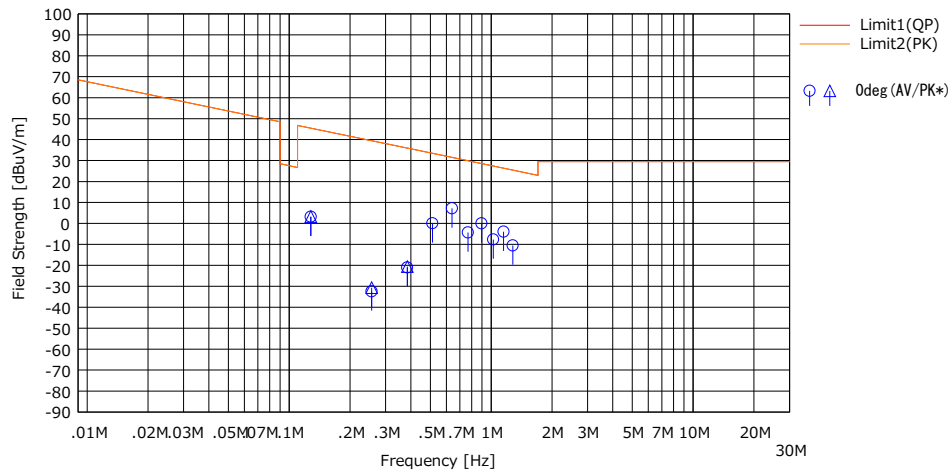

* Data above 490 kHz were measured using a QP detector.

UL Japan, Inc.

Ise EMC Lab.

4383-326 Asama-cho, Ise-shi, Mie-ken 516-0021 JAPAN

Telephone : +81 596 24 8999

Facsimile : +81 596 24 8124

Radiated Emission Plot data, Worst case

Report No. 13226969H
Test place Ise EMC Lab.
Semi Anechoic Chamber No.1
Date 04/01/2020
Temperature / Humidity 21 deg. C / 52 % RH
Engineer Takeshi Hiyaji
Mode Mode 2 (10 W)

(above 30MHz)

Limit : FCC15.209 3 m, below 1 GHz:QP, above 1 GHz:AV/PK

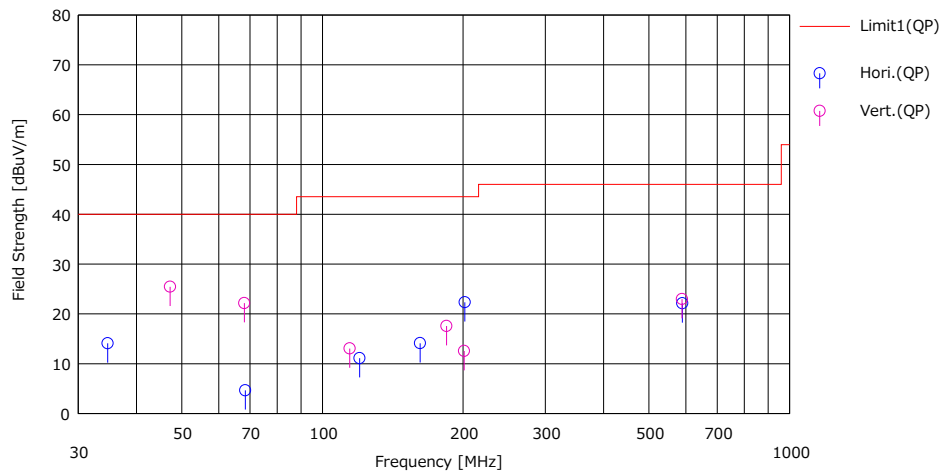

*These plots data contains sufficient number to show the trend of characteristic features for EUT.

UL Japan, Inc.

Ise EMC Lab.

4383-326 Asama-cho, Ise-shi, Mie-ken 516-0021 JAPAN

Telephone : +81 596 24 8999

Facsimile : +81 596 24 8124

-26 dB Bandwidth and 99% Occupied Bandwidth

Report No. 13226969H
 Test place Ise EMC Lab.
 Semi Anechoic Chamber No.1
 Date 04/01/2020
 Temperature / Humidity 21 deg. C / 52 % RH
 Engineer Takeshi Hiyaji
 Mode Mode 1 (5 W)

-26 dB Bandwidth [kHz]	99 % Occupied Bandwidth [kHz]
35.216	26.5283

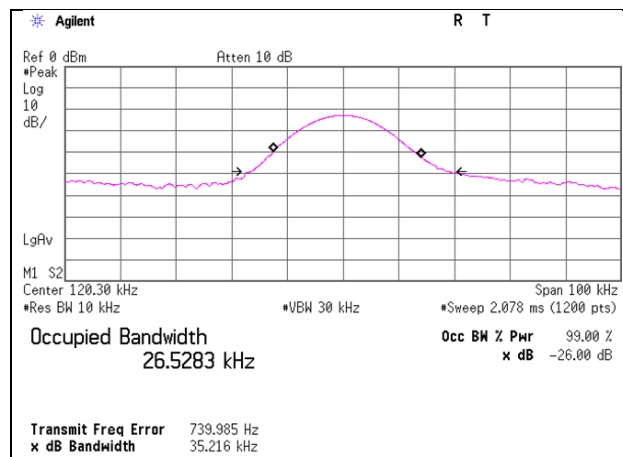

UL Japan, Inc.

Ise EMC Lab.

4383-326 Asama-cho, Ise-shi, Mie-ken 516-0021 JAPAN

Telephone : +81 596 24 8999

Facsimile : +81 596 24 8124

-26 dB Bandwidth and 99 % Occupied Bandwidth

Report No. 13226969H
 Test place Ise EMC Lab.
 Semi Anechoic Chamber No.1
 Date 04/01/2020
 Temperature / Humidity 21 deg. C / 52 % RH
 Engineer Takeshi Hiyaji
 Mode Mode 2 (10 W)

-26 dB Bandwidth [kHz]	99 % Occupied Bandwidth [kHz]
32.813	24.8048

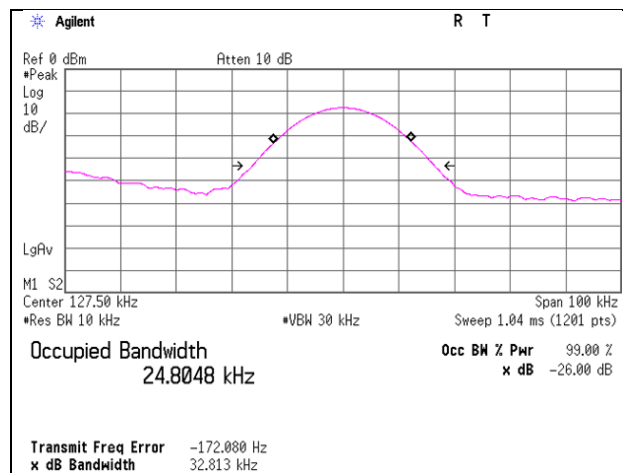

-26 dB Bandwidth and 99 % Occupied Bandwidth

Report No.	13226969H
Test place	Ise EMC Lab.
Semi Anechoic Chamber	No.2
Date	05/15/2020
Temperature / Humidity	23 deg. C / 49 % RH
Engineer	Junki Nagatomi
Mode	Mode 3 (5 W)

-26 dB Bandwidth [kHz]	99 % Occupied Bandwidth [kHz]
33.418	25.9538

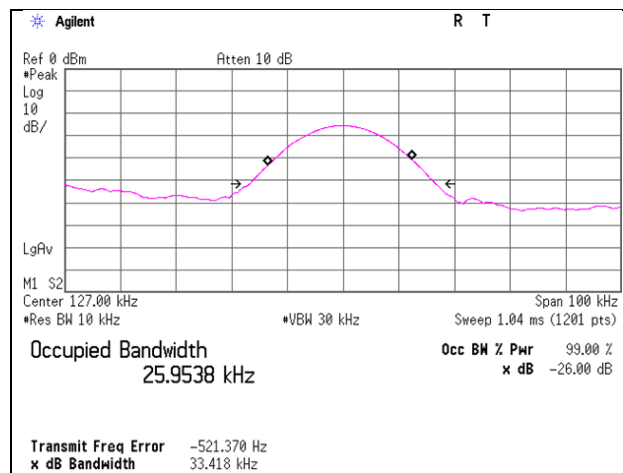

UL Japan, Inc.

Ise EMC Lab.

4383-326 Asama-cho, Ise-shi, Mie-ken 516-0021 JAPAN

Telephone : +81 596 24 8999

Facsimile : +81 596 24 8124

-26 dB Bandwidth and 99 % Occupied Bandwidth

Report No. 13226969H
 Test place Ise EMC Lab.
 Semi Anechoic Chamber No.1
 Date 05/12/2020
 Temperature / Humidity 20 deg. C / 40 % RH
 Engineer Tomohisa Nakagawa
 Mode Mode 4 (10 W)

-26 dB Bandwidth [kHz]	99 % Occupied Bandwidth [kHz]
1.073	1.0310

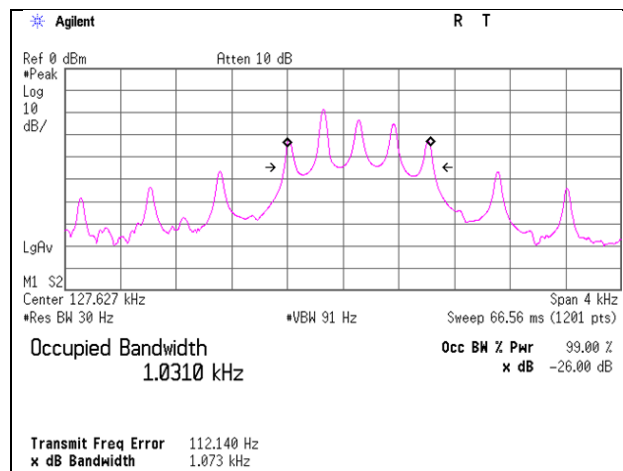

UL Japan, Inc.

Ise EMC Lab.

4383-326 Asama-cho, Ise-shi, Mie-ken 516-0021 JAPAN

Telephone : +81 596 24 8999

Facsimile : +81 596 24 8124

-26 dB Bandwidth and 99 % Occupied Bandwidth

Report No.	13226969H
Test place	Ise EMC Lab.
Semi Anechoic Chamber	No.1
Date	05/12/2020
Temperature / Humidity	20 deg. C / 40 % RH
Engineer	Tomohisa Nakagawa
Mode	Mode 5 (10 W)

-26 dB Bandwidth [kHz]	99 % Occupied Bandwidth [kHz]
1.585	1.5530

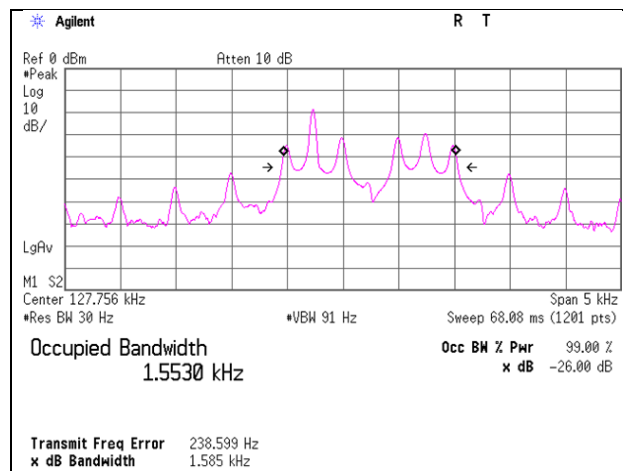

UL Japan, Inc.

Ise EMC Lab.

4383-326 Asama-cho, Ise-shi, Mie-ken 516-0021 JAPAN

Telephone : +81 596 24 8999

Facsimile : +81 596 24 8124

-26 dB Bandwidth and 99 % Occupied Bandwidth

Report No. 13226969H
 Test place Ise EMC Lab.
 Semi Anechoic Chamber No.1
 Date 05/12/2020
 Temperature / Humidity 20 deg. C / 40 % RH
 Engineer Tomohisa Nakagawa
 Mode Mode 6 (10 W)

-26 dB Bandwidth [kHz]	99 % Occupied Bandwidth [kHz]
3.626	3.4121

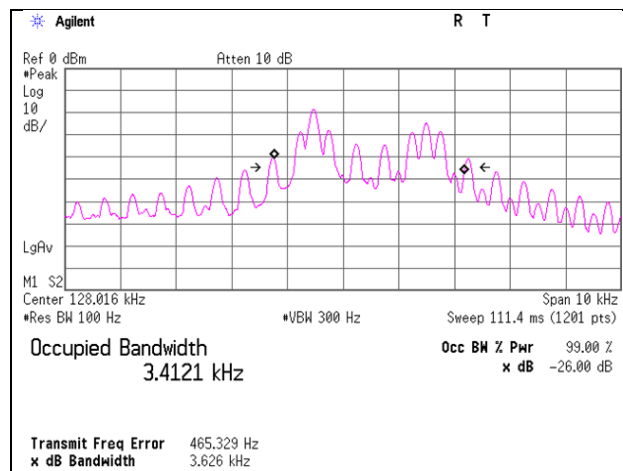

UL Japan, Inc.

Ise EMC Lab.

4383-326 Asama-cho, Ise-shi, Mie-ken 516-0021 JAPAN

Telephone : +81 596 24 8999

Facsimile : +81 596 24 8124

-26 dB Bandwidth and 99 % Occupied Bandwidth

Report No. 13226969H
 Test place Ise EMC Lab.
 Semi Anechoic Chamber No.1
 Date 05/12/2020
 Temperature / Humidity 20 deg. C / 40 % RH
 Engineer Tomohisa Nakagawa
 Mode Mode 7 (10 W)

-26 dB Bandwidth [kHz]	99 % Occupied Bandwidth [kHz]
6.273	5.7232

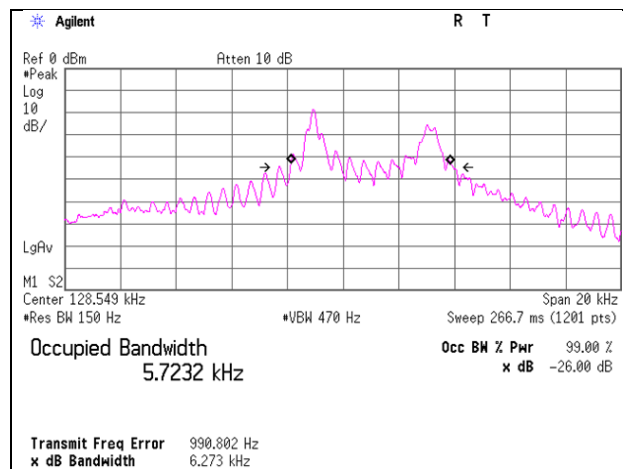

-26 dB Bandwidth and 99 % Occupied Bandwidth

Report No. 13226969H
 Test place Ise EMC Lab.
 Semi Anechoic Chamber No.1
 Date 05/12/2020
 Temperature / Humidity 20 deg. C / 40 % RH
 Engineer Tomohisa Nakagawa
 Mode Mode 8 (10 W)

-26 dB Bandwidth [kHz]	99 % Occupied Bandwidth [kHz]
1.069	1.0270

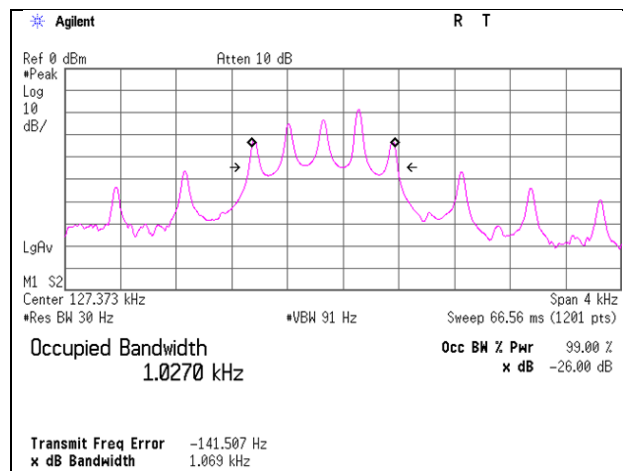

UL Japan, Inc.

Ise EMC Lab.

4383-326 Asama-cho, Ise-shi, Mie-ken 516-0021 JAPAN

Telephone : +81 596 24 8999

Facsimile : +81 596 24 8124

-26 dB Bandwidth and 99 % Occupied Bandwidth

Report No.	13226969H
Test place	Ise EMC Lab.
Semi Anechoic Chamber	No.1
Date	05/12/2020
Temperature / Humidity	20 deg. C / 40 % RH
Engineer	Tomohisa Nakagawa
Mode	Mode 9 (10 W)

-26 dB Bandwidth [kHz]	99 % Occupied Bandwidth [kHz]
2.501	1.5409

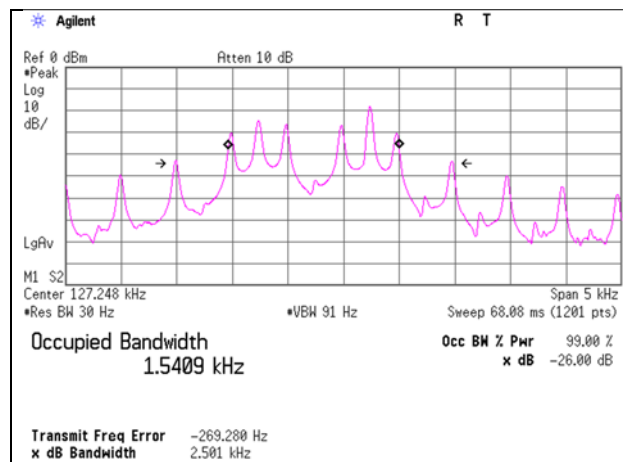

UL Japan, Inc.

Ise EMC Lab.

4383-326 Asama-cho, Ise-shi, Mie-ken 516-0021 JAPAN

Telephone : +81 596 24 8999

Facsimile : +81 596 24 8124

-26 dB Bandwidth and 99 % Occupied Bandwidth

Report No. 13226969H
 Test place Ise EMC Lab.
 Semi Anechoic Chamber No.1
 Date 05/12/2020
 Temperature / Humidity 20 deg. C / 40 % RH
 Engineer Tomohisa Nakagawa
 Mode Mode 10 (10 W)

-26 dB Bandwidth [kHz]	99 % Occupied Bandwidth [kHz]
3.574	3.2913

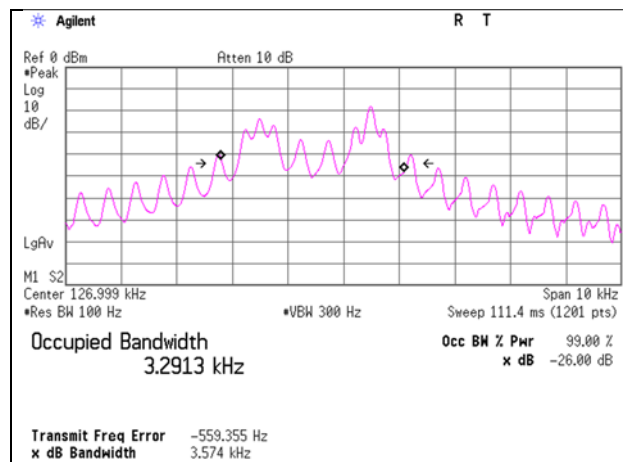

UL Japan, Inc.

Ise EMC Lab.

4383-326 Asama-cho, Ise-shi, Mie-ken 516-0021 JAPAN

Telephone : +81 596 24 8999

Facsimile : +81 596 24 8124

-26 dB Bandwidth and 99 % Occupied Bandwidth

Report No.	13226969H
Test place	Ise EMC Lab.
Semi Anechoic Chamber	No.1
Date	05/12/2020
Temperature / Humidity	20 deg. C / 40 % RH
Engineer	Tomohisa Nakagawa
Mode	Mode 11 (10 W)

-26 dB Bandwidth [kHz]	99 % Occupied Bandwidth [kHz]
5.994	5.4211

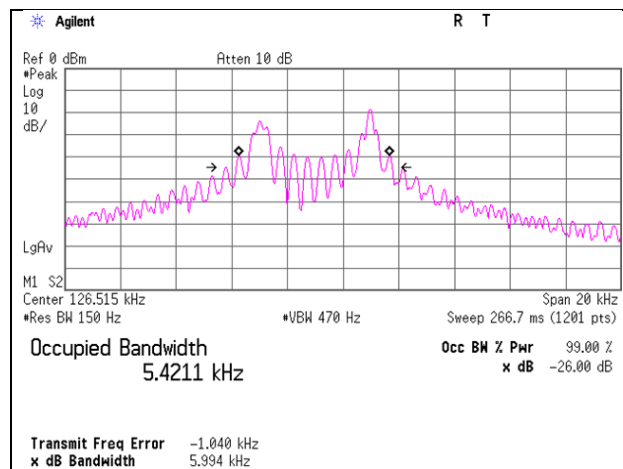

UL Japan, Inc.

Ise EMC Lab.

4383-326 Asama-cho, Ise-shi, Mie-ken 516-0021 JAPAN

Telephone : +81 596 24 8999

Facsimile : +81 596 24 8124

APPENDIX 2: Test instruments

Test equipment

Test Item	Local ID	LIMS ID	Description	Manufacturer	Model	Serial	Last Calibration Date	Cal Int
RE	MPA-14	141583	Pre Amplifier	SONOMA INSTRUMENT	310	260833	02/18/2020	12
RE	MAT-08	141213	Attenuator(6dB)	Weinschel Corp	2	BK7971	11/14/2019	12
RE	MCC-03	141215	Coaxial Cable	Fujikura/Suhner/TSJ	5D-2W/3D-2W/RG400u/RFM-E421(SW)	-/01068(Switcher)	06/27/2019	12
RE	MCC-143	141413	Coaxial Cable	UL Japan	-	-	06/07/2019	12
RE	MCC-02	141350	Coaxial Cable	Suhner/storm/Agilent/TSJ	-	-	06/27/2019	12
RE	MLPA-01	141254	Loop Antenna	Rohde & Schwarz	HFH2-Z2	100017	10/04/2019	12
RE	MAEC-01	141998	AC1_Semi Anechoic Chamber(NSA)	TDK	Semi Anechoic Chamber 10m	DA-06881	06/18/2018	24
RE	MTR-09	141950	EMI Test Receiver	Rohde & Schwarz	ESU26	100412	06/27/2019	12
RE	KBA-05	141198	Biconical Antenna	Schwarzbeck Mess - Elektronik	VHA9103+BBA9106	2513	04/22/2020	12
RE	MLA-20	141264	Logperiodic Antenna(200-1000MHz)	Schwarzbeck Mess - Elektronik	VUSLP9111B	9111B-189	04/22/2020	12
RE	MOS-27	141566	Thermo-Hygrometer	CUSTOM	CTH-201	A08Q26	01/07/2020	12
RE	MMM-03	141530	Digital Tester	Fluke Corporation	FLUKE 26-3	78030621	08/20/2019	12
RE	COTS-MEMI-02	178648	EMI measurement program	TSJ	TEPTO-DV	-	-	-
RE	MJM-25	142226	Measure	KOMELON	KMC-36	-	-	-
RE	MSA-03	141884	Spectrum Analyzer	Keysight Technologies Inc	E4448A	MY44020357	03/04/2020	12
RE	MAEC-03	142008	AC3_Semi Anechoic Chamber(NSA)	TDK	Semi Anechoic Chamber 3m	DA-10005	06/26/2018	24
RE	MOS-13	141554	Thermo-Hygrometer	CUSTOM	CTH-201	1301	01/07/2020	12
RE	MMM-08	141532	DIGITAL HiTESTER	Hioki	3805	51201197	01/06/2020	12
RE	MJM-16	142183	Measure	KOMELON	KMC-36	-	-	-
RE	MAT-95	142314	Attenuator	Pasternack	PE7390-6	D/C 1504	06/11/2019	12
RE	MBA-03	141424	Biconical Antenna	Schwarzbeck Mess - Elektronik	VHA9103+BBA9106	1915	08/24/2019	12
RE	MCC-51	141323	Coaxial cable	UL Japan	-	-	07/02/2019	12
RE	MLA-22	141266	Logperiodic Antenna(200-1000MHz)	Schwarzbeck Mess - Elektronik	VUSLP9111B	9111B-191	08/24/2019	12
RE	MPA-13	141582	Pre Amplifier	SONOMA INSTRUMENT	310	260834	02/10/2020	12
RE	TR-08	146754	Test Receiver	Rohde & Schwarz	ESCI	100299	10/08/2019	12

*Hyphens for Last Calibration Date and Cal Int (month) are instruments that Calibration is not required (e.g. software), or instruments checked in advance before use.

The expiration date of the calibration is the end of the expired month.

As for some calibrations performed after the tested dates, those test equipment have been controlled by means of an unbroken chains of calibrations.

All equipment is calibrated with valid calibrations. Each measurement data is traceable to the national or international standards.

Test item:

RE: Spurious emission

UL Japan, Inc.

Ise EMC Lab.

4383-326 Asama-cho, Ise-shi, Mie-ken 516-0021 JAPAN

Telephone : +81 596 24 8999

Facsimile : +81 596 24 8124