

# ELECTROMAGNETIC EMISSIONS TEST REPORT

FCC Part 15, Subpart C, Section 15.247

Operation within the bands 902-928MHz, 2400-2483.5MHz and 5725-5850MHz

Name of Appliances : Bluetooth Module

Model No. (Type) : WCA-008-XX

Test report No. : CSF-11034

## Panasonic EMC Standard Site

### Panasonic Corporation

Yashiro Sasayama-City,

Hyogo 669-2356

Japan

Tel 079-552-5681

Fax 079-552-5682

Received : September 27, 2011

Completed : November 11, 2011

This test report with appendix consists of 27 pages.

The test results respond to the tested sample only.

It is not allowed to copy this report even partly without the allowance of the test laboratory.

This test report must not be used to claim product endorsement by NVLAP or any agency of the U.S. Government.



Masayuki Ueda

Chief Engineer of Panasonic EMC Standard Site

Date: November 11, 2011

# TABLE OF CONTENTS

Page

<b>1.0 ENGINEERING TEST REPORT .....</b>	<b>4</b>
<b>2.0 INTRODUCTION.....</b>	<b>7</b>
2.1 Purpose .....	7
2.2 Deviation from the standards .....	7
2.3 Requirement.....	7
2.3.1 FCC Section 15.203.....	7
2.3.2 FCC Section 15.205.....	7
2.3.3 FCC Section 15.207.....	7
2.3.4 FCC Section 15.209.....	8
Radiated emission limits (Above 1GHz) .....	8
2.3.5 FCC Section 15.247(a)(1).....	9
2.3.6 FCC Section 15.247(a)(1)(iii).....	9
2.3.7 FCC Section 15.247(b)(1).....	9
2.3.8 FCC Section 15.247(d) .....	9
2.4 Short Description of the EUT .....	10
2.5 Equipment Under Test .....	10
2.5.1 Operation - mode of the EUT .....	10
2.5.2 Modification of the EUT.....	11
2.5.3 The Equipment Under Test (EUT) and Peripherals.....	11
2.5.4 Details of ports .....	12
2.5.5 Type of Interface Cables .....	12
2.5.6 Abbreviations of the Cable type and Ferrite.....	13
2.5.7 Block diagram of the Equipment Under Test (EUT) :.....	14
2.6 Environmental Conditions .....	15
<b>3.0 TEST SITE DESCRIPTION.....</b>	<b>16</b>
<b>4.0 TEST INSTRUMENTATION.....</b>	<b>17</b>
4.1 Table 4-1 .....	17
4.2 Table 4-2 .....	18
4.3 Table 4-3 .....	19
4.4 Table 4-4 .....	19
4.5 Table 4-5 .....	20
4.6 Table 4-6 .....	20
<b>5.0 TEST EUT SETUP AND CONFIGURATIONS .....</b>	<b>21</b>
5.1 Technical Requirements .....	21
5.1.1 Hopping Characteristics.....	21
5.1.2 20dB Bandwidth .....	21
5.1.3 Peak Transmitter Output Power .....	21
5.1.4 Antenna Conducted Spurious Emissions.....	21

5.1.5 AC Power Line Conducted Emission of Transmitter ..... 22

5.1.6 Radiated Emission of Transmitter (Spurious and Harmonics, Band Edge) ..... 23

5.1.7 Band Edge ..... 26

**6.0 TEST RESULTS ..... 27**

6.1 Hopping Characteristics ..... 27

6.2 20dB Bandwidth ..... 27

6.3 Peak Transmitter Output Power ..... 27

6.4 Antenna Conducted Spurious Emissions ..... 27

6.5 AC Power Line Conducted Emission of Transmitter ..... 27

6.6 9k - 25G Radiated Emission of Transmitter (Spurious and Harmonics) ..... 27

6.7 Band Edge (Radiated Test) ..... 27

Attachments

A Test Data ..... A1-A44

B Test Setup Photographs ..... B1-B6

**1.0 ENGINEERING TEST REPORT**

This report is to certify that the Bluetooth Module, WCA-008-XX from which the following data has been derived properly complies with the requirements of "FCC Rules and Regulations Part 15 Subpart C" as of the date the measurements were made. Any modification to the unit as tested may invalidate the data and void this certification.

- |                             |   |   |
|-----------------------------|---|---|
| 1. Applicant                | : | Panasonic Healthcare Co., Ltd.<br>Hearing Instruments Business Unit                 |
| Address                     | : | 600 Saedo-cho, Tsuzuki-ku, Yokohama, Kanagawa<br>224-8539, Japan                    |
| 2. Manufacturer             | : | Panasonic Healthcare Co., Ltd<br>Hearing Instruments Business Unit                  |
| Address                     | : | 600 Saedo-cho, Tsuzuki-ku, Yokohama, Kanagawa<br>224-8539, Japan                    |
| 3. Factory1                 | : | Panasonic Healthcare Co., Ltd.<br>Hearing Instruments Business Unit Saijo Seizousyo |
| Address1                    | : | 247 Fukutake-ko, Saijo, Ehime 793-8510, Japan                                       |
| 4. Factory2                 | : | PT Panasonic Healthcare Indonesia   |
| Address2                    | : | Kawasan Industri MM2100 Blok O-1 Cikarang Barat,<br>Bekasi 17520, INDONESIA         |
| 5. Description of Appliance |   |   |
| a. Name of Appliance        | : | Bluetooth Module  |
| b. Equipment authorization  | : | Certification   |
| c. FCC ID.                  | : | ACJ927153TX   |
| d. Model No                 | : | WCA-008-XX<br>(XX is the Firmware Code.<br>For example: ST, AT or CT)               |
| e. Serial No.               | : | SN 00000007   |
| f. Date of Manufacture      | : | June 2011   |

(continued)

- g. Power Supply : 3.0V DC and 1.8V DC
- h. EUT Condition : Pre-Production (Client samples)
- i. Modulation type : Frequency Hopping Spread Spectrum  
(GFSK,  $\pi/4$ DQPSK, 8DPSK)
- j. Transmit Speed : 1 / 2 / 3 Mbps
- k. Number of Channels : 79
- l. Antenna type : Chip Antenna
- m. Operation frequency : 2402-2480 MHz
- n. Oscillating Frequency :

Clock Type	Destination	Frequency[MHz]
Analog clock	Reference Oscillator	26 MHz
Digital clock	Clock Generation	16 MHz
RF TXVCO1	RF Synthesiser	1602 ~ 1654MHz
RF TXVCO2	RF Synthesiser	801 ~ 827MHz
RF RXVCO1	RF Synthesiser	1600.33 ~ 1652.33MHz
RF RXVCO2	RF Synthesiser	800.16 ~ 826.16MHz
RF TX	RF Transmitter	2402 ~ 2480MHz

- 6. Measurement Site : Panasonic EMC Standard Site
- 7. Date of Measurement : September 27, 2011  
September 28, 2011  
September 29, 2011  
October 4, 2011  
October 12, 2011  
October 13, 2011  
November 11, 2011

(continued)

8. Summary of Measurement Results (Results of the tests please see attachment A.)
- a. Antenna Requirements : Compliance
  - b. Restricted Bands of Operation : Compliance
  - c. Hopping Characteristics
    - Carrier Frequency Separation : Compliance
    - Number of Hopping Frequencies : Compliance
    - Average Time of Occupancy : Compliance
  - d. 20dB Bandwidth : Compliance
  - e. Peak Transmitter Output Power : Compliance
  - f. Antenna Conducted Spurious Emission : Compliance
  - g. AC Power Line Conducted Emission of Transmitter : Compliance
  - h. Radiated Emission of Transmitter (Spurious and Harmonics) : Compliance
  - i. Band Edge (Radiated Test) : Compliance

The EUT complied with FCC rules and regulations.

These test results are traceable to the National and International Standards.

Measurement Uncertainty, at time of test, and at least 95% confidence, was estimated to be as follows:

Radiated Emission Measurement : 2.6 dB  
Conducted Emission Measurement : 1.9 dB



Masayuki Ueda  
Chief Engineer of Panasonic EMC Standard Site  
Date: November 11, 2011

## 2.0 INTRODUCTION

### 2.1 Purpose

The purpose of this report is to show compliance of the Bluetooth Module, WCA-008-XX to the requirement of Part 15 of the FCC Rules and Regulations (47 CFR, PART 15, Subpart C) and FCC Procedure for Measuring RF Emissions from ANSI C63.4-2003 and Public Notice DA 00-705 (March 30, 2000)

### 2.2 Deviation from the standards

Deviations from or additions to the test method: No deviation or addition

### 2.3 Requirement

The test requirements for an intentional Radiator are as follows.

In the evaluation, limits for the requirements of the FCC Rules and Regulations, Part 15 Subpart C applies Sections 15.203, 15.205, 15.207, 15.209, 15.247(a)(1), 15.247(a)(1)(iii), 15.247(b)(1) and 15.247(d).

#### 2.3.1 FCC Section 15.203

An intentional radiator shall be designed to ensure that no antenna other than that furnished by the responsible party shall be used with the device.

Verdict: (options and interpretation)

The antenna is soldered to the EUT's PCB and cannot be removed. Hence the EUT complies with the requirements.

#### 2.3.2 FCC Section 15.205

Only spurious emissions are permitted in any of the restricted frequency bands, unless otherwise specified.

Verdict: (options and interpretation)

The EUT nominal carrier frequency is 2402 – 2480 MHz. It was verified during testing that the carrier is fully contained in the unrestricted frequency band 2390 – 2483.5 MHz.

Therefore only spurious emissions are found in the restricted bands of operation and the EUT complies with the restricted frequency band requirement.

#### 2.3.3 FCC Section 15.207

Conducted emission limits

Frequency (MHz)	Conducted limit (dB $\mu$ V)	
	OP	AV
0.15 – 0.50	66.0 – 56.0	56.0 – 46.0
0.50 – 5.00	56.0	46.0
5.00 – 30.00	60.0	50.0

(continued)

2.3.4 FCC Section 15.209

Radiated emission limits (Below 1GHz)

Frequency (MHz)	Field Strength ( $\mu\text{V/m}$ )	Measurement Distance (m)
	QP	
0.009 – 0.490	2400/F(kHz)	300
0.490 – 1.705	24000/F(kHz)	30
1.705 – 30.0	30	30
30.0 – 88.0	100	3
88.0 – 216.0	150	3
216.0 – 960.0	200	3
960.0 –	500	3

Frequency (MHz)	Field Strength ( $\text{dB}\mu\text{V/m}$ )	Measurement Distance (m)
	QP	
0.009 – 0.490	128.5 – 93.8	3
0.490 – 1.705	73.8 – 62.96	3
1.705 – 30.0	69.5	3
30.0 – 88.0	40.0	3
88.0 – 216.0	43.5	3
216.0 – 960.0	46.0	3
960.0 – 1000.0	53.9	3

Radiated emission limits (Above 1GHz)

Frequency (GHz)	Field Strength ( $\text{dB}\mu\text{V/m}$ )	Measurement Distance (m)
	AV	
1 – 25	54	3
	Peak	
1 – 25	74	3

The 300m limit below 0.490MHz was extrapolated to a 3m distance using a 80dB correction factor.

The 30m limit below 30MHz was extrapolated to a 3m distance using a 40dB correction factor.

(continued)

### 2.3.5 FCC Section 15.247(a)(1)

Operation under the provisions of this Section is limited to frequency hopping and digitally modulated Intentional radiators that comply with the following provisions:

Frequency hopping systems shall have hopping channel carrier frequencies separated by a minimum of 25 kHz or the 20 dB bandwidth of the hopping channel, whichever is greater. Alternatively, frequency hopping systems operating in the 2400-2483.5 MHz band may have hopping channel carrier frequencies that are separated by 25 kHz or two-thirds of the 20 dB bandwidth of the hopping channel, whichever is greater, provided the systems operate with an output power no greater than 125 mW. The system shall hop to channel frequencies that are selected at the system hopping rate from a pseudorandomly ordered list of hopping frequencies. Each frequency must be used equally on the average by each transmitter. The system receivers shall have input bandwidths that match the hopping channel bandwidths of their corresponding transmitters and shall shift frequencies in synchronization with the transmitted signals.

### 2.3.6 FCC Section 15.247(a)(1)(iii)

Operation under the provisions of this Section is limited to frequency hopping and digitally modulated Intentional radiators that comply with the following provisions:

Frequency hopping systems in the 2400-2483.5 MHz band shall use at least 15 channels. The average time of occupancy on any channel shall not be greater than 0.4 seconds within a period of 0.4 seconds multiplied by the number of hopping channels employed.

Frequency hopping systems may avoid or suppress transmissions on a particular hopping frequency provided that a minimum of 15 channels are used.

### 2.3.7 FCC Section 15.247(b)(1)

The maximum peak conducted output power of the intentional radiator shall not exceed the following:

For frequency hopping systems operating in the 2400-2483.5 MHz band employing at least 75 non-overlapping hopping channels: 1 watt.

For all other frequency hopping systems in the 2400-2483.5 MHz band: 0.125 watts.

### 2.3.8 FCC Section 15.247(d)

In any 100 kHz bandwidth outside the frequency band in which the spread spectrum or digitally modulated intentional radiator is operating, the radio frequency power that is produced by the intentional radiator shall be at least 20 dB below that in the 100 kHz bandwidth within the band that contains the highest level of the desired power, based on either an RF conducted or a radiated measurement, provided the transmitter demonstrates compliance with the peak conducted power limits. If the transmitter complies with the conducted power limits based on the use of RMS averaging over a time interval, as permitted under paragraph (b)(3) of this section, the attenuation required under this paragraph shall be 30 dB instead of 20 dB. Attenuation below the general limits specified in Section 15.209(a) is not required. In addition, radiated emissions which fall in the restricted bands, as defined in Section 15.205(a), must also comply with the radiated emission limits specified in Section 15.209(a)

(continued)

## 2.4 Short Description of the EUT

The EUT (Equipment Under Test) is a Bluetooth module subject to FCC Modular Approval. The Bluetooth module may be incorporated, for example, into a Hearing Hub or an AV transmitter used in hearing aid system.

## 2.5 Equipment Under Test

### 2.5.1 Operation - mode of the EUT

The equipment under test was operated during the measurement under following conditions:

- A. EUT transmits a modulated signal at lowest channel (2402MHz, Duty Cycle was 77%)
- B. EUT transmits a modulated signal at middle channel (2441MHz, Duty Cycle was 77%)
- C. EUT transmits at a modulated signal highest channel (2480MHz, Duty Cycle was 77%)
- D. EUT transmits on pseudo-random sequence on all channels (hopping mode)

(Bluetooth modulation type):

- 1. Bluetooth operation in BDR mode (FSK modulation)
- 2. Bluetooth operation in EDR mode (PSK modulation)

No.	Test Item	Requirement & Limit	Operation mode	Modulation type
c	Hopping Characteristics:			
	Carrier Frequency Separation	FCC §15.247(a)(1)	D	1, 2
	Number of Hopping Frequencies	FCC §15.247(a)(1)(iii)	D	1, 2
	Average Time of Occupancy	FCC §15.247(a)(1)(iii)	D	1, 2
d	20dB Bandwidth	FCC §15.247(a)(1)	A, B, C	1, 2
e	Peak Transmitter Output Power	FCC §15.247(b)(1)	A, B, C	1, 2
f	Antenna Conducted Spurious Emission	FCC §15.247(d)	A, B, C	1, 2
g	AC Power Line Conducted Emission of Transmitter	FCC §15.207	A, B, C	1, 2
h	Radiated Emission of Transmitter (Spurious and Harmonics)	FCC §15.205, 15.209 and 15.247(d)	A, B, C	1, 2
i	Band Edge (Radiated Test)	FCC §15.205, 15.209 and 15.247(d)	A, C	1, 2

(continued)

2.5.2 Modification of the EUT

The test laboratory did not modify the EUT during the test.

2.5.3 The Equipment Under Test (EUT) and Peripherals

<EUT>

Symbol	Device	Model	Serial No.	Manufacturer
A	Bluetooth module	WCA-008-XX	SN 00000007	Panasonic

Note.

- XX is the Firmware Code. For example: ST, AT or CT

<peripheral devices>

Symbol	Device	Model	Serial No.	Manufacturer	FCC ID / DoC
B	Test Jig (Audio Transmitter)	WH-0M1301A PCB	ES3 No.7	Panasonic	*1
C	AC Adapter	R68-5631R	I000227MT	Panasonic	*2
D	RS-232C I/F	UTL-004C	08K10201	HuMANDATA	*3
E	Laptop Computer	1702-7KJ	LV-K9390	lenovo	*3
F	Audio Accessory	iFP-790	802972050501105	iRiver	QDMIFP799

Notes:

\*1- The Audio Output port and the IO port of the Bluetooth Module was directly connected to and loaded by the Test Jig (B) (connection is not shown in the below 2.5.8 Block diagram)

\*2- The AC Adaptor (C) was accessory of Test Jig (B).

\*3- The Laptop Computer (E) and RS-232C I/F (D) were disconnected and removed from the test setup for testing after the proper operation mode had been set.

(continued)

2.5.4 Details of ports

Symbol	Name of port	Connection	status of lines	Analogue/ Digital	Remarks
	Audio Input	Test Jig / Player	Passive	Analogue	-
	DC Input	Test Jig / AC Adapter	Passive	Analogue	-
	UART Port	RS-232C I/F / Laptop Computer	Passive/Active	Digital	Port of peripheral devices
	AC Input	AC Adapter	Passive	Analogue	-

Note:

-The status of lines shows direction of signals on the EUT; “active“ is “OUT” and “passive“ is “IN”.

2.5.5 Type of Interface Cables

<Interface cables>

No.	Name of Cable	Model	Cable type	Shielded	Ferrite Quantity	Connector Type of shell & Connector Type	
	Name of port	Manufacturer	Length(m)				
1 (*1)	Audio Cable	K2KYYYY00184	a	Shielded	None	Plastic	φ3.5mm plug
	Audio Input	Panasonic	1.50				
2	RS-232C Cable	C232N-915	c	Shielded	None	Plastic	RS-232C 9pin
	PC RS-232C	ELECOM	1.50				

Notes:

-Explanation of the abbreviations of a Cable type and Ferrite is shown in 2.5.6.

-Audio Cable (\*1) was accessory of the Test Jig (Audio Transmitter).

< AC Power Cord >

No.	Name of Cable	Cable Type	Pin	Length (m)	Shielded	Ferrite Quantity	Ground Line
	Manufacturer / Model						
3	AC Power Cord for AC Adapter	a	2	1.55	Unshielded	None	None
	Panasonic/K2CA2YY00116						

Note:

-Explanation of the abbreviations of a Cable type and Ferrite is shown in 2.5.6.

(Continued)

< DC Power Cord >

No.	Name of Cable	Cable Type	Pin	Length (m)	Shielded	Ferrite Quantity	Ground Line
	Manufacturer / Model						
4	DC Power Cord of AC Adapter	e	2	1.95	Unshielded	None	None
	Panasonic/R68-5631R						

Note:

-Explanation of the abbreviations of a Cable type and Ferrite is shown in 2.5.6.

2.5.6 Abbreviations of the Cable type and Ferrite

Abbreviation	Cable type and Ferrite
a	Enclosed cable
b	Available accessory (exclusive cable)
c	Commercially available cable (with no designation)
d	Commercially available cable (The selection and mounting procedure of the cable is designated in the instruction manual).
e	Fixed cable
f	Enclosed Ferrite (Setting up method of the ferrite is designated in the instruction manual.)
g	Commercially available ferrite. (The selection and setting up method of the ferrite is designated in the instruction manual.)
h	Fixed Ferrite (Already fixed)

(continued)

2.5.7 Block diagram of the Equipment Under Test (EUT) :

**Drawing:**

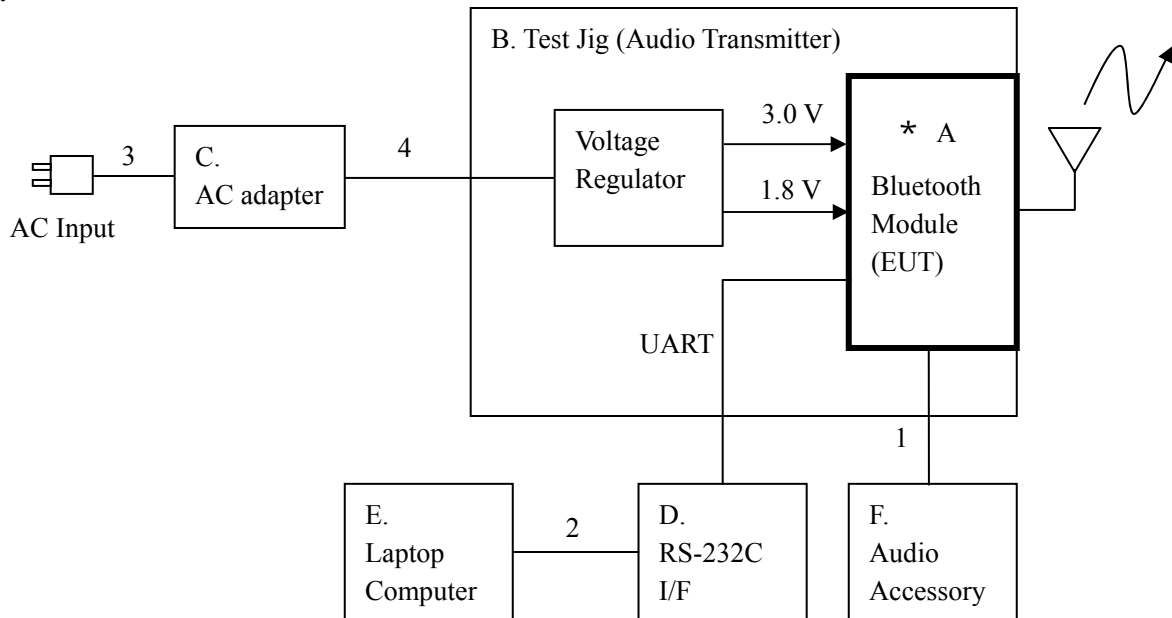

(continued)

## 2.6 Environmental Conditions

### Hopping Characteristics

Carrier Frequency Separation test effort was performed on September 27, 2011.

Temperature:	22	deg. C
Humidity:	45	%
Barometer:	99.7	kPa

Number of Hopping Frequencies test effort was performed on September 28, 2011.

Temperature:	23	deg. C
Humidity:	45	%
Barometer:	100.2	kPa

Average Time of Occupancy test effort was performed on September 29, 2011.

Temperature:	22	deg. C
Humidity:	48	%
Barometer:	99.8	kPa

20dB Bandwidth test effort was performed on September 27, 2011.

Temperature:	22	deg. C
Humidity:	45	%
Barometer:	99.7	kPa

Peak Transmitter Output Power test effort was performed on September 29, 2011.

Temperature:	22	deg. C
Humidity:	48	%
Barometer:	99.8	kPa

Antenna Conducted Spurious Emissions test effort was performed on October 12, 2011.

Temperature:	22	deg. C
Humidity:	67	%
Barometer:	100.4	kPa

(continued)

AC Power Line Conducted Emission of Transmitter test effort was performed on October 4, 2011.

Temperature:	22	deg. C
Humidity:	49	%
Barometer:	99.2	kPa

Radiated Emission of Transmitter (Spurious and Harmonics) test effort was performed on  
October 13, 2011.

Temperature:	22	deg. C
Humidity:	58	%
Barometer:	100.3	kPa

Band Edge test effort was performed on November 11, 2011.

Temperature:	20	deg. C
Humidity:	67	%
Barometer:	100.8	kPa

### 3.0 TEST SITE DESCRIPTION

This testing was performed at:

Name of Test Site: Panasonic EMC Standard Site

Address: Yashiro Sasayama-City, Hyogo 669-2356  
Japan

Registration/Accreditation: This test site has been accredited by NVLAP.  
NVLAP Lab Code: 100428-0  
Effective through: December 31, 2011

**4.0 TEST INSTRUMENTATION****4.1 Table 4-1**

Test equipment list used to perform the AC Power Line Conducted Emission of Transmitter in the No.1 shield room.

No.	Device	Model No.	Serial. No.	Reg. No.	Frequency Range	Last Cal.	Next Cal.
01	Panasonic EMC Standard Site No.1 Shield Room	None	No.1	NVLAP Lab Code: 100428-0	9kHz-300MHz	July 2011 (Maintenance)	October 2011 (Maintenance)
02	Spe. Ana. & Test Receiver	Rohde & Schwarz ESCI	100048	770	9kHz-3GHz	March 2011	March 2012
03	LISN for EUT	Kyoritsu Denshi KNW 407	8-639-2	049	150kHz-30MHz	October 2010	October 2011
04	Attenuator for LISN (03)	HUBER+SUHNER 6910.01.A	N/A	049-2	150kHz-30MHz	October 2010	October 2011
05	Cable S1-01	HUBER+SUHNER RG 223/U	None	829-1	9kHz-1000MHz	April 2011	April 2012
06	Cable S1-02	HUBER+SUHNER RG 223/U	None	829-2	9kHz-1000MHz	April 2011	April 2012

**4.2 Table 4-2**

Test equipment list used to perform the Radiated Emission of Transmitter (Spurious and Harmonics)  
(Below 1GHz) in the OATS No.1.

No.	Device	Model No.	Serial. No.	Reg. No.	Frequency Range	Last Cal.	Next Cal.
01	Panasonic EMC Standard Site OATS No.1	3m 10m	None	NVLAP Lab Code 100428-0	30MHz-1GHz	July 2011 (Maintenance)	October 2011 (Maintenance)
02	EMI Test Receiver	Rohde & Schwarz ESCS	100365	675	9kHz-2750MHz	March 2011	March 2012
03	Spectrum Analyzer	ADVANTEST R3365	35550049	322	100Hz-8GHz	March 2011	March 2012
04	Biconical Antenna	Schwarzbeck VHA9103B & BBA9106	9103-1847	510	30MHz-300MHz	July 2011	July 2012
05	Logperiodic Antenna	Schwarzbeck UHALP9108A	9108-0313	507-1	300MHz-1GHz	July 2011	July 2012
06	Amplifier	Hewlett Packard 8447D	2944A08559	397	100kHz-1.3GHz	November 2010	November 2011
07	Cable O1-01	Fujikura 10D-2W	None	834-1	9kHz-1GHz	August 2011	August 2012
08	Cable O1-02	Fujikura 10D-2W	None	834-2	9kHz-1GHz	August 2011	August 2012
09	Loop Antenna	EMCO 6502	2123	176	9k-30MHz	May 2011	May 2012

**4.3 Table 4-3**

Test equipment list used to perform the Radiated Emission of Transmitter (Spurious and Harmonics) (Above 1GHz) in the Anechoic Chamber (10m).

No.	Device	Model No.	Serial. No.	Reg. No.	Frequency Range	Last Cal.	Next Cal.
01	Panasonic EMC Standard Site Anechoic Chamber	3m 10m	None	NVLAP Lab Code: 100428-0	30MHz- 26.5GHz	July 2011 (Maintenance)	October 2011 (Maintenance)
02	Spe. Ana. & Test Receiver	Rohde & Schwarz ESI26	835336/006	526	9kHz-26.5GHz	January 2011	January 2012
03	Spectrum Analyzer	ADVANTEST R3132	140900614	677	9kHz-3GHz	November 2011	November 2012
04	Horn Antenna	EMCO 3115	9801-5390	457	1GHz-18GHz	November 2010	November 2011
05	Pre Amplifier	Hewlett Packard 8449B	3008A01050	450	1GHz-18GHz	October 2010	October 2011
06	Cable D	HUBER+SUHNER SUCOFLEX/104	85878/4	386	1GHz-26.5GHz	August 2011	August 2012
07	Cable N	HUBER+SUHNER SUCOFLEX/104	152646/4	524-2	1GHz-26.5GHz	August 2011	August 2012
08	Pyramidal Horn Antenna	EMCO 3160-09	1256	542-9	18GHz - 26.5GHz	August 2011	August 2012

**4.4 Table 4-4**

Test equipment list used to perform the Hopping Characteristics and 20dB Bandwidth in the Test room.

No.	Device	Model No.	Serial. No.	Reg. No.	Frequency Range	Last Cal.	Next Cal.
01	Panasonic EMC Standard Site Test Room	-	None	NVLAP Lab Code: 100428-0		-	-
02	Spectrum Analyzer	ADVANTEST R3132	140900614	677	9kHz-3GHz	November 2011	November 2012
03	Attenuator (20dB)	Agilent 8493C	76984	813	DC - 26.5GHz	August 2011	August 2012

**4.5 Table 4-5**

Test equipment list used to perform the Peak Transmitter Output Power in the Test room.

No.	Device	Model No.	Serial. No.	Reg. No.	Frequency Range	Last Cal.	Next Cal.
01	Panasonic EMC Standard Site Test Room	-	None	NVLAP Lab Code: 100428-0		-	-
02	Spectrum Analyzer	ADVANTEST R3132	140900614	677	9kHz-3GHz	November 2011	November 2012
03	Single Channel Power Meter	Agilent Technologies N1911A	MY50000697	832		April 2011	April 2012
04	Wideband Power Sensor	Agilent Technologies N1921A	MY51070021	833		April 2011	April 2012
05	Attenuator (20dB)	Agilent 8493C	76984	813	DC – 26.5GHz	August 2011	August 2012

**4.6 Table 4-6**

Test equipment list used to perform the Antenna Conducted Spurious Emission in the Test room.

No.	Device	Model No.	Serial. No.	Reg. No.	Frequency Range	Last Cal.	Next Cal.
01	Panasonic EMC Standard Site Test Room	-	None	NVLAP Lab Code: 100428-0		-	-
02	Spectrum Analyzer	ADVANTEST R3371A	85060242	539	100Hz-26.5GHz	February 2011	February 2012
03	Attenuator (20dB)	Agilent 8493C	76984	813	DC – 26.5GHz	August 2011	August 2012

## 5.0 TEST EUT SETUP AND CONFIGURATIONS

### 5.1 Technical Requirements

#### 5.1.1 Hopping Characteristics

##### 5.1.1.1 Carrier Frequency Separation

FCC Section 15.247(a)(1)

The Carrier Frequency Separation was measured with a spectrum analyzer connected to the antenna port. (RBW=30kHz, VBW=100kHz)

##### 5.1.1.2 Number of Hopping Frequencies

FCC Section 15.247(a)(1)(iii)

The Number of Hopping Frequencies was measured with a spectrum analyzer connected to the antenna port. (RBW=300kHz, VBW=1MHz)

##### 5.1.1.3 Average Time of Occupancy

FCC Section 15.247(a)(1)(iii)

The Average Time of Occupancy was measured with a spectrum analyzer connected to the antenna port. (RBW=1MHz, VBW=3MHz)

#### 5.1.2 20dB Bandwidth

FCC Section 15.247(a)(1)

The 20dB Bandwidth was measured with a spectrum analyzer connected to the antenna port. (RBW=30kHz, VBW=100kHz)

#### 5.1.3 Peak Transmitter Output Power

FCC Section 15.247(b)(1)

The 20dB Bandwidth was measured with a spectrum analyzer connected to the antenna port. (RBW=3MHz, VBW=3MHz)

#### 5.1.4 Antenna Conducted Spurious Emissions

FCC Section 15.247(d)

The Antenna Conducted Spurious Emissions was measured with a spectrum analyzer connected to the antenna port.

In any 100kHz bandwidth outside the frequency band in which the spread spectrum intentional radiator is operating, the radio frequency power that is produced by the intentional radiator must be 20dB below that in the 100kHz bandwidth within the band that contains the highest level of the desired power.

In the frequency range below 30MHz, RBW was narrowed to separate the noise contents. Then, wide-band noise near the limit was checked separately, however the noise was not detected as shown in the chart.

(150kHz-30MHz: RBW=10kHz, VBW=30kHz,

30MHz-25GHz: RBW=100kHz, VBW=100kHz)

5.1.5 AC Power Line Conducted Emission of Transmitter

FCC Section 15.207

The measurements of the conducted emissions (interference voltage) at the mains ports were performed in a shielded enclosure with peripherals placed on a nonconductive table, 0.8m high over a metal floor.

The EUT was located more than 0.4m away from the shielded enclosure wall and was plugged into the LISN.

Pre-check: AC power line conducted emission levels (Peak value) were measured by means of receiver to identify the frequency of the emission that had the highest amplitude relative to the limit by operating the EUT in a range of typical modes of operation .

Final measurement: Emission levels (AV and QP value) were measured by means of the test receiver referring the result of Precheck. EUT operation mode was selected for maximum emission.

Maximized emission levels were recorded.

(Parameters for precheck spectra:

9kHz-150kHz: RBW=200Hz, VBW=500Hz, 150kHz-30MHz: RBW=9kHz, VBW=30kHz.)

Software for the measurement: PTT Company Limited EMI96 Rev. E26

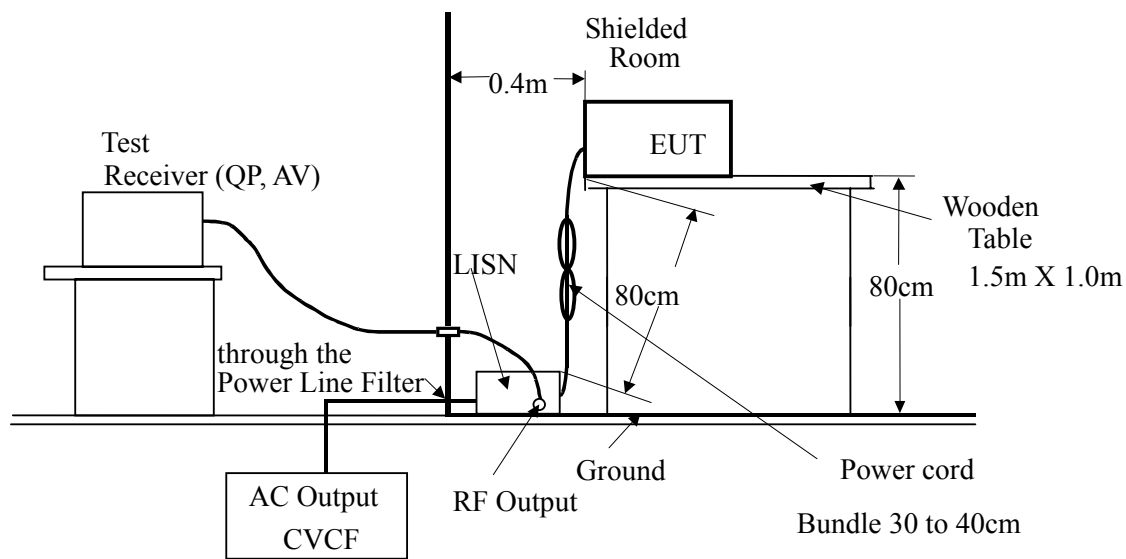

5.1.6 Radiated Emission of Transmitter (Spurious and Harmonics, Band Edge)  
FCC Section 15.205, 15.209 and 15.247(d)  
Radiated emissions must comply with the limits specified in FCC 15.209(a).

Test procedure: ANSI C63.4-2003

The EUT was placed on a nonconductive turntable 0.8m above the ground plane. Before final measurements of radiated emissions were performed, the EUT was scanned to determine its emission spectrum profile. The physical arrangement of the test system and the EUT orientation (X, Y, Z) were varied in order to ensure that maximum emission amplitudes were attained.

The spectrum was examined from 9kHz to 25GHz. Final radiated emission measurements were made at 3m distance.

For frequencies between 9kHz and 30MHz, measurements were performed with a loop antenna. At each frequency selected for final measurement, the EUT was rotated 360° and the measuring loop antenna was rotated around its vertical axis in order to determine the emission's maximum level.

For frequencies between 30MHz and 1GHz, measurements were performed with a Biconical and Logperiodic antenna.

For frequencies between 1GHz and 25GHz, measurements were performed with a Horn antenna.

At each frequency where a spurious emission was found, the EUT was rotated 360° and the antenna was raised and lowered from 1 to 4m in order to determine the emission's maximum level. Measurements were taken using both horizontal and vertical antenna polarizations.

Pre-check: Radiated emission levels (Peak value) which have small margin for the regulation were measured by means of spectrum analyzer changing Antenna movement (1-4m) and table rotation (0-360degree).

Final measurements were made with a receiver operating in the CISPR quasi-peak detection mode for frequencies up to 1GHz.

For frequencies between 150kHz and 30MHz, the receiver's 6 dB bandwidth was set to 9kHz. For frequencies between 30MHz and 1GHz, the receiver's 6 dB bandwidth was set to 120kHz. For frequencies between 1GHz and 25GHz, measurements were made with a spectrum analyzer with a resolution bandwidth set to 1MHz and a video bandwidth set to 1MHz for peak and to 10Hz for average.

The highest emission amplitudes relative to the appropriate limit were recorded in this report. Emissions other than those mentioned are small or not detectable.

(Parameters for precheck spectra:

9kHz-150kHz: RBW=200Hz, VBW=500Hz, 150kHz-30MHz: RBW=9kHz, VBW=30kHz,  
30MHz-1000MHz: RBW=100kHz, VBW=100kHz, 1GHz-25GHz: RBW=1MHz, VBW=1MHz)

Software for the measurement: PTT EMI96 Rev. E26

From 9kHz to 30MHz Measurement layout.

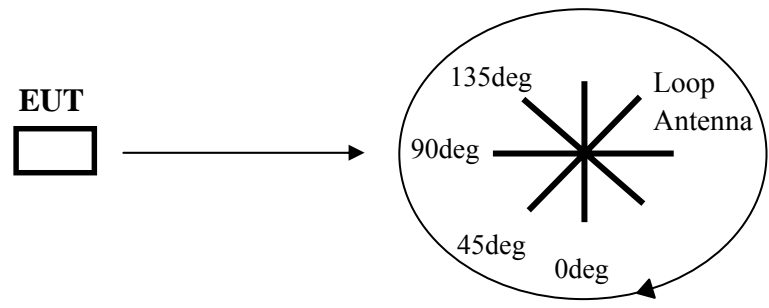
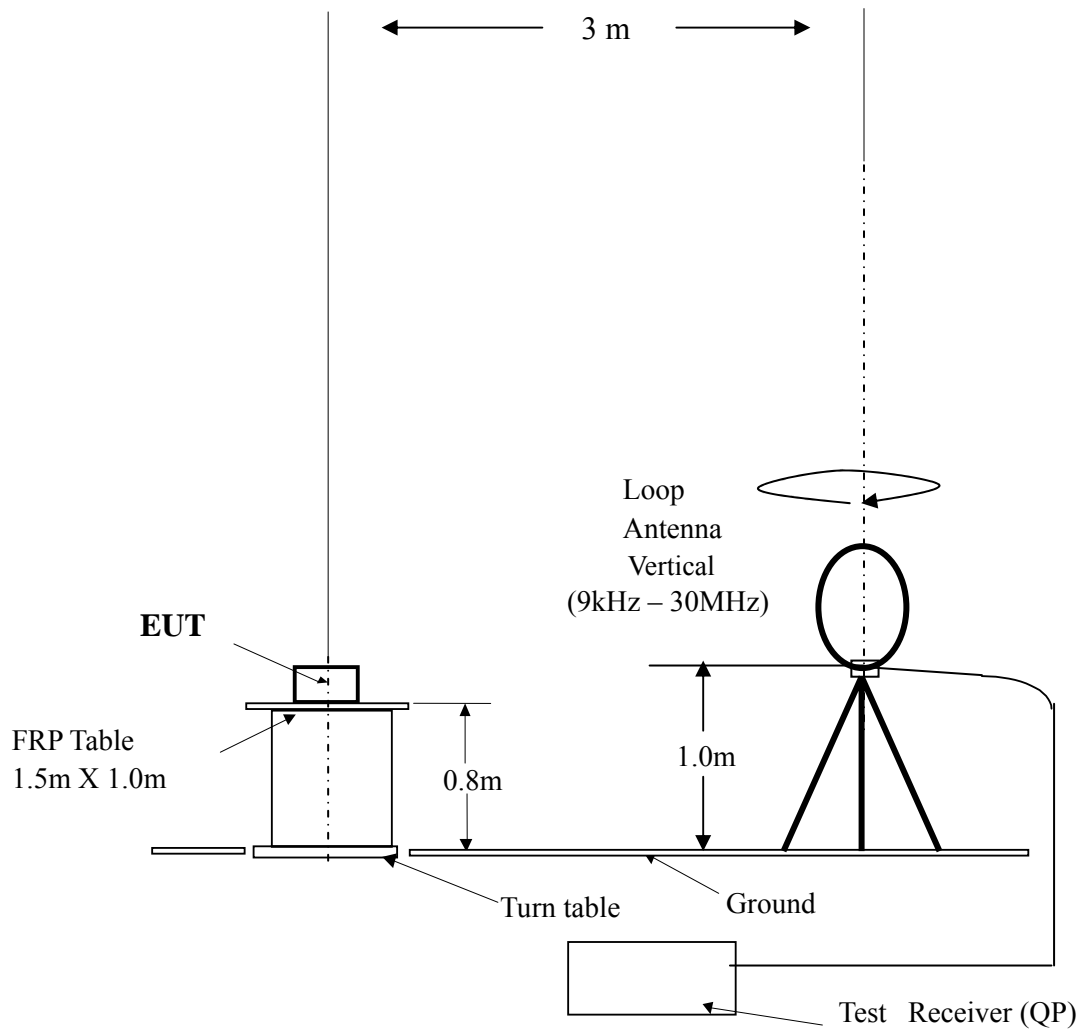

(Continued)

From 30MHz to 1GHz Measurement layout.

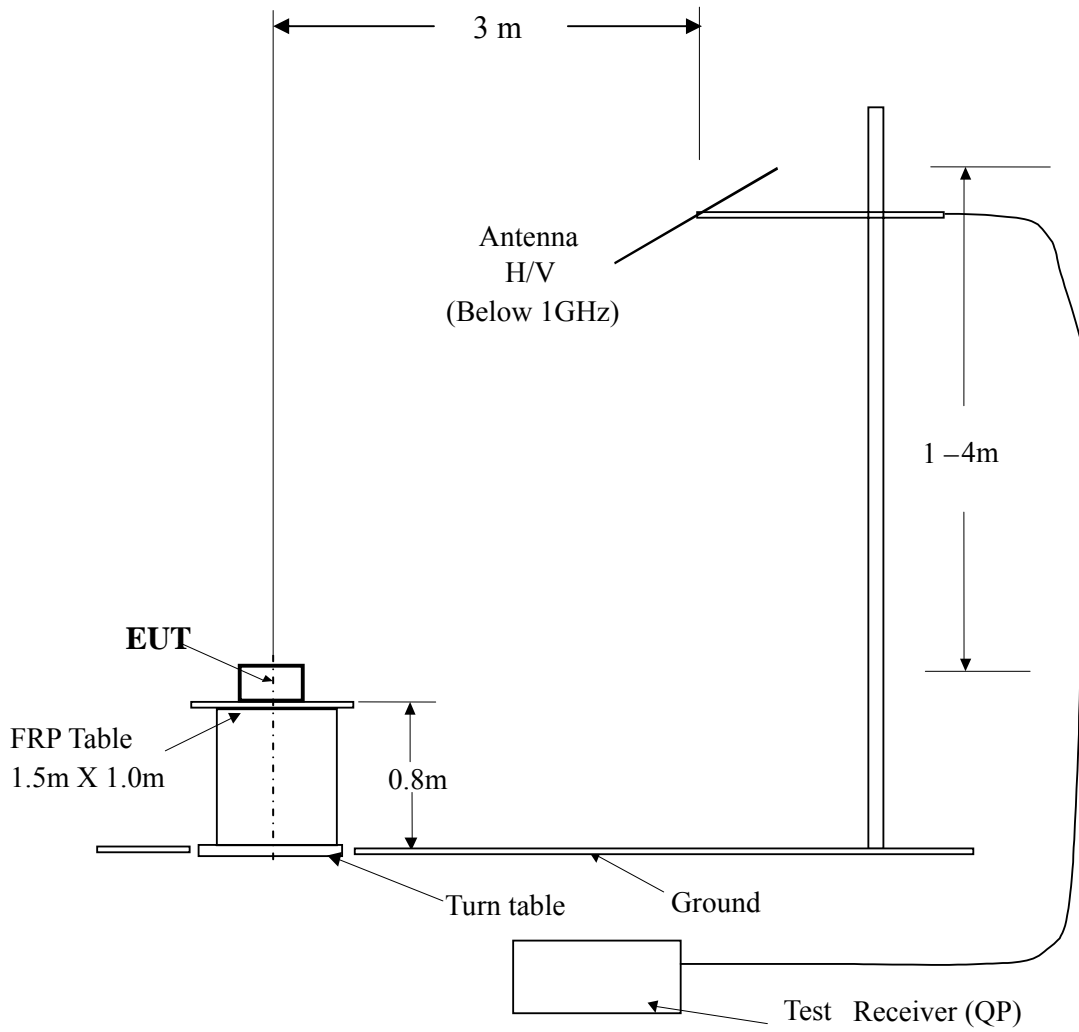

(Continued)

From 1GHz to 25GHz Measurement layout.

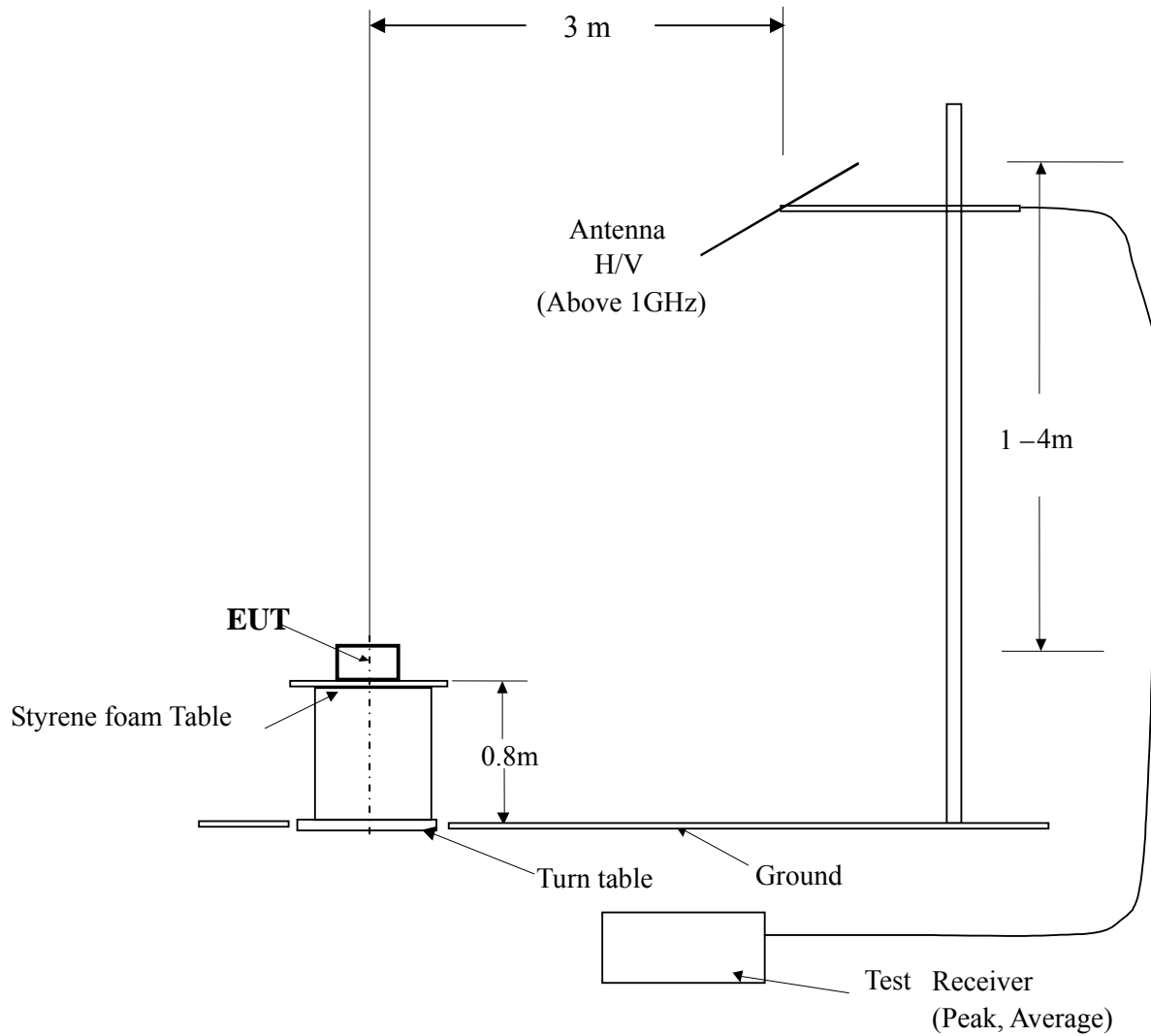

### 5.1.7 Band Edge

FCC Section 15.205, 15.209 and 15.247(d)  
Band edge level is below the limits of FCC 15.209.  
Refer to the data of Radiated emission.

## **6.0 TEST RESULTS**

### **6.1 Hopping Characteristics**

Carrier Frequency Separation, Number of Hopping Frequencies and Average Time of Occupancy  
Results of the tests please see attachment A.

### **6.2 20dB Bandwidth**

Results of the tests please see attachment A.

### **6.3 Peak Transmitter Output Power**

Results of the tests please see attachment A.

### **6.4 Antenna Conducted Spurious Emissions**

Results of the tests please see attachment A.

### **6.5 AC Power Line Conducted Emission of Transmitter**

Results of the tests please see attachment A.

### **6.6 9k - 25G Radiated Emission of Transmitter (Spurious and Harmonics)**

Results of the tests please see attachment A.

### **6.7 Band Edge (Radiated Test)**

Results of the tests please see attachment A.