

Technical Specification

EXHIBIT # : 4-1  
FCC ID : ACJ927130TX  
OUR REF. : MKES99-F023  
MODEL NO. : PV-C2080

Power Source : AC 120 V, 60 Hz

Power Consumption : 110W

Audio input : Max. +8 dBV

Operating Temperature : 5 - 40

Operating Humidity : 10 % - 75 %

Description of FM Transmitter

EXHIBIT # : 4-2  
FCC ID : ACJ927130TX  
OUR REF. : MKES99-F023  
MODEL NO. : PV-C2080

Performance Explanation of FM Transmitter

Each signal of Tuner, Line-In and Playback passes through the limiting circuit and is converted to Stereo Composite signal by the Stereo Process circuit. Stereo Composite signal is FM-modulated by the Oscillation Process circuit, then passes through the BPF and radiate through the antenna.

Band width is limited by the limiting circuit for the Base Band Audio.

Spurious is attenuated by the BPF circuit.

Frequency of carrier is determined by L, C, and D in oscillator circuit. Consequently the frequency stability is determined by L, C, and D which is +/-250 kHz.

Antenna is permanently constructed by the foil-pattern on the main PCB.

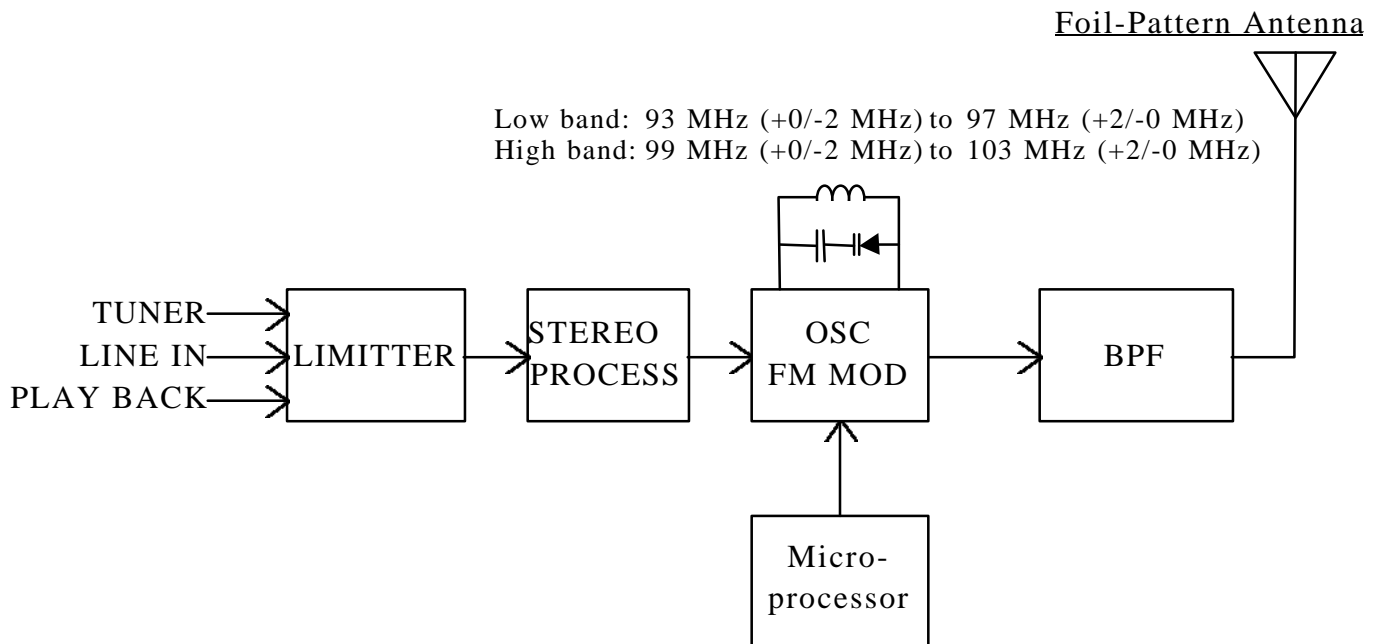
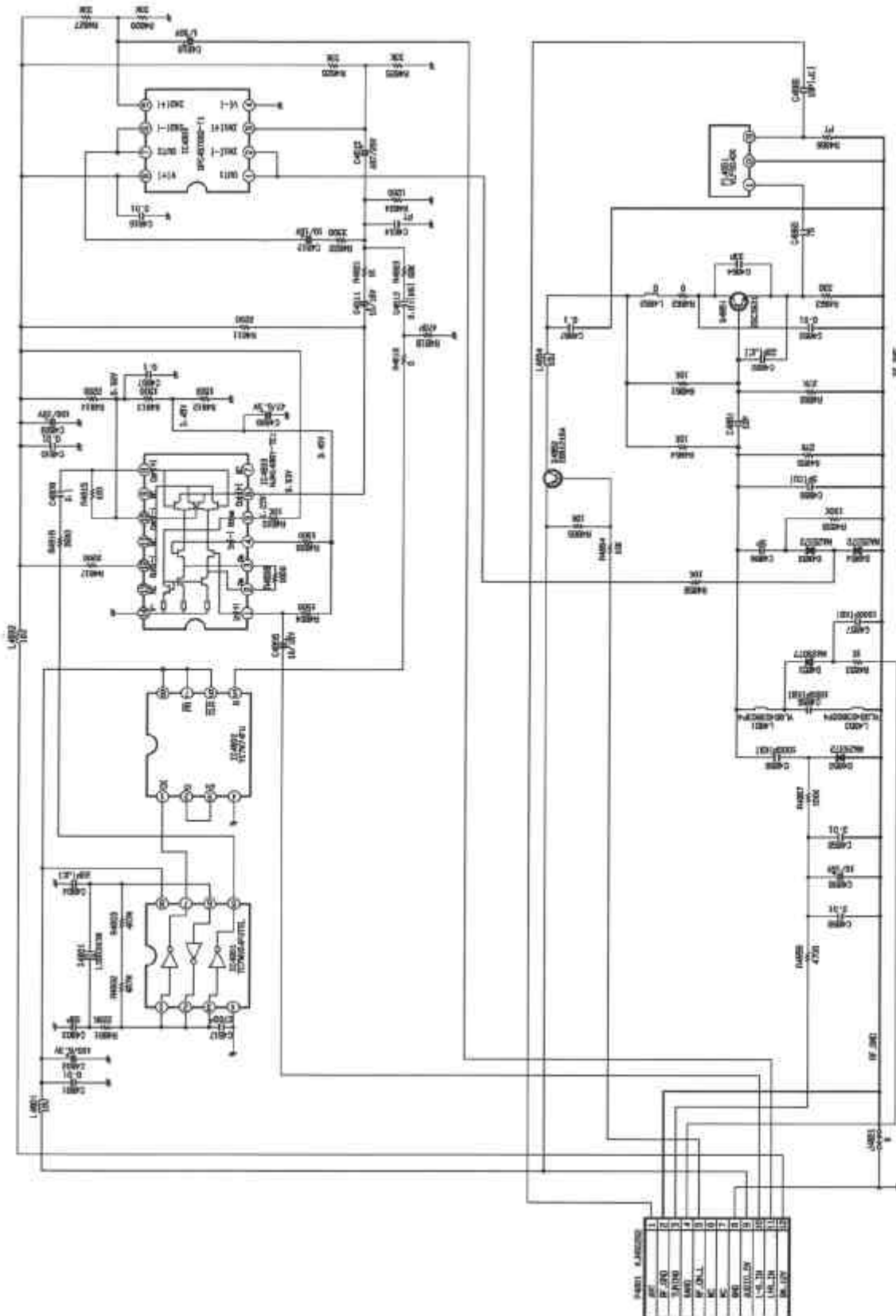

EXHIBIT # : 4-3  
 FCC ID : ACJ927130TX  
 OUR REF. : MKES99-F023  
 MODEL NO. : PV-C2080



# FM TRANSMITTER

EXHIBIT # : 5  
 FCC ID : ACJ927130TX  
 OUR REF. : MKES99-F023  
 MODEL NO. : PV-C2080

Block Diagram

