

EA95574

Mkes99-F020

Description of Digital Device

EXHIBIT # : 4-1
FCC ID : ACJ927127K
OUR REF. : MKES99-F020
MODEL NO. : PV-L850D

Page 1/2

Technical Specification

Power Source : DC 6V
Power Consumption : 8.5W
Video Recording System : EIA Standard (525 lines, 60 fields)
NTSC color signal
Frequency generated or used : 10 Hz - 28.6 MHz
Operating Temperature : 0°C - 40°C
Operating Humidity : 10 % - 75 %

Richard Mullen

Richard Mullen
Matsushita Electric Corp. of America
One Panasonic Way, Panazip 4B-8
Secaucus, NJ 07094

Device Operation Description

EXHIBIT # : 4-1
FCC ID : ACJ927127K
OUR REF. : MKES99-F020
MODEL NO. : PV-L850D
Page 2/2

Performance Explanation of Video Camera

Light on CCD through the lens is converted into the electric analog signal, and it goes to the Camera Process. Through the Camera Process, such analog signal is converted into the digital signal via built-in A/D Converter. And its digital signal is converted into NTSC signal, then it is converted again into analog signal to VCR Process. It is output through VCR Process to TV Monitor.

The route of signal from Camcorder to PC: CCD Output signal which was input to Camera Process is A/D converted. It is divided prior to NTSC Process and is led, via digital output of Camera Process, to Camera CPU. Then it is converted in the CPU into RS232C signal and output to RS232C Driver. It is voltage-converted by RS232C Driver and goes to PC through RS232C Cable. Like, Control signal and Frozen Image Picture goes from PC to Camcorder. And the image data through Camera CPU is stored in the CF Card. On the other hand, the data stored in the CF Card is output on the Monitor TV through the same BUS line via Camera CPU, Camera Process and VCR Process. This CF Card is a removable data storage media. Through this data transmission system, playback picture data cannot be transmitted because this system is just for transmitting the image data interactively between Camera Signal Process IC and PC.

Through this data transmission system, playback picture data cannot be transmitted because this system is just for transmitting the image data interactively between Camera Signal Process IC and PC.

MOVIE BLOCK DIAGRAM

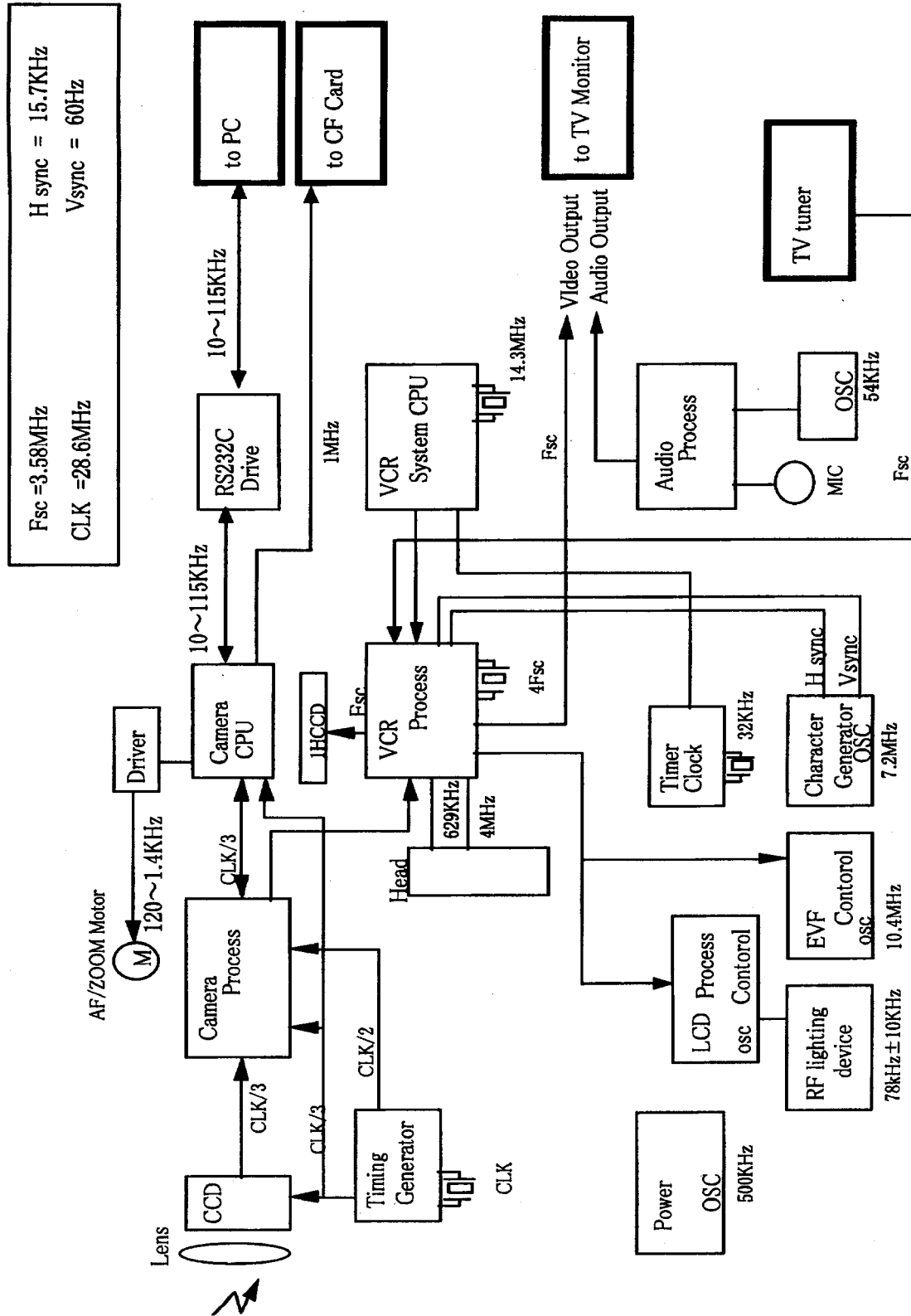

EA95574

EXHIBIT # : 4-2
 FCC ID : ACJ927127K
 OUR REF. : MKES99-F020
 MODEL NO. : PV-L850D

EXHIBIT # : 4-2
FCC ID : ACJ927127K
OUR REF. : MKES99-F020
MODEL NO. : PV-L850D

Page 2/2

List of Frequency

CLOCK of Video Camera

CIRCUIT Name	CLOCK
Timing Generator	28.6 MHz
CCD	14.3 MHz
Camera Process	14.3 MHz
Camera I/F	14.3 MHz
VCR Process	14.3 MHz
CYL Head	629 KHz - 4 MHz
RS-232C	10 - 115 KHz
CF Card	1 MHz
Power	500 KHz
Timer Clock	32.0 KHz
Character Generator OSC	7.2 MHz
VCR System CPU	14.3 MHz
EVF Process (PLL)	10.38 MHz