

# ZB-01 LR-WPAN Module

## P/N PAN802154\_\_\_\_\_

### Application Notes

# Panasonic

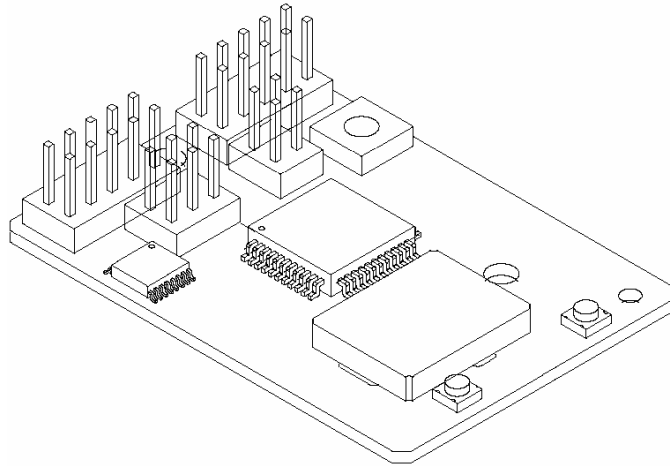

| Rev | Author/Editor | Issue Reason  | Date      | Release Approval |
|-----|---------------|---|-----------|------------------|
| A   | Fox / Nguyen  | Initial release / Revise  | 3-22-2005 | RBNguyen         |
| A1  | Trueman       | Revise  | 3-29-2005 | RBNguyen         |
| A2  | Cardenas      | Connector Nomenclature Change.<br>(Use Rev.A1 for earlier Engineering Samples with Rev. 5 or earlier artwork) | 7-06-2005 | RBNguyen         |
| A3  | Cardenas      | Add FCC restrictions and mechanical drawing   | 9-22-05   |                  |
|     |               |   |           |                  |

Table of content

|          |  |           |
|----------|--|-----------|
| <b>1</b> | <b>INTRODUCTION .....</b>  | <b>3</b>  |
| 1.1      | Regulatory information.....  | 3         |
| 1.2      | Abbreviations and Acronyms .....   | 3         |
| <b>2</b> | <b>LR/WPAN PAN802154HAR FEATURES, AND COMPONENT DESCRIPTION .....</b>                      | <b>5</b>  |
| 2.1      | PAN802154 Image, Component Layout and Block Diagram .....                                  | 6         |
| 2.2      | Component and Descriptions.....  | 7         |
| 2.2.1    | J3: General Purpose Header.....  | 7         |
| 2.2.2    | J2: Serial Port Header .....   | 7         |
| 2.2.3    | J4: Power/GND Header .....   | 9         |
| 2.2.4    | J1: BDM Programming header/Debugger .....  | 9         |
| 2.2.5    | SW1: General Purpose Switch.....   | 10        |
| 2.2.6    | D1: LED .....  | 10        |
| 2.2.7    | U1: MCU .....  | 10        |
| 2.2.8    | U3: RF IC .....  | 10        |
| 2.3      | Mechanical Dimensions.....   | 10        |
| <b>3</b> | <b>APPLICABLE SW COMPONENTS .....</b>  | <b>12</b> |
| 3.1      | SW Architecture .....  | 12        |
| 3.1.1    | Different Possible Applications with Available Software Components .....                   | 12        |
| 3.2      | Bootloader .....   | 12        |
| 3.3      | Required SW Tools.....   | 13        |
| 3.4      | Freescale™ ZigBee Development Platform.....  | 13        |
| 3.5      | Special mapping for the PAN802154 Module in Metrowerks Code Warrior Development Tool. .... | 13        |
| 3.5.1    | Compiling with a Z-Stack Project .....   | 14        |
| 3.5.2    | Compiling without using the Z-Stack .....  | 14        |
| 3.6      | Differences between the Panasonic PAN802154 and the Freescale SARD Development Board ..... | 15        |
| 3.6.1    | Switch.....  | 15        |
| 3.6.2    | LED .....  | 15        |
| 3.6.3    | RS-232 Interface.....  | 16        |
| 3.6.4    | Editing SARD Header File for the Panasonic Module .....                                    | 16        |
| 3.7      | How to load a SW program into the Panasonic Module .....                                   | 20        |
| <b>4</b> | <b>FREQUENTLY ASKED QUESTIONS .....</b>  | <b>24</b> |
| <b>5</b> | <b>REFERENCE DOCUMENTS .....</b>   | <b>27</b> |
|          | <b>APPENDIX 1 FCC AND CANADA CERTIFICATIONS.....</b>                                       | <b>30</b> |
|          | Instruction to the user .....  | 30        |
|          | Integration in OEM products: VERY IMPORTANT! .....   | 30        |
|          | <b>APPENDIX 2 ORDERING INFORMATION .....</b>   | <b>32</b> |

## 1 INTRODUCTION

The purpose of this document is to present a method for designing products using the Panasonic Low Rate / Low Power Wireless Area Network Communication Module Part Number PAN802154HAR00 and familiarize engineers with application details.

A Frequently Asked Questions (FAQ's) section is also provided for engineering quick references.

### Panasonic ZB-01 LR/WPAN PAN802154HAR Module

Panasonic's LR/WPAN PAN802154 Module is a Low Rate / Low Power communication device based upon the Freescale™ ZigBee Sensor Application Reference Design (SARD) development platform. It operates in the ISM 2.4 GHz band, and is fully compliant with the IEEE 802.15.4 standard. The PAN802154 is ready to be downloaded with Freescale's 802.15.4 PHY/ MAC layer and ZigBee protocol layer.

The PAN802154 uses the Freescale's 802.15.4 transceiver (MC13193), micro controller (GT60) and is licensed to use all released Freescale ZigBee Protocol stack layer software. Further, the PAN802154 has an on-board RS-232 interface IC and two on-board printed antennas that are etched on both sides of the board for optimum RF sensitivity. The whole RF section that encompasses U3 and all passive components and baluns are shielded to prevent RF leakage and further improve RF performance.

The PAN802154 is tested to fully comply with current FCC requirements for 2.4 GHz ISM band application. This allows the customer to complete and bring the end product to the market much quicker. The application profile or program can be developed with in-house SW staff or with any third-party SW development contractor including Panasonic.

#### 1.1 Regulatory information

Refer to **Appendix A** for regulatory information

FCC ID: Pending

Canada: Pending

#### 1.2 Abbreviations and Acronyms

|                |  |
|----------------|--|
| <b>MCU</b>     | Micro-controller Unit                                |
| <b>FAQ</b>     | Frequently Asked Questions                           |
| <b>LR/WPAN</b> | Low Rate / Low Power Wireless Personal Area Network. |
| <b>Jx</b>      | Header Connector Number                              |
| <b>SW1</b>     | General Purpose Switch 1                             |
| <b>BDM</b>     | Background Debugger Module                           |

|                |   |
|----------------|---|
| <b>SARD</b>    | Sensor Application Reference Design                   |
| <b>RFD</b>     | Reduced Function Device                               |
| <b>FFD</b>     | Full Function Device                                  |
| <b>MAC</b>     | Media Access Controller                               |
| <b>SMAC</b>    | Simple Media Access Controller                        |
| <b>Z-Stack</b> | Freescale™ ZigBee Protocol Stack                      |
| <b>IEEE</b>    | The Institute of Electrical and Electronics Engineers |

## 2 LR/WPAN PAN802154HAR FEATURES, AND COMPONENT DESCRIPTION

**PAN802154 Module is designed with all Hardware on board and downloadable SW to be configured as a FFD Coordinator / Router or a RFD End Node.**

### **PAN802154 Features**

- Fully supports ZigBee™, 802.15.4, or Simple MAC Application
- 2.4 GHz ISM, ZigBee™
- 16 Channels, 5MHz channel spacing, Full Spectrum Encode and Decode (IEEE Standard 802.15.4); up to 250 Kbps bit rate.
- RS-232 port; 2 Analog Inputs selectable to 10bit A/D Converter; and up to 8 Digital I/O ports on easy to connect header connector
- Background Debug Feature
- 1 Switch and 1 LED for control and monitoring
- Output power: 0dBm typical (1mW)
- RX Sensitivity: -92dBm typical at 1.0% Packet Error Rate.
- Shielded RF Section for improved performance
- On board printed antenna or optional connector for external antenna
- Commercial and Industrial Operating Temperature Range
- Power Supply Range:
  - 2.2VDC to 3.4 VDC without using RS-232 capability
  - 3.0VDC to 3.4 VDC with using RS-232 capability
- DC current:
  - RX/TX: 35mA typical
  - Doze: 80uA typical

**2.1 PAN802154 Image, Component Layout and Block Diagram**

All components are on the front side of the PAN802154. No back- side image is shown here

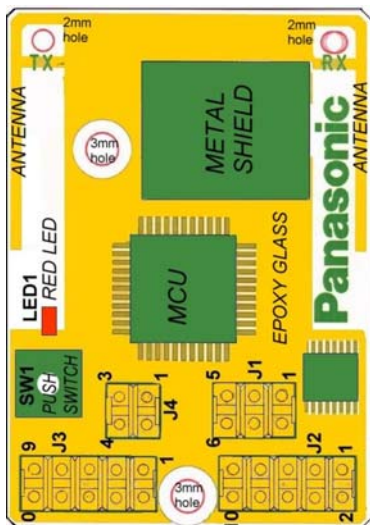
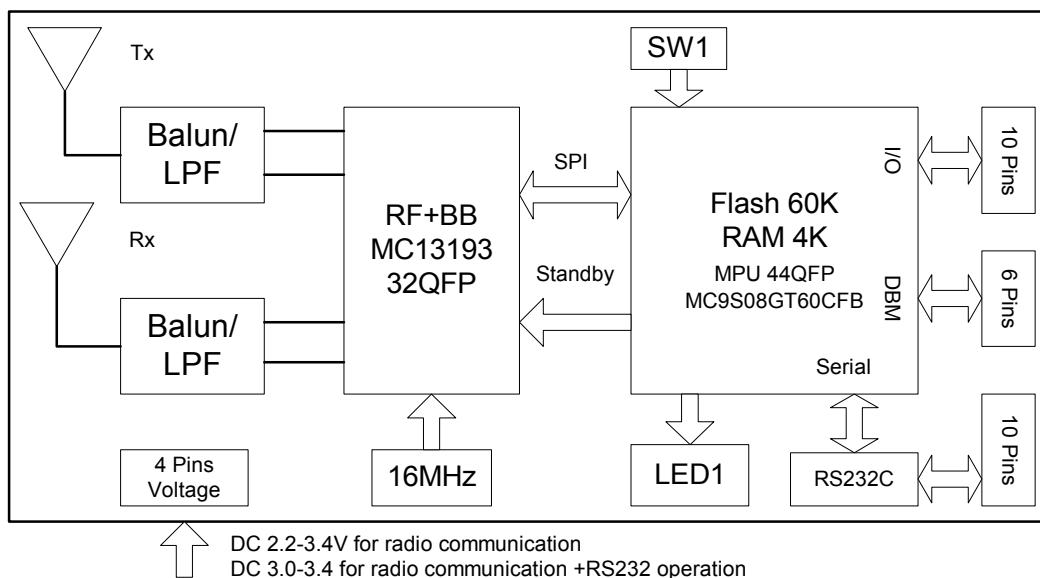

**Figure 1: Module connector location**



**Figure 2: Module picture**

- 1) Connectors J1, J2, J3 & J4 straight 2.54" pitch, Contact material Zn
- 2) Substrate Glass Epoxy t=1.2mm
- 3) Push switch and red LED used as application required
- 4) Metal cover to meet FCC rules
- 5) 3.17mm holes to use 1/8" screw diameter for mounting using non- conductive spacer



**Figure 3: Block Diagram**

## 2.2 Component and Descriptions

### 2.2.1 J3: General Purpose Header

Header J3 is intended to be used as a general purpose I/O header. A power and GND pin are also provided to allow connection to external components.

Use Molex P/N 1544-5810 or 10 pins 0.1" standard female connector as mating receptacle.

| Hdr. Pin # | MCU PORT/PIN Name | Function                                    | Remarks   |
|------------|-------------------|---|---|
| J3-1       | PTA7              | General purpose digital I/O                 | J3-1 through J3-4 Can wake MCU from stop 3 or wait mode. They can detect falling/rising edges and low/high levels when keyboard interrupt is enabled<br><br>Pins J3-5 and J3-6 can detect falling edges or low levels when keyboard interrupt is enabled. |
| J3-2       | PTA6              |   |   |
| J3-3       | PTA5              |   |   |
| J3-4       | PTA4              |   |   |
| J3-5       | PTA0              |   |   |
| J3-6       | PTA1              |   |   |
| J3-7       | VCC               | Digital Power Pin                           | To provide external power to PAN802154 or vice versa.   |
| J3-8       | GND               | GND   |   |
| J3-9       | PTB0              | Analog input or general purpose digital I/O | Connected to MCU Analog-to-digital 10 bit A/D converter, channels 0 and 1   |
| J3-10      | PTB1              |   |   |

**Table 1: J3 Pin out**

### 2.2.2 J2: Serial Port Header

Header J2 is a serial port header for connection to a PC's serial port. The header contains an RS-232 level TX line, an RX line, and GND.

Use Molex P/N 1544-5810 or 10 pins 0.1" standard female connector as mating receptacle.

***It is important to note that although the MCU and the Transceiver radio can work as low as 2.4 VDC, proper operation for RS-232 requires VCC to be greater than 3.0 volts DC.***

| Hdr. Pin # | MODEL WITH RS232 | MODEL WITHOUT RS232 | RS-232 PIN NAME | Function                                | Remarks                                  |
|------------|------------------|---------------------|-----------------|---|--|
| J2-1       | NC               | PTE0/TXD1           | -               | Digital port for control or serial port | MCU's Serial Com Interface data transmit |
| J2-2       | NC               | PTE1/RSD1           | -               | Digital port for control or serial port | MCU's Serial Com Interface data receive  |
| J2-3       | RS232_TX         | NC                  | RS232_TX        | Transmit line for serial port           | RS-232 level transmit signal             |
| J2-4       | NC               | NC                  | -               | NC                                      |  |
| J2-5       | RS232_RX         | NC                  | RS232_RX        | Receive line for serial port            | RS-232 level receive signal              |
| J2-6       | NC               | NC                  | -               | NC                                      |  |
| J2-7       | NC               | PTC6                | -               | Digital port for control                | Shutdown control for RS232 tranceiver    |
| J2-8       | NC               | NC                  | -               | NC                                      |  |
| J2-9       | GND              | GND                 | GND             | Ground                                  |  |
| J2-10      | NC               | VCC                 | -               | NC                                      |  |

Table 2: J2 Pin out

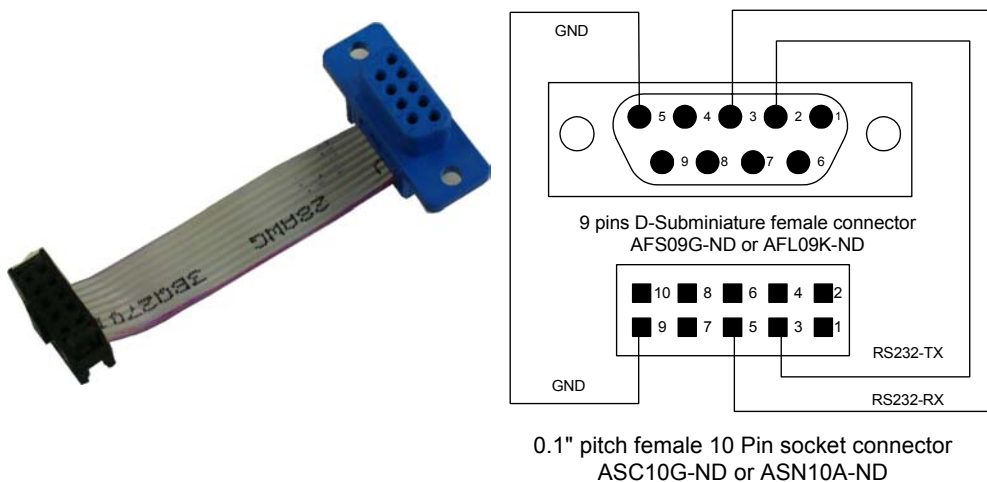

Figure 4: Serial interface cable from PAN802154 to Computer RS232

### 2.2.3 J4: Power/GND Header

Header J4 is the power connector for the PAN802154.

Use Molex P/N 1544-5804 or 4 pins 0.1" (2.54mm) standard female connector as mating receptacle.

| Hdr. Pin # | PIN NAME | Function                                      | Remark   |
|------------|----------|---|--|
| J4-1       | GND      | Ground  |  |
| J4-2       | VCC      | VCC   | Module's Power supply Refer to specification for operating voltage     |
| J4-3       | GND      | Ground  |  |
| J4-4       | AD_REF   | Analog-to-digital converter reference voltage | All analog signals are measured with respect to this reference voltage |

**Table 3: J4 Pin out**

### 2.2.4 J1: BDM Programming header/Debugger

Header J1 provides the connection for the Flash programmer and software debugger.

Use Molex P/N 1544-5806 or 6 pins 0.1" (2.54mm) standard female connector as mating receptacle.

| Hdr. Pin # | PIN NAME  | Function                                       | Remarks   |
|------------|-----------|--|---|
| J1-1       | PTG0/BKG0 | Serial Programming Line or General Purpose I/O | This line controls the loading of new program code to the MCU. Pin has 4.7K pull-up. After code is loaded, acts as digital I/O. |
| J1-2       | GND       | Ground   |   |
| J1-3       | -         | N/C  |   |
| J1-4       | /RESET    | Reset to MCU                                   | Active-low reset  |
| J1-5       | -         | N/C  |   |
| J1-6       | VCC       | Provides power to BDM debugger module          |   |

**Table 4: J1 Pin out**

**2.2.5 SW1: General Purpose Switch**

SW1 is a general-purpose switch that connects to PTA2. Pressing the switch will pull the signal to GND. The internal pull-up for PTA2 must be enabled to use this switch in an application.

**2.2.6 D1: LED**

The LED is connected to PTD0 through a 330-ohm resistor. Setting the PTD0 pin to an output and setting the value high will turn on the LED. Setting the pin low will turn off the LED.

**2.2.7 U1: MCU**

U4 is the Micro-Controller Unit -- Freescale part number: MC9S08GT60CFB. It has an 8-bit microprocessor, 60K byte Flash, 4 K byte RAM, and a 10 bit A/D converter. In addition to its capability to process the 802.15.4 PHY/MAC and protocol stack, it still has plenty of processing power left to run simple, normal sensor/actuator applications.

**2.2.8 U3: RF IC**

U3 is the radio frequency transceiver –Freescale part number: MC13193. This transceiver together with U1 MCU forms a fully compliant IEE 802.15.4 IEEE Standard radio. The whole RF section that encompasses U3, all passive components and baluns are shielded to improve overall RF performance.

**2.3 Mechanical Dimensions**

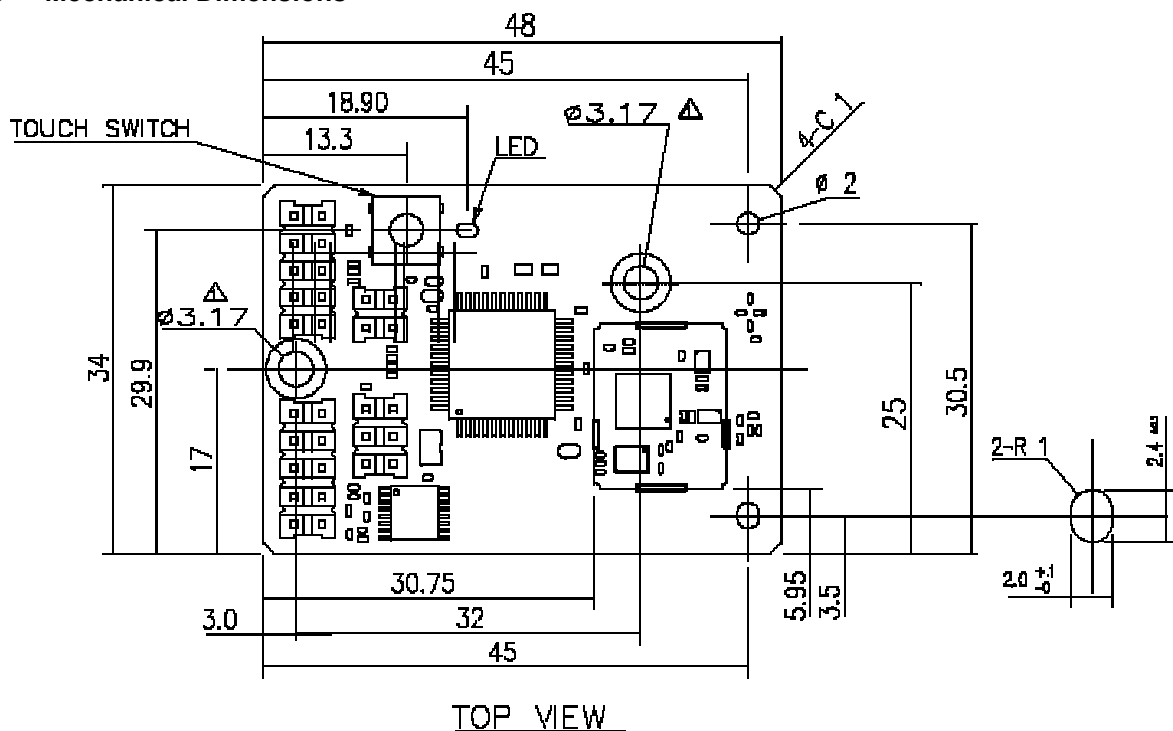

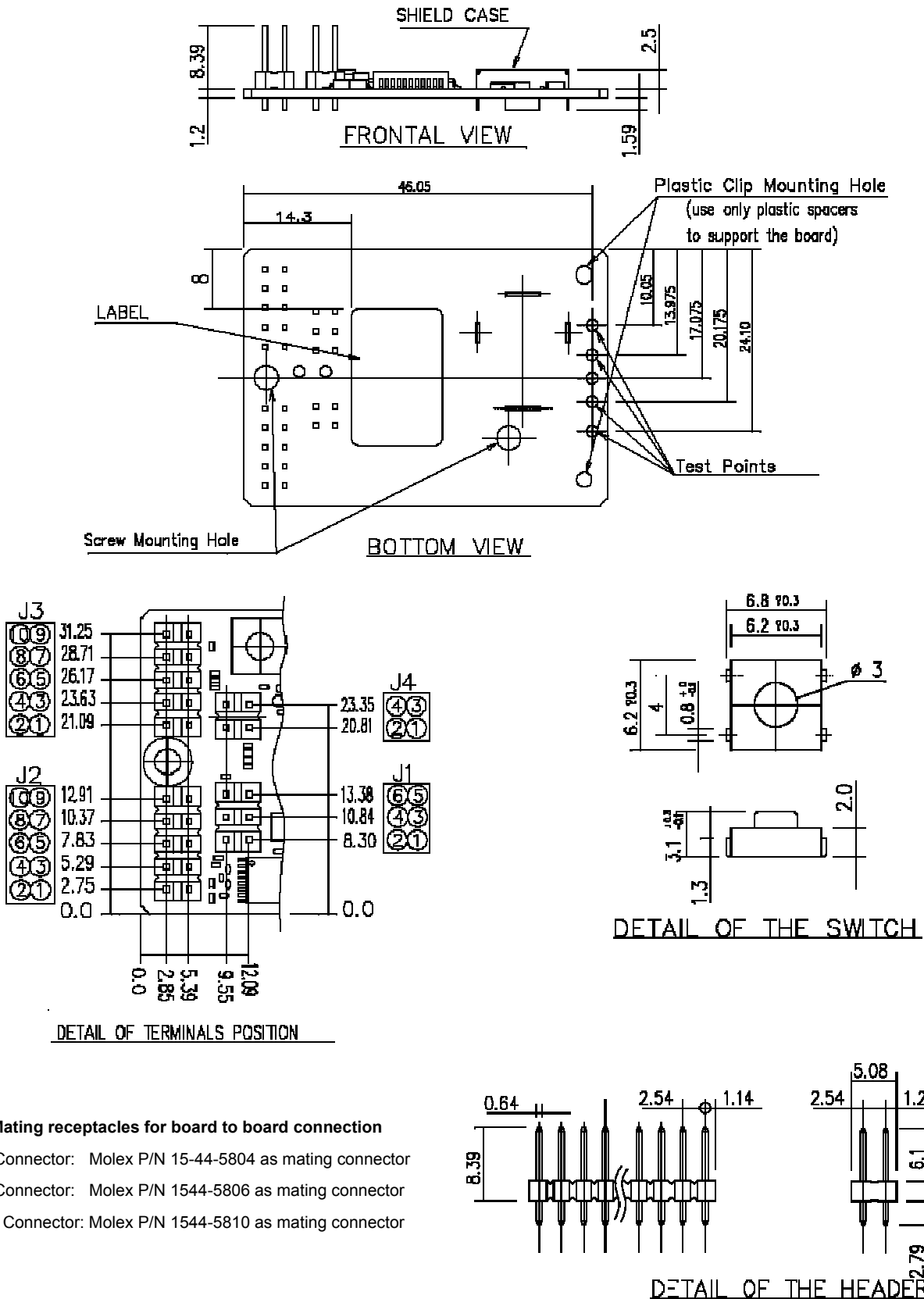

**Mating receptacles for board to board connection**

- 4 Pin Connector: Molex P/N 15-44-5804 as mating connector
- 6 Pin Connector: Molex P/N 1544-5806 as mating connector
- 10 Pin Connector: Molex P/N 1544-5810 as mating connector

**Figure 5: Mechanical drawing**

### 3 APPLICABLE SW COMPONENTS

#### 3.1 SW Architecture

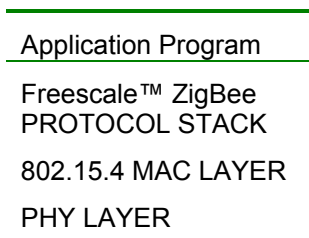

Diagram Three: PAN802154 SW Architecture

The bottom 3 layers may be downloaded from Freescale™ 's website. Only the Application Program or Profile will need to be generated by the system developer. There are many reference code examples available from the Freescale™ website.

Depending on the application, the following Freescale™ SW components may be appropriate:

- a) Freescale Embedded Bootloader
- b) 802.15.4 PHY/MAC
- c) ZigBee Protocol Stack

All of the SW above is downloadable from Freescale website; <http://www.freescale.com/ZigBee>

##### 3.1.1 Different Possible Applications with Available Software Components

The PAN802154 can function with a variety of Freescale-provided software such as:

- a.) SMAC (Simple MAC)
- b.) 802.15.4 MAC
- c.) ZigBee Protocol Stack

Depending on the desired application complexity, the user may choose one of the above SW environments SMAC is the simplest, followed by the 802.15.4 MAC. Using the ZigBee protocol stack on top of the 802.15.4 MAC will be the most complex and allows the end product to meet the ZigBee Alliance standard.

The system user may elect to not use the Freescale provided ZigBee protocol stack and develop a system application based on the 802.15.4 standard protocol only. This could happen with legacy applications that need not be interoperable with the ZigBee community devices.

For even simpler system, the user can even ignore the 802.15.4 MAC and just use the SMAC (Simple MAC), and develop the application program on top of this MAC.

#### 3.2 Bootloader

The PAN802154 comes with only the Bootloader loaded.

**For engineering samples, please start the SW application development process by erasing all contents of the flash (60K bytes) prior to loading any SW components.**

### 3.3 Required SW Tools

You will need the following SW tools to develop an application program/profile.

- 1) Metrowerks Codewarrior Development Studio for HC(S)08 64K C Compiler. Part Number CWS-H08-C64K-CX. (<http://store.metrowerks.com>)
- 2) Freescale™ ZigBee Development tool --- This tool is available from Freescale
- 3) BDM MULTILINK Flash Programming tool ( Software and hardware). This is available from PEMicro in USB or parallel port presentation. ([www.pemicro.com](http://www.pemicro.com))

### 3.4 Freescale™ ZigBee Development Platform

Freescale™ Semiconductor has created several hardware and software development platforms. The Z-Stack and 802.15.4 MAC were created to work with all of these specific hardware platforms.

If you are already familiar with one of the Freescale™ Development Platforms, using the Panasonic Module in your system is very easy as *The Panasonic PAN802154 is most closely resembles the SARD.*

### 3.5 Special mapping for the PAN802154 Module in Metrowerks Code Warrior Development Tool.

Panasonic PAN802154 uses the Freescale GT60 MCU (U1) in conjunction with the MC13193 Transceiver (U3) --- the correct MCU part number must be chosen for the specific device function role for the compiler to generate the correct object code.

There are basically 3 function devices

- a) End Device – (Reduced Function Device - RFD)
- b) Router Device – (Full Function Device - FFD)
- c) Device Coordinator – (Full Function Device - FFD)

***Note that only FFD can communicate with any device. RFD can only communicate with FFD, and not with another RFD.***

Metrowerks Code Warrior Development Studio for HC (S) 08 64K Compiler is the compiler. Libraries and source code projects provided by Freescale™ are compatible with this compiler. The compiler may be found on the Freescale™'s website at [www.freescale.com](http://www.freescale.com). The 64K-compiler upgrade is needed to compile the full ZigBee stack.

### 3.5.1 Compiling with a Z-Stack Project

For compiling with the Z-Stack, the compile flag TARGET\_DIG536\_2 needs to be added to the Codewarrior project settings. There are two ways to do this. If you are working in a Z-Stack project, simply select the GT60 DIG536 target in whichever project is to be compiled (see figure 2 below).

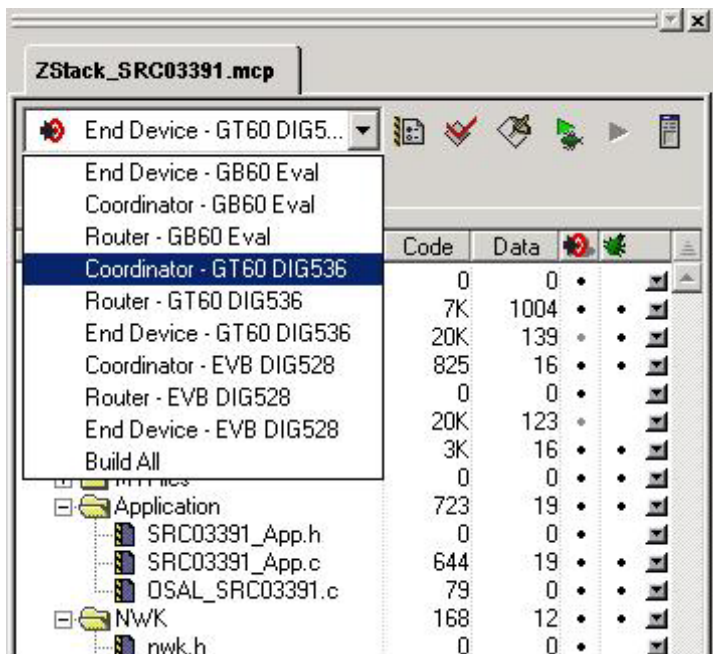

Figure 6: Using pre-defined project setting

### 3.5.2 Compiling without using the Z-Stack

Without using the Z-Stack, one can manually set the project settings compile flag. This is possible by clicking on the project setting button in CodeWarrior and selecting 'Compiler for HC08'. You can then manually add compile flags to the command line arguments (see figure 3 below). Entering ' -DTARGET\_DIG536\_2' accomplishes this mapping.

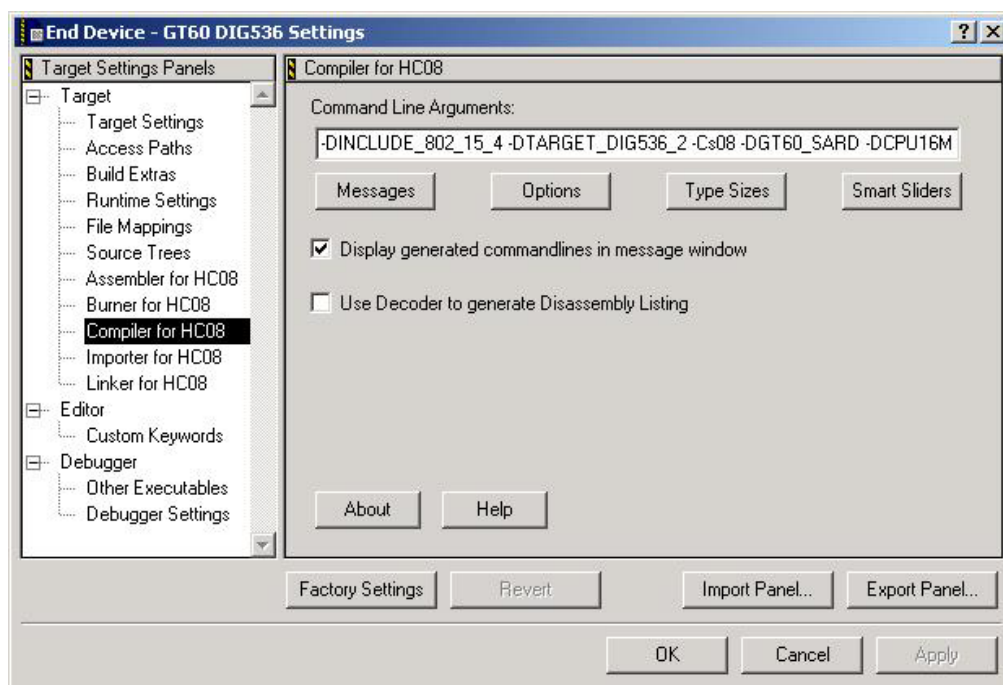

Figure 7: Manually setting compile

### 3.6 Differences between the Panasonic PAN802154 and the Freescale SARD Development Board

If the User is already familiar with the Freescale SARD Development Board – then using the PAN802154 is very easy.

The Panasonic PAN802154 has a different hardware configuration than the SARD board, improved RF performance, one switch versus four; one LED versus four; the RS-232 interface has an additional control connection to conserve power.

#### 3.6.1 Switch

Setting the target settings to the SARD affects all the pin-outs for the PAN802154. The SARD board layout includes four user switches labeled SW1, SW2, SW3, and SW4. However, the PAN802154 has only one and it is labeled SW1. Nothing needs to be done in software due to this difference in layouts. This should be kept in mind when attempting to run Freescale demonstration applications that uses these switches.

The port used is the same for SW1 (PTD0).

#### 3.6.2 LED

The SARD board had four LEDs as well, however, only one is used on the PAN802154. The port used for the LED (LED1) is PTD0, which is the same as LED1 on the SARD board. This should be kept in mind when developing software for the PAN802154s.

### 3.6.3 RS-232 Interface

The MCU has the capability to connect to two separate serial ports, however, the Panasonic PAN802154 has only one header for a serial port connection. This header is connected to SCI1 (serial communications interface 1).

The RS-232 IC used in the PAN802154 allows for a low-power sleep mode. Control of this sleep mode is done through a MCU I/O pin, PTC6. To force the RS-232 IC into a sleep mode, set pin PTC6 low. When the RS-232 IC is in sleep mode, the RS-232 will not operate. To wake the RS-232 IC up, set PTC6 high .

### 3.6.4 Editing SARD Header File for the Panasonic Module

Following sections show how to modify the SARD Header into the Panasonic PAN802154 Header File because of the difference in quantity of LEDs, Switches (or Push Buttons) as indicated in paragraphs above.

#### 3.6.4.1 Header File Modification for SMAC applications

For SMAC applications, the LED and SW definitions are in the application header file. To enable these applications to run on the PAN802154, just delete the lines from the header file that defines LED2, LED3 and LED4. Also, delete the lines that indicate PB1, PB2, and PB3 (Note the nomenclature difference – Panasonic uses SW; where as the SARD use PB). Also, be sure not to use these definitions in any of the ZigBee applications. The example given below is from wireless\_uart.h, which is at SMAC\_DIRECTORY\apps\Wireless Uart\Sources directory.

Example is below.

```
#if defined(MC13192SARD)
    #define LED1                PTDD_PTDD0
    #define LED1DIR             PTDDD_PTDDD0
    #define LED2                PTDD_PTDD1 <-- Delete
    #define LED2DIR             PTDDD_PTDDD1 <-- Delete
    #define LED3                PTDD_PTDD3 <-- Delete
    #define LED3DIR             PTDDD_PTDDD3 <-- Delete
    #define LED4                PTDD_PTDD4 <-- Delete
    #define LED4DIR             PTDDD_PTDDD4 <-- Delete
    #define LEDPORT             PTDD
    #define PB0                 PTAD_PTAD2
    #define PB0PU               PTAPE_PTAPE2
    #define PB0DIR              PTADD_PTADD2
    #define PB1                 PTAD_PTAD3 <-- Delete
    #define PB1PU               PTAPE_PTAPE3 <-- Delete
```

```

#define PB1DIR          PTADD_PTADD3 <-- Delete
#define PB2            PTAD_PTAD4   <-- Delete
#define PB2PU          PTAPE_PTAPE4 <-- Delete
#define PB2DIR        PTADD_PTADD4 <-- Delete
#define PB3            PTAD_PTAD5   <-- Delete
#define PB3PU          PTAPE_PTAPE5 <-- Delete
#define PB3DIR        PTADD_PTADD5 <-- Delete
#define PB0IE          KBI1PE_KBI1PE2
#define PB1IE          KBI1PE_KBI1PE3 <-- Delete
#define PB2IE          KBI1PE_KBI1PE4 <-- Delete
#define PB3IE          KBI1PE_KBI1PE5 <-- Delete
#define PRESSED 0

#endif

```

### 3.6.4.2 Header File Modification for 802.15.4 MAC applications

For 802.15.4 MAC applications, the Target.h header file needs to be edited in order to remove the configuration for the SW2, SW3, SW4 and LED2, LED3, LED4, as well as any Macros that exist for Switches and LED's that do not exist on the PAN802154. This file is in the 802.15.4 Directory under Src/GHDR/Target.h.

Also, no application should call any LED macros.

#### Port A and D Setup

Original code looks as follows

```

#define mSETUP_PORT_A  PTAPE = 0x3C;\   <-- Change to 0x04
                       PTADD = 0x00;

#define mSETUP_PORT_D  PTDPE = 0x00;\
                       PTDDD = (0x01 | 0x02 | 0x08 | 0x10); <-- only keep 0x01

```

After editing, the code will be as shown below

```

#define mSETUP_PORT_A  PTAPE = 0x04;\
                       PTADD = 0x00;

#define mSETUP_PORT_D  PTDPE = 0x00;\
                       PTDDD = (0x01);

```

#### LED Setup

Original code looks as follows

```

#define LED1_PIN  (1<<0)
#define LED2_PIN  (1<<1)      <- Delete

```

```
#define LED3_PIN (1<<3)      <- Delete
#define LED4_PIN (1<<4)      <- Delete

#define LED1ON PTDD &= 0xFE;
#define LED1OFF PTDD |= 0x01;
#define LED1TOGGLE PTDD ^= 0x01;

#define LED2ON PTDD &= 0xFD;      <- Delete
#define LED2OFF PTDD |= 0x02;      <- Delete
#define LED2TOGGLE PTDD ^= 0x02; <- Delete

#define LED3ON PTDD &= 0xF7;      <- Delete
#define LED3OFF PTDD |= 0x08;      <- Delete
#define LED3TOGGLE PTDD ^= 0x08; <- Delete

#define LED4ON PTDD &= 0xEF;      <- Delete
#define LED4OFF PTDD |= 0x10;      <- Delete
#define LED4TOGGLE PTDD ^= 0x10; <- Delete
```

After editing the header file for the PAN802154, the code will be as follows

```
#define LED1_PIN (1<<0)

#define LED1OFF PTDD &= 0xFE;
#define LED1ON PTDD |= 0x01;
#define LED1TOGGLE PTDD ^= 0x01;
```

### Switch Setup

#### Original code

```
#define mSWITCH1_MASK 0x04
#define mSWITCH2_MASK 0x08 <- Delete
#define mSWITCH3_MASK 0x10 <- Delete
#define mSWITCH4_MASK 0x20 <- Delete
#define mSWITCH_MASK 0x3C <- Change to 0x04
```

#### After Editing for the module

```
#define mSWITCH1_MASK 0x04
#define mSWITCH_MASK 0x04
```

### 3.6.4.3 Header file Modification for Z-Stack Applications

If compiling for a Z-Stack application, the header file OnBoard.h needs to be edited. This file is located at:

F8W\FS-1.0-1.0.0-RC2\Z-Stack\ZMain.

The Z-Stack uses this header file within the application framework, so the LED and SWITCH definitions cannot simply be deleted or the project will not build. Instead, they can just be set to 0 so that no action is taken if they attempt to be used.

It is important to note that the Z-Stack demo applications use the switches for various uses. But since some switches are not available on the PAN802154, these switch Macros must be set to 0 (deleting the LED macros will cause the Z-Stack to not compile).

### LED Macros

#### Original code

```
#define LED_NONE 0x00
#define LED1 0x01
#define LED2 0x02 <-- Set to 0
#define LED3 0x04 <-- Set to 0
#define LED4 0x08 <-- Set to 0
#define LED_ALL (LED1 | LED2 | LED3 | LED4) <-- Delete LED2,3,4
```

#### After Editing for the module, the code shall be

```
#define LED_NONE 0x00
#define LED1 0x01
#define LED2 0x00
#define LED3 0x00
#define LED4 0x00
#define LED_ALL (LED1)
```

### Switch Macros

#### Original code

```
#elif defined( GT60_SARD ) || defined ( GT60_EVB )
#define EVAL_SW_MASK 0x3C <-- Change to 0x04
#define EVAL_SW4 0x20
#define EVAL_SW3 0x10
#define EVAL_SW2 0x08
#define EVAL_SW1 0x04
```

#### After editing for the module

```
#elif defined( GT60_SARD ) || defined ( GT60_EVB )
#define EVAL_SW_MASK 0x04
#define EVAL_SW4 0x20
#define EVAL_SW3 0x10
#define EVAL_SW2 0x08
#define EVAL_SW1 0x04
```

### 3.7 How to load a SW program into the Panasonic Module

The following example shows a step-by-step for loading software build for a Z-Stack application to the PAN802154.

1. Open Metrowerks Codewarrior Development Studio for HC(S) 08.
2. Open one of the example projects in the Z-Stack directory. This example uses the Home lighting Controls project. In Codewarrior IDE, select File->Open. The location is

C:\F8WFS-1.0-1.0.0-RC2\Z-Stack\Projects\HomeLighting\SLC03394\MC13192Zstack\_SLC03394.mcp

The project will open and your screen will appear as below.

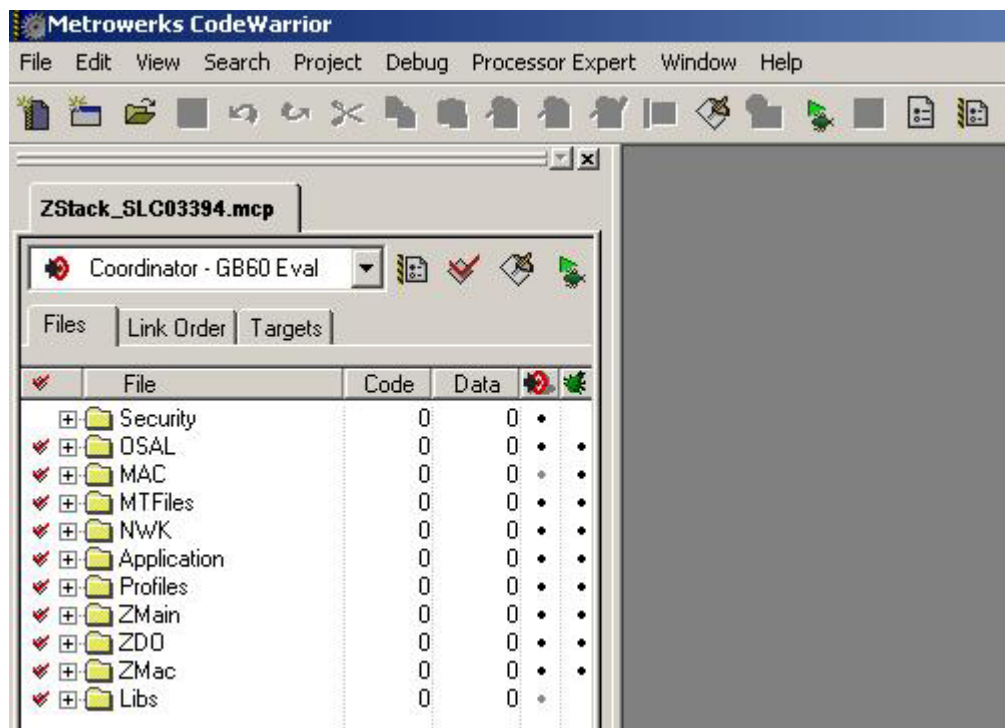

**Figure 8: Z-Stack application**

- The project needs to be mapped to the correct hardware configuration. This is accomplished by clicking the down-facing arrow and selecting the target as XXX – GT60 DIG536. This sets up the compile options (XXX is Coordinator, Router, or End Device, depending on the application that is to be loaded into the PAN802154).

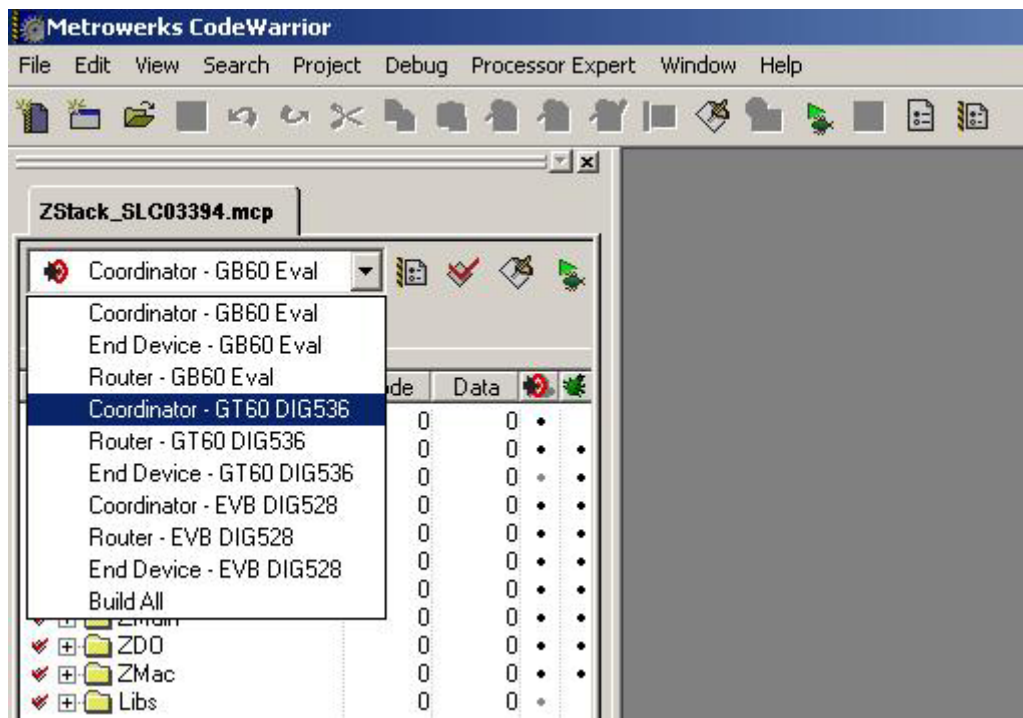

**Figure 9: Mapping the hardware configuration**

4. To load the software, connect the BDM-Multilink 6-pin connector to J5 header on the PAN802154. Click the green button circled below. The code will compile and download the program to the Module.

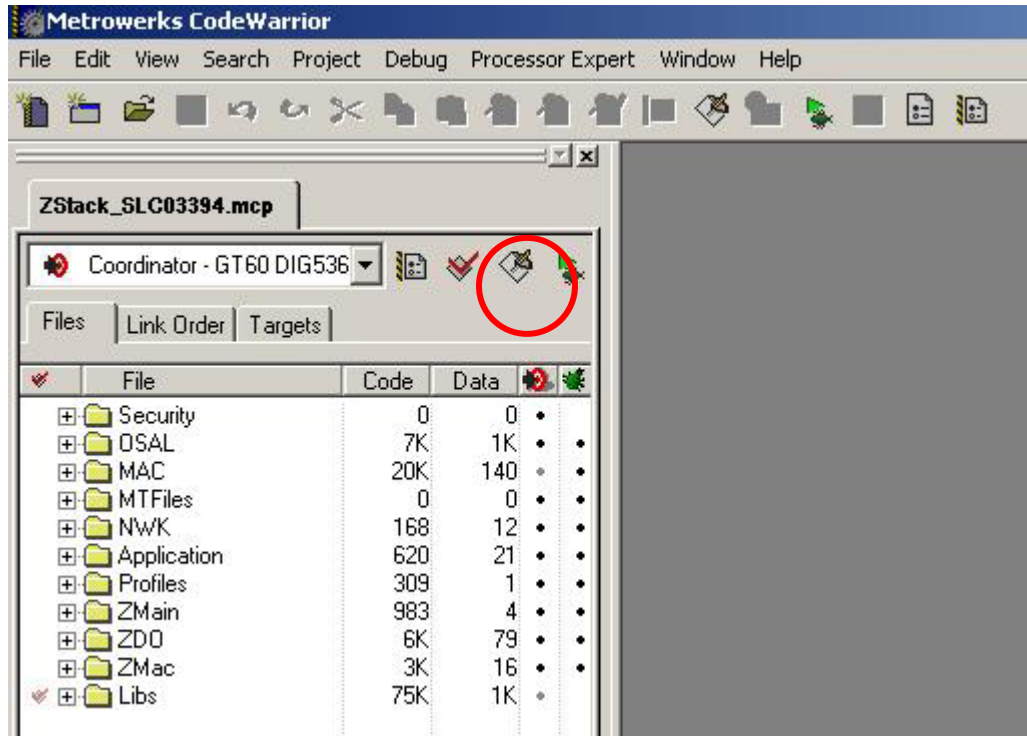

**Figure 10: Loading the application**

**Page intentionally blank.**

## 4 FREQUENTLY ASKED QUESTIONS

### **Q1: What is the LR/WPAN PAN802154HAR00 Panasonic Module?**

**A:** The PAN802154 is a low rate / low power communication radio module adapting from the Freescale SARD platform. It is fully 802.15.4 compatible with a Freescale™ ZigBee Protocol stack. It has 1 Push-button switch, 1 LED, 1 RS-232 port, general-purpose header with 6 digital I/O and 2 analog inputs for A/D conversion (The 2 analog inputs can be used as Digital I/Os). The PAN802154 also has on board antenna for cost reduction and meets FCC requirements.

### **Q2: Does my end product have to get FCC certification and ZigBee certification if we use the Module?**

**A:** Although the PAN802154 is already tested at Panasonic factory for FCC compliance, the end product will need to be certified as an end consumer item. Ditto for the ZigBee compliance for your specific end product Application SW.

### **Q3: Does the ZigBee stack come with the PAN802154? What form does it come in and what is included?**

**A:** Yes. The Freescale ZigBee stack itself is provided in object code form, however, an example for application framework and operating system environment is provided in source-code form. The Stack is available for download from the Freescale website.

### **Q4: Is there any development tool for using the Z-Stack?**

**A:** The Z-Stack has development tools that assist in application development and deployment. The Z-stack tools are available for the following development purposes.

- a.) Z-Tool for debugs
- b.) Configurator for embedded application setup and source code generation.
- c.) Profile-builder for building custom ZigBee profiles
- d.) Z-Network for providing a graphical representation of a ZigBee Network.

### **Q5: Same question as above, but for 802.15.4 MAC**

**A:** 802.15.4 MAC is separated into a PHY and a MAC layer. The PHY layer is provided in source-code form. Pre-built libraries are provided for all Freescale's development platforms. The MAC is provided in library form only.

### **Q6: Does the PAN802154 correspond to any Freescale Development Platform?**

**A:** The PAN802154 adapts the Freescale™'s SARD development platform. The part number for the SARD board is DIG536-2, and the design can be found on Freescale's website. The PAN802154 contains only 1 push-button switch and 1 LED, whereas the SARD board has 4 switches and 4 LEDs. The PAN802154 has an extra signal goes to the RS-232 chip to enable sleep-mode on the RS-232 chip to save power.

**Q7: What compiler is used for ZigBee application development?**

**A:** Metrowerks CodeWarrior Development Studio for HC (S) 08 64K Compiler is the compiler. Libraries and source code projects provided by Freescale™ are compatible with this compiler. The compiler can be found on Freescale's website at [www.freescale.com](http://www.freescale.com). The 64K-compiler upgrade is needed to compile the full ZigBee stack.

**Q8: Do the PAN802154s come with any software loaded onto them?**

**A:** The modules will come loaded with a Bootloader (Engineering samples may contain sample applications). The Bootloader allows software to be downloaded to the PAN802154 through the serial port. A command-line interface to this Bootloader is provided by Freescale™ and available for download.

**Q9: Is any special hardware needed to load code to the ZigBee modules?**

**A:** Loading of software can be done through a standard serial port connected to a PC and Freescale's serial Bootloader application (Freescale's specific bootloader.s19 file must be downloaded into module's flash before this feature can be used). File format for this loading is Motorola s-record (S19) files. If more control of software loading and flash erasing is desired; a hardware debugger is available from [www.pemicro.com](http://www.pemicro.com). Part number is BDM-MULTILINK (uses pc's parallel port) or USB-ML-12 (uses pc's USB port).

**Q10: What programming language is used for application programming?**

**A:** Standard C is used to write the embedded applications. Some assembly can be used for speed-critical sections of code.

**Q11: What are the power supply requirements?**

**A:** For wireless communication without using the RS-232, the power supply voltage must be between 2.2 and 3.4 volts DC. With RS-232 operation, the supply voltage must be between 3 and 3.4 volts DC.

**Q12: What distance can be expected for wireless communication?**

**A:** Line of sight communication between two modules can be as far as 200 meters. With a few stucco walls, in a building environment the distance between the two modules could be as good as 30 meters.

**Q13: Describe the general-purpose I/O header?**

**A:** The PAN802154 contains a 10-pin general purpose I/O header. This header provides up to 8 digital I/O. Two of the digital I/O pins can also be used as analog inputs to the analog-to-digital converter in the MCU. Power and Ground are also provided on this header.

**Q14: What is the baud rate for the serial port?**

**A:** The baud-rate is programmable.

**Q15: What kind of battery life is expected?**

**A:** The battery-life for the PAN802154 is entirely dependent on the application. In applications that only require only a few transmissions per hour, batteries may last several years, alternately, in applications that require continuous transmissions batteries may only last a few months.

**Q16: How big is the Freescale ZigBee stack?**

**A:** Version 1.0 stack size is dependent on the device type. Below is a simple table for current sizes of ZigBee stack + 802.15.4 MAC, including security. More code-size reduction efforts are taking place.

|              |              |
|--------------|--------------|
| Coordinator: | 54,714 bytes |
| Router:      | 51,705 bytes |
| Node:        | 43,053 bytes |

Note that with this code size, for the GT60 MCU a fair amount of ROM (equals to 60Kbytes minus the amount used above for each type) is still available from the Flash to store the application program. The above code size is expected to be substantially smaller in future releases.

**Q17: Can I use the PAN802154 with another protocol stack other than the Freescale ZigBee stack?**

**A:** Yes. As long as the replaceable stack is compatible with the Freescale provided 802.15.4 PHY / MAC; and it is also compiled for the GT60 MCU and MC13193 Transceiver.

**Q18: Can I use the PAN802154 with the SMAC only for my simple legacy system?**

**A:** Yes. For simple legacy application program, you can just use the SMAC only.

## 5 REFERENCE DOCUMENTS

Panasonic LR/WPAN802154HAR00 Specification

From Freescale - Documents below are downloadable from Freescale™ website  
<http://www.freescale.com/ZigBee>

### SMAC

Doc. Title: Simple Media Access Controller User's Guide

Doc. Num: SMACRM/D

### 802.15.4 MAC

Doc. Title: 802.15.4 MAC/PHY Software Reference Manual

Doc. Num: 802154MPSRM/D

Doc. Title: 802.15.4 MAC/PHY Software Users Guide

Doc. Num: 802154MPSUG/D

### Z-Stack

#### High-Level Design

Doc. Title: Z-Stack Application Framework (AF) Application Programming Interface

Doc. Num: F8W-2003-0010

Doc. Title: Z-Stack Application Framework (AF) Application Programming Interface

Doc. Num: F8W-2003-0025

Doc. Title: Z-Stack Compile Flag Definitions

Doc. Num: F8W-2004-0013

Doc. Title: Z-Stack Device Object (ZDO) Application Programming Interface

Doc. Num: F8W-2004-0025

Doc. Title: ZigBee Device Object Programmer's Guide

Doc. Num: F8W-2004-0008

Doc. Title: Z-Stack Network (NWK) Application Programming Interface

Doc. Num: F8W-2003-0008

Doc. Title: ZigBee Dimmer Load Controller (03395) Device Description Programmer's Guide

Doc. Num: F8W-2003-0034

Doc. Title: ZigBee Dimmer Remote Control (03392) Device Description Programmer's Guide

Doc. Num: F8W-2003-0033

Doc. Title: ZigBee Generic Application Programmer's Guide

Doc. Num: F8W-2003-0032

Doc. Title: ZigBee Light Sensor Monochromatic (02080) Device Description Programmer's Guide

Doc. Num: F8W-2003-0029

Doc. Title: ZigBee Occupancy Sensor (03393) Device Description Programmer's Guide

Doc. Num: F8W-2003-0035

Doc. Title: ZigBee Serial Application Programmer's Guide

Doc. Num: F8W-2003-0018

Doc. Title: ZigBee Switch Load Controller (03394) Device Description Programmer's Guide

Doc. Num: F8W-2003-0028

Doc. Title: ZigBee Switch Remote Control (03391) Device Description Programmer's Guide  
Doc. Num: F8W-2003-0027

#### Integration Test

Doc. Title: Z-Stack Integration Test Plan  
Doc. Num: F8W-2003-0021

#### OS Abstraction Layer

Doc. Title: Z-Stack OS Abstraction Application Programming Interface  
Doc. Num: F8W-2003-0002

#### Serial Port Interface

Doc. Title: Z-Stack/Z-Test Serial Port Interface  
Doc. Num: F8W-2003-0001

## *APPENDIX 1 FCC AND CANADA CERTIFICATIONS*

---

### Instruction to the user

#### **47 C.F.R. Sec. 15.21**

This equipment has been tested and found to comply with the limits for a Class B digital device, pursuant to part 15 of the FCC Rules. These limits are designed to provide reasonable protection against harmful interference in a residential installation. This equipment generates uses and can radiate radio frequency energy and, if not installed and used in accordance with the instructions, may cause harmful interference to radio communications. However, there is no guarantee that interference will not occur in a particular installation. If this equipment does cause harmful interference to radio or television reception, which can be determined by turning the equipment off and on, the user is encouraged to try to correct the interference by one or more of the following measures:

- Reorient or relocate the receiving antenna.
- Increase the separation between the equipment and receiver.
- Connect the equipment into an outlet on a circuit different from that to which the receiver is connected.
- Consult the dealer or an experienced radio/TV technician for help.

#### **47 C.F.R. Sec.15.105(b)**

This equipment complies with FCC radiation exposure limits set forth for an uncontrolled environment. The antenna(s) used for this equipment must be installed to provide a separation distance of at least 8 inches (20cm) from all persons.

### **Integration in OEM products: VERY IMPORTANT!**

The **PAN802154** module (ZB-01) has been certified as a transmitter module by the FCC rule 15 and Industry Canada. It can be integrated into OEM products without obtaining subsequent and separate FCC approvals according to the FCC public notice DA 00-1407 June 26, 2000.

The OEM must satisfy the following requirements to comply with the FCC regulations:

- 1) The OEM integrator will not use the Panasonic FCC ID or Canada grant code with out a previous contract agreement on which the exact application and scope of the final product will be declared.
- 2) If the **PAN802154** is integrated in another enclosure and the FCC label is not visible, then the device into which the module is installed must also display a label such as the Figure11.

This device Contain a transmitter module: PAN802154 HAR00

IC: Pending

FCC ID: Pending

\* The enclosed device complies with Part 15 of the FCC Rules. Operation is subject to the following two conditions: (1) This device may not cause harmful interference, and (2) This device must accept any interference received, including interference that may cause undesired operation.

**Figure 11: Label to be attached to the outside of the OEM product**

- 3) The users manual should include a statement such as the one in figure 2:

**CAUTION STATEMENT!**

**47 C.F.R. Sec. 15.21**

This equipment has been tested and found to comply with the limits for a Class B digital device, pursuant to part 15 of the FCC Rules. These limits are designed to provide reasonable protection against harmful interference in a residential installation. This equipment generates uses and can radiate radio frequency energy and, if not installed and used in accordance with the instructions, may cause harmful interference to radio communications. However, there is no guarantee that interference will not occur in a particular installation. If this equipment does cause harmful interference to radio or television reception, which can be determined by turning the equipment off and on, the user is encouraged to try to correct the interference by one or more of the following measures:

- Reorient or relocate the receiving antenna.
- Increase the separation between the equipment and receiver.
- Connect the equipment into an outlet on a circuit different from that to which the receiver is connected.
- Consult the dealer or an experienced radio/TV technician for help.

**Figure 12: Caution statement to be included in OEM users manual**

- 4) Any modification to this product may violate the rules of Federal Communications Commission and make the operation of the product unlawful. If the OEM integrates the module into their final product, where the final product utilizes non-approved antennas or is classified as a portable device per FCC Section 2.1093, the OEM is responsible for obtaining a separate authorization on the final product.
- 5) The module has been designed and tested for battery operation. The OEM is responsible for conducted emissions compliance and has to demonstrate that it pass the conducted limits if the final product include or make provisions for the use of battery eliminators or AC adapters or if it gets power indirectly from AC lines.
- 6) OEM is responsible for the compliance of the FCC regulations for Unintentional radiators section 15.107 and 15.109 on their final product.

***APPENDIX 2 ORDERING INFORMATION***

RF module ( example only)

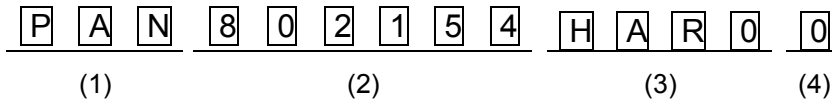

(1) Product Code

(2) Product Series

(3) Product Type

H: Header Connector

A: On Board Antenna

R: RS-232C interface

0: Commercial Temperature Range; I: Industrial Temperature Range.

(4) Design version number