

(EMI)

# TEST REPORT

**REPORT NUMBER** : **TR 00-0032**

**APPLICANT** : **KYUSHU MATSUSHITA ELECTRIC CO., LTD.**  
**PRINTER DIVISION**

**MODEL NUMBER** : **KX-P8425**

**REGULATION** : **FCC Rules and Regulations Part 15**  
**Subpart B - Unintentional Radiators**

**ISSUE DATE** : **July 24, 2000**

**Kyushu Matsushita Electric Test Lab**  
**EMC Center**

Kyushu Matsushita Electric Test Lab Co.,Ltd.

441-13, Nagahasu Tateishi-cho, Tosu,  
Saga 841-8585, Japan

TEL 0942-84-8472 (+81-942-84-8472)

FAX 0942-84-8470 (+81-942-84-8470)

**KME**

**TABLE of CONTENTS**

---

	Page
SECTION 1. EMI TEST REPORT ON EUT	3
SECTION 2. TEST CERTIFICATION	3
SECTION 3. TEST RESULTS EMISSION	
3.1 Radiated Emission	4 - 7
3.2 Conducted Emission	8, 9
SECTION 4. DESCRIPTION OF TEST EQUIPMENT	
4.1 Construction of Equipment	10
4.2 EUT and Support Equipment Used	10
4.3 Cable(s) Used	11
4.4 Operating Conditions	12
4.5 Any Deviations from, Additions to or Exclusions from the Test Method	12
SECTION 5. PHOTOGRAPHS OF MAXIMUM EMISSION SET-UP	
5.1 Radiated Emission	13
5.2 Conducted Emission	14
SECTION 6. TEST ARRANGEMENT AND LIST OF TEST INSTRUMENTS	
6.1 Radiated Emission	15
6.2 Conducted Emission	16

---

**SECTION 1. EMI TEST REPORT ON EUT****APPLICANT INFORMATION**

Company	:	Kyushu Matsushita Electric Co., Ltd. Printer Division
Address	:	1471, Murata-machi, Tosu, Saga 841-8501, Japan
Phone Number	:	0942-83-3131 (+81-942-83-3131)
Facsimile Number	:	0942-81-2725 (+81-942-81-2725)

**DESCRIPTION of TEST ITEM**

Kind of Equipments	:	Color Laser Printer
Condition of Equipment	:	Pre-Production
Type	:	Tabletop Type
Brand	:	Panasonic
Model Number	:	KX-P8425
Serial Number	:	OEMFOA00027
Power Supply	:	AC 120V 60Hz

**TEST PERFORMED**

Location	:	Kyushu Matsushita Electric Test Lab EMC Center (Semi-Anechoic Chamber, Shielded Room) (FCC File No. 31040/SIT 1300F2)
Address	:	441-13, Nagahasu Tateishi-cho, Tosu, Saga 841-8585, Japan
Receipt Date	:	July 17, 2000
Test Date	:	July 17, 2000
Regulation	:	FCC Rules and Regulations Part 15 Subpart B Class B
Test Procedure	:	ANSI C63.4-1992

**SECTION 2. TEST CERTIFICATION****1.Measurement Results**

The results obtained from the measurement of the above mentioned device are shown in the attached sheets. The results in this report apply only to the sample(s) tested.

**2.Summary of Results**

Test sample complies with FCC Rules and Regulations

Part 15 Subpart B - Unintentional Radiators(Class B).

Worst Margin(Radiated Emission) -- 31.766MHz (V) 5.5dB (at page 6)

Worst Margin(Conducted Emission) -- 14.6956MHz 11.6dB (at page 8)

**3.These test results are traceable to the National and International Standards.****4.Measurements Uncertainty, at time of test, and at last 95% Confidence, was estimated to be as follows:**

Radiated Emission Measurements :

5.46dB(3m)[30M-300MHz], 4.76dB(3m)[300M- 1GHz]

Conducted Emission Measurements:

2.40dB[0.09M- 1MHz], 2.63dB[1M-30MHz]

Issue Date : July 24, 2000

Reviewed by : M.Horie 

Certifying  
Manager : H.Hara 

### SECTION 3. TEST RESULTS EMISSION

#### 3.1 Radiated Emission

##### 3.1.1 Parallel / Ethernet Printing

Model Name : Color Laser Printer  
 Model No. : KX-P8425  
 Serial No. : 0EMFOA00027  
 Operator : T.Yamagami  
 Points : 11  
 Detector : QP  
 RBW : 120kHz

##### Test Condition of Instrument

Date : 2000/07/17 09:33  
 Temperature : 26deg  
 Humidity : 60%  
 EUT Warm-up Time : 30minutes  
 Distance : 3m  
 Test Mode : Parallel / Ethernet Printing  
 Comment : AC 120V 60Hz

The measurement was radiated the worst emissions condition.

Level=Emission Level=Meter Reading+Antenna Factor+Cable Loss(Cable, Preamp)

LIMIT : FCC Part15 Class B (3m)

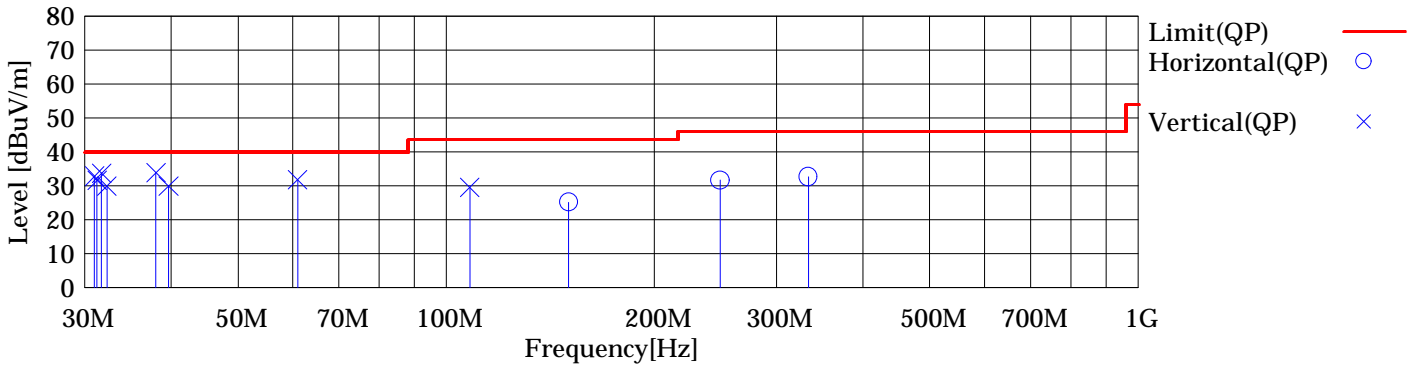

Frequency [MHz]	Meter Reading (QP) [dBuV]	Ant. Type	Antenna Factor [dB/m]	Cable & Preamp [dB]	Level (QP) [dBuV/m]	Angle [deg]	Height [cm]	Pola.	Limit [dBuV/m]	Margin [dB]
150.392	34.0	BC	15.0	-23.9	25.1	5	209	Hori.	43.5	18.4
248.985	36.5	BC	17.8	-22.7	31.6	156	252	Hori.	46.0	14.4
333.843	38.5	LP	16.4	-22.3	32.6	152	182	Hori.	46.0	13.4
31.020	39.6	BC	19.4	-26.2	32.8	31	100	Vert.	40.0	7.2
31.260	38.5	BC	19.3	-26.2	31.6	43	100	Vert.	40.0	8.4
31.743	40.7	BC	19.2	-26.2	33.7	276	100	Vert.	40.0	6.3
32.314	36.9	BC	19.0	-26.1	29.8	89	100	Vert.	40.0	10.2
38.048	43.0	BC	16.9	-26.0	33.9	47	100	Vert.	40.0	6.1
39.674	39.6	BC	16.3	-26.0	29.9	3	100	Vert.	40.0	10.1
60.983	48.3	BC	8.9	-25.5	31.7	110	100	Vert.	40.0	8.3
108.131	42.5	BC	11.7	-24.7	29.5	226	100	Vert.	43.5	14.0

BC:Biconical LP:Log-periodic DP:Dipole SDP:Short Dipole

Tested by T.Yamagami

3.1.2 Parallel / Ethernet Printing

Model Name : Color Laser Printer  
 Model No. : KX-P8425  
 Serial No. : OEMFOA00027  
 Operator : T.Yamagami  
 Points : 3  
 Detector : AV  
 RBW : 1MHz

Test Condition of Instrument

Date : 2000/07/17 14:04  
 Temperature : 26deg  
 Humidity : 60%  
 EUT Warm-up Time : 30minutes  
 Distance : 3m  
 Test Mode : Parallel / Ethernet Printing  
 Comment : AC 120V 60Hz  
 :

The measurement was radiated the worst emissions condition.

Level=Emission Level=Meter Reading+Antenna Factor+Cable Loss (Cable, Preamp)

LIMIT : FCC Part15 ClassB

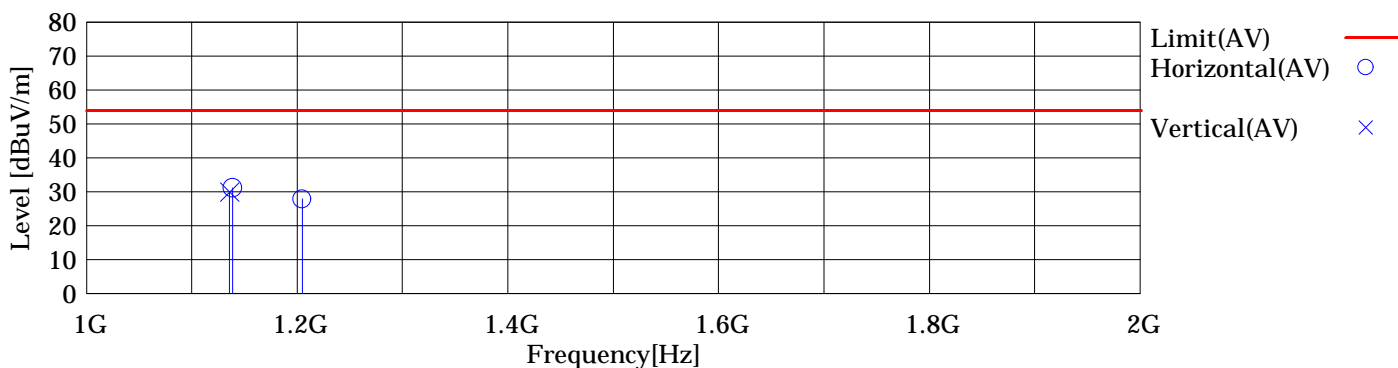

Frequency [MHz]	Meter Reading (AV) [dBuV]	Ant. Type	Antenna Factor [dB/m]	Cable & Preamp [dB]	Level (AV) [dBuV/m]	Angle [deg]	Height [cm]	Pola.	Limit [dBuV/m]	Margin [dB]
1138.710	41.5	HN	26.1	-36.5	31.1			Hori.	53.9	22.8
1204.757	37.9	HN	26.2	-36.3	27.8			Hori.	53.9	26.1
1135.849	40.2	HN	26.1	-36.5	29.8			Vert.	53.9	24.1

HN:Horn

Tested by T.Yamagami

3.1.3 USB Printing

Model Name : Color Laser Printer  
 Model No. : KX-P8425  
 Serial No. : 0EMFOA00027  
 Operator : T.Yamagami  
 Points : 9  
 Detector : QP  
 RBW : 120kHz

Test Condition of Instrument

Date : 2000/07/17 11:21  
 Temperature : 26deg  
 Humidity : 60%  
 EUT Warm-up Time : 30minutes  
 Distance : 3m  
 Test Mode : USB Printing  
 Comment : AC 120V 60Hz  
 :

The measurement was radiated the worst emissions condition.

Level=Emission Level=Meter Reading+Antenna Factor+Cable Loss(Cable, Preamp)

LIMIT : FCC Part15 Class B (3m)

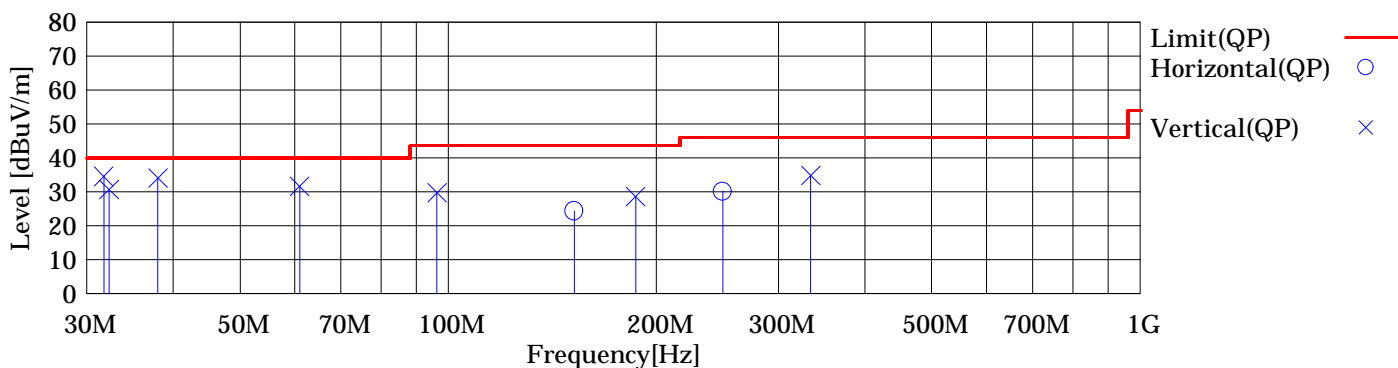

Frequency [MHz]	Meter Reading (QP) [dBuV]	Ant. Type	Antenna Factor [dB/m]	Cable & Preamp [dB]	Level (QP) [dBuV/m]	Angle [deg]	Height [cm]	Pola.	Limit [dBuV/m]	Margin [dB]
152.152	33.1	BC	15.1	-23.9	24.3	209	100	Hori.	43.5	19.2
249.383	34.9	BC	17.8	-22.6	30.1	172	126	Hori.	46.0	15.9
31.766	41.5	BC	19.1	-26.1	34.5	286	100	Vert.	40.0	5.5
32.331	37.8	BC	18.9	-26.1	30.6	89	100	Vert.	40.0	9.4
38.054	43.2	BC	16.8	-26.0	34.0	30	100	Vert.	40.0	6.0
60.991	48.1	BC	8.9	-25.4	31.6	99	100	Vert.	40.0	8.4
96.343	44.2	BC	10.3	-24.8	29.7	262	100	Vert.	43.5	13.8
186.551	35.1	BC	16.8	-23.3	28.6	303	100	Vert.	43.5	14.9
334.243	40.7	LP	16.4	-22.3	34.8	183	100	Vert.	46.0	11.2

BC:Biconical LP:Log-periodic DP:Dipole SDP:Short Dipole

Tested by T.Yamagami

3.1.4 USB Printing

Model Name : Color Laser Printer  
 Model No. : KX-P8425  
 Serial No. : 0EMFOA00027  
 Operator : T.Yamagami  
 Points : 2  
 Detector : AV  
 RBW : 1MHz

Test Condition of Instrument

Date : 2000/07/17 15:25  
 Temperature : 26deg  
 Humidity : 60%  
 EUT Warm-up Time : 30minutes  
 Distance : 3m  
 Test Mode : USB Printing  
 Comment : AC 120V 60Hz  
 :

The measurement was radiated the worst emissions condition.

Level=Emission Level=Meter Reading+Antenna Factor+Cable Loss (Cable, Preamp)

LIMIT : FCC Part15 ClassB

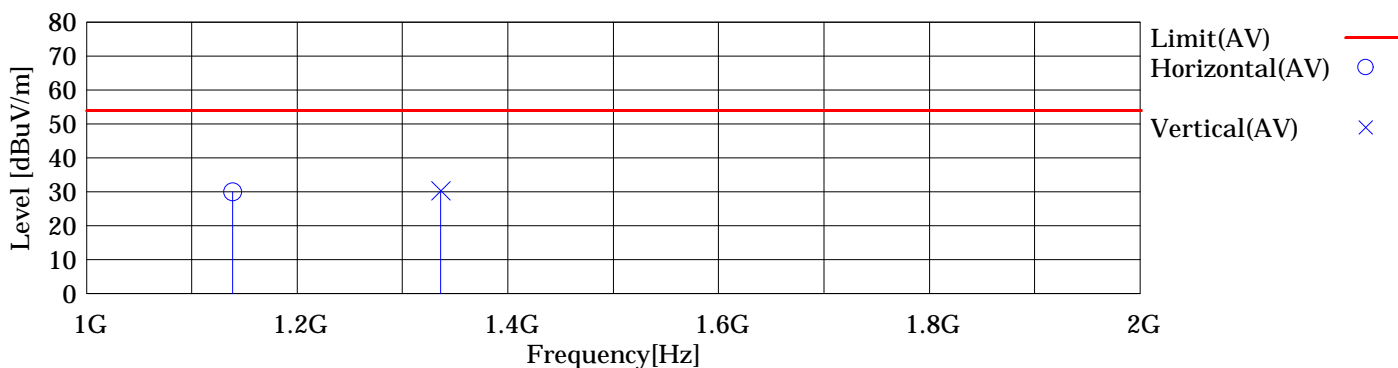

Frequency [MHz]	Meter Reading (AV) [dBuV]	Ant. Type	Antenna Factor [dB/m]	Cable & Preamp [dB]	Level (AV) [dBuV/m]	Angle [deg]	Height [cm]	Pola.	Limit [dBuV/m]	Margin [dB]
1138.939	40.3	HN	26.1	-36.5	29.9			Hori.	53.9	24.0
1336.231	39.6	HN	26.6	-36.0	30.2			Vert.	53.9	23.7

HN:Horn

Tested by T.Yamagami

3.2 Conducted Emission

3.2.1 Parallel / Ethernet Printing

Model Name : Color Laser Printer  
 Model No. : KX-P8425  
 Serial No. : 0EMFOA00027  
 Operator : T.Yamagami  
 Points : 14  
 Detector : QP  
 RBW : 10kHz

Test Condition of Instrument

Date : 2000/07/17 17:51  
 Temperature : 25deg  
 Humidity : 58%  
 EUT Warm-up Time : 30minutes  
 Test Mode : Parallel / Ethernet Printing  
 Comment : AC 120V 60Hz

The measurement was conducted the worst emissions condition.  
 Level=Emission Level=Meter Reading+Factor (Cable, LISN)

LIMIT : FCC Part15 Class B (QP)

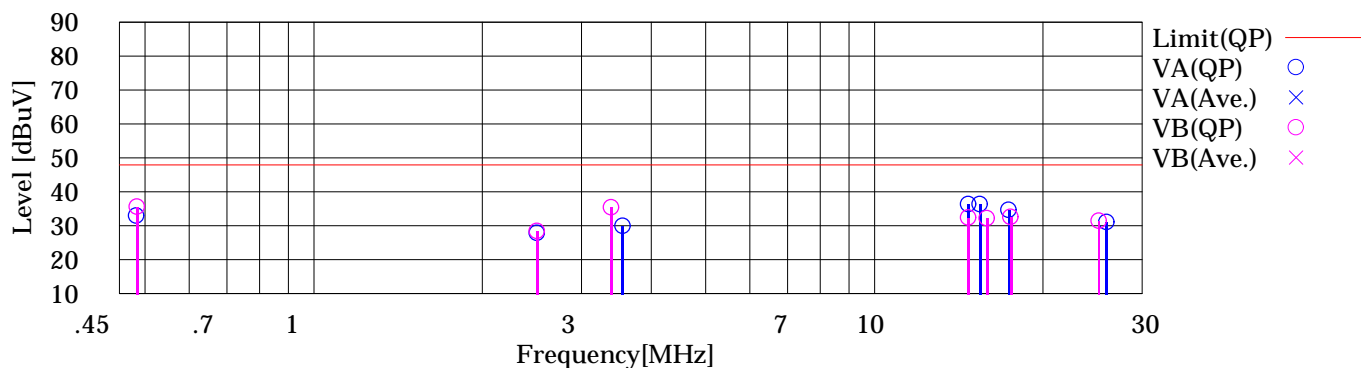

Frequency [MHz]	Meter Reading (QP) [dBuV]	Meter Reading (Ave.) [dBuV]	Factor [dB]	Level (QP) [dBuV]	Level (Ave.) [dBuV]	Line	Limit (QP) [dBuV]	Limit (Ave.) [dBuV]	Margin (QP) [dB]	Margin (Ave.) [dB]
0.4831	32.8	----	0.1	32.9	----	VA	47.9	0.0	15.0	----
2.5033	27.6	----	0.2	27.8	----	VA	47.9	0.0	20.1	----
3.5545	29.6	----	0.2	29.8	----	VA	47.9	0.0	18.1	----
14.6956	35.8	----	0.5	36.3	----	VA	47.9	0.0	11.6	----
15.4206	35.8	----	0.5	36.3	----	VA	47.9	0.0	11.6	----
17.3642	34.0	----	0.5	34.5	----	VA	47.9	0.0	13.4	----
25.9206	30.3	----	0.7	31.0	----	VA	47.9	0.0	16.9	----
0.4839	35.4	----	0.1	35.5	----	VB	47.9	0.0	12.4	----
2.5030	28.1	----	0.2	28.3	----	VB	47.9	0.0	19.6	----
3.3902	35.1	----	0.2	35.3	----	VB	47.9	0.0	12.6	----
14.6928	31.8	----	0.5	32.3	----	VB	47.9	0.0	15.6	----
15.8888	31.6	----	0.5	32.1	----	VB	47.9	0.0	15.8	----
17.5051	32.0	----	0.5	32.5	----	VB	47.9	0.0	15.4	----
25.1042	30.7	----	0.6	31.3	----	VB	47.9	0.0	16.6	----

Tested by T.Yamagami

3.2.2 USB Printing

Model Name : Color Laser Printer  
 Model No. : KX-P8425  
 Serial No. : 0EMFOA00027  
 Operator : T.Yamagami  
 Points : 16  
 Detector : QP  
 RBW : 10kHz

Test Condition of Instrument

Date : 2000/07/17 18:55  
 Temperature : 25deg  
 Humidity : 58%  
 EUT Warm-up Time : 30minutes  
 Test Mode : USB Printing  
 Comment : AC 120V 60Hz

The measurement was conducted the worst emissions condition.  
 Level=Emission Level=Meter Reading+Factor (Cable, LISN)

LIMIT : FCC Part15 Class B (QP)

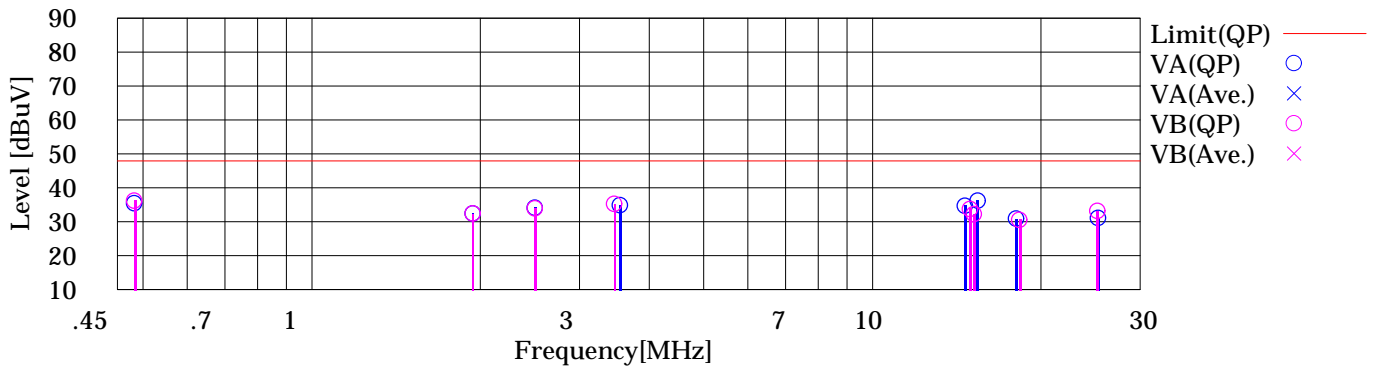

Frequency [MHz]	Meter Reading (QP) [dBuV]	Meter Reading (Ave.) [dBuV]	Factor [dB]	Level (QP) [dBuV]	Level (Ave.) [dBuV]	Line	Limit (QP) [dBuV]	Limit (Ave.) [dBuV]	Margin (QP) [dB]	Margin (Ave.) [dB]
0.4832	35.3	----	0.1	35.4	----	VA	47.9	0.0	12.5	----
1.9371	32.2	----	0.2	32.4	----	VA	47.9	0.0	15.5	----
2.5032	33.9	----	0.2	34.1	----	VA	47.9	0.0	13.8	----
3.5517	34.5	----	0.2	34.7	----	VA	47.9	0.0	13.2	----
14.6100	34.2	----	0.4	34.6	----	VA	47.9	0.0	13.3	----
15.4191	35.7	----	0.5	36.2	----	VA	47.9	0.0	11.7	----
18.0453	30.3	----	0.5	30.8	----	VA	47.9	0.0	17.1	----
25.2636	30.4	----	0.6	31.0	----	VA	47.9	0.0	16.9	----
0.4831	36.1	----	0.1	36.2	----	VB	47.9	0.0	11.7	----
1.9371	32.1	----	0.2	32.3	----	VB	47.9	0.0	15.6	----
2.5013	33.7	----	0.2	33.9	----	VB	47.9	0.0	14.0	----
3.4696	34.9	----	0.2	35.1	----	VB	47.9	0.0	12.8	----
14.9276	33.2	----	0.5	33.7	----	VB	47.9	0.0	14.2	----
15.1701	31.6	----	0.5	32.1	----	VB	47.9	0.0	15.8	----
18.3031	30.0	----	0.5	30.5	----	VB	47.9	0.0	17.4	----
25.1852	32.4	----	0.6	33.0	----	VB	47.9	0.0	14.9	----

Tested by T.Yamagami

## SECTION 4. DESCRIPTION OF TEST EQUIPMENT

### 4.1 Construction of Equipment

The Construction of EUT during the test as follows.

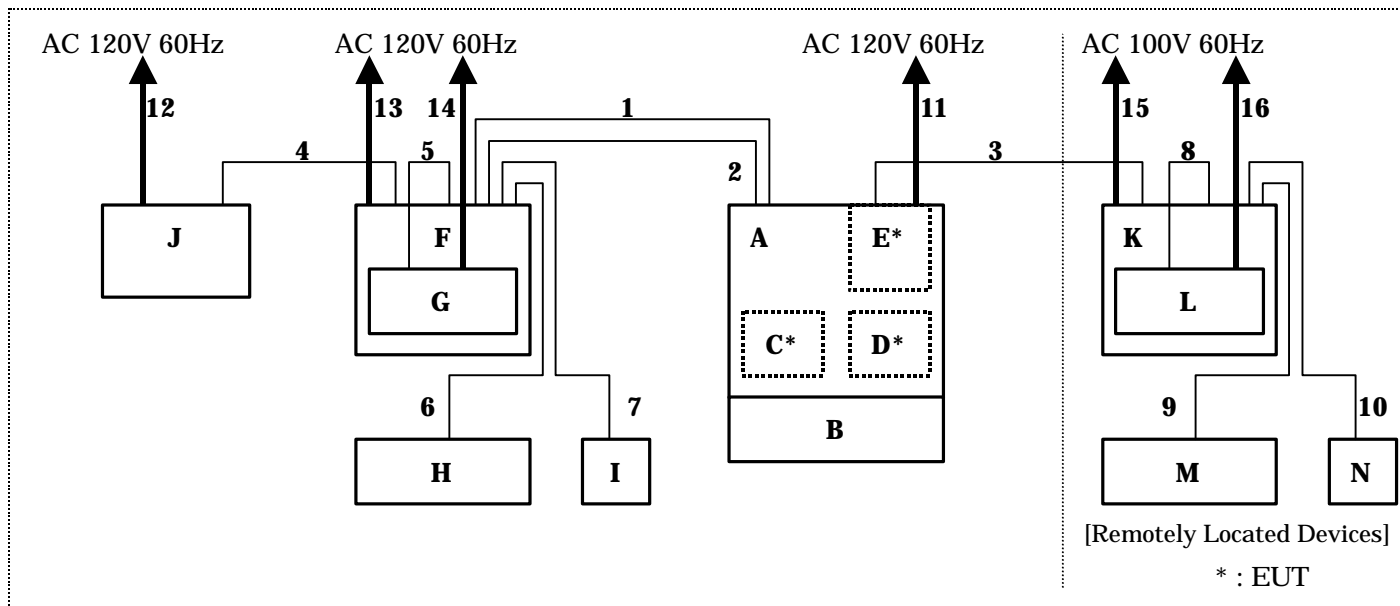

Symbol or number assigned to equipments or cables on this diagram was used on tables in section 4.2 to 4.3.

### 4.2 EUT and Support Equipment Used

The EUT was supported by the following equipments during the test.

Indication in the following left side column corresponds to section 4.1

	Item	Model No. [Manufacturer]		Serial No.	FCC I/D
<b>A</b>	Color Laser Printer [EUT]	KX-P8425	[KME]	0EMFOA00027	N.A.
<b>B</b>	2 <sup>nd</sup> Cassette Feeder with Auto Duplex Unit [EUT]	KX-PCSF2	[KME]	9DSFBC07627	N.A.
<b>C</b>	128MB SO-DIMM [EUT]	KX-PEMS2	[KME]	0ECMA00001	N.A.
<b>D</b>	HDD [EUT]	KX-PDHD2	[KME]	0ECMA00001	N.A.
<b>E</b>	Ethernet NIC [EUT]	KX-PNBC9	[KME]	0ECMA00001	N.A.
<b>F</b>	Computer	D6553-WJ101	[HEWLETT PACKARD]	SG83901455	DoC
<b>G</b>	CRT Display	ASTSVGA-LR14	[AST]	92240043	GWG-XXX449XC
<b>H</b>	Keyboard	SK-2502	[HEWLETT PACKARD]	M980900431	GYUR41SK
<b>I</b>	Mouse	M-S34	[HEWLETT PACKARD]	LZB82550931	DZL211029
<b>J</b>	Printer	KX-P3200	[KME]	6BMDMA01003	ACJ5Z6KX-P3200
[Remotely Located Devices]					
<b>K</b>	Computer	PB600J	[Packard Bell]	T4944618600022	FOD4504x4A
<b>L</b>	CRT Display	D2825	[HEWLETT PACKARD]	MY74816611	JVP7154E
<b>M</b>	Keyboard	7150	[Packard Bell]	853180120	FOD4504x4A
<b>N</b>	Mouse	FDM-611	[Packard Bell]	TGMC52129769	F4Z4K3FDM-611

### 4.3 Cable(s) Used

The following cable(s) was used for the test.

Indication number in the following left side column corresponds to Section 4.1

No	Name	Length	Shield	Connector	Ferrite Core
1	Parallel Cable	2.0 m	Shielded	Metallic Hood	None
2	USB Cable	5.0 m	Shielded	Metallic Hood	None
3	Ethernet Cable	15 m	Shielded	Metallic Hood	None
4	Serial Cable	1.8 m	Shielded	Metallic Hood	None
5	CRT Display Cable	1.8 m	Shielded	Metallic Hood	None
6	Keyboard Cable	2.0 m	Shielded	Metallic Hood	None
7	Mouse Cable	2.0 m	Shielded	Metallic Hood	None
8	CRT Display Cable	1.4 m	Shielded	Metallic Hood	None
9	Keyboard Cable	1.3 m	Shielded	Metallic Hood	None
10	Mouse Cable	1.4 m	Shielded	Metallic Hood	None
11	AC Cord for Color Laser Printer	2.1 m	Unshielded	Plastic Hood	None
12	AC Cord for Serial Printer	2.1 m	Unshielded	Plastic Hood	None
13	AC Cord for Computer	2.1 m	Unshielded	Plastic Hood	None
14	AC Cord for CRT Display	2.1 m	Unshielded	Plastic Hood	None
15	AC Cord for Computer	2.1 m	Unshielded	Plastic Hood	None
16	AC Cord for CRT Display	2.1 m	Unshielded	Plastic Hood	None

### 4.4 Operating Conditions

Parallel / Ethernet Printing Mode (cycle time : 60 seconds)

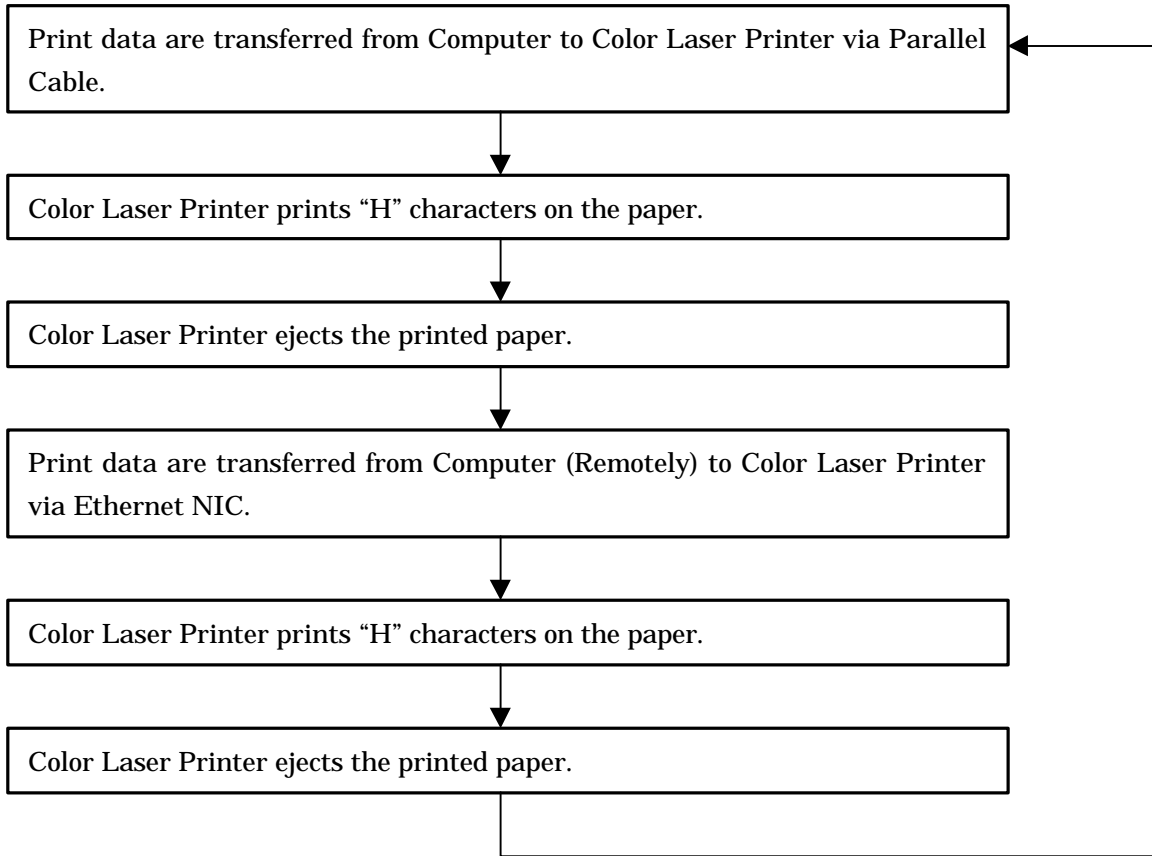

USB Printing Mode (cycle time : 30 seconds)

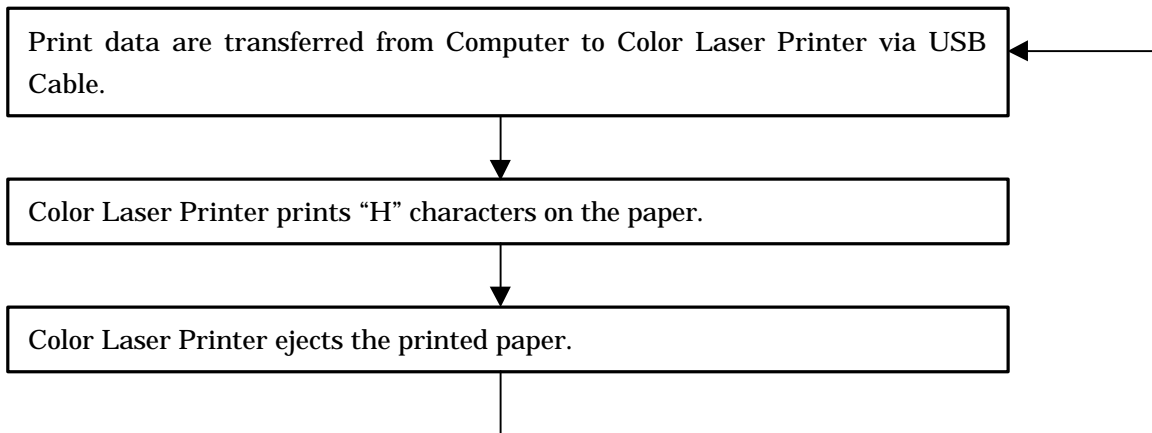

### 4.5 Any deviations from, additions to or exclusions from the test method

No deviation

## SECTION 5. PHOTOGRAPHS OF MAXIMUM EMISSION SET-UP

### 5.1 Radiated Emission

Test setup in accordance with ANSI C63.4 - 1992



(front view)

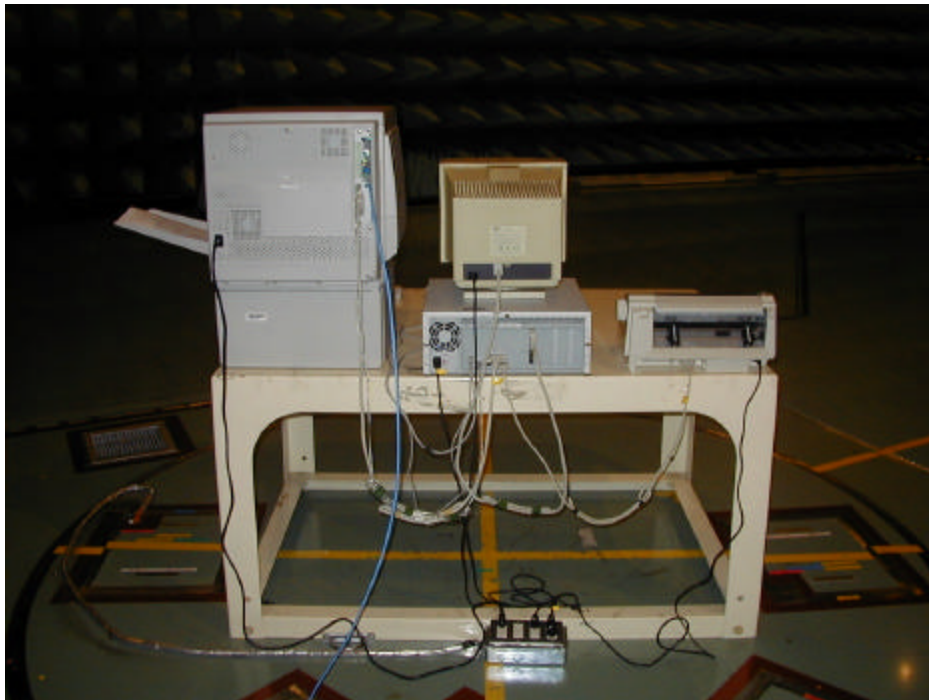

(rear view)

## 5.2 Conducted Emission

### Test setup in accordance with ANSI C63.4 - 1992



(front view)



(side view)

## SECTION 6. TEST ARRANGEMENT AND LIST OF TEST INSTRUMENTS

### 6.1 Radiated Emission

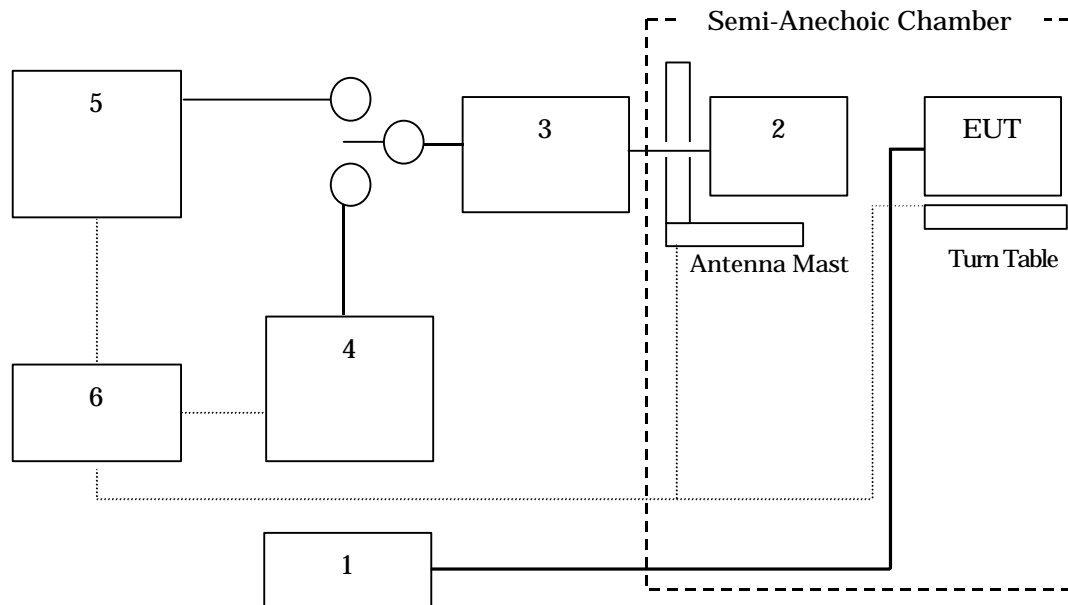

No	Apparatus	Model No. (Manufacture)	Specification	Calibration		Serial No.
				Date	Interval	
1	Power Supply	* FUK-23749-1 (NF)	50/60Hz 36kVA 264V	---	---	---
2	Antenna	* BBA9106 * UHALP9107 (Schwarzbeck) * 3115 (EMCO)	30M - 300MHz 300M - 1000MHz 1G - 18GHz	Oct-99 Oct-99 Apr-00	1 year 1 year 2 years	91031448 1729 4221
3	Pre-Amplifier	* 8447D * 8449B (HP)	0.1 - 1300MHz Gain >25dB 1G - 26.5GHz Gain >23dB	Oct-99 Jul-00	1 year 1 year	2944A08823 3008A01128
4	Spectrum Analyzer	* R3371A (Advantest)	100 - 26.5GHz	Oct-99	1 year	68630014
5	EMI Receiver	* ESVS10 (R&S)	20M - 1000MHz	Oct-99	1 year	844594/005
6	PC	PC340 (IBM)	---	---	---	---
-	Semi-Anechoic Chamber	* 3m method(NSA) (RIKEN)	30M - 1000MHz 1G - 18GHz	Sep-99	1 year	---
-	Cables	* EMF-174,175,176 * EMF-177,178,188 * EMF-195 * EMF-222	30M - 1000MHz 30M - 1000MHz 1G - 18GHz 1G - 18GHz	Nov-99 Nov-99 Jun-00 Jul-00	1 year 1 year 1 year 1 year	--- --- --- ---
-	SW Box	* PSU (R&S)	---	Nov-99	1 year	---

\* Used for final test

### 6.2 Conducted Emission

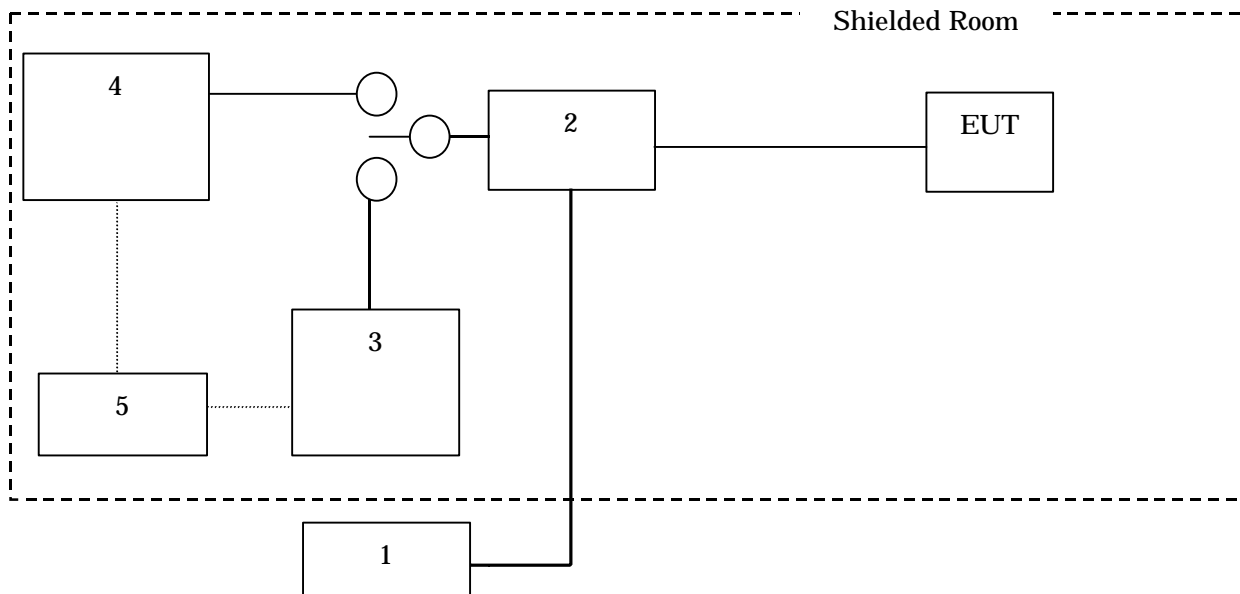

No	Apparatus	Model No. (Manufacture)	Specification	Calibration		Serial No.
				Date	Interval	
1	Power Supply	* FUK-23749-3 (NF)	50/60Hz 4kVA 264V	---	---	---
2	LISN	* KNW-407 (Kyoritsu)	250V15A	Oct-99	1 year	8-1345-3
3	Spectrum Analyzer	R3261C (Advantest)	9kHz - 2.6GHz	Nov-98	3 years	61720502
4	EMI Receiver	* ESHS10 (R&S)	9kHz - 30MHz	Oct-99	1 year	844077/017
5	PC	PC340 (IBM)	---	---	---	---
-	Shielded Room	* --- (RIKEN)	0.15M - 30MHz	---	---	---
-	R.F.Fuse	* MP612 (ANRITSU)	---	Oct-99	1 year	---
-	LISN	* KNW-407 (Kyoritsu)	250V15A	Sep-99	3 years	8-1345-4
-	50ohm Terminator	* ---	---	Jan-00	1 year	---
-	Cables	* EMF-164,165,167	0.15M - 30MHz	Oct-99	1 year	---
-	SW Box	* PSU (R&S)	---	Oct-99	1 year	---

\* Used for final test