

ELECTROMAGNETIC EMISSIONS
TEST REPORT

LD-00-F002 / FCC ID: ACJ4PKEFA14E28

EFA14E28: Warm 14W Globe CFL @ 60 kHz

EFA14E50: Cool 14W Globe CFL @ 60 kHz

EFD14E28: Warm 14W 3-Tube CFL @ 60 kHz

EFD14E50: Cool 14W 3-Tube CFL @ 60 kHz

FCC Part 18 : Consumer ISM equipment
Kind of equipment : Self ballasted fluorescent lamp
Model : EFA14E28
FCC ID : ACJ4PKEFA14E28

Matsushita EMC Center

Matsushita Electric Industrial Co., Ltd.

231-1 Yashiro, Sasayama
Hyogo 669-2356
JAPAN

TEL 0795-52-5681
FAX 0795-52-5682

This test report with appendix consists of 15 pages.

The test results only responds to the tested sample.

It is not allowed to copy this report even partly without the allowance of the test laboratory.

ENGINEERING TEST REPORT

This is to certify that the Self ballasted fluorescent lamp from which the following data have been derived through the required measurements, properly complies with the requirements of FCC Rules and Regulations Part 18 Subpart C & FCC/SOT MP-5 as of date of measurements were made.

1. Applicant : Matsushita Electric Industrial Co., Ltd
Address : 1006 Oaza Kadoma, Kadoma-city
Osaka, 571-8501, Japan
2. Factory : Matsushita Electronics Corporation
Address : 1-1 Saiwai-cho, Takatsuki-city
Osaka, 569-1193, Japan
3. Description of Device : Self ballasted fluorescent lamp "Panasonic".
 - a. Application Type : Certification
 - b. Model No. : EFA14E28
 - c. Serial No. : _____
 - d. Date of Manufacture : January, 2000
 - e. Oscillating Frequency : 60 ± 10 kHz
 - f. RF Power Output : 14W
 - g. Power Supply : AC 120V, 60Hz
 - h. EUT Conditions : Production (Client samples)
3. Measurement Procedures Used : FCC Method of Measurement of Radio Noise Emissions from ISM Devices, MP-5.
4. Measurement Site : Matsushita EMC Center
Matsushita Electric Industrial Co., Ltd.
5. Date of Measurement : January 21, 25, 2000

CERTIFYING ENGINEER

Katsuo Ishihara
Chief Engineer of
Matsushita EMC Center

Certification of Measurement Results

I hereby certify that this Self ballasted fluorescent lamp passed and give min. limit margins of 8.6 dB μ V/m(Vertical) at 33.244MHz at the Radiated Emissions and min. limit margins of 12.3 dB μ V(QP) at 0.533MHz at the Conducted Emissions with respect to the limits to which it was tested.

These test results are traceable to the National and International Standards.

Measurement Uncertainty, at time of test, and at least 95% confidence, was estimated to be as follows:

Radiated Emission Measurement	: 2.6 dB
Conducted Emission Measurement	: 3.1 dB

Certifying Engineer : Matsushita EMC Center

Katsuo Ishihara

Katsuo Ishihara
Chief Engineer of
Matsushita EMC Center

Description of Measurement Facility

NAME OF TEST SITE : Matsushita EMC Center

ADDRESS : 231-1 Yashiro, Sasayama
Hyogo 669-2356
JAPAN

APPROVAL : This site has been filed with FCC
FEDERAL COMMUNICATIONS COMMISSION
FCC File No. 31040/SIT-1300F2
(Refild date:August 28, 1997)

Accredited by NVLAP
National Institute of Standards and Technology
National Voluntary Laboratory Accrediation Program
NVLAP Lab Cord: 100428-0
(Effective through:December 31, 2000)

1. Field strength Limits. (§ 18.305(C))

a. Measurement Methods and Test Procedure

Methods of Measurements of Radio Noise Emissions from ISM

Equipment FCC/OST MP-5 (1985)

b. Test Arrangement

Above 30MHz, I used broad band antenna

Test Equipment Operation Mode: Quasi-Peak

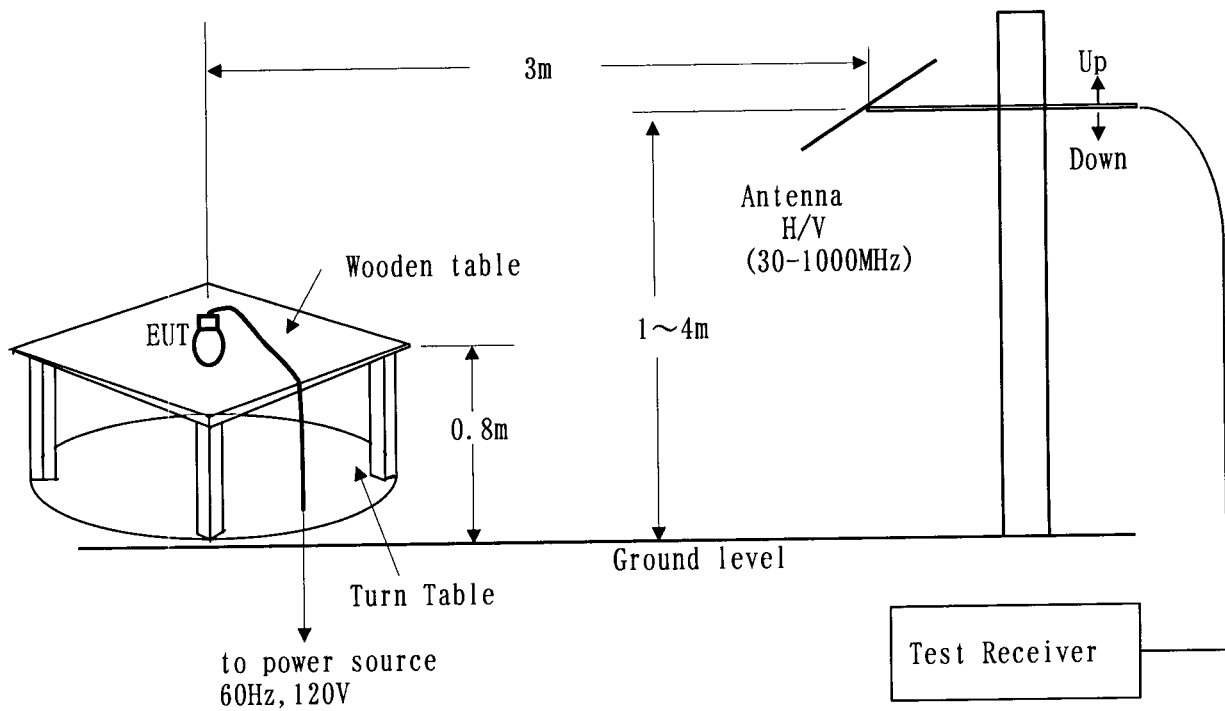

DESCRIPTION OF DEVICE
 Type of EUT : EFA14E28
 FCC ID : ACJ4PKEFA14E28

RADIATED RADIO NOISE MEASUREMENT
 TEST CONDITION OF INSTRUMENT

(1) Resolution Bandwidth : 120kHz
 (2) Detector Function : QP

EUT Warm-up Time : 30 minutes
 DATE : January 21, 2000
 Temp. : 10°C
 Humi. : 83%

Frequency (MHz)	Factor (dB)		Meter Reading at 3m (dB μ V/m)		Limits at 3m (μ V/m)	Emission Level at 3m (μ V/m)	
	Horizontal	Vertical	Horizontal	Vertical		Horizontal	Vertical
31.128	—	-7.2	—	36.3	100	—	28.5
32.184	—	-7.6	—	38.9	100	—	36.7
33.244	—	-8.0	—	39.4	100	—	37.2
43.052	—	-11.3	—	37.9	100	—	21.4
58.576	—	-16.5	—	35.0	100	—	8.4
65.028	—	-17.9	—	34.0	100	—	6.4
31.128	-7.2	—	23.9	—	100	6.8	—
32.184	-7.6	—	25.0	—	100	7.4	—
33.244	-8.0	—	25.4	—	100	7.4	—

FCC LIMITS Class B (§ 18.305(C))
 (Consumer equipment)

FREQUENCY (MHz)	LIMITS (μ V) : at 3m
30 - 88	100
88 - 216	150
216 - 1000	200

NOTE : Reporting frequency is the point measured more than 20dB from the limits in the emission level measurement from 30MHz to 1000MHz.

* Factor = Antenna Factor + Cable loss - AMP. Gain

DESCRIPTION OF DEVICE

Type of EUT : EFA14E28
 FCC ID : ACJ4PKEFA14E28

EUT Warm-up Time : 30 minutes

Test Result (Radiation Pattern)

DATE : January 21, 2000

Temp. : 10°C

Humi. : 83%

Measurement Frequency (MHz)	Orientation (Degree)	Meter Reading (dB μ V/m)	Factor (dB)	Field Strength (μ V/m)
33.244	0	39.4	-8.0	37.2
	20	38.9	-8.0	35.1
	40	39.1	-8.0	35.9
	60	38.4	-8.0	33.1
	80	38.4	-8.0	33.1
	100	38.3	-8.0	32.7
	120	38.3	-8.0	32.7
	140	38.1	-8.0	32.0
	160	38.2	-8.0	32.4
	180	38.3	-8.0	32.7
	200	37.8	-8.0	30.9
	220	37.8	-8.0	30.9
	240	38.0	-8.0	31.6
	260	38.6	-8.0	33.9
	280	38.1	-8.0	32.0
	300	38.9	-8.0	35.1
	320	38.9	-8.0	35.1
340	39.2	-8.0	36.3	

FCC LIMITS Class B (§18.305(C))
 (Consumer equipment)

FREQUENCY (MHz)
 30 - 88
 88 - 216
 216 - 1000

LIMITS (μ V):at 3m
 100
 150
 200

* Factor = Antenna Factor + Cable loss - AMP. Gain

1. Conduction Limits. (§ 18.307 (C))

a. Measurement Methods and Test Procedure

Methods of Measurements of Radio Noise Emissions from ISM

Equipment FCC/OST MP-5 (1985)

b. Test Arrangement

Test Equipment Operation Mode: Quasi-Peak

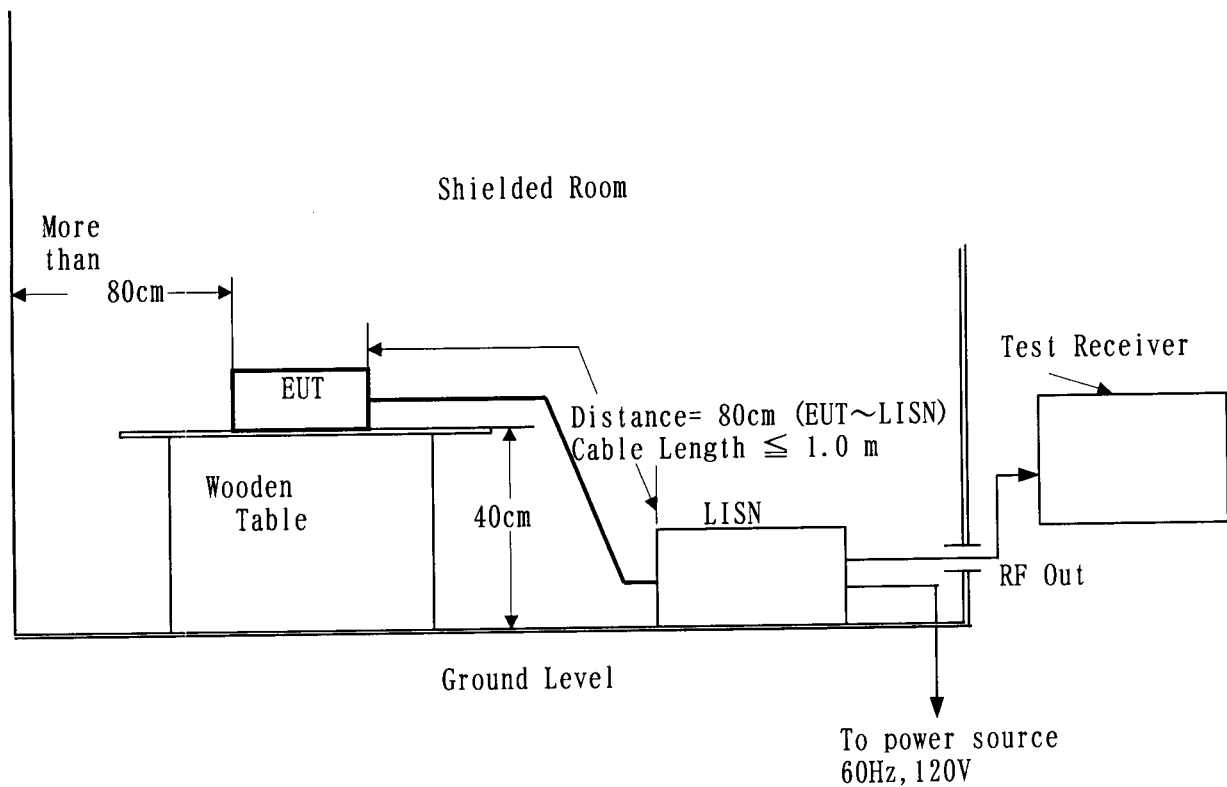

DESCRIPTION OF DEVICE

Type of EUT
FCC ID: EFA14E28
: ACJ4PKEFA14E28

Page 10 of 15

LINE CONDUCTED RF VOLTAGE MEASUREMENT
TEST CONDITION OF INSTRUMENT(1) Resolution Bandwidth : 9kHz
(2) Detector Function : QP

EUT Warm-up Time : 30 minutes

DATE : January 25, 2000

Temp.: 21°C

Humi.: 49%

Frequency (MHz)	LISN Factor (dB)	Meter Reading (dB μ V)		Limits (μ V)	Emission Level (μ V)	
		Other end- Ground	Other end- Ground		Other end- Ground	Other end- Ground
0.533	0.2	35.5	————	250	61.0	————
0.570	0.2	33.6	————	250	49.0	————
0.650	0.2	33.6	————	250	49.0	————
0.766	0.2	32.6	————	250	43.7	————
1.237	0.2	31.3	————	250	37.6	————
26.770	1.6	32.2	————	250	49.0	————

FREQUENCY (MHz)
0.45 ~ 30LIMITS (μ V)
250NOTE : Reporting frequency is the point measured more than 20dB from the limits
in the emission level measurement from 0.45MHz to 30MHz.

DESCRIPTION OF DEVICE

Type of EUT

: EFA14E28

FCC ID

: ACJ4PKEFA14E28

Page 11 of 15

LINE CONDUCTED RF VOLTAGE MEASUREMENT

EUT Warm-up Time : 30 minutes

TEST CONDITION OF INSTRUMENT

DATE : January 25, 2000

(1) Resolution Bandwidth : 9kHz

Temp.: 21°C

(2) Detector Function : QP

Humi.: 49%

Frequency (MHz)	LISN Factor (dB)	Meter Reading (dB μ V)		Limits (μ V)	Emission Level (μ V)	
		Other end- Ground	Other end- Ground		Other end- Ground	Other end- Ground
0.533	0.2	————	32.4	250	————	42.7
0.570	0.2	————	31.0	250	————	36.3
0.650	0.2	————	32.2	250	————	41.7
0.766	0.2	————	32.8	250	————	44.7
1.237	0.2	————	31.3	250	————	37.6
26.770	1.6	————	20.3	250	————	12.4

FREQUENCY (MHz)

0.45 ~ 30

LIMITS (μ V)

250

NOTE : Reporting frequency is the point measured more than 20dB from the limits
in the emission level measurement from 0.45MHz to 30MHz.