

FCC &ISED Radio Test Report

FCC ID: ACJ-SU-GX70
IC:216A-SUGX70

The report concerns: Original Grant

Report Reference No.....: 22EFSS10067 11221

Date Sample(s) Received.....: 2022-11-25

Date of Tested.....: From 2022-11-25 to 2022-12-25

Date of issue.....: 2022-12-25

Testing Laboratory: DongGuanShuoXin Electronic Technology Co., Ltd.
Zone A, 1F, No. 6, XinGang Road YuanGang Street,
Address: XinAn District, ChangAn Town, DongGuan City,
GuangDong, China

Applicant's name for FCC.....: Panasonic Corporation of North America

Address for FCC.....: Two Riverfront Plaza, 9th Floor, Newark, New
Jersey,07102-5490,United States

Applicant's name for IC.....: Panasonic Canada Inc.

Address for IC.....: 5770 Ambler Drive Mississauga ON L4W 2T3
Canada

Manufacturer.....: Panasonic Corporation

Equipment.....: Network Audio Amplifier

Trade Mark: Technics

Model: SU-GX70

Ratings: I/P: 120V~ 63W 60Hz

Test Engineer: 
Blue Qiu

Responsible Engineer : 
Smile Wang

Authorized Signatory: 
King Wang

Table of Contents

Page

1. TEST REPORT DECLARE	4
2. SUMMARY OF TEST RESULTS	5
2.1. MEASUREMENT UNCERTAINTY	6
3. GENERAL INFORMATION	7
3.1. GENERAL DESCRIPTION OF EUT	7
3.2. DESCRIPTION OF TEST MODES	9
3.3. PARAMETERS OF TEST SOFTWARE	9
3.4. BLOCK DIAGRAM SHOWING THE CONFIGURATION OF SYSTEM TESTED	10
3.5. SUPPORT UNITS	10
3.6. TEST ENVIRONMENT CONDITIONS	10
4. AC POWER LINE CONDUCTED EMISSIONS TEST	11
4.1. LIMIT	11
4.2. TEST PROCEDURE	11
4.3. MEASUREMENT INSTRUMENTS LIST	11
4.4. TESTSETUP	12
4.5. EUT OPERATING CONDITIONS	12
4.6. TEST RESULTS	13
5. RADIATED EMISSION TEST	15
5.1. LIMIT	15
5.2. TEST PROCEDURE	16
5.3. MEASUREMENT INSTRUMENTS LIST	17
5.4. TESTSETUP	17
5.5. EUT OPERATING CONDITIONS	18
5.6. TEST RESULT- 9KHZ TO 30MHZ	19
5.7. TEST RESULT- 30MHZ TO 1000MHZ	20
5.8. TEST RESULT- ABOVE 1000MHZ(BAND EDGE)	22
5.9. TEST RESULTS - ABOVE 1000MHZ(HARMONIC)	30
6. BANDWIDTH TEST	42
6.1. LIMIT	42
6.2. TEST PROCEDURE AND SETTING	42
6.3. MEASUREMENT INSTRUMENTS LIST	42
6.4. TEST SETUP	42
6.5. EUT OPERATION CONDITIONS	42

Table of Contents	Page
6.6. TESTRESULTS	43
7. MAXIMUM OUTPUT POWER	45
7.1. LIMIT	45
7.2. TEST PROCEDURE	45
7.3. MEASUREMENT INSTRUMENTS LIST	45
7.4. TEST SETUP	45
7.5. EUT OPERATION CONDITIONS	45
7.6. TESTRESULTS	46
8. CONDUCTED SPURIOUS EMISSION	47
8.1. LIMIT	47
8.2. TEST PROCEDURE	47
8.3. MEASUREMENT INSTRUMENTS LIST	47
8.4. TEST SETUP	47
8.5. EUT OPERATION CONDITIONS	47
8.6. TEST RESULTS	48
9. POWER SPECTRAL DENSITY TEST	50
9.1. LIMIT	50
9.2. TEST PROCEDURE	50
9.3. MEASUREMENT INSTRUMENTS LIST	50
9.4. TEST SETUP	50
9.5. EUT OPERATION CONDITIONS	50
9.6. TEST RESULTS	51
10. FREQUENCY STABILITY MEASUREMENT	52
10.1. LIMIT	52
10.2. TEST PROCEDURE	52
10.3. MEASUREMENT INSTRUMENTS LIST	52
10.4. TEST SETUP	52
10.5. EUT OPERATION CONDITIONS	52
10.6. TEST RESULTS	53

1 TEST REPORT DECLARE

Applicant for FCC	Panasonic Corporation of North America
Address for FCC	Two Riverfront Plaza, 9th Floor, Newark, New Jersey,07102-5490,United States
Applicant for IC	Panasonic Canada Inc.
Address for IC	5770 Ambler Drive Mississauga ON L4W 2T3 Canada
Manufacturer	Panasonic Corporation
Address	1006, Oaza Kadoma, kadoma-shi, Osaka, 571-8501, Japan
Factory	Panasonic AVC Networks Johor Malaysia
Address	IE,PLO 460, Jalan Bandar, 81700 Pasir Gudang, Johor, Malaysia
Equipment	Network Audio Amplifier
Model No.	SU-GX70
Trade Mark	Technics
Standard	FCC Part15, Subpart C (15.247) RSS-247 Issue 2, Feb. 2017 RSS-Gen Issue 5, Mar. 2019 ANSI C63.10-2013

We Declare:

The equipment described above is tested by DongGuanShuoXin Electronic Technology Co., Ltd(ATT). and in the configuration tested the equipment complied with the standards specified above. The test results are contained in this test report and DongGuanShuoXin Electronic Technology Co., Ltd.(ATT) is assumed of full responsibility for the accuracy and completeness of these tests.

ATT is not responsible for the sampling stage, so the results only apply to the sample as received.

ATT's reports apply only to the specific samples tested under conditions. It is manufacture's responsibility to ensure that additional production units of this model are manufactured with the identical electrical and mechanical components. ATT shall have no liability for any declarations, inferences or generalizations drawn by the client or others from ATT issued reports.

2 SUMMARY OF TEST RESULTS

The EUT have been tested according to the applicable standards as referenced below:

Standard(s) Section		Test Item	Judgment	Remark
FCC	ISED			
15.207	RSS-Gen8.8	AC Power Line Conducted Emissions	PASS	-----
15.247(d) 15.205(a) 15.209(a)	RSS-247 5.5 RSS-Gen8.9 RSS-Gen8.10	Radiated Emissions	PASS	-----
15.247(a)(2)	RSS-247 5.2 (a) RSS-Gen6.7	Bandwidth	PASS	-----
15.247(b)(3)	RSS-247 5.4 (d)	Maximum Output Power	PASS	-----
15.247(d)	RSS-247 5.5	ConductedSpurious Emission	PASS	-----
15.247(e)	RSS-247 5.2 (b)	Power Spectral Density	PASS	-----
-	RSS-Gen 6.11	Frequency Stability	PASS	-----
15.203	-	Antenna Requirement	PASS	Note(2)

Note:

- (1) "N/A" denotes test is not applicable to this device.
- (2) The device what use a permanently attached antenna were considered sufficient tocomply with the provisions of 15.203.

2.1 MEASUREMENT UNCERTAINTY

Test Item	Uncertainty
Uncertainty for Conductionemission test (9kHz-150kHz)	3.7 dB
Uncertainty for Conduction emission test (150kHz-30MHz)	3.3 dB
Uncertainty for Radiation Emission test (30MHz-200MHz)	4.60 dB (Polarize: V)
	4.60 dB (Polarize: H)
Uncertainty for Radiation Emission test (200MHz-1GHz)	6.10 dB (Polarize: V)
	5.08 dB (Polarize: H)
Uncertainty for Radiation Emission test (1GHz-6GHz)	5.01 dB (Polarize: V)
	5.01 dB (Polarize: H)
Uncertainty for Radiation Emission test (6GHz-18GHz)	5.26 dB (Polarize: V)
	5.26 dB (Polarize: H)
Uncertainty for Radiation Emission test (18GHz-40GHz)	5.06 dB (Polarize: V)
	5.06 dB (Polarize: H)
Uncertainty for radio frequency	±0.048kHz
Uncertainty for conducted RF Power	±0.32dB

Note:

This uncertainty represents an expanded uncertainty expressed at approximately the 95%confidence level using a coverage factor of k=2.

Test Facility:

The Test site used by DongGuanShuoXin Electronic Technology Co., Ltd. to collect test data is located on the Zone A, 1F, No. 6, XinGang Road YuanGang Street, XinAn District, ChangAn Town, DongGuan City, GuangDong, China

The test facility is recognized, certified, or accredited by the following organizations:

Item	Registration No.	Expiration Date
CNAS	L3098	2024-08-27
A2LA	4893.01	2024-06-30
Innovation, Science and Economic Development Canada (ISED)	11033A CAB identifier:CN0083	2024-06-30
Federal Communications Commission (FCC)	171688 Designation No.:CN1235	2024-06-30

3 GENERAL INFORMATION

3.1 GENERAL DESCRIPTION OF EUT

Equipment	Network Audio Amplifier	
Brand Name	Technics	
Test Model	SU-GX70	
Series Model	N/A	
Model Difference(s)	N/A	
Hardware Version	PR	
Software Version	22.02	
PowerSource	AC Mains	
Power Rating	120V~ 63W 60Hz	
Operation Frequency	2402 MHz ~ 2480 MHz	
Modulation Technology	GFSK	
Bit Rate of Transmitter	1Mbps /2Mbps	
Antenna Information	Antenna Type:PCB	Maximum Peak Gain:1.69dBi
Max. Output Power	8.553dBm(0.00717W)1Mbps 8.586dBm(0.00722W) 2Mbps	

Note:

1. For a more detailed features description, please refer to the manufacturer's specifications or the user's manual.

2. Channel List:

Channel	Frequency (MHz)	Channel	Frequency (MHz)
00	2402	20	2442
01	2404	21	2444
02	2406	22	2446
03	2408	23	2448
04	2410	24	2450
05	2412	25	2452
06	2414	26	2454
07	2416	27	2456
08	2418	28	2458
09	2420	29	2460
10	2422	30	2462
11	2424	31	2464
12	2426	32	2466
13	2428	33	2468
14	2430	34	2470
15	2432	35	2472
16	2434	36	2474
17	2436	37	2476
18	2438	38	2478
19	2440	39	2480

3.2 DESCRIPTION OF TEST MODES

The test system was pre-tested based on the consideration of all possible combinations of EUT operation mode.

Pretest Mode	Description
Mode 1	BLE 1M TX Mode NOTE (1)
Mode 2	BLE 2M TX Mode NOTE (1)
Mode 3	BLE 2M TX Mode Channel 39

Following mode(s) as (were) found to be the worst case(s) and selected for the final test.

AC power line conducted emissions test	
Final Test Mode	Description
Mode 3	BLE 2M TX Mode Channel 39

Radiated emissions test - Below 1GHz	
Final Test Mode	Description
Mode 3	BLE 2M TX Mode Channel 39

Radiated emissions test - Above 1GHz	
Final Test Mode	Description
Mode 1	BLE M TX Mode NOTE (1)
Mode 2	BLE 2M TX Mode NOTE (1)

Conducted test	
Final Test Mode	Description
Mode 1	BLE 1M TX Mode NOTE (1)
Mode 2	BLE 2M TX Mode NOTE (1)

Note:

(1) The measurements are performed at the high, middle, low available channels.

3.3 PARAMETERS OF TEST SOFTWARE

During testing channel & power controlling software provided by the customer was used to control the operating channel as well as the output power level. The RF output power selection is for the setting of RF output power expected by the customer and is going to be fixed on the firmware of the final end product power parameters of BT LE

Test Software	N/A		
Frequency (MHz)	2402	2440	2480
Parameters-1Mbps	Default	Default	Default
Parameters-2Mbps	Default	Default	Default

3.4 BLOCK DIAGRAM SHOWING THE CONFIGURATION OF SYSTEM TESTED

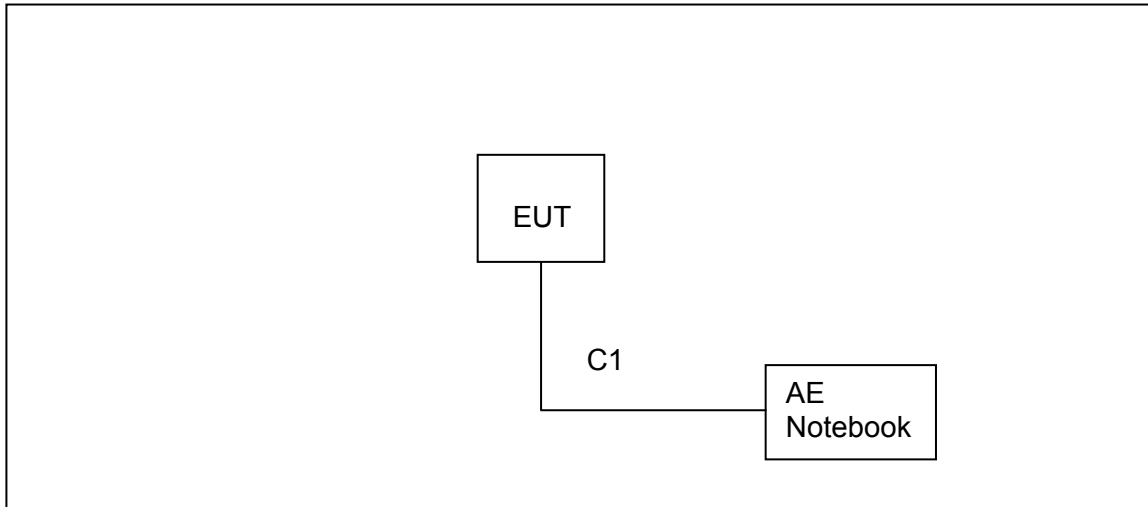

3.5 SUPPORT UNITS

Item	Equipment	Brand	Model No.	Series No.
AE	Notebook	Lenovo	/	/

Item	Cable Type	Shielded Type	Ferrite Core	Length
C1	DC Cable	NO	NO	0.8m

3.6 TEST ENVIRONMENT CONDITIONS

Test Item	Temperature	Humidity	Test Voltage
AC Power Line Conducted Emissions	23.1°C	52%	AC120V
Radiated Emissions-9K-30MHz	22°C	60%	AC120V
Radiated Emissions-30 MHz to 1GHz	23°C	54%	AC120V
Radiated Emissions-Above 1000 MHz	23°C	54%	AC120V
Bandwidth	20.6°C	51%	AC120V
Maximum Output Power	20.6°C	51%	AC120V
ConductedSpurious Emission	20.6°C	51%	AC120V
Power Spectral Density	20.6°C	51%	AC120V

4 AC POWER LINE CONDUCTED EMISSIONS TEST

4.1 LIMIT

Frequency of Emission (MHz)	Limit (dB μ V)	
	Quasi-peak	Average
0.15 -0.50	66 to 56*	56 to 46*
0.50 -5.0	56	46
5.0 -30.0	60	50

Note:

- (1) The tighter limit applies at the band edges.
- (2) The limit of " * " marked band means the limitation decreases linearly with the logarithm of the frequency in the range.

The following table is the setting of the receiver

Receiver Parameters	Setting
Attenuation	10 dB
Start Frequency	0.15 MHz
Stop Frequency	30 MHz
IF Bandwidth	9 kHz

4.2 TEST PROCEDURE

- a. The EUT was placed 0.8 meters from the horizontal ground plane with EUT being connected to the power mains through a line impedance stabilization network (LISN). All other support equipment powered from additional LISN(s). The LISN provide 50 Ohm/ 50uH of coupling impedance for the measuring instrument.
- b. Interconnecting cables that hang closer than 40 cm to the groundplane shall be folded back and forth in the center forming a bundle 30 to 40 cm long.
- c. I/O cables that are not connected to a peripheral shall be bundled in the center. The end of the cable may be terminated, if required, using the correct terminating impedance. The overall length shall not exceed 1 m.
- d. LISN at least 80 cm from nearest part of EUT chassis.

4.3 MEASUREMENT INSTRUMENTS LIST

Item	Kind of Equipment	Manufacturer	Type No.	Serial No.	Calibrated until
1	Pulse Limiter	MTS-systemtechnik	MTS-IMP-136	261115-010-0024	12/11/2023
2	EMI Test Receiver	R&S	ESCI	101308	12/12/2023
3	LISN	AFJ	LS16	16011103219	05/26/2023
4	LISN	Schwarzbeck	NSLK 8127	8127-432	12/11/2022
5	Measurement Software	Farad	EZ-EMC (Ver.ATT-03A)	N/A	N/A

4.4 TESTSETUP

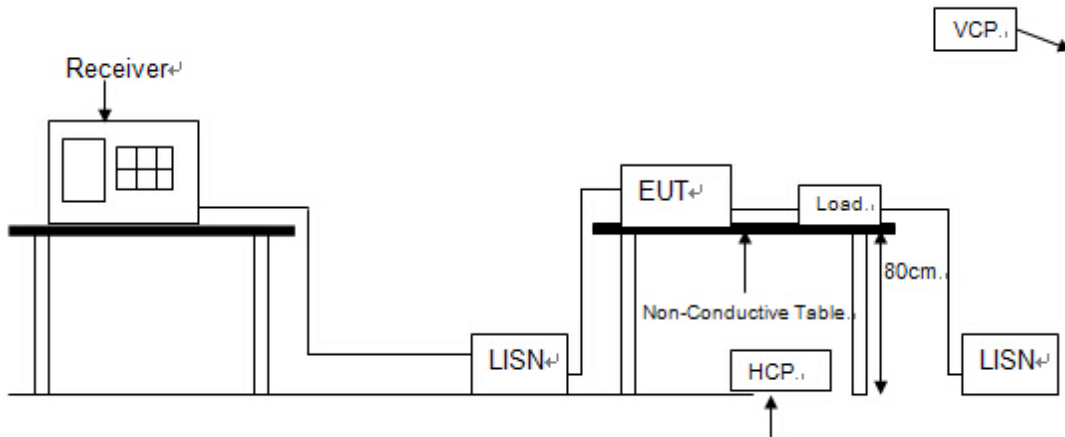

4.5 EUT OPERATING CONDITIONS

The EUT was configured for testing in a typical fashion (as a customer would normally use it). The EUT has been programmed to continuously transmit during test. This operating condition was tested and used to collect the included data.

4.6 TEST RESULTS

Test Mode: BLE 2M TX Mode Channel 39

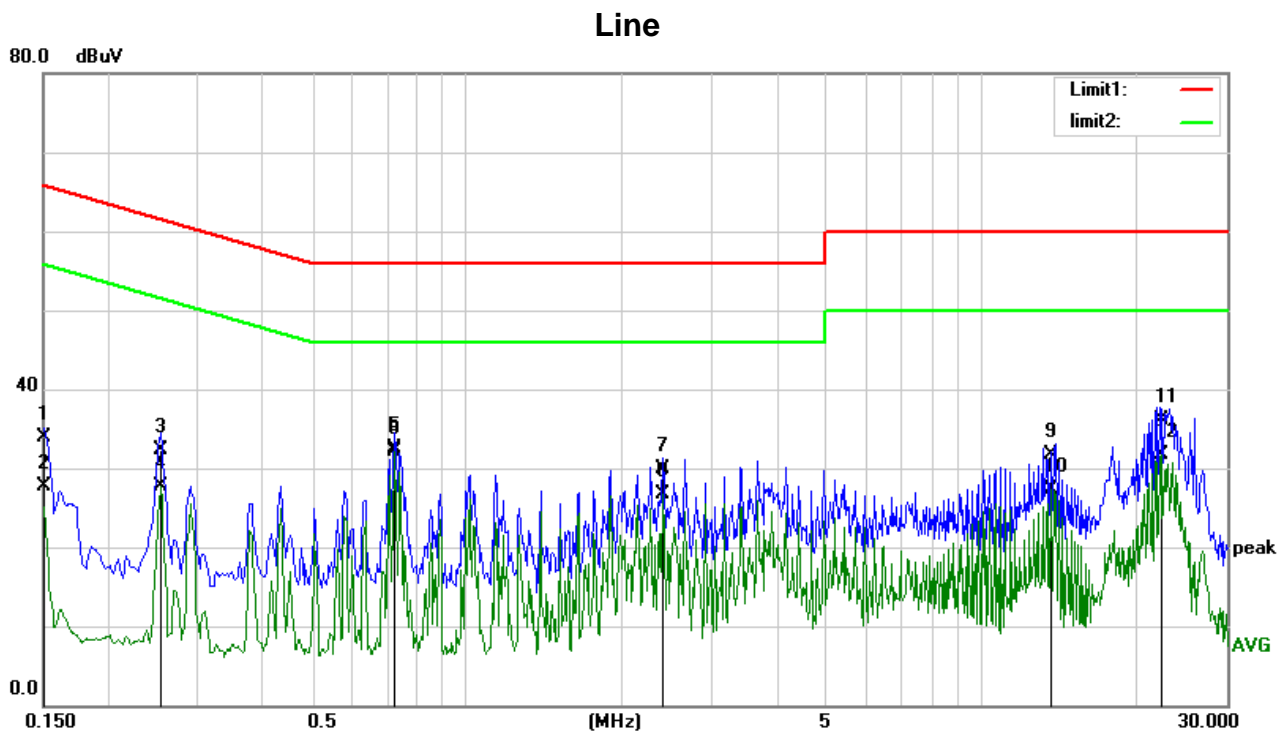

No.	Frequency (MHz)	Reading (dBuV)	Correct Factor(dB)	Result (dBuV)	Limit (dBuV)	Margin (dB)	Remark
1	0.1500	23.18	10.72	33.90	65.99	-32.09	QP
2	0.1500	16.90	10.72	27.62	55.99	-28.37	AVG
3	0.2540	21.75	10.62	32.37	61.62	-29.25	QP
4	0.2540	16.99	10.62	27.61	51.62	-24.01	AVG
5	0.7260	21.76	10.73	32.49	56.00	-23.51	QP
6	0.7260	21.41	10.73	32.14	46.00	-13.86	AVG
7	2.4020	19.08	10.79	29.87	56.00	-26.13	QP
8	2.4020	15.96	10.79	26.75	46.00	-19.25	AVG
9	13.6620	21.05	10.75	31.80	60.00	-28.20	QP
10	13.6620	16.64	10.75	27.39	50.00	-22.61	AVG
11	22.5180	25.46	10.68	36.14	60.00	-23.86	QP
12	22.5180	20.98	10.68	31.66	50.00	-18.34	AVG

Remarks:

- (1) Measurement Value = Reading Level + Correct Factor.
- (2) Margin Level = Measurement Value - Limit Value.

Test Mode: BLE 2M TX Mode Channel 39

Neutral

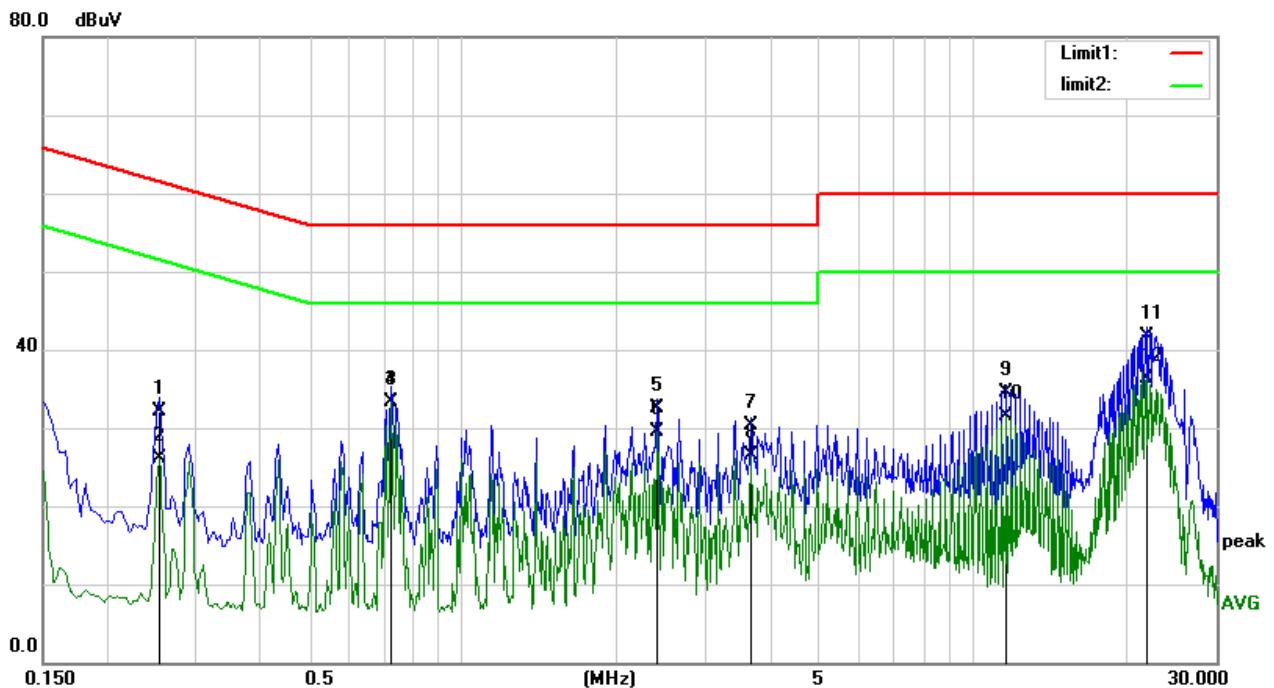

No.	Frequency (MHz)	Reading (dBuV)	Correct Factor(dB)	Result (dBuV)	Limit (dBuV)	Margin (dB)	Remark
1	0.2540	21.51	10.62	32.13	61.62	-29.49	QP
2	0.2540	15.47	10.62	26.09	51.62	-25.53	AVG
3	0.7260	22.65	10.73	33.38	56.00	-22.62	QP
4	0.7260	22.51	10.73	33.24	46.00	-12.76	AVG
5	2.4060	21.79	10.79	32.58	56.00	-23.42	QP
6	2.4060	18.66	10.79	29.45	46.00	-16.55	AVG
7	3.6700	19.54	10.72	30.26	56.00	-25.74	QP
8	3.6700	15.69	10.72	26.41	46.00	-19.59	AVG
9	11.6420	23.71	10.75	34.46	60.00	-25.54	QP
10	11.6420	20.79	10.75	31.54	50.00	-18.46	AVG
11	22.0180	30.98	10.69	41.67	60.00	-18.33	QP
12	22.0180	25.69	10.69	36.38	50.00	-13.62	AVG

Remarks:

(1) Measurement Value = Reading Level + Correct Factor.

(2) Margin Level = Measurement Value - Limit Value.

5 RADIATED EMISSION TEST

5.1 LIMIT

In case the emission fall within the restricted band specified on 15.205(a) and RSS-Gen 8.10, then the 15.209(a) and RSS-Gen 8.9 limit in the table below has to be followed.

LIMITS OF RADIATED EMISSION MEASUREMENT (9 kHz-1000MHz)

Frequency (MHz)	Field Strength (microvolts/meter)	Measurement Distance (meters)
0.009-0.490	2400/F(kHz)	300
0.490-1.705	24000/F(kHz)	30
1.705-30.0	30	30
30-88	100	3
88-216	150	3
216-960	200	3
Above 960	500	3

LIMITS OF RADIATED EMISSION MEASUREMENT (9 kHz-30 MHz)

Frequency (MHz)	Magnetic field strength (H-Field) (μA/m)	Measurement Distance (meters)
0.009-0.490	6.37/F(kHz)	300
0.490-1.705	6.37/F(kHz)	30
1.705-30.0	0.08	30

LIMITS OF RADIATED EMISSION MEASUREMENT (30 MHz-1000MHz)

Frequency (MHz)	Field Strength (μV/m at 3m)
30-88	100
88-216	150
216-960	200
Above 960	500

LIMITS OF RADIATED EMISSION MEASUREMENT (Above 1000MHz)

Frequency (MHz)	(dBuV/m at 3 m)	
	Peak	Average
Above 1000	74	54

Note:

- (1) The limit for radiated test was performed according to FCC PART 15C and RSS-247.
- (2) The tighter limit applies at the band edges.
- (3) Emission level (dBuV/m)=20log Emission level (uV/m).

5.2 TEST PROCEDURE

- a. The measuring distance of 3 m shall be used for measurements. The EUT was placed on the top of a rotating table 0.8 meter above the ground at a 3 meter semi-anechoic chamber. The table was rotated 360 degrees to determine the position of the highest radiation.(below 1GHz)
- b. The measuring distance of 3 m or 1.5m shall be used for measurements. The EUT was placed on the top of a rotating table 1.5 meter above the ground at a 3 meter semi-anechoic chamber. The table was rotated 360 degrees to determine the position of the highest radiation.(above 1GHz)
- c. The height of the equipment or of the substitution antenna shall be 0.8m or 1.5m; the height of the test antenna shall vary between 1 m to 4 m. Both horizontal and vertical polarizations of the antenna are set to make the measurement.
- d. For each suspected emission, the EUT was arranged to its worst case and then the antenna was tuned to heights find the maximum reading (used Bore sight function).
- e. The receiver system was set to peak and average detect function and specified bandwidth with maximum hold mode when the test frequency is above 1GHz.
- f. The initial step in collecting radiated emission data is a receiver peak detector mode pre-scanning the measurement frequency range. Significant peaks are then marked and then Quasi Peak detector mode re-measured.
- g. All readings are Peak unless otherwise stated QP in column of Note. Peak denotes that the Peak reading compliance with the QP Limits and then QP Mode measurement didn't perform. (below 1GHz)
- h. All readings are Peak Mode value unless otherwise stated AVG in column of Note. If the Peak Mode Measured value compliance with the Peak Limits and lower than AVG Limits, the EUT shall be deemed to meet both Peak & AVG Limits and then only Peak Mode was measured, but AVG Mode didn't perform. (above 1GHz)
- i. The test result is calculated as the following:
 - (1) Result = Reading + Correct Factor
 - (2) Correct Factor = Antenna Factor + Cable Loss – Amplifier Gain + Attenuator
 - (3) Margin = Result - Limit

Spectrum Parameter	Setting
Attenuation	Auto
Start Frequency	1000 MHz
Stop Frequency	10th carrier harmonic
RBW / VBW (Emission in restricted band)	RBW 1MHz VBW 3MHz peak detector for Pk value RMS detector for AV value

Receiver Parameter	Setting
Attenuation	Auto
Start ~ Stop Frequency	9 kHz~90 kHz for PK/AVG detector
Start ~ Stop Frequency	90 kHz~110 kHz for QP detector
Start ~ Stop Frequency	110 kHz~490 kHz for PK/AVG detector
Start ~ Stop Frequency	490 kHz~30 MHz for QP detector
Start ~ Stop Frequency	30MHz~1000MHz for QP detector

5.3 MEASUREMENT INSTRUMENTS LIST

Item	Equipment	Manufacturer	Model No.	Serial No.	Calibrated until
1	EMI Test Receiver	R&S	ESCI	101307	12/11/2023
2	Spectrum Analyzer	Agilent	E4407B	US40240708	11/10/2023
3	Loop antenna	SCHWARZBECK K	FMZB1519	1519-062	01/15/2024
4	Broadband antenna	SCHWARZBECK	VULB9168	VULB9168-192	07/04/2023
5	HORN ANTENNA	SCHWARZBECK	BBHA9120D	9120D 1065	04/18/2023
6	Preamplifier Amplifier	HP	8447F	3113A05680	12/19/2023
7	PRE-AMPLIFIER	CY	EMC011830	980136	04/18/2023
8	RF Cable	R&S	Test Cable 4	4	12/11/2023
9	RF Cable	R&S	Test Cable 5	5	12/11/2023
10	RF Cable	R&S	Test Cable 9	9	04/18/2023
11	RF Cable	R&S	Test Cable 10	10	04/18/2023
12	Measurement Software	Farad	EZ-EMC (Ver.ATT-03A)	N/A	N/A

5.4 TESTSETUP

9 kHz-30 MHz

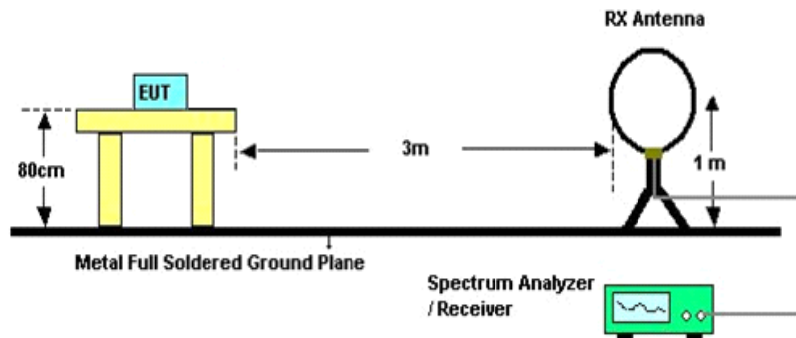

30 MHz to 1 GHz

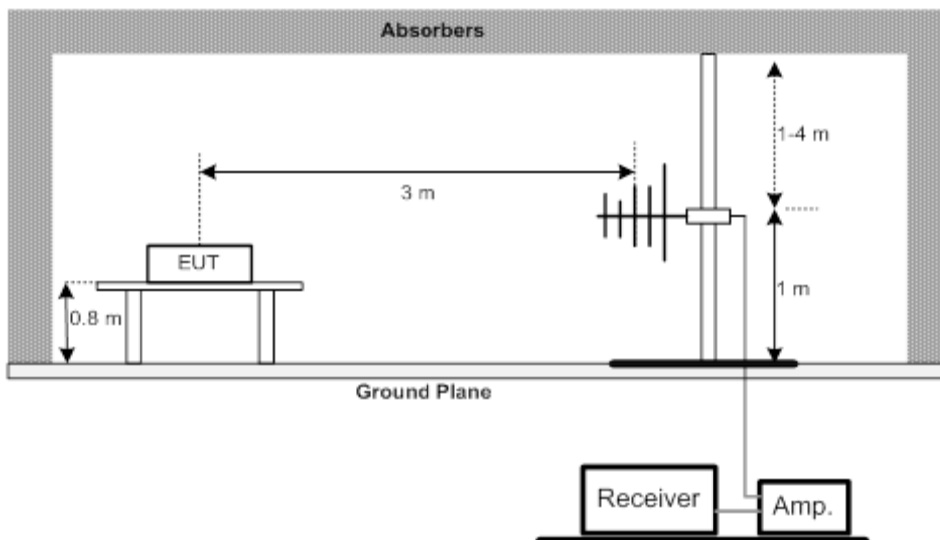

Above 1 GHz

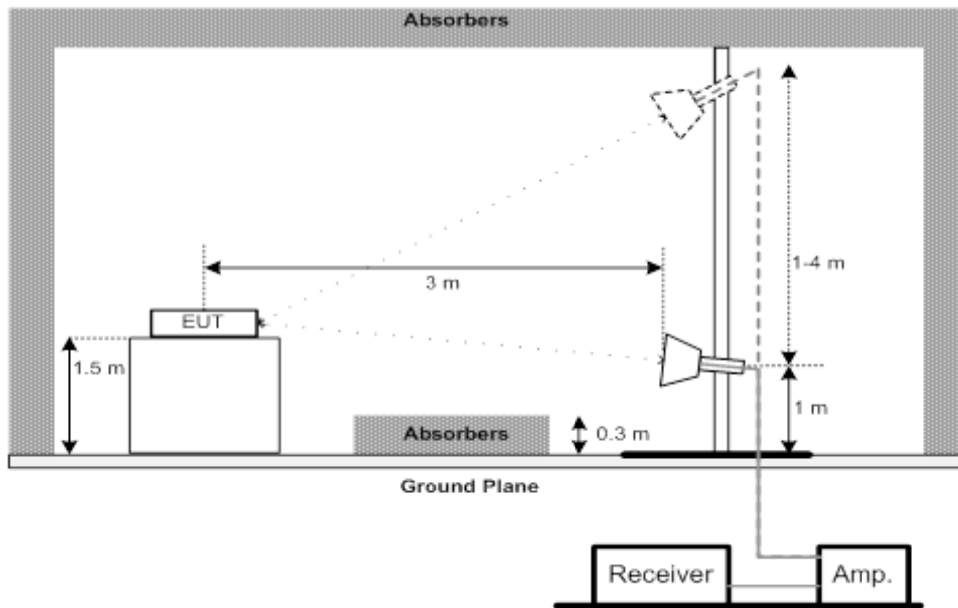

5.5 EUT OPERATING CONDITIONS

The EUT was programmed to be in continuously transmitting mode.

5.6 TEST RESULT- 9kHz TO 30MHz

Test Mode:	BLE 2M TX Mode Channel 39
------------	---------------------------

Freq. (MHz)	Reading (dBuV/m)	Limit (dBuV/m)	Margin (dB)	State P/F
--	--	--	--	P
--	--	--	--	P

Note:

The amplitude of spurious emissions which are attenuated by more than 20dB below the permissible value has no need to be reported.

Distance extrapolation factor = $20 \log (\text{specific distance}/\text{test distance})(\text{dB})$;

Limit line = specific limits(dBuv) + distance extrapolation factor

5.7 TEST RESULT- 30MHz TO 1000MHz

Test Mode : BLE 2M TX Mode Channel 39

Vertical

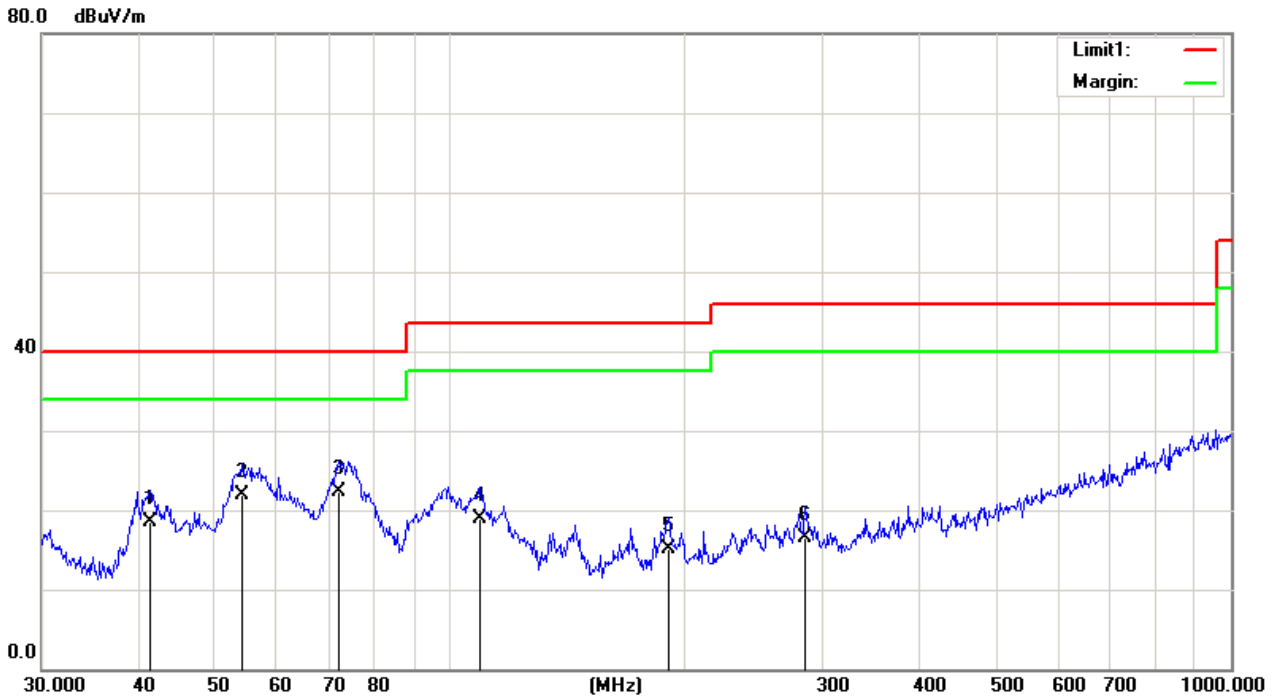

No. Mk.	Freq.	Reading Level	Correct Factor	Measurement	Limit	Over	Antenna Height	Table Degree		
	MHz	dBuV	dB	dBuV/m	dB/m	dB	cm	degree	Detector	Comment
1	41.2765	31.56	-13.14	18.42	40.00	-21.58	300	289	QP	
2	54.0711	34.55	-12.66	21.89	40.00	-18.11	100	157	QP	
3 *	72.0843	36.98	-14.77	22.21	40.00	-17.79	200	124	QP	
4	109.0286	33.16	-14.28	18.88	43.50	-24.62	200	92	QP	
5	190.4050	26.59	-11.40	15.19	43.50	-28.31	100	75	QP	
6	284.9767	24.47	-7.99	16.48	46.00	-29.52	100	64	QP	

*:Maximum data x:Over limit !:over margin

(Reference Only)

Test Mode : BLE 2M TX Mode Channel 39

Horizontal

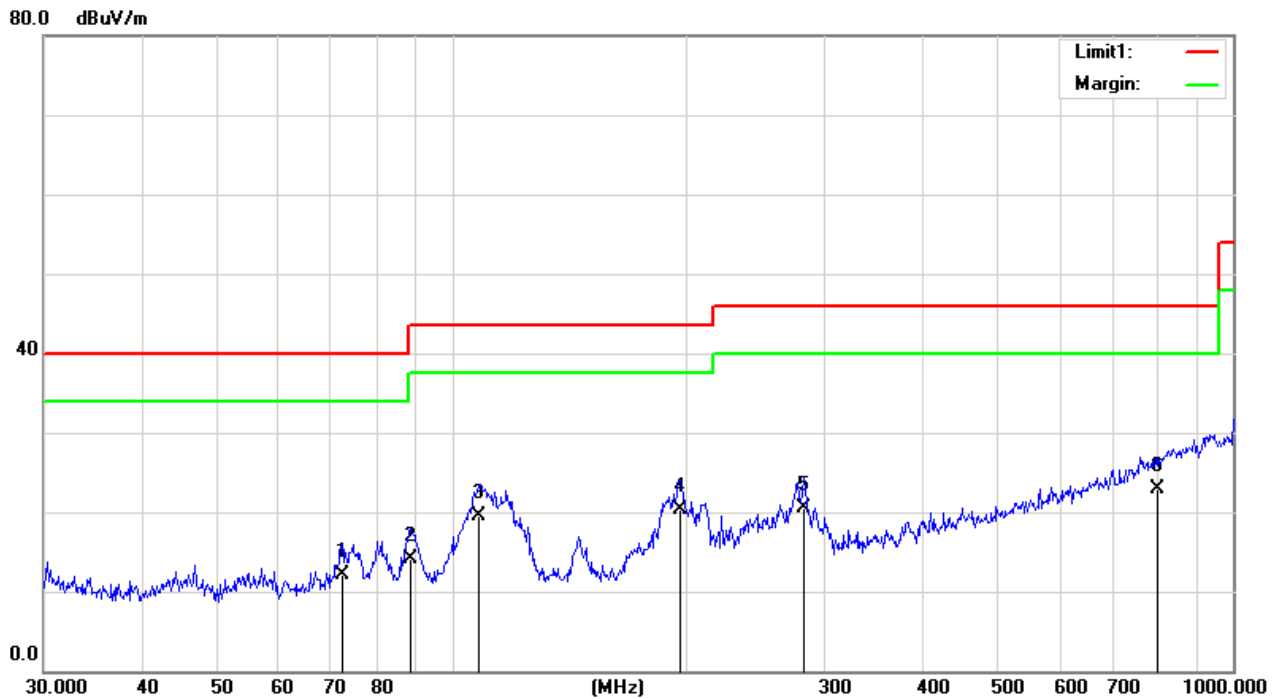

No.	Mk.	Freq. MHz	Reading Level dBuV	Correct Factor dB	Measure- ment dBuV/m	Limit dB/m	Over dB	Detector	Antenna Height cm	Table Degree	Comment
1		72.3376	28.38	-16.24	12.14	40.00	-27.86	QP	200	241	
2		88.3421	31.35	-17.22	14.13	43.50	-29.37	QP	300	16	
3		108.2667	34.24	-14.73	19.51	43.50	-23.99	QP	100	341	
4		195.8220	29.91	-9.60	20.31	43.50	-23.19	QP	100	222	
5		281.9946	26.73	-6.22	20.51	46.00	-25.49	QP	100	160	
6	*	798.9797	22.15	0.79	22.94	46.00	-23.06	QP	200	49	

*:Maximum data x:Over limit !:over margin

⟨Reference Only

5.8 TEST RESULT- ABOVE 1000MHz(BAND EDGE)

Test Mode: TX 2402 MHz_CH00_1Mbps

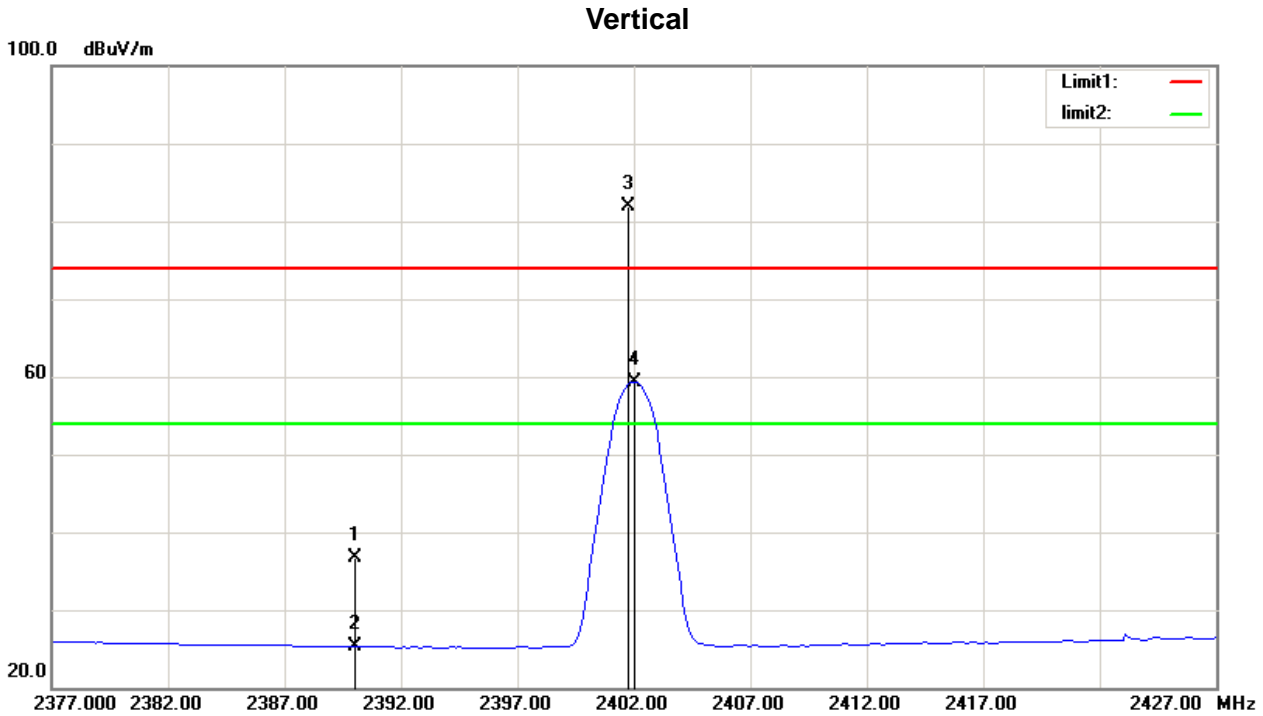

No.	Mk.	Freq.	Reading Level	Correct Factor	Measurement	Limit	Over	Antenna Height	Table Degree	
		MHz	dBuV	dB	dBuV/m	dB/m	dB	cm	degree	Comment
1		2390.000	48.75	-12.02	36.73	74.00	-37.27	peak	150	304
2		2390.000	37.28	-12.02	25.26	54.00	-28.74	AVG	150	304
3	*	2401.750	93.96	-11.99	81.97	74.00	7.97	peak	150	304 NO LIMIT
4	X	2402.000	71.36	-11.98	59.38	54.00	5.38	AVG	150	304 NO LIMIT

*:Maximum data x:Over limit !:over margin

⟨Reference Only

Test Mode: TX 2402 MHz_CH00_1Mbps

Horizontal

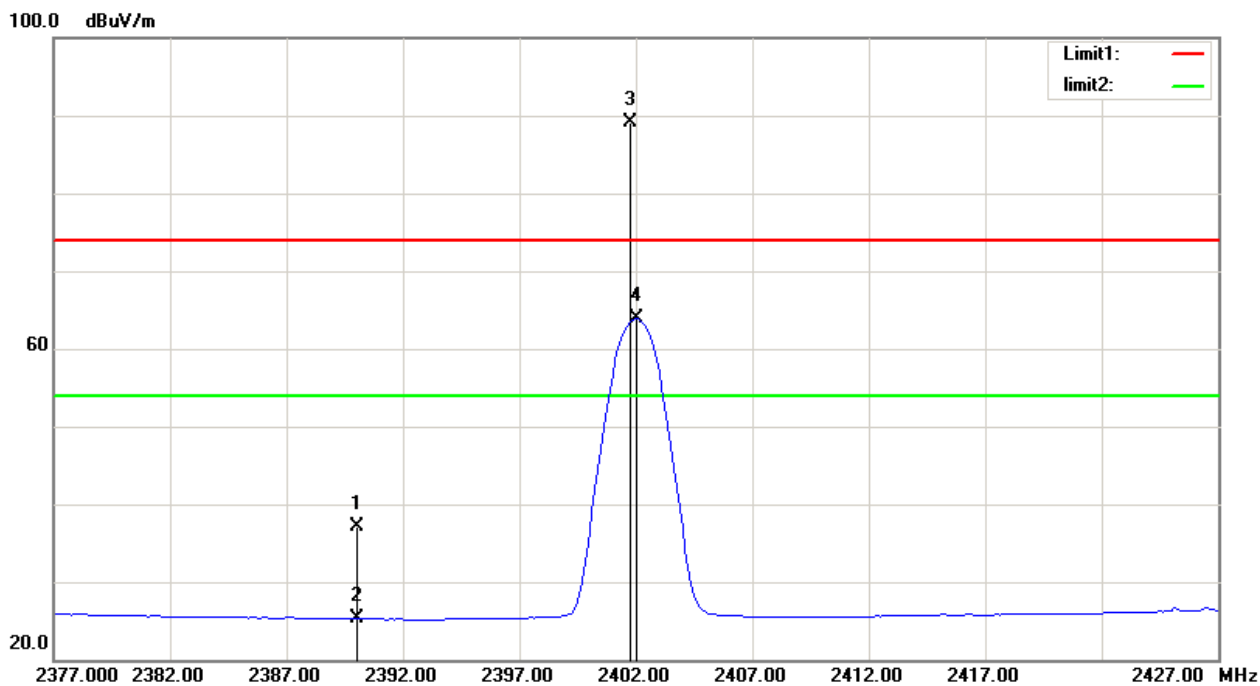

No.	Mk.	Freq.	Reading Level	Correct Factor	Measurement	Limit	Over	Antenna Height	Table Degree	
		MHz	dBuV	dB	dBuV/m	dB/m	dB	cm	degree	Comment
1		2390.000	49.10	-12.02	37.08	74.00	-36.92	peak	150	345
2		2390.000	37.26	-12.02	25.24	54.00	-28.76	AVG	150	345
3	*	2401.750	101.04	-11.99	89.05	74.00	15.05	peak	150	345 NO LIMIT
4	X	2402.000	75.81	-11.98	63.83	54.00	9.83	AVG	150	345 NO LIMIT

*:Maximum data x:Over limit !:over margin

<Reference Only

Test Mode: TX 2480 MHz_CH39_1Mbps

Vertical

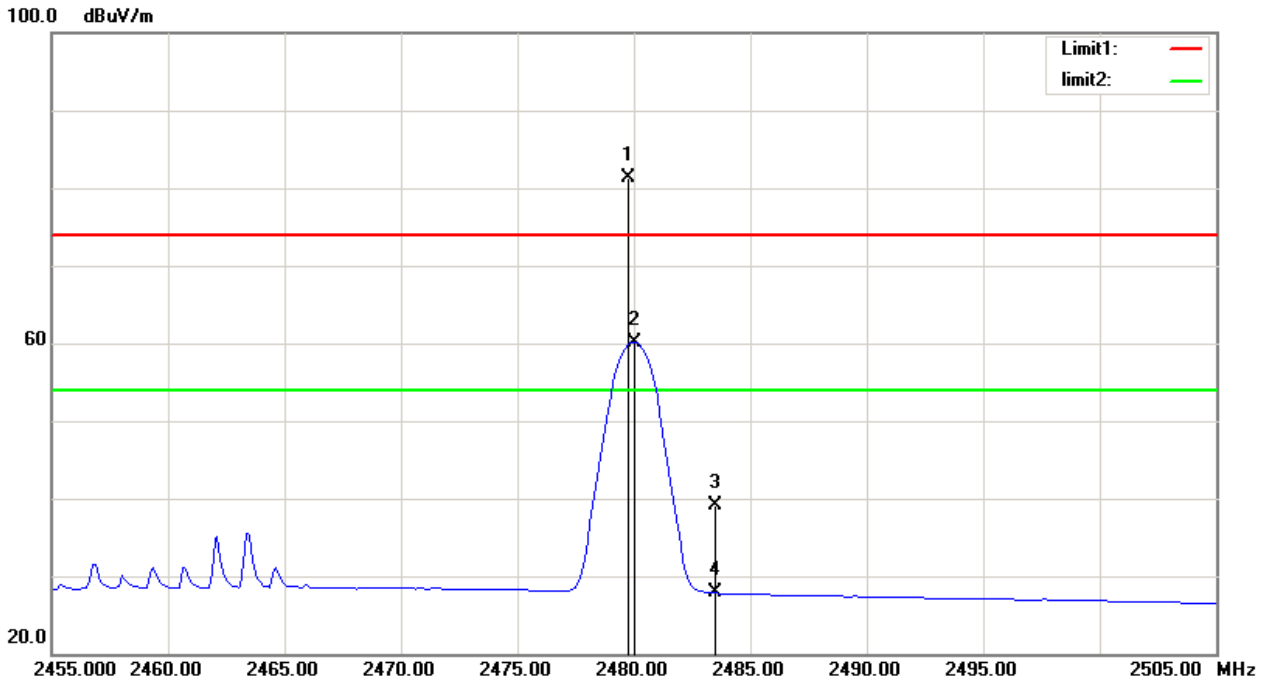

No.	Mk.	Freq. MHz	Reading Level dBuV	Correct Factor dB	Measure- ment dBuV/m	Limit dB/m	Over dB	Detector	Antenna Height cm	Table Degree	Comment
1	*	2479.750	93.12	-11.74	81.38	74.00	7.38	peak	150	304	NO LIMIT
2	X	2480.000	71.85	-11.74	60.11	54.00	6.11	AVG	150	304	NO LIMIT
3		2483.500	50.80	-11.72	39.08	74.00	-34.92	peak	150	304	
4		2483.500	39.54	-11.72	27.82	54.00	-26.18	AVG	150	304	

*:Maximum data x:Over limit !:over margin

<Reference Only

Test Mode: TX 2480 MHz_CH39_1Mbps

Horizontal

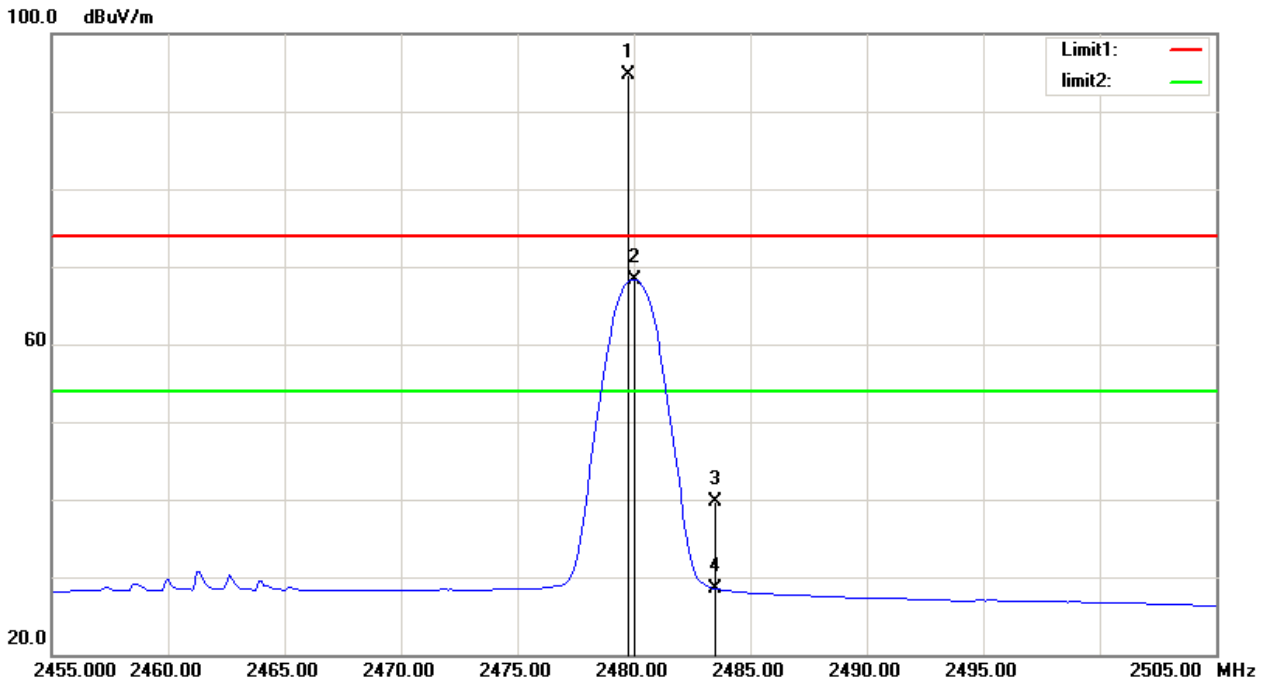

No.	Mk.	Freq.	Reading Level	Correct Factor	Measurement	Limit	Over	Antenna Height	Table Degree		
		MHz	dBuV	dB	dBuV/m	dB/m	dB	cm	degree	Comment	
1	*	2479.750	106.35	-11.74	94.61	74.00	20.61	peak	150	353	NO LIMIT
2	X	2480.000	80.12	-11.74	68.38	54.00	14.38	AVG	150	353	NO LIMIT
3		2483.500	51.51	-11.72	39.79	74.00	-34.21	peak	150	353	
4		2483.500	40.18	-11.72	28.46	54.00	-25.54	AVG	150	353	

*:Maximum data x:Over limit !:over margin

<Reference Only

Test Mode: TX 2402 MHz_CH00_2Mbps

Vertical

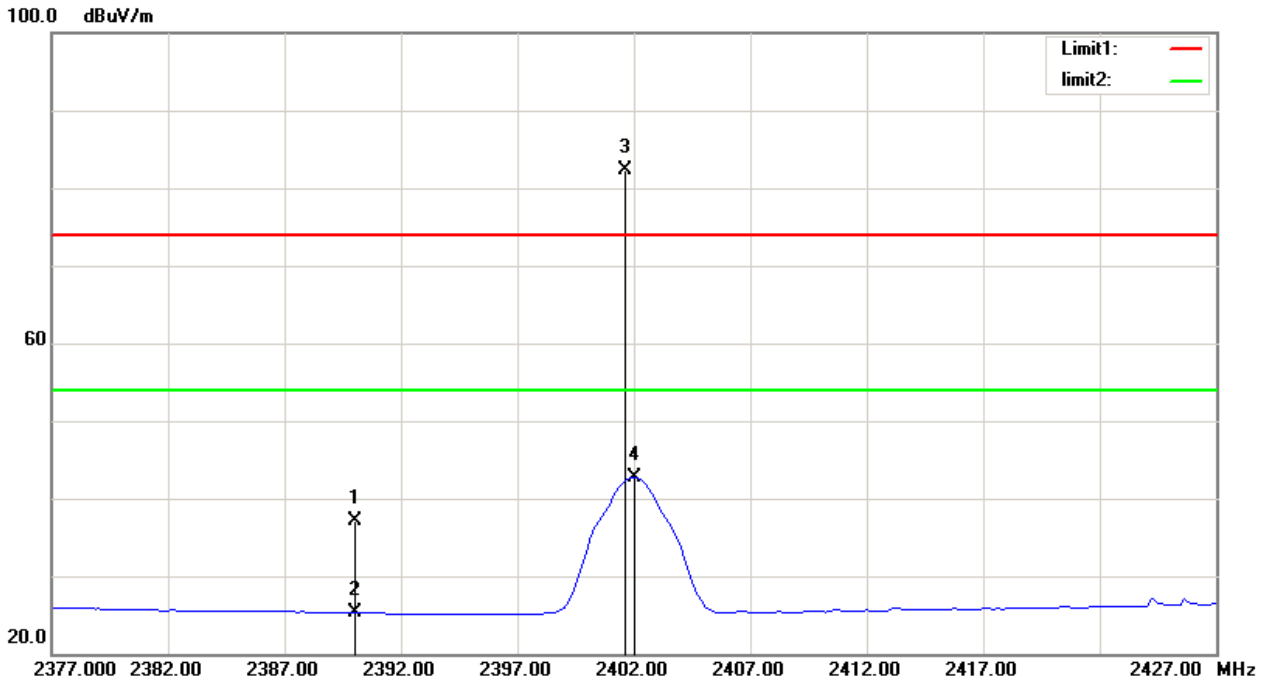

No.	Mk.	Freq.	Reading Level	Correct Factor	Measurement	Limit	Over	Antenna Height	Table Degree	
		MHz	dBuV	dB	dBuV/m	dB/m	dB	cm	degree	Comment
1		2390.000	49.09	-12.02	37.07	74.00	-36.93	150	303	
2		2390.000	37.26	-12.02	25.24	54.00	-28.76	150	303	
3	*	2401.625	94.30	-11.99	82.31	74.00	8.31	150	303	NO LIMIT
4		2402.000	54.69	-11.98	42.71	54.00	-11.29	150	303	NO LIMIT

*:Maximum data x:Over limit !:over margin

<Reference Only

Test Mode: TX 2402 MHz_CH00_2Mbps

Horizontal

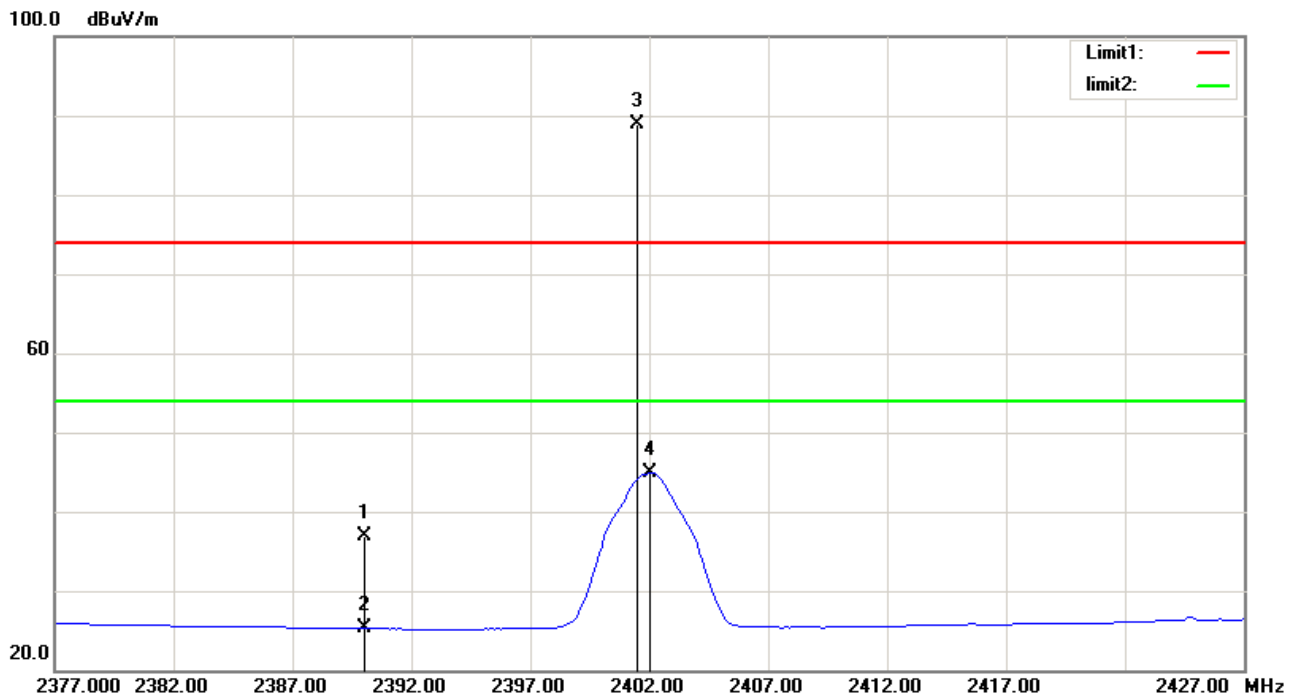

No.	Mk.	Freq. MHz	Reading Level dBuV	Correct Factor dB	Measure- ment dBuV/m	Limit dB/m	Over dB	Detector	Antenna Height cm	Table Degree	Comment
1		2390.000	48.90	-12.02	36.88	74.00	-37.12	peak	150	353	
2		2390.000	37.27	-12.02	25.25	54.00	-28.75	AVG	150	353	
3	*	2401.500	100.83	-11.99	88.84	74.00	14.84	peak	150	353	NO LIMIT
4		2402.000	56.83	-11.98	44.85	54.00	-9.15	AVG	150	353	NO LIMIT

*:Maximum data x:Over limit !:over margin

⟨ Reference Only

Test Mode: TX 2480 MHz_CH39_2Mbps

Vertical

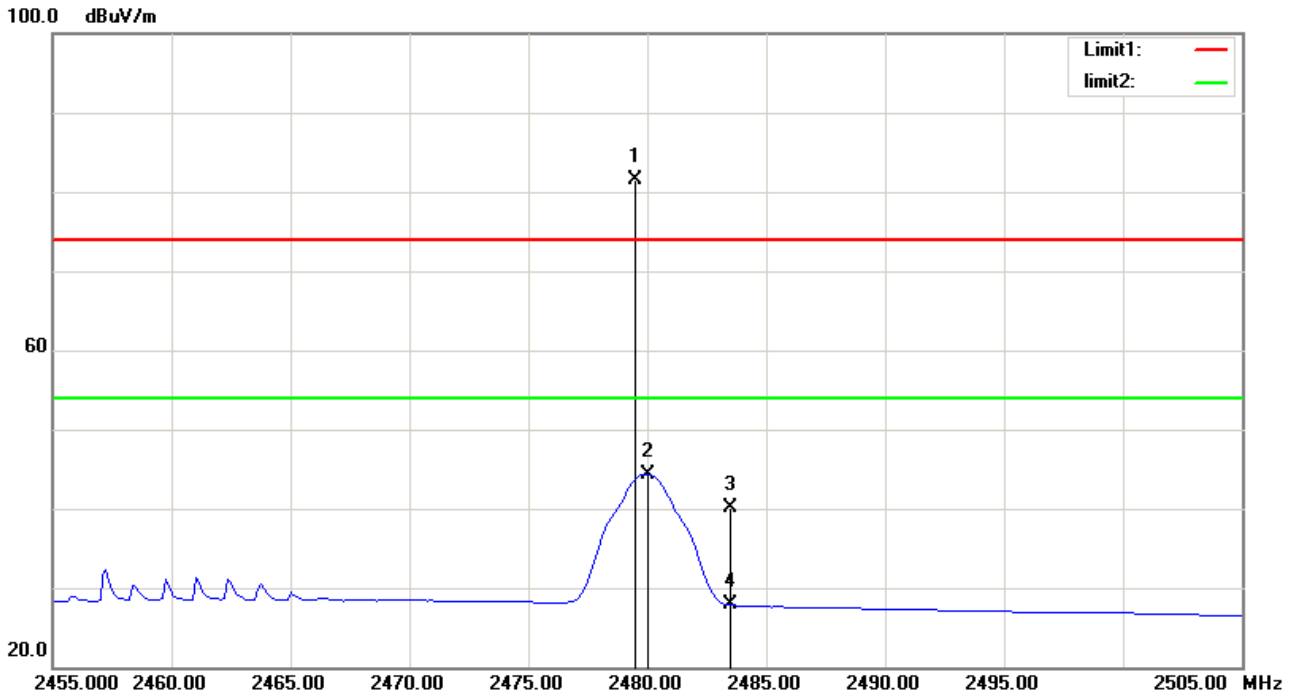

No.	Mk.	Freq. MHz	Reading Level dBuV	Correct Factor dB	Measure- ment dBuV/m	Limit dB/m	Over dB	Detector	Antenna Height cm	Table Degree	Comment
1	*	2479.500	93.16	-11.74	81.42	74.00	7.42	peak	150	303	NO LIMIT
2		2480.000	56.09	-11.74	44.35	54.00	-9.65	AVG	150	303	NO LIMIT
3		2483.500	51.78	-11.72	40.06	74.00	-33.94	peak	150	303	
4		2483.500	39.55	-11.72	27.83	54.00	-26.17	AVG	150	303	

*:Maximum data x:Over limit !:over margin

(Reference Only)

Test Mode: TX 2480 MHz_CH39_2Mbps

Horizontal

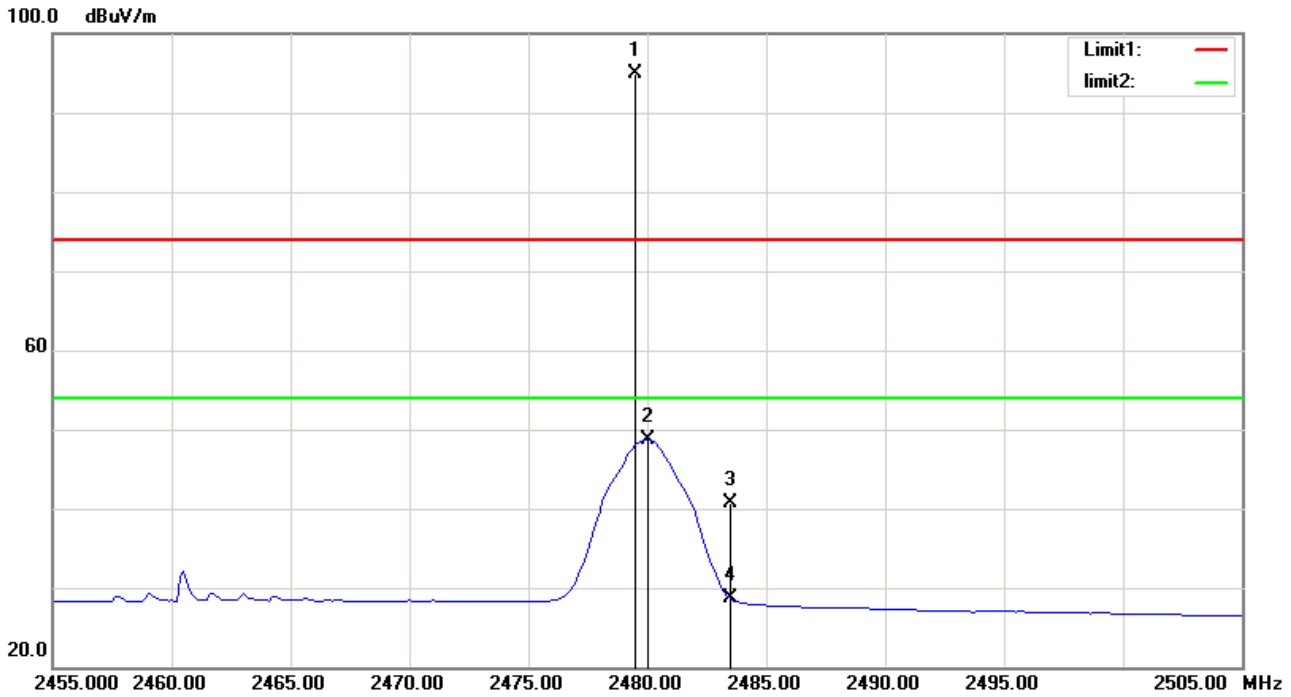

No.	Mk.	Freq.	Reading Level	Correct Factor	Measurement	Limit	Over	Antenna Height	Table Degree		
		MHz	dBuV	dB	dBuV/m	dB/m	dB	cm	degree	Comment	
1	*	2479.500	106.61	-11.74	94.87	74.00	20.87	peak	150	354	NO LIMIT
2		2480.000	60.45	-11.74	48.71	54.00	-5.29	AVG	150	354	NO LIMIT
3		2483.500	52.44	-11.72	40.72	74.00	-33.28	peak	150	354	
4		2483.500	40.33	-11.72	28.61	54.00	-25.39	AVG	150	354	

*:Maximum data x:Over limit !:over margin

⟨Reference Only

5.9 TEST RESULTS - ABOVE 1000MHz(HARMONIC)

Test Mode: TX 2402 MHz_CH00_1Mbps

Vertical

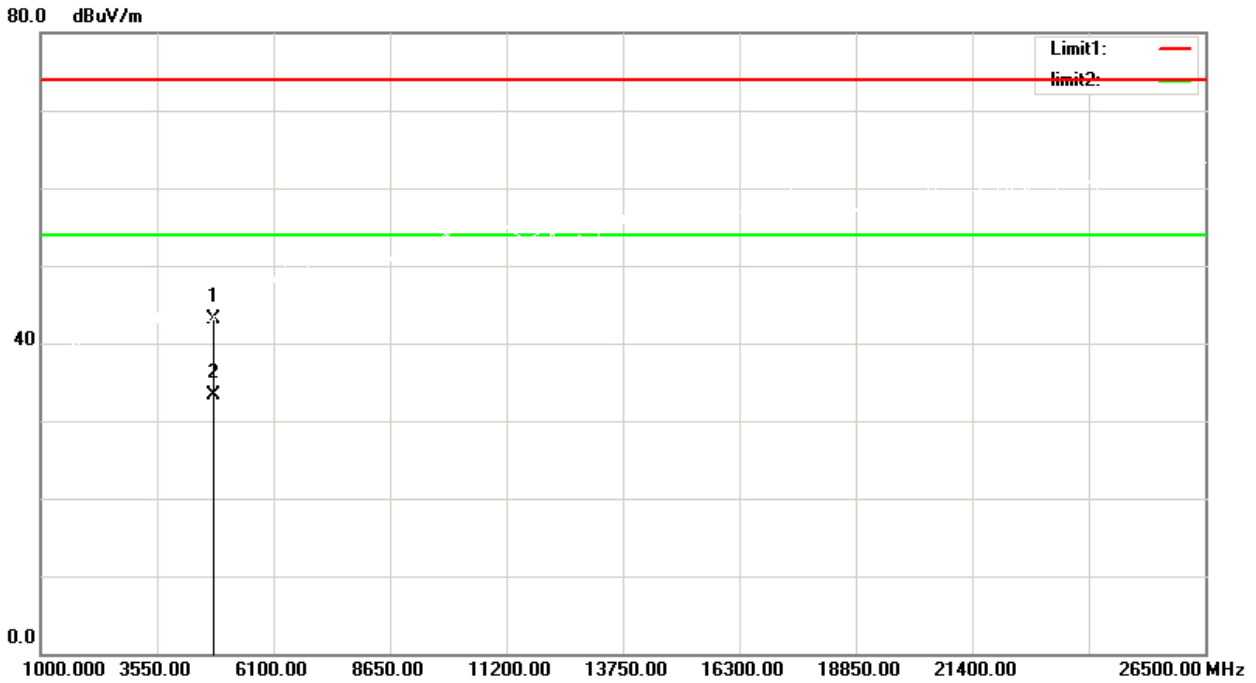

No. Mk.	Freq. MHz	Reading Level dBuV	Correct Factor dB	Measure- ment dBuV/m	Limit dB/m	Over dB	Detector	Antenna Height cm	Table Degree degree	Comment
1	4804.000	50.59	-7.53	43.06	74.00	-30.94	peak	150	85	
2 *	4804.000	40.76	-7.53	33.23	54.00	-20.77	AVG	150	85	

*:Maximum data x:Over limit !:over margin

⟨Reference Only

Test Mode: TX 2402 MHz_CH00_1Mbps

Horizontal

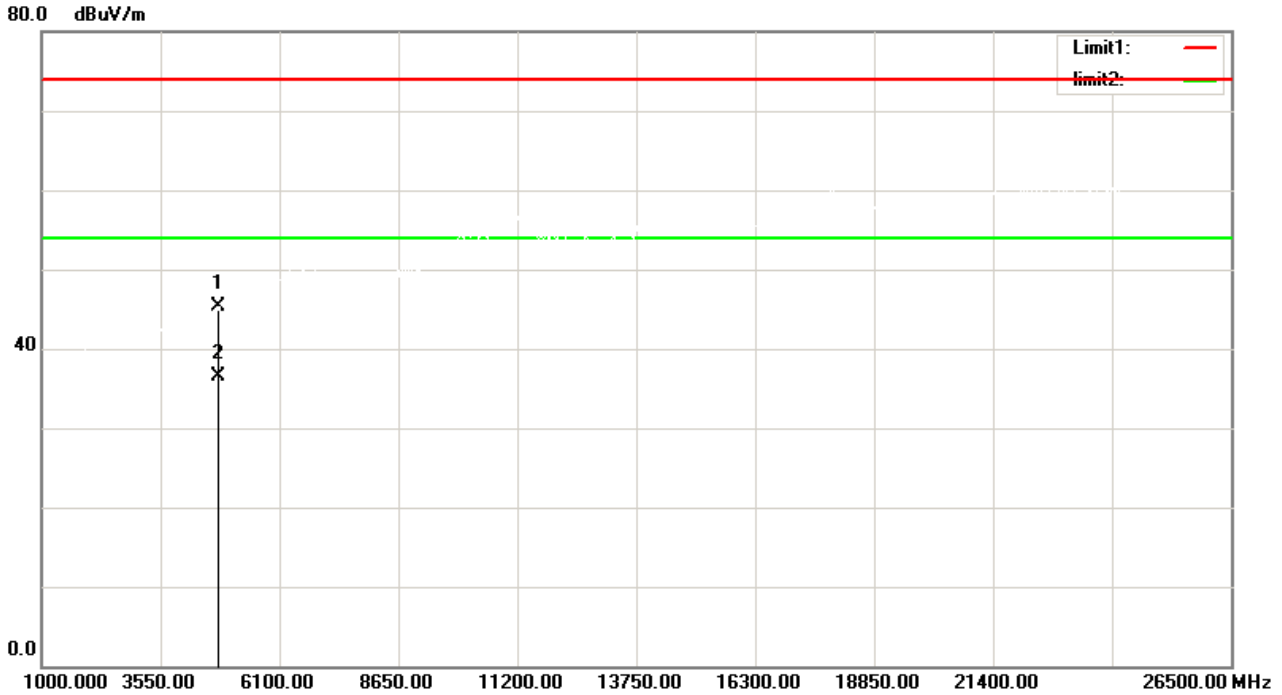

No.	Mk.	Freq.	Reading Level	Correct Factor	Measurement	Limit	Over	Antenna Height	Table Degree	Comment
		MHz	dBuV	dB	dBuV/m	dB/m	dB	cm	degree	
1		4804.000	52.76	-7.53	45.23	74.00	-28.77	peak	150	245
2	*	4804.000	44.02	-7.53	36.49	54.00	-17.51	AVG	150	245

*:Maximum data x:Over limit |:over margin

⟨Reference Only

Test Mode: TX 2440 MHz_CH19_1Mbps

Vertical

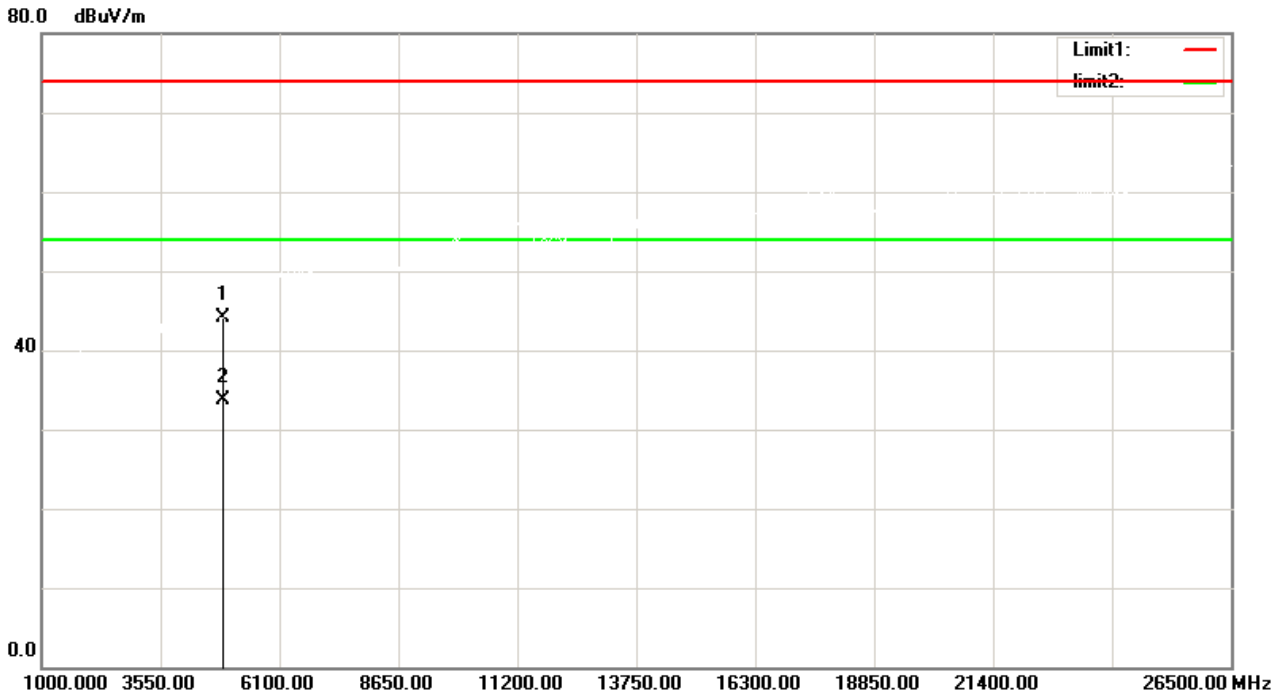

No.	Mk.	Freq.	Reading Level	Correct Factor	Measurement	Limit	Over	Antenna Height	Table Degree	
		MHz	dBuV	dB	dBuV/m	dB/m	dB	cm	degree	Comment
1		4880.000	51.34	-7.31	44.03	74.00	-29.97	peak	150	78
2	*	4880.000	40.95	-7.31	33.64	54.00	-20.36	AVG	150	78

*:Maximum data x:Over limit !:over margin

<Reference Only

Test Mode: TX 2440 MHz_CH19_1Mbps

Horizontal

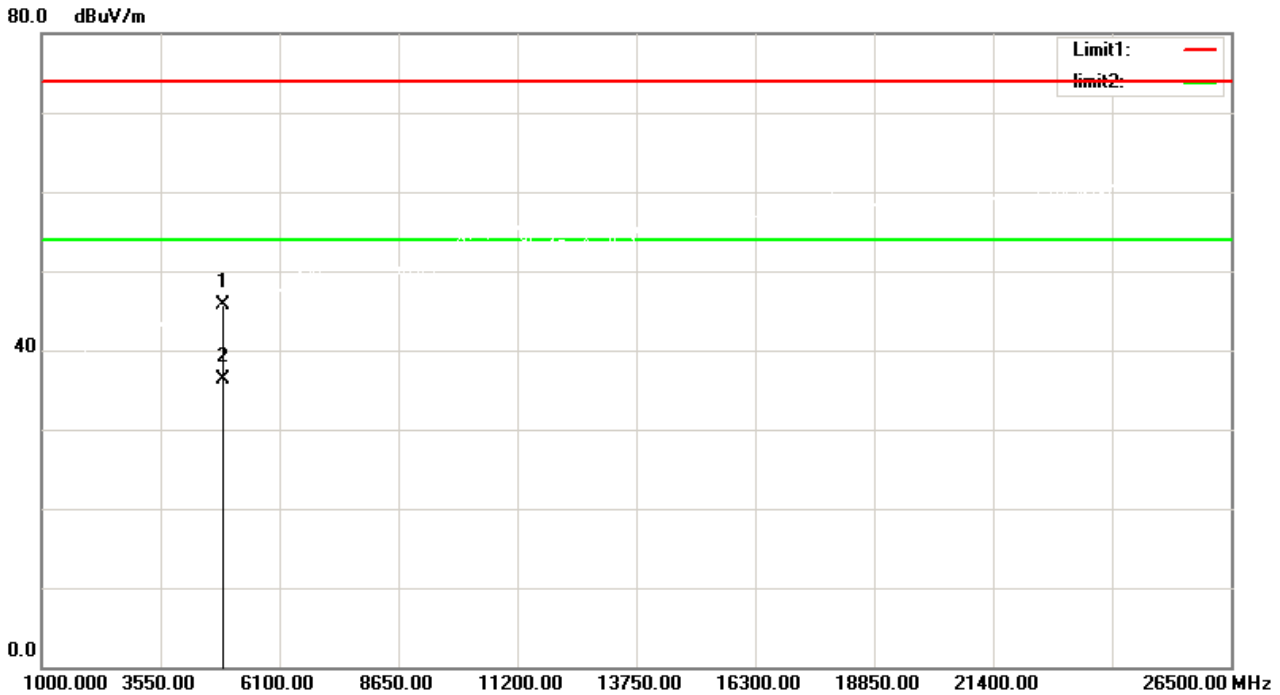

No.	Mk.	Freq. MHz	Reading Level dBuV	Correct Factor dB	Measure- ment dBuV/m	Limit dB/m	Over dB	Detector	Antenna Height cm	Table Degree	Comment
1		4880.000	52.93	-7.31	45.62	74.00	-28.38	peak	150	286	
2	*	4880.000	43.56	-7.31	36.25	54.00	-17.75	AVG	150	286	

*:Maximum data x:Over limit !:over margin

(Reference Only)

Test Mode: TX 2480 MHz_CH39_1Mbps

Vertical

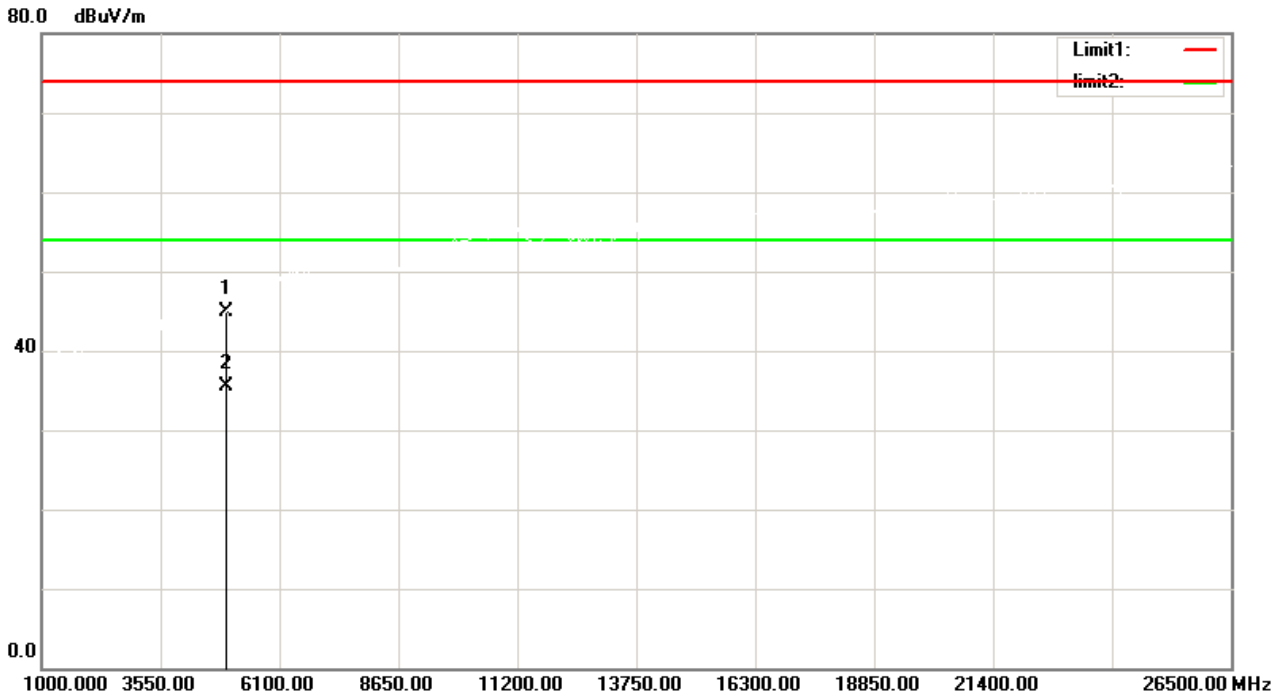

No.	Mk.	Freq. MHz	Reading Level dBuV	Correct Factor dB	Measure- ment dBuV/m	Limit dB/m	Over dB	Antenna Height cm	Table Degree	Comment
1		4960.000	51.90	-7.09	44.81	74.00	-29.19	peak	150	36
2	*	4960.000	42.50	-7.09	35.41	54.00	-18.59	AVG	150	36

*:Maximum data x:Over limit !:over margin

(Reference Only)

Test Mode: TX 2480 MHz_CH39_1Mbps

Horizontal

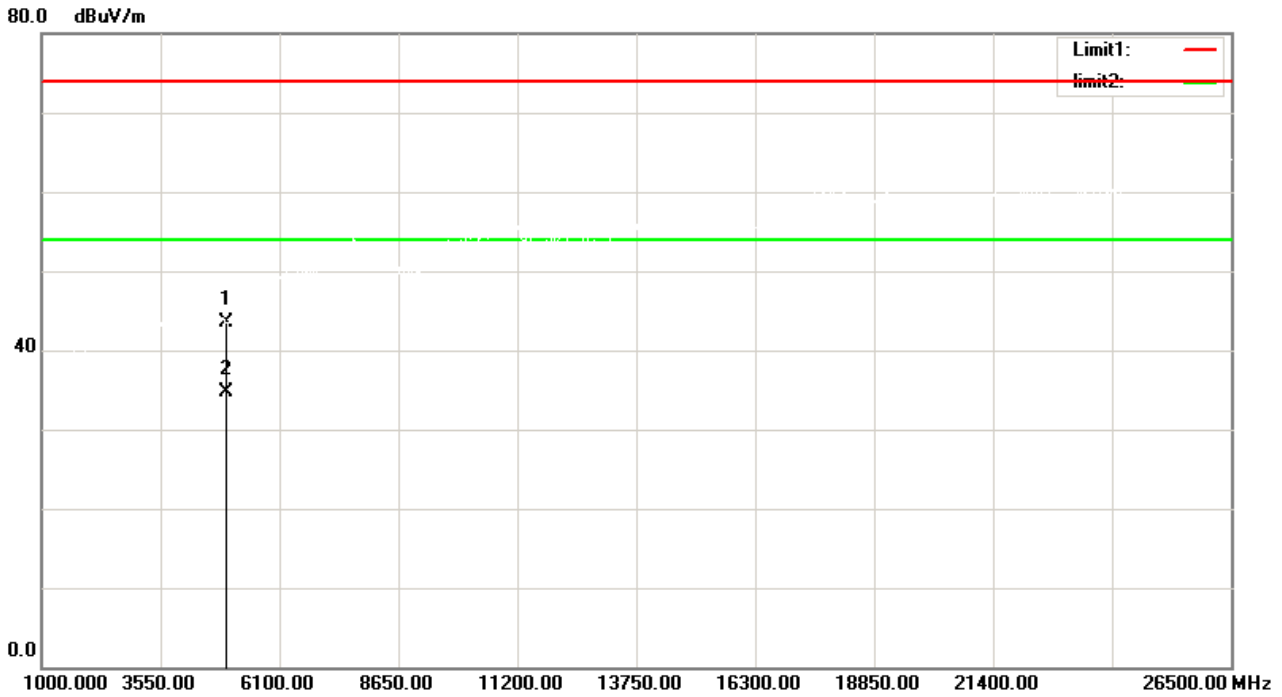

No.	Mk.	Freq. MHz	Reading Level dBuV	Correct Factor dB	Measure- ment dBuV/m	Limit dB/m	Over dB	Detector	Antenna Height cm	Table Degree	Comment
1		4960.000	50.60	-7.09	43.51	74.00	-30.49	peak	150	258	
2	*	4960.000	41.71	-7.09	34.62	54.00	-19.38	AVG	150	258	

*:Maximum data x:Over limit !:over margin

(Reference Only)

Test Mode: TX 2402 MHz_CH00_2Mbps

Vertical

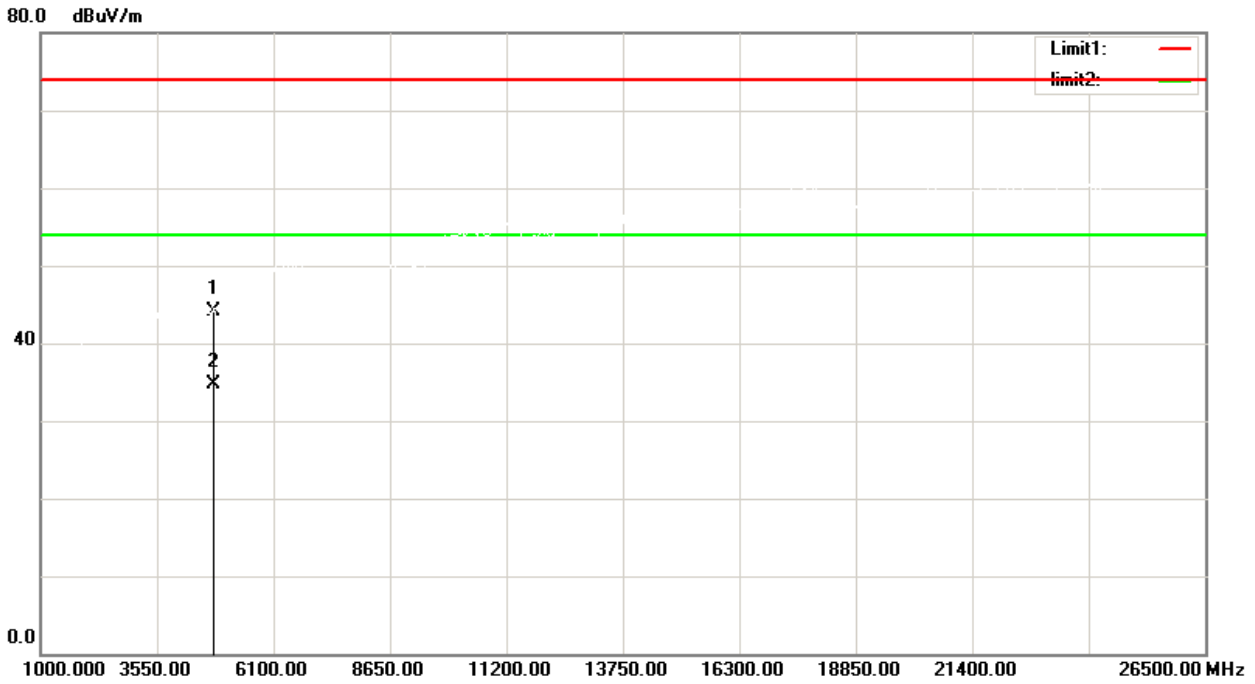

No.	Mk.	Freq. MHz	Reading Level dBuV	Correct Factor dB	Measure- ment dBuV/m	Limit dB/m	Over dB	Detector	Antenna Height cm	Table Degree degree	Comment
1		4804.000	51.59	-7.53	44.06	74.00	-29.94	peak	150	54	
2	*	4804.000	42.18	-7.53	34.65	54.00	-19.35	AVG	150	54	

*:Maximum data x:Over limit !:over margin

< Reference Only

Test Mode: TX 2402 MHz_CH00_2Mbps

Horizontal

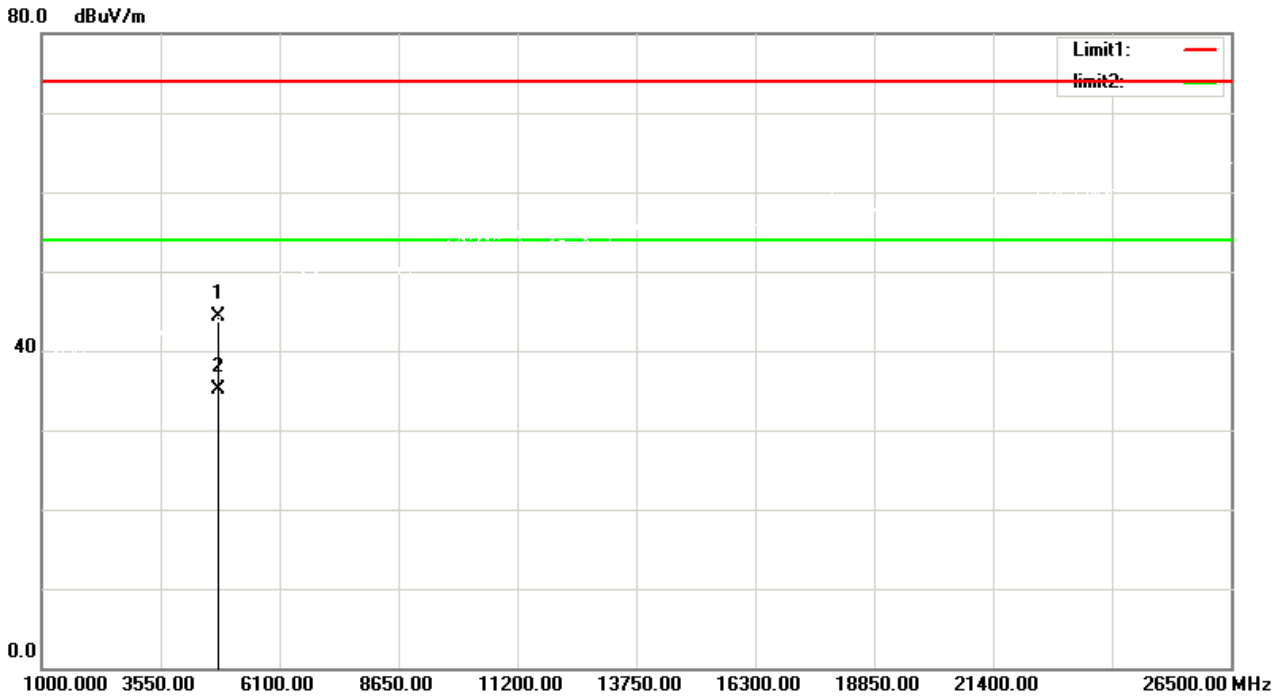

No.	Mk.	Freq. MHz	Reading Level dBuV	Correct Factor dB	Measure- ment dBuV/m	Limit dB/m	Over dB	Detector	Antenna Height cm	Table Degree	Comment
1		4804.000	51.76	-7.53	44.23	74.00	-29.77	peak	150	278	
2	*	4804.000	42.65	-7.53	35.12	54.00	-18.88	AVG	150	278	

*:Maximum data x:Over limit !:over margin

<Reference Only

Test Mode: TX 2440 MHz_CH19_2Mbps

Vertical

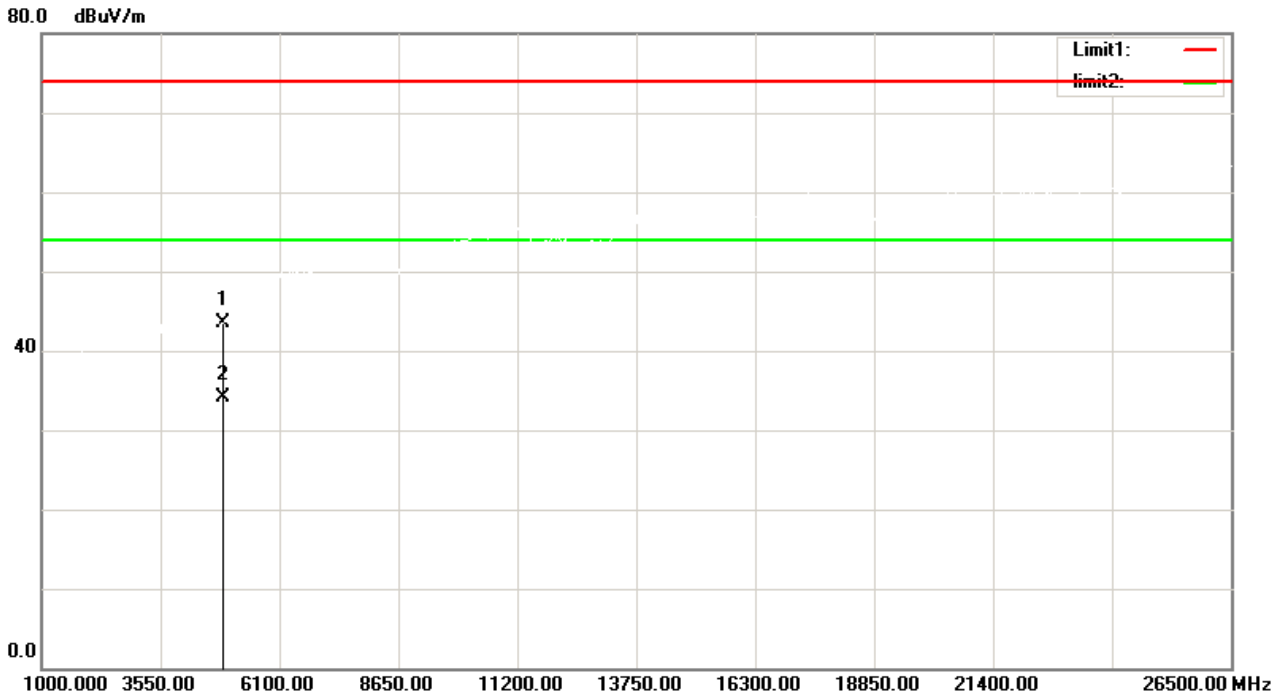

No.	Mk.	Freq. MHz	Reading Level dBuV	Correct Factor dB	Measure- ment dBuV/m	Limit dB/m	Over dB	Detector	Antenna Height cm	Table Degree	Comment
1		4880.000	50.84	-7.31	43.53	74.00	-30.47	peak	150	69	
2	*	4880.000	41.42	-7.31	34.11	54.00	-19.89	AVG	150	69	

*:Maximum data x:Over limit !:over margin

⟨ Reference Only

Test Mode: TX 2440 MHz_CH19_2Mbps

Horizontal

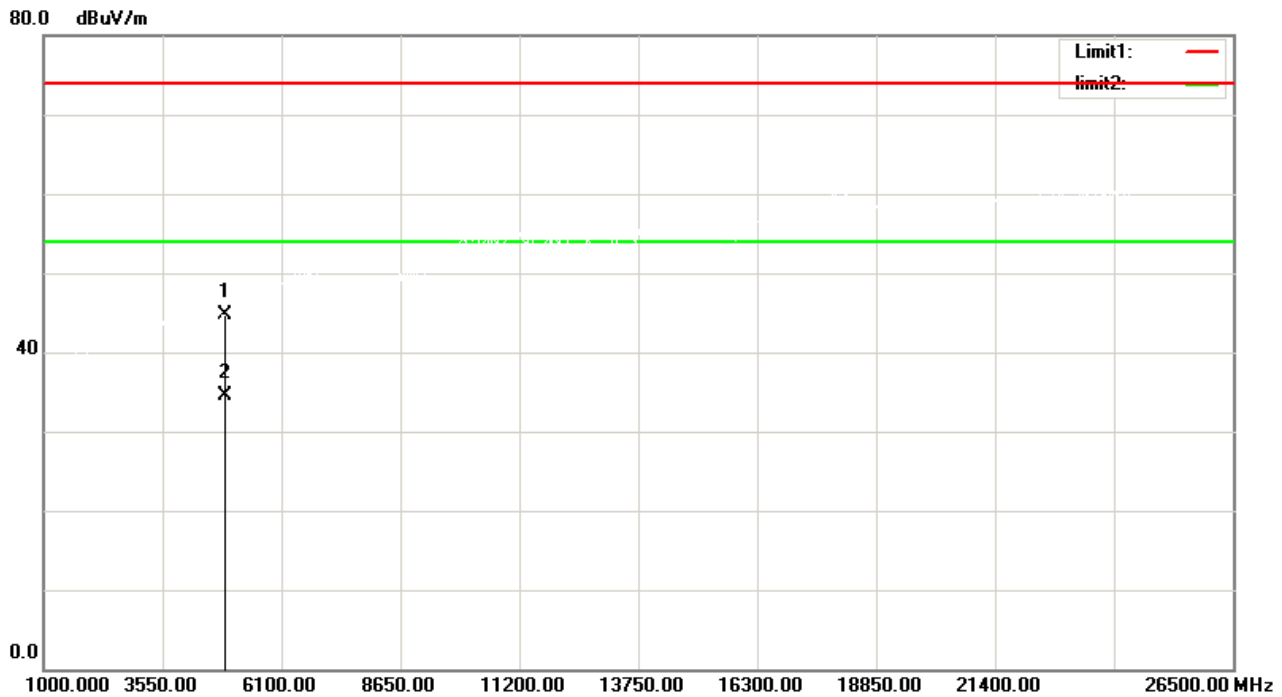

No.	Mk.	Freq. MHz	Reading Level dBuV	Correct Factor dB	Measure- ment dBuV/m	Limit dB/m	Over dB	Detector	Antenna Height cm	Table Degree	Comment
1		4880.000	51.93	-7.31	44.62	74.00	-29.38	peak	150	294	
2	*	4880.000	41.72	-7.31	34.41	54.00	-19.59	AVG	150	294	

*:Maximum data x:Over limit !:over margin

(Reference Only)

Test Mode: TX 2480 MHz_CH39_2Mbps

Vertical

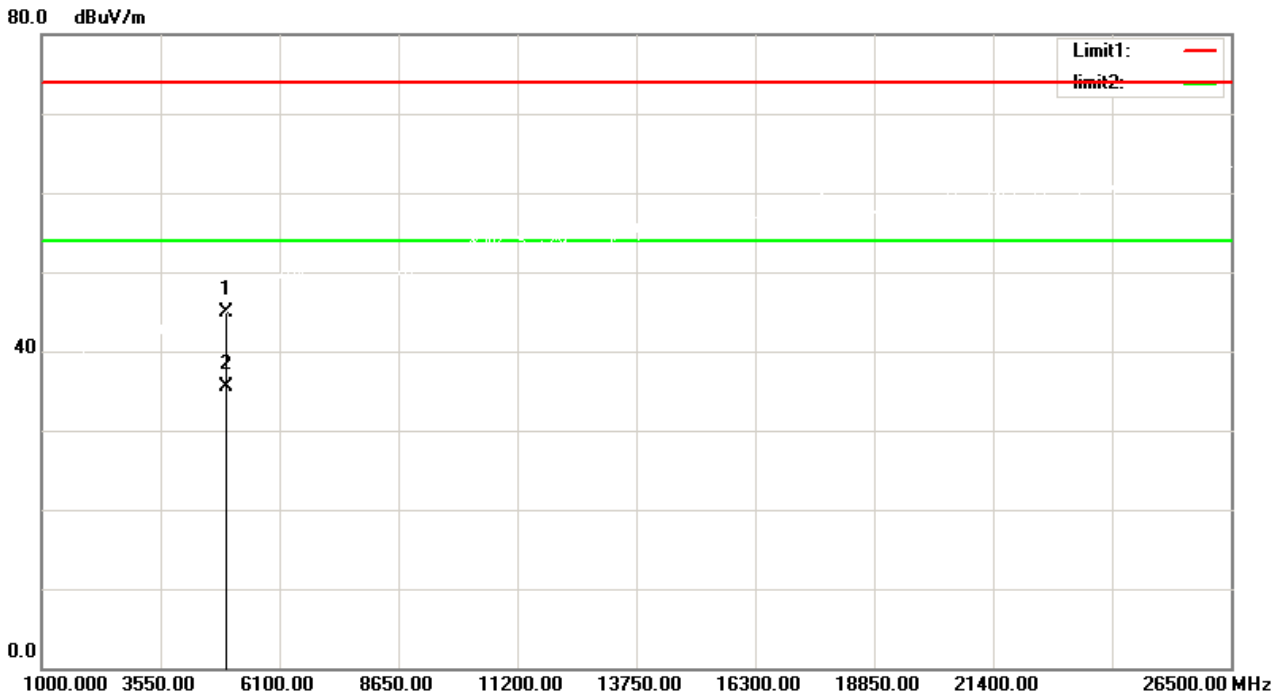

No.	Mk.	Freq. MHz	Reading Level dBuV	Correct Factor dB	Measure- ment dBuV/m	Limit dB/m	Over dB	Detector	Antenna Height cm	Table Degree	Comment
1		4960.000	51.90	-7.09	44.81	74.00	-29.19	peak	150	79	
2	*	4960.000	42.55	-7.09	35.46	54.00	-18.54	AVG	150	79	

*:Maximum data x:Over limit !:over margin

(Reference Only)

Test Mode: TX 2480 MHz_CH39_2Mbps

Horizontal

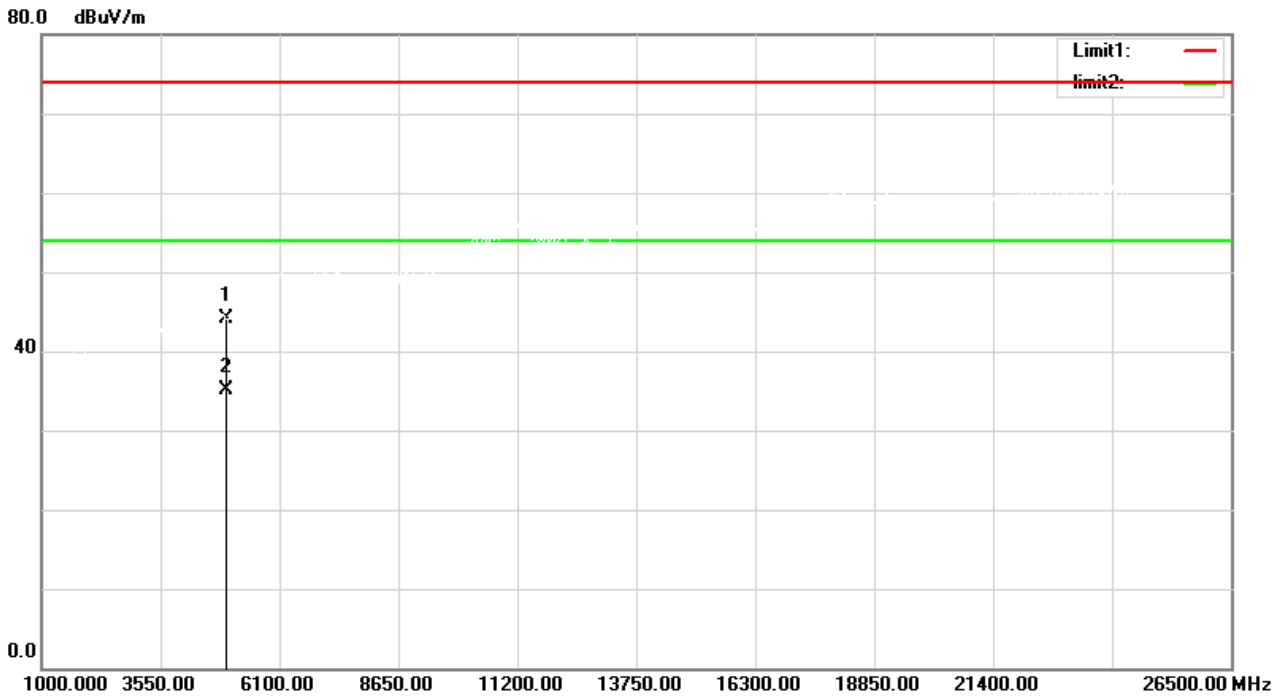

No.	Mk.	Freq. MHz	Reading Level dBuV	Correct Factor dB	Measure- ment dBuV/m	Limit dB/m	Over dB	Detector	Antenna Height cm	Table Degree	Comment
1		4960.000	51.10	-7.09	44.01	74.00	-29.99	peak	150	249	
2	*	4960.000	42.25	-7.09	35.16	54.00	-18.84	AVG	150	249	

*:Maximum data x:Over limit !:over margin

(Reference Only)

6 BANDWIDTH TEST

6.1 LIMIT

FCC Part15, Subpart C (15.247)& RSS-Gen/ RSS-247		
Section	Test Item	Limit
15.247(a)(2) RSS-Gen6.7 RSS-247 5.2 (a)	Bandwidth	≥ 500 kHz (6dB bandwidth)

6.2 TEST PROCEDURE AND SETTING

- a. The EUT was directly connected to the spectrum analyzer and antenna output port as show in the block diagram below.
- b. Spectrum Setting:
 For 6dB Bandwidth RBW= 100 kHz, VBW=300 kHz, Sweep time =Auto.
 For 99% Bandwidth RBW=30kHz, VBW=100kHz, Sweep time =Auto for 1Mbps.
 RBW=100kHz, VBW=300kHz, Sweep time =Auto for 2Mbps.

6.3 MEASUREMENT INSTRUMENTS LIST

Item	Kind of Equipment	Manufacturer	Type No.	Serial No.	Calibrated until
1	Spectrum analyzer	KEYSIGHT	N9010A	MY55150427	2023/05/26
2	Attenuator	Mini-Circuits	BW-S10W2	101109	N/A
3	RF Cable	Mi-cable	C10-01-01-1	100309	N/A

6.4 TEST SETUP



6.5 EUT OPERATION CONDITIONS

The EUT tested system was configured as the statements of 4.5 unless otherwise a special operating condition is specified in the follows during the testing.

6.6 TESTRESULTS

TX Mode_1Mbps				
Channel	Frequency (MHz)	6 dB bandwidth (MHz)	99%OBW (MHz)	Result
CH00	2402	0.6985	1.0557	PASS
CH19	2440	0.6850	1.0584	PASS
CH39	2480	0.7005	1.0562	PASS

6dB

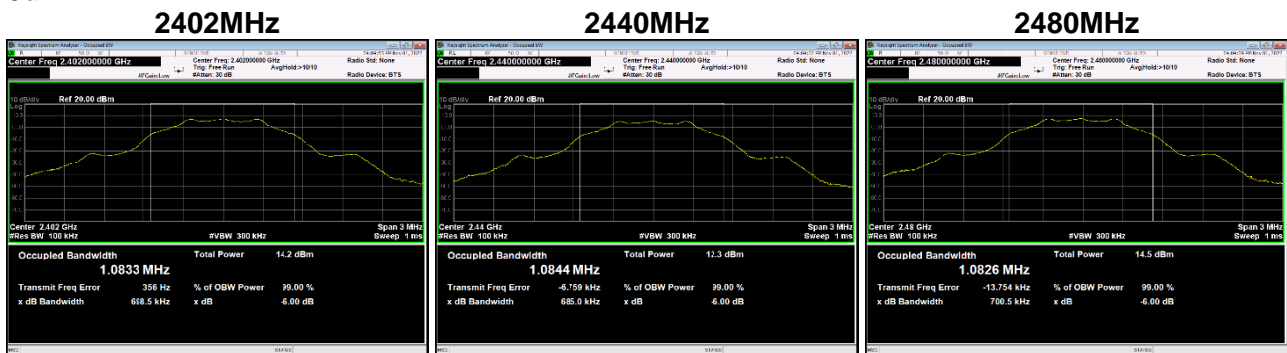

99%

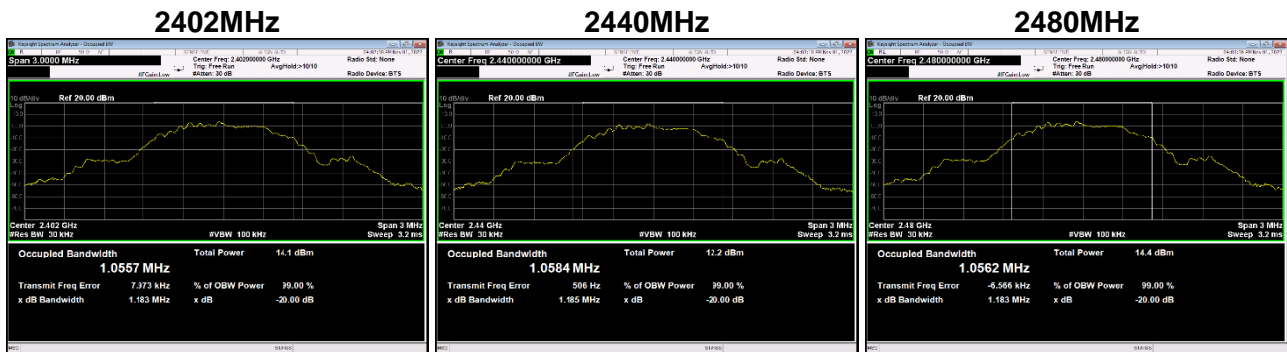

TX Mode_2Mbps				
Channel	Frequency (MHz)	6 dB bandwidth (MHz)	99%OBW (MHz)	Result
CH00	2402	1.270	2.0555	PASS
CH19	2440	1.273	2.0514	PASS
CH39	2480	1.266	2.0535	PASS

6dB

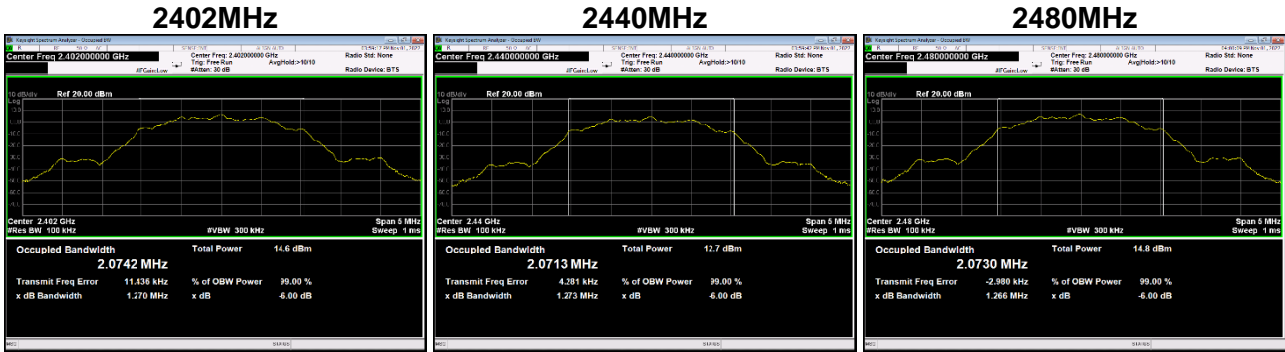

99%

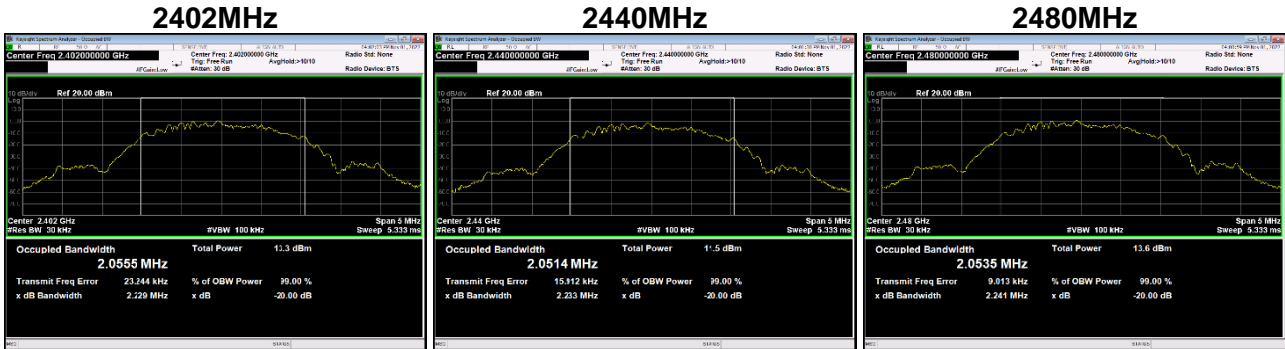

7 MAXIMUM OUTPUT POWER

7.1 LIMIT

FCC Part15, Subpart C (15.247)&RSS-247		
Section	Test Item	Limit
15.247(b)(3) RSS-2475.4 (d)	Maximum Output Power	1 watt or 30dBm

7.2 TEST PROCEDURE

- a. The EUT was directly connected to the spectrum analyzer and antenna output port as show in the block diagram below.
- b. The maximum conducted output power was performed in accordance with method 11.9.1.3(for peak power)ofANSI C63.10-2013.

7.3 MEASUREMENT INSTRUMENTS LIST

Item	Kind of Equipment	Manufacturer	Type No.	Serial No.	Calibrated until
1	Spectrum analyzer	KEYSIGHT	N9010A	MY55150427	2023/05/26
2	Attenuator	Mini-Circuits	BW-S10W2	101109	N/A
3	RF Cable	Mi-cable	C10-01-01-1	100309	N/A

7.4 TEST SETUP

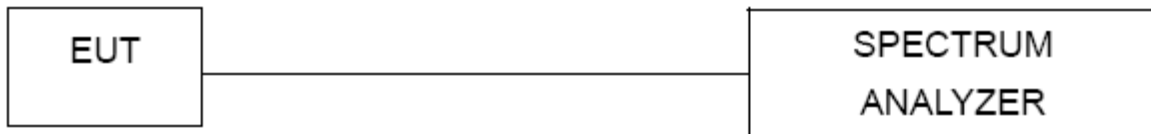

7.5 EUT OPERATION CONDITIONS

The EUT tested system was configured as the statements of 4.5 unless otherwise a special operating condition is specified in the follows during the testing.

7.6 TESTRESULTS

TX Mode_1Mbps				
Channel	Frequency (MHz)	Output Power (dBm)	Output Power (W)	Result
CH00	2402	8.241	0.00667	PASS
CH19	2440	6.548	0.00452	PASS
CH39	2480	8.553	0.00717	PASS
Limit	30dBm / 1W			

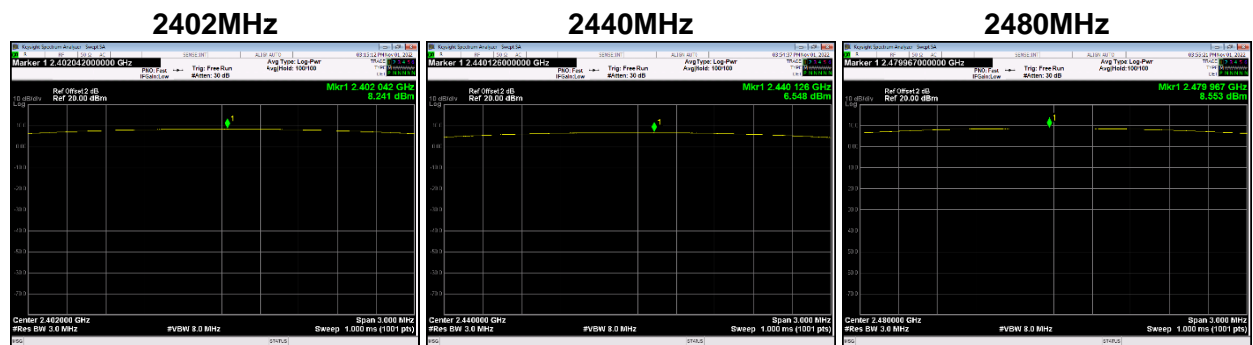

TX Mode_2Mbps				
Channel	Frequency (MHz)	Output Power (dBm)	Output Power (W)	Result
CH00	2402	8.339	0.00682	PASS
CH19	2440	6.655	0.00463	PASS
CH39	2480	8.586	0.00722	PASS
Limit	30dBm / 1W			

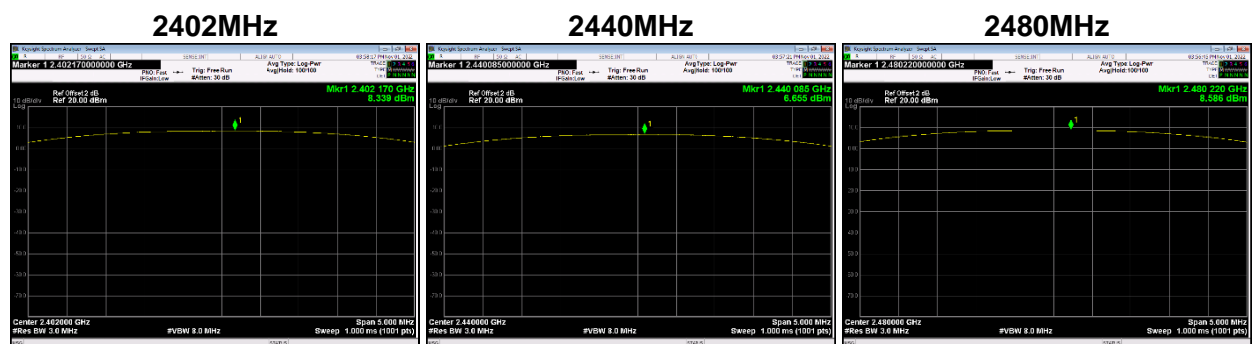

8 CONDUCTED SPURIOUS EMISSION

8.1 LIMIT

For FCC

In any 100 kHz bandwidth outside the frequency band in which the spread spectrum or digitally modulated intentional radiator is operating, the radio frequency power that is produced by the intentional radiator shall be at least 20 dB below that in the 100 kHz bandwidth within the band that contains the highest level of the desired power, based on either an RF conducted or a radiated measurement, provided the transmitter demonstrates compliance with the peak Output Power limits. If the transmitter complies with the Output Power limits based on the use of RMS averaging over a time interval, as permitted under paragraph (b)(3) of this section, the attenuation required under this paragraph shall be 30 dB instead of 20 dB. Attenuation below the general limits specified in Section 15.209(a) is not required.

For ISED

In any 100 kHz bandwidth outside the frequency band in which the spread spectrum or digitally modulated device is operating, the RF power that is produced shall be at least 20 dB below that in the 100 kHz bandwidth within the band that contains the highest level of the desired power, based on either an RF conducted or a radiated measurement, provided that the transmitter demonstrates compliance with the peak Output Power limits. If the transmitter complies with the Output Power limits based on the use of root-mean-square averaging over a time interval, as permitted under section 5.4(d), the attenuation required shall be 30 dB instead of 20 dB. Attenuation below the general field strength limits specified in RSS-Gen is not required.

8.2 TEST PROCEDURE

- a. The EUT was directly connected to the spectrum analyzer and antenna output port as show in the block diagram below.
- b. Spectrum Setting : RBW= 100 kHz, VBW=300 kHz, Sweep time = Auto.

8.3 MEASUREMENT INSTRUMENTS LIST

Item	Kind of Equipment	Manufacturer	Type No.	Serial No.	Calibrated until
1	Spectrum analyzer	KEYSIGHT	N9010A	MY55150427	2023/05/26
2	Attenuator	Mini-Circuits	BW-S10W2	101109	N/A
3	RF Cable	Mi-cable	C10-01-01-1	100309	N/A

8.4 TEST SETUP



8.5 EUT OPERATION CONDITIONS

The EUT tested system was configured as the statements of 4.5 unless otherwise a special operating condition is specified in the follows during the testing.

8.6 TEST RESULTS

TX Mode_1Mbps

Bandedge- CH00 (Lower)

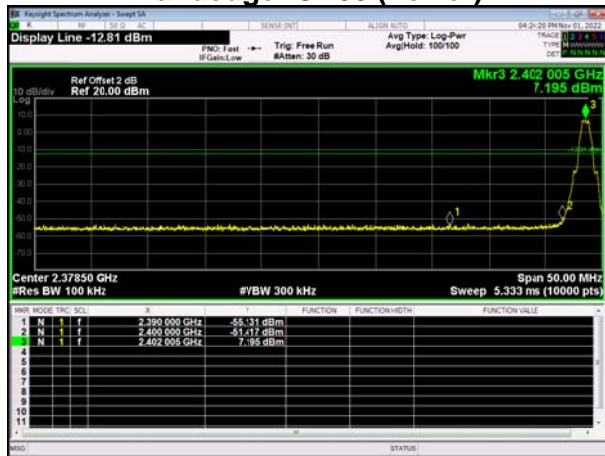

Bandedge CH39 (Upper)

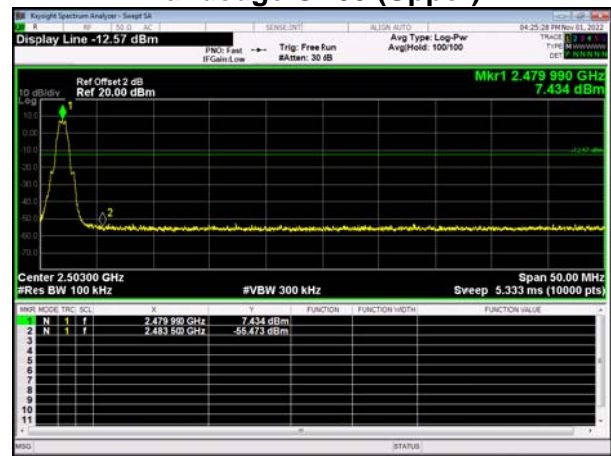

CH00 – 10th Harmonic of the fundamental frequency

2402MHz



2440MHz

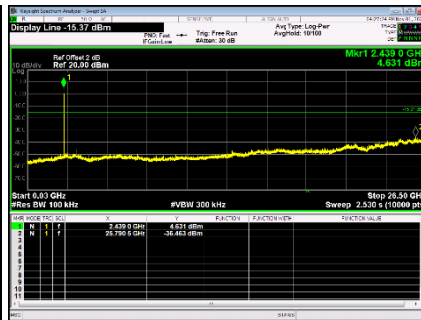

2480MHz

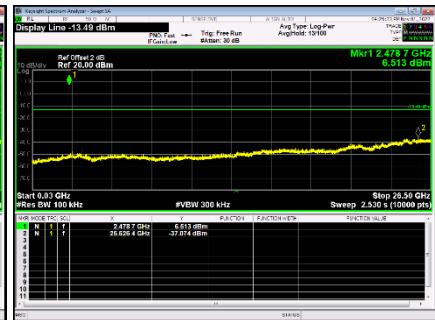

TX Mode_2Mbps

Bandedge- CH00 (Lower)

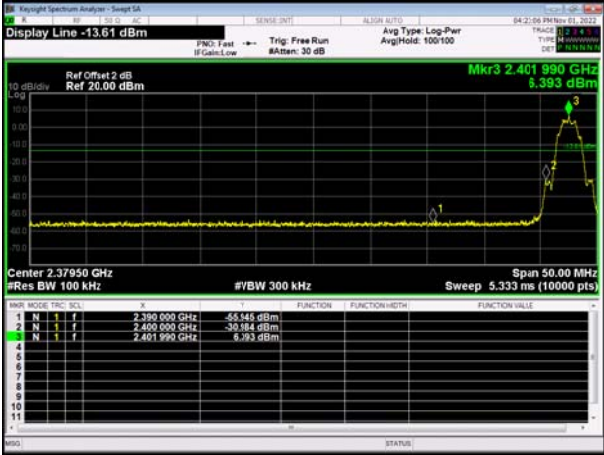

Bandedge CH39 (Upper)

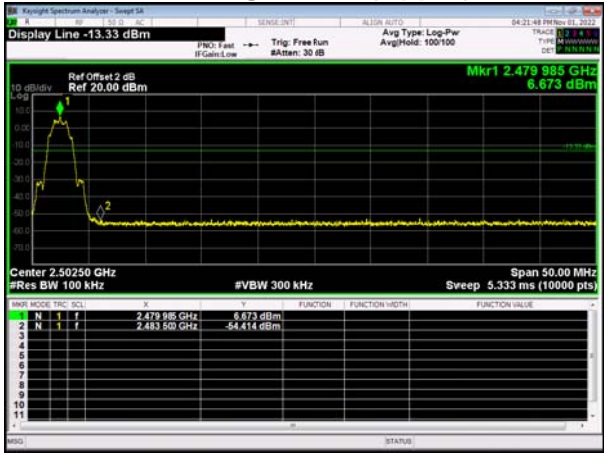

CH00 – 10th Harmonic of the fundamental frequency

2402MHz

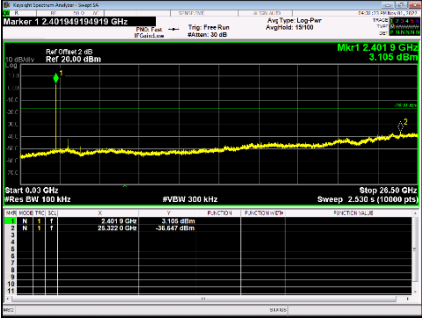

2440MHz

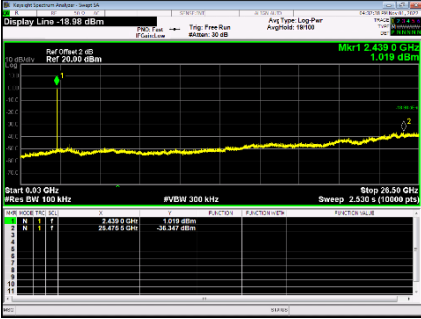

2480MHz

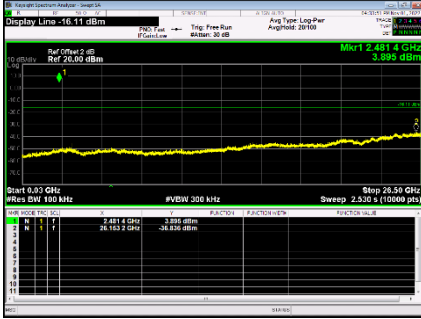

9 POWER SPECTRAL DENSITY TEST

9.1 LIMIT

FCC Part15, Subpart C (15.247)&RSS-247		
Section	Test Item	Limit
15.247(e) RSS-2475.2 (b)	Power Spectral Density	8 dBm (in any 3 kHz)

9.2 TEST PROCEDURE

- a. The EUT was directly connected to the spectrum analyzer and antenna output port as show in the block diagram below.
- b. Spectrum Setting: RBW=3 kHz, VBW=10kHz, Sweep time = auto.

9.3 MEASUREMENT INSTRUMENTS LIST

Item	Kind of Equipment	Manufacturer	Type No.	Serial No.	Calibrated until
1	Spectrum analyzer	KEYSIGHT	N9010A	MY55150427	2023/05/26
2	Attenuator	Mini-Circuits	BW-S10W2	101109	N/A
3	RF Cable	Mi-cable	C10-01-01-1	100309	N/A

9.4 TEST SETUP

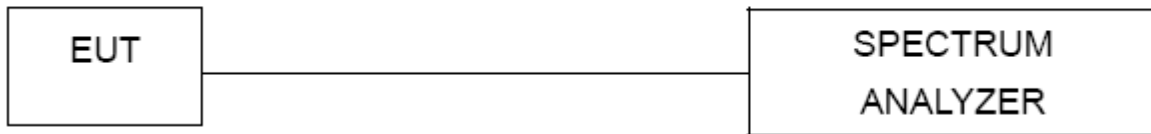

9.5 EUT OPERATION CONDITIONS

The EUT tested system was configured as the statements of 3.5 unless otherwise a special operating condition is specified in the follows during the testing.

9.6 TEST RESULTS

TX Mode_1Mbps				
Channel	Frequency (MHz)	Power SpectralDensity (dBm/3 kHz)	Limit: <dBm/3KHz	Result
CH00	2402	-7.594	8	PASS
CH19	2440	-9.377	8	PASS
CH39	2480	-7.298	8	PASS

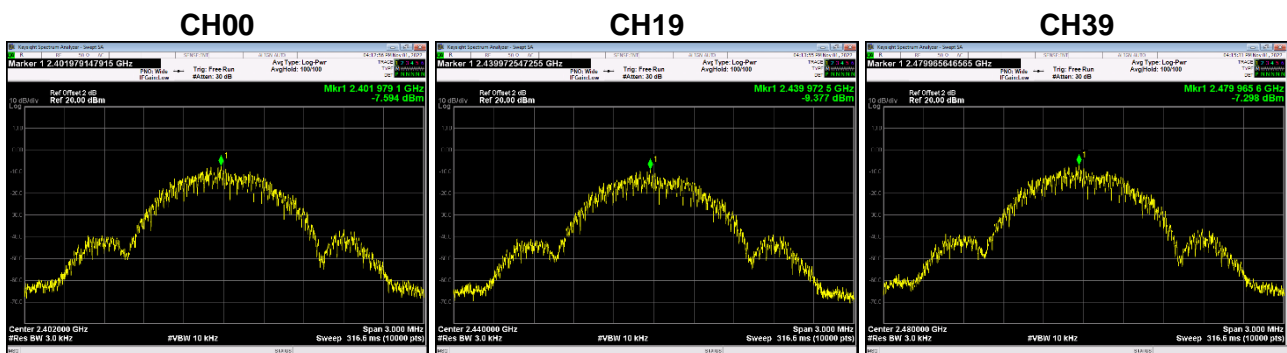

TX Mode_2Mbps				
Channel	Frequency (MHz)	Power SpectralDensity (dBm/3 kHz)	Limit: <dBm/3KHz	Result
CH00	2402	-9.919	8	PASS
CH19	2440	-11.811	8	PASS
CH39	2480	-9.666	8	PASS

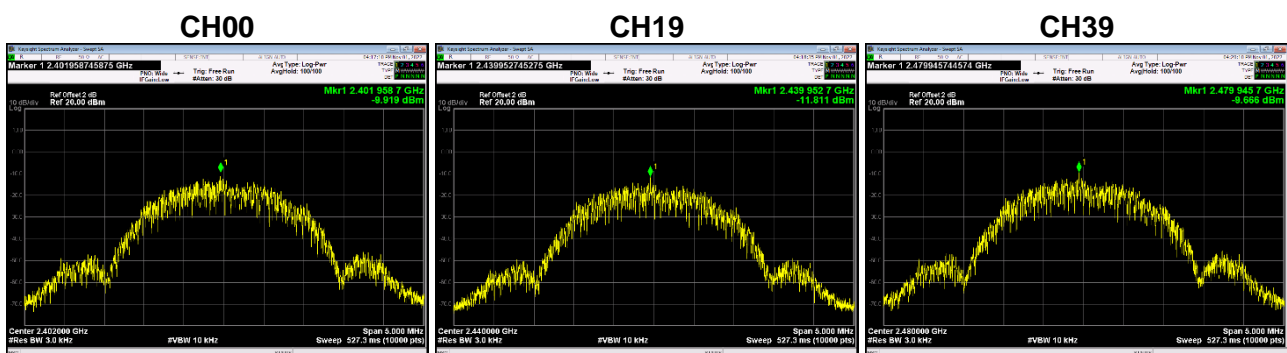

10 FREQUENCY STABILITY MEASUREMENT

10.1 LIMIT

RSS-Gen			
Section	Test Item	Limit	Frequency Range (MHz)
RSS-Gen 6.11	Frequency Stability	Specified in the user's manual	2402-2480

10.2 TEST PROCEDURE

- a. The EUT was directly connected to the spectrum analyzer and antenna output port as show in the block diagram below.
- b. Spectrum Setting:

Spectrum Parameter	Setting
Attenuation	Auto
Span Frequency	Entire absence of modulationemissionsbandwidth
RBW	10 kHz
VBW	10kHz
Sweep Time	Auto

10.3 MEASUREMENT INSTRUMENTS LIST

Item	Kind of Equipment	Manufacturer	Type No.	Serial No.	Calibrated until
1	Spectrum analyzer	KEYSIGHT	N9010A	MY55150427	2023/05/26
2	Attenuator	Mini-Circuits	BW-S10W2	101109	N/A
3	RF Cable	Mi-cable	C10-01-01-1	100309	N/A
4	Temperature conditioning	Guan Jian.HTH1000	-20-130°C	GJ1000-10D001	N/A
5	DC Power Supply	G.KE	IPR-10010D	010931954	N/A

10.4 TEST SETUP

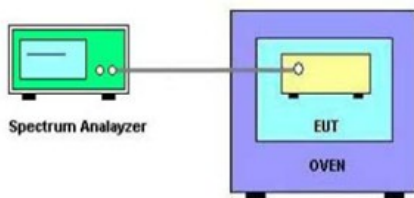

10.5 EUT OPERATION CONDITIONS

The EUT was programmed to be in continuously transmitting mode.

10.6 TEST RESULTS

	Temperature vs. Frequency Stability	
Voltage	Temperature	Measurement Frequency (MHz)
120V	(°C)	2402
	0	2402.0014
	25	2402.0011
	40	2402.0016
89V	25	2402.0012
Max. Deviation (MHz)		0.0016
Max. Deviation (ppm)		0.67

Note:89V is the end point voltage, and products below 3.5V will cease working.

END OF TEST REPORT