



FCC TEST REPORT (15.407)

REPORT NO.: RF121112C19-4
MODEL NO.: JT-B1APAAAAM
FCC ID: ACJ-JT-B1APAAZAMA
RECEIVED: Oct. 17, 2012
TESTED: Nov. 15 ~ Dec. 26, 2012
ISSUED: Jan. 21, 2013

APPLICANT: Panasonic Corporation of North America

ADDRESS: One Panasonic way,4B-8,Secaucus,New Jersey,United states 07094

ISSUED BY: Bureau Veritas Consumer Products Services (H.K.) Ltd., Taoyuan Branch

LAB ADDRESS: No. 47, 14th Ling, Chia Pau Vil., Lin Kou Dist., New Taipei City, Taiwan, R.O.C.

TEST LOCATION: No. 19, Hwa Ya 2nd Rd, Wen Hwa Tsuen, Kwei Shan Hsiang, Taoyuan Hsien 333, Taiwan, R.O.C.

This report should not be used by the client to claim product certification, approval, or endorsement by TAF or any government agencies.



This report is for your exclusive use. Any copying or replication of this report to or for any other person or entity, or use of our name or trademark, is permitted only with our prior written permission. This report sets forth our findings solely with respect to the test samples identified herein. The results set forth in this report are not indicative or representative of the quality or characteristics of the lot from which a test sample was taken or any similar or identical product unless specifically and expressly noted. Our report includes all of the tests requested by you and the results thereof based upon the information that you provided to us. You have 60 days from date of issuance of this report to notify us of any material error or omission caused by our negligence, provided, however, that such notice shall be in writing and shall specifically address the issue you wish to raise. A failure to raise such issue within the prescribed time shall constitute your unqualified acceptance of the completeness of this report, the tests conducted and the correctness of the report contents. Unless specific mention, the uncertainty of measurement has been explicitly taken into account to declare the compliance or non-compliance to the specification.



TABLE OF CONTENTS

RELEASE CONTROL RECORD	4
1. CERTIFICATION.....	5
2. SUMMARY OF TEST RESULTS	6
2.1 MEASUREMENT UNCERTAINTY	6
3. GENERAL INFORMATION.....	7
3.1 GENERAL DESCRIPTION OF EUT	7
3.2 DESCRIPTION OF TEST MODES.....	8
3.2.1 TEST MODE APPLICABILITY AND TESTED CHANNEL DETAIL.....	9
3.3 DUTY CYCLE OF TEST SIGNAL.....	11
3.4 DESCRIPTION OF SUPPORT UNITS	12
3.4.1 CONFIGURATION OF SYSTEM UNDER TEST	12
3.5 GENERAL DESCRIPTION OF APPLIED STANDARDS	12
4. TEST TYPES AND RESULTS	14
4.1 RADIATED EMISSION AND BANDEDGE MEASUREMENT	14
4.1.1 LIMITS OF RADIATED EMISSION AND BANDEDGE MEASUREMENT.....	14
4.1.2 LIMITS OF UNWANTED EMISSION OUT OF THE RESTRICTED BANDS	14
4.1.3 TEST INSTRUMENTS.....	15
4.1.4 TEST PROCEDURES	17
4.1.5 DEVIATION FROM TEST STANDARD	17
4.1.6 TEST SETUP.....	18
4.1.7 EUT OPERATING CONDITION	18
4.1.8 TEST RESULTS	19
4.2 CONDUCTED EMISSION MEASUREMENT	39
4.2.1 LIMITS OF CONDUCTED EMISSION MEASUREMENT	39
4.2.2 TEST INSTRUMENTS.....	39
4.2.3 TEST PROCEDURES	40
4.2.4 DEVIATION FROM TEST STANDARD	40
4.2.5 TEST SETUP.....	40
4.2.6 EUT OPERATING CONDITIONS	40
4.2.7 TEST RESULTS	41
4.3 PEAK TRANSMIT POWER MEASUREMENT	45
4.3.1 LIMITS OF PEAK TRANSMIT POWER MEASUREMENT	45
4.3.2 TEST SETUP.....	45
4.3.3 TEST INSTRUMENTS.....	46
4.3.4 TEST PROCEDURE.....	46
4.3.5 DEVIATION FROM TEST STANDARD	46
4.3.6 EUT OPERATING CONDITIONS	46
4.3.7 TEST RESULTS	47
4.4 PEAK POWER SPECTRAL DENSITY MEASUREMENT	49
4.4.1 LIMITS OF PEAK POWER SPECTRAL DENSITY MEASUREMENT	49
4.4.2 TEST SETUP.....	49
4.4.3 TEST INSTRUMENTS.....	49
4.4.4 TEST PROCEDURES	49
4.4.5 DEVIATION FROM TEST STANDARD	49
4.4.6 EUT OPERATING CONDITIONS	49
4.4.7 TEST RESULTS	50
4.5 PEAK POWER EXCURSION MEASUREMENT	51



4.5.1	LIMITS OF PEAK POWER EXCURSION MEASUREMENT	51
4.5.2	TEST SETUP	51
4.5.3	TEST INSTRUMENTS.....	51
4.5.4	TEST PROCEDURE.....	51
4.5.5	DEVIATION FROM TEST STANDARD	51
4.5.6	EUT OPERATING CONDITIONS	51
4.5.7	TEST RESULTS	52
4.6	FREQUENCY STABILITY	54
4.6.1	LIMITS OF FREQUENCY STABILITY MEASUREMENT.....	54
4.6.2	TEST SETUP.....	54
4.6.3	TEST INSTRUMENTS.....	54
4.6.4	TEST PROCEDURE.....	55
4.6.5	DEVIATION FROM TEST STANDARD	55
4.6.6	EUT OPERATING CONDITION	55
4.6.7	TEST RESULTS	56
5.	PHOTOGRAPHS OF THE TEST CONFIGURATION	57
6.	INFORMATION ON THE TESTING LABORATORIES.....	58
7.	APPENDIX A - MODIFICATIONS RECORDERS FOR ENGINEERING CHANGES TO THE EUT BY THE LAB	59



A D T

RELEASE CONTROL RECORD

ISSUE NO.	REASON FOR CHANGE	DATE ISSUED
RF121112C19-4	Original release	Jan. 21, 2013

1. CERTIFICATION

PRODUCT: Tablet Computer

MODEL: JT-B1APAAAAM

BRAND: Panasonic

APPLICANT: Panasonic Corporation of North America

TESTED: Nov. 15 ~ Dec. 26, 2012

TEST SAMPLE: ENGINEERING SAMPLE

STANDARDS: FCC Part 15, Subpart E (Section 15.407)

ANSI C63.10-2009

The above equipment (model: JT-B1APAAAAM) has been tested by **Bureau Veritas Consumer Products Services (H.K.) Ltd., Taoyuan Branch**, and found compliance with the requirement of the above standards. The test record, data evaluation & Equipment Under Test (EUT) configurations represented herein are true and accurate accounts of the measurements of the sample's EMC characteristics under the conditions specified in this report.

PREPARED BY :

Pettie Chen / Senior Specialist

, DATE : Jan. 21, 2013

APPROVED BY :

Ken Liu / Manager

, DATE : Jan. 21, 2013

2. SUMMARY OF TEST RESULTS

The EUT has been tested according to the following specifications:

APPLIED STANDARD: FCC PART 15, SUBPART E (SECTION 15.407)			
STANDARD SECTION	TEST TYPE	RESULT	REMARK
15.407(b)(6)	AC Power Conducted Emission	PASS	Meet the requirement of limit. Minimum passing margin is -15.04dB at 0.19717MHz.
15.407(b/1/2/3) (b)(6)	Spurious Emissions	PASS	Meet the requirement of limit. Minimum passing margin is -6.3dB at 10640.00MHz.
15.407(a/1/2)	Max Average Transmit Power	PASS	Meet the requirement of limit.
15.407(a)(6)	Peak Power Excursion	PASS	Meet the requirement of limit.
15.407(a/1/2)	Peak Power Spectral Density	PASS	Meet the requirement of limit.
15.407(g)	Frequency Stability	PASS	Meet the requirement of limit.
15.203	Antenna Requirement	PASS	No antenna connector is used.

2.1 MEASUREMENT UNCERTAINTY

Where relevant, the following measurement uncertainty levels have been estimated for tests performed on the EUT as specified in CISPR 16-4-2:

MEASUREMENT	FREQUENCY	UNCERTAINTY
Conducted emissions	9kHz~30MHz	2.44 dB
Radiated emissions	30MHz ~ 200MHz	2.93 dB
	200MHz ~1000MHz	2.95 dB
	1GHz ~ 18GHz	2.26 dB
	18GHz ~ 40GHz	1.94 dB

This uncertainty represents an expanded uncertainty expressed at approximately the 95% confidence level using a coverage factor of $k = 2$.

3. GENERAL INFORMATION

3.1 GENERAL DESCRIPTION OF EUT

EUT	Tablet Computer
MODEL NO.	JT-B1APAAAAM
POWER SUPPLY	5.0Vdc (adapter or host equipment) 3.7Vdc (Li-ion battery)
MODULATION TYPE	64QAM, 16QAM, QPSK, BPSK
MODULATION TECHNOLOGY	OFDM
TRANSFER RATE	802.11a: 54.0/ 48.0/ 36.0/ 24.0/ 18.0/ 12.0/ 9.0/ 6.0Mbps 802.11n: up to 72.2Mbps
OPERATING FREQUENCY	5180 ~ 5240MHz, 5260 ~ 5320MHz & 5500 ~ 5700MHz
NUMBER OF CHANNEL	5180 ~ 5240MHz: 4 for 802.11a, 802.11n (20MHz) 5260 ~ 5320MHz: 4 for 802.11a, 802.11n (20MHz) 5500 ~ 5700MHz: 8 for 802.11a, 802.11n (20MHz)
OUTPUT POWER	13.335mW for 5180 ~ 5240MHz 12.445mW for 5260 ~ 5320MHz 14.060mW for 5500 ~ 5700MHz
ANTENNA TYPE	Monopole antenna with 1.6dBi gain (5180 ~ 5240MHz) Monopole antenna with 1.9dBi gain (5260 ~ 5320MHz) Monopole antenna with 1.7dBi gain (5500 ~ 5700MHz)
ANTENNA CONNECTOR	NA
DATA CABLE	NA
I/O PORTS	Refer to user's manual
ACCESSORY DEVICES	Refer to Note

NOTE:

- The EUT uses following accessories.

No.	Product	Brand	MODEL	Description
1	Power adapter	Panasonic	JT-H300AD-11	I/P: 100-240Vac, 220mA O/P: 5.0Vdc, 1600mA DC 1.4m shielded cable with 1 core
2	Battery	Panasonic	JT-B1-BT000U	Rating: 3.7 Vdc, 5720mAh Type: Li-ion
3	USB cable	Mitsumi	ADP-717SR	1.2m shielded cable with 2 cores

- The above EUT information is declared by manufacturer and for more detailed features description, please refer to the manufacturer's specifications or user's manual.

3.2 DESCRIPTION OF TEST MODES

FOR 5180 ~ 5240MHz

4 channels are provided for 802.11a, 802.11n (20MHz):

CHANNEL	FREQUENCY	CHANNEL	FREQUENCY
36	5180 MHz	44	5220 MHz
40	5200 MHz	48	5240 MHz

FOR 5260 ~ 5320MHz

4 channels are provided for 802.11a, 802.11n (20MHz):

CHANNEL	FREQUENCY	CHANNEL	FREQUENCY
52	5260 MHz	60	5300 MHz
56	5280 MHz	64	5320 MHz

FOR 5500 ~ 5700MHz

8 channels are provided for 802.11a, 802.11n (20MHz):

CHANNEL	FREQUENCY	CHANNEL	FREQUENCY
100	5500 MHz	116	5580 MHz
104	5520 MHz	132	5660 MHz
108	5540 MHz	136	5680 MHz
112	5560 MHz	140	5700 MHz

3.2.1 TEST MODE APPLICABILITY AND TESTED CHANNEL DETAIL

EUT CONFIGURE MODE	APPLICABLE TO				DESCRIPTION
	RE \geq 1G	RE<1G	PLC	APCM	
-	√	√	√	√	-

Where **RE \geq 1G**: Radiated Emission above 1GHz **RE<1G**: Radiated Emission below 1GHz
PLC: Power Line Conducted Emission **APCM**: Antenna Port Conducted Measurement

NOTE: The EUT had been pre-tested on the positioned of each 3 axis. The worst case was found when positioned on **Y-plane**.

RADIATED EMISSION TEST (ABOVE 1GHz):

- Pre-Scan has been conducted to determine the worst-case mode from all possible combinations between available modulations, data rates and antenna ports (if EUT with antenna diversity architecture).
- Following channel(s) was (were) selected for the final test as listed below.

EUT CONFIGURE MODE	MODE	FREQ. BAND (MHz)	AVAILABLE CHANNEL	TESTED CHANNEL	MODULATION TECHNOLOGY	MODULATION TYPE	DATA RATE (Mbps)
-	802.11a	5180-5240	36 to 48	36, 40, 48	OFDM	BPSK	6.0
-	802.11n (20MHz)		36 to 48	36, 40, 48	OFDM	BPSK	6.5
-	802.11a	5260-5320	52 to 64	52, 60, 64	OFDM	BPSK	6.0
-	802.11n (20MHz)		52 to 64	52, 60, 64	OFDM	BPSK	6.5
-	802.11a	5500-5700	100 to 140	100, 116, 140	OFDM	BPSK	6.0
-	802.11n (20MHz)		100 to 140	100, 116, 140	OFDM	BPSK	6.5

RADIATED EMISSION TEST (BELOW 1GHz):

- Pre-Scan has been conducted to determine the worst-case mode from all possible combinations between available modulations, data rates and antenna ports (if EUT with antenna diversity architecture).
- Following channel(s) was (were) selected for the final test as listed below.

EUT CONFIGURE MODE	MODE	FREQ. BAND (MHz)	AVAILABLE CHANNEL	TESTED CHANNEL	MODULATION TECHNOLOGY	MODULATION TYPE	DATA RATE (Mbps)
-	802.11a	5180-5320	36 to 64	36	OFDM	BPSK	6.0
-	802.11a	5500-5700	100 to 140	100	OFDM	BPSK	6.0

POWER LINE CONDUCTED EMISSION TEST:

- Pre-Scan has been conducted to determine the worst-case mode from all possible combinations between available modulations, data rates and antenna ports (if EUT with antenna diversity architecture).
- Following channel(s) was (were) selected for the final test as listed below.

EUT CONFIGURE MODE	MODE	FREQ. BAND (MHz)	AVAILABLE CHANNEL	TESTED CHANNEL	MODULATION TECHNOLOGY	MODULATION TYPE	DATA RATE (Mbps)
-	802.11a	5180-5320	36 to 64	36	OFDM	BPSK	6.0
-	802.11a	5500-5700	100 to 140	100	OFDM	BPSK	6.0

ANTENNA PORT CONDUCTED MEASUREMENT:

- This item includes all test value of each mode, but only includes spectrum plot of worst value of each mode.
- Pre-Scan has been conducted to determine the worst-case mode from all possible combinations between available modulations, data rates and antenna ports (if EUT with antenna diversity architecture).
- Following channel(s) was (were) selected for the final test as listed below.

EUT CONFIGURE MODE	MODE	FREQ. BAND (MHz)	AVAILABLE CHANNEL	TESTED CHANNEL	MODULATION TECHNOLOGY	MODULATION TYPE	DATA RATE (Mbps)
-	802.11a	5180-5240	36 to 48	36, 40, 48	OFDM	BPSK	6.0
-	802.11n (20MHz)		36 to 48	36, 40, 48	OFDM	BPSK	6.5
-	802.11a	5260-5320	52 to 64	52, 60, 64	OFDM	BPSK	6.0
-	802.11n (20MHz)		52 to 64	52, 60, 64	OFDM	BPSK	6.5
-	802.11a	5500-5700	100 to 140	100, 116, 140	OFDM	BPSK	6.0
-	802.11n (20MHz)		100 to 140	100, 116, 140	OFDM	BPSK	6.5

TEST CONDITION:

APPLICABLE TO	ENVIRONMENTAL CONDITIONS	INPUT POWER	TESTED BY
RE≥1G	24deg. C, 67%RH	120Vac, 60Hz	Cedric Wu
RE<1G	24deg. C, 67%RH	120Vac, 60Hz	Cedric Wu
PLC	25deg. C, 65%RH	120Vac, 60Hz	Cedric Wu
APCM	24deg. C, 75%RH	120Vac, 60Hz	Nick Chen

3.3 DUTY CYCLE OF TEST SIGNAL

If duty cycle is < 98%, duty factor shall be considered.

802.11a: Duty cycle = $2.063/2.115 = 0.975$, Duty factor = $10 * \log(1/0.975) = 0.11$

802.11n (20MHz): Duty cycle = $1.919/1.971 = 0.974$, Duty factor = $10 * \log(1/0.974) = 0.11$

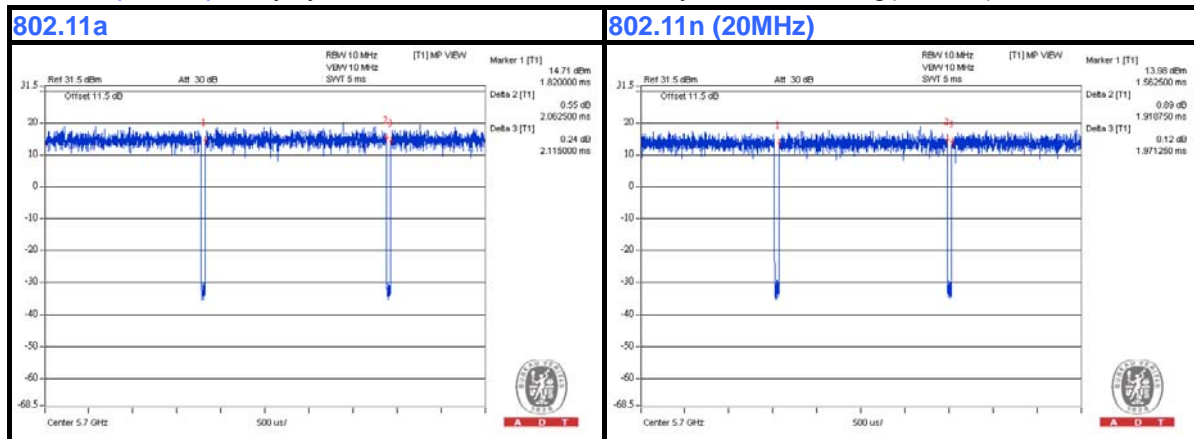

3.4 DESCRIPTION OF SUPPORT UNITS

The EUT has been tested as an independent unit together with other necessary accessories or support units. The following support units or accessories were used to form a representative test configuration during the tests.

NO.	PRODUCT	BRAND	MODEL NO.	SERIAL NO.	FCC ID
1	Notebook	DELL	D531	CN-0XM006-48643-81 U-2610	QDS-BRCM1020

NO.	SIGNAL CABLE DESCRIPTION OF THE ABOVE SUPPORT UNITS
1	NA

NOTE: All power cords of the above support units are non shielded (1.8m).

3.4.1 CONFIGURATION OF SYSTEM UNDER TEST

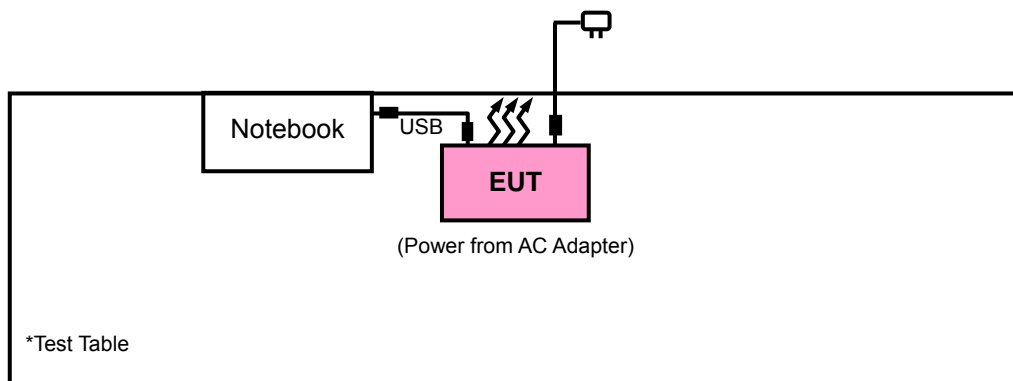

3.5 GENERAL DESCRIPTION OF APPLIED STANDARDS

The EUT is a RF Product. According to the specifications of the manufacturer, it must comply with the requirements of the following standards:

FCC Part 15, Subpart E (15.407)

789033 D01 General UNII Test Procedures v01 r02

ANSI C63.10-2009

All test items have been performed and recorded as per the above standards.

NOTE: The EUT is also considered as a kind of computer peripheral, because the connection to computer is necessary for typical use. It has been verified to comply with the requirements of FCC Part 15, Subpart B, Class B (DoC). The test report has been issued separately.

4. TEST TYPES AND RESULTS

4.1 RADIATED EMISSION AND BANDEDGE MEASUREMENT

4.1.1 LIMITS OF RADIATED EMISSION AND BANDEDGE MEASUREMENT

Radiated emissions which fall in the restricted bands must comply with the radiated emission limits specified as below table:

FREQUENCIES (MHz)	FIELD STRENGTH (microvolts/meter)	MEASUREMENT DISTANCE (meters)
0.009 ~ 0.490	2400/F(kHz)	300
0.490 ~ 1.705	24000/F(kHz)	30
1.705 ~ 30.0	30	30
30 ~ 88	100	3
88 ~ 216	150	3
216 ~ 960	200	3
Above 960	500	3

NOTE:

1. The lower limit shall apply at the transition frequencies.
2. Emission level (dBuV/m) = 20 log Emission level (uV/m).
3. For frequencies above 1000MHz, the field strength limits are based on average detector, however, the peak field strength of any emission shall not exceed the maximum permitted average limits, specified above by more than 20dB under any condition of modulation.

4.1.2 LIMITS OF UNWANTED EMISSION OUT OF THE RESTRICTED BANDS

APPLICABLE TO	LIMIT	
√	FIELD STRENGTH AT 3m (dBμV/m)	
	PK	AV
	74	54
	EIRP LIMIT (dBm)	EQUIVALENT FIELD STRENGTH AT 3m (dBμV/m)
	PK	PK
	-27	68.3

NOTE: The following formula is used to convert the equipment isotropic radiated power (eirp) to field strength:

$$E = \frac{1000000\sqrt{30P}}{3} \mu\text{V/m, where P is the eirp (Watts).}$$

4.1.3 TEST INSTRUMENTS

Tested date of Antenna Port Conducted Measurement: Nov. 15, 2012

DESCRIPTION & MANUFACTURER	MODEL NO.	SERIAL NO.	DATE OF CALIBRATION	DUE DATE OF CALIBRATION
Test Receiver ROHDE & SCHWARZ	ESCI	100744	Apr. 19, 2012	Apr. 18, 2013
Spectrum Analyzer ROHDE & SCHWARZ	FSP40	100269	Jan. 30, 2012	Jan. 29, 2013
BILOG Antenna SCHWARZBECK	VULB9168	9168-156	Apr. 03, 2012	Apr. 02, 2013
HORN Antenna SCHWARZBECK	BBHA 9120 D	9120D-563	Sep. 12, 2012	Sep. 11, 2013
HORN Antenna SCHWARZBECK	BBHA 9170	148	Jul. 11, 2012	Jul. 10, 2013
Loop Antenna	HFH2-Z2	100070	Jan. 31, 2012	Jan. 30, 2014
Preamplifier Agilent	8449B	3008A01911	Oct. 25, 2012	Oct. 24, 2013
Preamplifier Agilent	8447D	2944A10638	Oct. 25, 2012	Oct. 24, 2013
RF signal cable HUBER+SUHNNER	SUCOFLEX 104	295013/4 283403/4	Aug. 28, 2012	Aug. 27, 2013
RF signal cable Worken	8D-FB	Cable-HYCH9-01	Aug. 11, 2012	Aug. 10, 2013
Software	ADT_Radiated_ V7.6.15.9.2	NA	NA	NA
Antenna Tower EMCO	2070/2080	512.835.4684	NA	NA
Turn Table EMCO	2087-2.03	NA	NA	NA
Antenna Tower & Turn Table Controller EMCO	2090	NA	NA	NA
High Speed Peak Power Meter	ML2495A	0842014	Apr. 28, 2012	Apr. 27, 2013
Power Sensor	MA2411B	0738404	Apr. 28, 2012	Apr. 27, 2013

- NOTE:**
1. The calibration interval of the above test instruments is 12 months and the calibrations are traceable to NML/ROC and NIST/USA.
 2. The calibration interval of the loop antenna is 24 months and the calibrations are traceable to NML/ROC and NIST/USA.
 3. The test was performed in HwaYa Chamber 9.
 4. The horn antenna and HP preamplifier (model: 8449B) are used only for the measurement of emission frequency above 1GHz if tested.
 5. The FCC Site Registration No. is 460141.
 6. The IC Site Registration No. is IC 7450F-4.



Tested date of Radiated Emission, Power Line Conducted Emission: Dec. 20 ~ Dec. 26, 2012

DESCRIPTION & MANUFACTURER	MODEL NO.	SERIAL NO.	DATE OF CALIBRATION	DUE DATE OF CALIBRATION
Test Receiver ROHDE & SCHWARZ	ESI7	838496/016	Jan. 03, 2012	Jan. 02, 2013
Spectrum Analyzer ROHDE & SCHWARZ	FSP 40	100039	Feb. 03, 2012	Feb. 02, 2013
BILOG Antenna SCHWARZBECK	VULB9168	9168-155	Apr. 06, 2012	Apr. 05, 2013
HORN Antenna SCHWARZBECK	BBHA 9120D	9120D-408	Jan. 05, 2012	Jan. 04, 2013
HORN Antenna SCHWARZBECK	BBHA 9170	148	Jul. 11, 2012	Jul. 10, 2013
Loop Antenna	HFH2-Z2	100070	Jan. 31, 2012	Jan. 30, 2014
Preamplifier Agilent	8449B	3008A01961	Oct. 25, 2012	Oct. 24, 2013
Preamplifier Agilent	8447D	2944A10738	Oct. 23, 2012	Oct. 22, 2013
RF signal cable HUBER+SUHNNER	SUCOFLEX 104	309220/4	Aug. 28, 2012	Aug. 27, 2013
RF signal cable HUBER+SUHNNER	SUCOFLEX 104	250724/4	Aug. 28, 2012	Aug. 27, 2013
RF signal cable HUBER+SUHNNER	SUCOFLEX 104	295012/4	Aug. 28, 2012	Aug. 27, 2013
Software ADT	ADT_Radiated_ V7.6.15.9.2	NA	NA	NA
Antenna Tower inn-co GmbH	MA 4000	010303	NA	NA
Antenna Tower Controller inn-co GmbH	CO2000	019303	NA	NA
Turn Table ADT	TT100.	TT93021704	NA	NA
Turn Table Controller ADT	SC100.	SC93021704	NA	NA
High Speed Peak Power Meter	ML2495A	0842014	Apr. 28, 2012	Apr. 27, 2013
Power Sensor	MA2411B	0738404	Apr. 28, 2012	Apr. 27, 2013

- NOTE:**
1. The calibration interval of the above test instruments is 12 months and the calibrations are traceable to NML/ROC and NIST/USA.
 2. The calibration interval of the loop antenna is 24 months and the calibrations are traceable to NML/ROC and NIST/USA.
 3. The test was performed in HwaYa Chamber 4.
 4. The horn antenna and HP preamplifier (model: 8449B) are used only for the measurement of emission frequency above 1GHz if tested.
 5. The FCC Site Registration No. is 460141.
 6. The IC Site Registration No. is IC7450F-4.

4.1.4 TEST PROCEDURES

- a. The EUT was placed on the top of a rotating table 0.8 meters above the ground at a 3 meter semi-anechoic chamber. The table was rotated 360 degrees to determine the position of the highest radiation.
- b. The EUT was set 3 meters away from the interference-receiving antenna, which was mounted on the top of a variable-height antenna tower.
- c. The antenna is a broadband antenna, and its height is varied from one meter to four meters above the ground to determine the maximum value of the field strength. Both horizontal and vertical polarizations of the antenna are set to make the measurement.
- d. For each suspected emission, the EUT was arranged to its worst case and then the antenna was tuned to heights from 1 meter to 4 meters and the rotatable table was turned from 0 degrees to 360 degrees to find the maximum reading.
- e. The test-receiver system was set to Peak Detect Function and Specified Bandwidth with Maximum Hold Mode.
- f. If the emission level of the EUT in peak mode was 10dB lower than the limit specified, then testing could be stopped and the peak values of the EUT would be reported. Otherwise the emissions that did not have 10dB margin would be re-tested one by one using peak, quasi-peak or average method as specified and then reported in a data sheet.

NOTE:

1. The resolution bandwidth and video bandwidth of test receiver/spectrum analyzer is 120kHz for Peak detection (PK) and Quasi-peak detection (QP) at frequency below 1GHz.
2. The resolution bandwidth of test receiver/spectrum analyzer is 1MHz and video bandwidth is 3MHz for Peak detection at frequency above 1GHz.
3. The resolution bandwidth of test receiver/spectrum analyzer is 1MHz and the video bandwidth is 1kHz for Average detection (AV) at frequency above 1GHz.
4. All modes of operation were investigated and the worst-case emissions are reported.

4.1.5 DEVIATION FROM TEST STANDARD

No deviation.

4.1.6 TEST SETUP

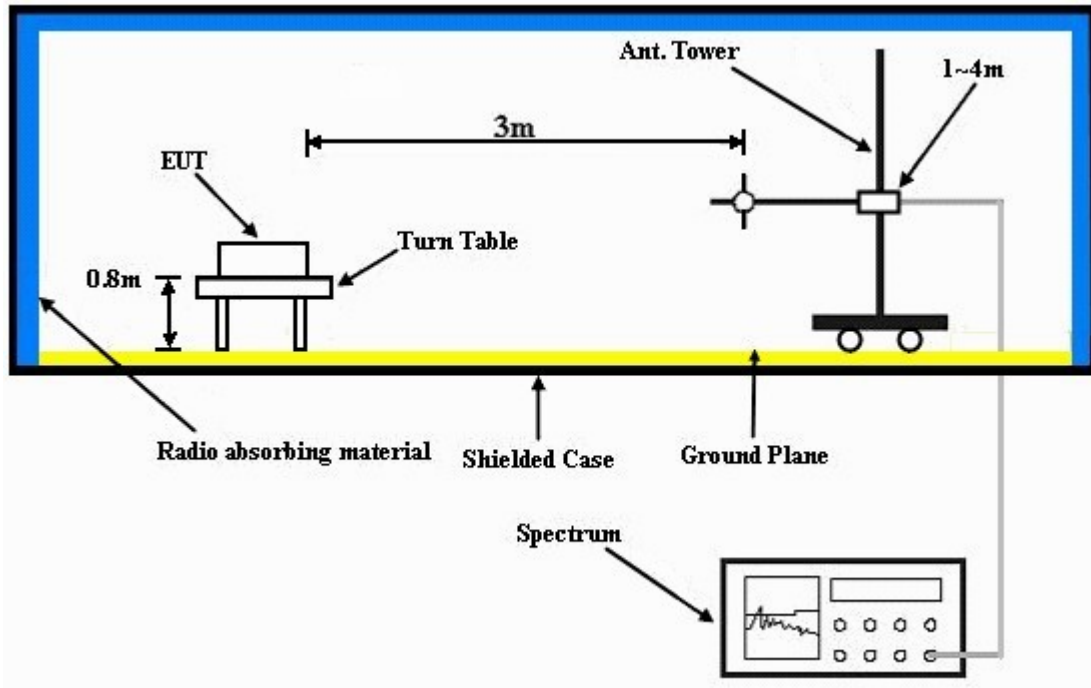

For the actual test configuration, please refer to the attached file (Test Setup Photo).

4.1.7 EUT OPERATING CONDITION

- Placed the EUT on a testing table.
- Use the software to control the EUT under transmission condition continuously at specific channel frequency.

4.1.8 TEST RESULTS

802.11a

EUT TEST CONDITION		MEASUREMENT DETAIL	
CHANNEL	Channel 36	FREQUENCY RANGE	1 ~ 40GHz
INPUT POWER (SYSTEM)	120Vac, 60Hz	DETECTOR FUNCTION	Peak (PK) Average (AV)
ENVIRONMENTAL CONDITIONS	24deg. C, 67%RH	TESTED BY	Cedric Wu

ANTENNA POLARITY & TEST DISTANCE: HORIZONTAL AT 3 M								
NO.	FREQ. (MHz)	EMISSION LEVEL (dBuV/m)	LIMIT (dBuV/m)	MARGIN (dB)	ANTENNA HEIGHT (m)	TABLE ANGLE (Degree)	RAW VALUE (dBuV)	CORRECTION FACTOR (dB/m)
1	5150.00	54.4 PK	74.0	-19.6	1.00 H	158	15.80	38.60
2	5150.00	41.6 AV	54.0	-12.4	1.00 H	158	3.00	38.60
3	*5180.00	100.1 PK			1.10 H	32	61.50	38.60
4	*5180.00	87.9 AV			1.10 H	32	49.30	38.60
5	#10360.00	56.7 PK	74.0	-17.3	1.00 H	300	7.20	49.50
6	#10360.00	43.9 AV	54.0	-10.1	1.00 H	300	-5.60	49.50
ANTENNA POLARITY & TEST DISTANCE: VERTICAL AT 3 M								
NO.	FREQ. (MHz)	EMISSION LEVEL (dBuV/m)	LIMIT (dBuV/m)	MARGIN (dB)	ANTENNA HEIGHT (m)	TABLE ANGLE (Degree)	RAW VALUE (dBuV)	CORRECTION FACTOR (dB/m)
1	5150.00	53.5 PK	74.0	-20.5	1.00 V	170	14.90	38.60
2	5150.00	40.8 AV	54.0	-13.2	1.00 V	170	2.20	38.60
3	*5180.00	98.6 PK			1.00 V	28	60.00	38.60
4	*5180.00	86.8 AV			1.00 V	28	48.20	38.60
5	#10360.00	56.1 PK	74.0	-17.9	1.00 V	120	6.60	49.50
6	#10360.00	43.2 AV	54.0	-10.8	1.00 V	120	-6.30	49.50

REMARKS:

1. Emission level (dBuV/m) = Raw Value (dBuV) + Correction Factor (dB/m).
2. Correction Factor (dB/m) = Antenna Factor (dB/m) + Cable Factor (dB).
3. The other emission levels were very low against the limit.
4. Margin value = Emission level – Limit value.
5. " * ": Fundamental frequency.
6. " # ": The radiated frequency is out of the restricted band.



A D T

EUT TEST CONDITION		MEASUREMENT DETAIL	
CHANNEL	Channel 40	FREQUENCY RANGE	1 ~ 40GHz
INPUT POWER (SYSTEM)	120Vac, 60Hz	DETECTOR FUNCTION	Peak (PK) Average (AV)
ENVIRONMENTAL CONDITIONS	24deg. C, 67%RH	TESTED BY	Cedric Wu

ANTENNA POLARITY & TEST DISTANCE: HORIZONTAL AT 3 M								
NO.	FREQ. (MHz)	EMISSION LEVEL (dBuV/m)	LIMIT (dBuV/m)	MARGIN (dB)	ANTENNA HEIGHT (m)	TABLE ANGLE (Degree)	RAW VALUE (dBuV)	CORRECTION FACTOR (dB/m)
1	*5200.00	99.7 PK			1.09 H	35	61.10	38.60
2	*5200.00	87.5 AV			1.09 H	35	48.90	38.60
3	#10400.00	57.1 PK	74.0	-16.9	1.00 H	311	7.60	49.50
4	#10400.00	44.2 AV	54.0	-9.8	1.00 H	311	-5.30	49.50
ANTENNA POLARITY & TEST DISTANCE: VERTICAL AT 3 M								
NO.	FREQ. (MHz)	EMISSION LEVEL (dBuV/m)	LIMIT (dBuV/m)	MARGIN (dB)	ANTENNA HEIGHT (m)	TABLE ANGLE (Degree)	RAW VALUE (dBuV)	CORRECTION FACTOR (dB/m)
1	*5200.00	98.2 PK			1.00 V	20	59.60	38.60
2	*5200.00	86.3 AV			1.00 V	20	47.70	38.60
3	#10400.00	56.5 PK	74.0	-17.5	1.00 V	122	7.00	49.50
4	#10400.00	43.7 AV	54.0	-10.3	1.00 V	122	-5.80	49.50

REMARKS:

1. Emission level (dBuV/m) = Raw Value (dBuV) + Correction Factor (dB/m).
2. Correction Factor (dB/m) = Antenna Factor (dB/m) + Cable Factor (dB).
3. The other emission levels were very low against the limit.
4. Margin value = Emission level – Limit value.
5. " * ": Fundamental frequency.
6. " # ": The radiated frequency is out of the restricted band.



A D T

EUT TEST CONDITION		MEASUREMENT DETAIL	
CHANNEL	Channel 48	FREQUENCY RANGE	1 ~ 40GHz
INPUT POWER (SYSTEM)	120Vac, 60Hz	DETECTOR FUNCTION	Peak (PK) Average (AV)
ENVIRONMENTAL CONDITIONS	24deg. C, 67%RH	TESTED BY	Cedric Wu

ANTENNA POLARITY & TEST DISTANCE: HORIZONTAL AT 3 M								
NO.	FREQ. (MHz)	EMISSION LEVEL (dBuV/m)	LIMIT (dBuV/m)	MARGIN (dB)	ANTENNA HEIGHT (m)	TABLE ANGLE (Degree)	RAW VALUE (dBuV)	CORRECTION FACTOR (dB/m)
1	*5240.00	100.4 PK			1.20 H	31	61.70	38.70
2	*5240.00	88.6 AV			1.20 H	31	49.90	38.70
3	5350.00	56.2 PK	74.0	-17.8	1.20 H	35	17.40	38.80
4	5350.00	43.9 AV	54.0	-10.1	1.20 H	35	5.10	38.80
5	#10480.00	56.5 PK	74.0	-17.5	1.00 H	298	6.80	49.70
6	#10480.00	43.7 AV	54.0	-10.3	1.00 H	298	-6.00	49.70
ANTENNA POLARITY & TEST DISTANCE: VERTICAL AT 3 M								
NO.	FREQ. (MHz)	EMISSION LEVEL (dBuV/m)	LIMIT (dBuV/m)	MARGIN (dB)	ANTENNA HEIGHT (m)	TABLE ANGLE (Degree)	RAW VALUE (dBuV)	CORRECTION FACTOR (dB/m)
1	*5240.00	98.9 PK			1.00 V	15	60.20	38.70
2	*5240.00	86.5 AV			1.00 V	15	47.80	38.70
3	5350.00	56.1 PK	74.0	-17.9	1.00 V	17	17.30	38.80
4	5350.00	43.7 AV	54.0	-10.3	1.00 V	17	4.90	38.80
5	#10480.00	55.9 PK	74.0	-18.1	1.00 V	114	6.20	49.70
6	#10480.00	42.9 AV	54.0	-11.1	1.00 V	114	-6.80	49.70

REMARKS:

1. Emission level (dBuV/m) = Raw Value (dBuV) + Correction Factor (dB/m).
2. Correction Factor (dB/m) = Antenna Factor (dB/m) + Cable Factor (dB).
3. The other emission levels were very low against the limit.
4. Margin value = Emission level – Limit value.
5. " * ": Fundamental frequency.
6. " # ": The radiated frequency is out of the restricted band.



A D T

EUT TEST CONDITION		MEASUREMENT DETAIL	
CHANNEL	Channel 52	FREQUENCY RANGE	1 ~ 40GHz
INPUT POWER (SYSTEM)	120Vac, 60Hz	DETECTOR FUNCTION	Peak (PK) Average (AV)
ENVIRONMENTAL CONDITIONS	24deg. C, 67%RH	TESTED BY	Cedric Wu

ANTENNA POLARITY & TEST DISTANCE: HORIZONTAL AT 3 M								
NO.	FREQ. (MHz)	EMISSION LEVEL (dBuV/m)	LIMIT (dBuV/m)	MARGIN (dB)	ANTENNA HEIGHT (m)	TABLE ANGLE (Degree)	RAW VALUE (dBuV)	CORRECTION FACTOR (dB/m)
1	5150.00	55.6 PK	74.0	-18.4	1.08 H	33	17.00	38.60
2	5150.00	43.3 AV	54.0	-10.7	1.08 H	33	4.70	38.60
3	*5260.00	101.1 PK			1.09 H	31	62.40	38.70
4	*5260.00	89.4 AV			1.09 H	31	50.70	38.70
5	#10520.00	56.4 PK	74.0	-17.6	1.00 H	333	6.60	49.80
6	#10520.00	45.0 AV	54.0	-9.0	1.00 H	333	-4.80	49.80
ANTENNA POLARITY & TEST DISTANCE: VERTICAL AT 3 M								
NO.	FREQ. (MHz)	EMISSION LEVEL (dBuV/m)	LIMIT (dBuV/m)	MARGIN (dB)	ANTENNA HEIGHT (m)	TABLE ANGLE (Degree)	RAW VALUE (dBuV)	CORRECTION FACTOR (dB/m)
1	5150.00	55.6 PK	74.0	-18.4	1.00 V	22	17.00	38.60
2	5150.00	42.8 AV	54.0	-11.2	1.00 V	22	4.20	38.60
3	*5260.00	98.9 PK			1.00 V	18	60.20	38.70
4	*5260.00	86.7 AV			1.00 V	18	48.00	38.70
5	#10520.00	56.8 PK	74.0	-17.2	1.00 V	98	7.00	49.80
6	#10520.00	44.4 AV	54.0	-9.6	1.00 V	98	-5.40	49.80

REMARKS:

1. Emission level (dBuV/m) = Raw Value (dBuV) + Correction Factor (dB/m).
2. Correction Factor (dB/m) = Antenna Factor (dB/m) + Cable Factor (dB).
3. The other emission levels were very low against the limit.
4. Margin value = Emission level – Limit value.
5. " * " : Fundamental frequency.
6. " # " : The radiated frequency is out of the restricted band.



A D T

EUT TEST CONDITION		MEASUREMENT DETAIL	
CHANNEL	Channel 60	FREQUENCY RANGE	1 ~ 40GHz
INPUT POWER (SYSTEM)	120Vac, 60Hz	DETECTOR FUNCTION	Peak (PK) Average (AV)
ENVIRONMENTAL CONDITIONS	24deg. C, 67%RH	TESTED BY	Cedric Wu

ANTENNA POLARITY & TEST DISTANCE: HORIZONTAL AT 3 M								
NO.	FREQ. (MHz)	EMISSION LEVEL (dBuV/m)	LIMIT (dBuV/m)	MARGIN (dB)	ANTENNA HEIGHT (m)	TABLE ANGLE (Degree)	RAW VALUE (dBuV)	CORRECTION FACTOR (dB/m)
1	*5300.00	103.0 PK			1.07 H	31	64.20	38.80
2	*5300.00	90.8 AV			1.07 H	31	52.00	38.80
3	10600.00	56.9 PK	74.0	-17.1	1.00 H	337	6.90	50.00
4	10600.00	45.6 AV	54.0	-8.4	1.00 H	337	-4.40	50.00
ANTENNA POLARITY & TEST DISTANCE: VERTICAL AT 3 M								
NO.	FREQ. (MHz)	EMISSION LEVEL (dBuV/m)	LIMIT (dBuV/m)	MARGIN (dB)	ANTENNA HEIGHT (m)	TABLE ANGLE (Degree)	RAW VALUE (dBuV)	CORRECTION FACTOR (dB/m)
1	*5300.00	98.5 PK			1.00 V	18	59.70	38.80
2	*5300.00	86.2 AV			1.00 V	18	47.40	38.80
3	10600.00	57.3 PK	74.0	-16.7	1.00 V	104	7.30	50.00
4	10600.00	44.9 AV	54.0	-9.1	1.00 V	104	-5.10	50.00

REMARKS:

1. Emission level (dBuV/m) = Raw Value (dBuV) + Correction Factor (dB/m).
2. Correction Factor (dB/m) = Antenna Factor (dB/m) + Cable Factor (dB).
3. The other emission levels were very low against the limit.
4. Margin value = Emission level – Limit value.
5. " * ": Fundamental frequency.



EUT TEST CONDITION		MEASUREMENT DETAIL	
CHANNEL	Channel 64	FREQUENCY RANGE	1 ~ 40GHz
INPUT POWER (SYSTEM)	120Vac, 60Hz	DETECTOR FUNCTION	Peak (PK) Average (AV)
ENVIRONMENTAL CONDITIONS	24deg. C, 67%RH	TESTED BY	Cedric Wu

ANTENNA POLARITY & TEST DISTANCE: HORIZONTAL AT 3 M								
NO.	FREQ. (MHz)	EMISSION LEVEL (dBuV/m)	LIMIT (dBuV/m)	MARGIN (dB)	ANTENNA HEIGHT (m)	TABLE ANGLE (Degree)	RAW VALUE (dBuV)	CORRECTION FACTOR (dB/m)
1	*5320.00	102.5 PK			1.07 H	35	63.70	38.80
2	*5320.00	90.6 AV			1.07 H	35	51.80	38.80
3	5350.00	56.7 PK	74.0	-17.3	1.08 H	31	17.90	38.80
4	5350.00	43.3 AV	54.0	-10.7	1.08 H	31	4.50	38.80
5	10640.00	56.0 PK	74.0	-18.0	1.00 H	329	5.80	50.20
6	10640.00	47.7 AV	54.0	-6.3	1.00 H	329	-2.50	50.20
ANTENNA POLARITY & TEST DISTANCE: VERTICAL AT 3 M								
NO.	FREQ. (MHz)	EMISSION LEVEL (dBuV/m)	LIMIT (dBuV/m)	MARGIN (dB)	ANTENNA HEIGHT (m)	TABLE ANGLE (Degree)	RAW VALUE (dBuV)	CORRECTION FACTOR (dB/m)
1	*5320.00	97.7 PK			1.11 V	17	58.90	38.80
2	*5320.00	85.6 AV			1.11 V	17	46.80	38.80
3	5350.00	56.8 PK	74.0	-17.2	1.05 V	18	18.00	38.80
4	5350.00	43.1 AV	54.0	-10.9	1.05 V	18	4.30	38.80
5	10640.00	56.5 PK	74.0	-17.5	1.00 V	91	6.30	50.20
6	10640.00	44.2 AV	54.0	-9.8	1.00 V	91	-6.00	50.20

REMARKS:

1. Emission level (dBuV/m) = Raw Value (dBuV) + Correction Factor (dB/m).
2. Correction Factor (dB/m) = Antenna Factor (dB/m) + Cable Factor (dB).
3. The other emission levels were very low against the limit.
4. Margin value = Emission level – Limit value.
5. " * " : Fundamental frequency.
6. " # " : The radiated frequency is out of the restricted band.



A D T

EUT TEST CONDITION		MEASUREMENT DETAIL	
CHANNEL	Channel 100	FREQUENCY RANGE	1 ~ 40GHz
INPUT POWER (SYSTEM)	120Vac, 60Hz	DETECTOR FUNCTION	Peak (PK) Average (AV)
ENVIRONMENTAL CONDITIONS	24deg. C, 67%RH	TESTED BY	Cedric Wu

ANTENNA POLARITY & TEST DISTANCE: HORIZONTAL AT 3 M								
NO.	FREQ. (MHz)	EMISSION LEVEL (dBuV/m)	LIMIT (dBuV/m)	MARGIN (dB)	ANTENNA HEIGHT (m)	TABLE ANGLE (Degree)	RAW VALUE (dBuV)	CORRECTION FACTOR (dB/m)
1	5460.00	57.3 PK	74.0	-16.7	1.21 H	96	18.30	39.00
2	5460.00	43.4 AV	54.0	-10.6	1.21 H	96	4.40	39.00
3	#5470.00	56.7 PK	74.0	-17.3	1.21 H	91	17.70	39.00
4	#5470.00	43.4 AV	54.0	-10.6	1.21 H	91	4.40	39.00
5	*5500.00	103.7 PK			1.21 H	87	64.60	39.10
6	*5500.00	91.1 AV			1.21 H	87	52.00	39.10
7	11000.00	58.2 PK	74.0	-15.8	1.00 H	339	6.60	51.60
8	11000.00	45.6 AV	54.0	-8.4	1.00 H	339	-6.00	51.60
ANTENNA POLARITY & TEST DISTANCE: VERTICAL AT 3 M								
NO.	FREQ. (MHz)	EMISSION LEVEL (dBuV/m)	LIMIT (dBuV/m)	MARGIN (dB)	ANTENNA HEIGHT (m)	TABLE ANGLE (Degree)	RAW VALUE (dBuV)	CORRECTION FACTOR (dB/m)
1	5460.00	56.9 PK	74.0	-17.1	1.00 V	98	17.90	39.00
2	5460.00	43.1 AV	54.0	-10.9	1.00 V	98	4.10	39.00
3	#5470.00	56.3 PK	74.0	-17.7	1.00 V	100	17.30	39.00
4	#5470.00	42.9 AV	54.0	-11.1	1.00 V	100	3.90	39.00
5	*5500.00	98.0 PK			1.00 V	96	58.90	39.10
6	*5500.00	85.9 AV			1.00 V	96	46.80	39.10
7	11000.00	57.4 PK	74.0	-16.6	1.00 V	166	5.80	51.60
8	11000.00	45.0 AV	54.0	-9.0	1.00 V	166	-6.60	51.60

REMARKS:

1. Emission level (dBuV/m) = Raw Value (dBuV) + Correction Factor (dB/m).
2. Correction Factor (dB/m) = Antenna Factor (dB/m) + Cable Factor (dB).
3. The other emission levels were very low against the limit.
4. Margin value = Emission level – Limit value.
5. " * ": Fundamental frequency.
6. " # ": The radiated frequency is out of the restricted band.



A D T

EUT TEST CONDITION		MEASUREMENT DETAIL	
CHANNEL	Channel 116	FREQUENCY RANGE	1 ~ 40GHz
INPUT POWER (SYSTEM)	120Vac, 60Hz	DETECTOR FUNCTION	Peak (PK) Average (AV)
ENVIRONMENTAL CONDITIONS	24deg. C, 67%RH	TESTED BY	Cedric Wu

ANTENNA POLARITY & TEST DISTANCE: HORIZONTAL AT 3 M								
NO.	FREQ. (MHz)	EMISSION LEVEL (dBuV/m)	LIMIT (dBuV/m)	MARGIN (dB)	ANTENNA HEIGHT (m)	TABLE ANGLE (Degree)	RAW VALUE (dBuV)	CORRECTION FACTOR (dB/m)
1	*5580.00	103.2 PK			1.10 H	86	64.00	39.20
2	*5580.00	91.2 AV			1.10 H	86	52.00	39.20
3	11160.00	58.4 PK	74.0	-15.6	1.00 H	346	7.10	51.30
4	11160.00	45.9 AV	54.0	-8.1	1.00 H	346	-5.40	51.30
ANTENNA POLARITY & TEST DISTANCE: VERTICAL AT 3 M								
NO.	FREQ. (MHz)	EMISSION LEVEL (dBuV/m)	LIMIT (dBuV/m)	MARGIN (dB)	ANTENNA HEIGHT (m)	TABLE ANGLE (Degree)	RAW VALUE (dBuV)	CORRECTION FACTOR (dB/m)
1	*5580.00	96.2 PK			1.00 V	107	57.00	39.20
2	*5580.00	84.0 AV			1.00 V	107	44.80	39.20
3	11160.00	57.6 PK	74.0	-16.4	1.00 V	170	6.30	51.30
4	11160.00	45.3 AV	54.0	-8.7	1.00 V	170	-6.00	51.30

REMARKS:

1. Emission level (dBuV/m) = Raw Value (dBuV) + Correction Factor (dB/m).
2. Correction Factor (dB/m) = Antenna Factor (dB/m) + Cable Factor (dB).
3. The other emission levels were very low against the limit.
4. Margin value = Emission level – Limit value.
5. " * ": Fundamental frequency.



A D T

EUT TEST CONDITION		MEASUREMENT DETAIL	
CHANNEL	Channel 140	FREQUENCY RANGE	1 ~ 40GHz
INPUT POWER (SYSTEM)	120Vac, 60Hz	DETECTOR FUNCTION	Peak (PK) Average (AV)
ENVIRONMENTAL CONDITIONS	24deg. C, 67%RH	TESTED BY	Cedric Wu

ANTENNA POLARITY & TEST DISTANCE: HORIZONTAL AT 3 M								
NO.	FREQ. (MHz)	EMISSION LEVEL (dBuV/m)	LIMIT (dBuV/m)	MARGIN (dB)	ANTENNA HEIGHT (m)	TABLE ANGLE (Degree)	RAW VALUE (dBuV)	CORRECTION FACTOR (dB/m)
1	*5700.00	100.8 PK			1.18 H	88	61.30	39.50
2	*5700.00	88.7 AV			1.18 H	88	49.20	39.50
3	#5725.00	55.5 PK	74.0	-18.5	1.19 H	90	16.00	39.50
4	#5725.00	42.8 AV	54.0	-11.2	1.19 H	90	3.30	39.50
5	11400.00	57.9 PK	74.0	-16.1	1.00 H	334	6.30	51.60
6	11400.00	45.3 AV	54.0	-8.7	1.00 H	334	-6.30	51.60
ANTENNA POLARITY & TEST DISTANCE: VERTICAL AT 3 M								
NO.	FREQ. (MHz)	EMISSION LEVEL (dBuV/m)	LIMIT (dBuV/m)	MARGIN (dB)	ANTENNA HEIGHT (m)	TABLE ANGLE (Degree)	RAW VALUE (dBuV)	CORRECTION FACTOR (dB/m)
1	*5700.00	95.6 PK			1.17 V	97	56.10	39.50
2	*5700.00	83.4 AV			1.17 V	97	43.90	39.50
3	#5725.00	55.1 PK	74.0	-18.9	1.15 V	99	15.60	39.50
4	#5725.00	42.3 AV	54.0	-11.7	1.15 V	99	2.80	39.50
5	11400.00	57.0 PK	74.0	-17.0	1.00 V	164	5.40	51.60
6	11400.00	44.8 AV	54.0	-9.2	1.00 V	164	-6.80	51.60

REMARKS:

1. Emission level (dBuV/m) = Raw Value (dBuV) + Correction Factor (dB/m).
2. Correction Factor (dB/m) = Antenna Factor (dB/m) + Cable Factor (dB).
3. The other emission levels were very low against the limit.
4. Margin value = Emission level – Limit value.
5. " * " : Fundamental frequency.
6. " # " : The radiated frequency is out of the restricted band.



A D T

802.11n (20MHz)

EUT TEST CONDITION		MEASUREMENT DETAIL	
CHANNEL	Channel 36	FREQUENCY RANGE	1 ~ 40GHz
INPUT POWER (SYSTEM)	120Vac, 60Hz	DETECTOR FUNCTION	Peak (PK) Average (AV)
ENVIRONMENTAL CONDITIONS	24deg. C, 67%RH	TESTED BY	Cedric Wu

ANTENNA POLARITY & TEST DISTANCE: HORIZONTAL AT 3 M								
NO.	FREQ. (MHz)	EMISSION LEVEL (dBUV/m)	LIMIT (dBUV/m)	MARGIN (dB)	ANTENNA HEIGHT (m)	TABLE ANGLE (Degree)	RAW VALUE (dBUV)	CORRECTION FACTOR (dB/m)
1	5150.00	56.1 PK	74.0	-17.9	1.00 H	37	17.50	38.60
2	5150.00	43.2 AV	54.0	-10.8	1.00 H	37	4.60	38.60
3	*5180.00	99.9 PK			1.00 H	35	61.30	38.60
4	*5180.00	87.7 AV			1.00 H	35	49.10	38.60
5	#10360.00	57.3 PK	74.0	-16.7	1.00 H	315	7.80	49.50
6	#10360.00	44.4 AV	54.0	-9.6	1.00 H	315	-5.10	49.50
ANTENNA POLARITY & TEST DISTANCE: VERTICAL AT 3 M								
NO.	FREQ. (MHz)	EMISSION LEVEL (dBUV/m)	LIMIT (dBUV/m)	MARGIN (dB)	ANTENNA HEIGHT (m)	TABLE ANGLE (Degree)	RAW VALUE (dBUV)	CORRECTION FACTOR (dB/m)
1	5150.00	55.5 PK	74.0	-18.5	1.00 V	14	16.90	38.60
2	5150.00	42.9 AV	54.0	-11.1	1.00 V	14	4.30	38.60
3	*5180.00	96.7 PK			1.00 V	18	58.10	38.60
4	*5180.00	84.6 AV			1.00 V	18	46.00	38.60
5	#10360.00	56.7 PK	74.0	-17.3	1.00 V	131	7.20	49.50
6	#10360.00	43.7 AV	54.0	-10.3	1.00 V	131	-5.80	49.50

REMARKS:

1. Emission level (dBUV/m) = Raw Value (dBUV) + Correction Factor (dB/m).
2. Correction Factor (dB/m) = Antenna Factor (dB/m) + Cable Factor (dB).
3. The other emission levels were very low against the limit.
4. Margin value = Emission level – Limit value.
5. " * ": Fundamental frequency.
6. " # ": The radiated frequency is out of the restricted band.



A D T

EUT TEST CONDITION		MEASUREMENT DETAIL	
CHANNEL	Channel 40	FREQUENCY RANGE	1 ~ 40GHz
INPUT POWER (SYSTEM)	120Vac, 60Hz	DETECTOR FUNCTION	Peak (PK) Average (AV)
ENVIRONMENTAL CONDITIONS	24deg. C, 67%RH	TESTED BY	Cedric Wu

ANTENNA POLARITY & TEST DISTANCE: HORIZONTAL AT 3 M								
NO.	FREQ. (MHz)	EMISSION LEVEL (dBuV/m)	LIMIT (dBuV/m)	MARGIN (dB)	ANTENNA HEIGHT (m)	TABLE ANGLE (Degree)	RAW VALUE (dBuV)	CORRECTION FACTOR (dB/m)
1	*5200.00	99.1 PK			1.07 H	34	60.50	38.60
2	*5200.00	87.2 AV			1.07 H	34	48.60	38.60
3	#10400.00	57.7 PK	74.0	-16.3	1.00 H	319	8.20	49.50
4	#10400.00	44.9 AV	54.0	-9.1	1.00 H	319	-4.60	49.50
ANTENNA POLARITY & TEST DISTANCE: VERTICAL AT 3 M								
NO.	FREQ. (MHz)	EMISSION LEVEL (dBuV/m)	LIMIT (dBuV/m)	MARGIN (dB)	ANTENNA HEIGHT (m)	TABLE ANGLE (Degree)	RAW VALUE (dBuV)	CORRECTION FACTOR (dB/m)
1	*5200.00	97.1 PK			1.00 V	17	58.50	38.60
2	*5200.00	85.2 AV			1.00 V	17	46.60	38.60
3	#10400.00	57.1 PK	74.0	-16.9	1.00 V	136	7.60	49.50
4	#10400.00	43.2 AV	54.0	-10.8	1.00 V	136	-6.30	49.50

REMARKS:

1. Emission level (dBuV/m) = Raw Value (dBuV) + Correction Factor (dB/m).
2. Correction Factor (dB/m) = Antenna Factor (dB/m) + Cable Factor (dB).
3. The other emission levels were very low against the limit.
4. Margin value = Emission level – Limit value.
5. " * ": Fundamental frequency.
6. " # ": The radiated frequency is out of the restricted band.



A D T

EUT TEST CONDITION		MEASUREMENT DETAIL	
CHANNEL	Channel 48	FREQUENCY RANGE	1 ~ 40GHz
INPUT POWER (SYSTEM)	120Vac, 60Hz	DETECTOR FUNCTION	Peak (PK) Average (AV)
ENVIRONMENTAL CONDITIONS	24deg. C, 67%RH	TESTED BY	Cedric Wu

ANTENNA POLARITY & TEST DISTANCE: HORIZONTAL AT 3 M								
NO.	FREQ. (MHz)	EMISSION LEVEL (dBuV/m)	LIMIT (dBuV/m)	MARGIN (dB)	ANTENNA HEIGHT (m)	TABLE ANGLE (Degree)	RAW VALUE (dBuV)	CORRECTION FACTOR (dB/m)
1	*5240.00	99.9 PK			1.08 H	29	61.20	38.70
2	*5240.00	88.0 AV			1.08 H	29	49.30	38.70
3	5350.00	56.6 PK	74.0	-17.4	1.07 H	25	17.80	38.80
4	5350.00	43.3 AV	54.0	-10.7	1.07 H	25	4.50	38.80
5	#10480.00	56.5 PK	74.0	-17.5	1.00 H	307	6.80	49.70
6	#10480.00	43.7 AV	54.0	-10.3	1.00 H	307	-6.00	49.70
ANTENNA POLARITY & TEST DISTANCE: VERTICAL AT 3 M								
NO.	FREQ. (MHz)	EMISSION LEVEL (dBuV/m)	LIMIT (dBuV/m)	MARGIN (dB)	ANTENNA HEIGHT (m)	TABLE ANGLE (Degree)	RAW VALUE (dBuV)	CORRECTION FACTOR (dB/m)
1	*5240.00	97.4 PK			1.00 V	15	58.70	38.70
2	*5240.00	85.0 AV			1.00 V	15	46.30	38.70
3	5350.00	56.3 PK	74.0	-17.7	1.02 V	15	17.50	38.80
4	5350.00	43.1 AV	54.0	-10.9	1.02 V	15	4.30	38.80
5	#10480.00	55.9 PK	74.0	-18.1	1.00 V	124	6.20	49.70
6	#10480.00	42.9 AV	54.0	-11.1	1.00 V	124	-6.80	49.70

REMARKS:

1. Emission level (dBuV/m) = Raw Value (dBuV) + Correction Factor (dB/m).
2. Correction Factor (dB/m) = Antenna Factor (dB/m) + Cable Factor (dB).
3. The other emission levels were very low against the limit.
4. Margin value = Emission level – Limit value.
5. " * ": Fundamental frequency.
6. " # ": The radiated frequency is out of the restricted band.



A D T

EUT TEST CONDITION		MEASUREMENT DETAIL	
CHANNEL	Channel 52	FREQUENCY RANGE	1 ~ 40GHz
INPUT POWER (SYSTEM)	120Vac, 60Hz	DETECTOR FUNCTION	Peak (PK) Average (AV)
ENVIRONMENTAL CONDITIONS	24deg. C, 67%RH	TESTED BY	Cedric Wu

ANTENNA POLARITY & TEST DISTANCE: HORIZONTAL AT 3 M								
NO.	FREQ. (MHz)	EMISSION LEVEL (dBuV/m)	LIMIT (dBuV/m)	MARGIN (dB)	ANTENNA HEIGHT (m)	TABLE ANGLE (Degree)	RAW VALUE (dBuV)	CORRECTION FACTOR (dB/m)
1	5150.00	55.6 PK	74.0	-18.4	1.05 H	31	17.00	38.60
2	5150.00	43.0 AV	54.0	-11.0	1.05 H	31	4.40	38.60
3	*5260.00	100.8 PK			1.08 H	30	62.10	38.70
4	*5260.00	88.5 AV			1.08 H	30	49.80	38.70
5	#10520.00	58.0 PK	74.0	-16.0	1.00 H	327	8.20	49.80
6	#10520.00	44.4 AV	54.0	-9.6	1.00 H	327	-5.40	49.80
ANTENNA POLARITY & TEST DISTANCE: VERTICAL AT 3 M								
NO.	FREQ. (MHz)	EMISSION LEVEL (dBuV/m)	LIMIT (dBuV/m)	MARGIN (dB)	ANTENNA HEIGHT (m)	TABLE ANGLE (Degree)	RAW VALUE (dBuV)	CORRECTION FACTOR (dB/m)
1	5150.00	54.8 PK	74.0	-19.2	1.00 V	23	16.20	38.60
2	5150.00	42.5 AV	54.0	-11.5	1.00 V	23	3.90	38.60
3	*5260.00	97.6 PK			1.00 V	18	58.90	38.70
4	*5260.00	85.5 AV			1.00 V	18	46.80	38.70
5	#10520.00	57.1 PK	74.0	-16.9	1.00 V	90	7.30	49.80
6	#10520.00	43.5 AV	54.0	-10.5	1.00 V	90	-6.30	49.80

REMARKS:

1. Emission level (dBuV/m) = Raw Value (dBuV) + Correction Factor (dB/m).
2. Correction Factor (dB/m) = Antenna Factor (dB/m) + Cable Factor (dB).
3. The other emission levels were very low against the limit.
4. Margin value = Emission level – Limit value.
5. " * ": Fundamental frequency.
6. " # ": The radiated frequency is out of the restricted band.



A D T

EUT TEST CONDITION		MEASUREMENT DETAIL	
CHANNEL	Channel 60	FREQUENCY RANGE	1 ~ 40GHz
INPUT POWER (SYSTEM)	120Vac, 60Hz	DETECTOR FUNCTION	Peak (PK) Average (AV)
ENVIRONMENTAL CONDITIONS	24deg. C, 67%RH	TESTED BY	Cedric Wu

ANTENNA POLARITY & TEST DISTANCE: HORIZONTAL AT 3 M								
NO.	FREQ. (MHz)	EMISSION LEVEL (dBuV/m)	LIMIT (dBuV/m)	MARGIN (dB)	ANTENNA HEIGHT (m)	TABLE ANGLE (Degree)	RAW VALUE (dBuV)	CORRECTION FACTOR (dB/m)
1	*5300.00	102.0 PK			1.07 H	29	63.20	38.80
2	*5300.00	89.4 AV			1.07 H	29	50.60	38.80
3	10600.00	58.4 PK	74.0	-15.6	1.00 H	334	8.40	50.00
4	10600.00	44.9 AV	54.0	-9.1	1.00 H	334	-5.10	50.00
ANTENNA POLARITY & TEST DISTANCE: VERTICAL AT 3 M								
NO.	FREQ. (MHz)	EMISSION LEVEL (dBuV/m)	LIMIT (dBuV/m)	MARGIN (dB)	ANTENNA HEIGHT (m)	TABLE ANGLE (Degree)	RAW VALUE (dBuV)	CORRECTION FACTOR (dB/m)
1	*5300.00	97.3 PK			1.00 V	18	58.50	38.80
2	*5300.00	85.1 AV			1.00 V	18	46.30	38.80
3	10600.00	57.7 PK	74.0	-16.3	1.00 V	104	7.70	50.00
4	10600.00	44.1 AV	54.0	-9.9	1.00 V	104	-5.90	50.00

REMARKS:

1. Emission level (dBuV/m) = Raw Value (dBuV) + Correction Factor (dB/m).
2. Correction Factor (dB/m) = Antenna Factor (dB/m) + Cable Factor (dB).
3. The other emission levels were very low against the limit.
4. Margin value = Emission level – Limit value.
5. " * ": Fundamental frequency.



A D T

EUT TEST CONDITION		MEASUREMENT DETAIL	
CHANNEL	Channel 64	FREQUENCY RANGE	1 ~ 40GHz
INPUT POWER (SYSTEM)	120Vac, 60Hz	DETECTOR FUNCTION	Peak (PK) Average (AV)
ENVIRONMENTAL CONDITIONS	24deg. C, 67%RH	TESTED BY	Cedric Wu

ANTENNA POLARITY & TEST DISTANCE: HORIZONTAL AT 3 M								
NO.	FREQ. (MHz)	EMISSION LEVEL (dBuV/m)	LIMIT (dBuV/m)	MARGIN (dB)	ANTENNA HEIGHT (m)	TABLE ANGLE (Degree)	RAW VALUE (dBuV)	CORRECTION FACTOR (dB/m)
1	*5320.00	101.7 PK			1.06 H	31	62.90	38.80
2	*5320.00	89.2 AV			1.06 H	31	50.40	38.80
3	5350.00	56.2 PK	74.0	-17.8	1.08 H	34	17.40	38.80
4	5350.00	43.3 AV	54.0	-10.7	1.08 H	34	4.50	38.80
5	10640.00	57.6 PK	74.0	-16.4	1.00 H	324	7.40	50.20
6	10640.00	43.9 AV	54.0	-10.1	1.00 H	324	-6.30	50.20
ANTENNA POLARITY & TEST DISTANCE: VERTICAL AT 3 M								
NO.	FREQ. (MHz)	EMISSION LEVEL (dBuV/m)	LIMIT (dBuV/m)	MARGIN (dB)	ANTENNA HEIGHT (m)	TABLE ANGLE (Degree)	RAW VALUE (dBuV)	CORRECTION FACTOR (dB/m)
1	*5320.00	97.4 PK			1.00 V	17	58.60	38.80
2	*5320.00	85.2 AV			1.00 V	17	46.40	38.80
3	5350.00	55.7 PK	74.0	-18.3	1.00 V	10	16.90	38.80
4	5350.00	42.9 AV	54.0	-11.1	1.00 V	10	4.10	38.80
5	10640.00	56.5 PK	74.0	-17.5	1.00 V	84	6.30	50.20
6	10640.00	43.1 AV	54.0	-10.9	1.00 V	84	-7.10	50.20

REMARKS:

1. Emission level (dBuV/m) = Raw Value (dBuV) + Correction Factor (dB/m).
2. Correction Factor (dB/m) = Antenna Factor (dB/m) + Cable Factor (dB).
3. The other emission levels were very low against the limit.
4. Margin value = Emission level – Limit value.
5. " * ": Fundamental frequency.



A D T

EUT TEST CONDITION		MEASUREMENT DETAIL	
CHANNEL	Channel 100	FREQUENCY RANGE	1 ~ 40GHz
INPUT POWER (SYSTEM)	120Vac, 60Hz	DETECTOR FUNCTION	Peak (PK) Average (AV)
ENVIRONMENTAL CONDITIONS	24deg. C, 67%RH	TESTED BY	Cedric Wu

ANTENNA POLARITY & TEST DISTANCE: HORIZONTAL AT 3 M								
NO.	FREQ. (MHz)	EMISSION LEVEL (dBuV/m)	LIMIT (dBuV/m)	MARGIN (dB)	ANTENNA HEIGHT (m)	TABLE ANGLE (Degree)	RAW VALUE (dBuV)	CORRECTION FACTOR (dB/m)
1	5460.00	56.2 PK	74.0	-17.8	1.24 H	88	17.20	39.00
2	5460.00	43.2 AV	54.0	-10.8	1.24 H	88	4.20	39.00
3	#5470.00	57.5 PK	74.0	-16.5	1.20 H	87	18.50	39.00
4	#5470.00	43.1 AV	54.0	-10.9	1.20 H	87	4.10	39.00
5	*5500.00	103.6 PK			1.22 H	86	64.50	39.10
6	*5500.00	91.1 AV			1.22 H	86	52.00	39.10
7	11000.00	58.9 PK	74.0	-15.1	1.00 H	340	7.30	51.60
8	11000.00	45.4 AV	54.0	-8.6	1.00 H	340	-6.20	51.60
ANTENNA POLARITY & TEST DISTANCE: VERTICAL AT 3 M								
NO.	FREQ. (MHz)	EMISSION LEVEL (dBuV/m)	LIMIT (dBuV/m)	MARGIN (dB)	ANTENNA HEIGHT (m)	TABLE ANGLE (Degree)	RAW VALUE (dBuV)	CORRECTION FACTOR (dB/m)
1	5460.00	56.0 PK	74.0	-18.0	1.00 V	106	17.00	39.00
2	5460.00	42.9 AV	54.0	-11.1	1.00 V	106	3.90	39.00
3	#5470.00	57.3 PK	74.0	-16.7	1.00 V	110	18.30	39.00
4	#5470.00	43.0 AV	54.0	-11.0	1.00 V	110	4.00	39.00
5	*5500.00	97.7 PK			1.00 V	108	58.60	39.10
6	*5500.00	86.0 AV			1.00 V	108	46.90	39.10
7	11000.00	58.2 PK	74.0	-15.8	1.00 V	180	6.60	51.60
8	11000.00	44.9 AV	54.0	-9.1	1.00 V	180	-6.70	51.60

REMARKS:

1. Emission level (dBuV/m) = Raw Value (dBuV) + Correction Factor (dB/m).
2. Correction Factor (dB/m) = Antenna Factor (dB/m) + Cable Factor (dB).
3. The other emission levels were very low against the limit.
4. Margin value = Emission level – Limit value.
5. " * ": Fundamental frequency.
6. " # ": The radiated frequency is out of the restricted band.



A D T

EUT TEST CONDITION		MEASUREMENT DETAIL	
CHANNEL	Channel 116	FREQUENCY RANGE	1 ~ 40GHz
INPUT POWER (SYSTEM)	120Vac, 60Hz	DETECTOR FUNCTION	Peak (PK) Average (AV)
ENVIRONMENTAL CONDITIONS	24deg. C, 67%RH	TESTED BY	Cedric Wu

ANTENNA POLARITY & TEST DISTANCE: HORIZONTAL AT 3 M								
NO.	FREQ. (MHz)	EMISSION LEVEL (dBuV/m)	LIMIT (dBuV/m)	MARGIN (dB)	ANTENNA HEIGHT (m)	TABLE ANGLE (Degree)	RAW VALUE (dBuV)	CORRECTION FACTOR (dB/m)
1	*5580.00	102.2 PK			1.09 H	85	63.00	39.20
2	*5580.00	90.3 AV			1.09 H	85	51.10	39.20
3	11160.00	59.0 PK	74.0	-15.0	1.05 H	342	7.70	51.30
4	11160.00	45.6 AV	54.0	-8.4	1.05 H	342	-5.70	51.30
ANTENNA POLARITY & TEST DISTANCE: VERTICAL AT 3 M								
NO.	FREQ. (MHz)	EMISSION LEVEL (dBuV/m)	LIMIT (dBuV/m)	MARGIN (dB)	ANTENNA HEIGHT (m)	TABLE ANGLE (Degree)	RAW VALUE (dBuV)	CORRECTION FACTOR (dB/m)
1	*5580.00	96.3 PK			1.00 V	108	57.10	39.20
2	*5580.00	84.4 AV			1.00 V	108	45.20	39.20
3	11160.00	58.5 PK	74.0	-15.5	1.00 V	182	7.20	51.30
4	11160.00	45.0 AV	54.0	-9.0	1.00 V	182	-6.30	51.30

REMARKS:

1. Emission level (dBuV/m) = Raw Value (dBuV) + Correction Factor (dB/m).
2. Correction Factor (dB/m) = Antenna Factor (dB/m) + Cable Factor (dB).
3. The other emission levels were very low against the limit.
4. Margin value = Emission level – Limit value.
5. " * ": Fundamental frequency.



A D T

EUT TEST CONDITION		MEASUREMENT DETAIL	
CHANNEL	Channel 140	FREQUENCY RANGE	1 ~ 40GHz
INPUT POWER (SYSTEM)	120Vac, 60Hz	DETECTOR FUNCTION	Peak (PK) Average (AV)
ENVIRONMENTAL CONDITIONS	24deg. C, 67%RH	TESTED BY	Cedric Wu

ANTENNA POLARITY & TEST DISTANCE: HORIZONTAL AT 3 M								
NO.	FREQ. (MHz)	EMISSION LEVEL (dBuV/m)	LIMIT (dBuV/m)	MARGIN (dB)	ANTENNA HEIGHT (m)	TABLE ANGLE (Degree)	RAW VALUE (dBuV)	CORRECTION FACTOR (dB/m)
1	*5700.00	100.5 PK			1.16 H	86	61.00	39.50
2	*5700.00	88.6 AV			1.16 H	86	49.10	39.50
3	#5725.00	54.2 PK	74.0	-19.8	1.14 H	89	14.70	39.50
4	#5725.00	42.7 AV	54.0	-11.3	1.14 H	89	3.20	39.50
5	11400.00	58.6 PK	74.0	-15.4	1.00 H	341	7.00	51.60
6	11400.00	45.1 AV	54.0	-8.9	1.00 H	341	-6.50	51.60
ANTENNA POLARITY & TEST DISTANCE: VERTICAL AT 3 M								
NO.	FREQ. (MHz)	EMISSION LEVEL (dBuV/m)	LIMIT (dBuV/m)	MARGIN (dB)	ANTENNA HEIGHT (m)	TABLE ANGLE (Degree)	RAW VALUE (dBuV)	CORRECTION FACTOR (dB/m)
1	*5700.00	94.9 PK			1.00 V	96	55.40	39.50
2	*5700.00	83.0 AV			1.00 V	96	43.50	39.50
3	#5725.00	53.9 PK	74.0	-20.1	1.00 V	99	14.40	39.50
4	#5725.00	42.5 AV	54.0	-11.5	1.00 V	99	3.00	39.50
5	11400.00	57.9 PK	74.0	-16.1	1.00 V	177	6.30	51.60
6	11400.00	44.7 AV	54.0	-9.3	1.00 V	177	-6.90	51.60

REMARKS:

1. Emission level (dBuV/m) = Raw Value (dBuV) + Correction Factor (dB/m).
2. Correction Factor (dB/m) = Antenna Factor (dB/m) + Cable Factor (dB).
3. The other emission levels were very low against the limit.
4. Margin value = Emission level – Limit value.
5. " * " : Fundamental frequency.
6. " # " : The radiated frequency is out of the restricted band.

BELOW 1GHz WORST-CASE DATA : 802.11a

EUT TEST CONDITION		MEASUREMENT DETAIL	
CHANNEL	Channel 36	FREQUENCY RANGE	Below 1000MHz
INPUT POWER (SYSTEM)	120Vac, 60Hz	DETECTOR FUNCTION	Quasi-Peak
ENVIRONMENTAL CONDITIONS	24deg. C, 67%RH	TESTED BY	Cedric Wu

ANTENNA POLARITY & TEST DISTANCE: HORIZONTAL AT 3 M								
NO.	FREQ. (MHz)	EMISSION LEVEL (dBuV/m)	LIMIT (dBuV/m)	MARGIN (dB)	ANTENNA HEIGHT (m)	TABLE ANGLE (Degree)	RAW VALUE (dBuV)	CORRECTION FACTOR (dB/m)
1	144.38	26.7 QP	43.5	-16.8	1.74 H	90	13.00	13.70
2	179.31	33.2 QP	43.5	-10.3	1.50 H	113	20.70	12.50
3	295.73	34.5 QP	46.0	-11.5	1.00 H	0	20.10	14.40
4	336.48	31.1 QP	46.0	-14.9	1.00 H	103	15.60	15.50
5	482.01	29.0 QP	46.0	-17.0	1.74 H	5	10.00	19.00
6	716.80	32.6 QP	46.0	-13.4	1.00 H	130	9.50	23.10

ANTENNA POLARITY & TEST DISTANCE: VERTICAL AT 3 M								
NO.	FREQ. (MHz)	EMISSION LEVEL (dBuV/m)	LIMIT (dBuV/m)	MARGIN (dB)	ANTENNA HEIGHT (m)	TABLE ANGLE (Degree)	RAW VALUE (dBuV)	CORRECTION FACTOR (dB/m)
1	99.75	25.7 QP	43.5	-17.8	1.00 V	79	16.50	9.20
2	336.48	28.4 QP	46.0	-17.6	1.49 V	43	12.90	15.50
3	431.56	30.2 QP	46.0	-15.8	1.00 V	352	12.40	17.80
4	575.15	27.4 QP	46.0	-18.6	1.49 V	5	6.40	21.00
5	724.56	26.7 QP	46.0	-19.3	1.49 V	252	3.40	23.30
6	837.11	28.9 QP	46.0	-17.1	1.49 V	5	3.80	25.10

REMARKS:

1. Emission level (dBuV/m) = Raw Value (dBuV) + Correction Factor (dB/m).
2. Correction Factor (dB/m) = Antenna Factor (dB/m) + Cable Factor (dB).
3. The other emission levels were very low against the limit.
4. Margin value = Emission level – Limit value.



EUT TEST CONDITION		MEASUREMENT DETAIL	
CHANNEL	Channel 100	FREQUENCY RANGE	Below 1000MHz
INPUT POWER (SYSTEM)	120Vac, 60Hz	DETECTOR FUNCTION	Quasi-Peak
ENVIRONMENTAL CONDITIONS	24deg. C, 67%RH	TESTED BY	Cedric Wu

ANTENNA POLARITY & TEST DISTANCE: HORIZONTAL AT 3 M								
NO.	FREQ. (MHz)	EMISSION LEVEL (dBuV/m)	LIMIT (dBuV/m)	MARGIN (dB)	ANTENNA HEIGHT (m)	TABLE ANGLE (Degree)	RAW VALUE (dBuV)	CORRECTION FACTOR (dB/m)
1	82.29	24.8 QP	40.0	-15.2	1.50 H	350	15.50	9.30
2	179.31	33.8 QP	43.5	-9.7	1.00 H	81	21.30	12.50
3	299.62	35.7 QP	46.0	-10.3	1.75 H	102	21.10	14.60
4	431.56	28.4 QP	46.0	-17.6	1.00 H	331	10.60	17.80
5	664.41	31.6 QP	46.0	-14.4	1.24 H	347	9.20	22.40
6	839.05	29.7 QP	46.0	-16.3	1.24 H	63	4.60	25.10
ANTENNA POLARITY & TEST DISTANCE: VERTICAL AT 3 M								
NO.	FREQ. (MHz)	EMISSION LEVEL (dBuV/m)	LIMIT (dBuV/m)	MARGIN (dB)	ANTENNA HEIGHT (m)	TABLE ANGLE (Degree)	RAW VALUE (dBuV)	CORRECTION FACTOR (dB/m)
1	80.35	23.3 QP	40.0	-16.7	1.50 V	302	13.80	9.50
2	233.64	25.0 QP	46.0	-21.0	1.00 V	126	12.90	12.10
3	336.48	28.7 QP	46.0	-17.3	1.25 V	55	13.20	15.50
4	431.56	30.5 QP	46.0	-15.5	1.00 V	39	12.70	17.80
5	528.58	24.6 QP	46.0	-21.4	1.75 V	28	4.50	20.10
6	722.62	26.2 QP	46.0	-19.8	1.25 V	63	3.00	23.20

REMARKS:

1. Emission level (dBuV/m) = Raw Value (dBuV) + Correction Factor (dB/m).
2. Correction Factor (dB/m) = Antenna Factor (dB/m) + Cable Factor (dB).
3. The other emission levels were very low against the limit.
4. Margin value = Emission level – Limit value.

4.2 CONDUCTED EMISSION MEASUREMENT

4.2.1 LIMITS OF CONDUCTED EMISSION MEASUREMENT

FREQUENCY OF EMISSION (MHz)	CONDUCTED LIMIT (dB μ V)	
	Quasi-peak	Average
0.15 ~ 0.5	66 to 56	56 to 46
0.5 ~ 5	56	46
5 ~ 30	60	50

- NOTE:**
1. The lower limit shall apply at the transition frequencies.
 2. The limit decreases in line with the logarithm of the frequency in the range of 0.15 to 0.50MHz.
 3. All emanations from a class A/B digital device or system, including any network of conductors and apparatus connected thereto, shall not exceed the level of field strengths specified above.

4.2.2 TEST INSTRUMENTS

DESCRIPTION & MANUFACTURER	MODEL NO.	SERIAL NO.	DATE OF CALIBRATION	DUE DATE OF CALIBRATION
Test Receiver ROHDE & SCHWARZ	ESCS30	100289	Nov. 16, 2012	Nov. 15, 2013
RF signal cable Woken	5D-FB	Cable-HYC01-01	Dec. 28, 2012	Dec. 27, 2013
LISN ROHDE & SCHWARZ (Peripheral)	ESH3-Z5	100312	Jul. 02, 2012	Jul. 01, 2013
LISN ROHDE & SCHWARZ (EUT)	ESH3-Z5	835239/001	Feb. 07, 2012	Feb. 06, 2013
Software ADT	BV ADT_Cond_ V7.3.7.3	NA	NA	NA

- NOTE:**
1. The calibration interval of the above test instruments is 12 months and the calibrations are traceable to NML/ROC and NIST/USA.
 2. The test was performed in HwaYa Shielded Room 1.
 3. The VCCI Site Registration No. is C-2040.

4.2.3 TEST PROCEDURES

- The EUT was placed 0.4 meters from the conducting wall of the shielded room with EUT being connected to the power mains through a line impedance stabilization network (LISN). Other support units were connected to the power mains through another LISN. The two LISNs provide 50 ohm/ 50uH of coupling impedance for the measuring instrument.
- Both lines of the power mains connected to the EUT were checked for maximum conducted interference.
- The frequency range from 150kHz to 30MHz was searched. Emission levels under (Limit - 20dB) was not recorded.

NOTE: All modes of operation were investigated and the worst-case emissions are reported.

4.2.4 DEVIATION FROM TEST STANDARD

No deviation.

4.2.5 TEST SETUP

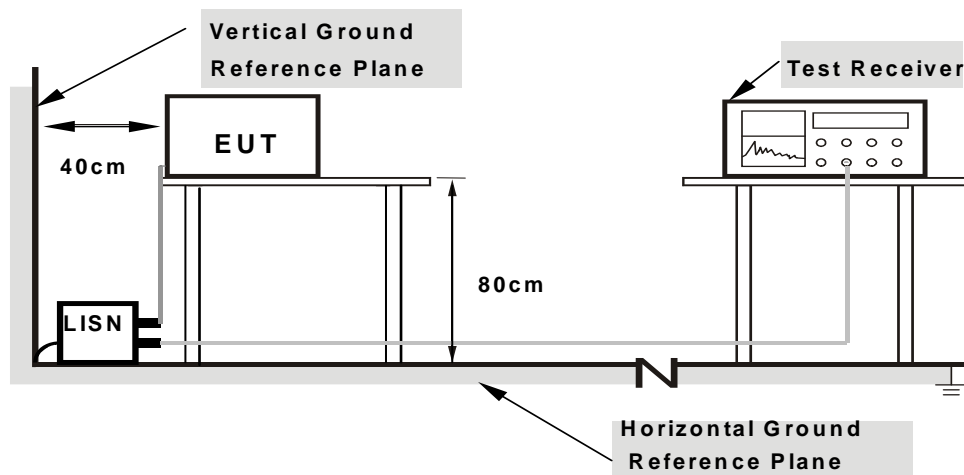

- Note:**
- Support units were connected to second LISN.
 - Both of LISNs (AMN) are 80 cm from EUT and at least 80 from other units and other metal planes

For the actual test configuration, please refer to the attached file (Test Setup Photo).

4.2.6 EUT OPERATING CONDITIONS

Same as 4.1.6.

4.2.7 TEST RESULTS

CONDUCTED WORST-CASE DATA : 802.11a

PHASE	Line 1	6dB BANDWIDTH	9kHz
CHANNEL	Channel 36		

No	Freq. [MHz]	Corr. Factor (dB)	Reading Value		Emission Level		Limit		Margin	
			[dB (uV)]		[dB (uV)]		[dB (uV)]		(dB)	
			Q.P.	AV.	Q.P.	AV.	Q.P.	AV.	Q.P.	AV.
1	0.19717	0.08	48.61	35.02	48.69	35.10	63.73	53.73	-15.04	-18.63
2	0.40415	0.08	39.29	19.94	39.37	20.02	57.77	47.77	-18.40	-27.75
3	0.50507	0.09	38.02	18.63	38.11	18.72	56.00	46.00	-17.89	-27.28
4	0.80945	0.11	31.03	10.22	31.14	10.33	56.00	46.00	-24.86	-35.67
5	3.35229	0.16	39.59	23.05	39.75	23.21	56.00	46.00	-16.25	-22.79
6	25.99901	0.39	27.38	22.29	27.77	22.68	60.00	50.00	-32.23	-27.32

- REMARKS:**
1. Q.P. and AV. are abbreviations of quasi-peak and average individually.
 2. The emission levels of other frequencies were very low against the limit.
 3. Margin value = Emission level - Limit value
 4. Correction factor = Insertion loss + Cable loss
 5. Emission Level = Correction Factor + Reading Value.

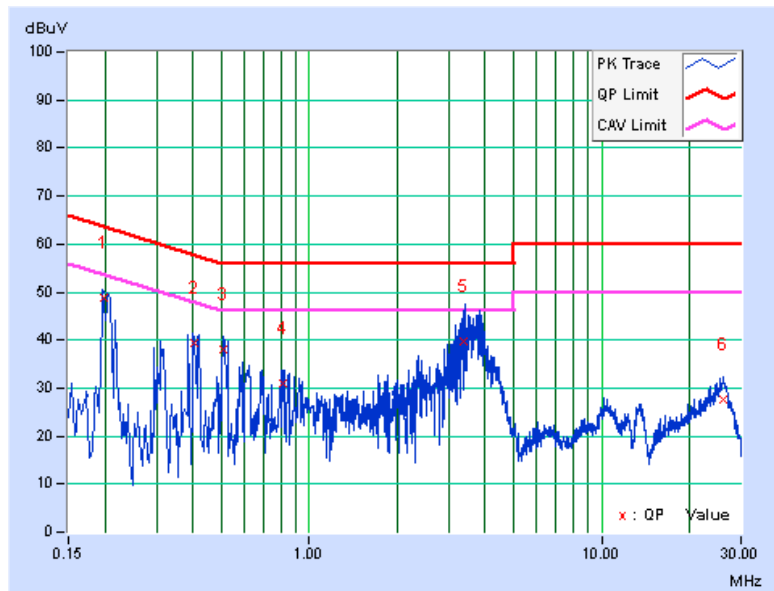



A D T

PHASE	Line 2	6dB BANDWIDTH	9kHz
CHANNEL	Channel 36		

No	Freq. [MHz]	Corr. Factor (dB)	Reading Value		Emission Level		Limit		Margin	
			[dB (uV)]		[dB (uV)]		[dB (uV)]		(dB)	
			Q.P.	AV.	Q.P.	AV.	Q.P.	AV.	Q.P.	AV.
1	0.21059	0.08	46.65	30.66	46.73	30.74	63.18	53.18	-16.45	-22.44
2	0.39219	0.07	38.64	19.78	38.71	19.85	58.02	48.02	-19.31	-28.17
3	0.49324	0.08	36.44	18.01	36.52	18.09	56.11	46.11	-19.59	-28.02
4	0.82887	0.12	30.43	10.82	30.55	10.94	56.00	46.00	-25.45	-35.06
5	3.72765	0.20	39.16	24.34	39.36	24.54	56.00	46.00	-16.64	-21.46
6	6.02780	0.25	21.02	15.10	21.27	15.35	60.00	50.00	-38.73	-34.65

- REMARKS:**
1. Q.P. and AV. are abbreviations of quasi-peak and average individually.
 2. The emission levels of other frequencies were very low against the limit.
 3. Margin value = Emission level - Limit value
 4. Correction factor = Insertion loss + Cable loss
 5. Emission Level = Correction Value + Reading Value.

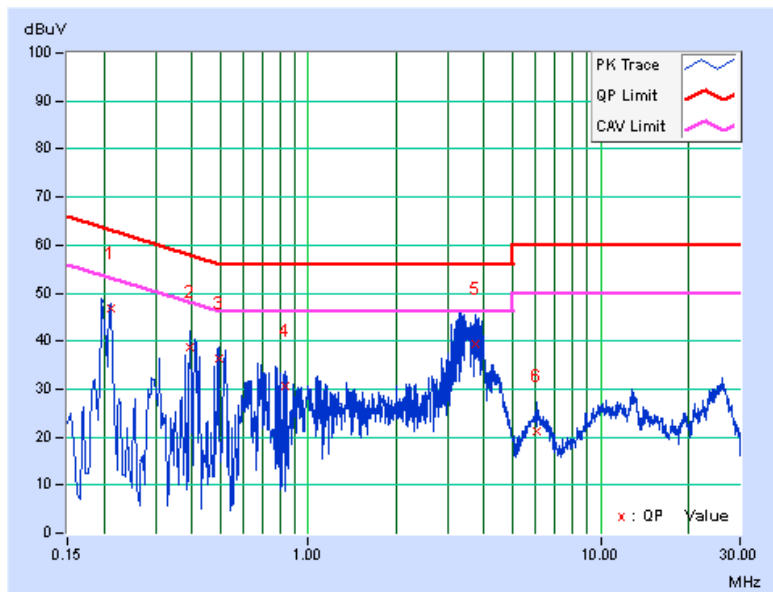



A D T

PHASE	Line 1	6dB BANDWIDTH	9kHz
CHANNEL	Channel 100		

No	Freq. [MHz]	Corr. Factor (dB)	Reading Value		Emission Level		Limit		Margin	
			[dB (uV)]		[dB (uV)]		[dB (uV)]		(dB)	
			Q.P.	AV.	Q.P.	AV.	Q.P.	AV.	Q.P.	AV.
1	0.19255	0.07	48.60	31.82	48.67	31.89	63.93	53.93	-15.25	-22.03
2	0.40806	0.08	39.03	20.43	39.11	20.51	57.69	47.69	-18.58	-27.18
3	0.48678	0.09	38.74	20.46	38.83	20.55	56.22	46.22	-17.40	-25.68
4	0.90895	0.11	29.17	10.15	29.28	10.26	56.00	46.00	-26.72	-35.74
5	3.61817	0.17	37.46	24.21	37.63	24.38	56.00	46.00	-18.37	-21.62
6	10.39811	0.27	22.32	16.99	22.59	17.26	60.00	50.00	-37.41	-32.74

- REMARKS:**
1. Q.P. and AV. are abbreviations of quasi-peak and average individually.
 2. The emission levels of other frequencies were very low against the limit.
 3. Margin value = Emission level - Limit value
 4. Correction factor = Insertion loss + Cable loss
 5. Emission Level = Correction Factor + Reading Value.

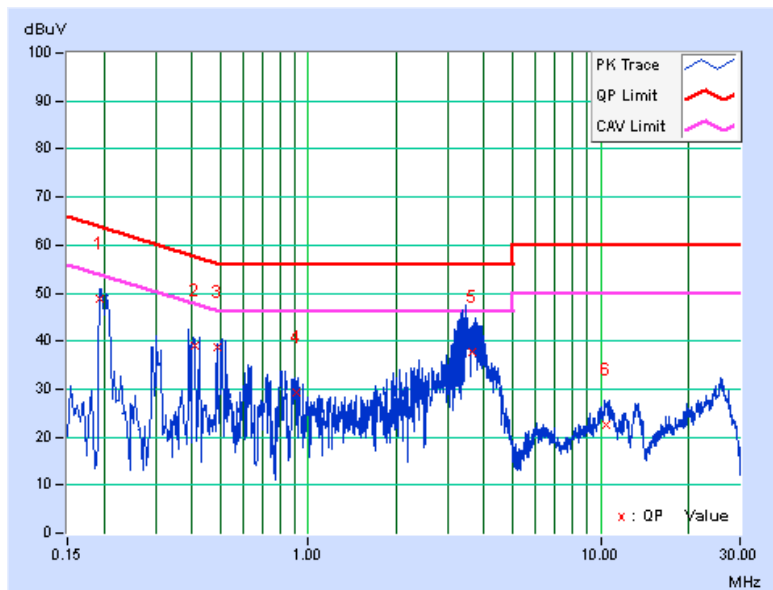



A D T

PHASE	Line 2	6dB BANDWIDTH	9kHz
CHANNEL	Channel 100		

No	Freq. [MHz]	Corr. Factor (dB)	Reading Value		Emission Level		Limit		Margin	
			[dB (uV)]		[dB (uV)]		[dB (uV)]		(dB)	
			Q.P.	AV.	Q.P.	AV.	Q.P.	AV.	Q.P.	AV.
1	0.20783	0.08	47.07	33.14	47.15	33.22	63.29	53.29	-16.14	-20.07
2	0.40415	0.07	38.62	19.25	38.69	19.32	57.77	47.77	-19.08	-28.45
3	0.80945	0.12	30.81	10.60	30.93	10.72	56.00	46.00	-25.07	-35.28
4	3.44222	0.18	39.32	25.12	39.50	25.30	56.00	46.00	-16.50	-20.70
5	12.90825	0.35	23.50	18.21	23.85	18.56	60.00	50.00	-36.15	-31.44
6	26.34700	0.42	26.69	21.59	27.11	22.01	60.00	50.00	-32.89	-27.99

- REMARKS:**
1. Q.P. and AV. are abbreviations of quasi-peak and average individually.
 2. The emission levels of other frequencies were very low against the limit.
 3. Margin value = Emission level - Limit value
 4. Correction factor = Insertion loss + Cable loss
 5. Emission Level = Correction Value + Reading Value.

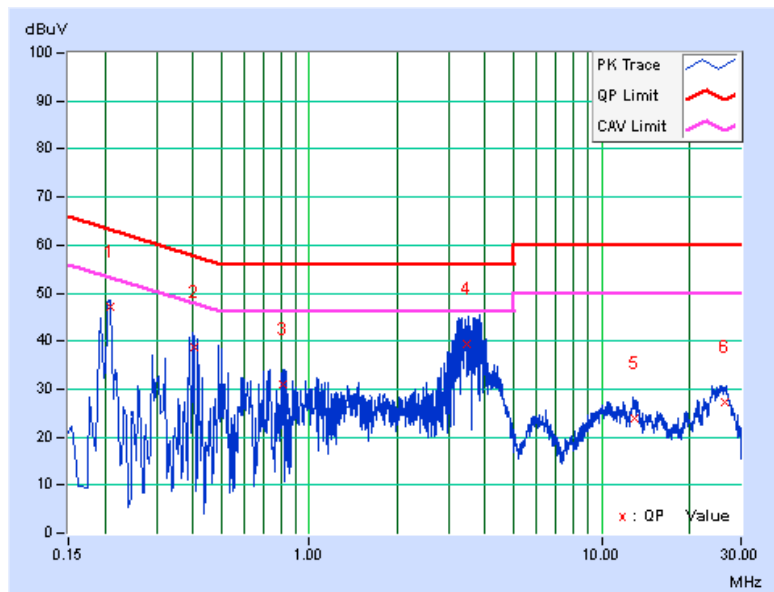

4.3 PEAK TRANSMIT POWER MEASUREMENT

4.3.1 LIMITS OF PEAK TRANSMIT POWER MEASUREMENT

FREQUENCY BAND	LIMIT
5.150 ~ 5.250GHz	The lesser of 50mW (17dBm) or 4dBm + 10logB
5.250 ~ 5.350GHz	The lesser of 250mW (24dBm) or 11dBm + 10logB
5.470 ~ 5.725GHz	The lesser of 250mW (24dBm) or 11dBm + 10logB

NOTE: Where B is the 26dB emission bandwidth in MHz.

Per KDB 662911 D01 Multiple Transmitter Output v01r02 Method of conducted output power measurement on IEEE 802.11 devices,

Array Gain = 0 dB (i.e., no array gain) for NANT ≤ 4;

Array Gain = 0 dB (i.e., no array gain) for channel widths ≥ 40 MHz for any NANT;

Array Gain = 5 log(NANT/NSS) dB or 3 dB, whichever is less for 20-MHz channel widths with NANT ≥ 5.

For power measurements on all other devices: Array Gain = 10 log(NANT/NSS) dB.

4.3.2 TEST SETUP

FOR POWER OUTPUT MEASUREMENT

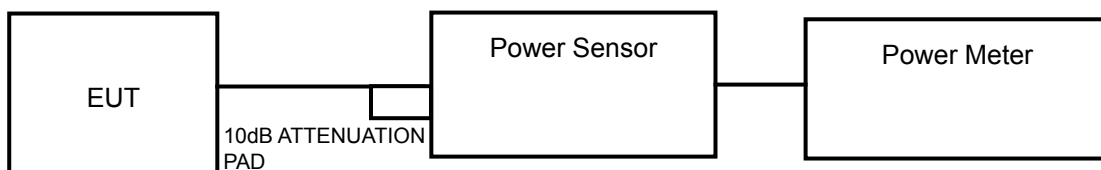

FOR 26dB BANDWIDTH

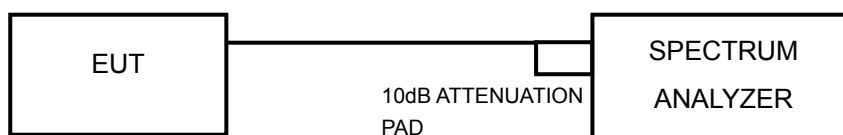

4.3.3 TEST INSTRUMENTS

Refer to section 4.1.3 to get information of above instrument.

4.3.4 TEST PROCEDURE

FOR AVERAGE POWER MEASUREMENT

Duty cycle of test signal is < 98 %. Method PM is used to perform output power measurement, trigger and gating function of wide band power meter is enabled to measure max output power of TX on burst. Duty factor is not added to measured value.

FOR 26dB BANDWIDTH

- 1) Set RBW = approximately 1% of the emission bandwidth.
- 2) Set the VBW > RBW.
- 3) Detector = Peak.
- 4) Trace mode = max hold.
- 5) Measure the maximum width of the emission that is 26 dB down from the peak of the emission. Compare this with the RBW setting of the analyzer. Readjust RBW and repeat measurement as needed until the RBW/EBW ratio is approximately 1%.

4.3.5 DEVIATION FROM TEST STANDARD

No deviation.

4.3.6 EUT OPERATING CONDITIONS

The software provided by client to enable the EUT under transmission condition continuously at specific channel frequencies individually.



4.3.7 TEST RESULTS

POWER OUTPUT: 802.11a

CHANNEL	CHANNEL FREQUENCY (MHz)	AVERAGE POWER (mW)	AVERAGE POWER (dBm)	POWER LIMIT (dBm)	PASS/FAIL
36	5180	13.335	11.25	17	PASS
40	5200	12.942	11.12	17	PASS
48	5240	12.359	10.92	17	PASS
52	5260	12.445	10.95	24	PASS
60	5300	11.561	10.63	24	PASS
64	5320	11.776	10.71	24	PASS
100	5500	14.060	11.48	24	PASS
116	5580	13.490	11.30	24	PASS
140	5700	13.677	11.36	24	PASS

802.11n (20MHz)

CHANNEL	CHANNEL FREQUENCY (MHz)	AVERAGE POWER (mW)	AVERAGE POWER (dBm)	POWER LIMIT (dBm)	PASS/FAIL
36	5180	10.593	10.25	17	PASS
40	5200	10.046	10.02	17	PASS
48	5240	9.638	9.84	17	PASS
52	5260	9.572	9.81	24	PASS
60	5300	9.204	9.64	24	PASS
64	5320	9.638	9.84	24	PASS
100	5500	11.092	10.45	24	PASS
116	5580	10.839	10.35	24	PASS
140	5700	11.803	10.72	24	PASS



A D T

26dB BANDWIDTH: 802.11a

CHANNEL	CHANNEL FREQUENCY (MHz)	26dBc BANDWIDTH (MHz)	PASS / FAIL
36	5180	22.48	PASS
40	5200	23.13	PASS
48	5240	22.73	PASS
52	5260	22.81	PASS
60	5300	22.85	PASS
64	5320	22.38	PASS
100	5500	22.89	PASS
116	5580	22.65	PASS
140	5700	22.59	PASS

802.11n (20MHz)

CHANNEL	CHANNEL FREQUENCY (MHz)	26dBc BANDWIDTH (MHz)	PASS / FAIL
36	5180	23.50	PASS
40	5200	23.59	PASS
48	5240	24.36	PASS
52	5260	23.26	PASS
60	5300	24.04	PASS
64	5320	24.65	PASS
100	5500	24.22	PASS
116	5580	23.59	PASS
140	5700	23.75	PASS

4.4 PEAK POWER SPECTRAL DENSITY MEASUREMENT

4.4.1 LIMITS OF PEAK POWER SPECTRAL DENSITY MEASUREMENT

FREQUENCY BAND	LIMIT
5.150 ~ 5.250GHz	4dBm
5.250 ~ 5.350GHz	11dBm
5.470 ~ 5.725GHz	11dBm

4.4.2 TEST SETUP



4.4.3 TEST INSTRUMENTS

Refer to section 4.1.3 to get information of above instrument.

4.4.4 TEST PROCEDURES

- 1) Set span to encompass the entire emission bandwidth (EBW) of the signal.
- 2) Set RBW = 30 KHz, Set VBW \geq 1 MHz, Detector = RMS
- 3) Set Channel power measure = 1MHz
- 4) Sweep time = auto, trigger set to “free run”.
- 5) Trace average at least 100 traces in power averaging mode.
- 6) Record the max value and add 10 log (1/duty cycle)

4.4.5 DEVIATION FROM TEST STANDARD

No deviation.

4.4.6 EUT OPERATING CONDITIONS

Same as 4.3.6.

4.4.7 TEST RESULTS

802.11a

CHANNEL	FREQUENCY (MHz)	PSD W/O DUTY FACTOR (dBm)	DUTY FACTOR	PSD WITH DUTY FACTOR (dBm)	MAXIMUM LIMIT (dBm)	PASS/FAIL
36	5180	-0.49	0.11	-0.38	4	PASS
40	5200	-0.33	0.11	-0.22	4	PASS
48	5240	-0.59	0.11	-0.48	4	PASS
52	5260	-0.28	0.11	-0.17	11	PASS
60	5300	-0.69	0.11	-0.58	11	PASS
64	5320	-0.71	0.11	-0.6	11	PASS
100	5500	-0.46	0.11	-0.35	11	PASS
116	5580	-0.33	0.11	-0.22	11	PASS
132	5660	-0.47	0.11	-0.36	11	PASS
140	5700	-0.14	0.11	-0.03	11	PASS

NOTE: Refer to section 3.3 for duty cycle spectrum plot.

802.11n (20MHz)

CHANNEL	FREQUENCY (MHz)	PSD W/O DUTY FACTOR (dBm)	DUTY FACTOR	PSD WITH DUTY FACTOR (dBm)	MAXIMUM LIMIT (dBm)	PASS/FAIL
36	5180	-1.39	0.11	-1.28	4	PASS
40	5200	-1.16	0.11	-1.05	4	PASS
48	5240	-1.39	0.11	-1.28	4	PASS
52	5260	-1.45	0.11	-1.34	11	PASS
60	5300	-1.84	0.11	-1.73	11	PASS
64	5320	-1.82	0.11	-1.71	11	PASS
100	5500	-1.52	0.11	-1.41	11	PASS
116	5580	-1.30	0.11	-1.19	11	PASS
132	5660	-1.43	0.11	-1.32	11	PASS
140	5700	-1.03	0.11	-0.92	11	PASS

NOTE: Refer to section 3.3 for duty cycle spectrum plot.

4.5 PEAK POWER EXCURSION MEASUREMENT

4.5.1 LIMITS OF PEAK POWER EXCURSION MEASUREMENT

Shall not exceed 13 dB.

4.5.2 TEST SETUP

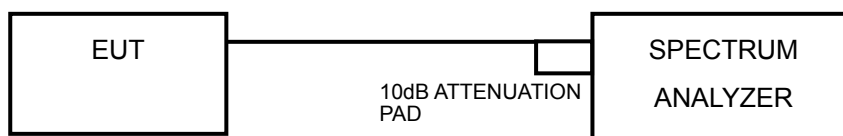

4.5.3 TEST INSTRUMENTS

Refer to section 4.1.3 to get information of above instrument.

4.5.4 TEST PROCEDURE

- 1) Set RBW = 1 MHz, VBW \geq 3 MHz, Detector = peak.
- 2) Trace mode = max-hold. Allow the sweeps to continue until the trace stabilizes.
- 3) Use the peak search function to find the peak of the spectrum.
- 4) Measure the PPSD.
- 5) Compute the ratio of the maximum of the peak-max-hold spectrum to the PPSD.

4.5.5 DEVIATION FROM TEST STANDARD

No deviation.

4.5.6 EUT OPERATING CONDITIONS

Same as 4.2.6

4.5.7 TEST RESULTS

802.11a

CHAN.	CHANNEL FREQUENCY (MHz)	PEAK VALUE (dBm)	PPSD WITHOUT DUTY FACTOR (dBm)	PPSD WITH DUTY FACTOR (dBm)	PEAK POWER EXCURSION (dB)	PEAK to AVERAGE EXCURSION LIMIT (dB)	PASS /FAIL
36	5180	7.49	-0.49	-0.38	7.87	13	PASS
40	5200	7.89	-0.33	-0.22	8.11	13	PASS
48	5240	7.67	-0.59	-0.48	8.15	13	PASS
52	5260	8.21	-0.28	-0.17	8.38	13	PASS
60	5300	7.92	-0.69	-0.58	8.50	13	PASS
64	5320	7.34	-0.71	-0.6	7.94	13	PASS
100	5500	8.07	-0.46	-0.35	8.42	13	PASS
116	5580	7.90	-0.33	-0.22	8.12	13	PASS
132	5660	7.74	-0.47	-0.36	8.10	13	PASS
140	5700	7.91	-0.14	-0.03	7.94	13	PASS

NOTE: Refer to section 3.3 for duty cycle spectrum plot.

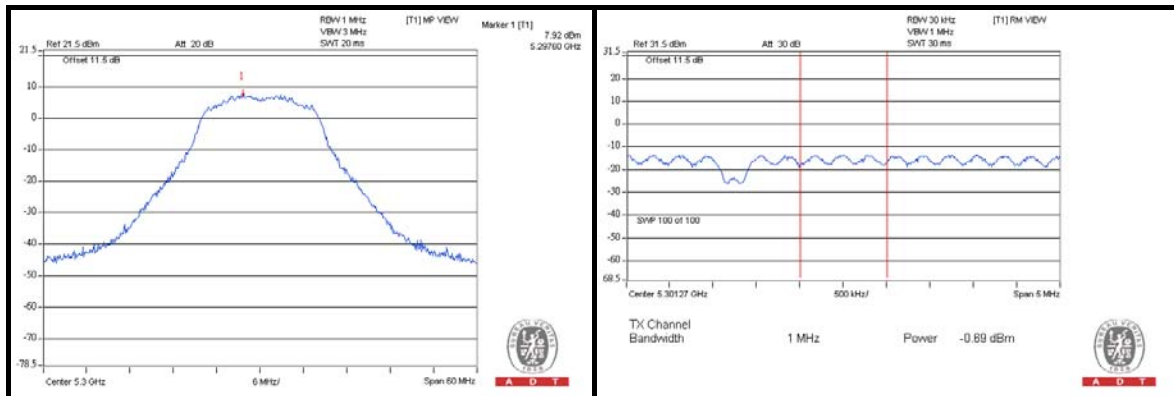

802.11n (20MHz)

CHAN.	CHANNEL FREQUENCY (MHz)	PEAK VALUE (dBm)	PPSD WITHOUT DUTY FACTOR (dBm)	PPSD WITH DUTY FACTOR (dBm)	PEAK POWER EXCURSION (dB)	PEAK to AVERAGE EXCURSION LIMIT (dB)	PASS /FAIL
36	5180	6.93	-1.39	-1.28	8.21	13	PASS
40	5200	6.77	-1.16	-1.05	7.82	13	PASS
48	5240	6.48	-1.39	-1.28	7.76	13	PASS
52	5260	6.86	-1.45	-1.34	8.20	13	PASS
60	5300	6.76	-1.84	-1.73	8.49	13	PASS
64	5320	6.41	-1.82	-1.71	8.12	13	PASS
100	5500	6.99	-1.52	-1.41	8.40	13	PASS
116	5580	7.16	-1.30	-1.19	8.35	13	PASS
132	5660	6.42	-1.43	-1.32	7.74	13	PASS
140	5700	7.34	-1.03	-0.92	8.26	13	PASS

NOTE: Refer to section 3.3 for duty cycle spectrum plot.

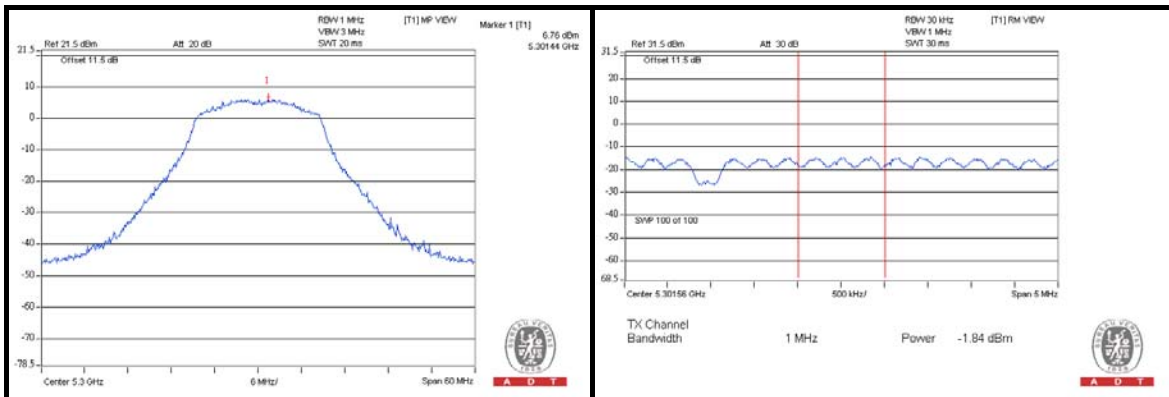

4.6 FREQUENCY STABILITY

4.6.1 LIMITS OF FREQUENCY STABILITY MEASUREMENT

The frequency of the carrier signal shall be maintained within band of operation

4.6.2 TEST SETUP

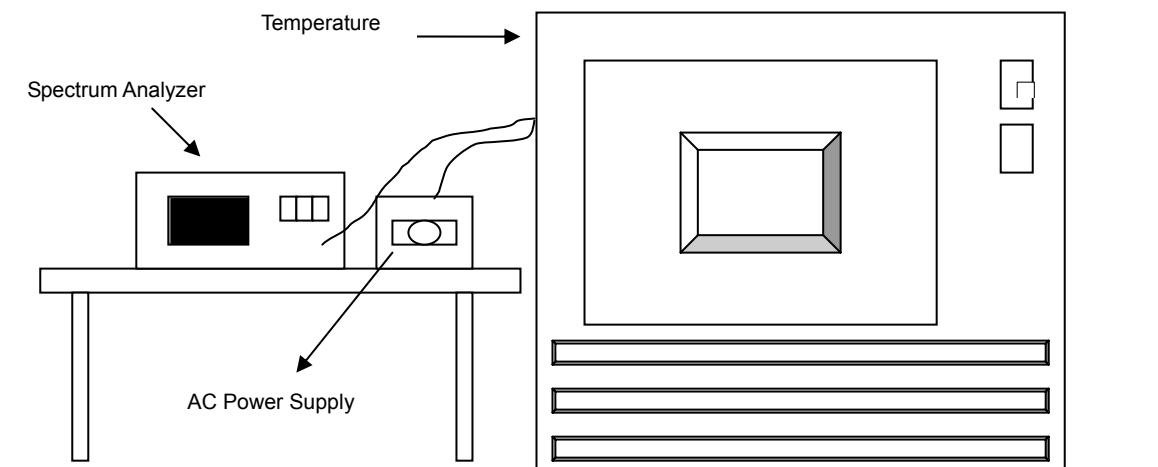

4.6.3 TEST INSTRUMENTS

Refer to section 4.1.3 to get information of above instrument.

4.6.4 TEST PROCEDURE

- a. The EUT was placed inside the environmental test chamber and powered by nominal AC voltage.
- b. Turn the EUT on and couple its output to a spectrum analyzer.
- c. Turn the EUT off and set the chamber to the highest temperature specified.
- d. Allow sufficient time (approximately 30 min) for the temperature of the chamber to stabilize, turn the EUT on and measure the operating frequency after 2, 5, and 10 minutes.
- e. Repeat step 2 and 3 with the temperature chamber set to the lowest temperature.
- f. The test chamber was allowed to stabilize at +20 degree C for a minimum of 30 minutes. The supply voltage was then adjusted on the EUT from 85% to 115% and the frequency record.

4.6.5 DEVIATION FROM TEST STANDARD

No deviation.

4.6.6 EUT OPERATING CONDITION

Set the EUT transmit at un-modulation mode to test frequency stability.

4.6.7 TEST RESULTS

FREQUENCY STABILITY VERSUS TEMP.									
OPERATING FREQUENCY: 5320MHz									
TEMP. (°C)	POWER SUPPLY (Vac)	0 MINUTE		2 MINUTE		5 MINUTE		10 MINUTE	
		Measured Frequency (MHz)	Frequency Drift (ppm)	Measured Frequency (MHz)	Frequency Drift (ppm)	Measured Frequency (MHz)	Frequency Drift (ppm)	Measured Frequency (MHz)	Frequency Drift (ppm)
60	120	5320.0118	2.2180	5320.008	1.5038	5320.0109	2.0489	5319.999	-0.1880
50	120	5319.9989	-0.2068	5320.0094	1.7669	5320.0076	1.4286	5319.9996	-0.0752
40	120	5319.9977	-0.4323	5319.9972	-0.5263	5319.9962	-0.7143	5319.9959	-0.7707
30	120	5319.9848	-2.8571	5319.9946	-1.0150	5319.9914	-1.6165	5319.9888	-2.1053
20	120	5320.0221	4.1541	5320.0212	3.9850	5320.0247	4.6429	5320.0193	3.6278
10	120	5319.9915	-1.5977	5319.9861	-2.6128	5319.9856	-2.7068	5319.9915	-1.5977
0	120	5320.0221	4.1541	5320.0215	4.0414	5320.0248	4.6617	5320.0214	4.0226
-10	120	5320.0284	5.3383	5320.0295	5.5451	5320.0255	4.7932	5320.025	4.6992
-20	120	5320.0097	1.8233	5320.0195	3.6654	5320.0169	3.1767	5320.0172	3.2331
-30	120	5320.0048	0.9023	5319.9978	-0.4135	5320.0007	0.1316	5320.0023	0.4323

FREQUENCY STABILITY VERSUS VOLTAGE									
OPERATING FREQUENCY: 5320MHz									
TEMP. (°C)	POWER SUPPLY (Vac)	0 MINUTE		2 MINUTE		5 MINUTE		10 MINUTE	
		Measured Frequency (MHz)	Frequency Drift (ppm)	Measured Frequency (MHz)	Frequency Drift (ppm)	Measured Frequency (MHz)	Frequency Drift (ppm)	Measured Frequency (MHz)	Frequency Drift (ppm)
20	138	5320.0223	4.1917	5320.0213	4.0038	5320.0233	4.3797	5320.0192	3.6090
	120	5320.0221	4.1541	5320.0212	3.9850	5320.0247	4.6429	5320.0193	3.6278
	102	5320.0212	3.9850	5320.0221	4.1541	5320.0248	4.6617	5320.0181	3.4023

5. PHOTOGRAPHS OF THE TEST CONFIGURATION

Please refer to the attached file (Test Setup Photo).



6. INFORMATION ON THE TESTING LABORATORIES

We, Bureau Veritas Consumer Products Services (H.K.) Ltd., Taoyuan Branch, were founded in 1988 to provide our best service in EMC, Radio, Telecom and Safety consultation. Our laboratories are accredited and approved according to ISO/IEC 17025.

If you have any comments, please feel free to contact us at the following:

Linko EMC/RF Lab:

Tel: 886-2-26052180

Fax: 886-2-26051924

Hsin Chu EMC/RF Lab:

Tel: 886-3-5935343

Fax: 886-3-5935342

Hwa Ya EMC/RF/Safety Telecom Lab:

Tel: 886-3-3183232

Fax: 886-3-3270892

Email: service.adt@tw.bureauveritas.com

Web Site: www.bureauveritas-adt.com

The address and road map of all our labs can be found in our web site also.

7. APPENDIX A – MODIFICATIONS RECORDERS FOR ENGINEERING CHANGES TO THE EUT BY THE LAB

No modifications were made to the EUT by the lab during the test.

---END---