

- NOTES:
- UNLESS OTHERWISE SPECIFIED, ALL FORM CONTOURS $\triangle 2.5 \text{ A B C}$ FOR UNDIMENSIONED PART DEFINITION SEE ASSOCIATED DATABANKED ELECTRONIC DATA.
 - COMMON SPECIFICATION: USE AGILE PARTS LIST FOR LATEST REVISION OF COMMON SPECIFICATION DRAWING.
 - PRODUCT SPECIFICATION: USE AGILE PARTS LIST FOR LATEST REVISION OF PRODUCT SPECIFICATION DRAWING.
 - SEE DETAIL PART PRINTS FOR MATERIAL CALL OUTS
 - RESTRICTED AND REPORTABLE SUBSTANCES FOR PARTS PER GMW3059 AND PANASONIC F26000.
 - APPLY SILICON GREASE KS-609 ON CONTACT SURFACE OF IC AMPLIFIER AND HEAT SINK. SEE FACTORY WORK INSTRUCTIONS FOR DETAILS.

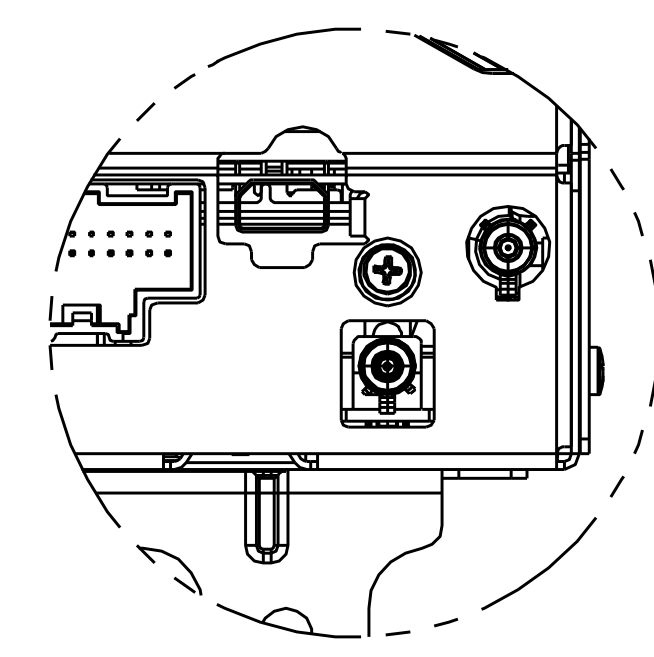

DETAIL C
CDT+XM
REAR VIEW

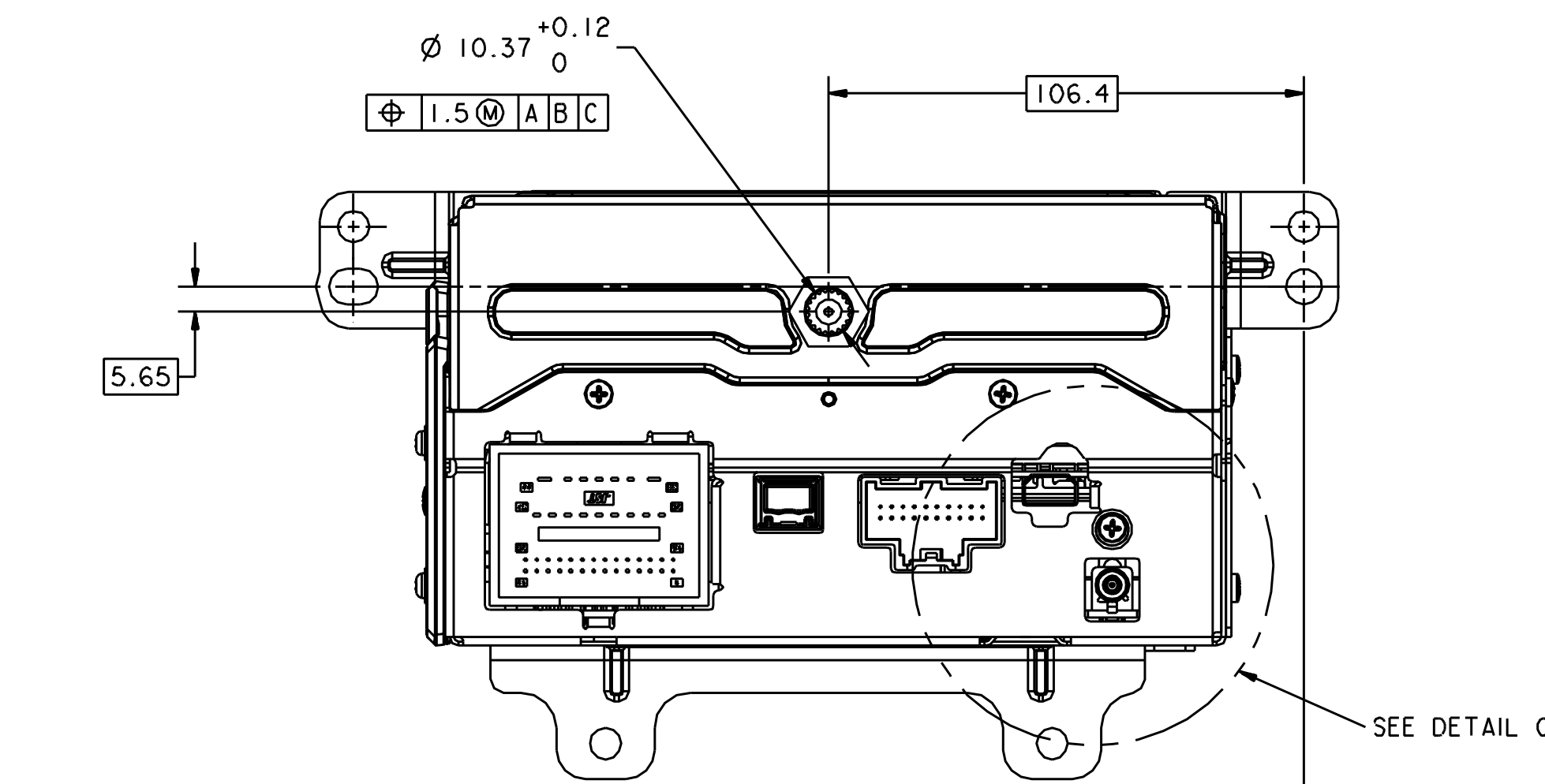
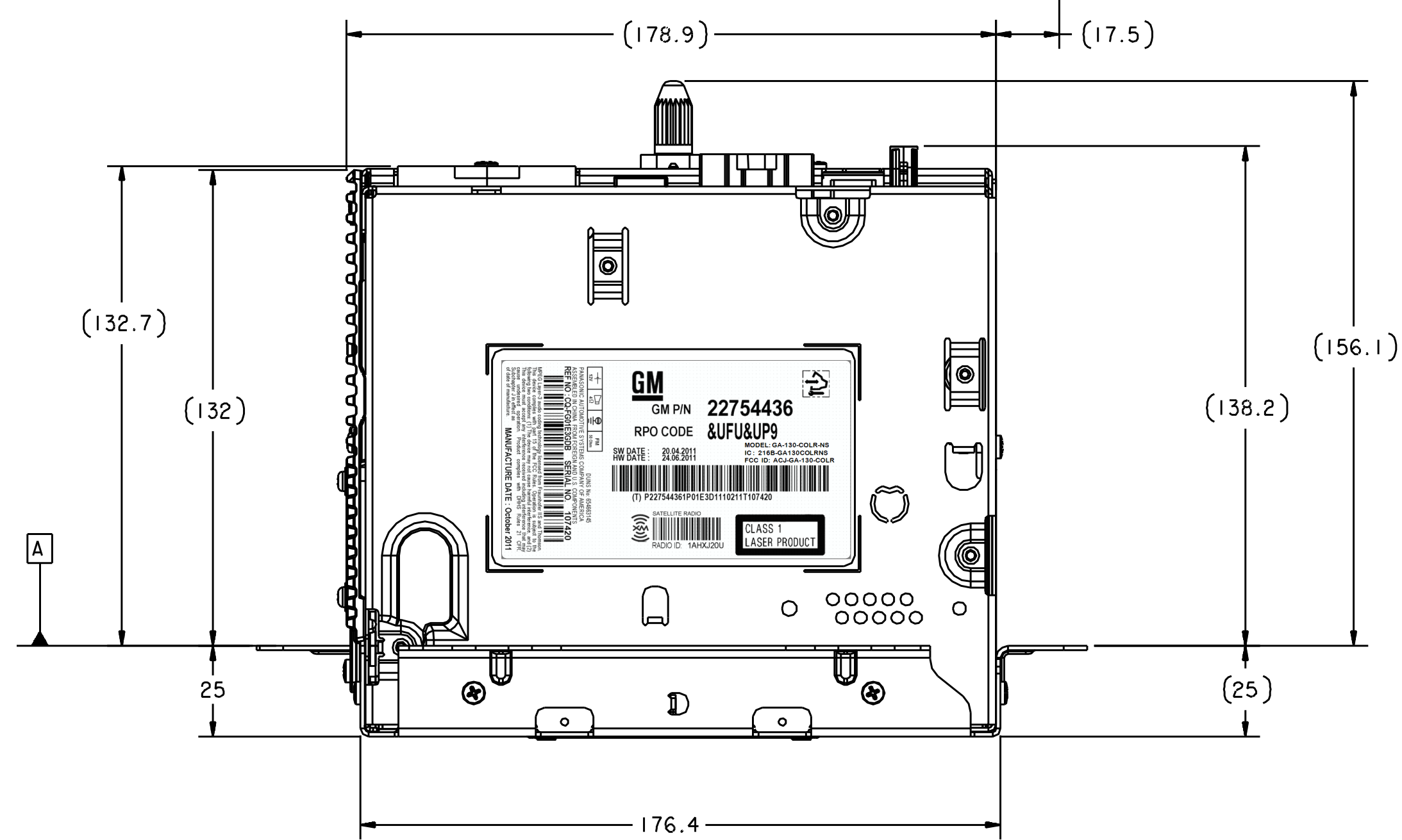
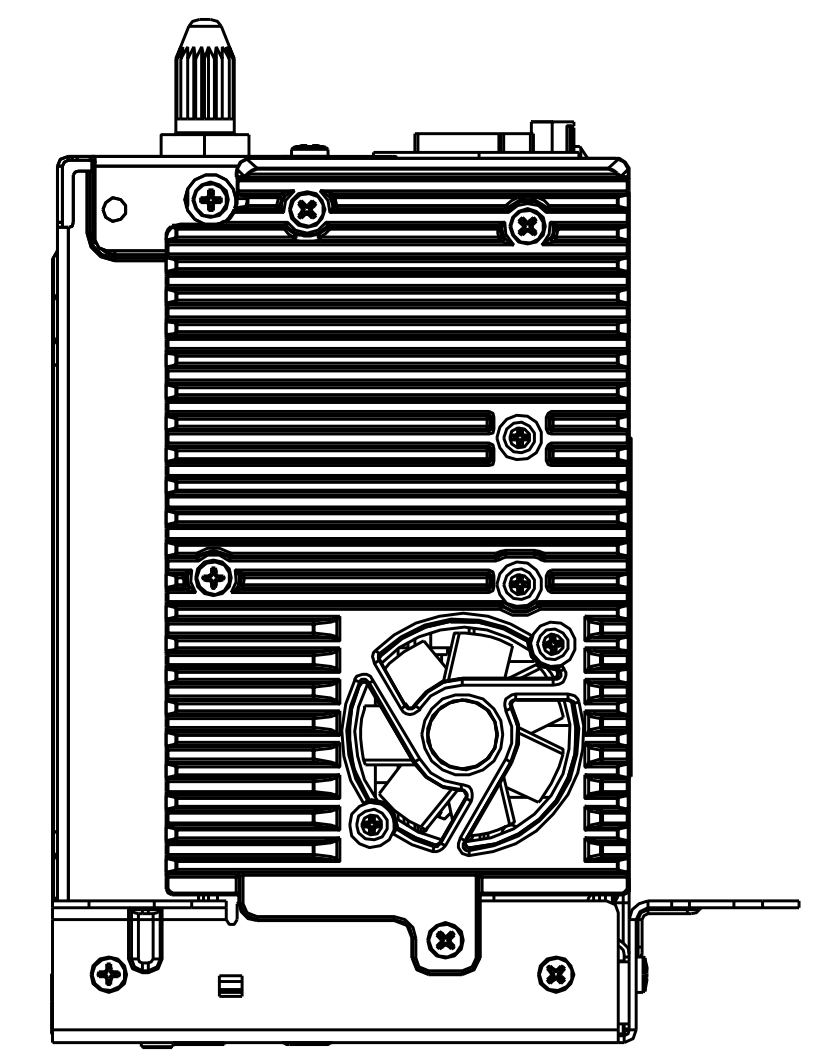

CDT RIGHT
SIDE VIEW

CDT+XM RIGHT
SIDE VIEW

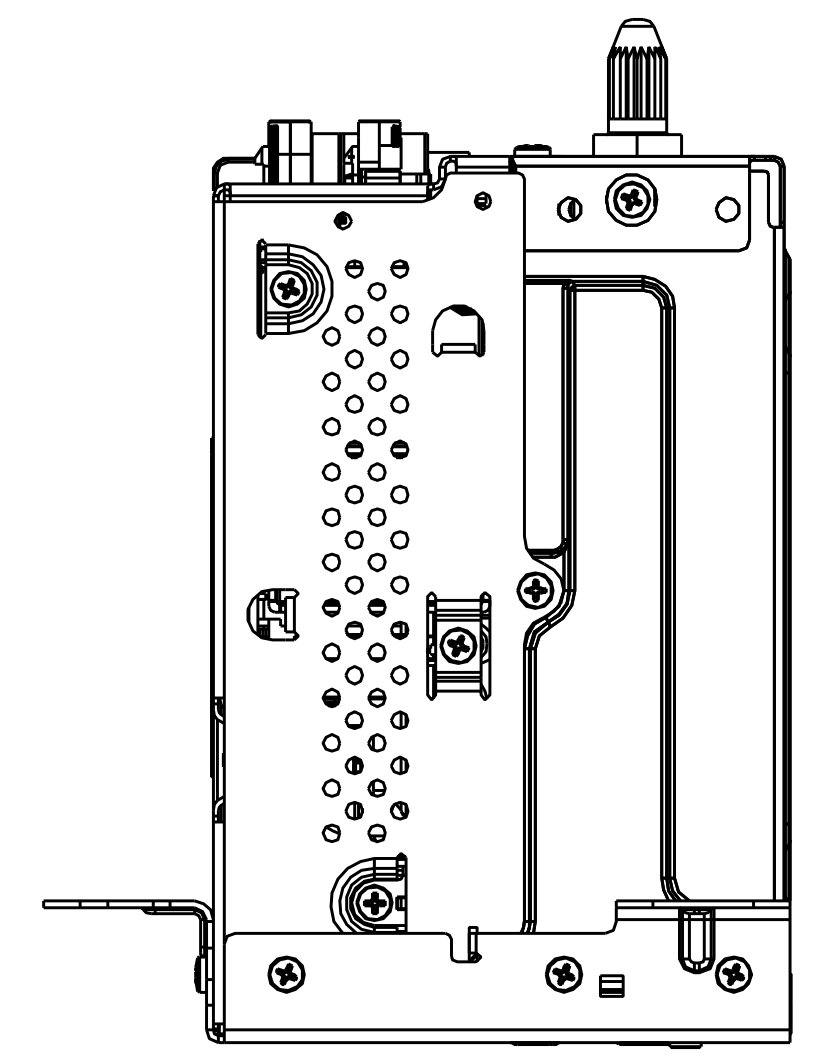
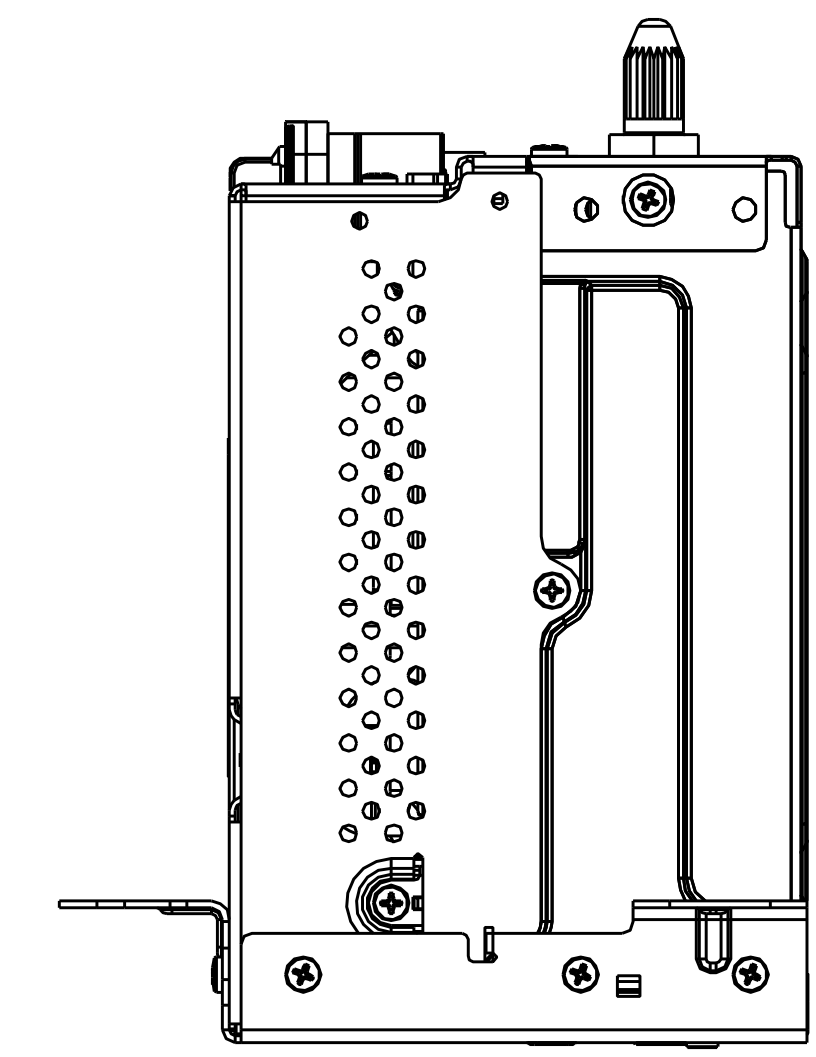

PIN	FUNCTION
1	RSAudioShield
2	CGI-
3	CGIShield
4	CanrSpkrOut-
5	Snt5_IOut-
6	MoncMixIn-
7	AuxSIInR-
8	AuxSIInL-
9	AuxSIInShield
10	AuxJackInR
11	AuxJackDelCl
12	RSAudioCommca
13	CenterStackWake
14	LSGMLAN2
15	TelephonMute
16	CGI+
17	Center/subShield
18	CanrSpkrOut+
19	Snt5_IOut+
20	MoncMixIn+
21	AuxSIInR+
22	AuxSIInL+
23	AuxJackInCom
24	AuxJackInL
25	RSAudioL
26	RSAudioR
27	CenterStackResel
28	LSGMLAN1

PIN	FUNCTION
29	FrontShield
30	RearShield
31	RFSpkrOut-
32	LFSpkrOut-
33	RRSpkrOut-
34	LRSpkrOut-
35	ICB+
36	ICB-
37	AmpControl
38	Ground
39	RFSpkrOut+
40	LFSpkrOut+
41	RRSpkrOut+
42	LRSpkrOut+
43	RmlEnable
44	Ball

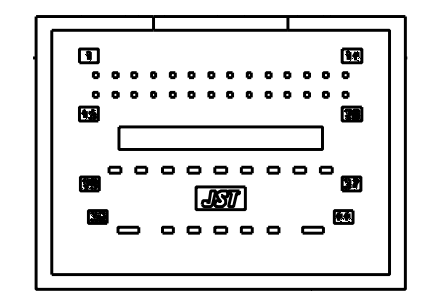

MAIN CONNECTOR J1 (JST 44 WAY)
PIN OUT DIAGRAM

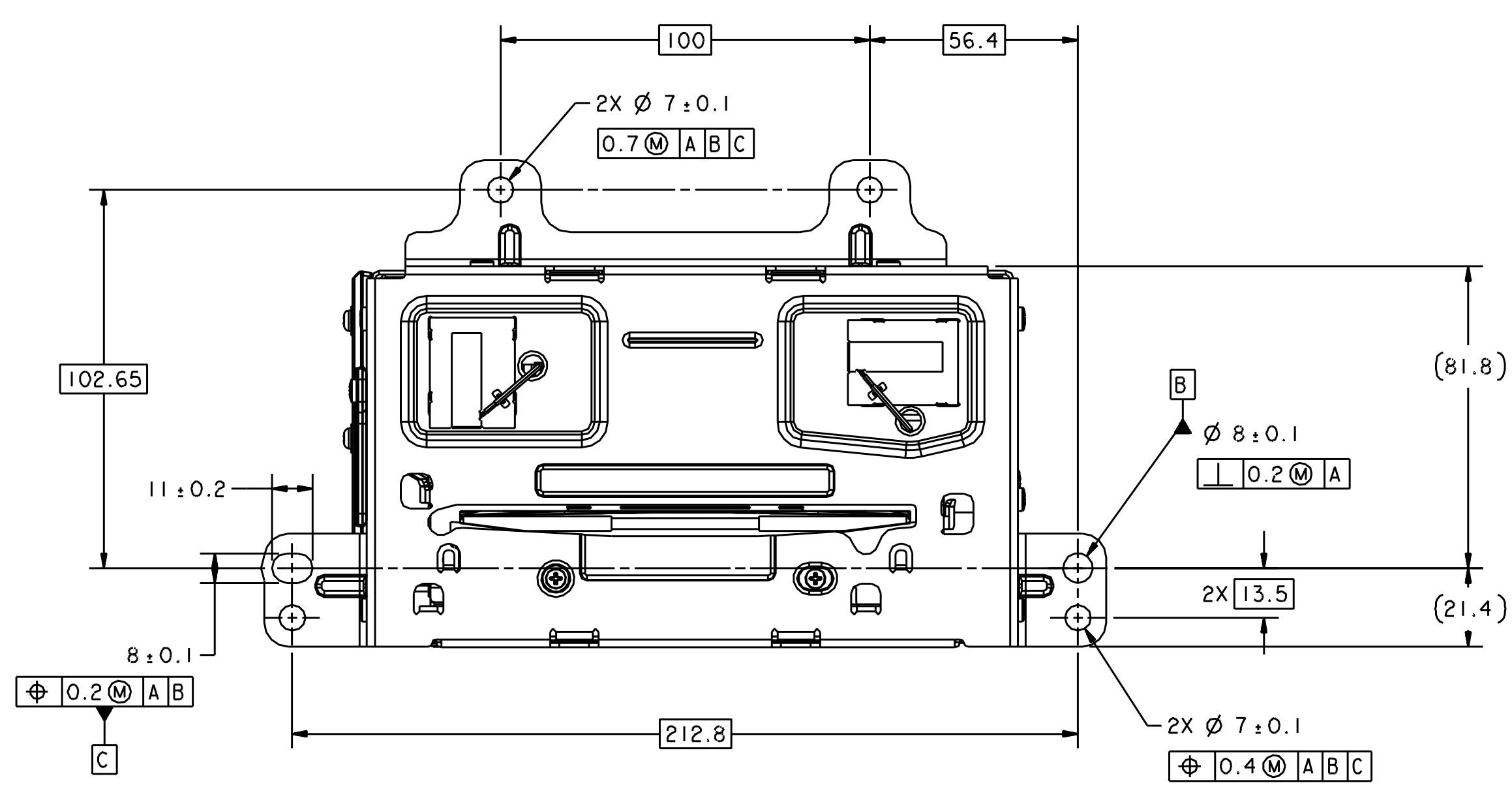

PIN	Function
1	DGND (VIC51)
2	DGND (VIC52)
3	DGND (VIC53)
4	PopUpPosCall1
5	RVSVideoIn+
6	DGND (MicIn+)
7	DGND (AuxFromInOut+)
8	DGND (T-sscreen_Shield)
9	Touch screen +
10	Touch Screen Resel
11	DGND (VIC54)
12	VIC55
13	PopUpPosSense
14	DGND (NAVDspDm)
15	RVSVideoIn-
16	DGND (MicIn-)
17	DGND (AuxFromInOut-)
18	DGND (AuxFromInShield)
19	Touch screen -
20	DistancePulseIn

CONNECTOR J4 (20 PIN USCAR)
PIN OUT DIAGRAM

1/27/2012	RELEASE TO PRODUCTION PER ECO #002293		
SYM. DATE	REVISION	SIGNED	CHECKED

MASTER_00.MY13.CCR-DR-TABULATED_OUTSIDEVIEW.DWG.pr1

SYM.	ITEM OR PART NO.	NAME	QTY	MATERIAL & SIZE	TREATMENT	REMARK

UNIT:MM	SCALE: 1:1	DESIGN: 1/14/2011	DRAWN: 1/14/2011	CHECKED: 3/27/2012	APPROVED:
---------	------------	-------------------	------------------	--------------------	-----------

TYPE	OUTSIDE VIEW DRAWING, CONNECTED COLOR RADIO TOP/SIDE MOUNTING
DWG NAME	MY13 CCR CDT+BT+WIFI
DWG OR PART NUMBER	M3T475683 /00
REF. NO.	

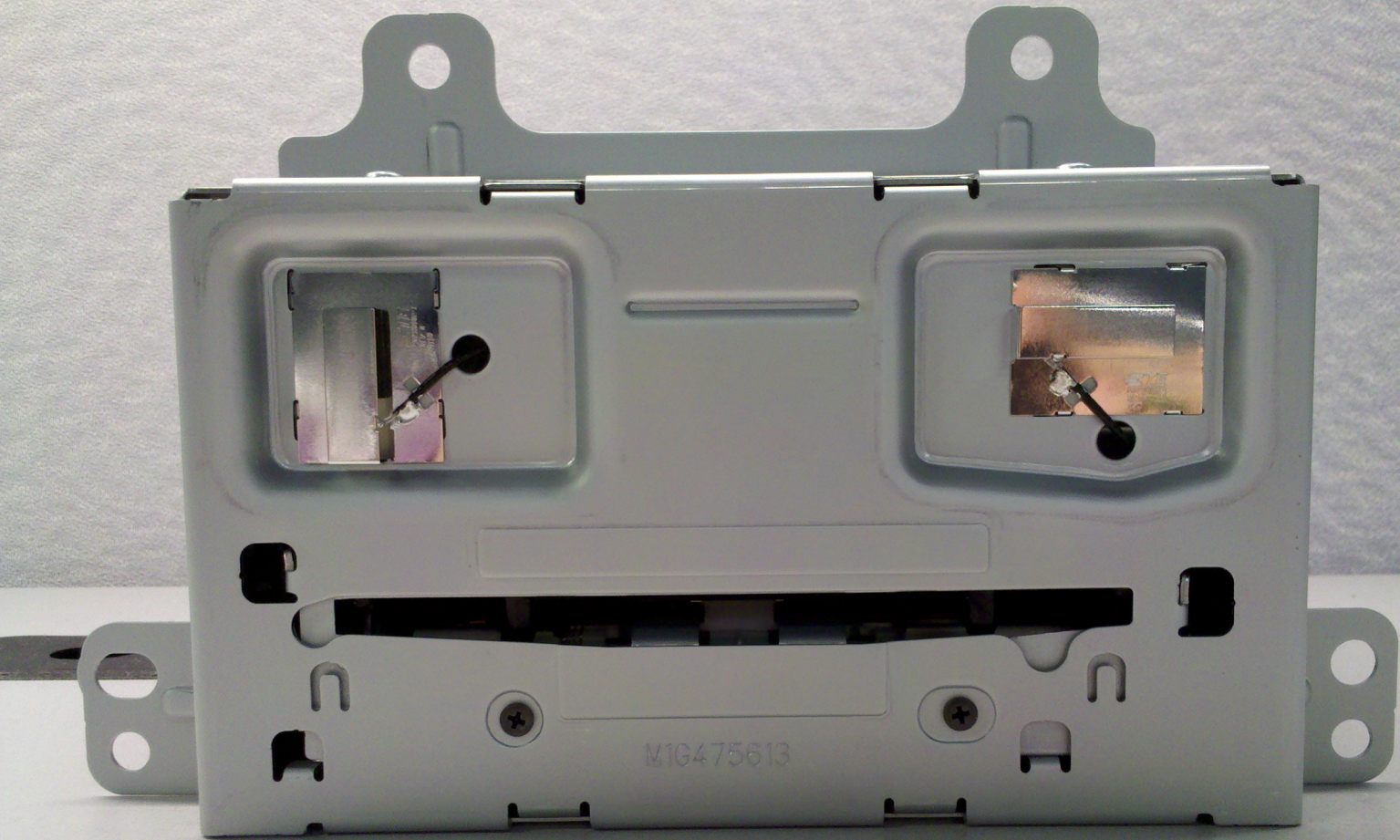

M1G475613





