

TEST REPORT

of

FCC Part 15 Subpart C AND CANADA RSS-210

New Application; Class I PC; Class II PC

Product : Connected Color Radio
Brand: Panasonic
Model: GA-120-COLR-NS
Model Difference: N/A
FCC ID: ACJ-GA-120-COLR
IC: 216B-GA120COLRNS
FCC Rule Part: §15.247, Cat: DSS
IC Rule Part: RSS-210 issue 8:2010, Annex 8
Applicant: Panasonic Corporation of North America
Address: One Panasonic Way, 4B-8, Secaucus, New Jersey, 07094, United States

Test Performed by:

International Standards Laboratory

<Lung-Tan LAB>

*Site Registration No.

BSMI: SL2-IN-E-0013; MRA TW1036; TAF: 0997; IC: IC4067B-3;

*Address:

No. 120, Lane 180, San Ho Tsuen, Hsin Ho Rd.

Lung-Tan Hsiang, Tao Yuan County 325, Taiwan

*Tel : 886-3-407-1718; Fax: 886-3-407-1738

Report No.: **ISL-11LR070FC**

Issue Date : **2011/09/30**



Test results given in this report apply only to the specific sample(s) tested and are traceable to national or international standard through calibration of the equipment and evaluating measurement uncertainty herein.

This report MUST not be used to claim product endorsement by TAF, NVLAP or any agency of the Government.

This test report shall not be reproduced except in full, without the written approval of International Standards Laboratory.



VERIFICATION OF COMPLIANCE

Applicant: Panasonic Corporation of North America
Product Description: Connected Color Radio
Brand Name: Panasonic
Model No.: GA-120-COLR-NS
Model Difference: N/A
FCC ID: ACJ-GA-120-COLR
IC: 216B-GA120COLRNS
FCC Rule Part: §15.247
IC Rule Part: RSS-210 issue 8:2010, Annex 8
Date of test: 2011/09/06 ~ 2011/09/28
Date of EUT Received: 2011/09/06

We hereby certify that:

All the tests in this report have been performed and recorded in accordance with the standards described above and performed by an independent electromagnetic compatibility consultant, International Standards Laboratory.

The test results contained in this report accurately represent the measurements of the characteristics and the energy generated by sample equipment under test at the time of the test. The sample equipment tested as described in this report is in compliance with the limits of above standards.

Test By:	 _____ <i>Dion Chang / Engineer</i>	Date:	2011/09/30 _____
Prepared By:	 _____ <i>Eva Kao / Technical Supervisor</i>	Date:	2011/09/30 _____
Approved By:	 _____ <i>Vincent Su / Technical Manager</i>	Date:	2011/09/30 _____

Version

Version No.	Date	Description
00	2011/09/30	Initial creation of document

Table of Contents

1. GENERAL INFORMATION	6
1.1. Product Description	6
1.2. Related Submittal(s) / Grant (s)	7
1.3. Test Methodology	7
1.4. Test Facility	7
1.5. Special Accessories	7
1.6. Equipment Modifications	7
2. SYSTEM TEST CONFIGURATION	8
2.1. EUT Configuration	8
2.2. EUT Exercise	8
2.3. Test Procedure	8
2.4. Configuration of Tested System	9
3. SUMMARY OF TEST RESULTS	10
4. DESCRIPTION OF TEST MODES	10
5. AC POWER LINE CONDUCTED EMISSION TEST	11
5.1. Standard Applicable:	11
5.2. Measurement Equipment Used:	11
5.3. EUT Setup:	11
5.4. Measurement Procedure:	12
5.5. Measurement Result:	12
6. PEAK OUTPUT POWER MEASUREMENT	13
6.1. Standard Applicable:	13
6.2. Measurement Equipment Used:	13
6.3. Test Set-up:	14
6.4. Measurement Procedure:	14
6.5. Measurement Result:	15
7. 100KHz BANDWIDTH OF BAND EDGES MEASUREMENT	20
7.1. Standard Applicable:	20
7.2. Measurement Equipment Used:	21
7.3. Test SET-UP:	22
7.4. Measurement Procedure:	23
7.5. Field Strength Calculation	23
7.6. Measurement Result:	23

8. SPURIOUS EMISSION TEST	28
8.1. Standard Applicable:	28
8.2. Measurement Equipment Used:	28
8.3. Test SET-UP:.....	28
8.4. Measurement Procedure:	29
8.5. Field Strength Calculation	29
8.6. Measurement Result:	29
9. FREQUENCY SEPARATION	45
9.1. Standard Applicable:	45
9.2. Measurement Equipment Used:	45
9.3. Test Set-up:	45
9.4. Measurement Procedure:	45
9.5. Measurement Result:	45
10. NUMBER OF HOPPING FREQUENCY	47
10.1. Standard Applicable:	47
10.2. Measurement Equipment Used:	47
10.3. Test Set-up:	47
10.4. Measurement Procedure:	47
10.5. Measurement Result:	47
11. TIME OF OCCUPANCY (DWELL TIME)	49
11.1. Standard Applicable:	49
11.2. Measurement Equipment Used:	49
11.3. Test Set-up:	49
11.4. Measurement Procedure:	49
11.5. Measurement Result:	50
12. 20dB Bandwidth & 99% Bandwidth	56
12.1. Standard Applicable:	56
12.2. Measurement Equipment Used:	56
12.3. Test Set-up:	56
12.4. Measurement Procedure:	56
12.5. Measurement Result:	57
13. ANTENNA REQUIREMENT	66
13.1. Standard Applicable:	66
13.2. Antenna Connected Construction:	66

1. GENERAL INFORMATION

1.1. Product Description

General:

Product Name	Connected Color Radio
Brand Name	Panasonic
Model Name	GA-120-COLR-NS
Model Difference	N/A
Power Supply	12Vdc for car battery

Bluetooth:

Frequency Range:	2402 – 2480MHz
Bluetooth Version:	V2.1 + EDR (GFSK + $\pi/4$ DQPSK + 8DPSK)
Channel number:	79 channels
Modulation type:	Frequency Hopping Spread Spectrum
Transmit Power:	2.42 dBm
Dwell Time:	$\leq 0.4s$
Operating Mode:	Point-to-Point
Antenna Designation:	PIFA Antenna, 4dBi.
Type of Emission:	1M74FXD

The EUT is compliance with Bluetooth 2.1 + EDR Standard.

1.2. Related Submittal(s) / Grant (s)

This submittal(s) (test report) is intended for **FCC ID: ACJ-GA-120-COLR** filing to comply with Section 15.247 of the FCC Part 15C, Subpart C Rules. And **IC: 216B-GA120COLRNS** filing to comply with Industry Canada RSS-210 issue 8: 2010 Annex 8.

1.3. Test Methodology

Both conducted and radiated testing were performed according to the procedures in ANSI C63.4 (2003) and RSS-Gen: 2010. Radiated testing was performed at an antenna to EUT distance 3 meters.

Tested in accordance with FCC Public Notice DA 00-705

1.4. Test Facility

The measurement facilities used to collect the 3m Radiated Emission and AC power line conducted data are located on the address of **International Standards Laboratory** <Lung-Tan LAB> No. 120, Lane 180, San Ho Tsuen, Hsin Ho Rd., Lung-Tan Hsiang, Tao Yuan County 325, Taiwan which are constructed and calibrated to meet the FCC requirements in documents ANSI C63.4: 2003. FCC Registration Number is: TW1036, Canada Registration Number: 4067B-3.

1.5. Special Accessories

Not available for this EUT intended for grant.

1.6. Equipment Modifications

Not available for this EUT intended for grant.

2. SYSTEM TEST CONFIGURATION

2.1. EUT Configuration

The EUT configuration for testing is installed on RF field strength measurement to meet the Commissions requirement and operating in a manner which intends to maximize its emission characteristics in a continuous normal application.

2.2. EUT Exercise

The EUT (Transmitter) was tested with a test program to fix the Tx/RX frequency that was for the purpose of the measurements. For more information please see test data and APPENDIX 1 for set-up photographs.

2.3. Test Procedure

2.3.1 Conducted Emissions

The EUT is placed on a turn table which is 0.8 m above ground plane. According to the requirements in Section 7, 13 of ANSI C63.4-2003 and RSS-Gen:2010. Conducted emissions from the EUT measured in the frequency range between 0.15 MHz and 30MHz using CISPR Quasi-Peak and Average detector mode.

2.3.2 Radiated Emissions

The EUT is placed on a turn table which is 0.8 m above ground plane. The turn table shall rotate 360 degrees to determine the position of maximum emission level. EUT is set 3m away from the receiving antenna which varied from 1m to 4m to find out the highest emission. And also, each emission was to be maximized by changing the polarization of receiving antenna both horizontal and vertical. In order to find out the max. emission, the relative positions of this hand-held transmitter (EUT) was rotated through three orthogonal axes and measurement procedures for electric field radiated emissions above 1 GHz the EUT measurement is to be made “while keeping the antenna in the ‘cone of radiation’ from that area and pointed at the area both in azimuth and elevation, with polarization oriented for maximum response.” is still within the 3dB illumination BW of the measurement antenna. according to the requirements in Section 8 and 13 of ANSI C63.4-2003 and DA 00-705..

2.4. Configuration of Tested System

Fig. 2-1 Configuration of Tested System (Fixed channel)

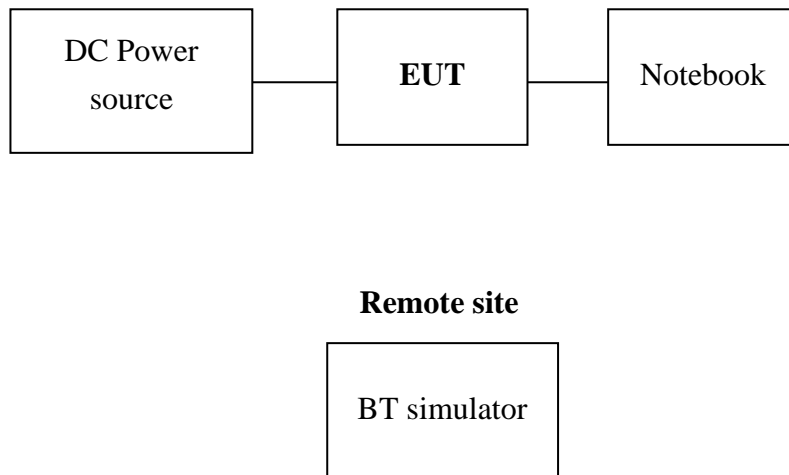

Table 2-1 Equipment Used in Tested System

Item	Equipment	Mrf/Brand	Model name	Series No	Data Cable	Power Cable
1	BT simulator	Agilent	N4010A	N/A	N/A	Non-shield
2	Power Source	ABM	8185D	N/A	N/A	Non-shield
3	Notebook	Acer	JE50	N/A	N/A	Non-shield

3. SUMMARY OF TEST RESULTS

FCC Rules	Description Of Test	Result
§15.207(a)/ RSS-Gen §7.2.2	AC Power line Conducted Emission	N/A
§15.247(b)(1)/ RSS-210 issue 8,§A8.4(2)	Peak Output Power	Compliant
§15.247(d) RSS-210 issue 8,§A8.5	100 KHz Bandwidth Of Frequency Band Edges	Compliant
§15.247(c) RSS-Gen §7.2.3 RSS-210 issue 8,§A2.9	TX/RX Spurious Emission	Compliant
§15.247(a)(1)/ RSS-210 issue 8,§A8.1(b)	Frequency Separation	Compliant
§15.247(a)(1)(iii)/ RSS-210 issue 8,§A8.1(d)	Number of hopping frequency	Compliant
§15.247(a)(1)(ii)/ RSS-210 issue 8,§A8.1(d)	Time of Occupancy	Compliant
§15.247/ RSS-210 issue 8,§A8.2(b)	Peak Power Density	Compliant
§15.247(a)(1) RSS210 issue ,§A8.1(b)	20dB Bandwidth & 99% Power Bandwidth	Compliant
§15.203, §15.247(c)/ RSS-GEN 7.1.4, RSS-210 issue 8,§A8.4	Antenna Requirement	Compliant

4. DESCRIPTION OF TEST MODES

The EUT has been tested under operating condition.

Test program used to control the EUT for staying in continuous transmitting and receiving mode is programmed.

Channel low (2402MHz) 、 mid (2441MHz) and high (2480MHz) with highest data rate are chosen for full testing.

5. AC POWER LINE CONDUCTED EMISSION TEST

5.1. Standard Applicable:

According to §15.207 and RSS-Gen §7.2.2, frequency range within 150KHz to 30MHz shall not exceed the Limit table as below.

Frequency range MHz	Limits dB(uV)	
	Quasi-peak	Average
0.15 to 0.50	66 to 56	56 to 46
0.50 to 5	56	46
5 to 30	60	50

Note

- 1.The lower limit shall apply at the transition frequencies
- 2.The limit decreases linearly with the logarithm of the frequency in the range 0.15 MHz to 0.50 MHz.

5.2. Measurement Equipment Used:

AC Power Line Test Site					
EQUIPMENT TYPE	MFR	MODEL NUMBER	SERIAL NUMBER	LAST CAL.	CAL DUE.
Conduction 03 -1 Cable	WOKEN	CFD 300-NL	Conduction 0-1	06/27/2011	06/27/2012
EMI Receiver 12	ROHDE & SCHWARZ	ESCI	100804	06/25/2011	06/25/2012
LISN 07	FCC Inc.	FCC-LISN-50-100-4 -02	07040	06/02/2011	06/02/2012
LISN 08	FCC	FCC-LISN50-25-2-0 1	07039	06/25/2011	06/25/2012

5.3. EUT Setup:

1. The conducted emission tests were performed in the test site, using the setup in accordance with the ANSI C63.4-2003.
2. The AC/DC Power adaptor of EUT was plug-in LISN. The EUT was placed flushed with the rear of the table.
3. The LISN was connected with 120Vac/60Hz power source.

5.4. Measurement Procedure:

1. The EUT was placed on a table which is 0.8m above ground plane.
2. Maximum procedure was performed on the six highest emissions to ensure EUT compliance.
3. Repeat above procedures until all frequency measured were complete.

5.5. Measurement Result:

N/A, The power supply is 12V DC.

6. PEAK OUTPUT POWER MEASUREMENT

6.1. Standard Applicable:

According to §15.247(b)(1), For frequency hopping systems operating in the 2400-2483.5 MHz band employing at least 75 hopping channels, and all frequency hopping systems in the 5725-5850MHz band: 1Watt. For all other frequency hopping systems in the 2400 – 2483.5MHz band: 0.125 Watts.

According to RSS-210 issue 8,§A8.4(2), For frequency hopping systems operating in the 2400-2483.5 MHz band employing at least 75 hopping channels, the maximum conducted output power shall not exceed 1 W. For all other frequency hopping systems, the maximum peak conducted output power shall not exceed 0.125 W.

6.2. Measurement Equipment Used:

Conducted Emission Test Site					
EQUIPMENT TYPE	MFR	MODEL NUMBER	SERIAL NUMBER	LAST CAL.	CAL DUE.
Power Meter 05	Anritsu	ML2495A	1116010	04/22/2011	04/21/2012
Power Sensor 05	Anritsu	MA2411B	34NKF50	04/22/2011	04/21/2012
Spectrum Analyzer 19	R&S	FSP40	100116	10/18/2010	10/18/2011
Spectrum Analyzer 20	Agilent	E4443A	MY48250315	05/12/2011	05/11/2012
Temperature Chamber	KSON	THS-B4H100	2287	03/03/2011	03/03/2012
DC Power supply	ABM	51850	N/A	06/17/2011	06/16/2012

6.3. Test Set-up:

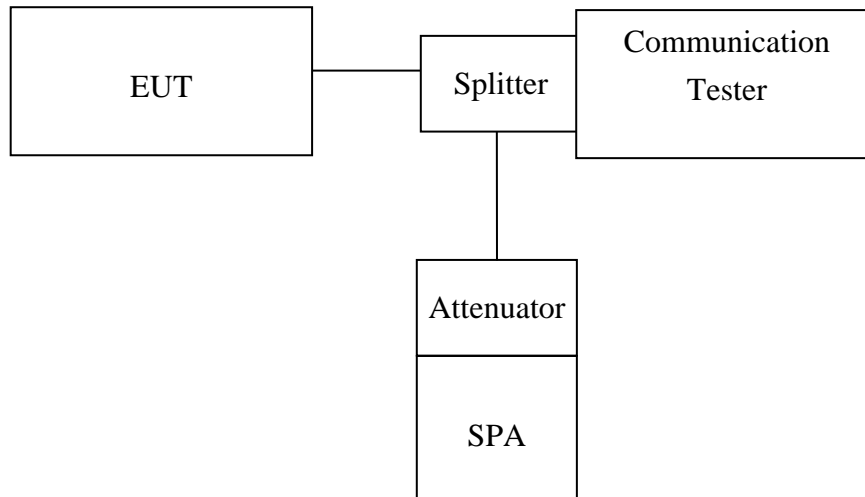

6.4. Measurement Procedure:

1. Place the EUT on the table and set it in transmitting mode.
2. Remove the antenna from the EUT and then connect a low loss RF cable from the antenna port to the power meter or spectrum. (Channel power function, RBW, VBW > 20 dB bandwidth)
3. Record the max. reading.
4. Repeat above procedures until all frequency measured were complete.

6.5. Measurement Result:

BDR Mode

Frequency (MHz)	Reading Power (dBm)	Cable Loss	Output Power (dBm)	Output Power (W)	Limit (W)
2402.00	2.42	0.00	2.42	0.00175	1
2441.00	1.49	0.00	1.49	0.00141	1
2480.00	1.40	0.00	1.40	0.00138	1

EDR Mode

Frequency (MHz)	Reading Power (dBm)	Cable Loss	Output Power (dBm)	Output Power (W)	Limit (W)
2402.00	1.96	0.00	1.96	0.00157	1
2441.00	1.25	0.00	1.25	0.00133	1
2480.00	1.94	0.00	1.94	0.00156	1

offset: 8dB

Note: Refer to next page for plots.

Peak Power Output Data Plot (CH Low) (BDR mode)

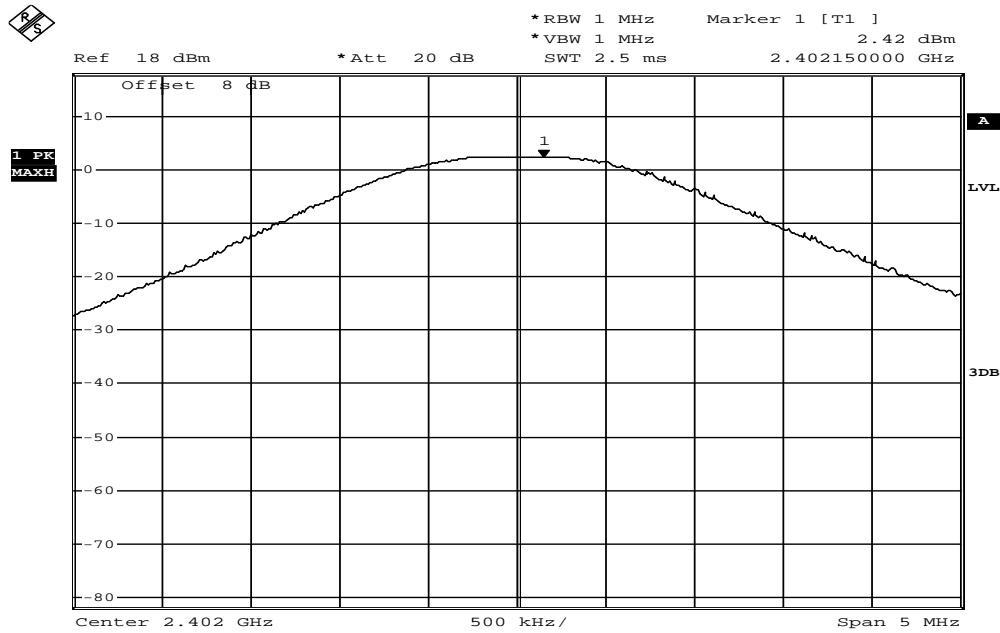

Date: 19.SEP.2011 14:13:04

Peak Power Output Data Plot (CH Mid) (BDR mode)

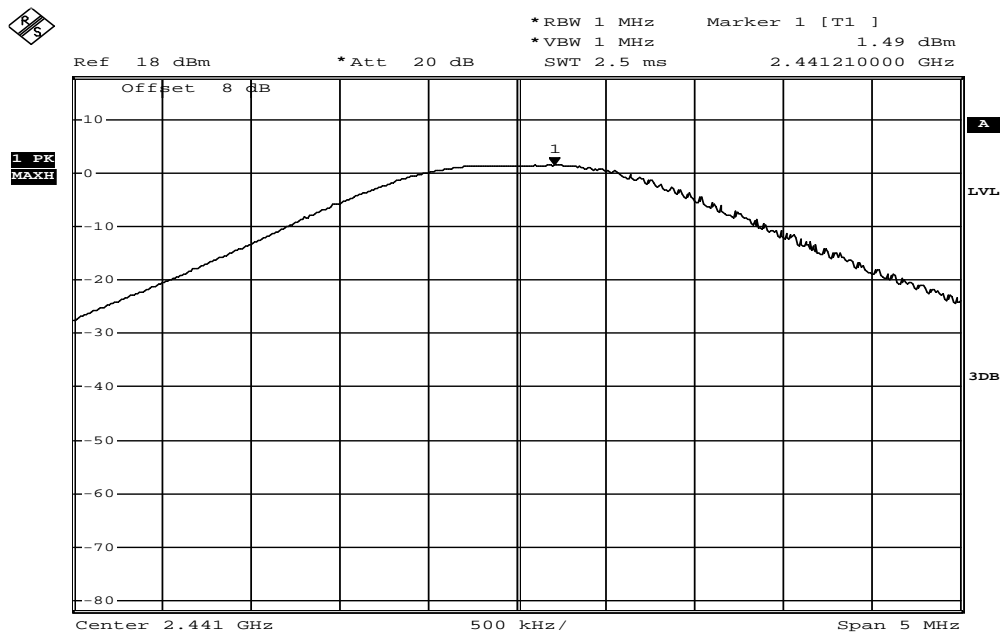

Date: 19.SEP.2011 14:14:37

Peak Power Output Data Plot (CH High) (BDR mode)



Date: 19.SEP.2011 14:15:10

Peak Power Output Data Plot (CH Low) (EDR mode)

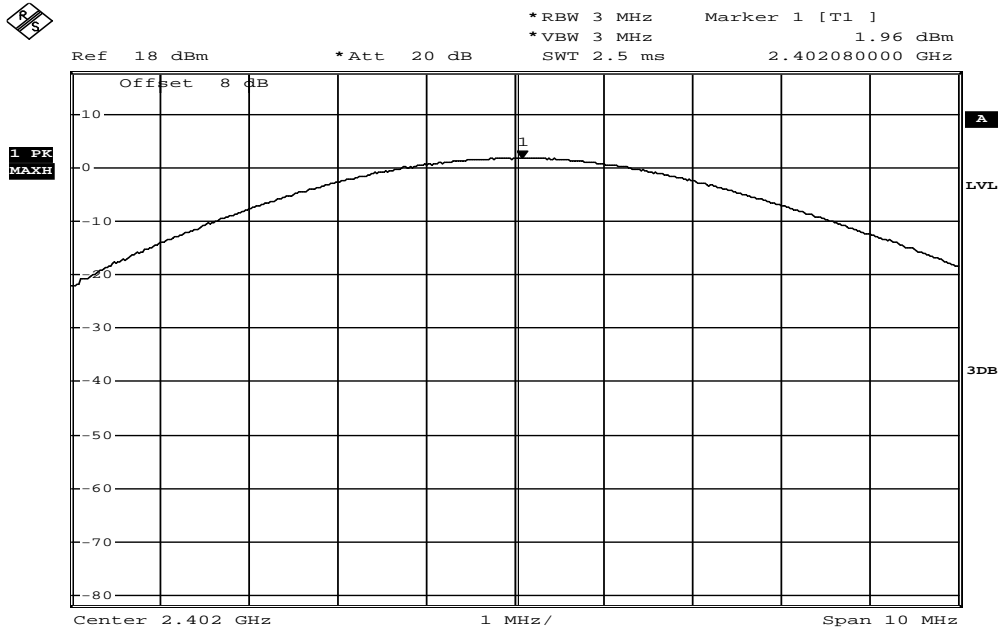

Date: 30.SEP.2011 14:34:15

Peak Power Output Data Plot (CH Mid) (EDR mode)

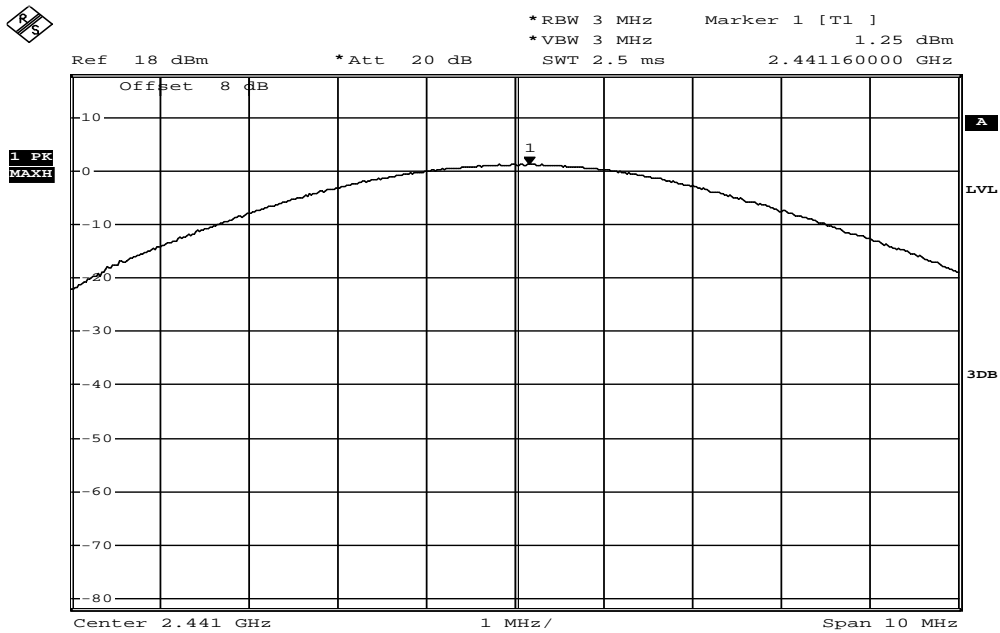

Date: 30.SEP.2011 14:34:46

Peak Power Output Data Plot (CH High) (EDR mode)

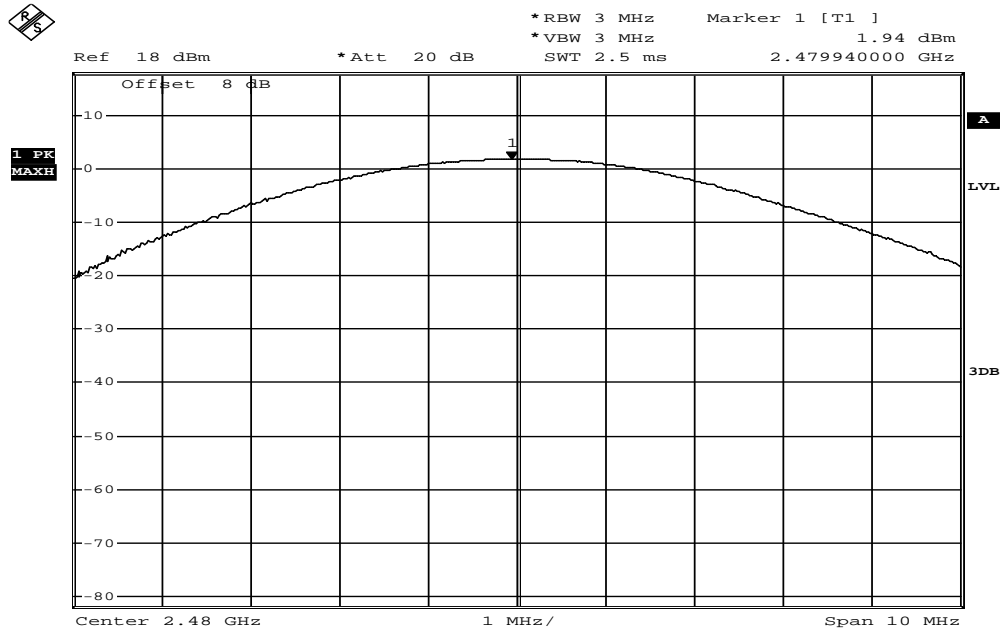

Date: 30.SEP.2011 14:35:08

7. 100KHz BANDWIDTH OF BAND EDGES MEASUREMENT

7.1. Standard Applicable:

According to §15.247(d), in any 100 KHz bandwidth outside the frequency bands in which the spread spectrum intentional radiator is operating, the radio frequency power that is produced by the intentional radiator shall be at least 20dB below that in the 100KHz bandwidth within the band that contains the highest level of the desired power. In addition, radiated emissions which fall in the restricted bands, as defined in §15.205(a), must also comply with the radiated emission limits specified in §15.209(a).

According to RSS-210 issue 8, §A8.5, In any 100 kHz bandwidth outside the frequency band in which the spread spectrum or digitally modulated device is operating, the radio frequency power that is produced shall be at least 20 dB below that in the 100 kHz bandwidth within the band that contains the highest level of the desired power, based on either an RF conducted or a radiated measurement, provided the transmitter demonstrates compliance with the peak conducted power limits. If the transmitter complies with the conducted power limits based on the use of RMS averaging over a time interval, as permitted under section A8.4(4), the attenuation required shall be 30 dB instead of 20 dB. Attenuation below the general limits specified in Tables 2 and 3 is not required. In addition, radiated emissions which fall in the restricted bands of Table 1 must also comply with the radiated emission limits specified in Tables 2 and 3.

7.2. Measurement Equipment Used:

7.2.1. Conducted Emission at antenna port:

Refer to section 6.2 for details.

7.2.2. Radiated emission:

Chamber 14(966)					
EQUIPMENT TYPE	MFR	MODEL NUMBER	SERIAL NUMBER	LAST CAL.	CAL DUE.
Spectrum Analyzer 21	Agilent	N9010A	MY49060537	07/18/2011	07/17/2012
Spectrum Analyzer 19	R&S	FSP40	100116	10/18/2010	10/17/2011
Spectrum Analyzer 20	Agilent	E4443A	MY48250315	05/12/2011	05/11/2012
Short Dipole antenna	Schwarzbeck Mess-Elektronik	VHAA9110	NA	07/17/2011	07/16/2012
Dipole antenna	SCHWARZBECK	VHAP&HUA P	NA	07/17/2011	07/16/2012
Dipole antenna	SCHWARZBECK	UHA9105	NA	07/17/2011	07/16/2012
Loop Antenna	A.H.SYSTEM	SAS-564	294	02/28/2011	02/27/2012
Bilog Antenna	Schaffner	CBL 6111D	22612	03/30/2011	03/29/2012
Horn antenna(06)	EMCO	3117	0006665	09/28/2010	09/27/2011
Horn antenna(05)	Com-power	AH-640	100A	01/11/2011	01/10/2013
Horn antenna(04)	Com-power	AH-826	081001	05/04/2011	05/03/2013
Horn antenna(02)	EMCO	AH118	0006665	02/15/2011	02/14/2012
Preamplifier	HP	8447F	NA	05/04/2011	05/03/2012
Preamplifier 15	Agilent	8449B	3008A2471	02/16/2011	02/15/2012
Cable	Huber Suhner	Sucoflex 106	NA	02/09/2011	02/08/2012
Cable	Pacific	8D-FB	NA	10/18/2010	10/17/2011
Signal Generator	R&S	SMU200A	NA	10/12/2010	10/11/2011

7.3. Test SET-UP:

7.3.1. Conducted Emission at antenna port:

Refer to section 6.3 for details.

7.3.2. Radiated emission:

(A) Radiated Emission Test Set-Up, Frequency Below 1000MHz

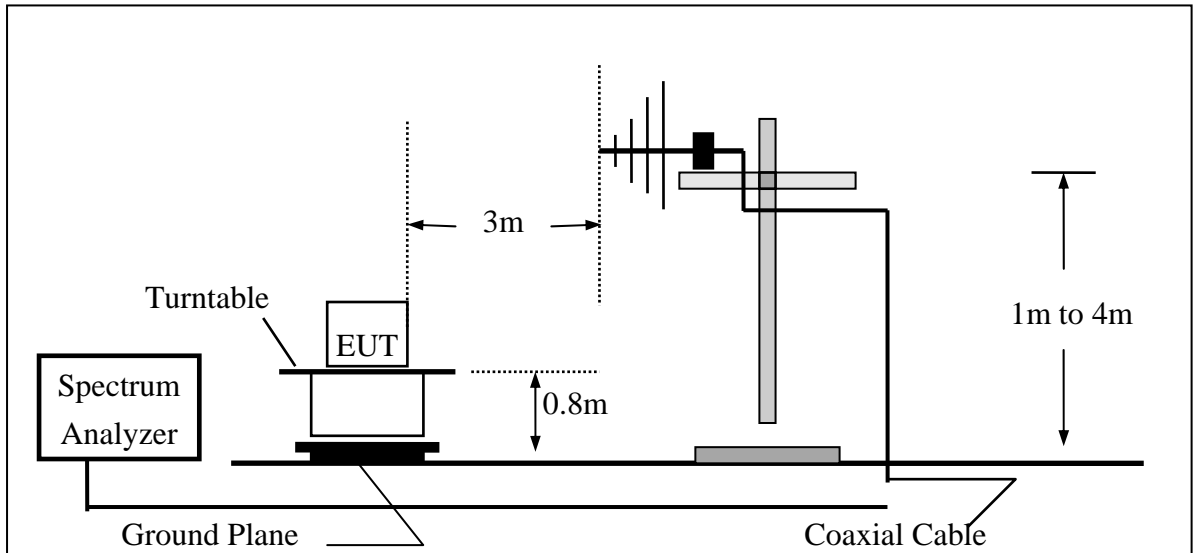

(B) Radiated Emission Test Set-UP Frequency Over 1 GHz

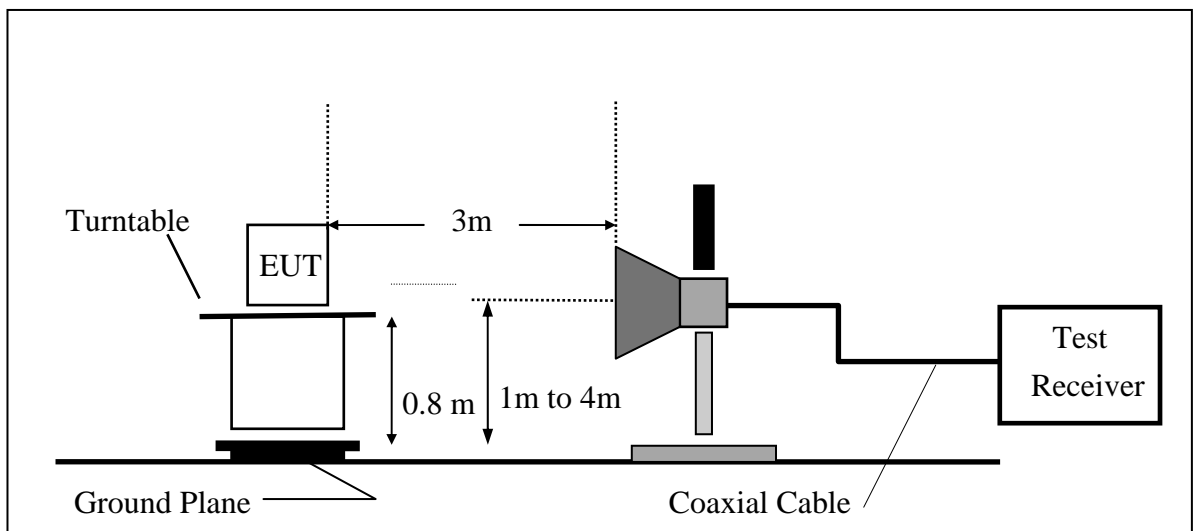

7.4. Measurement Procedure:

1. Place the EUT on the table and set it in transmitting mode.
2. Remove the antenna from the EUT and then connect a low loss RF cable from the antenna port to the spectrum analyzer.
3. Set center frequency of spectrum analyzer = operating frequency.
4. Set the spectrum analyzer as RBW, VBW=100KHz, Span=25MHz, Sweep = auto
5. Mark Peak, 2.390GHz and 2.4835GHz and record the max. level.
6. Repeat above procedures until all frequency measured were complete.

7.5. Field Strength Calculation

The field strength is calculated by adding the Antenna Factor and Cable Factor and subtracting the Amplifier Gain and Duty Cycle Correction Factor(if any) from the measured reading. The basic equation with a sample calculation is as follows:

$$FS = RA + AF + CL - AG$$

Where	FS = Field Strength	CL = Cable Attenuation Factor (Cable Loss)
	RA = Reading Amplitude	AG = Amplifier Gain
	AF = Antenna Factor	

7.6. Measurement Result:

Note: Refer to next page spectrum analyzer data chart and tabular data sheets.

BDR Mode
Band Edges Test Data CH-Low

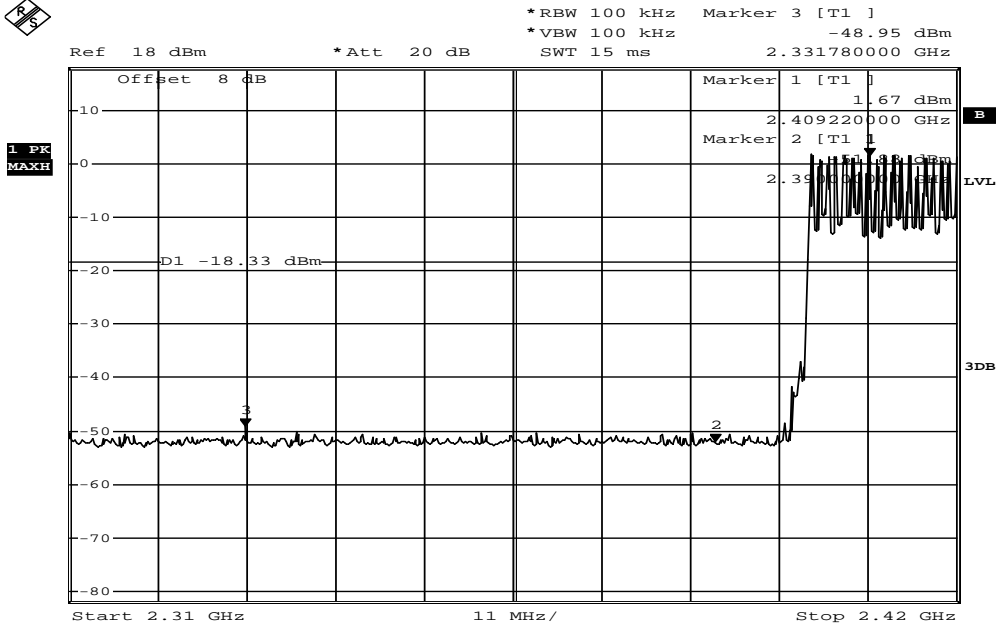

Date: 19.SEP.2011 15:01:17

Band Edges Test Data CH-High

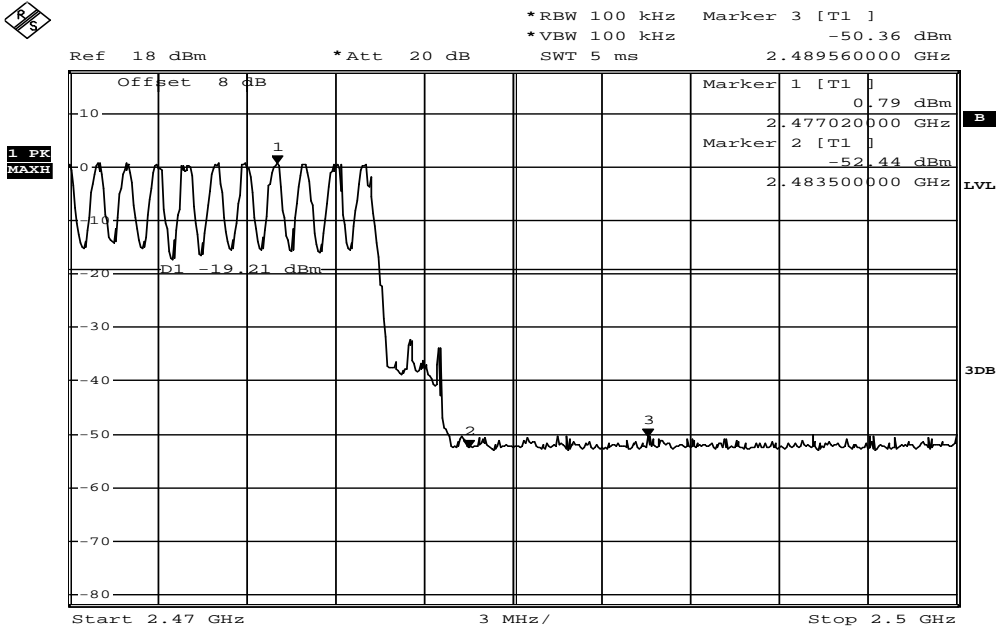

Date: 19.SEP.2011 15:03:07

Radiated Emission: (BDR mode)

Operation Mode TX CH Low
Fundamental Frequency 2402 MHz
Temperature 25 °C

Test Date 2011/09/20
Test By Dino
Humidity 60 %

No	Freq MHz	Reading dBuV	Factor dB	Level dBuV/m	Limit dBuV/m	Over Limit dB	Remark	Pol V/H
1	2328.69	37.22	-1.12	36.10	54.00	-17.90	Average	VERTICAL
2	2328.69	56.22	-1.12	55.10	74.00	-18.90	Peak	VERTICAL
3	2390.00	44.90	-1.06	43.84	74.00	-30.16	Peak	VERTICAL
1	2325.72	48.49	-1.12	47.37	74.00	-26.63	Peak	HORIZONTAL
2	2390.00	42.99	-1.06	41.93	74.00	-32.07	Peak	HORIZONTAL

Operation Mode TX CH High
Fundamental Frequency 2480 MHz
Temperature 25 °C

Test Date 2011/09/20
Test By Dino
Humidity 60 %

No	Freq MHz	Reading dBuV	Factor dB	Level dBuV/m	Limit dBuV/m	Over Limit dB	Remark	Pol V/H
1	2483.50	38.98	-0.96	38.02	54.00	-15.98	Average	VERTICAL
2	2483.50	58.99	-0.96	58.03	74.00	-15.97	Peak	VERTICAL
1	2483.50	51.54	-0.96	50.58	74.00	-23.42	Average	HORIZONTAL

Remark:

- 1 Measuring frequencies from the lowest internal frequency to the 10th of fundamental frequency
- 2 Field strength limits for frequency above 1000MHz are based on average limits. However, Peak mode field strength shall not exceed the average limits specified plus 20dB.
- 3 "F" denotes fundamental frequency; "H" denotes harmonics frequency. "S" denotes spurious frequency.
- 4 Measurement of data within this frequency range shown " - " in the table above means the reading of emissions are attenuated more than 20dB below the permissible limits or the field strength is too small to be measured.
- 5 Spectrum Peak mode IF bandwidth Setting : 1GHz- 26GHz, RBW= 1MHz, Sweep time= 200 ms., the VBW setting was 3 MHz.
- 6 Spectrum AV mode if bandwidth Setting : 1GHz- 26GHz, RBW= 1MHz, VBW= 10Hz, Sweep time= 200 ms.

EDR Mode
Band Edges Test Data CH-Low

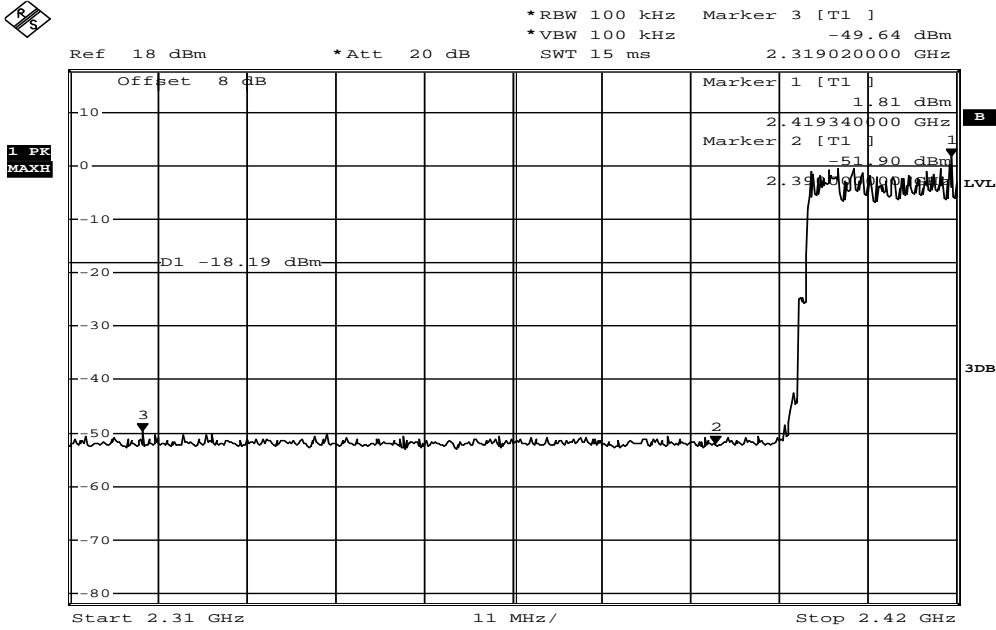

Date: 19.SEP.2011 14:58:42

Band Edges Test Data CH-High

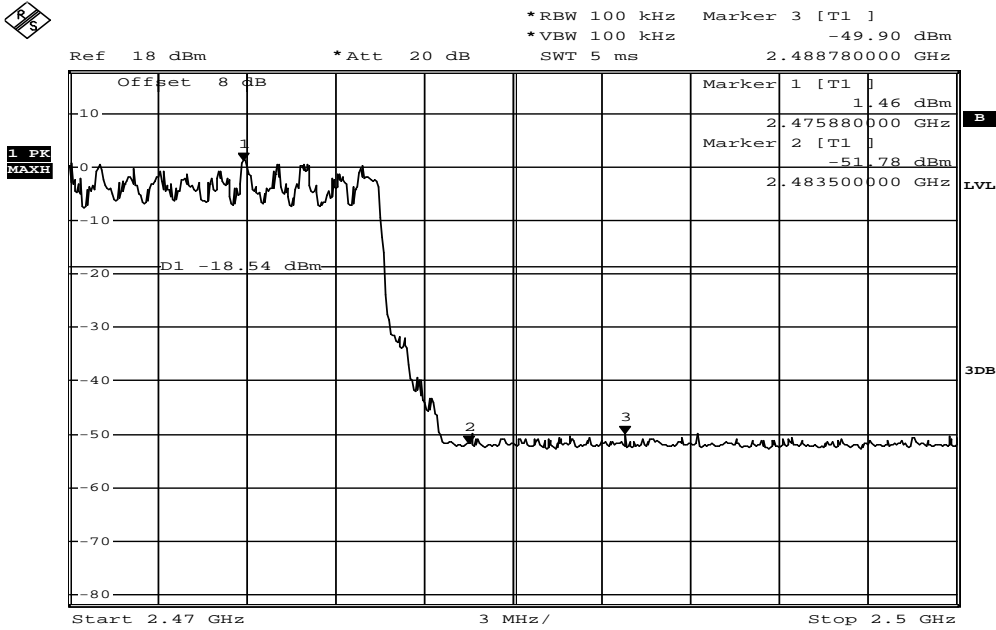

Date: 19.SEP.2011 14:56:34

Radiated Emission (EDR mode):

Operation Mode TX CH Low
Fundamental Frequency 2402 MHz
Temperature 25 °C

Test Date 2011/09/20
Test By Dino
Humidity 60 %

No	Freq MHz	Reading dBuV	Factor dB	Level dBuV/m	Limit dBuV/m	Over Limit dB	Remark	Pol V/H
1	2327.58	35.45	-1.12	34.33	54.00	-19.67	Average	VERTICAL
2	2327.58	55.45	-1.12	54.33	74.00	-19.67	Peak	VERTICAL
3	2390.00	44.86	-1.06	43.80	74.00	-30.20	Peak	VERTICAL
1	2324.97	46.90	-1.13	45.77	74.00	-28.23	Peak	HORIZONTAL
2	2390.00	44.06	-1.06	43.00	74.00	-31.00	Peak	HORIZONTAL

Operation Mode TX CH High
Fundamental Frequency 2480 MHz
Temperature 25 °C

Test Date 2011/09/20
Test By Dino
Humidity 60 %

No	Freq MHz	Reading dBuV	Factor dB	Level dBuV/m	Limit dBuV/m	Over Limit dB	Remark	Pol V/H
1	2483.62	36.76	-0.96	35.80	54.00	-18.20	Average	VERTICAL
2	2483.62	56.77	-0.96	55.81	74.00	-18.19	Peak	VERTICAL
1	2483.50	45.24	-0.96	44.28	74.00	-29.72	Peak	HORIZONTAL
2	2497.08	48.18	-0.95	47.23	74.00	-26.77	Peak	HORIZONTAL

Remark:

- 1 Measuring frequencies from the lowest internal frequency to the 10th of fundamental frequency
- 2 Field strength limits for frequency above 1000MHz are based on average limits. However, Peak mode field strength shall not exceed the average limits specified plus 20dB.
- 3 "F" denotes fundamental frequency; "H" denotes harmonics frequency. "S" denotes spurious frequency.
- 4 Measurement of data within this frequency range shown " - " in the table above means the reading of emissions are attenuated more than 20dB below the permissible limits or the field strength is too small to be measured.
- 5 Spectrum Peak mode IF bandwidth Setting : 1GHz- 26GHz, RBW= 1MHz, Sweep time= 200 ms., the VBW setting was 3 MHz.
- 6 Spectrum AV mode if bandwidth Setting : 1GHz- 26GHz, RBW= 1MHz, VBW= 10Hz, Sweep time= 200 ms.

8. SPURIOUS EMISSION TEST

8.1. Standard Applicable:

According to §15.247(c), all other emissions outside these bands shall not exceed the general radiated emission limits specified in §15.209(a). And according to §15.33(a)(1), for an intentional radiator operates below 10GHz, the frequency range of measurements: to the tenth harmonic of the highest fundamental frequency or to 40GHz, whichever is lower.

According to RSS-Gen §7.2.3 and RSS-210 issue 8,§A2.9, In any 100 kHz bandwidth outside the frequency band in which the spread spectrum or digitally modulated device is operating, the radio frequency power that is produced shall be at least 20 dB below that in the 100 kHz bandwidth within the band that contains the highest level of the desired power, based on either an RF conducted or a radiated measurement, provided the transmitter demonstrates compliance with the peak conducted power limits. If the transmitter complies with the conducted power limits based on the use of RMS averaging over a time interval, as permitted under section A8.4(4), the attenuation required shall be 30 dB instead of 20 dB. Attenuation below the general limits specified in Tables 2 and 3 is not required. In addition, radiated emissions which fall in the restricted bands of Table 1 must also comply with the radiated emission limits specified in Tables 2 and 3.

8.2. Measurement Equipment Used:

8.2.1. Conducted Emission at antenna port:

Refer to section 6.2 for details.

8.2.2. Radiated emission:

Refer to section 7.2 for details.

8.3. Test SET-UP:

8.3.1. Conducted Emission at antenna port:

Refer to section 6.3 for details.

8.3.2. Radiated emission:

Refer to section 7.3 for details.

8.4. Measurement Procedure:

1. The EUT was placed on a turn table which is 0.8m above ground plane.
2. The turn table shall rotate 360 degrees to determine the position of maximum emission level.
3. EUT is set 3m away from the receiving antenna which varied from 1m to 4m to find out the highest emissions.
4. When measurement procedures for electric field radiated emissions above 1 GHz the EUT measurement is to be made “while keeping the antenna in the ‘cone of radiation’ from that area and pointed at the area both in azimuth and elevation, with polarization oriented for maximum response.” is still within the 3dB illumination BW of the measurement antenna.
5. Maximum procedure was performed on the six highest emissions to ensure EUT compliance.
6. And also, each emission was to be maximized by changing the polarization of receiving antenna both horizontal and vertical.
7. Repeat above procedures until all frequency measured were complete.

8.5. Field Strength Calculation

The field strength is calculated by adding the Antenna Factor and Cable Factor and subtracting the Amplifier Gain and Duty Cycle Correction Factor(if any) from the measured reading. The basic equation with a sample calculation is as follows:

$$FS = RA + AF + CL - AG$$

Where	FS = Field Strength	CL = Cable Attenuation Factor (Cable Loss)
	RA = Reading Amplitude	AG = Amplifier Gain
	AF = Antenna Factor	

8.6. Measurement Result:

Note: Refer to next page spectrum analyzer data chart and tabular data sheets.

Conducted Spurious Emission Measurement Result (worst case: BDR Mode)
Ch Low 30MHz – 3GHz

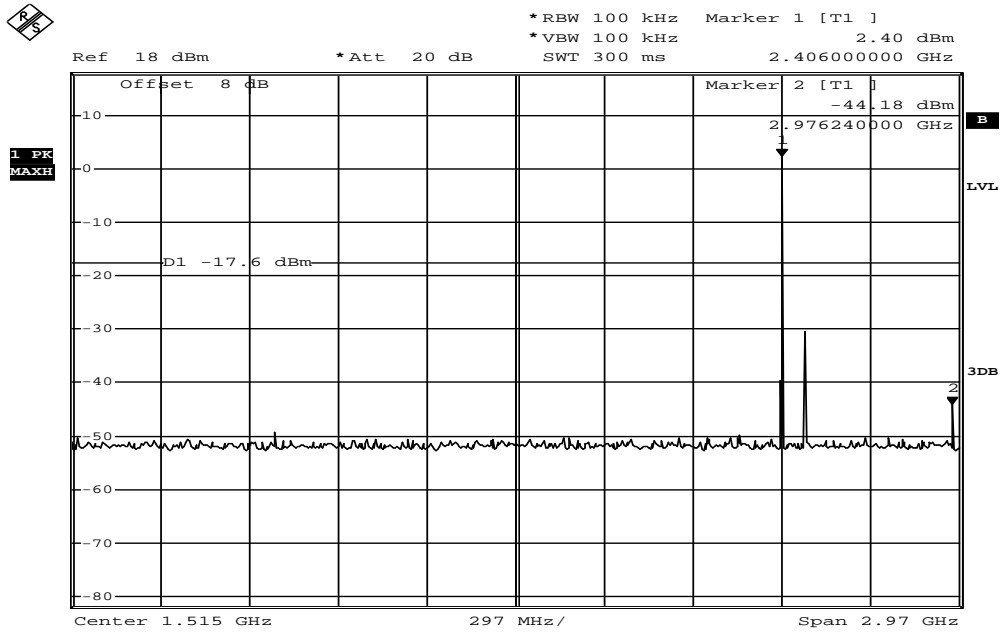

Date: 19.SEP.2011 15:13:42

Ch Low 3GHz – 26.5GHz

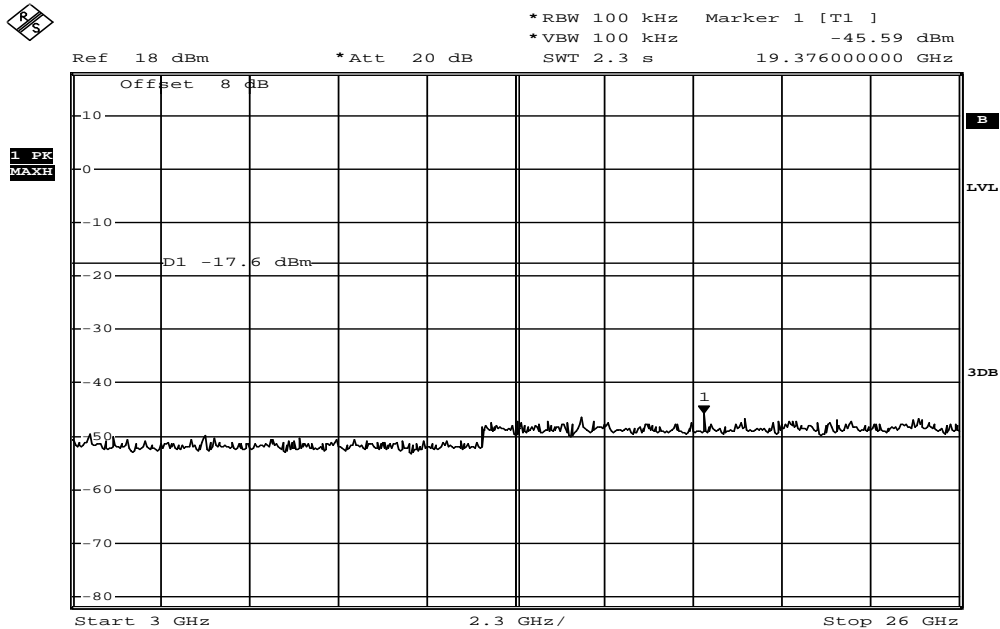

Date: 19.SEP.2011 15:14:03

Ch High 30MHz – 3GHz

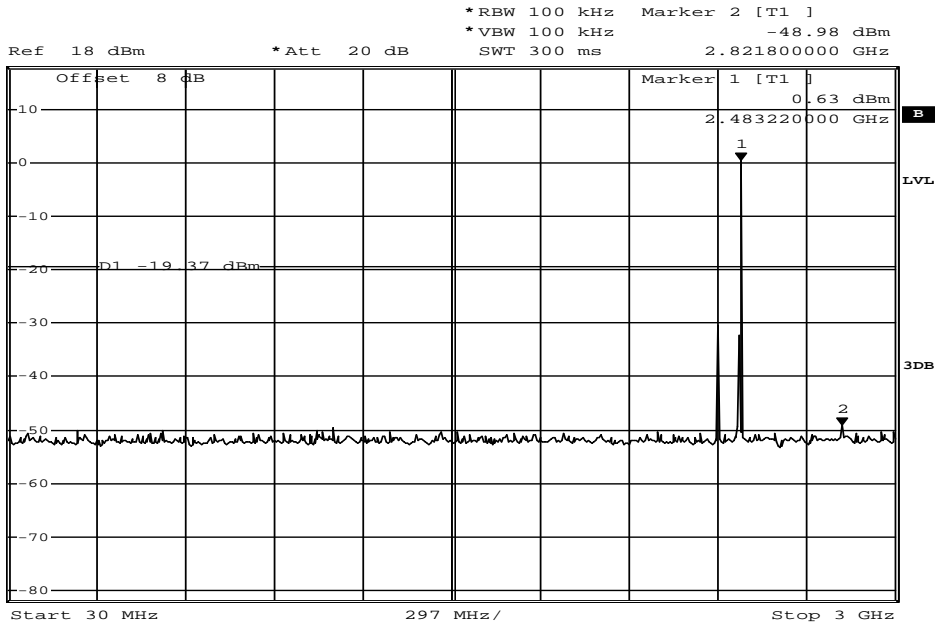

Date: 19.SEP.2011 15:17:31

Ch High 3GHz – 26.5GHz

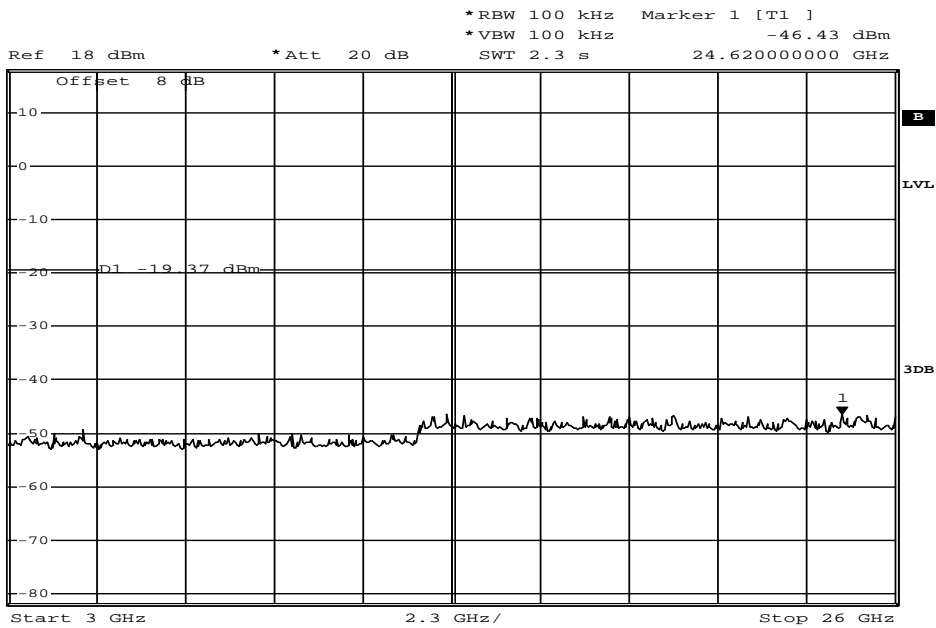

Date: 19.SEP.2011 15:17:51

Radiated Spurious Emission Measurement Result (below 1GHz) (BDR mode)

Operation Mode	TX CH Low	Test Date	2011/09/20
Fundamental Frequency	2402MHz	Test By	Dino
Temperature	25 °C	Humidity	60 %

No	Freq MHz	Reading dBuV	Factor dB	Level dBuV/m	Limit dBuV/m	Over Limit dB	Remark	Pol V/H
1	126.03	55.27	-14.70	40.57	43.50	-2.93	Peak	VERTICAL
2	299.66	56.51	-13.00	43.51	46.00	-2.49	Peak	VERTICAL
3	399.57	51.25	-11.09	40.16	46.00	-5.84	Peak	VERTICAL
4	499.48	51.05	-10.68	40.37	46.00	-5.63	Peak	VERTICAL
5	699.30	51.27	-8.99	42.28	46.00	-3.72	Peak	VERTICAL
6	959.26	48.07	-6.14	41.93	46.00	-4.07	Peak	VERTICAL
1	299.66	55.98	-13.00	42.98	46.00	-3.02	Peak	HORIZONTAL
2	365.62	53.90	-11.56	42.34	46.00	-3.66	Peak	HORIZONTAL
3	499.48	53.10	-10.68	42.42	46.00	-3.58	Peak	HORIZONTAL
4	575.14	51.39	-9.67	41.72	46.00	-4.28	Peak	HORIZONTAL
5	699.30	51.15	-8.99	42.16	46.00	-3.84	Peak	HORIZONTAL
6	960.23	48.31	-6.14	42.17	54.00	-11.83	Peak	HORIZONTAL

Remark:

- 1 No further spurious emissions detected from the lowest internal frequency and 30MHz.
- 2 Measuring frequencies from the lowest internal frequency to the 1GHz.
- 3 Radiated emissions measured in frequency range from 9MHz to 1000MHz were made with an instrument detector setting 9-90KHz/110-490KHz using PK/AV and other Frequency Band using PK/QP
- 4 Measurement result within this frequency range shown “ - ” in the table above means the reading of emissions are attenuated more than 20dB below the permissible limits or the field strength is too small to be measured.
- 5 The IF bandwidth of SPA between 9kHz to 30MHz was 10kHz, VBW= 30kHz; between 30MHz to 1GHz was 100KHz, VBW=300KHz.

Radiated Spurious Emission Measurement Result (below 1GHz)

Operation Mode	TX CH Mid	Test Date	2011/09/20
Fundamental Frequency	2441MHz	Test By	Dino
Temperature	25 °C	Humidity	60 %

No	Freq MHz	Reading dBuV	Factor dB	Level dBuV/m	Limit dBuV/m	Over Limit dB	Remark	Pol V/H
1	99.84	56.46	-16.30	40.16	43.50	-3.34	Peak	VERTICAL
2	149.31	57.00	-16.05	40.95	43.50	-2.55	Peak	VERTICAL
3	350.10	48.17	-11.76	36.41	46.00	-9.59	Peak	VERTICAL
4	499.48	47.10	-10.68	36.42	46.00	-9.58	Peak	VERTICAL
5	699.30	51.78	-8.99	42.79	46.00	-3.21	Peak	VERTICAL
6	959.26	45.98	-6.14	39.84	46.00	-6.16	Peak	VERTICAL
1	140.58	56.61	-15.49	41.12	43.50	-2.38	Peak	HORIZONTAL
2	249.22	52.18	-14.01	38.17	46.00	-7.83	Peak	HORIZONTAL
3	399.57	49.24	-11.09	38.15	46.00	-7.85	Peak	HORIZONTAL
4	575.14	47.87	-9.67	38.20	46.00	-7.80	Peak	HORIZONTAL
5	699.30	47.79	-8.99	38.80	46.00	-7.20	Peak	HORIZONTAL
6	960.23	48.06	-6.14	41.92	54.00	-12.08	Peak	HORIZONTAL

Remark:

- 1 No further spurious emissions detected from the lowest internal frequency and 30MHz.
- 2 Measuring frequencies from the lowest internal frequency to the 1GHz.
- 3 Radiated emissions measured in frequency range from 9MHz to 1000MHz were made with an instrument detector setting 9-90KHz/110-490KHz using PK/AV and other Frequency Band using PK/QP
- 4 Measurement result within this frequency range shown “ - ” in the table above means the reading of emissions are attenuated more than 20dB below the permissible limits or the field strength is too small to be measured.
- 5 The IF bandwidth of SPA between 9kHz to 30MHz was 10kHz, VBW= 30kHz; between 30MHz to 1GHz was 100KHz, VBW=300KHz.

Radiated Spurious Emission Measurement Result (below 1GHz)

Operation Mode	TX CH High	Test Date	2011/09/20
Fundamental Frequency	2480MHz	Test By	Dino
Temperature	25 °C	Humidity	60 %

No	Freq MHz	Reading dBuV	Factor dB	Level dBuV/m	Limit dBuV/m	Over Limit dB	Remark	Pol V/H
1	99.84	54.58	-16.30	38.28	43.50	-5.22	Peak	VERTICAL
2	149.31	56.25	-16.05	40.20	43.50	-3.30	Peak	VERTICAL
3	350.10	50.99	-11.76	39.23	46.00	-6.77	Peak	VERTICAL
4	499.48	46.90	-10.68	36.22	46.00	-9.78	Peak	VERTICAL
5	699.30	50.91	-8.99	41.92	46.00	-4.08	Peak	VERTICAL
6	959.26	46.68	-6.14	40.54	46.00	-5.46	Peak	VERTICAL
1	140.58	56.15	-15.49	40.66	43.50	-2.84	Peak	HORIZONTAL
2	249.22	52.11	-14.01	38.10	46.00	-7.90	Peak	HORIZONTAL
3	377.26	53.21	-11.40	41.81	46.00	-4.19	Peak	HORIZONTAL
4	576.11	48.49	-9.67	38.82	46.00	-7.18	Peak	HORIZONTAL
5	699.30	48.27	-8.99	39.28	46.00	-6.72	Peak	HORIZONTAL
6	959.26	48.73	-6.14	42.59	46.00	-3.41	Peak	HORIZONTAL

Remark:

- 1 No further spurious emissions detected from the lowest internal frequency and 30MHz.
- 2 Measuring frequencies from the lowest internal frequency to the 1GHz.
- 3 Radiated emissions measured in frequency range from 9MHz to 1000MHz were made with an instrument detector setting 9-90KHz/110-490KHz using PK/AV and other Frequency Band using PK/QP
- 4 Measurement result within this frequency range shown “ - ” in the table above means the reading of emissions are attenuated more than 20dB below the permissible limits or the field strength is too small to be measured.
- 5 The IF bandwidth of SPA between 9kHz to 30MHz was 10kHz, VBW= 30kHz; between 30MHz to 1GHz was 100KHz, VBW=300KHz.

Radiated Spurious Emission Measurement Result (above 1GHz)

Operation Mode	TX CH Low	Test Date	2011/09/20
Fundamental Frequency	2402 MHz	Test By	Dino
Temperature	25 °C	Humidity	60 %

No	Freq MHz	Reading dBuV	Factor dB	Level dBuV/m	Limit dBuV/m	Over Limit dB	Remark	Pol V/H
1	1329.00	49.18	-6.78	42.40	74.00	-31.60	Peak	VERTICAL
2	1994.00	52.27	-1.53	50.74	74.00	-23.26	Peak	VERTICAL
3	3989.00	38.68	6.18	44.86	74.00	-29.14	Peak	VERTICAL
4	4804.00	41.22	10.01	51.23	74.00	-22.77	Peak	VERTICAL
5	7206.00	---						VERTICAL
6	9608.00	---						VERTICAL
7	12010.00	---						VERTICAL
1	1196.00	43.90	-7.54	36.36	74.00	-37.64	Peak	HORIZONTAL
2	4874.00	33.42	10.30	43.72	74.00	-30.28	Peak	HORIZONTAL
3	7206.00	---						HORIZONTAL
4	9608.00	---						HORIZONTAL
5	12010.00	---						HORIZONTAL

Remark:

- 1 Measuring frequencies from the lowest internal frequency to the 10th of fundamental frequency
- 2 Field strength limits for frequency above 1000MHz are based on average limits. However, Peak mode field strength shall not exceed the average limits specified plus 20dB.
- 3 Measurement of data within this frequency range shown “ - ” in the table above means the reading of emissions are attenuated more than 20dB below the permissible limits or the field strength is too small to be measured.
- 4 Spectrum Peak mode IF bandwidth Setting : 1GHz- 26GHz, RBW= 1MHz, Sweep time= 200 ms., the VBW setting was 3 MHz.
- 5 Spectrum AV mode if bandwidth Setting : 1GHz- 26GHz, RBW= 1MHz, VBW= 10Hz, Sweep time= 200 ms.

Radiated Spurious Emission Measurement Result (above 1GHz)

Operation Mode	TX CH Mid	Test Date	2011/09/20
Fundamental Frequency	2441 MHz	Test By	Dino
Temperature	25 °C	Humidity	60 %

No	Freq MHz	Reading dBuV	Factor dB	Level dBuV/m	Limit dBuV/m	Over Limit dB	Remark	Pol V/H
1	1329.00	50.91	-6.78	44.13	74.00	-29.87	Peak	VERTICAL
2	1987.00	52.70	-1.59	51.11	74.00	-22.89	Peak	VERTICAL
3	4882.00	38.78	10.33	49.11	54.00	-4.89	Average	VERTICAL
4	4882.00	58.78	10.33	69.11	74.00	-4.89	Peak	VERTICAL
5	7323.00	---						VERTICAL
6	9764.00	---						VERTICAL
7	12205.00	---						VERTICAL
1	1329.00	47.86	-6.78	41.08	74.00	-32.92	Peak	HORIZONTAL
2	1994.00	42.30	-1.53	40.77	74.00	-33.23	Peak	HORIZONTAL
3	4882.00	34.13	10.33	44.46	54.00	-9.54	Average	HORIZONTAL
4	4882.00	54.13	10.33	64.46	74.00	-9.54	Peak	HORIZONTAL
5	7323.00	---						HORIZONTAL
6	9764.00	---						HORIZONTAL
7	12205.00	---						HORIZONTAL

Remark:

- 1 Measuring frequencies from the lowest internal frequency to the 10th of fundamental frequency
- 2 Field strength limits for frequency above 1000MHz are based on average limits. However, Peak mode field strength shall not exceed the average limits specified plus 20dB.
- 3 Measurement of data within this frequency range shown “ - ” in the table above means the reading of emissions are attenuated more than 20dB below the permissible limits or the field strength is too small to be measured.
- 4 Spectrum Peak mode IF bandwidth Setting : 1GHz- 26GHz, RBW= 1MHz, Sweep time= 200 ms., the VBW setting was 3 MHz.
- 5 Spectrum AV mode if bandwidth Setting : 1GHz- 26GHz, RBW= 1MHz, VBW= 10Hz, Sweep time= 200 ms.

Radiated Spurious Emission Measurement Result (above 1GHz)

Operation Mode	TX CH High	Test Date	2011/09/20
Fundamental Frequency	2480 MHz	Test By	Dino
Temperature	25 °C	Humidity	60 %

No	Freq MHz	Reading dBuV	Factor dB	Level dBuV/m	Limit dBuV/m	Over Limit dB	Remark	Pol V/H
1	1602.00	45.13	-4.93	40.20	74.00	-33.80	Peak	VERTICAL
2	1987.00	47.88	-1.59	46.29	74.00	-27.71	Peak	VERTICAL
3	4960.00	40.88	10.66	51.54	54.00	-2.46	Average	VERTICAL
4	4960.00	60.88	10.66	71.54	74.00	-2.46	Peak	VERTICAL
5	7440.00	---						VERTICAL
6	9920.00	---						VERTICAL
7	12400.00	---						VERTICAL
1	1322.00	48.53	-6.82	41.71	74.00	-32.29	Peak	HORIZONTAL
2	1994.00	45.41	-1.53	43.88	74.00	-30.12	Peak	HORIZONTAL
3	4960.00	36.79	10.66	47.45	54.00	-6.55	Average	HORIZONTAL
4	4960.00	56.79	10.66	67.45	74.00	-6.55	Peak	HORIZONTAL
5	7440.00	---						HORIZONTAL
6	9920.00	---						HORIZONTAL
7	12400.00	---						HORIZONTAL

Remark:

- 1 Measuring frequencies from the lowest internal frequency to the 10th of fundamental frequency
- 2 Field strength limits for frequency above 1000MHz are based on average limits. However, Peak mode field strength shall not exceed the average limits specified plus 20dB.
- 3 Measurement of data within this frequency range shown “ - ” in the table above means the reading of emissions are attenuated more than 20dB below the permissible limits or the field strength is too small to be measured.
- 4 Spectrum Peak mode IF bandwidth Setting : 1GHz- 26GHz, RBW= 1MHz, Sweep time= 200 ms., the VBW setting was 3 MHz.
- 5 Spectrum AV mode if bandwidth Setting : 1GHz- 26GHz, RBW= 1MHz, VBW= 10Hz, Sweep time= 200 ms.

Radiated Spurious Emission Measurement Result (below 1GHz)

Operation Mode	RX CH Low	Test Date	2011/09/20
Fundamental Frequency	2402MHz	Test By	Dino
Temperature	25 °C	Humidity	60 %

No	Freq MHz	Reading dBuV	Factor dB	Level dBuV/m	Limit dBuV/m	Over Limit dB	Remark	Pol V/H
1	95.96	55.32	-16.97	38.35	43.50	-5.15	Peak	VERTICAL
2	149.31	56.27	-16.05	40.22	43.50	-3.28	Peak	VERTICAL
3	299.66	46.39	-13.00	33.39	46.00	-12.61	Peak	VERTICAL
4	575.14	42.30	-9.67	32.63	46.00	-13.37	Peak	VERTICAL
5	863.23	38.01	-7.25	30.76	46.00	-15.24	Peak	VERTICAL
6	959.26	46.88	-6.14	40.74	46.00	-5.26	Peak	VERTICAL
1	139.61	56.52	-15.41	41.11	43.50	-2.39	Peak	HORIZONTAL
2	299.66	51.68	-13.00	38.68	46.00	-7.32	Peak	HORIZONTAL
3	399.57	50.01	-11.09	38.92	46.00	-7.08	Peak	HORIZONTAL
4	576.11	49.82	-9.67	40.15	46.00	-5.85	Peak	HORIZONTAL
5	699.30	44.41	-8.99	35.42	46.00	-10.58	Peak	HORIZONTAL
6	960.23	49.02	-6.14	42.88	54.00	-11.12	Peak	HORIZONTAL

Remark:

- 1 No further spurious emissions detected from the lowest internal frequency and 30MHz.
- 2 Measuring frequencies from the lowest internal frequency to the 1GHz.
- 3 Radiated emissions measured in frequency range from 9MHz to 1000MHz were made with an instrument detector setting 9-90KHz/110-490KHz using PK/AV and other Frequency Band using PK/QP
- 4 Measurement result within this frequency range shown “ - ” in the table above means the reading of emissions are attenuated more than 20dB below the permissible limits or the field strength is too small to be measured.
- 5 The IF bandwidth of SPA between 9kHz to 30MHz was 10kHz, VBW= 30kHz; between 30MHz to 1GHz was 100KHz, VBW=300KHz.

Radiated Spurious Emission Measurement Result (below 1GHz)

Operation Mode	RX CH Mid	Test Date	2011/09/20
Fundamental Frequency	2441MHz	Test By	Dino
Temperature	25°C	Humidity	60 %

No	Freq MHz	Reading dBuV	Factor dB	Level dBuV/m	Limit dBuV/m	Over Limit dB	Remark	Pol V/H
1	99.84	55.30	-16.30	39.00	43.50	-4.50	Peak	VERTICAL
2	149.31	55.31	-16.05	39.26	43.50	-4.24	Peak	VERTICAL
3	299.66	46.68	-13.00	33.68	46.00	-12.32	Peak	VERTICAL
4	575.14	42.69	-9.67	33.02	46.00	-12.98	Peak	VERTICAL
5	699.30	39.08	-8.99	30.09	46.00	-15.91	Peak	VERTICAL
6	959.26	46.47	-6.14	40.33	46.00	-5.67	Peak	VERTICAL
1	140.58	56.43	-15.49	40.94	43.50	-2.56	Peak	HORIZONTAL
2	299.66	51.84	-13.00	38.84	46.00	-7.16	Peak	HORIZONTAL
3	399.57	49.71	-11.09	38.62	46.00	-7.38	Peak	HORIZONTAL
4	575.14	50.12	-9.67	40.45	46.00	-5.55	Peak	HORIZONTAL
5	863.23	43.75	-7.25	36.50	46.00	-9.50	Peak	HORIZONTAL
6	959.26	49.09	-6.14	42.95	46.00	-3.05	Peak	HORIZONTAL

Remark:

- 1 No further spurious emissions detected from the lowest internal frequency and 30MHz.
- 2 Measuring frequencies from the lowest internal frequency to the 1GHz.
- 3 Radiated emissions measured in frequency range from 9MHz to 1000MHz were made with an instrument detector setting 9-90KHz/110-490KHz using PK/AV and other Frequency Band using PK/QP
- 4 Measurement result within this frequency range shown “ - ” in the table above means the reading of emissions are attenuated more than 20dB below the permissible limits or the field strength is too small to be measured.
- 5 The IF bandwidth of SPA between 9kHz to 30MHz was 10kHz, VBW= 30kHz; between 30MHz to 1GHz was 100KHz, VBW=300KHz.

Radiated Spurious Emission Measurement Result (below 1GHz)

Operation Mode	RX CH High	Test Date	2011/09/20
Fundamental Frequency	2480MHz	Test By	Dino
Temperature	25 °C	Humidity	65%

No	Freq MHz	Reading dBuV	Factor dB	Level dBuV/m	Limit dBuV/m	Over Limit dB	Remark	Pol V/H
1	95.96	55.41	-16.97	38.44	43.50	-5.06	Peak	VERTICAL
2	149.31	56.38	-16.05	40.33	43.50	-3.17	Peak	VERTICAL
3	199.75	53.31	-16.69	36.62	43.50	-6.88	Peak	VERTICAL
4	299.66	46.21	-13.00	33.21	46.00	-12.79	Peak	VERTICAL
5	575.14	40.86	-9.67	31.19	46.00	-14.81	Peak	VERTICAL
6	959.26	47.00	-6.14	40.86	46.00	-5.14	Peak	VERTICAL
1	149.31	57.20	-16.05	41.15	43.50	-2.35	Peak	HORIZONTAL
2	299.66	52.39	-13.00	39.39	46.00	-6.61	Peak	HORIZONTAL
3	399.57	49.56	-11.09	38.47	46.00	-7.53	Peak	HORIZONTAL
4	575.14	50.90	-9.67	41.23	46.00	-4.77	Peak	HORIZONTAL
5	699.30	44.64	-8.99	35.65	46.00	-10.35	Peak	HORIZONTAL
6	959.26	48.36	-6.14	42.22	46.00	-3.78	Peak	HORIZONTAL

Remark:

- 1 No further spurious emissions detected from the lowest internal frequency and 30MHz.
- 2 Measuring frequencies from the lowest internal frequency to the 1GHz.
- 3 Radiated emissions measured in frequency range from 9MHz to 1000MHz were made with an instrument detector setting 9-90KHz/110-490KHz using PK/AV and other Frequency Band using PK/QP
- 4 Measurement result within this frequency range shown “ - ” in the table above means the reading of emissions are attenuated more than 20dB below the permissible limits or the field strength is too small to be measured.
- 5 The IF bandwidth of SPA between 9kHz to 30MHz was 10kHz, VBW= 30kHz; between 30MHz to 1GHz was 100KHz, VBW=300KHz.

Radiated Spurious Emission Measurement Result (above 1GHz)

Operation Mode	RX CH Low	Test Date	2011/09/20
Fundamental Frequency	2402 MHz	Test By	Dino
Temperature	25°C	Humidity	60 %

No	Freq MHz	Reading dBuV	Factor dB	Level dBuV/m	Limit dBuV/m	Over Limit dB	Remark	Pol V/H
1	1987.00	42.24	-1.59	40.65	74.00	-33.35	Peak	VERTICAL
2	4804.00	---						VERTICAL
3	7206.00	---						VERTICAL
4	9608.00	---						VERTICAL
5	12010.00	---						VERTICAL
1	4804.00	33.73	7.17	40.90	74.00	-33.10	Peak	HORIZONTAL
2	7206.00	---						HORIZONTAL
3	9608.00	---						HORIZONTAL
4	12010.00	---						HORIZONTAL

Remark:

- 1 Measuring frequencies from the lowest internal frequency to the 10th of fundamental frequency
- 2 Field strength limits for frequency above 1000MHz are based on average limits. However, Peak mode field strength shall not exceed the average limits specified plus 20dB.
- 3 Measurement of data within this frequency range shown “ - ” in the table above means the reading of emissions are attenuated more than 20dB below the permissible limits or the field strength is too small to be measured.
- 4 Spectrum Peak mode IF bandwidth Setting : 1GHz- 26GHz, RBW= 1MHz, Sweep time= 200 ms., the VBW setting was 3 MHz.
- 5 Spectrum AV mode if bandwidth Setting : 1GHz- 26GHz, RBW= 1MHz, VBW= 10Hz, Sweep time= 200 ms.

Radiated Spurious Emission Measurement Result (above 1GHz)

Operation Mode	RX CH Mid	Test Date	2011/09/20
Fundamental Frequency	2441 MHz	Test By	Dino
Temperature	25 °C	Humidity	60 %

No	Freq MHz	Reading dBuV	Factor dB	Level dBuV/m	Limit dBuV/m	Over Limit dB	Remark	Pol V/H
1	1987.00	40.41	-1.59	38.82	74.00	-35.18	Peak	VERTICAL
2	4884.00	32.60	10.30	42.90	74.00	-31.10	Peak	VERTICAL
3	7323.00	---						VERTICAL
4	9764.00	---						VERTICAL
5	12205.00	---						VERTICAL
1	1623.00	40.76	-4.74	36.02	74.00	-37.98	Peak	HORIZONTAL
2	4884.00	---						HORIZONTAL
3	7323.00	---						HORIZONTAL
4	9764.00	---						HORIZONTAL
5	12205.00	---						HORIZONTAL

Remark:

- 1 Measuring frequencies from the lowest internal frequency to the 10th of fundamental frequency
- 2 Field strength limits for frequency above 1000MHz are based on average limits. However, Peak mode field strength shall not exceed the average limits specified plus 20dB.
- 3 Measurement of data within this frequency range shown “ - ” in the table above means the reading of emissions are attenuated more than 20dB below the permissible limits or the field strength is too small to be measured.
- 4 Spectrum Peak mode IF bandwidth Setting : 1GHz- 26GHz, RBW= 1MHz, Sweep time= 200 ms., the VBW setting was 3 MHz.
- 5 Spectrum AV mode if bandwidth Setting : 1GHz- 26GHz, RBW= 1MHz, VBW= 10Hz, Sweep time= 200 ms.

Radiated Spurious Emission Measurement Result (above 1GHz)

Operation Mode	RX CH High	Test Date	2011/09/20
Fundamental Frequency	2480 MHz	Test By	Dino
Temperature	25 °C	Humidity	60 %

No	Freq MHz	Reading dBuV	Factor dB	Level dBuV/m	Limit dBuV/m	Over Limit dB	Remark	Pol V/H
1	1994.00	38.81	-1.53	37.28	74.00	-36.72	Peak	VERTICAL
2	4960.00	---						VERTICAL
3	7440.00	---						VERTICAL
4	9920.00	---						VERTICAL
5	12400.00	---						VERTICAL
1	4325.00	34.28	7.86	42.14	74.00	-31.86	Peak	HORIZONTAL
2	4960.00	33.42	10.30	43.72	74.00	-30.28	Peak	HORIZONTAL
3	7440.00	---						HORIZONTAL
4	9920.00	---						HORIZONTAL
5	12400.00	---						HORIZONTAL

Remark:

- 1 Measuring frequencies from the lowest internal frequency to the 10th of fundamental frequency
- 2 Field strength limits for frequency above 1000MHz are based on average limits. However, Peak mode field strength shall not exceed the average limits specified plus 20dB.
- 3 Measurement of data within this frequency range shown “ - ” in the table above means the reading of emissions are attenuated more than 20dB below the permissible limits or the field strength is too small to be measured.
- 4 Spectrum Peak mode IF bandwidth Setting : 1GHz- 26GHz, RBW= 1MHz, Sweep time= 200 ms., the VBW setting was 3 MHz.
- 5 Spectrum AV mode if bandwidth Setting : 1GHz- 26GHz, RBW= 1MHz, VBW= 10Hz, Sweep time= 200 ms.

9. FREQUENCY SEPARATION

9.1. Standard Applicable:

According to §15.247(a)(1), Frequency hopping systems shall have hopping channel carrier frequencies separated by minimum of 25KHz or the 20dB bandwidth of the hopping channel, whichever is greater.

According to RSS 210 issue 6, A8.1(b), frequency hopping systems operating in the 2400-2483.5 MHz band may have hopping channel carrier frequencies that are separated by 25 kHz or two-thirds of the 20 dB bandwidth of the hopping channel, whichever is greater.

9.2. Measurement Equipment Used:

Refer to section 6.2 for details.

9.3. Test Set-up:

Refer to section 6.3 for details.

9.4. Measurement Procedure:

1. Place the EUT on the table and set it in transmitting mode.
2. Remove the antenna from the EUT and then connect a low loss RF cable from the antenna port to the spectrum analyzer.
3. Set center frequency of spectrum analyzer = middle of hopping channel .
4. Set the spectrum analyzer as RBW,VBW=100KHz, Adjust Span to 3.0 MHz, Sweep = auto.
5. Max hold. Mark 3 Peaks of hopping channel and record the 3 peaks frequency.

9.5. Measurement Result:

Channel separation (MHz)	Limit	Result
1	$\geq 25\text{KHz}$ or 2/3 times 20dB bandwidth	PASS

Note: Refer to next page for plots.

Frequency Separation Test Data

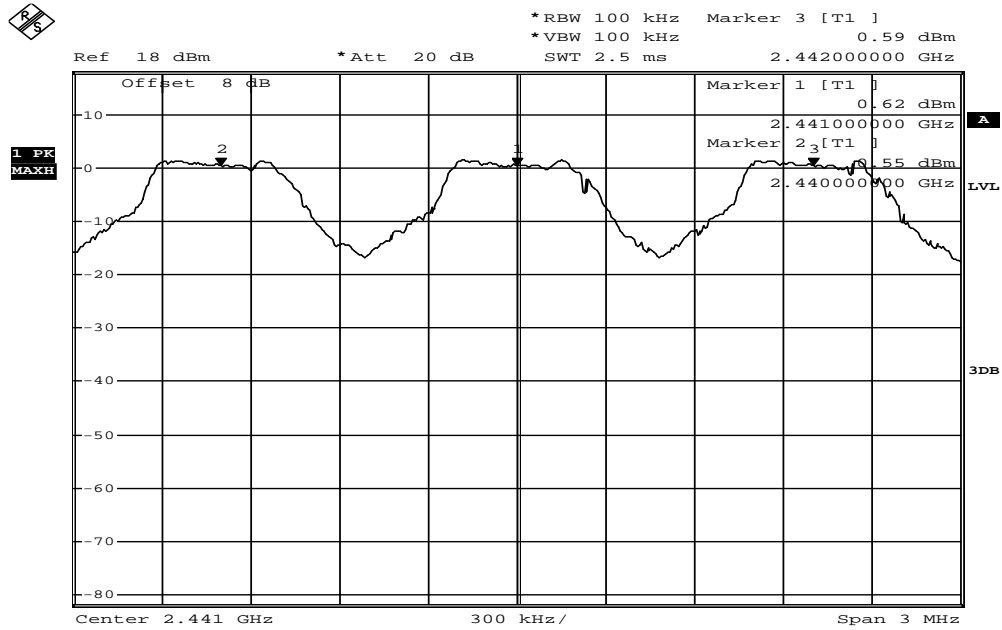

Date: 19.SEP.2011 18:26:43

10. NUMBER OF HOPPING FREQUENCY

10.1. Standard Applicable:

According to §15.247(a)(1)(iii), Frequency hopping systems operating in the 2400MHz-2483.5 MHz bands shall use at least 15 hopping frequencies.

According to RSS-210 issue 8, §A8.1(d), For frequency hopping systems operating in the 2400-2483.5 MHz band employing at least 75 hopping channels, the maximum conducted output power shall not exceed 1 W. For all other frequency hopping systems, the maximum peak conducted output power shall not exceed 0.125 W.

10.2. Measurement Equipment Used:

Refer to section 6.2 for details.

10.3. Test Set-up:

Refer to section 6.3 for details.

10.4. Measurement Procedure:

1. Place the EUT on the table and set it in transmitting mode.
2. Remove the antenna from the EUT and then connect a low loss RF cable from the antenna port to the spectrum analyzer.
3. Set spectrum analyzer Start=2400MHz, Stop = 2441MHz and Start=2441MHz, Stop = 2483.5MHz, Sweep = auto.
4. Set the spectrum analyzer as RBW=300KHz, VBW=1MHz
5. Max hold, view and count how many channel in the band.

10.5. Measurement Result:

Note: Refer to next page for plots.

Channel Number
2.4 GHz – 2.441GHz

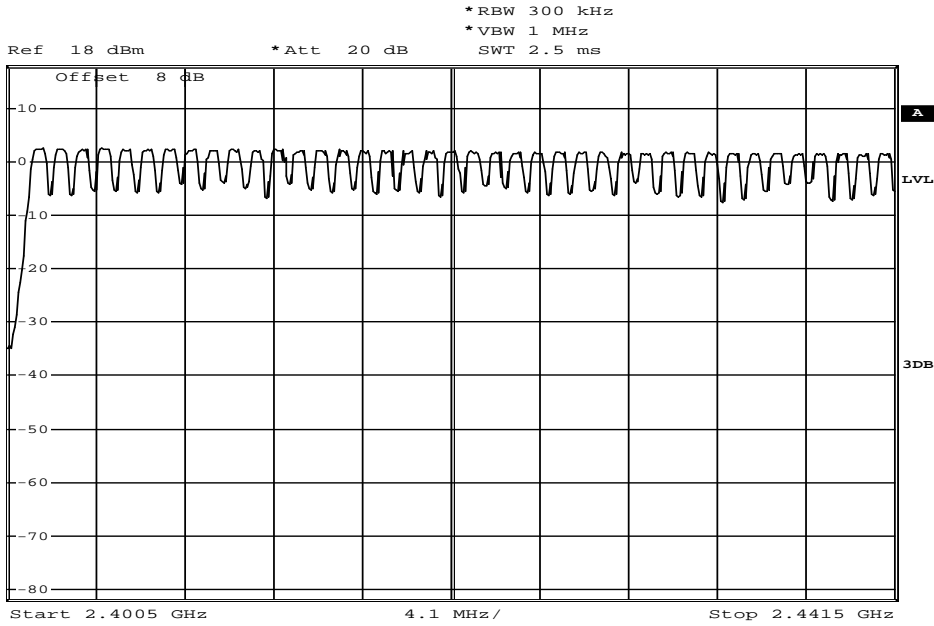

Date: 19.SEP.2011 18:32:46

2.441 GHz – 2.4835GHz

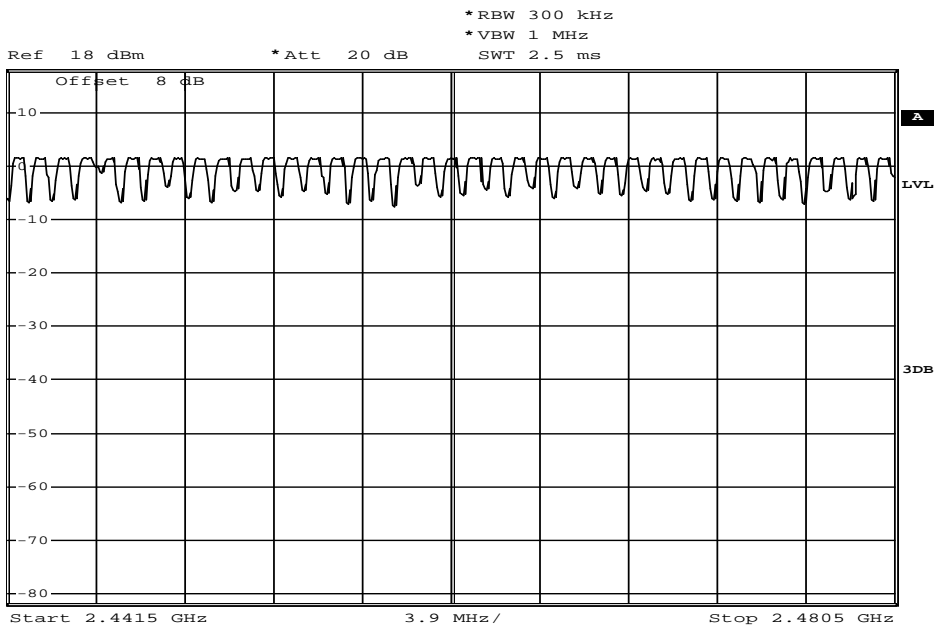

Date: 19.SEP.2011 18:41:37

11. TIME OF OCCUPANCY (DWELL TIME)

11.1. Standard Applicable:

According to §15.247(a)(1)(iii), Frequency hopping systems operating in the 2400MHz-2483.5 MHz. The average time of occupancy on any frequency shall not greater than 0.4 s within period of 0.4 seconds multiplied by the number of hopping channel employed.

According to RSS-210 issue 8, §A8.1(d), Frequency hopping systems operating in the 2400-2483.5 MHz band shall use at least 15 hopping channels. The average time of occupancy on any channel shall not be greater than 0.4 seconds within a period of 0.4 seconds multiplied by the number of hopping channels employed. Transmissions on particular hopping frequencies may be avoided or suppressed provided that a minimum of 15 hopping channels are used.

11.2. Measurement Equipment Used:

Refer to section 6.2 for details.

11.3. Test Set-up:

Refer to section 6.3 for details.

11.4. Measurement Procedure:

1. Place the EUT on the table and set it in transmitting mode.
2. Remove the antenna from the EUT and then connect a low loss RF cable from the antenna port to the spectrum analyzer.
3. Set center frequency of spectrum analyzer = operating frequency.
4. Set the spectrum analyzer as RBW / VBW = 1MHz, Span = 0Hz , Adjust Sweep = 2.5ms.
5. Repeat above procedures until all frequency measured were complete.

11.5. Measurement Result:

A period time = 0.4 (ms) * 79 = 31.6 (s)

CH Low DH1 time slot = 0.390 (ms) * (1600/1/79) * 31.6 = 249.60 (ms)

DH3 time slot = 1.656 (ms) * (1600/4/79) * 31.6 = 353.28 (ms)

DH5 time slot = 2.914 (ms) * (1600/5/79) * 31.6 = 372.99 (ms)

CH Mid DH1 time slot = 0.390 (ms) * (1600/1/79) * 31.6 = 249.60 (ms)

DH3 time slot = 1.656 (ms) * (1600/4/79) * 31.6 = 353.28 (ms)

DH5 time slot = 2.914 (ms) * (1600/5/79) * 31.6 = 372.99 (ms)

CH High DH1 time slot = 0.390 (ms) * (1600/1/79) * 31.6 = 249.60 (ms)

DH3 time slot = 1.656 (ms) * (1600/4/79) * 31.6 = 353.28 (ms)

DH5 time slot = 2.914 (ms) * (1600/5/79) * 31.6 = 372.99 (ms)

Note: Refer to next page for plots.

CH-Low
DH1

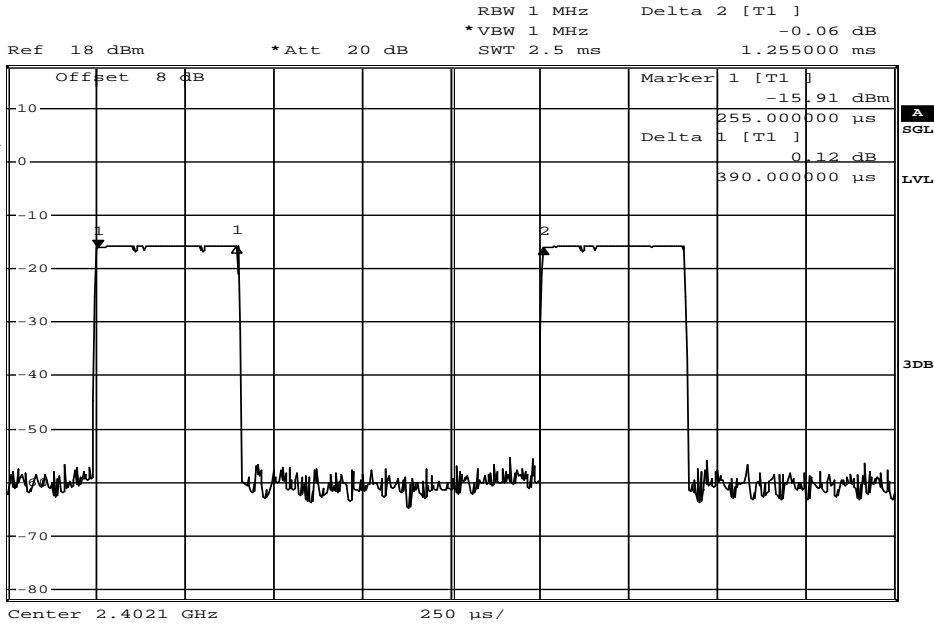

Date: 20.SEP.2011 15:50:39

DH3

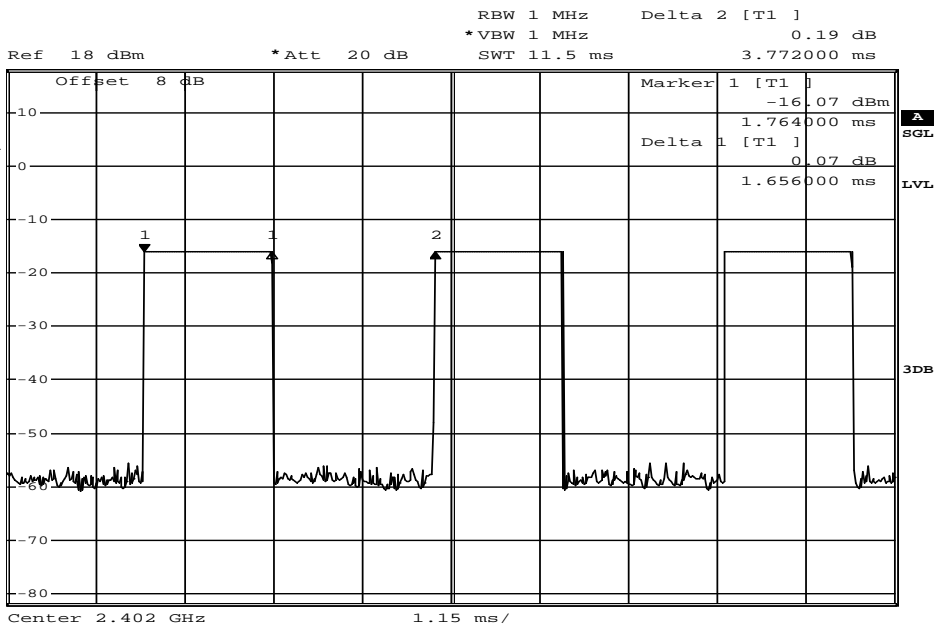

Date: 20.SEP.2011 16:19:30

DH5

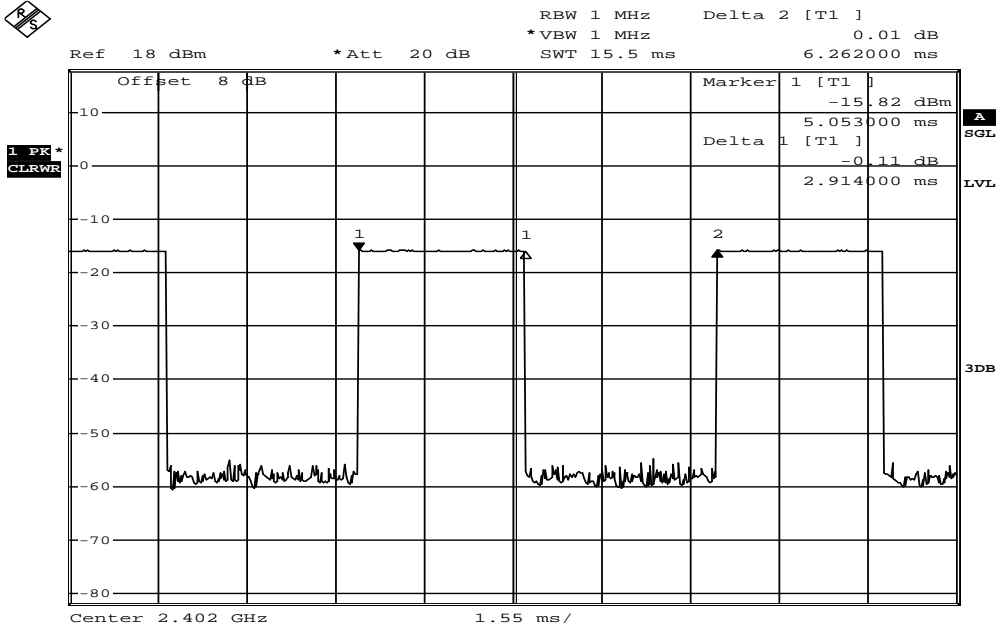

Date: 20.SEP.2011 16:11:34

CH-Mid

DH1

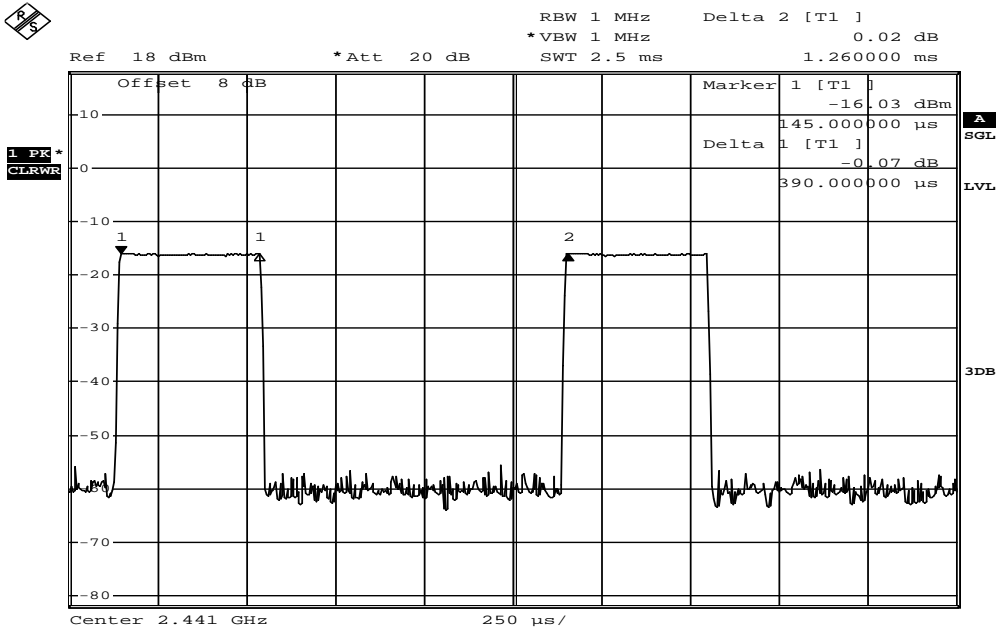

Date: 20.SEP.2011 15:51:31

DH3

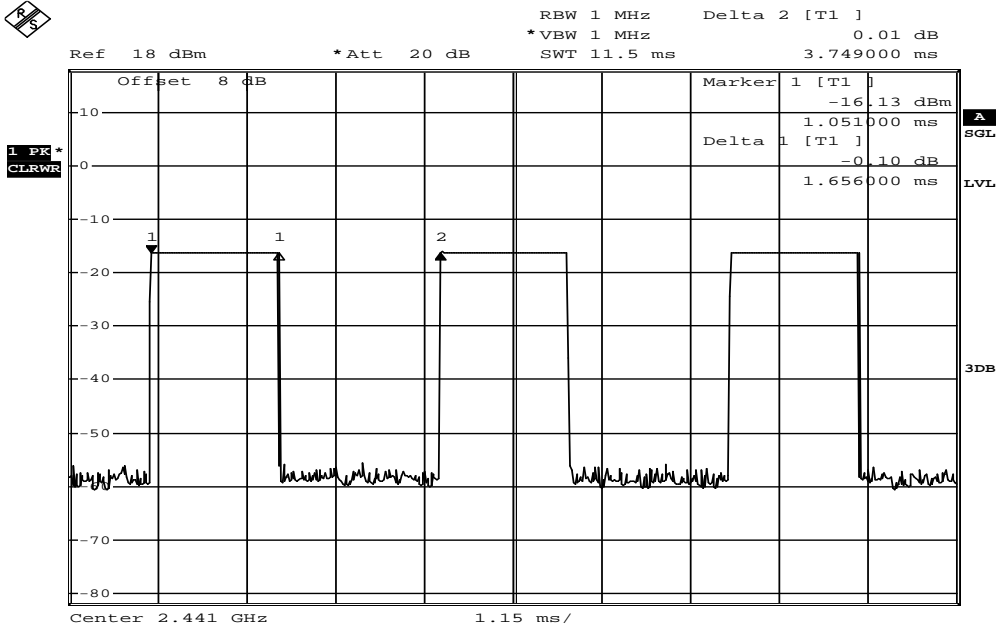

Date: 20.SEP.2011 16:20:06

DH5

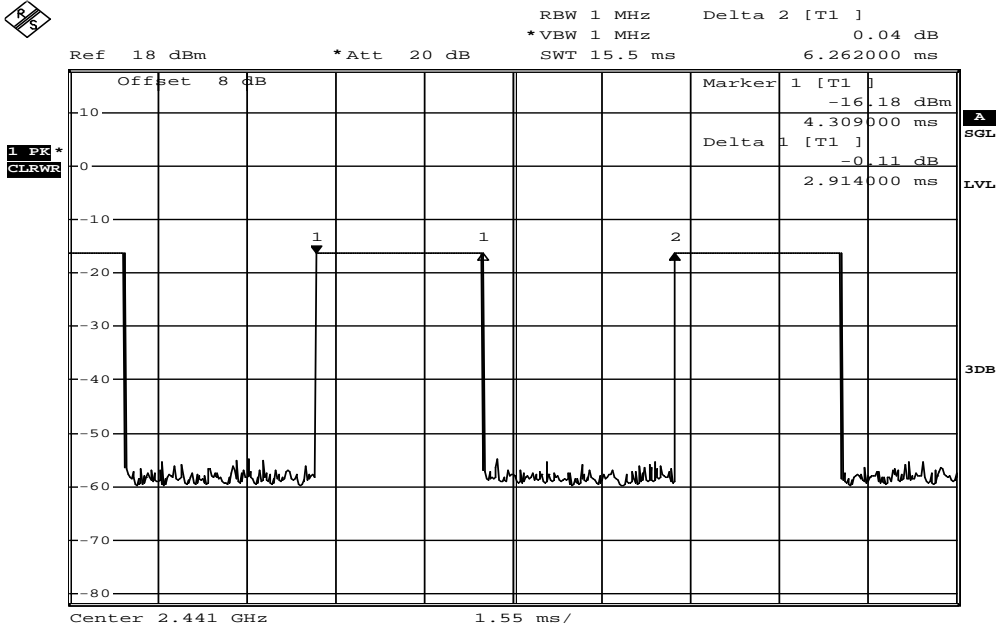

Date: 20.SEP.2011 16:10:59

**CH-High
 DH1**

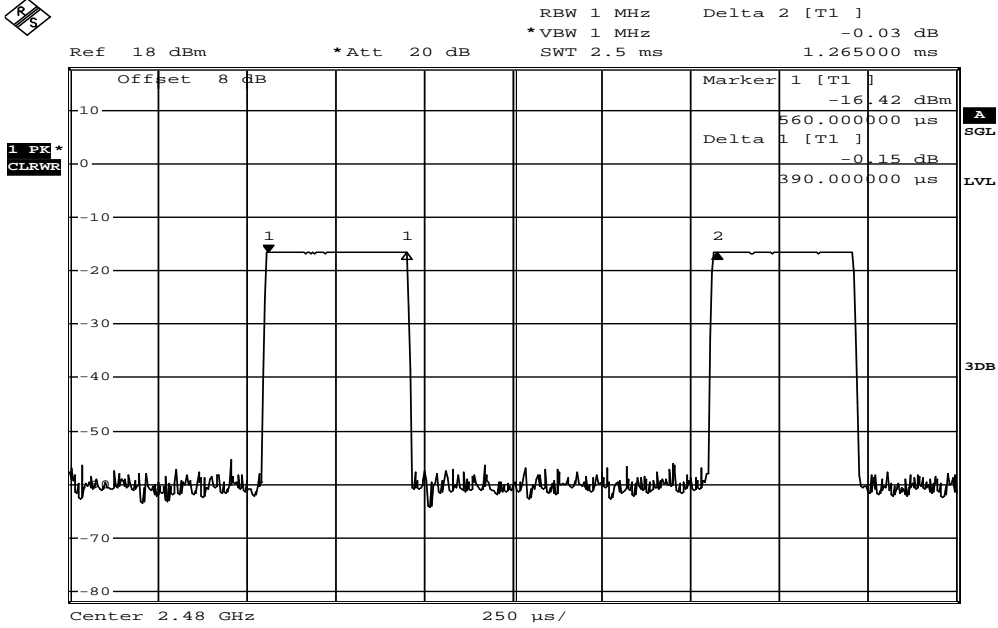

Date: 20.SEP.2011 15:52:12

DH3

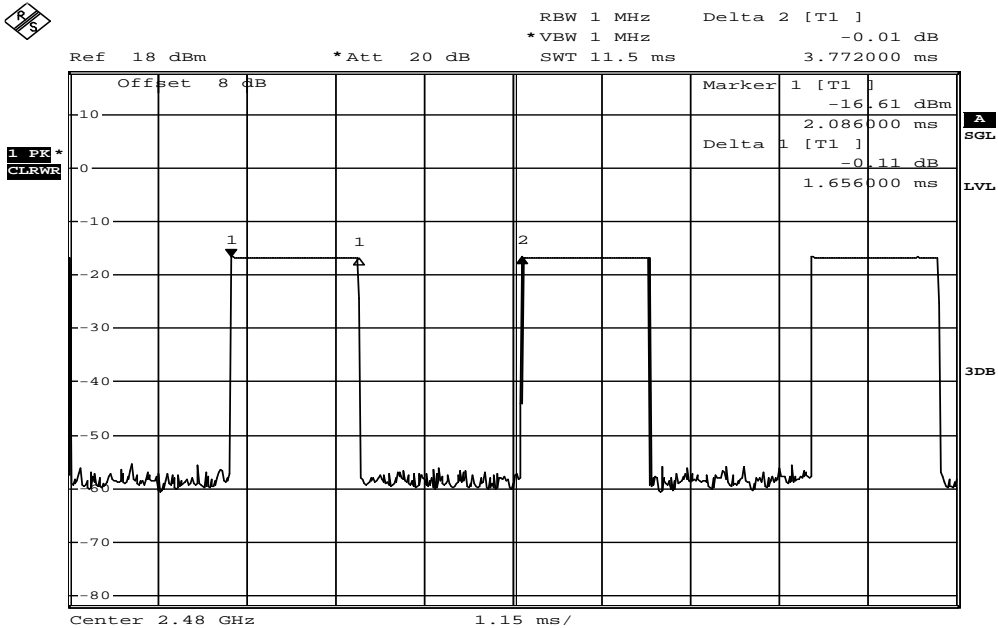

Date: 20.SEP.2011 16:20:48

DH5

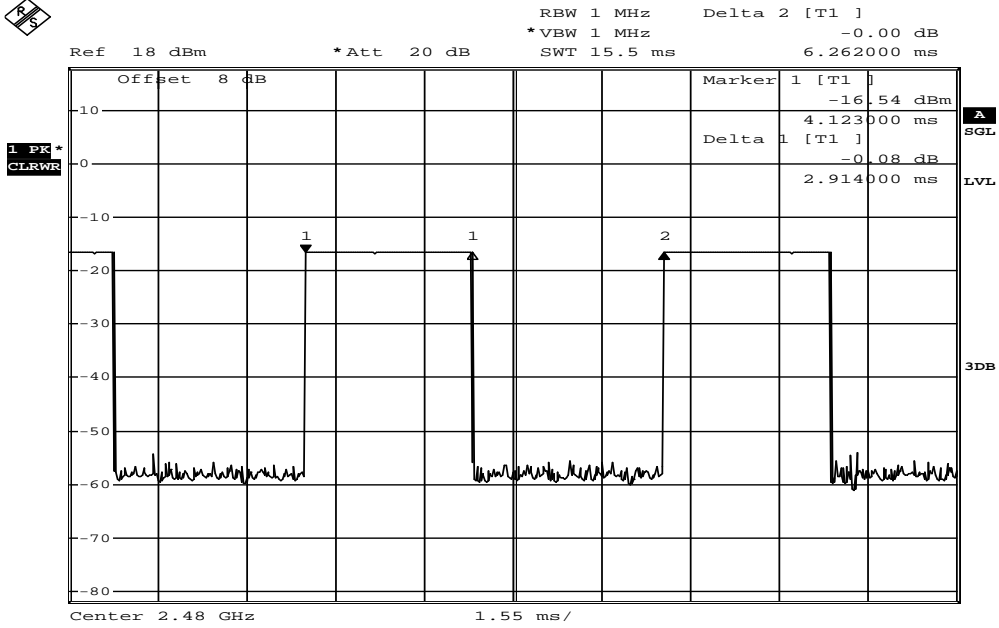

Date: 20.SEP.2011 16:09:59

12. 20dB Bandwidth & 99% Bandwidth

12.1. Standard Applicable:

According to §15.247(a)(1),and RSS210 A8.1(b) for frequency hopping systems operating in the 2400MHz-2483.5 MHz no limit for 20dB bandwidth.

12.2. Measurement Equipment Used:

Refer to section 6.2 for details.

12.3. Test Set-up:

Refer to section 6.3 for details.

12.4. Measurement Procedure:

1. Place the EUT on the table and set it in transmitting mode.
2. Remove the antenna from the EUT and then connect a low loss RF cable from the antenna port to the spectrum analyzer.
3. Set the spectrum analyzer as RBW=10KHz (1 % of Bandwidth.), Span= 3MHz, Sweep=auto
4. Mark the peak frequency and -20dB (upper and lower) frequency.
5. Repeat above procedures until all frequency measured were complete.

12.5. Measurement Result:

20dB Bandwidth

BDR Mode

CH	Bandwidth (MHz)
Lower	800.000
Mid	800.000
Higher	800.000

EDR Mode

CH	Bandwidth (MHz)	2/3 Bandwidth (MHz)
Lower	1.330	0.887
Mid	1.350	0.900
Higher	1.350	0.900

99% Bandwidth

	BDR Mode	EDR Mode
CH	Bandwidth (MHz)	Bandwidth (MHz)
Lower	0.990	1.360
Mid	0.980	1.540
Higher	1.000	1.740

Note: Refer to next page for plots.

BDR Mode
20dB Bandwidth Test Data CH-Low

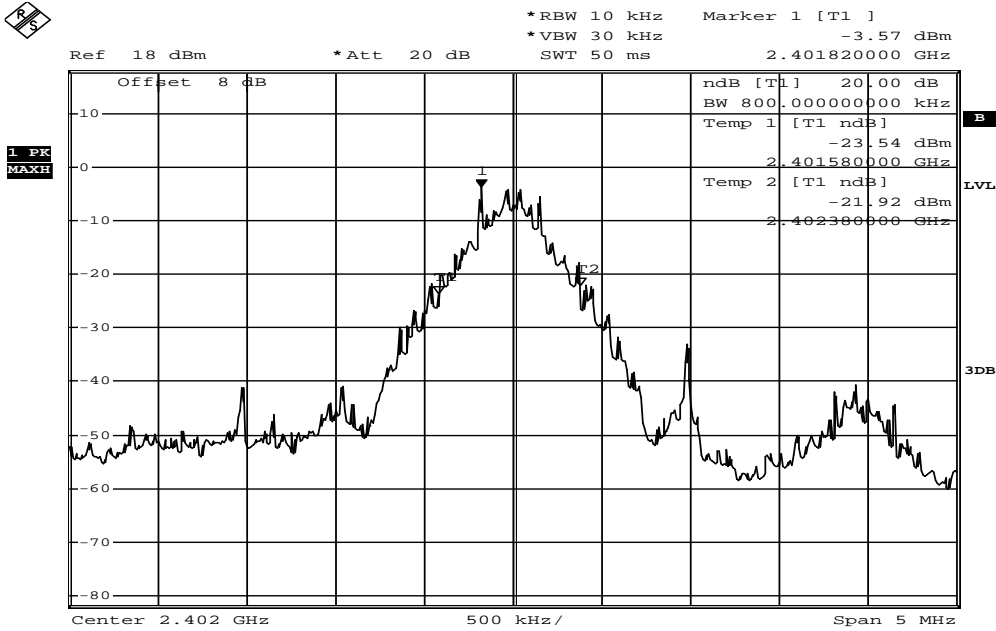

Date: 30.SEP.2011 14:04:56

20dB Bandwidth Test Data CH-Mid

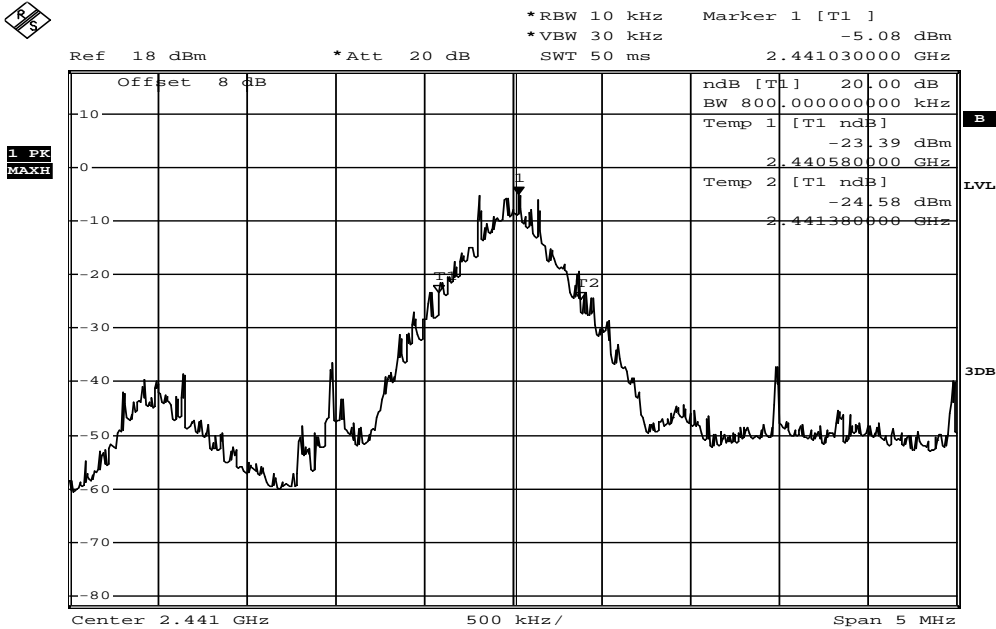

Date: 30.SEP.2011 14:05:24

20dB Bandwidth Test Data CH-High

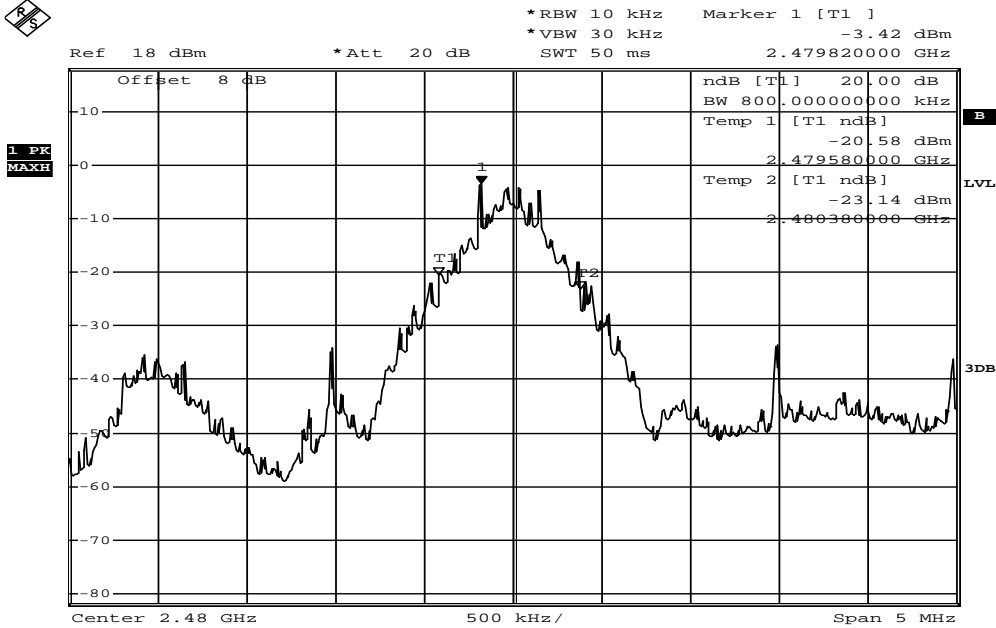

Date: 30.SEP.2011 14:06:02

EDR Mode
20dB Bandwidth Test Data CH-Low

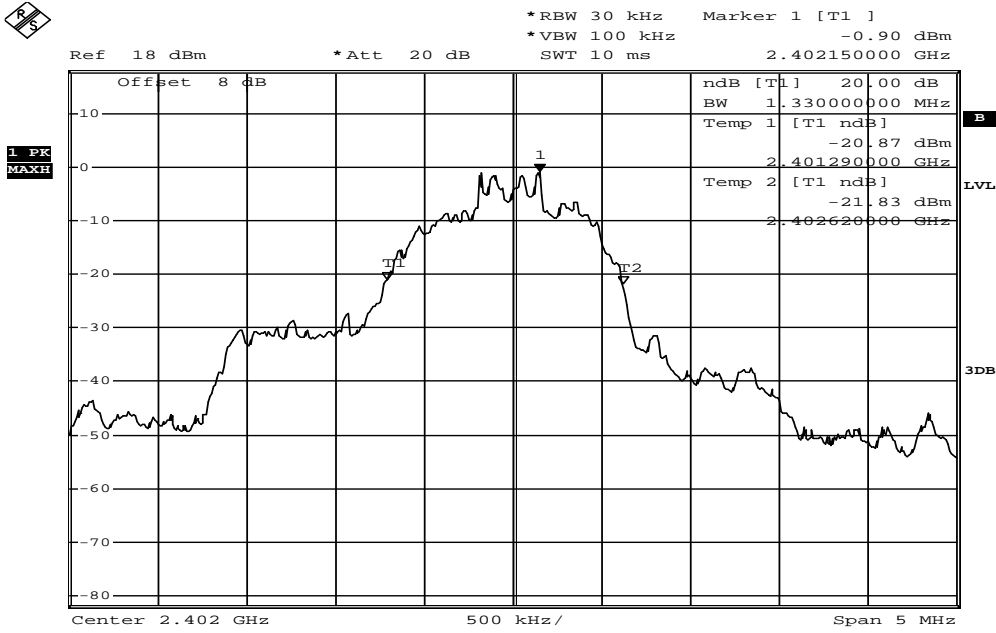

Date: 30.SEP.2011 14:39:23

20dB Bandwidth Test Data CH-Mid

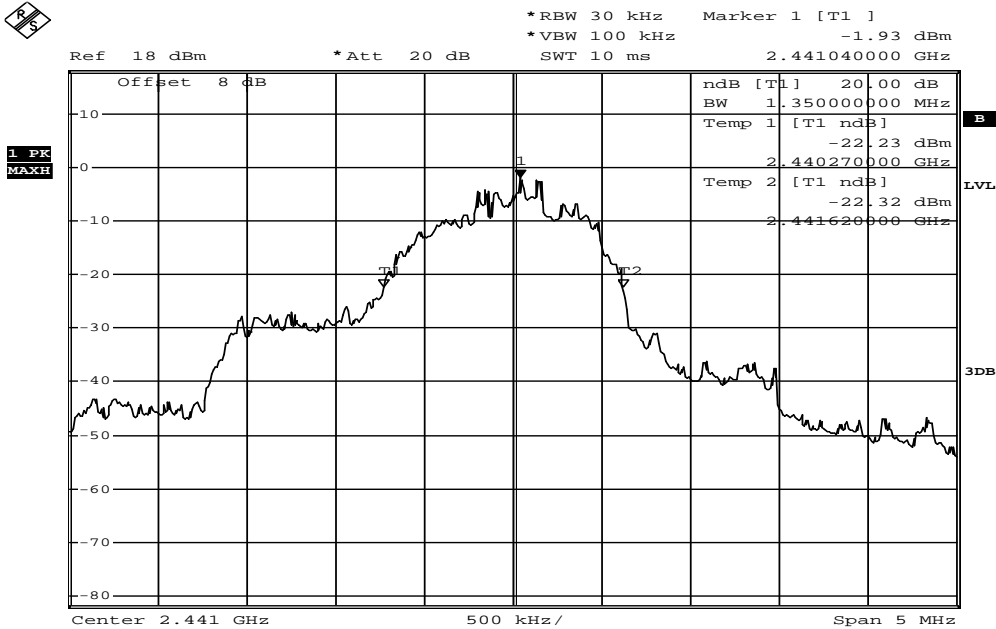

Date: 30.SEP.2011 14:36:52

20dB Bandwidth Test Data CH-High

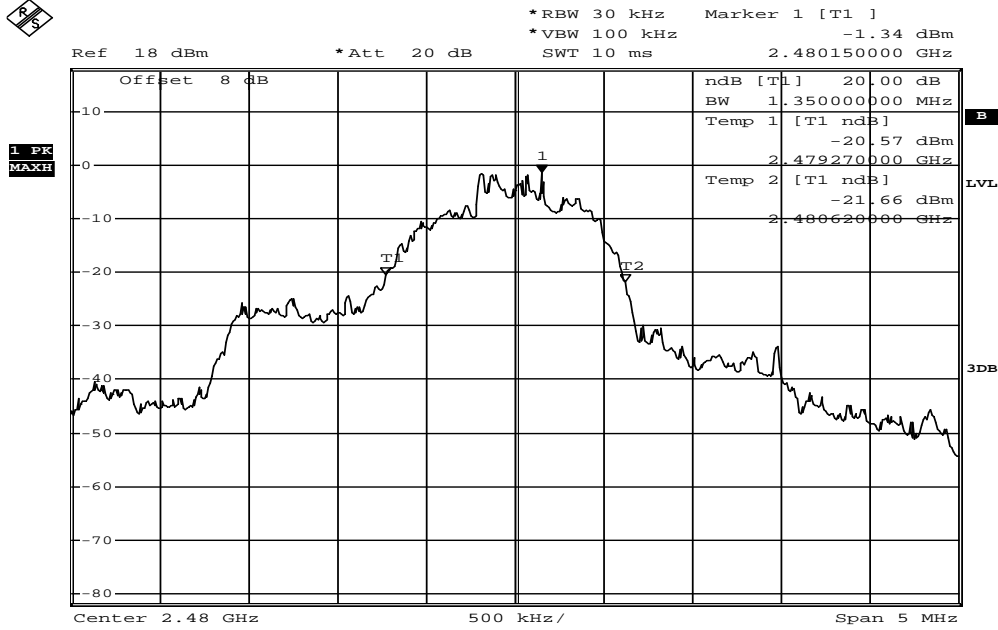

Date: 30.SEP.2011 14:36:11

BDR Mode
99% Bandwidth Test Data CH-Low

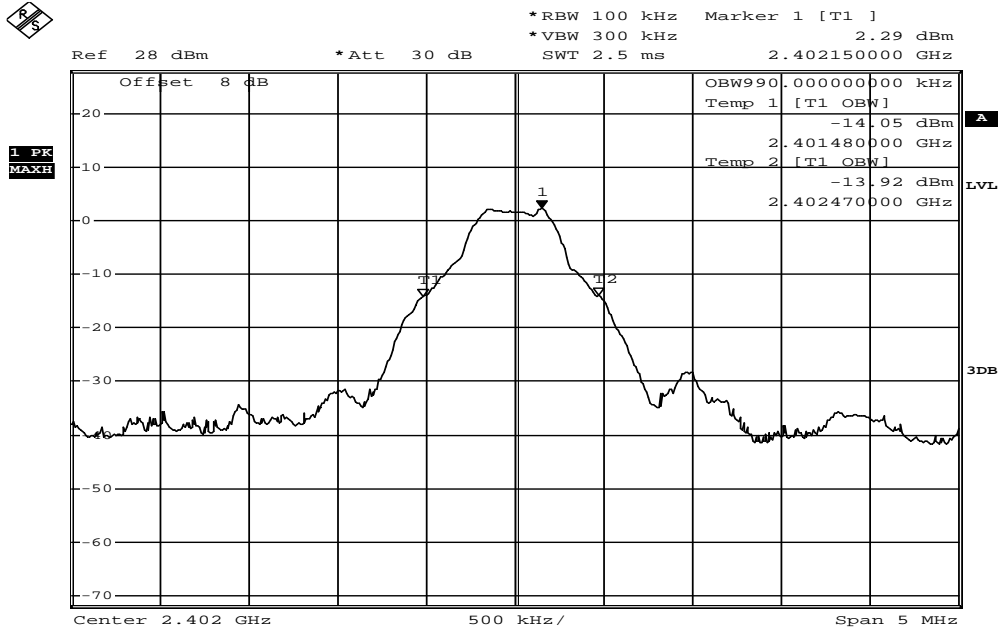

Date: 19.SEP.2011 13:29:07

99% Bandwidth Test Data CH-Mid

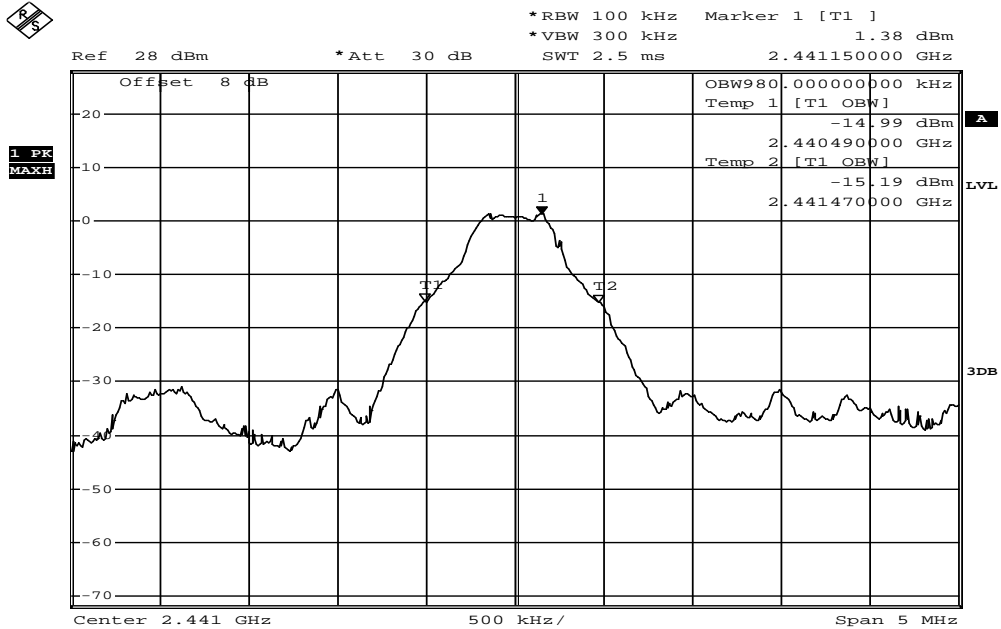

Date: 19.SEP.2011 13:30:51

99% Bandwidth Test Data CH-High

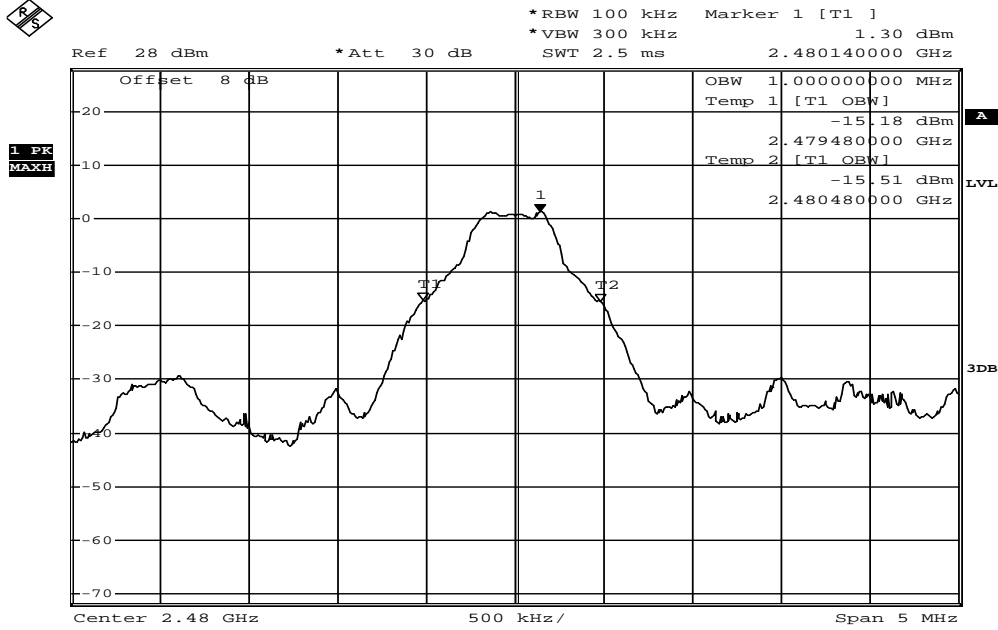

Date: 19.SEP.2011 13:31:43

EDR Mode
99% Bandwidth Test Data CH-Low

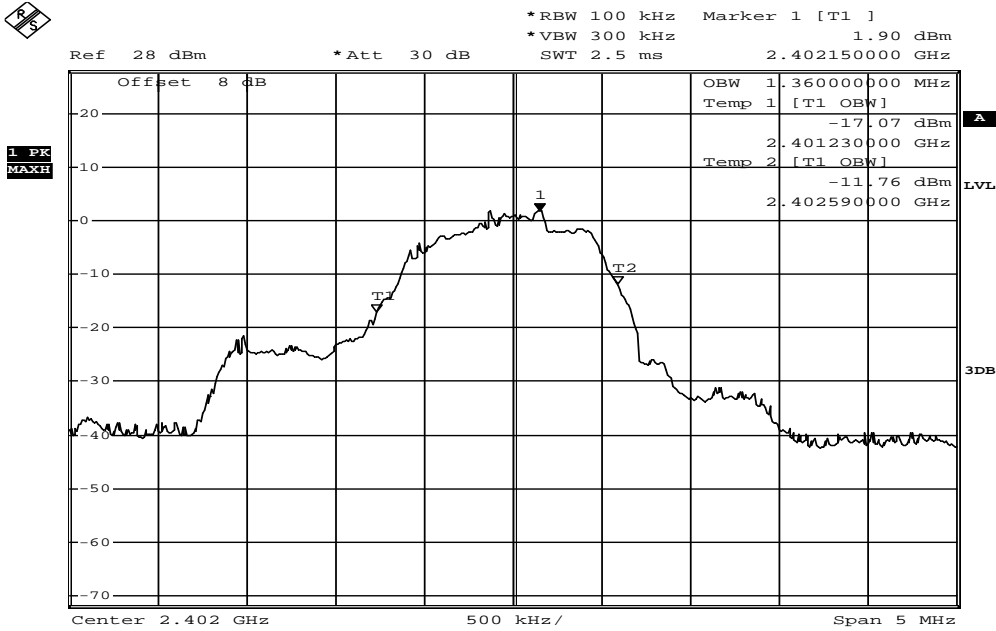

Date: 19.SEP.2011 13:39:22

99% Bandwidth Test Data CH-Mid

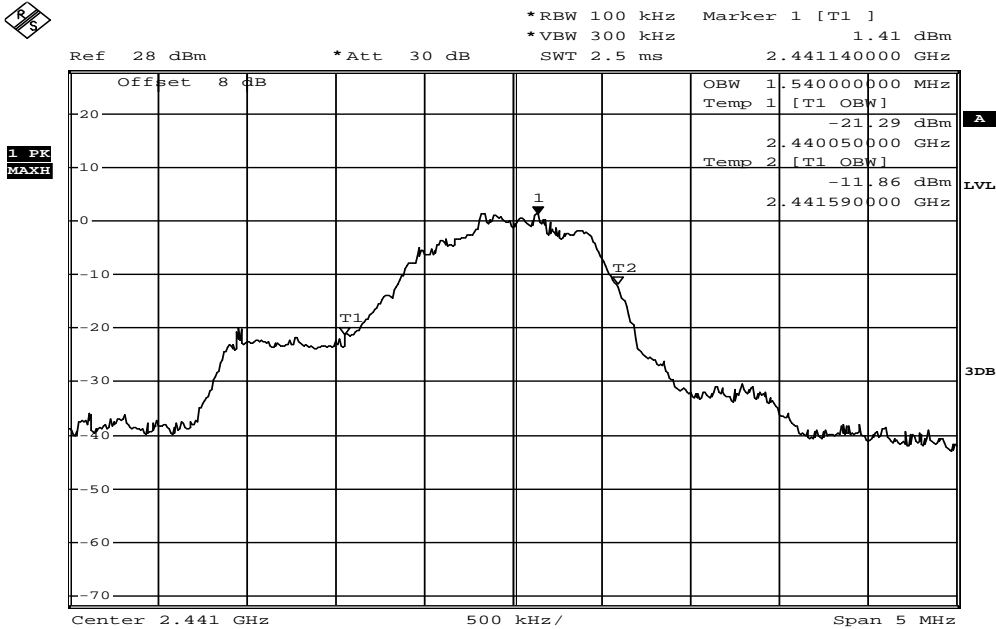

Date: 19.SEP.2011 13:45:42

99% Bandwidth Test Data CH-High

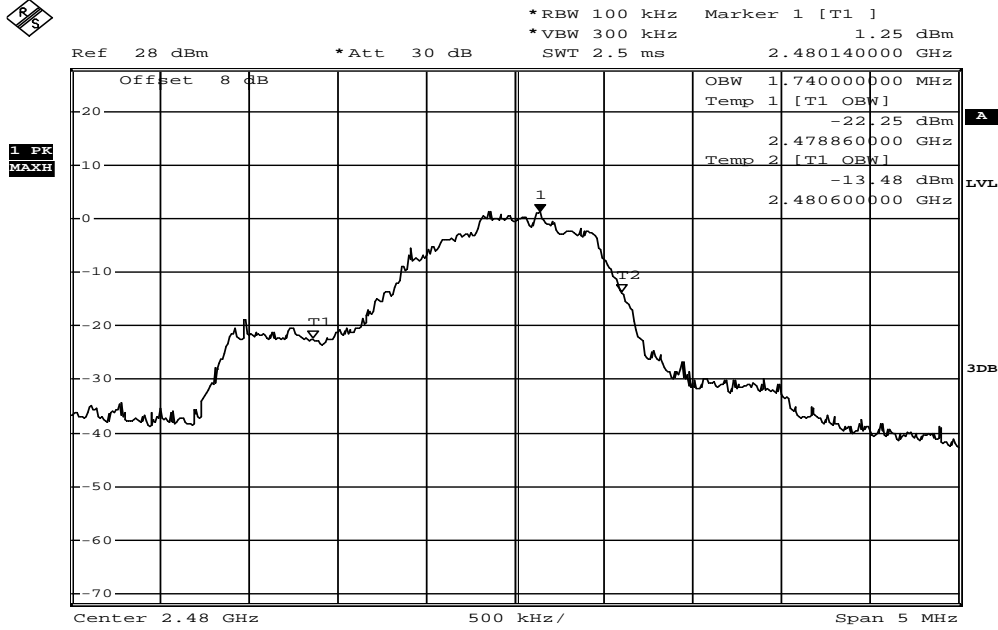

Date: 19.SEP.2011 13:51:54

13. ANTENNA REQUIREMENT

13.1. Standard Applicable:

According to §15.203, an intentional radiator shall be designed to ensure that no antenna other than furnished by the responsible party shall be used with the device.

And according to §15.246(1), if transmitting antennas of directional gain greater than 6dBi are used the power shall be reduced by the amount in dB that the directional gain of the antenna exceeds 6 dBi.

According to RSS-GEN 7.1.4, a transmitter can only be sold or operated with antennas with which it was certified. A transmitter may be certified with multiple antenna types. An antenna type comprises antennas having similar in-band and out-of-band radiation patterns. Testing shall be performed using the highest-gain antenna of each combination of transmitter and antenna type for which certification is being sought, with the transmitter output power set at the maximum level. Any antenna of the same type and having equal or lesser gain as an antenna that had been successfully tested for certification with the transmitter, will also be considered certified with the transmitter, and may be used and marketed with the transmitter. The manufacturer shall include with the application for certification a list of acceptable antenna types to be used with the transmitter.

When a measurement at the antenna connector is used to determine RF output power, the effective gain of the device's antenna shall be stated, based on measurement or on data from the antenna manufacturer. Any antenna gain in excess of 6 dBi (6 dB above isotropic gain) shall be added to the measured RF output power before using the power limits specified in RSS-210 or RSS-310 for devices of RF output powers of 10 milliwatts or less. For devices of output powers greater than 10 milliwatts, except devices subject to RSS-210 Annex 8 (Frequency Hopping and Digital Modulation Systems Operating in the 902-928 MHz, 2400-2483.5 MHz, and 5725-5850 MHz Bands) or RSS-210 Annex 9 (Local Area Network Devices), the total antenna gain shall be added to the measured RF output power before using the specified power limits. For devices subject to RSS-210 Annex 8 or Annex 9, the antenna gain shall not be added.

13.2. Antenna Connected Construction:

The directional gains of antenna used for transmitting is 4dBi, and the antenna connector is designed with permanent attachment and no consideration of replacement. Please see EUT photo for details.