



FCC RF Test Report

APPLICANT : NEC CASIO Mobile Communications, Ltd.
EQUIPMENT : Smart Phone
BRAND NAME : NEC CASIO Mobile Communications, Ltd.
MODEL NAME : NE-103T
MARKETING NAME : Dragon
FCC ID : A98-JDM2910
STANDARD : FCC 47 CFR Part 2, 22(H), 24(E)
CLASSIFICATION : PCS Licensed Transmitter Held to Ear (PCE)
Tx/Rx FREQUENCY RANGE : GSM850 : 824.2 ~ 848.8 MHz /
869.2 ~ 893.8 MHz
GSM1900 : 1850.2 ~ 1909.8 MHz /
1930.2 ~ 1989.8 MHz
WCDMA Band V : 826.4 ~ 846.6 MHz /
871.4 ~ 891.6 MHz
WCDMA Band II : 1852.4 ~ 1907.6 MHz /
1932.4 ~ 1987.6 MHz
MAX. ERP/EIRP POWER : GSM850 (GSM) : 1.0765 W
GSM850 (EDGE 8) : 0.6427 W
GSM1900 (GSM) : 0.8690 W
GSM1900 (EDGE 8) : 0.8690 W
WCDMA Band V (RMC 12.2Kbps) : 0.0940 W
WCDMA Band II (RMC 12.2Kbps) : 0.2265 W

The product was received on May 22, 2012 and completely tested on Jun. 09, 2012. We, SPORTON INTERNATIONAL INC., would like to declare that the tested sample has been evaluated in accordance with the procedures given in ANSI / TIA / EIA-603-C-2004 and shown compliance with the applicable technical standards.

The test results in this report apply exclusively to the tested model / sample. Without written approval of SPORTON INTERNATIONAL INC., the test report shall not be reproduced except in full.

Reviewed by:

Jones Tsai / Manager



SPORTON INTERNATIONAL INC.

No. 52, Hwa Ya 1st Rd., Hwa Ya Technology Park, Kwei-Shan Hsiang, Tao Yuan Hsien, Taiwan, R.O.C.

SPORTON INTERNATIONAL INC.

TEL : 886-3-327-3456

FAX : 886-3-328-4978

FCC ID : A98-JDM2910

Page Number : 1 of 92

Report Issued Date : Jun. 13, 2012

Report Version : Rev. 01



TABLE OF CONTENTS

REVISION HISTORY.....3

SUMMARY OF TEST RESULT4

1 GENERAL DESCRIPTION.....5

 1.1 Applicant.....5

 1.2 Manufacturer5

 1.3 Feature of Equipment Under Test.....5

 1.4 Emission Designator and Maximum ERP/EIRP Power6

 1.5 Testing Site6

 1.6 Applied Standards6

 1.7 Ancillary Equipment List.....7

2 TEST CONFIGURATION OF EQUIPMENT UNDER TEST.....8

 2.1 Test Mode.....8

 2.2 Connection Diagram of Test System9

3 TEST RESULT.....10

 3.1 Conducted Output Power Measurement.....10

 3.2 Effective Radiated Power and Effective Isotropic Radiated Power Measurement12

 3.3 Occupied Bandwidth Measurement23

 3.4 Band Edge Measurement.....42

 3.5 Conducted Emission Measurement55

 3.6 Field Strength of Spurious Radiation Measurement71

 3.7 Frequency Stability Measurement.....86

4 LIST OF MEASURING EQUIPMENT91

5 UNCERTAINTY OF EVALUATION.....92

APPENDIX A. PHOTOGRAPHS OF EUT

APPENDIX B. SETUP PHOTOGRAPHS



SUMMARY OF TEST RESULT

Report Section	FCC Rule	IC Rule	Description	Limit	Result	Remark
3.1	§2.1046	N/A	Conducted Output Power	N/A	PASS	-
3.2	§22.913(a)(2)	RSS-132(4.4) SRSP-503(5.1.3)	Effective Radiated Power	< 7 Watts	PASS	-
3.2	§24.232(c)	RSS-133 (6.4) SRSP-510(5.1.2)	Equivalent Isotropic Radiated Power	< 2 Watts	PASS	-
3.2	§24.232(d)	N/A	Peak-to-Average Ratio	< 13 dB	PASS	-
3.3	§2.1049 §22.917(a) §24.238(a)	N/A	Occupied Bandwidth	N/A	PASS	-
3.4	§2.1051 §22.917(a) §24.238(a)	RSS-132 (4.5.1) RSS-133 (6.5.1)	Band Edge Measurement	< 43+10log ₁₀ (P[Watts])	PASS	-
3.5	§2.1051 §22.917(a) §24.238(a)	RSS-132 (4.5.1) RSS-133 (6.5.1)	Conducted Emission	< 43+10log ₁₀ (P[Watts])	PASS	-
3.6	§2.1053 §22.917(a) §24.238(a)	RSS-132 (4.5.1) RSS-133 (6.5.1)	Field Strength of Spurious Radiation	< 43+10log ₁₀ (P[Watts])	PASS	Under limit 21.01 dB at 11280.000 MHz
3.7	§2.1055 §22.355 §24.235	RSS-132(4.3) RSS-133(6.3)	Frequency Stability for Temperature & Voltage	< 2.5 ppm	PASS	-

1 General Description

1.1 Applicant

NEC CASIO Mobile Communications, Ltd.

28Fl., Tamagawa Renaissance City Tower N, 1753 Shimonumabe, Nakahara-ku, Kawasaki, Kanagawa
211-8666 Japan

1.2 Manufacturer

Arima Communications Corp.

6F., No. 866, Jhongjheng Rd., Jhonghe City, New Taipei City 23586, Taiwan

1.3 Feature of Equipment Under Test

Product Feature & Specification	
Equipment	Smart Phone
Brand Name	NEC CASIO Mobile Communications, Ltd.
Model Name	NE-103T
Marketing Name	Dragon
FCC ID	A98-JDM2910
Tx Frequency	GSM850 : 824 MHz ~ 849 MHz GSM1900 : 1850 MHz ~ 1910 MHz WCDMA Band V : 824 MHz ~ 849 MHz WCDMA Band II : 1850 MHz ~ 1910 MHz
Rx Frequency	GSM850 : 869 MHz ~ 894 MHz GSM1900 : 1930 MHz ~ 1990 MHz WCDMA Band V : 869 MHz ~ 894 MHz WCDMA Band II : 1930 MHz ~ 1990 MHz
Maximum Output Power to Antenna	GSM850 : 32.51 dBm GSM1900 : 29.59 dBm WCDMA Band V : 22.46 dBm WCDMA Band II : 22.72 dBm
Antenna Type	PIFA Antenna
HW Version	EP1-2
SW Version	001.01.03.0.00.00
Type of Modulation	GSM: GMSK GPRS: GMSK EDGE: GMSK / 8PSK WCDMA: QPSK (Uplink) HSDPA: QPSK (Uplink)
EUT Stage	Production Unit

Remark: The above EUT's information was declared by manufacturer. Please refer to the specifications or user's manual for more detailed description.

1.4 Emission Designator and Maximum ERP/EIRP Power

FCC Rule	System	Type of Modulation	Emission Designator	Maximum ERP/EIRP
Part 22	GSM850 GSM	GMSK	248KGXW	1.0765 W
Part 22	GSM850 EDGE 8	GMSK / 8PSK	246KG7W	0.6427 W
Part 22	WCDMA Band V RMC 12.2Kbps	QPSK	4M22F9W	0.0940 W
Part 24	GSM1900 GSM	GMSK	246KGXW	0.8690 W
Part 24	GSM1900 EDGE 8	GMSK / 8PSK	244KG7W	0.8690 W
Part 24	WCDMA Band II RMC 12.2Kbps	QPSK	4M22F9W	0.2265 W

1.5 Testing Site

Test Site	SPORTON INTERNATIONAL INC.		
Test Site Location	No. 52, Hwa Ya 1 st Rd., Hwa Ya Technology Park, Kwei-Shan Hsiang, Tao Yuan Hsien, Taiwan, R.O.C. TEL: +886-3-327-3456 FAX: +886-3-328-4978		
Test Site No.	Sporton Site No.		FCC/IC Registration No.
	TH02-HY	03CH05-HY	722060/4086B-1

1.6 Applied Standards

According to the specifications of the manufacturer, the EUT must comply with the requirements of the following standards:

- ♦ Preliminary Guidance for Receiving Applications for Certification of 3G Device. May 9, 2006.
- ♦ FCC 47 CFR Part 2, 22(H), 24(E)
- ♦ ANSI / TIA / EIA-603-C-2004
- ♦ FCC KDB 971168 D01 Power Meas. License Digital Systems v01
- ♦ IC RSS-132 Issue 2
- ♦ IC RSS-133 Issue 5

Remark:

1. All test items were verified and recorded according to the standards and without any deviation during the test.
2. This EUT has also been tested and complied with the requirements of FCC Part 15, Subpart B, recorded in a separate test report.



1.7 Ancillary Equipment List

Item	Equipment	Trade Name	Model No.	FCC ID	Data Cable	Power Cord
1.	System Simulator	R&S	CMU200	N/A	N/A	Unshielded, 1.8 m

2 Test Configuration of Equipment Under Test

2.1 Test Mode

During all testing, EUT is in link mode with base station emulator at maximum power level. The spurious emission measurements were carried out in semi-anechoic chamber with 3-meter test range, and EUT is rotated on three test planes to find out the worst emission

Frequency range investigated for radiated emission is as follows:

1. 30 MHz to 9000 MHz for GSM850 and WCDMA Band V.
2. 30 MHz to 19000 MHz for GSM1900 and WCDMA Band II.

Test Modes		
Band	Radiated TCs	Conducted TCs
GSM 850	<ul style="list-style-type: none"> ■ GSM Link ■ EDGE 8 Link 	<ul style="list-style-type: none"> ■ GSM Link ■ EDGE 8 Link
GSM 1900	<ul style="list-style-type: none"> ■ GSM Link ■ EDGE 8 Link 	<ul style="list-style-type: none"> ■ GSM Link ■ EDGE 8 Link
WCDMA Band V	<ul style="list-style-type: none"> ■ RMC 12.2Kbps Link 	<ul style="list-style-type: none"> ■ RMC 12.2Kbps Link
WCDMA Band II	<ul style="list-style-type: none"> ■ RMC 12.2Kbps Link 	<ul style="list-style-type: none"> ■ RMC 12.2Kbps Link

Note:

1. The maximum power levels are GSM mode for GMSK link, EDGE multi-slot class 8 mode for 8PSK link, RMC 12.2Kbps mode for WCDMA band V, and RMC 12.2Kbps mode for WCDMA band II, only these modes were used for all tests.
2. Because there are individual antennas for each WWAN, WLAN, and Bluetooth, the co-location test modes are not required.

The conducted power tables are as follows:

Conducted Power (*Unit: dBm)						
Band	GSM850			GSM1900		
Channel	128	189	251	512	661	810
Frequency	824.2	836.4	848.8	1850.2	1880.0	1909.8
GSM	32.51	32.31	32.06	29.42	29.54	29.59
GPRS 8	32.50	32.30	32.06	29.42	29.54	29.58
GPRS 10	32.46	32.25	32.01	29.39	29.51	29.56
EGPRS 8	26.94	26.75	26.52	25.91	26.02	26.06
EGPRS 10	26.92	26.73	26.51	25.91	26.01	26.05

Conducted Power (*Unit: dBm)						
Band	WCDMA Band V			WCDMA Band II		
Channel	4132	4182	4233	9262	9400	9538
Frequency	826.4	836.4	846.6	1852.4	1880.0	1907.6
RMC 12.2K	22.46	22.26	22.24	22.72	22.45	22.68
HSDPA Subtest-1	22.39	22.28	22.27	22.55	22.24	22.54
HSDPA Subtest-2	22.22	22.19	22.12	22.52	22.24	22.51
HSDPA Subtest-3	21.75	21.71	21.65	22.08	21.87	22.18
HSDPA Subtest-4	21.73	21.66	21.62	22.05	21.88	22.14

2.2 Connection Diagram of Test System

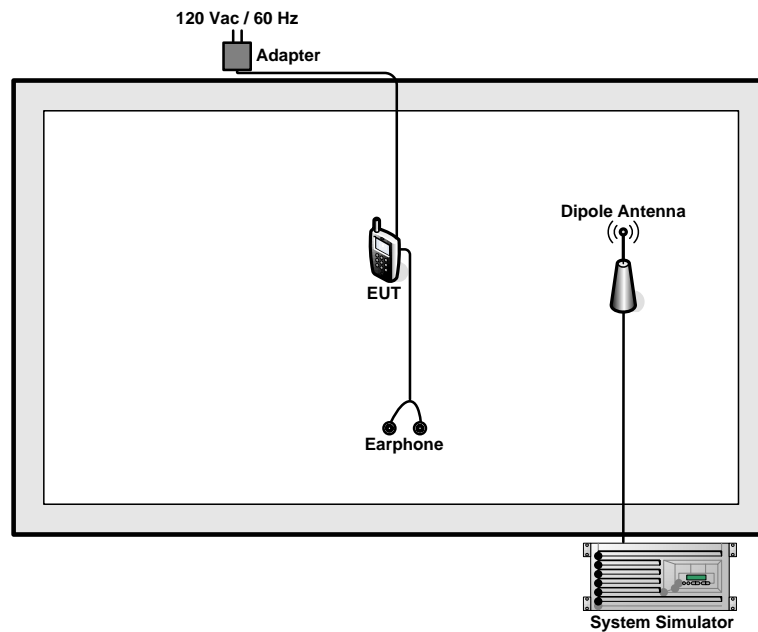

3 Test Result

3.1 Conducted Output Power Measurement

3.1.1 Description of the Conducted Output Power Measurement

A base station simulator was used to establish communication with the EUT. Its parameters were set to transmit the maximum power on the EUT. The measured power in the radio frequency on the transmitter output terminals shall be reported.

3.1.2 Measuring Instruments

See list of measuring instruments of this test report.

3.1.3 Test Procedures

1. The transmitter output port was connected to base station.
2. Set EUT at maximum power through base station.
3. Select lowest, middle, and highest channels for each band and different modulation.

3.1.4 Test Setup

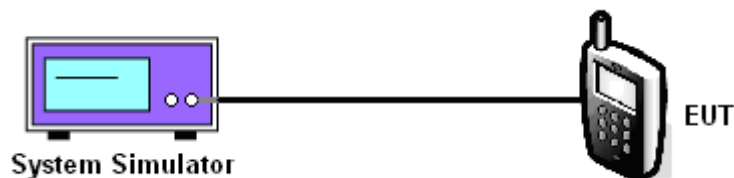

3.1.5 Test Result of Conducted Output Power

Cellular Band									
Modes	GSM850 (GSM)			GSM850 (EDGE 8)			WCDMA Band V (RMC 12.2Kbps)		
Channel	128 (Low)	189 (Mid)	251 (High)	128 (Low)	189 (Mid)	251 (High)	4132 (Low)	4182 (Mid)	4233 (High)
Frequency (MHz)	824.2	836.4	848.8	824.2	836.4	848.8	826.4	836.4	846.6
Conducted Power (dBm)	32.51	32.31	32.06	26.94	26.75	26.52	22.46	22.26	22.24
Conducted Power (Watts)	1.78	1.70	1.61	0.49	0.47	0.45	0.18	0.17	0.17

PCS Band									
Modes	GSM1900 (GSM)			GSM1900 (EDGE 8)			WCDMA Band II (RMC 12.2Kbps)		
Channel	512 (Low)	661 (Mid)	810 (High)	512 (Low)	661 (Mid)	810 (High)	9262 (Low)	9400 (Mid)	9538 (High)
Frequency (MHz)	1850.2	1880	1909.8	1850.2	1880	1909.8	1852.4	1880	1907.6
Conducted Power (dBm)	29.42	29.54	29.59	25.91	26.02	26.06	22.72	22.45	22.68
Conducted Power (Watts)	0.87	0.90	0.91	0.39	0.40	0.40	0.19	0.18	0.19

3.2 Effective Radiated Power and Effective Isotropic Radiated Power Measurement

3.2.1 Description of the ERP/EIRP Measurement

The substitution method, in ANSI / TIA / EIA-603-C-2004, was used for ERP/EIRP measurement, and the spectrum analyzer configuration follows KDB 971168 D01 Power Meas. License Digital Systems v01. The ERP of mobile transmitters must not exceed 7 Watts and the EIRP of mobile transmitters are limited to 2 Watts.

3.2.2 Measuring Instruments

See list of measuring instruments of this test report.

3.2.3 Test Procedures

1. The EUT was placed on a turntable with 1.0 meter height in a fully anechoic chamber.
2. The EUT was set at 1.2 meters from the receiving antenna, which was mounted on the antenna tower.
3. The table was rotated 360 degrees to determine the position of the highest radiated power.
4. The height of the receiving antenna is adjusted to look for the maximum ERP/EIRP.
5. Taking the record of maximum ERP/EIRP.
6. A dipole antenna was substituted in place of the EUT and was driven by a signal generator.
7. The conducted power at the terminal of the dipole antenna is measured.
8. Repeat step 3 to step 5 to get the maximum ERP/EIRP of the substitution antenna.
9. $ERP/EIRP = P_s + E_t - E_s + G_s = P_s + R_t - R_s + G_s$

P_s (dBm) : Input power to substitution antenna.

G_s (dBi or dBd) : Substitution antenna Gain.

$E_t = R_t + AF$

$E_s = R_s + AF$

AF (dB/m) : Receive antenna factor

R_t : The highest received signal in spectrum analyzer for EUT.

R_s : The highest received signal in spectrum analyzer for substitution antenna.

3.2.4 Test Setup

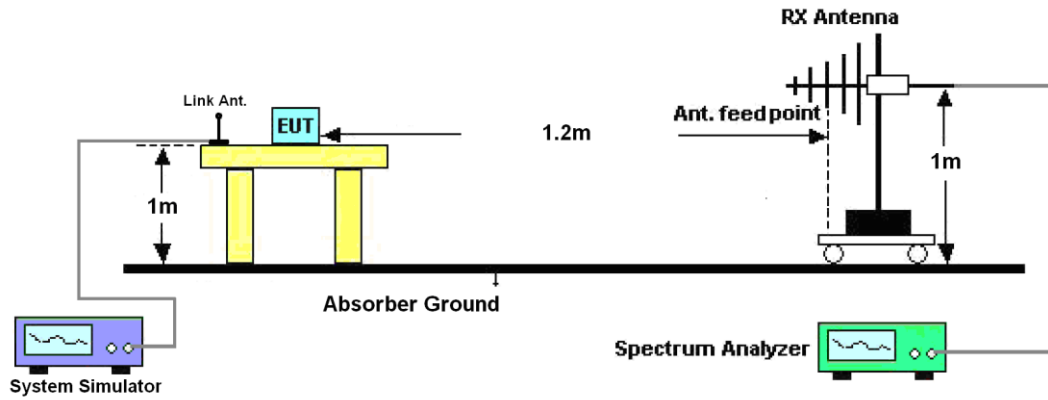



3.2.5 Test Result of ERP

GSM850 (GSM) Radiated Power ERP						
Horizontal Polarization						
Frequency (MHz)	Rt (dBm)	Rs (dBm)	Ps (dBm)	Gs (dBd)	ERP (dBm)	ERP (W)
824.20	-17.46	-48.12	0.00	-1.08	29.58	0.9078
836.40	-17.26	-48.28	0.00	-0.93	30.25	1.0593
848.80	-17.27	-48.35	0.00	-0.76	30.32	1.0765
Vertical Polarization						
Frequency (MHz)	Rt (dBm)	Rs (dBm)	Ps (dBm)	Gs (dBd)	ERP (dBm)	ERP (W)
824.20	-28.37	-47.97	0.00	-1.08	18.52	0.0711
836.40	-27.46	-48.01	0.00	-0.93	19.62	0.0916
848.80	-27.29	-48.05	0.00	-0.76	20.00	0.1000

GSM850 (EDGE 8) Radiated Power ERP						
Horizontal Polarization						
Frequency (MHz)	Rt (dBm)	Rs (dBm)	Ps (dBm)	Gs (dBd)	ERP (dBm)	ERP (W)
824.20	-19.32	-48.12	0.00	-1.08	27.72	0.5916
836.40	-19.27	-48.28	0.00	-0.93	28.08	0.6427
848.80	-19.52	-48.35	0.00	-0.76	28.07	0.6412
Vertical Polarization						
Frequency (MHz)	Rt (dBm)	Rs (dBm)	Ps (dBm)	Gs (dBd)	ERP (dBm)	ERP (W)
824.20	-30.35	-47.97	0.00	-1.08	16.54	0.0451
836.40	-29.77	-48.01	0.00	-0.93	17.31	0.0538
848.80	-29.29	-48.05	0.00	-0.76	18.00	0.0631



WCDMA Band V (RMC 12.2Kbps) Radiated Power ERP						
Horizontal Polarization						
Frequency (MHz)	Rt (dBm)	Rs (dBm)	Ps (dBm)	Gs (dBd)	ERP (dBm)	ERP (W)
826.40	-27.70	-48.12	0.00	-1.08	19.34	0.0859
836.40	-28.42	-48.28	0.00	-0.93	18.93	0.0782
846.60	-27.86	-48.35	0.00	-0.76	19.73	0.0940
Vertical Polarization						
Frequency (MHz)	Rt (dBm)	Rs (dBm)	Ps (dBm)	Gs (dBd)	ERP (dBm)	ERP (W)
826.40	-38.29	-47.97	0.00	-1.08	8.60	0.0072
836.40	-38.93	-48.01	0.00	-0.93	8.15	0.0065
846.60	-37.65	-48.05	0.00	-0.76	9.64	0.0092



3.2.6 Test Result of EIRP

GSM1900 (GSM) Radiated Power EIRP						
Horizontal Polarization						
Frequency (MHz)	Rt (dBm)	Rs (dBm)	Ps (dBm)	Gs (dBi)	EIRP (dBm)	EIRP (W)
1850.20	-25.00	-51.88	0.00	1.96	28.84	0.7656
1880.00	-25.68	-52.99	0.00	2.00	29.31	0.8531
1909.80	-27.68	-54.28	0.00	1.98	28.58	0.7211
Vertical Polarization						
Frequency (MHz)	Rt (dBm)	Rs (dBm)	Ps (dBm)	Gs (dBi)	EIRP (dBm)	EIRP (W)
1850.20	-24.70	-52.13	0.00	1.96	29.39	0.8690
1880.00	-26.19	-53.17	0.00	2.00	28.98	0.7907
1909.80	-27.93	-54.13	0.00	1.98	28.18	0.6577

GSM1900 (EDGE 8) Radiated Power EIRP						
Horizontal Polarization						
Frequency (MHz)	Rt (dBm)	Rs (dBm)	Ps (dBm)	Gs (dBi)	EIRP (dBm)	EIRP (W)
1850.20	-25.95	-51.88	0.00	1.96	27.89	0.6152
1880.00	-26.30	-52.99	0.00	2.00	28.69	0.7396
1909.80	-28.13	-54.28	0.00	1.98	28.13	0.6501
Vertical Polarization						
Frequency (MHz)	Rt (dBm)	Rs (dBm)	Ps (dBm)	Gs (dBi)	EIRP (dBm)	EIRP (W)
1850.20	-24.82	-52.13	0.00	1.96	29.27	0.8453
1880.00	-25.78	-53.17	0.00	2.00	29.39	0.8690
1909.80	-27.67	-54.13	0.00	1.98	28.44	0.6982



WCDMA Band II (RMC 12.2Kbps) Radiated Power EIRP						
Horizontal Polarization						
Frequency (MHz)	Rt (dBm)	Rs (dBm)	Ps (dBm)	Gs (dBi)	EIRP (dBm)	EIRP (W)
1852.40	-30.90	-51.88	0.00	1.96	22.94	0.1968
1880.00	-32.59	-52.99	0.00	2.00	22.40	0.1738
1907.60	-34.14	-54.28	0.00	1.98	22.12	0.1629
Vertical Polarization						
Frequency (MHz)	Rt (dBm)	Rs (dBm)	Ps (dBm)	Gs (dBi)	EIRP (dBm)	EIRP (W)
1852.40	-30.54	-52.13	0.00	1.96	23.55	0.2265
1880.00	-32.65	-53.17	0.00	2.00	22.52	0.1786
1907.60	-33.84	-54.13	0.00	1.98	22.27	0.1687



3.2.7 Peak to Average Power Ratio

GSM1900 (GSM) C.C.D.F.

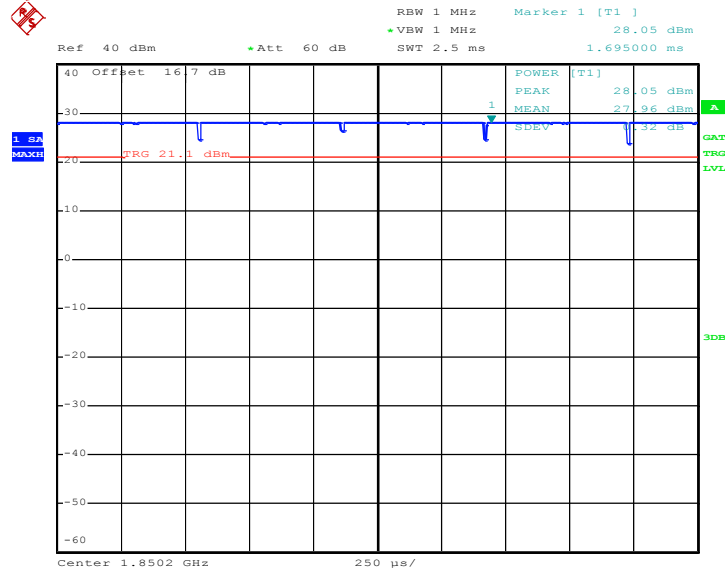

Date: 8.JUN.2012 10:19:52

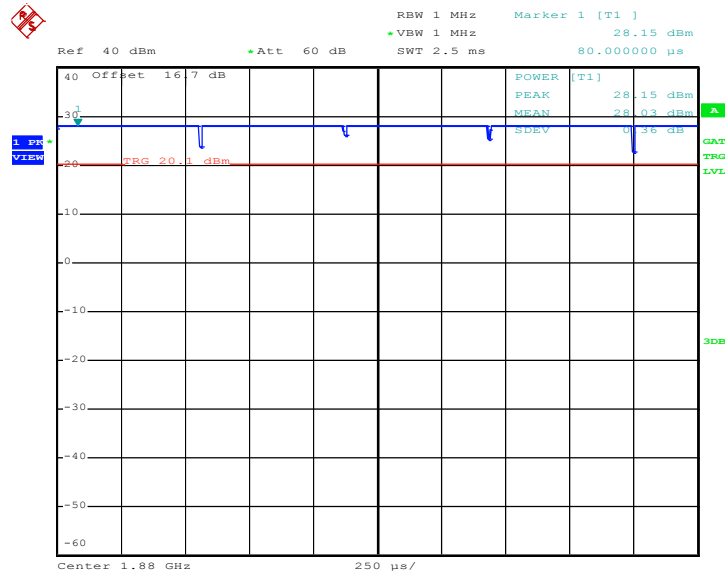

Date: 8.JUN.2012 10:10:27

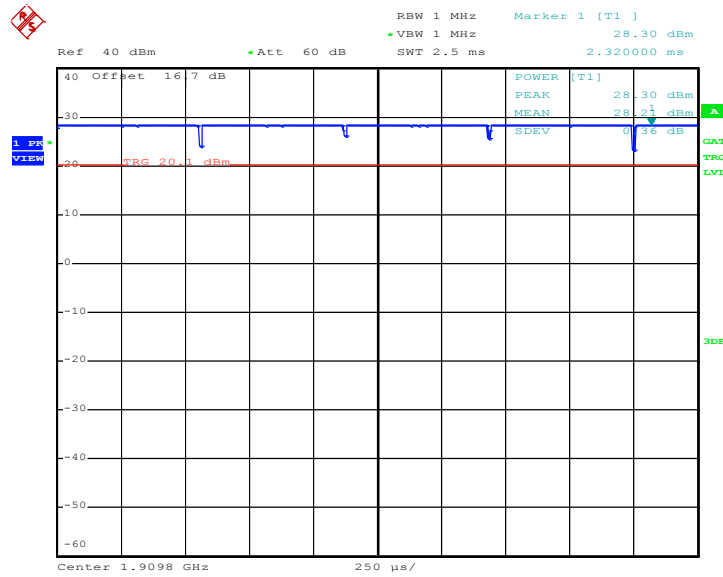

Date: 8.JUN.2012 10:09:35

GSM1900 (EDGE 8) C.C.D.F.

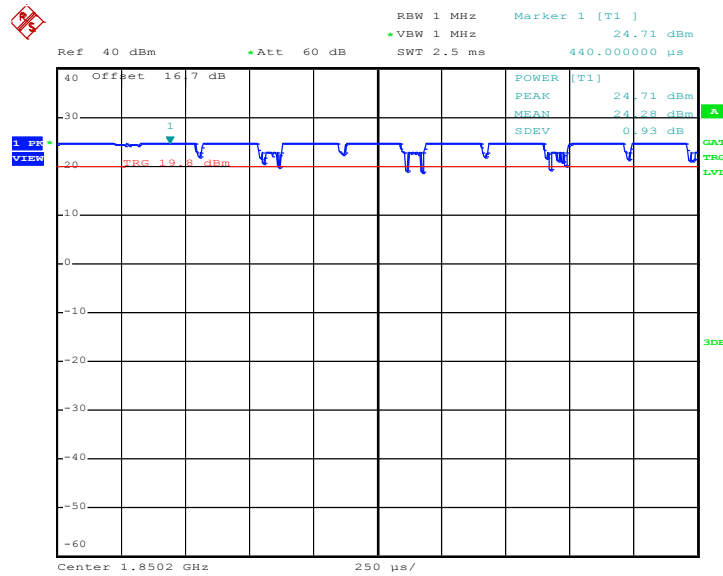

Date: 8.JUN.2012 10:36:03

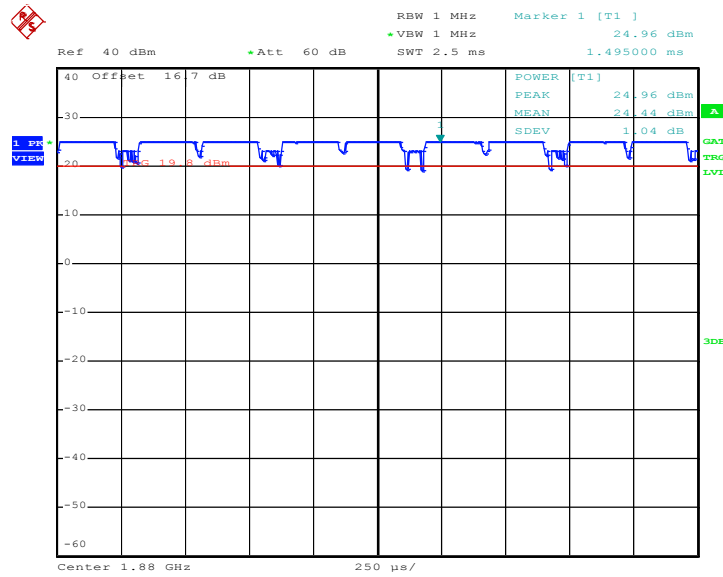

Date: 8.JUN.2012 10:36:35

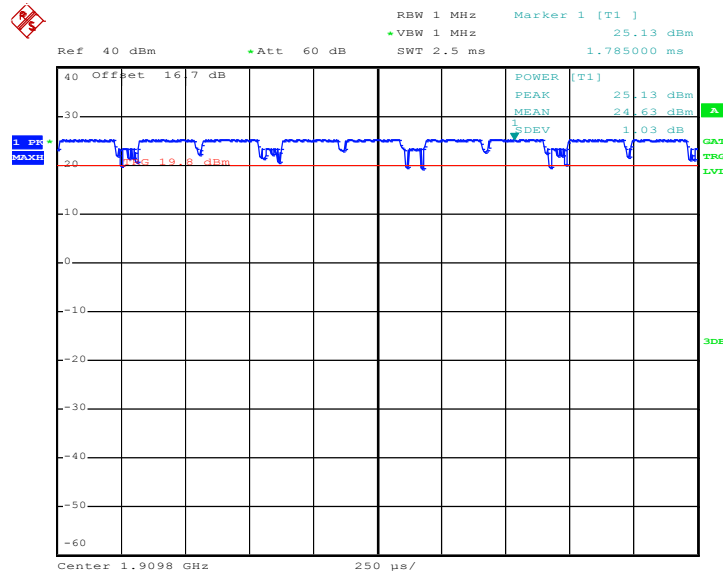

Date: 8.JUN.2012 10:37:07



WCDMA Band II (RMC 12.2Kbps) C.C.D.F.

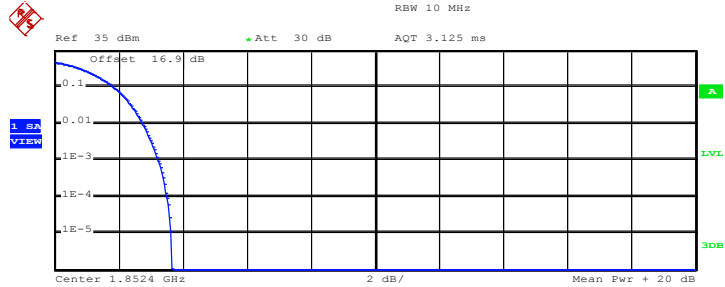

Complementary Cumulative Distribution Function (100000 samples)

Trace 1

Mean 22.19 dBm
 Peak 25.87 dBm
 Crest 3.67 dB

10 % 1.88 dB
 1 % 2.76 dB
 .1 % 3.24 dB
 .01 % 3.52 dB

Date: 29.MAY.2012 01:12:26

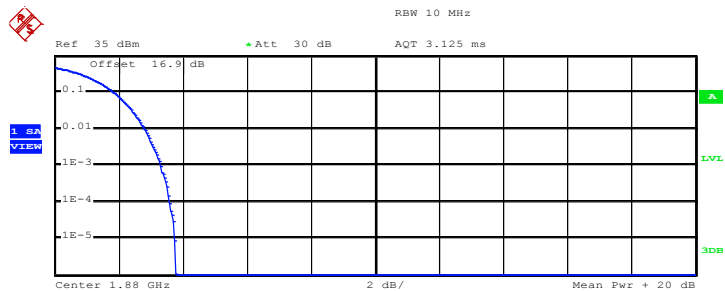

Complementary Cumulative Distribution Function (100000 samples)

Trace 1

Mean 21.89 dBm
 Peak 25.66 dBm
 Crest 3.77 dB

10 % 1.88 dB
 1 % 2.80 dB
 .1 % 3.32 dB
 .01 % 3.60 dB

Date: 29.MAY.2012 01:11:56

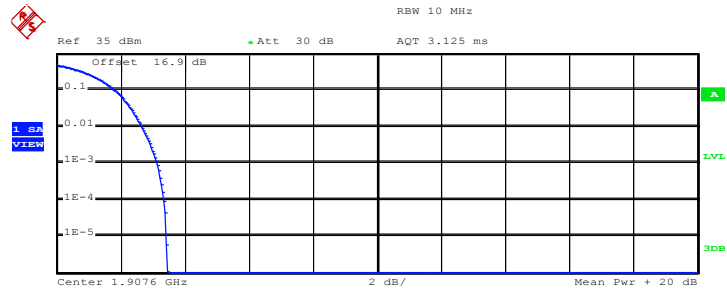

Complementary Cumulative Distribution Function (100000 samples)

Trace 1

Mean 22.01 dBm
Peak 25.45 dBm
Crest 3.44 dB

10 % 1.84 dB
1 % 2.68 dB
.1 % 3.16 dB
.01 % 3.36 dB

Date: 29.MAY.2012 01:12:55

3.3 Occupied Bandwidth Measurement

3.3.1 Description of Occupied Bandwidth Measurement

The emission bandwidth is defined as the width of the signal between two points, located at the 2 sides of the carrier frequency, outside of which all emissions are attenuated at least 26 dB below the transmitter power.

3.3.2 Measuring Instruments

See list of measuring instruments of this test report.

3.3.3 Test Procedures

1. The EUT was connected to Spectrum Analyzer and Base Station via power divider.
2. The 99% and 26 dB occupied bandwidth (BW) of the middle channel for the highest RF powers were measured.

3.3.4 Test Setup

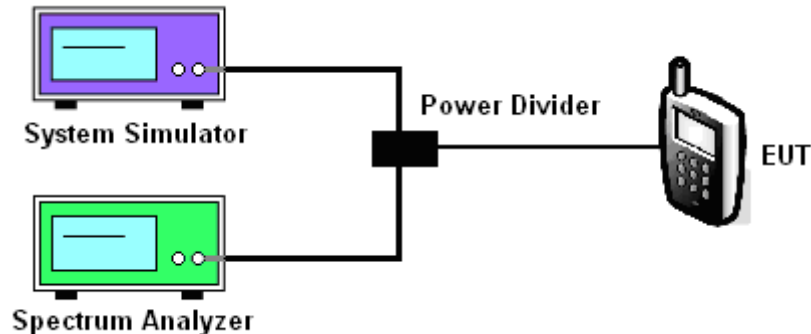



3.3.5 Test Result (Plots) of Occupied Bandwidth

Band :	GSM 850	Power Stage :	High
Test Mode :	GSM Link		

99% Occupied Bandwidth Plot on Channel 128

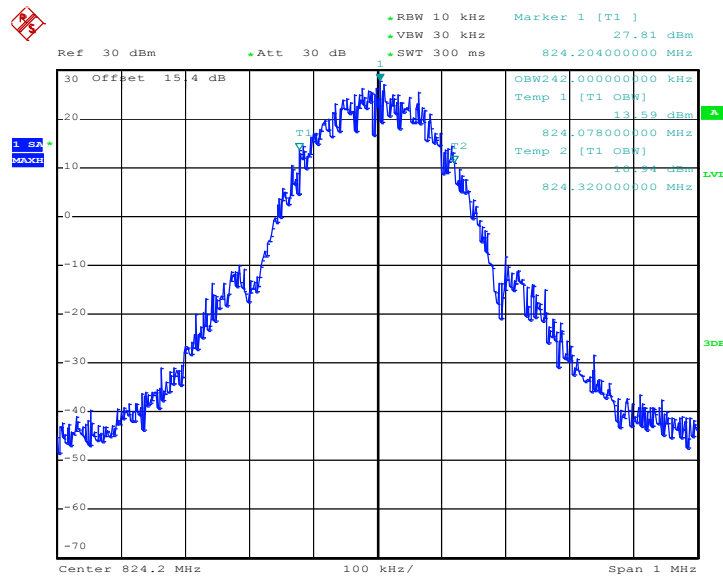

Date: 8.JUN.2012 09:25:09

26dB Bandwidth Plot on Channel 128

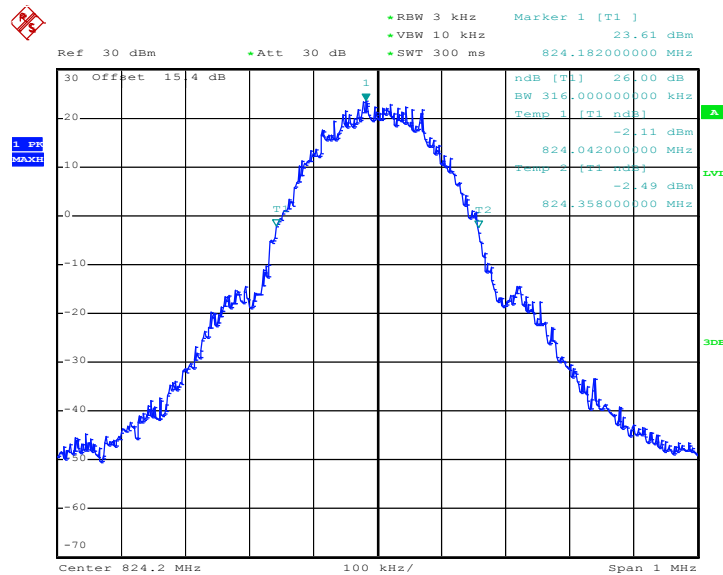

Date: 8.JUN.2012 09:23:50



99% Occupied Bandwidth Plot on Channel 251

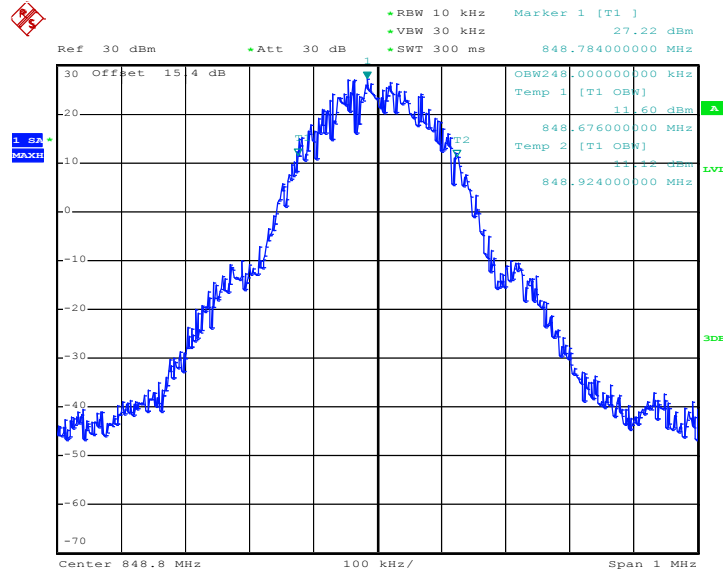

Date: 8.JUN.2012 09:26:01

26dB Bandwidth Plot on Channel 251

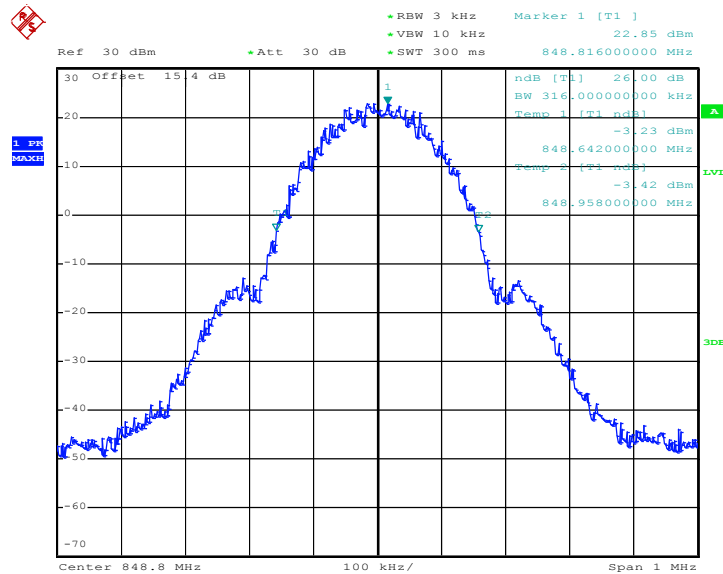

Date: 8.JUN.2012 09:24:43



Band :	GSM 850	Power Stage :	High
Test Mode :	EDGE 8 Link		

99% Occupied Bandwidth Plot on Channel 128

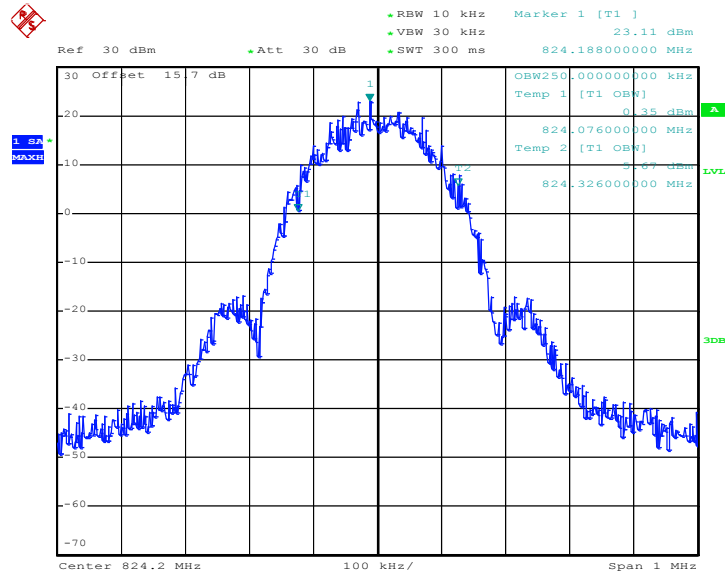

Date: 29.MAY.2012 01:02:16

26dB Bandwidth Plot on Channel 128

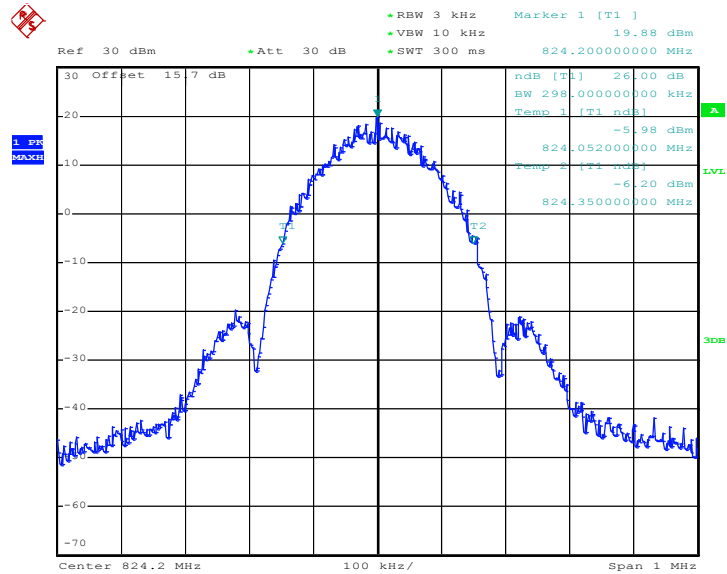

Date: 29.MAY.2012 01:00:57



99% Occupied Bandwidth Plot on Channel 189

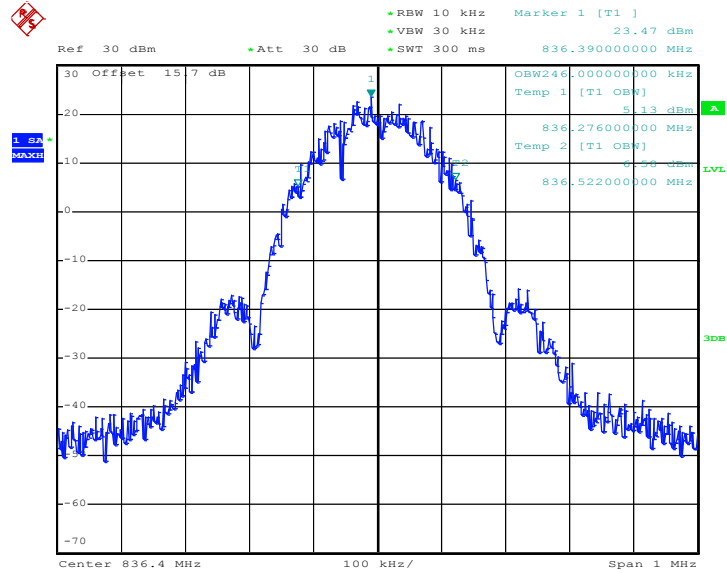

Date: 29.MAY.2012 01:02:42

26dB Bandwidth Plot on Channel 189

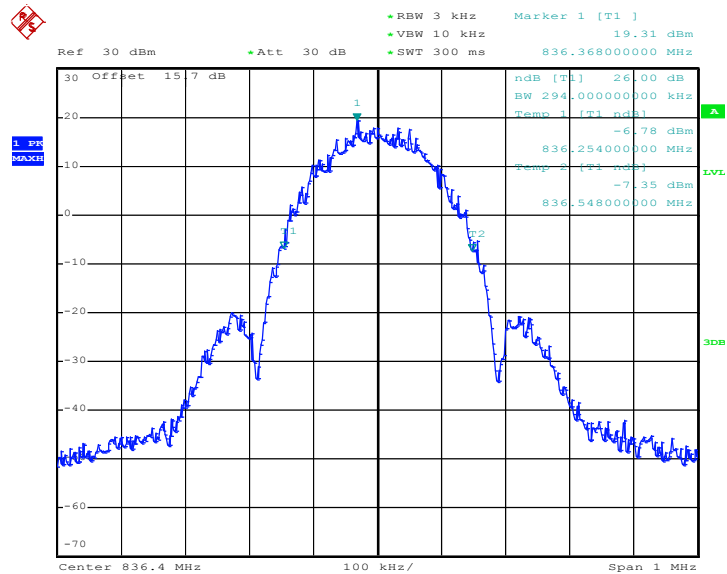

Date: 29.MAY.2012 01:01:23



99% Occupied Bandwidth Plot on Channel 251

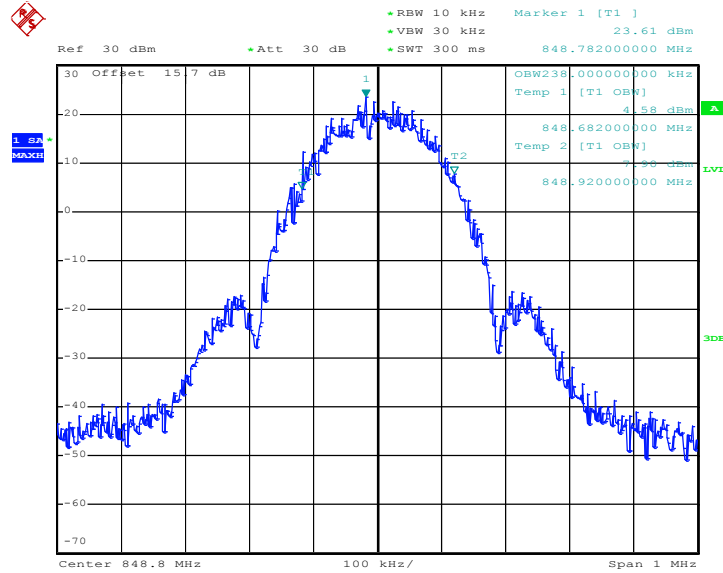

Date: 29.MAY.2012 01:03:08

26dB Bandwidth Plot on Channel 251

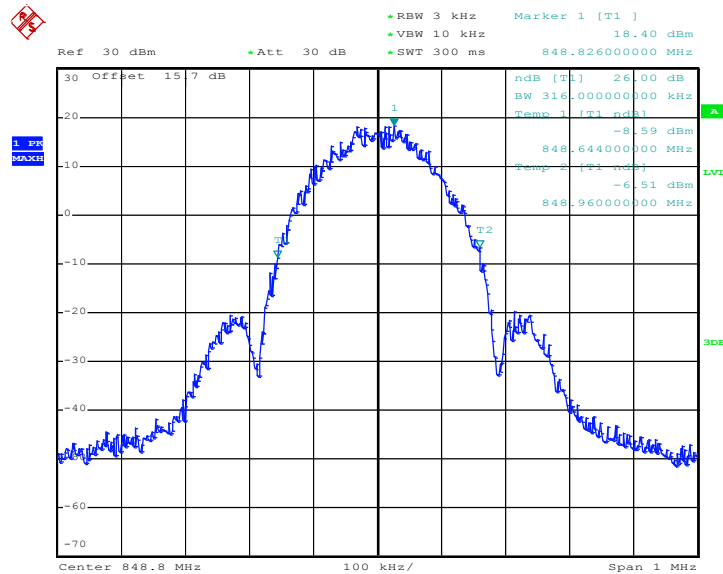

Date: 29.MAY.2012 01:01:49



Band :	GSM 1900	Power Stage :	High
Test Mode :	GSM Link		

99% Occupied Bandwidth Plot on Channel 512

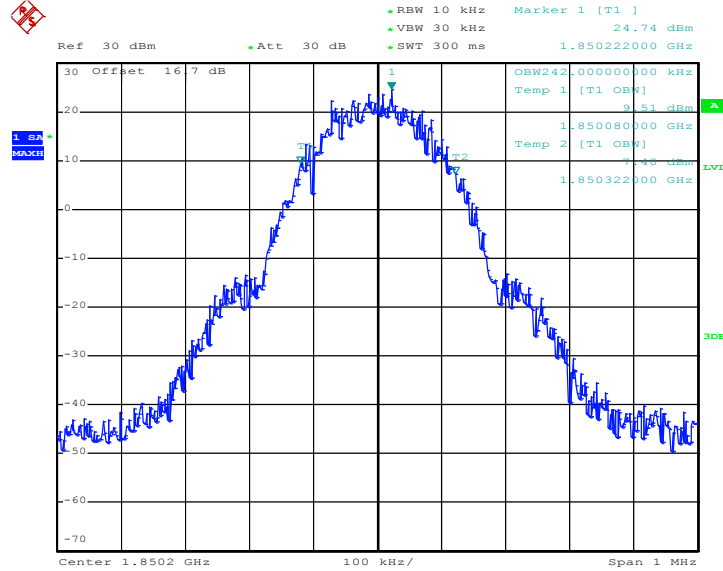

Date: 8.JUN.2012 10:00:50

26dB Bandwidth Plot on Channel 512

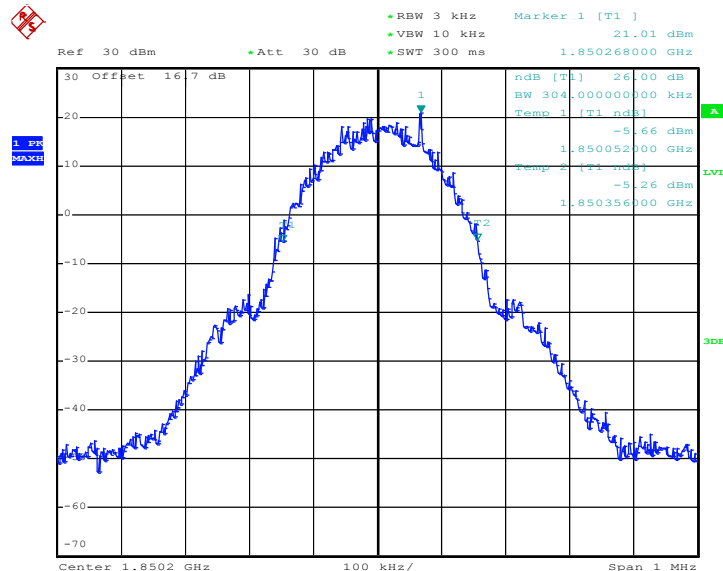

Date: 8.JUN.2012 09:59:31



99% Occupied Bandwidth Plot on Channel 661

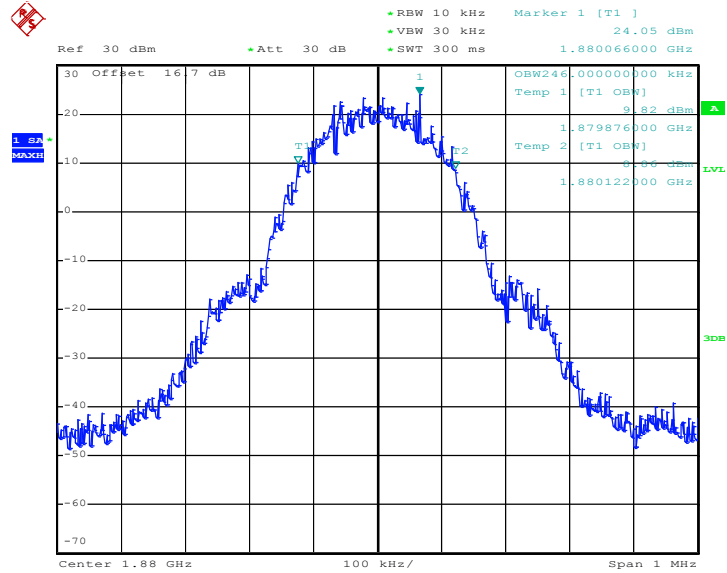

Date: 8.JUN.2012 10:01:16

26dB Bandwidth Plot on Channel 661

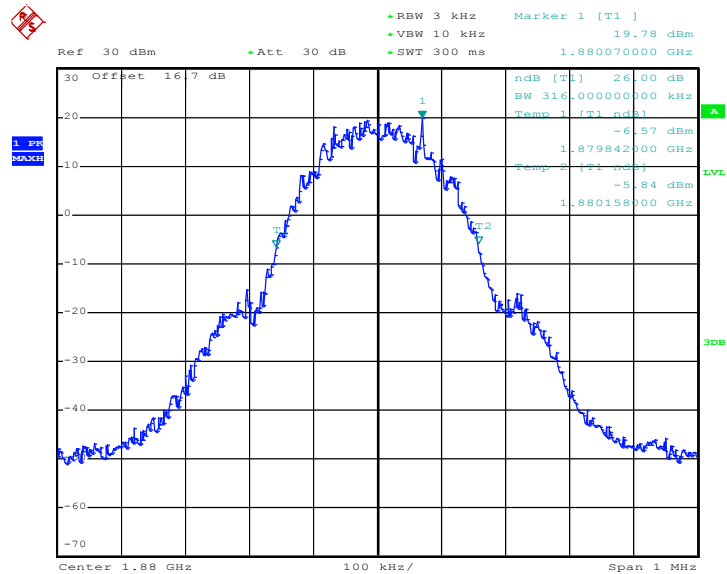

Date: 8.JUN.2012 09:59:58



99% Occupied Bandwidth Plot on Channel 810

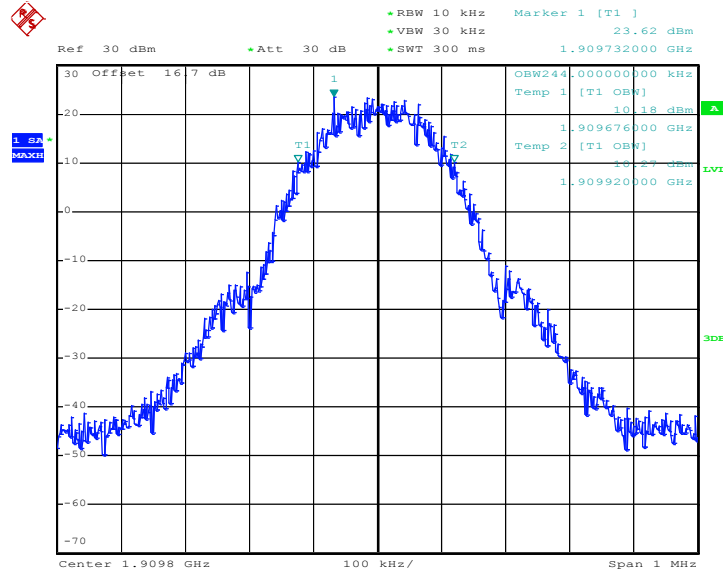

Date: 8.JUN.2012 10:01:42

26dB Bandwidth Plot on Channel 810

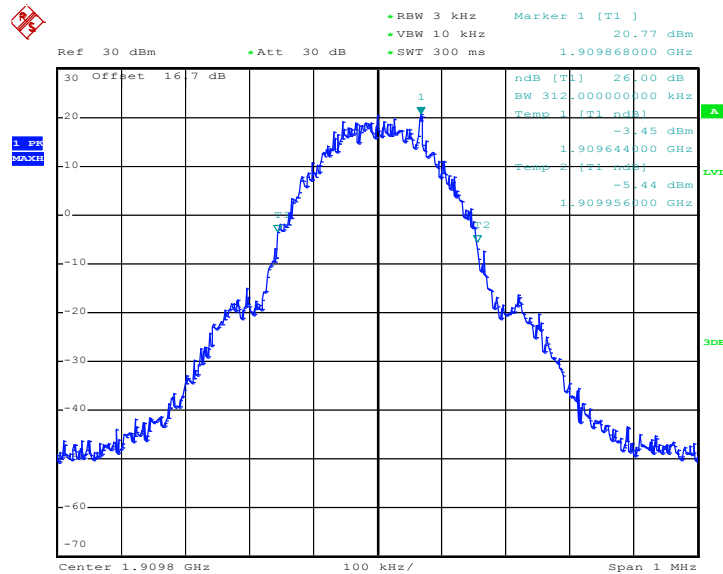

Date: 8.JUN.2012 10:00:24



Band :	GSM 1900	Power Stage :	High
Test Mode :	EDGE 8 Link		

99% Occupied Bandwidth Plot on Channel 512

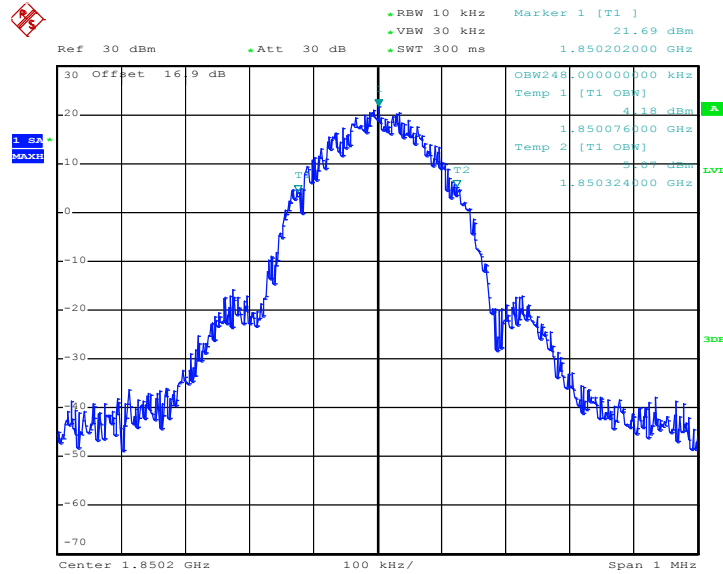

Date: 29.MAY.2012 00:44:25

26dB Bandwidth Plot on Channel 512

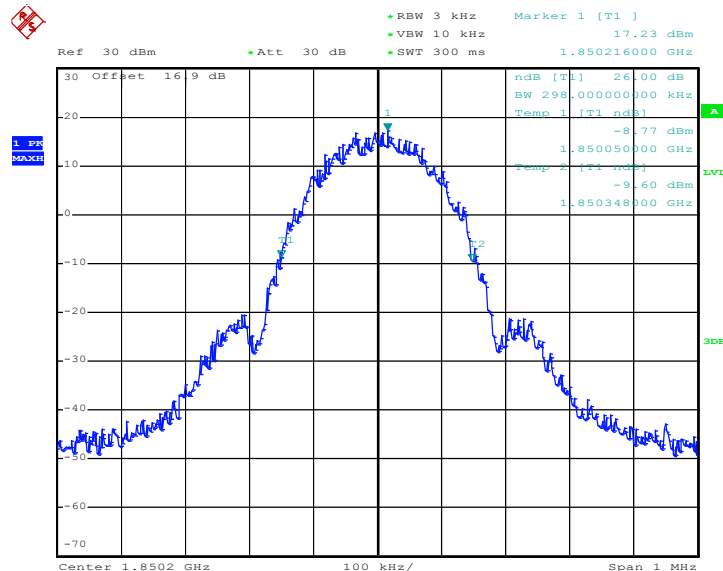

Date: 29.MAY.2012 00:43:06



99% Occupied Bandwidth Plot on Channel 661

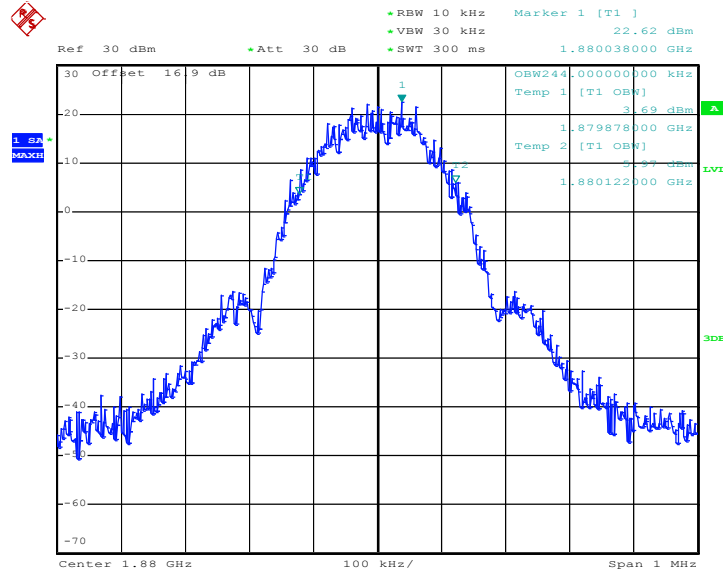

Date: 29.MAY.2012 00:44:51

26dB Bandwidth Plot on Channel 661

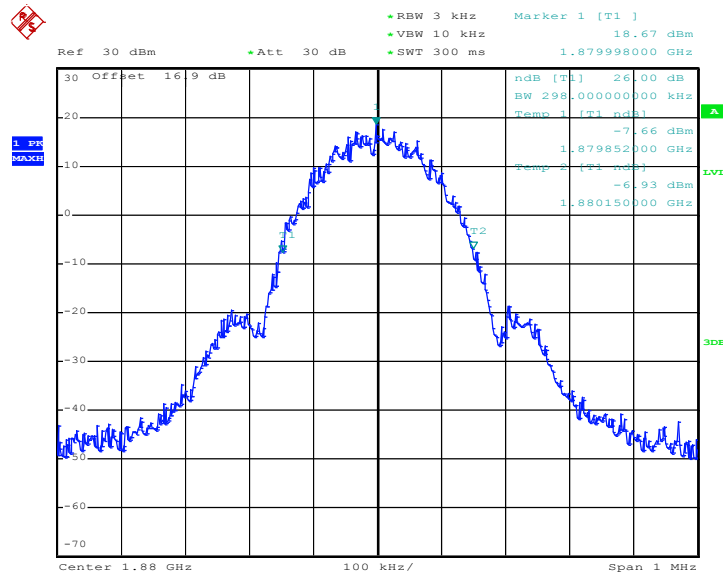

Date: 29.MAY.2012 00:43:32



99% Occupied Bandwidth Plot on Channel 810

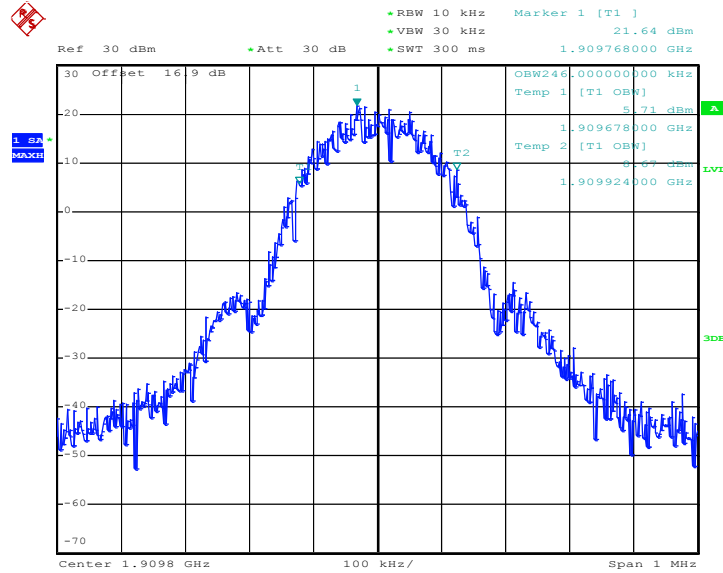

Date: 29.MAY.2012 00:45:16

26dB Bandwidth Plot on Channel 810

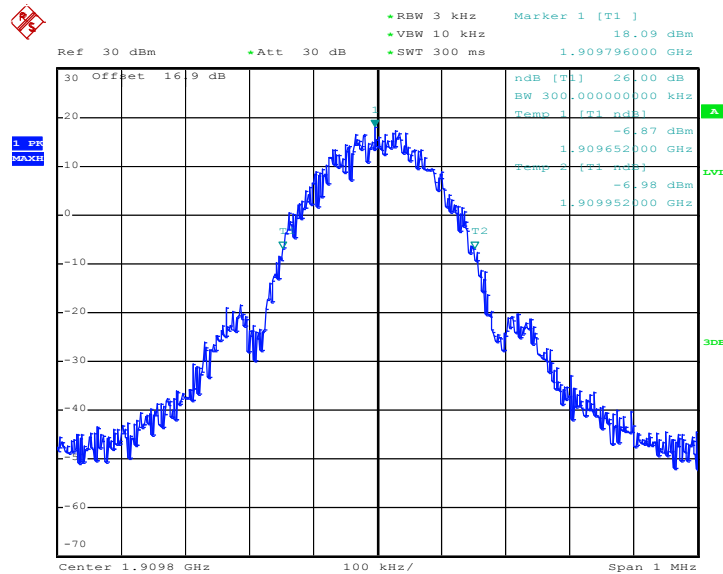

Date: 29.MAY.2012 00:43:58



Band :	WCDMA Band V	Power Stage :	High
Test Mode :	RMC 12.2Kbps Link		

99% Occupied Bandwidth Plot on Channel 4132

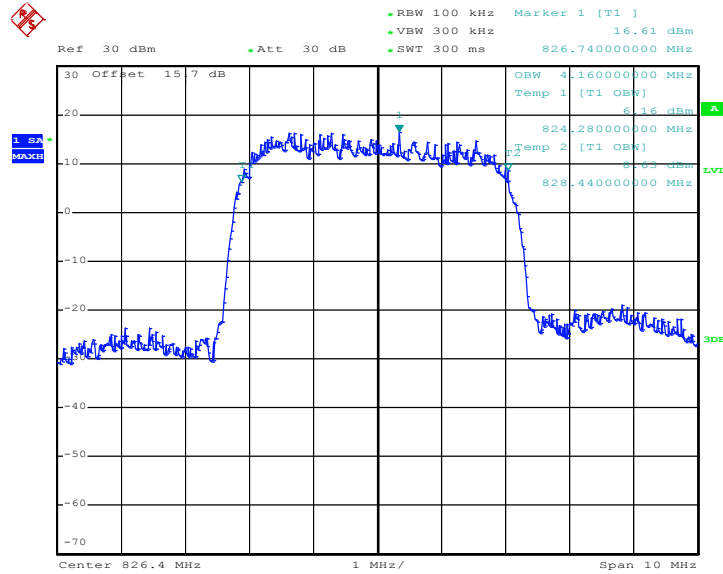

Date: 29.MAY.2012 01:27:28

26dB Bandwidth Plot on Channel 4132

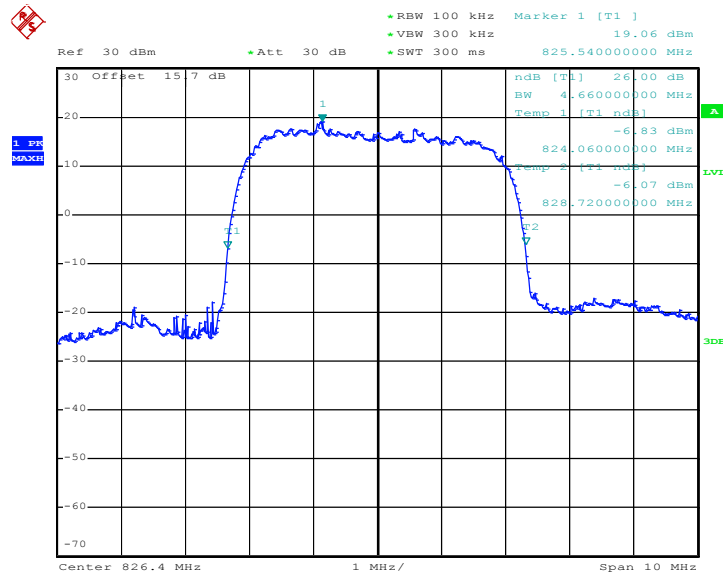

Date: 29.MAY.2012 01:26:09



99% Occupied Bandwidth Plot on Channel 4182

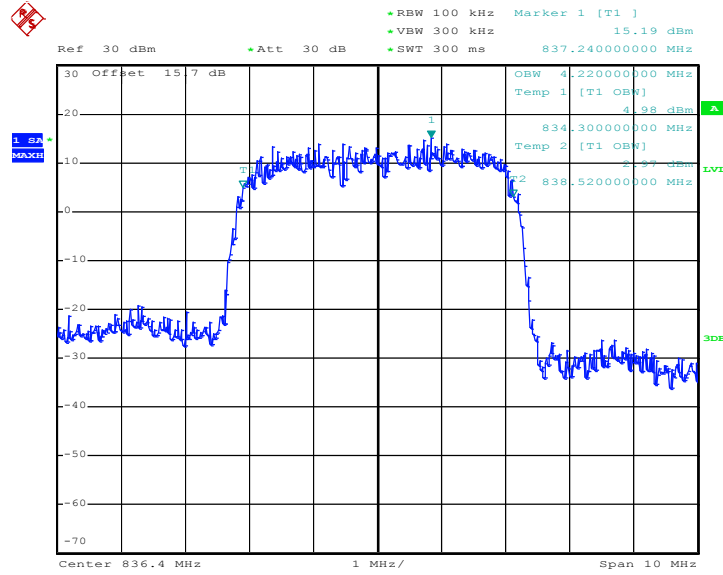

Date: 29.MAY.2012 01:27:54

26dB Bandwidth Plot on Channel 4182

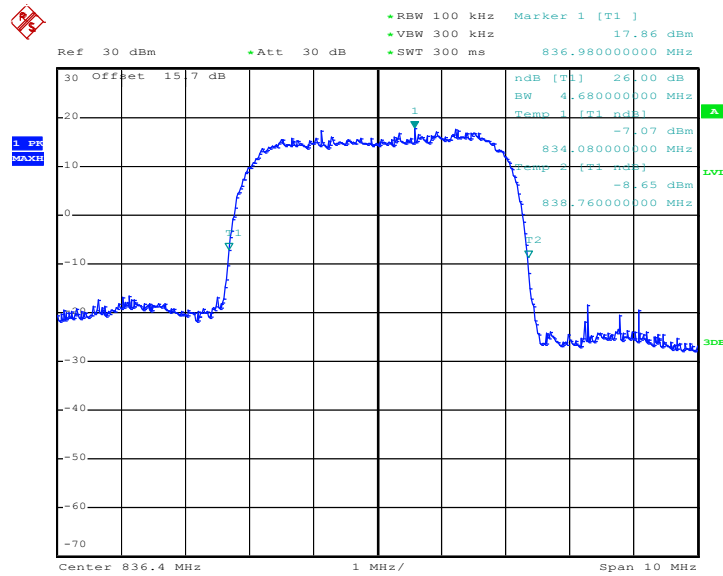

Date: 29.MAY.2012 01:26:35



99% Occupied Bandwidth Plot on Channel 4233

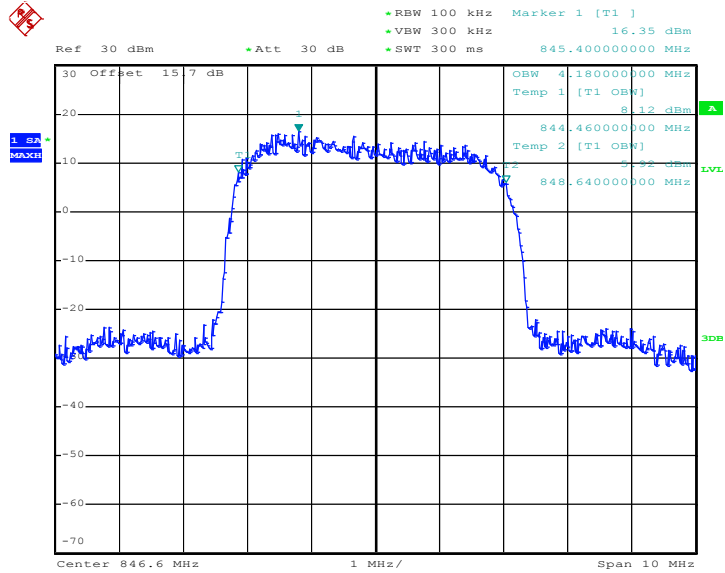

Date: 29.MAY.2012 01:28:20

26dB Bandwidth Plot on Channel 4233

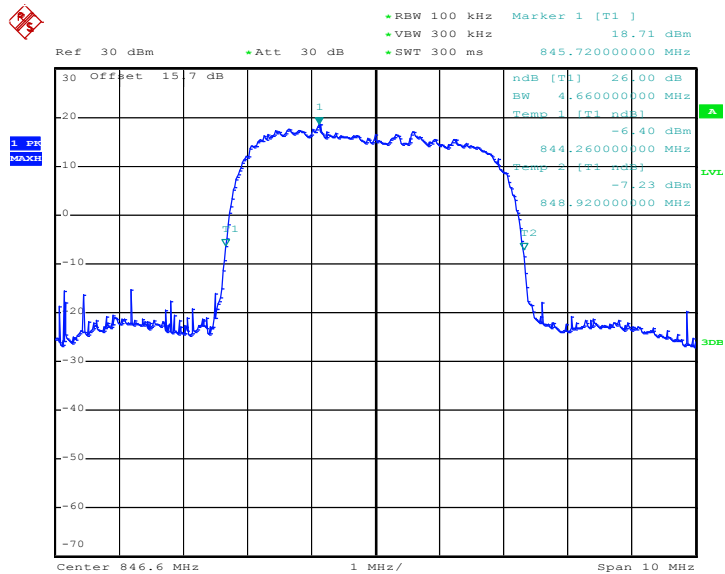

Date: 29.MAY.2012 01:27:01



Band :	WCDMA Band II	Power Stage :	High
Test Mode :	RMC 12.2Kbps Link		

99% Occupied Bandwidth Plot on Channel 9262

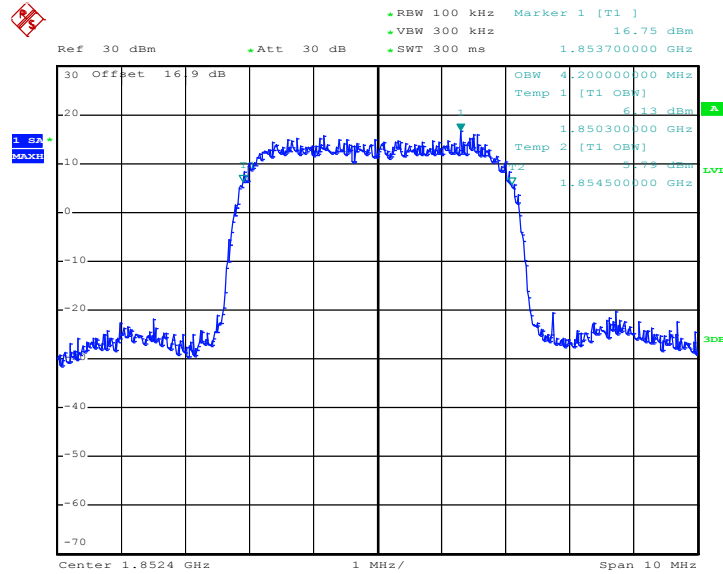

Date: 29.MAY.2012 01:17:33

26dB Bandwidth Plot on Channel 9262

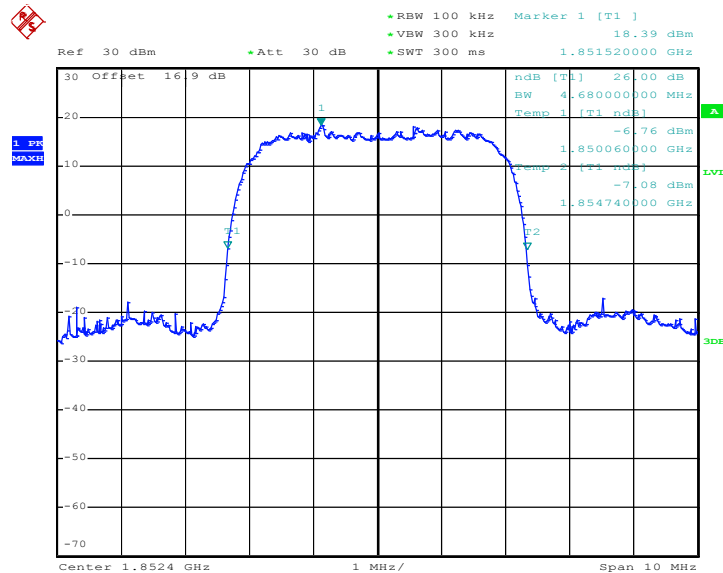

Date: 29.MAY.2012 01:16:15



99% Occupied Bandwidth Plot on Channel 9400

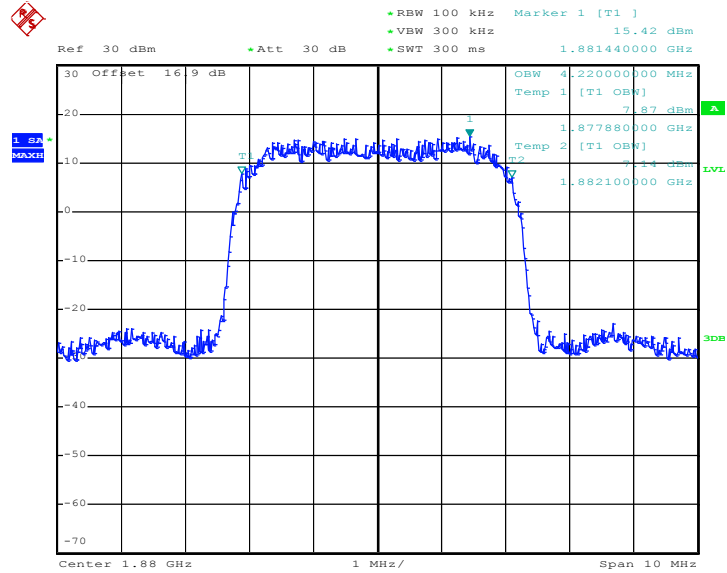

Date: 29.MAY.2012 01:17:59

26dB Bandwidth Plot on Channel 9400

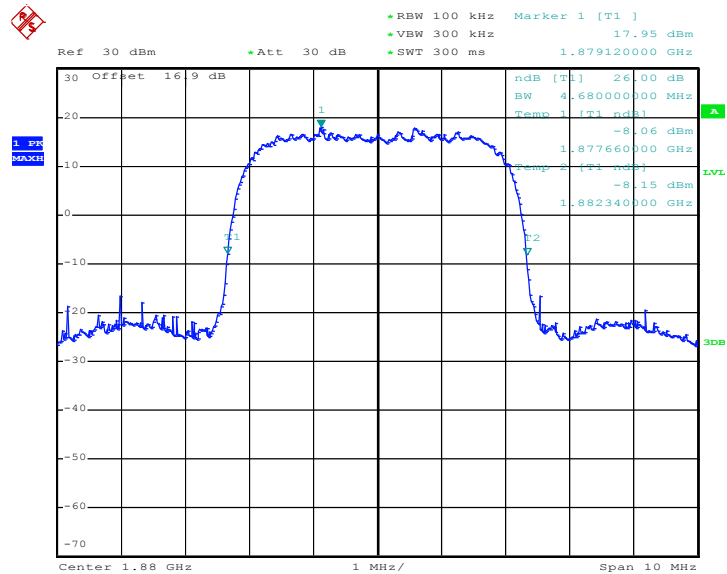

Date: 29.MAY.2012 01:16:41



99% Occupied Bandwidth Plot on Channel 9538

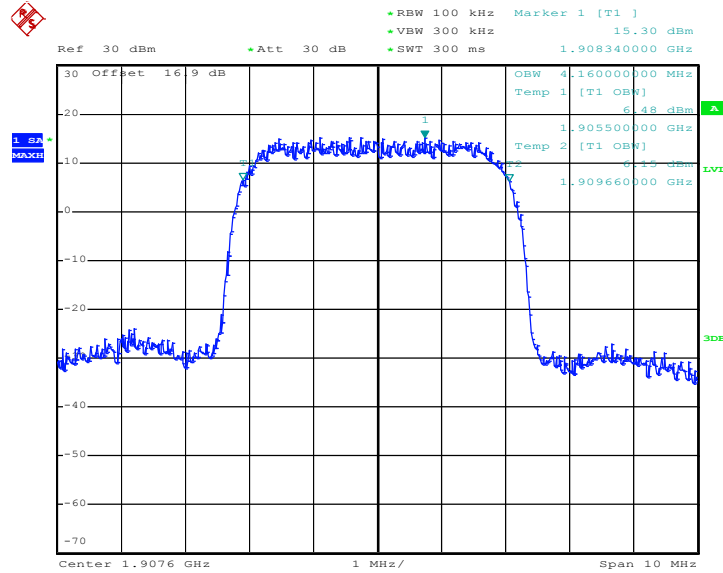

Date: 29.MAY.2012 01:18:25

26dB Bandwidth Plot on Channel 9538

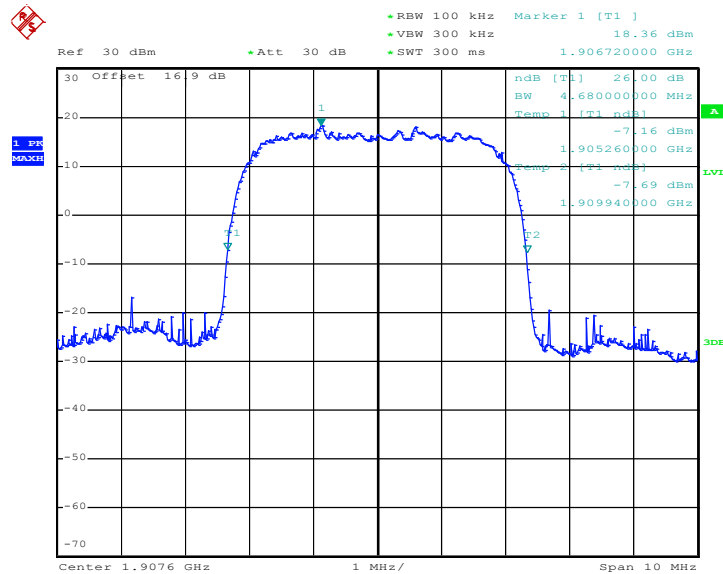

Date: 29.MAY.2012 01:17:07

3.4 Band Edge Measurement

3.4.1 Description of Band Edge Measurement

The power of any emission outside of the authorized operating frequency ranges must be lower than the transmitter power (P) by a factor of at least $43 + 10 \log (P)$ dB.

3.4.2 Measuring Instruments

See list of measuring instruments of this test report.

3.4.3 Test Procedures

1. The EUT was connected to Spectrum Analyzer and Base Station via power divider.
2. The band edges of low and high channels for the highest RF powers were measured. Setting RBW as roughly $BW/100$.

3.4.4 Test Setup

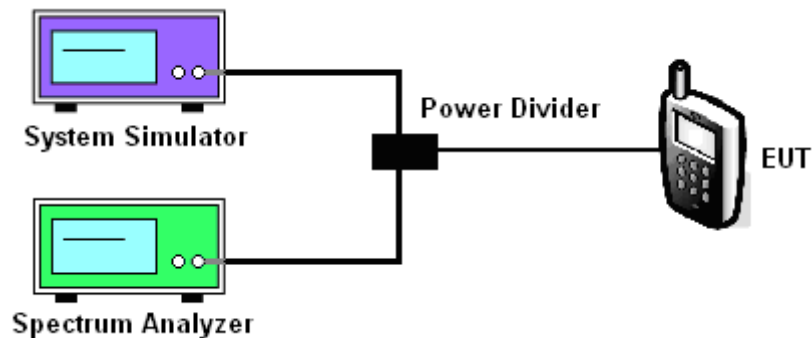

3.4.5 Test Result (Plots) of Conducted Band Edge

Band :	GSM850	Power Stage :	High
Test Mode :	GSM Link	Maximum 26dB Bandwidth :	0.316MHz
Correction Factor :	0.23dB	Measurement Value :	-19.39dBm
Band Edge :	-19.16dBm		

Lower Band Edge Plot on Channel 128

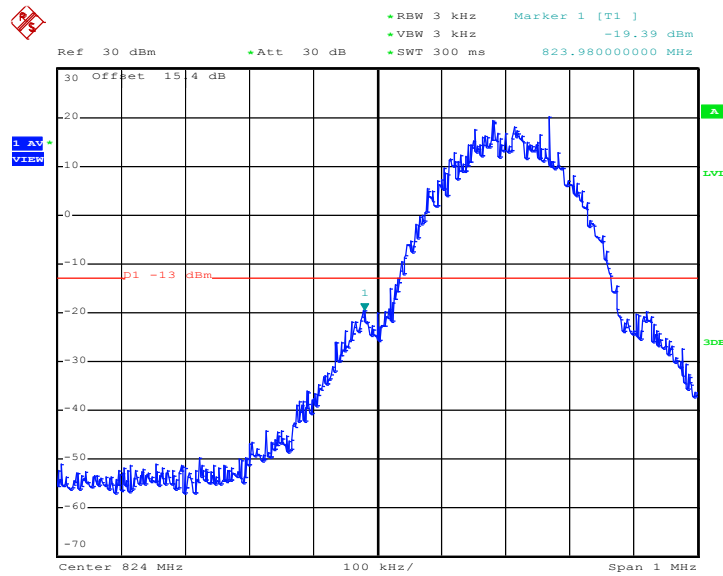

Date: 8.JUN.2012 09:27:27

1. Correction Factor(dB)= $10\log(1\% \text{ Emission BW/RBW})$
2. Band Edge= Measurement Value + Correction Factor(dB)



Band :	GSM850	Power Stage :	High
Test Mode :	GSM Link	Maximum 26dB Bandwidth :	0.316MHz
Correction Factor :	0.23dB	Measurement Value :	-17.03dBm
Band Edge :	-16.80dBm		

Higher Band Edge Plot on Channel 251

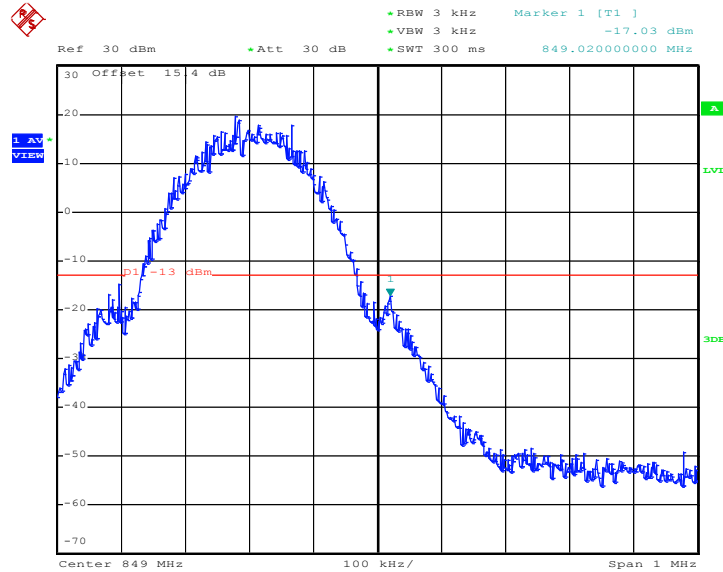

Date: 8.JUN.2012 09:27:53

1. Correction Factor(dB)= $10\log(1\% \text{ Emission BW/RBW})$
2. Band Edge= Measurement Value + Correction Factor(dB)



Band :	GSM850	Power Stage :	High
Test Mode :	EDGE 8 Link	Maximum 26dB Bandwidth :	0.316MHz
Correction Factor :	0.23dB	Measurement Value :	-25.00dBm
Band Edge :	-24.77dBm		

Lower Band Edge Plot on Channel 128

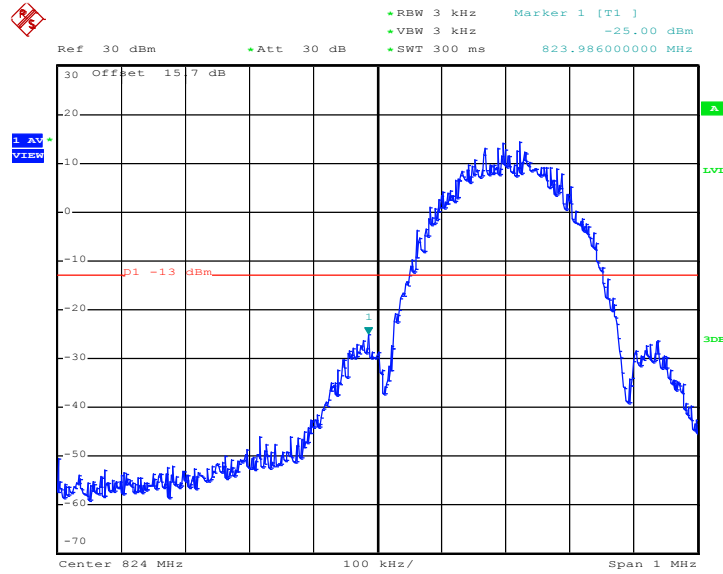

Date: 29.MAY.2012 01:04:34

1. Correction Factor(dB)= $10\log(1\% \text{ Emission BW/RBW})$
2. Band Edge= Measurement Value + Correction Factor(dB)



Band :	GSM850	Power Stage :	High
Test Mode :	EDGE 8 Link	Maximum 26dB Bandwidth :	0.316MHz
Correction Factor :	0.23dB	Measurement Value :	-26.78dBm
Band Edge :	-26.55dBm		

Higher Band Edge Plot on Channel 251

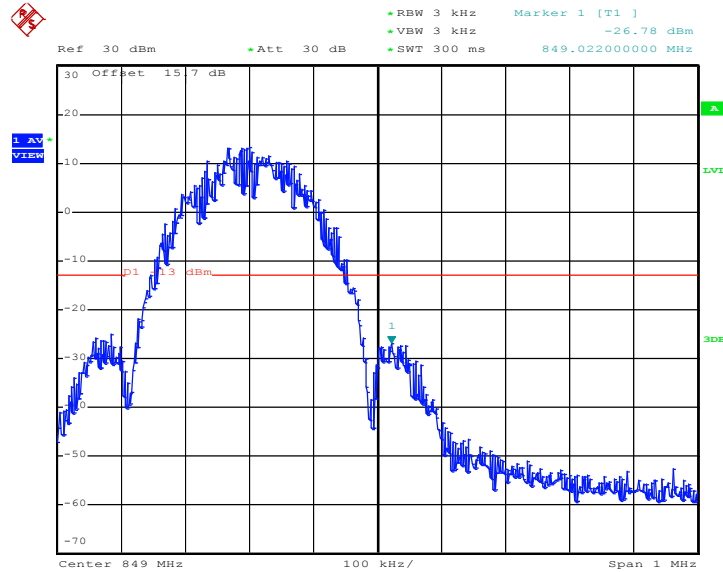

Date: 29.MAY.2012 01:05:00

1. Correction Factor(dB)= $10\log(1\% \text{ Emission BW/RBW})$
2. Band Edge= Measurement Value + Correction Factor(dB)



Band :	GSM1900	Power Stage :	High
Test Mode :	GSM Link	Maximum 26dB Bandwidth :	0.316MHz
Correction Factor :	0.23dB	Measurement Value :	-19.38dBm
Band Edge :	-19.15dBm		

Lower Band Edge Plot on Channel 512

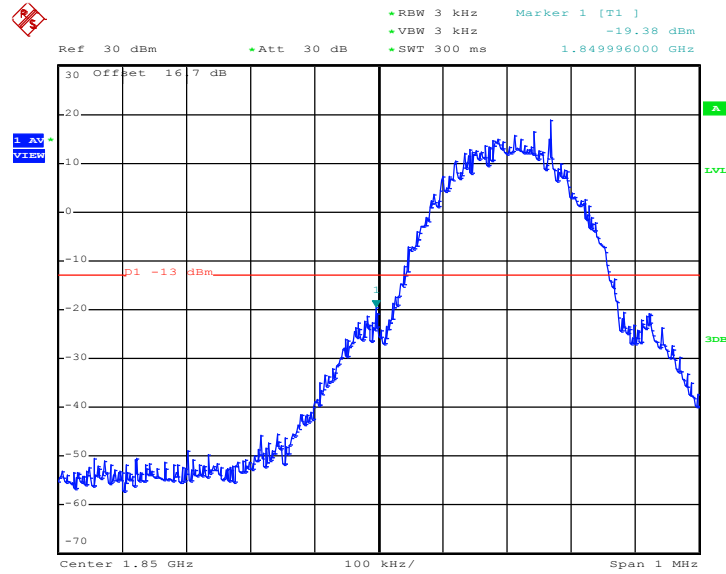

Date: 9.JUN.2012 00:02:51

1. Correction Factor(dB)= $10\log(1\% \text{ Emission BW/RBW})$
2. Band Edge= Measurement Value + Correction Factor(dB)



Band :	GSM1900	Power Stage :	High
Test Mode :	GSM Link	Maximum 26dB Bandwidth :	0.316MHz
Correction Factor :	0.23dB	Measurement Value :	-22.19dBm
Band Edge :	-21.96dBm		

Higher Band Edge Plot on Channel 810

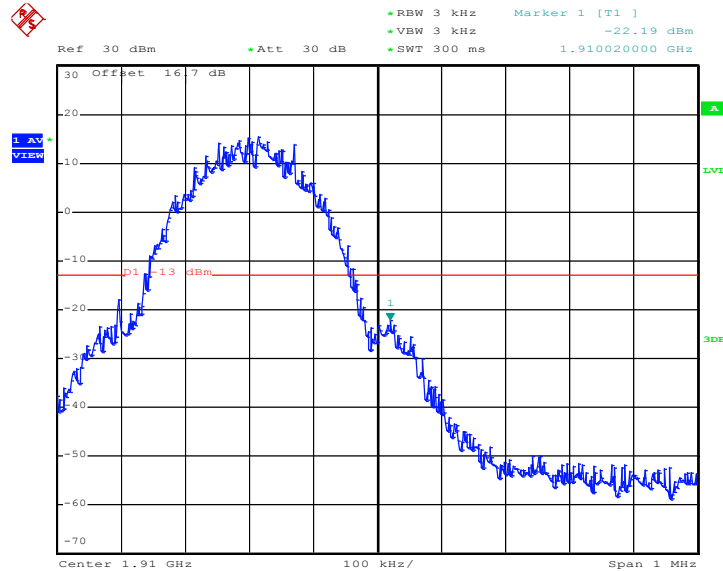

Date: 8.JUN.2012 10:03:34

1. Correction Factor(dB)= $10\log(1\% \text{ Emission BW/RBW})$
2. Band Edge= Measurement Value + Correction Factor(dB)



Band :	GSM1900	Power Stage :	High
Test Mode :	EDGE 8 Link	Maximum 26dB Bandwidth :	0.300MHz
Correction Factor :	0.00dB	Measurement Value :	-24.77dBm
Band Edge :	-24.77dBm		

Lower Band Edge Plot on Channel 512

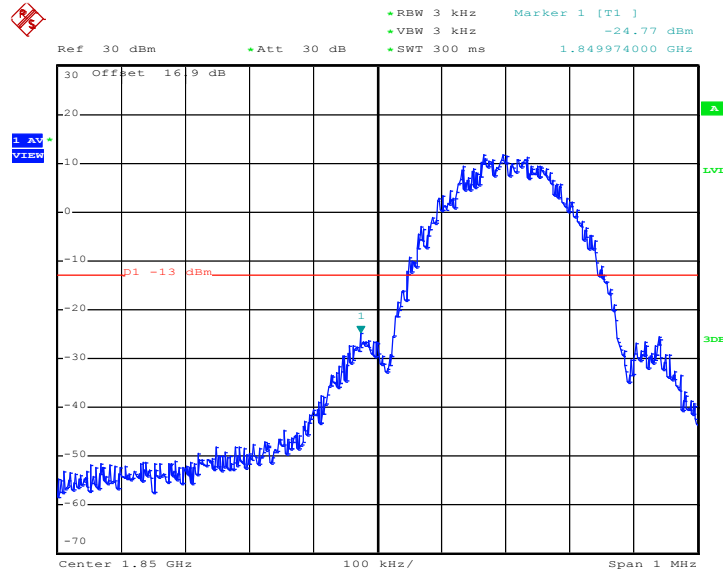

Date: 29.MAY.2012 00:50:43

1. Correction Factor(dB)= $10\log(1\% \text{ Emission BW/RBW})$
2. Band Edge= Measurement Value + Correction Factor(dB)



Band :	GSM1900	Power Stage :	High
Test Mode :	EDGE 8 Link	Maximum 26dB Bandwidth :	0.300MHz
Correction Factor :	0.00dB	Measurement Value :	-26.39dBm
Band Edge :	-26.39dBm		

Higher Band Edge Plot on Channel 810

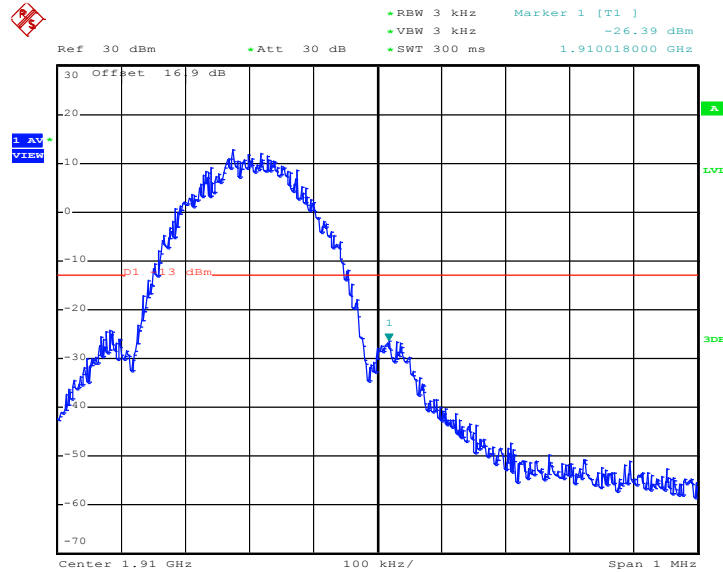

Date: 29.MAY.2012 00:47:08

1. Correction Factor(dB)= $10\log(1\% \text{ Emission BW/RBW})$
2. Band Edge= Measurement Value + Correction Factor(dB)



Band :	WCDMA Band V	Power Stage :	High
Test Mode :	RMC 12.2Kbps Link	Maximum 26dB Bandwidth :	4.680MHz
Correction Factor :	-3.30dB	Measurement Value :	-26.85dBm
Band Edge :	-30.15dBm		

Lower Band Edge Plot on Channel 4132

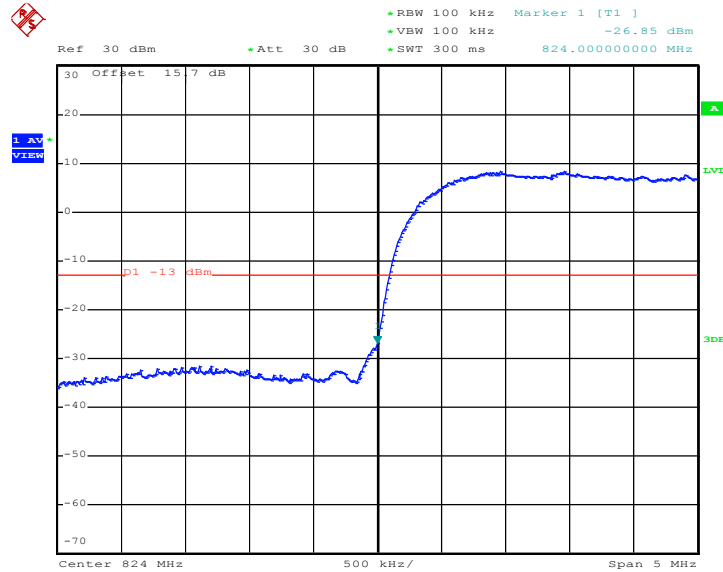

Date: 29.MAY.2012 01:29:48

1. Correction Factor(dB)= $10\log(1\% \text{ Emission BW/RBW})$
2. Band Edge= Measurement Value + Correction Factor(dB)



Band :	WCDMA Band V	Power Stage :	High
Test Mode :	RMC 12.2Kbps Link	Maximum 26dB Bandwidth :	4.680MHz
Correction Factor :	-3.30dB	Measurement Value :	-28.08dBm
Band Edge :	-31.38dBm		

Higher Band Edge Plot on Channel 4233

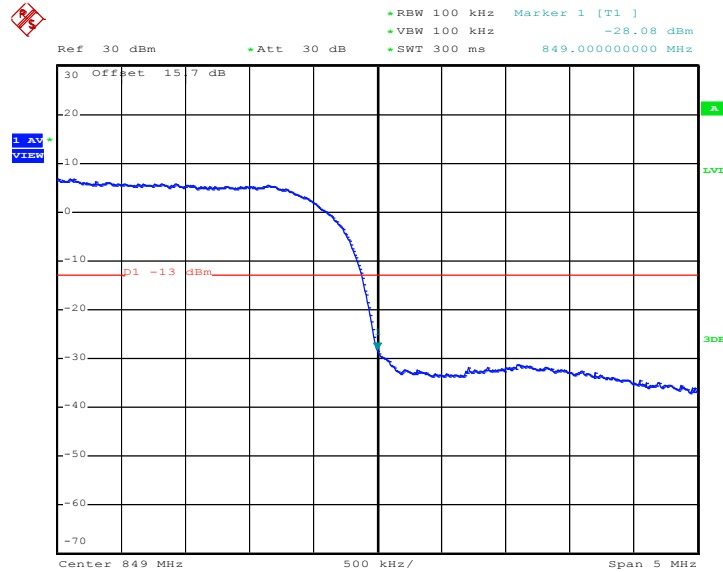

Date: 29.MAY.2012 01:30:14

1. Correction Factor(dB)= 10log(1% Emission BW/RBW)
2. Band Edge= Measurement Value + Correction Factor(dB)



Band :	WCDMA Band II	Power Stage :	High
Test Mode :	RMC 12.2Kbps Link	Maximum 26dB Bandwidth :	4.680MHz
Correction Factor :	-3.30dB	Measurement Value :	-26.74dBm
Band Edge :	-30.04dBm		

Lower Band Edge Plot on Channel 9262

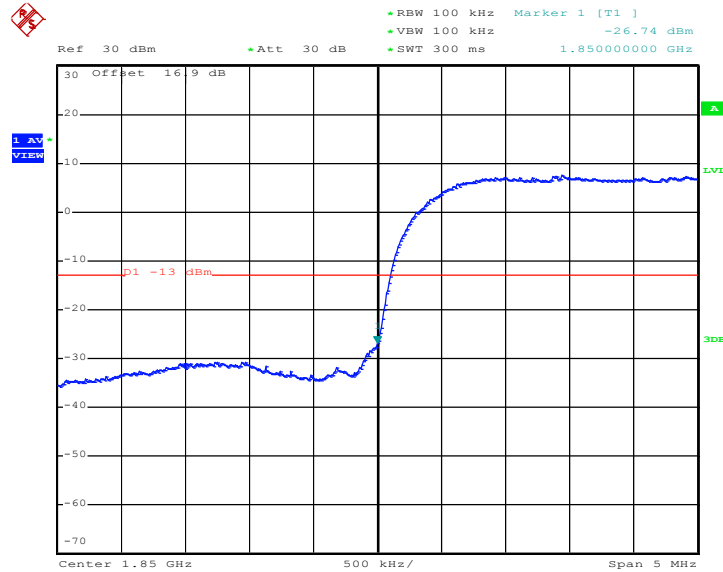

Date: 29.MAY.2012 01:19:53

1. Correction Factor(dB)= $10\log(1\% \text{ Emission BW/RBW})$
2. Band Edge= Measurement Value + Correction Factor(dB)



Band :	WCDMA Band II	Power Stage :	High
Test Mode :	RMC 12.2Kbps Link	Maximum 26dB Bandwidth :	4.680MHz
Correction Factor :	-3.30dB	Measurement Value :	-27.68dBm
Band Edge :	-30.98dBm		

Higher Band Edge Plot on Channel 9538

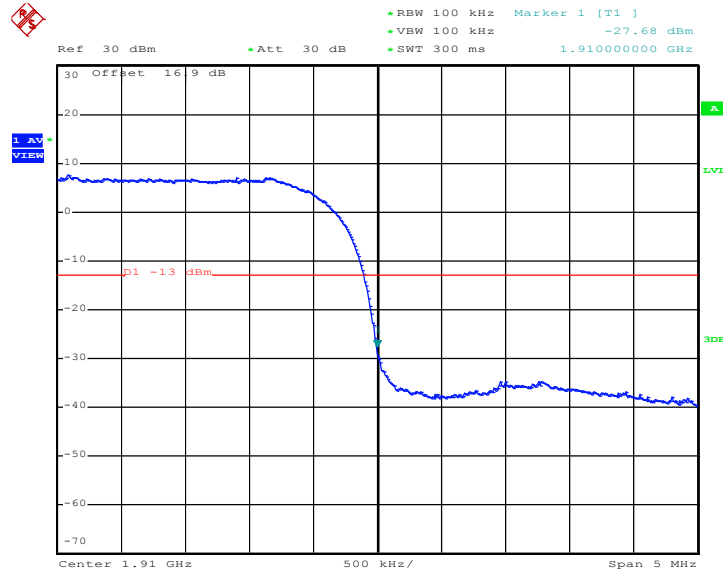

Date: 29.MAY.2012 01:20:20

1. Correction Factor(dB)= $10\log(1\% \text{ Emission BW/RBW})$
2. Band Edge= Measurement Value + Correction Factor(dB)

3.5 Conducted Emission Measurement

3.5.1 Description of Conducted Emission Measurement

The power of any emission outside of the authorized operating frequency ranges must be lower than the transmitter power (P) by a factor of at least $43 + 10 \log (P)$ dB.

It is measured by means of a calibrated spectrum analyzer and scanned from 30 MHz up to a frequency including its 10th harmonic.

3.5.2 Measuring Instruments

See list of measuring instruments of this test report.

3.5.3 Test Procedures

1. The EUT was connected to spectrum analyzer and base station via power divider.
2. The middle channel for the highest RF power within the transmitting frequency was measured.
3. The conducted spurious emission for the whole frequency range was taken.

3.5.4 Test Setup

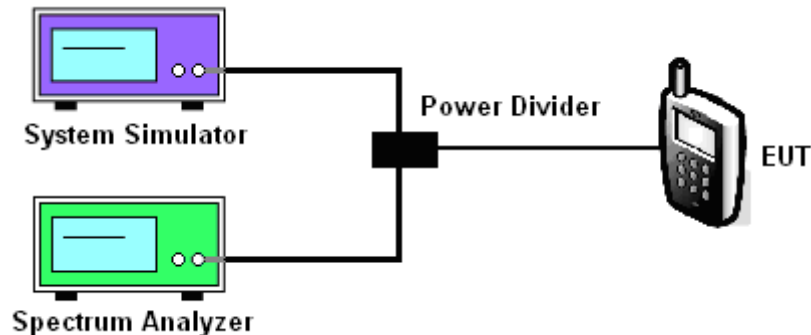

3.5.5 Test Result (Plots) of Conducted Emission

Band :	GSM850	Channel :	CH189
Test Mode :	GSM Link		

Conducted Emission Plot between 30MHz ~ 1GHz

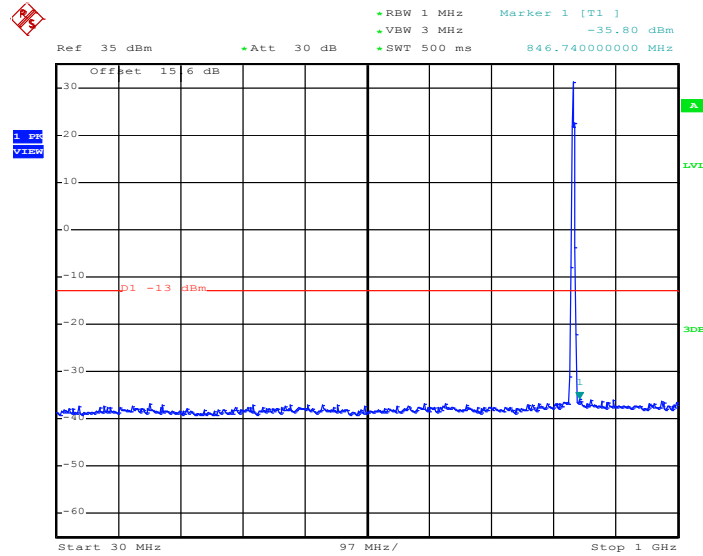

Date: 8.JUN.2012 23:52:59

Conducted Emission Plot between 1GHz ~ 3GHz

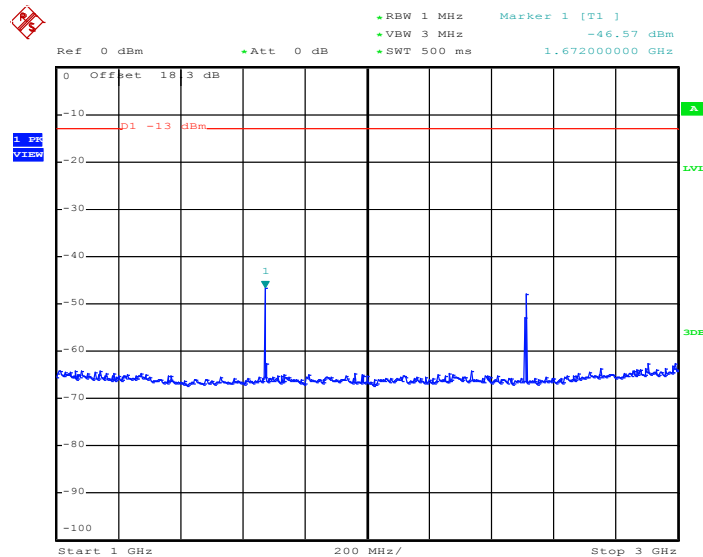

Date: 8.JUN.2012 23:53:25



Band :	GSM850	Channel :	CH189
Test Mode :	EDGE 8 Link		

Conducted Emission Plot between 30MHz ~ 1GHz

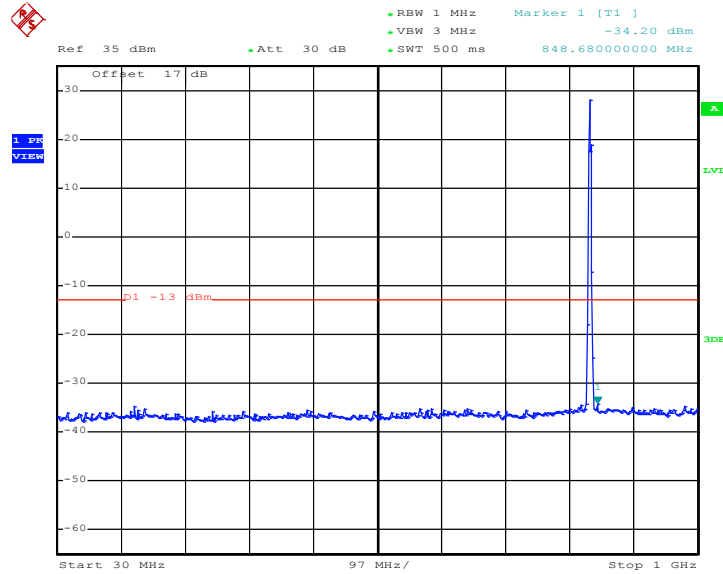

Date: 29.MAY.2012 00:59:17

Conducted Emission Plot between 1GHz ~ 3GHz

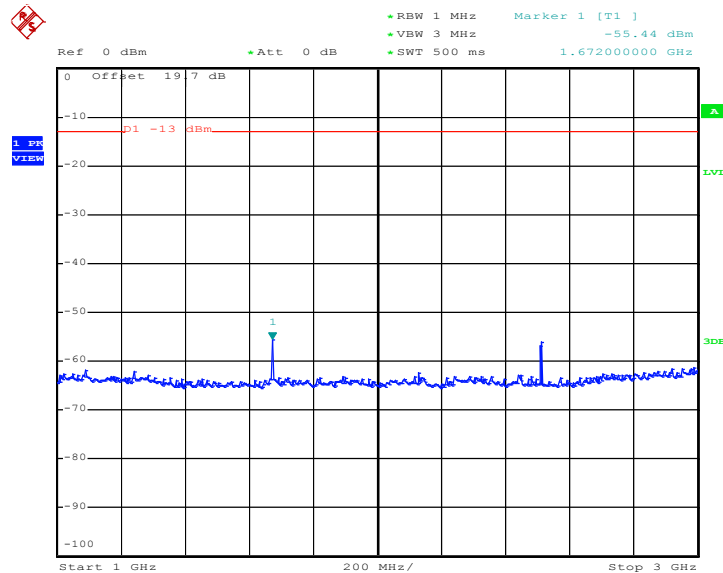

Date: 29.MAY.2012 00:59:49



Conducted Emission Plot between 3GHz ~ 7GHz

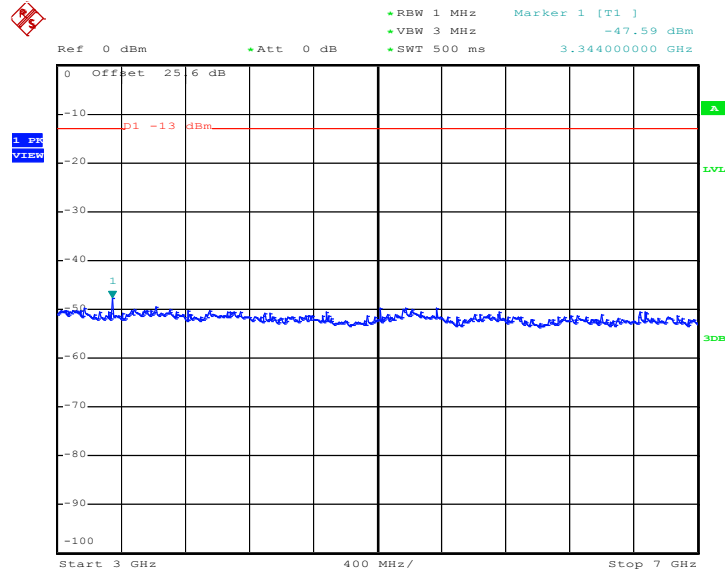

Date: 29.MAY.2012 01:00:02

Conducted Emission Plot between 7GHz ~ 9GHz

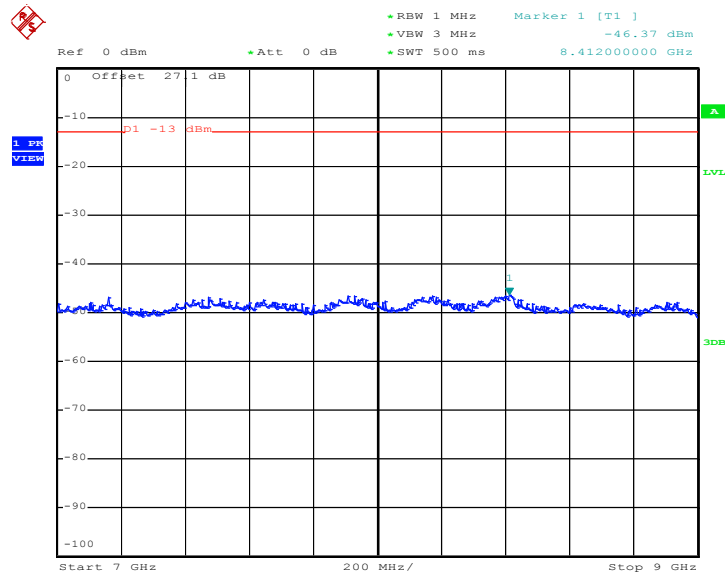

Date: 29.MAY.2012 01:00:14



Band :	GSM1900	Channel :	CH661
Test Mode :	GSM Link		

Conducted Emission Plot between 30MHz ~ 1GHz

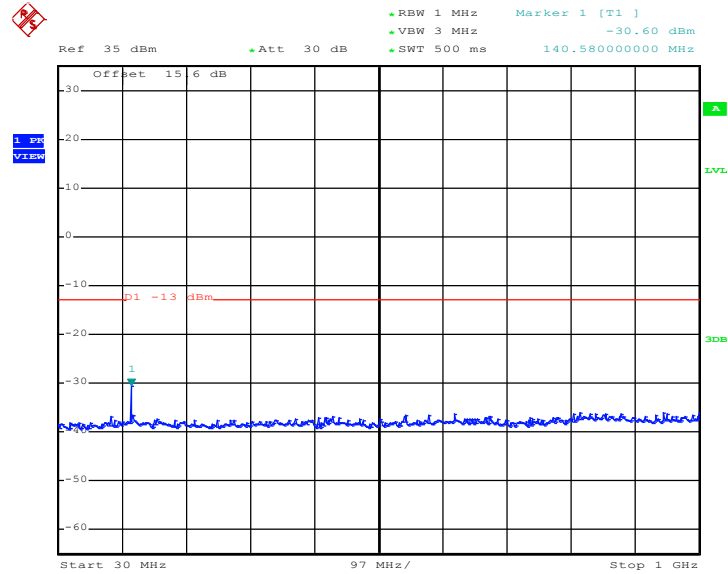

Date: 8.JUN.2012 23:55:20

Conducted Emission Plot between 1GHz ~ 3GHz

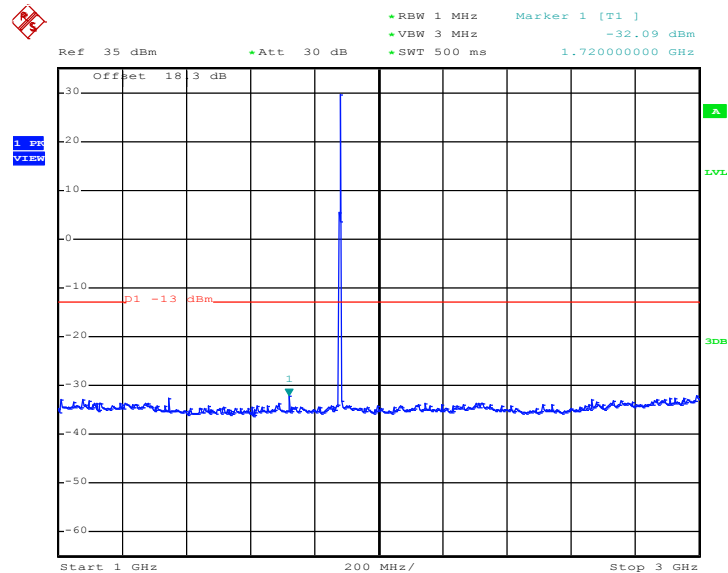

Date: 8.JUN.2012 23:55:32



Conducted Emission Plot between 3GHz ~ 7GHz

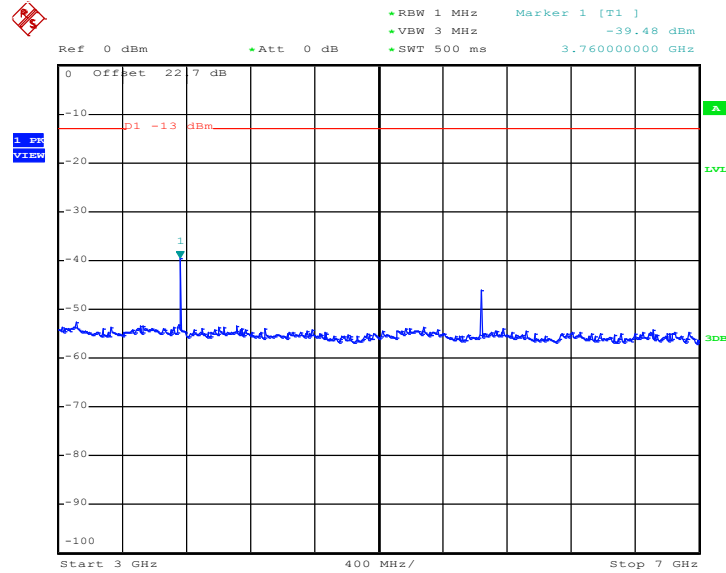

Date: 8.JUN.2012 23:56:00

Conducted Emission Plot between 7GHz ~ 13.6GHz

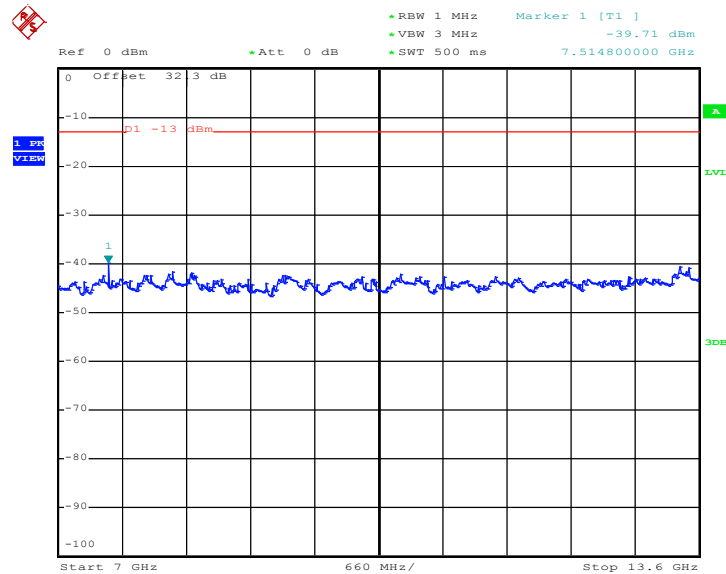

Date: 8.JUN.2012 23:56:12



Conducted Emission Plot between 13.6GHz ~ 19.1GHz

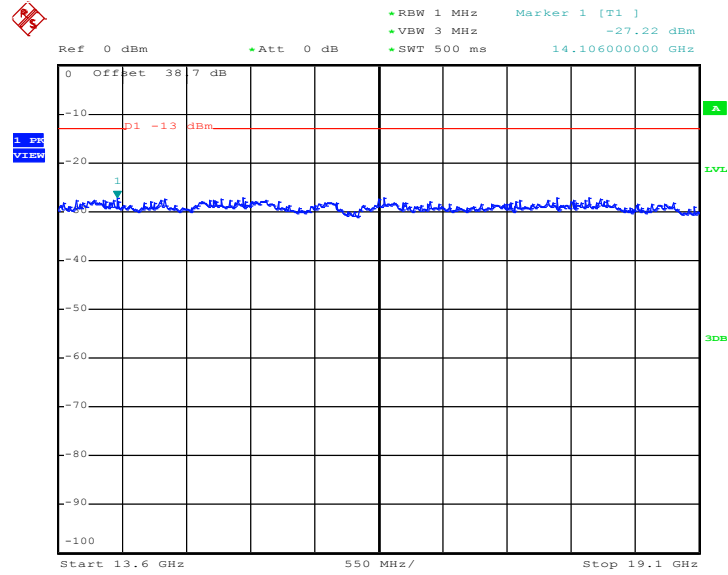

Date: 8.JUN.2012 23:56:25



Band :	GSM1900	Channel :	CH661
Test Mode :	EDGE 8 Link		

Conducted Emission Plot between 30MHz ~ 1GHz

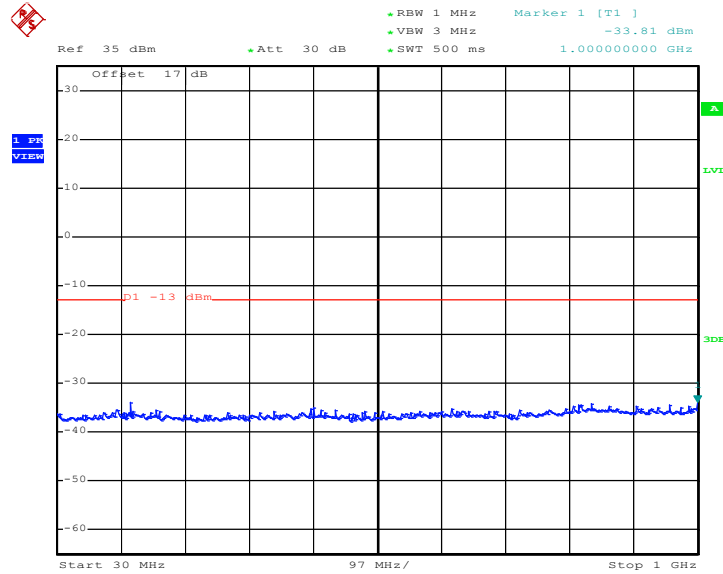

Date: 29.MAY.2012 00:40:28

Conducted Emission Plot between 1GHz ~ 3GHz

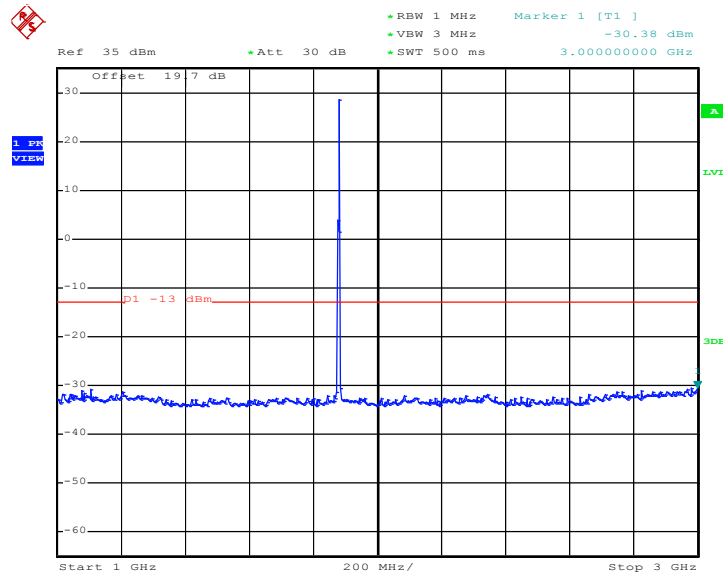

Date: 29.MAY.2012 00:40:40



Conducted Emission Plot between 3GHz ~ 7GHz

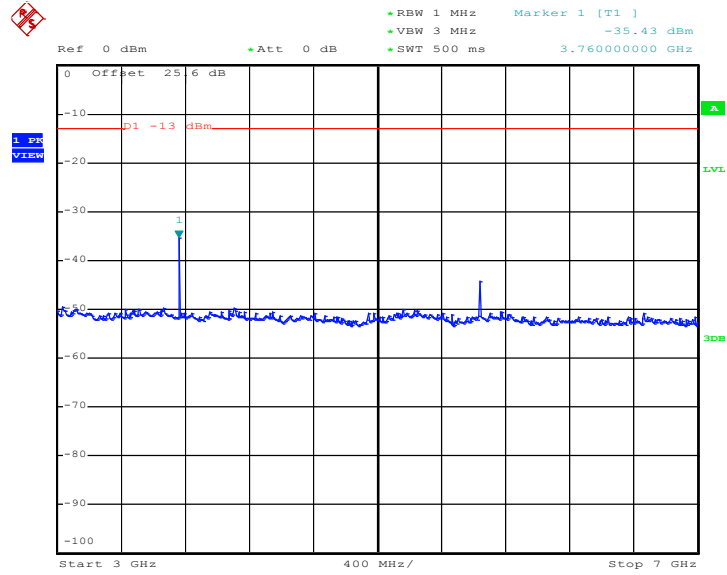

Date: 29.MAY.2012 00:42:01

Conducted Emission Plot between 7GHz ~ 13.6GHz

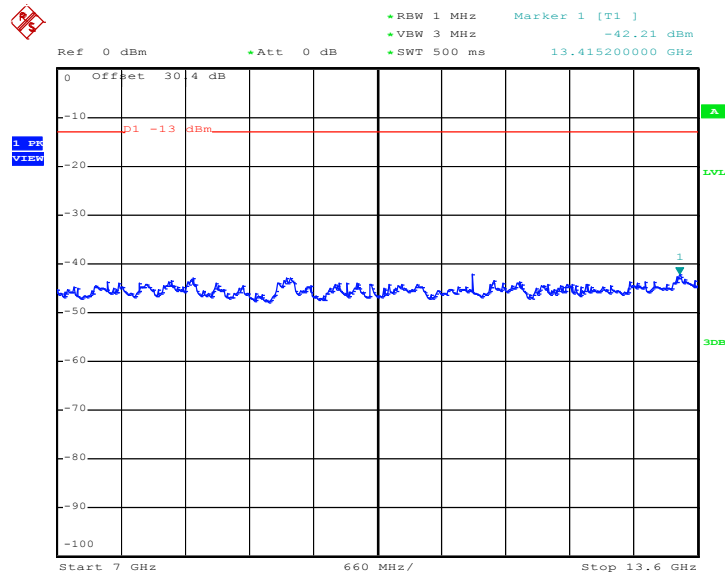

Date: 29.MAY.2012 00:42:13



Conducted Emission Plot between 13.6GHz ~ 19.1GHz

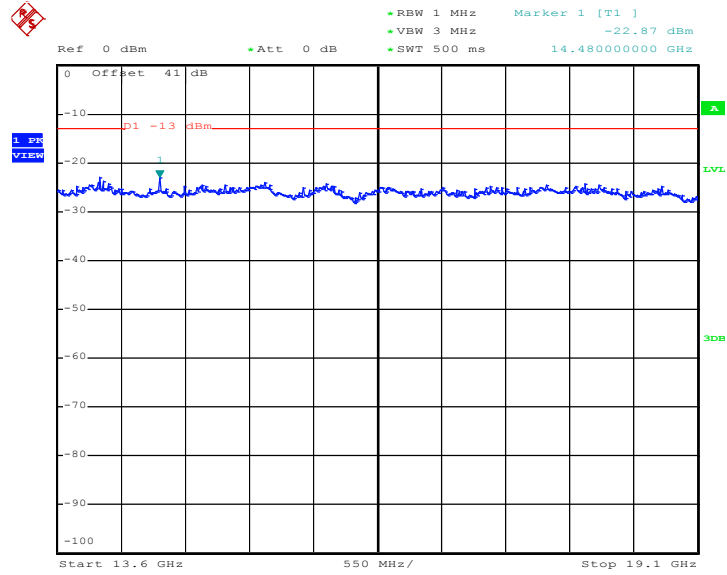

Date: 29.MAY.2012 00:42:26



Band :	WCDMA Band V	Channel :	CH4182
Test Mode :	RMC 12.2Kbps Link		

Conducted Emission Plot between 30MHz ~ 1GHz

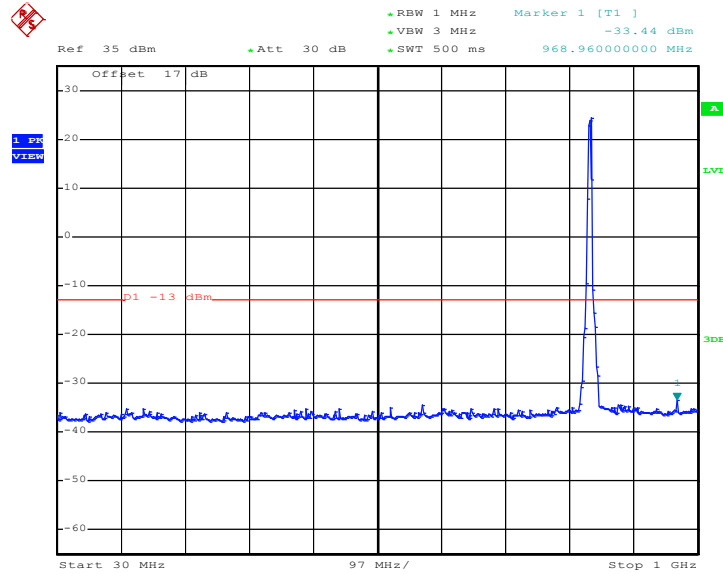

Date: 29.MAY.2012 01:24:43

Conducted Emission Plot between 1GHz ~ 3GHz

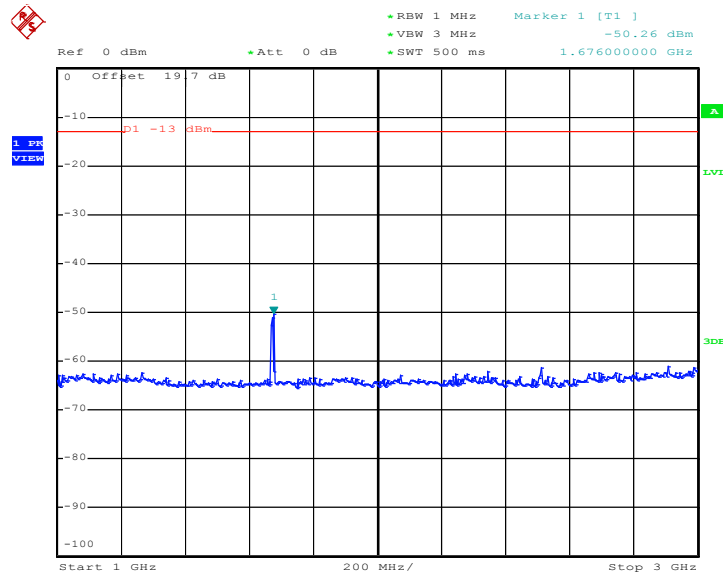

Date: 29.MAY.2012 01:25:01



Conducted Emission Plot between 3GHz ~ 7GHz

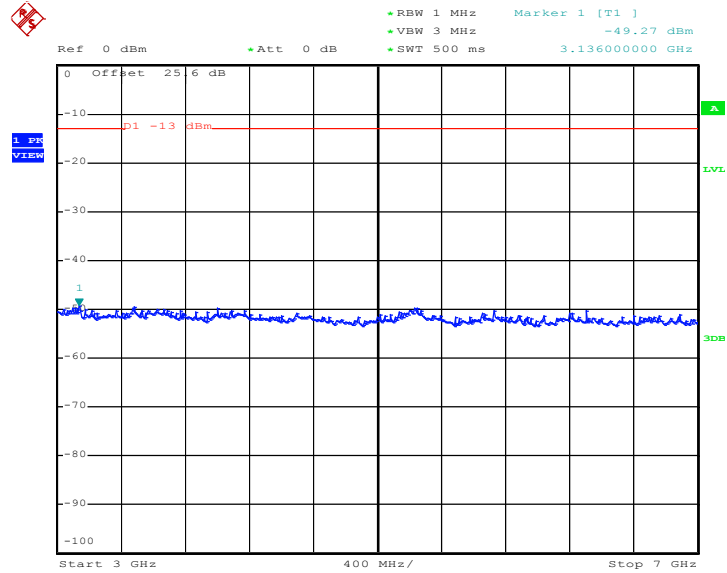

Date: 29.MAY.2012 01:25:14

Conducted Emission Plot between 7GHz ~ 9GHz

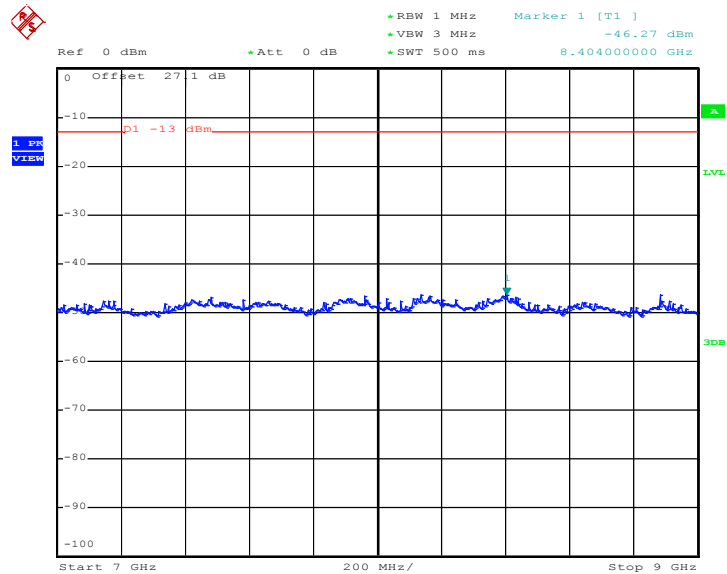

Date: 29.MAY.2012 01:25:26



Band :	WCDMA Band II	Channel :	CH9400
Test Mode :	RMC 12.2Kbps Link		

Conducted Emission Plot between 30MHz ~ 1GHz

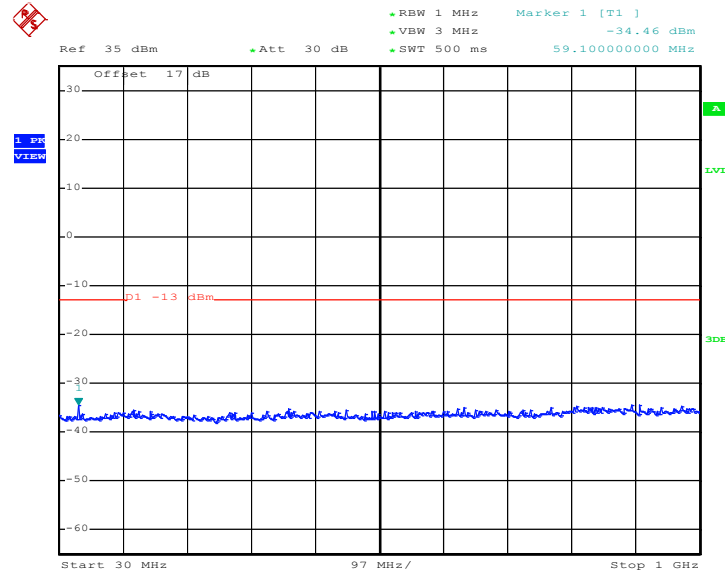

Date: 29.MAY.2012 01:13:28

Conducted Emission Plot between 1GHz ~ 3GHz

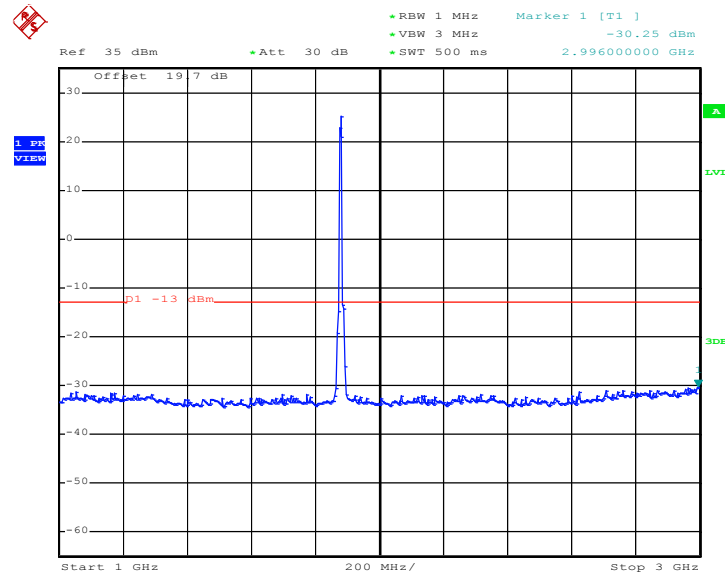

Date: 29.MAY.2012 01:13:40



Conducted Emission Plot between 3GHz ~ 7GHz

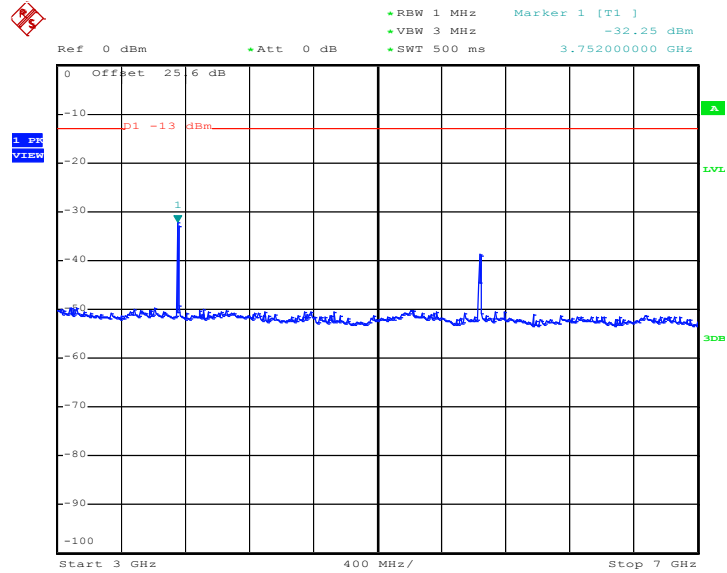

Date: 29.MAY.2012 01:13:59

Conducted Emission Plot between 7GHz ~ 13.6GHz

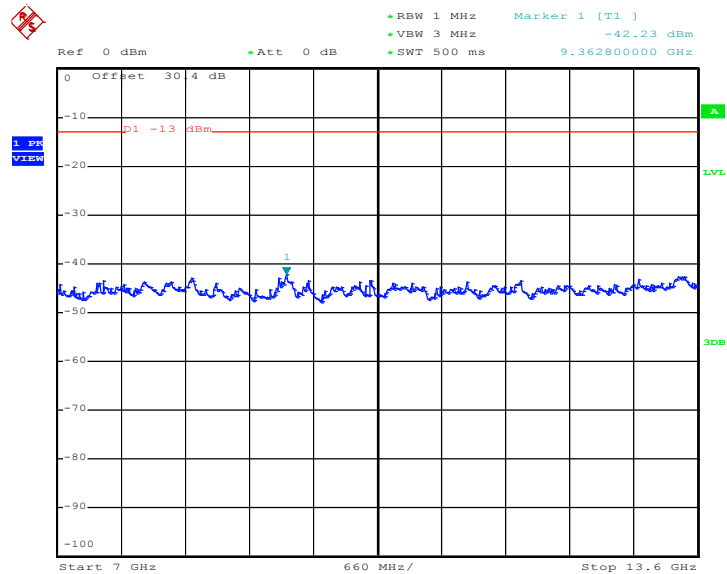

Date: 29.MAY.2012 01:14:11



Conducted Emission Plot between 13.6GHz ~ 19.1GHz

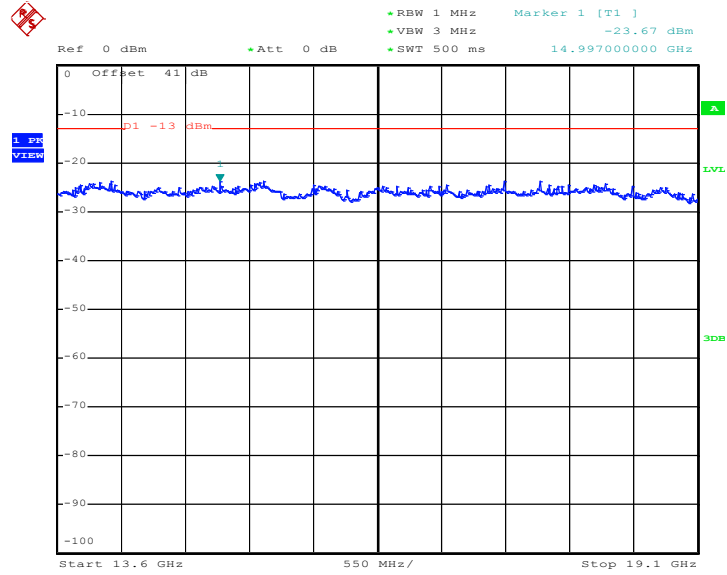

Date: 29.MAY.2012 01:14:23

3.6 Field Strength of Spurious Radiation Measurement

3.6.1 Description of Field Strength of Spurious Radiated Measurement

The radiated spurious emission was measured by substitution method according to ANSI / TIA / EIA-603-C-2004. The power of any emission outside of the authorized operating frequency ranges must be attenuated below the transmitter power (P) by a factor of at least $43 + 10 \log (P)$ dB. The spectrum is scanned from 30 MHz up to a frequency including its 10th harmonic.

3.6.2 Measuring Instruments

See list of measuring instruments of this test report.

3.6.3 Test Procedures

4. The EUT was placed on a rotatable wooden table with 0.8 meter about ground.
5. The EUT was set 3 meters from the receiving antenna, which was mounted on the antenna tower.
6. The table was rotated 360 degrees to determine the position of the highest spurious emission.
7. The height of the receiving antenna is varied between one meter and four meters to search the maximum spurious emission for both horizontal and vertical polarizations.
8. Make the measurement with the spectrum analyzer's RBW = 1MHz, VBW = 3MHz, Sweep = 500ms, Taking the record of maximum spurious emission.
9. A horn antenna was substituted in place of the EUT and was driven by a signal generator.
10. Tune the output power of signal generator to the same emission level with EUT maximum spurious emission.
11. Taking the record of output power at antenna port.
12. Repeat step 7 to step 8 for another polarization.
13. $EIRP \text{ (dBm)} = S.G. \text{ Power} - Tx \text{ Cable Loss} + Tx \text{ Antenna Gain}$
14. $ERP \text{ (dBm)} = EIRP - 2.15$

3.6.4 Test Setup

For radiated emissions below 30MHz

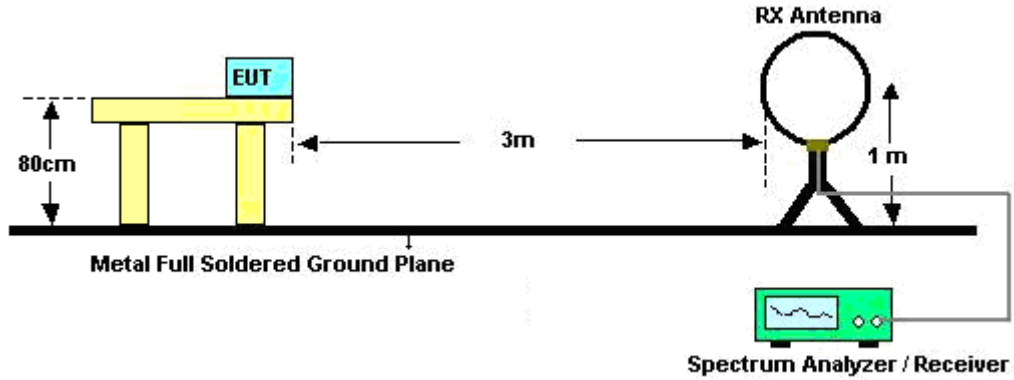

For radiated emissions from 30MHz to 1GHz

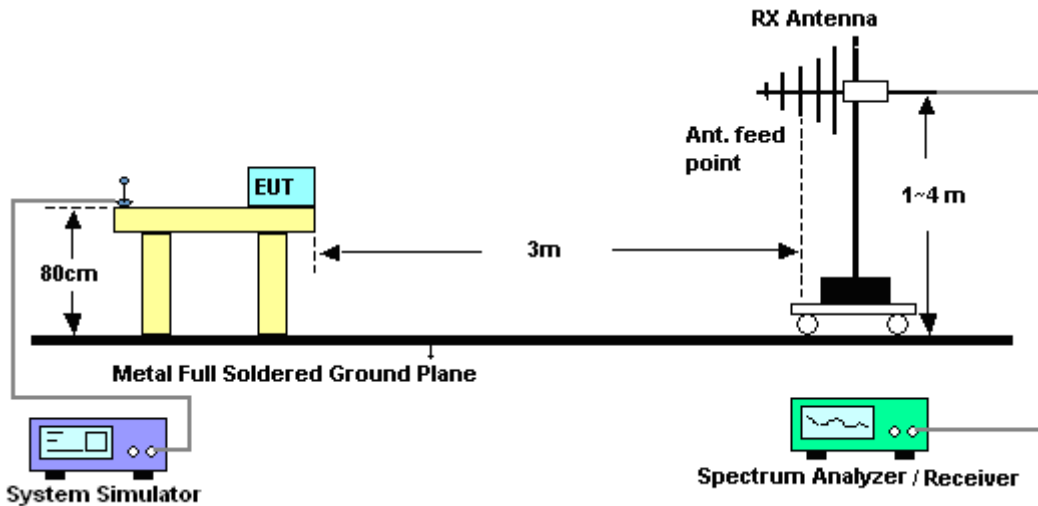

For radiated emissions above 1GHz

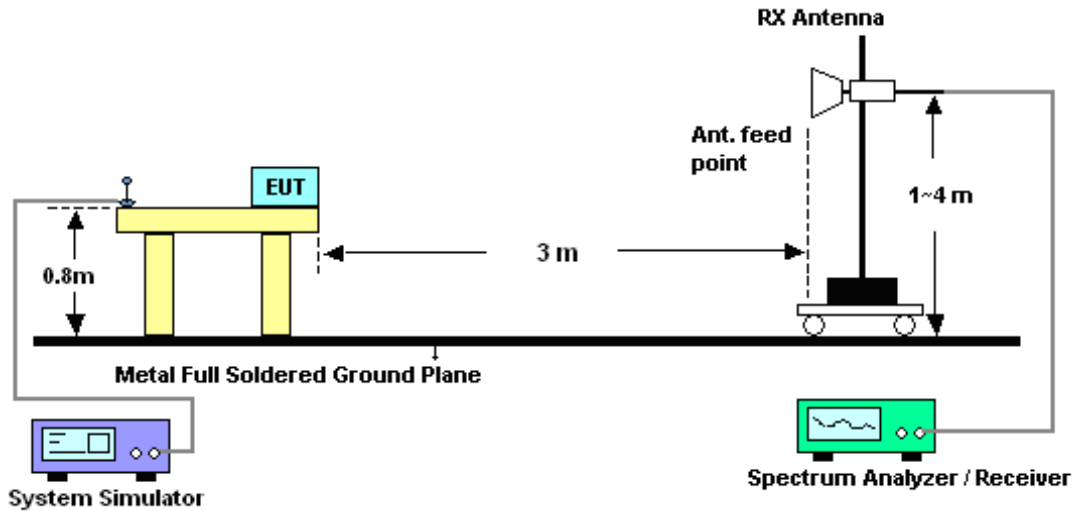

3.6.5 Test Results of Radiated Emissions (9 KHz ~ 30 MHz)

The low frequency, which started from 9 KHz to 30MHz, was pre-scanned and the result which was 20dB lower than the limit line per 15.31(o) was not reported.



3.6.6 Test Result of Field Strength of Spurious Radiated

Band :	GSM850	Temperature :	23~24°C
Test Mode :	GSM Link	Relative Humidity :	51~53%
Test Engineer :	David Yang	Polarization :	Horizontal
Remark :	Spurious emissions within 30-1000MHz were found more than 20dB below limit line.		

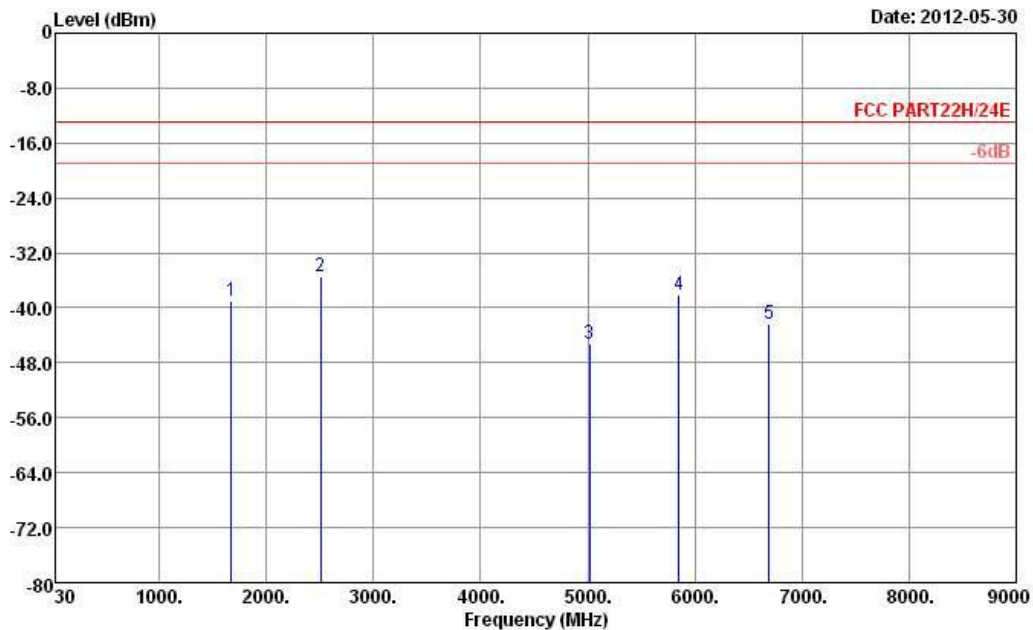

Site : 03CH05-HY
 Condition : FCC PART22H/24E HF_EIRP_101221 HORIZONTAL
 RBW:1000.000KHz VBW:3000.000KHz
 Project : FG 252201

Frequency (MHz)	ERP (dBm)	Limit (dBm)	Over Limit (dB)	SPA Reading (dBm)	S.G. Power (dBm)	TX Cable loss (dB)	TX Antenna Gain (dBi)	Polarization (H/V)	Result
1672	-39.01	-13	-26.01	-45.1	-40.2	2.15	5.49	H	Pass
2509	-35.51	-13	-22.51	-44.9	-37.4	2.38	6.41	H	Pass
5018	-45.26	-13	-32.26	-62.62	-50	3.62	10.51	H	Pass
5854	-38.03	-13	-25.03	-57.25	-42.8	3.95	10.87	H	Pass
6691	-42.38	-13	-29.38	-63.64	-47.2	4.36	11.33	H	Pass



Band :	GSM850	Temperature :	23~24°C
Test Mode :	GSM Link	Relative Humidity :	51~53%
Test Engineer :	David Yang	Polarization :	Vertical
Remark :	Spurious emissions within 30-1000MHz were found more than 20dB below limit line.		

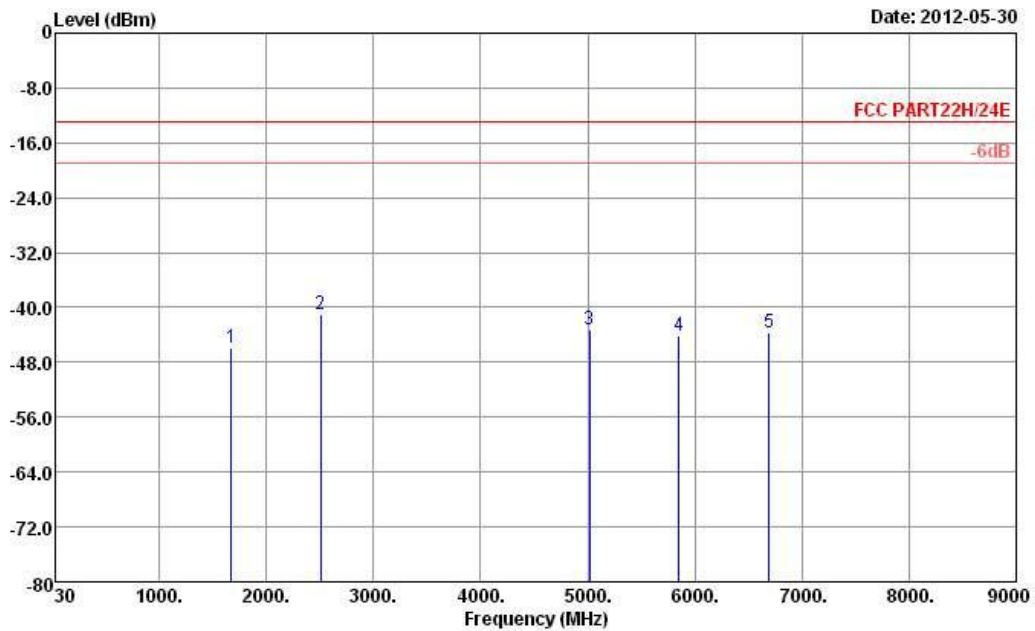

Site : 03CH05-HY
 Condition : FCC PART22H/24E HF_EIRP_101221 VERTICAL
 RBW:1000.000kHz VBW:3000.000kHz
 Project : FG 252201

Frequency (MHz)	ERP (dBm)	Limit (dBm)	Over Limit (dB)	SPA Reading (dBm)	S.G. Power (dBm)	TX Cable loss (dB)	TX Antenna Gain (dBi)	Polarization (H/V)	Result
1672	-46.01	-13	-33.01	-52.18	-47.2	2.15	5.49	V	Pass
2509	-41.01	-13	-28.01	-50.58	-42.9	2.38	6.41	V	Pass
5018	-43.26	-13	-30.26	-61.05	-48	3.62	10.51	V	Pass
5854	-44.23	-13	-31.23	-63.84	-49	3.95	10.87	V	Pass
6691	-43.78	-13	-30.78	-65.06	-48.6	4.36	11.33	V	Pass



Band :	GSM850	Temperature :	23~24°C
Test Mode :	EDGE 8 Link	Relative Humidity :	51~53%
Test Engineer :	David Yang	Polarization :	Horizontal
Remark :	Spurious emissions within 30-1000MHz were found more than 20dB below limit line.		

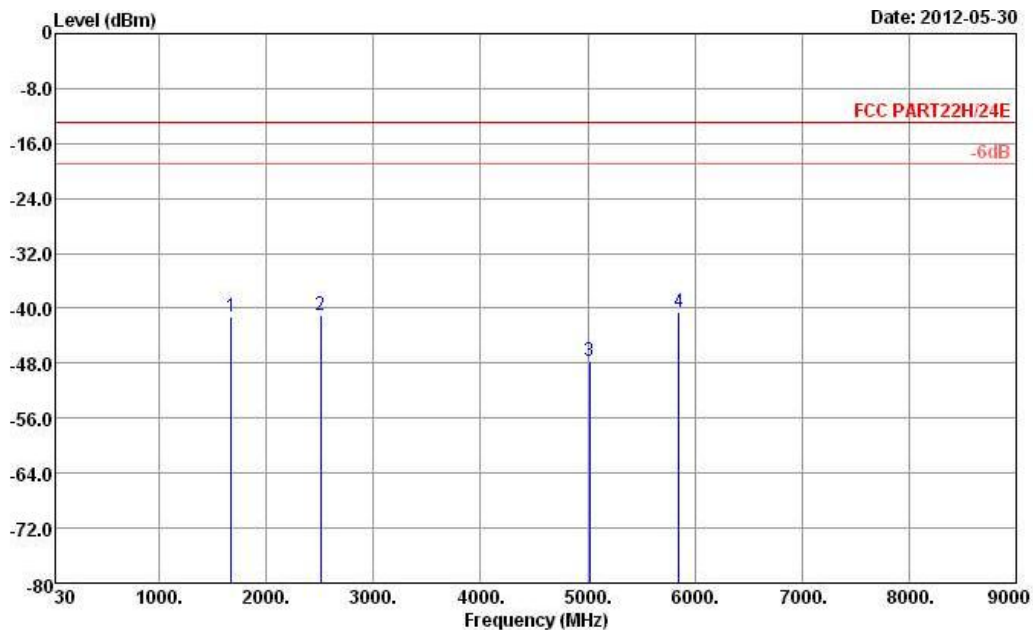

Site : 03CH05-HY
 Condition : FCC PART22H/24E HF_EIRP_101221 HORIZONTAL
 : RBW:1000.000KHz VBW:3000.000KHz
 Project : FG 252201

Frequency (MHz)	ERP (dBm)	Limit (dBm)	Over Limit (dB)	SPA Reading (dBm)	S.G. Power (dBm)	TX Cable loss (dB)	TX Antenna Gain (dBi)	Polarization (H/V)	Result
1672	-41.12	-13	-28.12	-47.45	-42.31	2.15	5.49	H	Pass
2509	-41.11	-13	-28.11	-50.36	-43	2.38	6.41	H	Pass
5018	-47.68	-13	-34.68	-64.82	-52.42	3.62	10.51	H	Pass
5854	-40.53	-13	-27.53	-59.77	-45.3	3.95	10.87	H	Pass



Band :	GSM850	Temperature :	23~24°C
Test Mode :	EDGE 8 Link	Relative Humidity :	51~53%
Test Engineer :	David Yang	Polarization :	Vertical
Remark :	Spurious emissions within 30-1000MHz were found more than 20dB below limit line.		

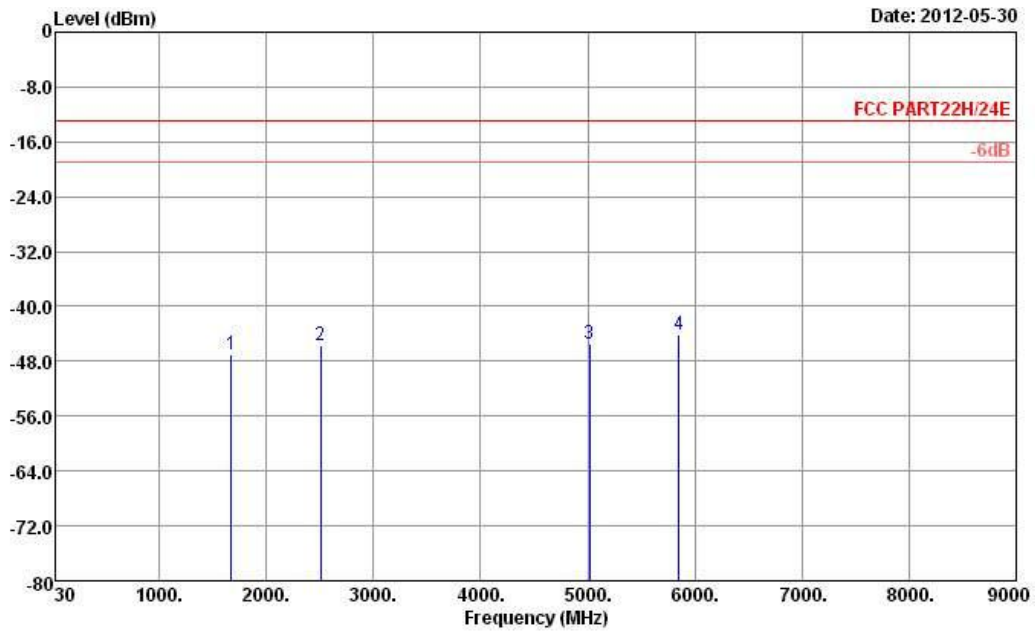

Site : 03CH05-HY
 Condition : FCC PART22H/24E HF_EIRP_101221 VERTICAL
 RBW:1000.000kHz VBW:3000.000kHz
 Project : FG 252201

Frequency (MHz)	ERP (dBm)	Limit (dBm)	Over Limit (dB)	SPA Reading (dBm)	S.G. Power (dBm)	TX Cable loss (dB)	TX Antenna Gain (dBi)	Polarization (H/V)	Result
1672	-47.12	-13	-34.12	-53.19	-48.31	2.15	5.49	V	Pass
2509	-45.63	-13	-32.63	-55.03	-47.52	2.38	6.41	V	Pass
5018	-45.57	-13	-32.57	-62.7	-50.31	3.62	10.51	V	Pass
5854	-44.04	-13	-31.04	-63.24	-48.81	3.95	10.87	V	Pass



Band :	GSM1900	Temperature :	23~24°C
Test Mode :	GSM Link	Relative Humidity :	51~53%
Test Engineer :	David Yang	Polarization :	Horizontal
Remark :	Spurious emissions within 30-1000MHz were found more than 20dB below limit line.		

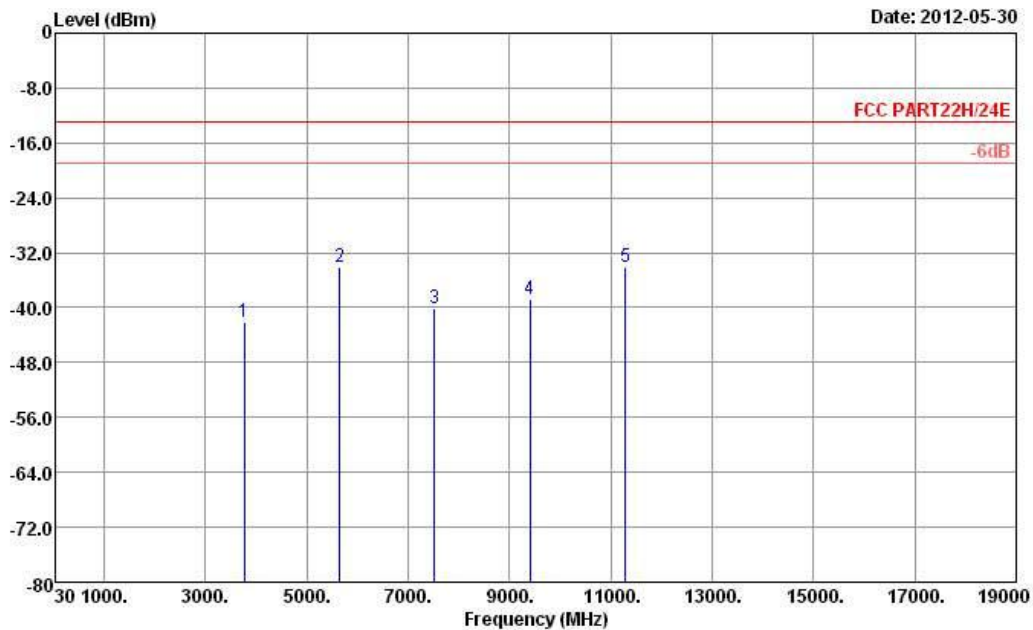

Site : 03CH05-HY
 Condition : FCC PART22H/24E HF_EIRP_101221 HORIZONTAL
 : RBW:1000.000kHz VBW:3000.000kHz
 Project : FG 252201

Frequency (MHz)	EIRP (dBm)	Limit (dBm)	Over Limit (dB)	SPA Reading (dBm)	S.G. Power (dBm)	TX Cable loss (dB)	TX Antenna Gain (dBi)	Polarization (H/V)	Result
3760	-42.09	-13	-29.09	-55.77	-48.22	2.9292	9.06	H	Pass
5640	-34.11	-13	-21.11	-53.32	-41.03	3.9072	10.83	H	Pass
7520	-40.07	-13	-27.07	-62.13	-48.09	4.5988	12.62	H	Pass
9400	-38.85	-13	-25.85	-62.83	-46.81	5.398	13.36	H	Pass
11280	-34.01	-13	-21.01	-61.19	-41.42	5.9324	13.34	H	Pass



Band :	GSM1900	Temperature :	23~24°C
Test Mode :	GSM Link	Relative Humidity :	51~53%
Test Engineer :	David Yang	Polarization :	Vertical
Remark :	Spurious emissions within 30-1000MHz were found more than 20dB below limit line.		

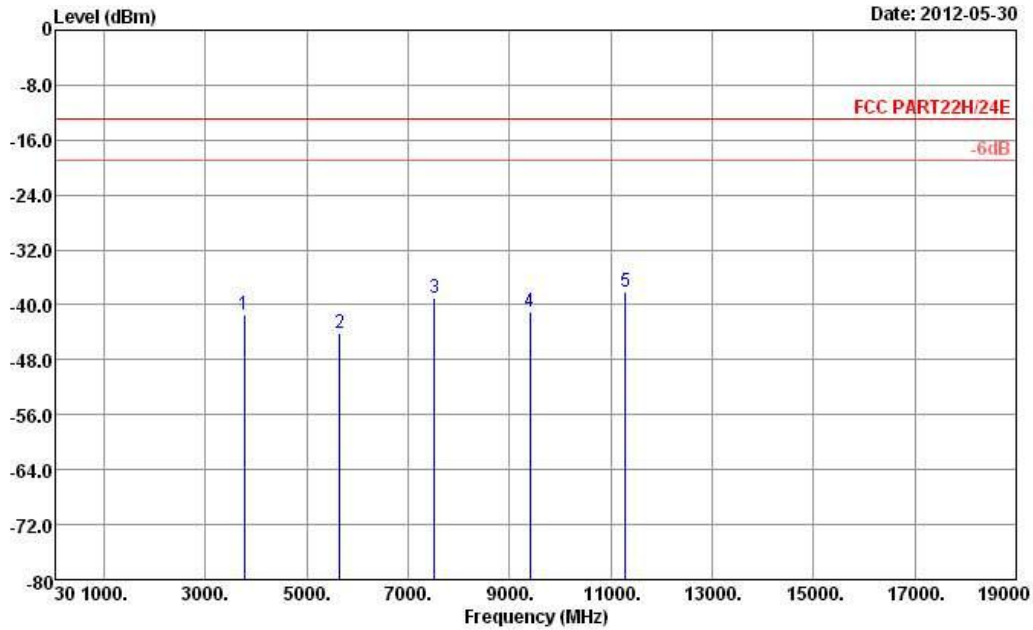

Site : 03CH05-HY
 Condition : FCC PART22H/24E HF_EIRP_101221 VERTICAL
 RBW:1000.000kHz VBW:3000.000kHz
 Project : FG 252201

Frequency (MHz)	EIRP (dBm)	Limit (dBm)	Over Limit (dB)	SPA Reading (dBm)	S.G. Power (dBm)	TX Cable loss (dB)	TX Antenna Gain (dBi)	Polarization (H/V)	Result
3760	-41.37	-13	-28.37	-54.99	-47.5	2.9292	9.06	V	Pass
5640	-44.08	-13	-31.08	-62.91	-51	3.9072	10.83	V	Pass
7520	-38.90	-13	-25.90	-60.8	-46.92	4.5988	12.62	V	Pass
9400	-41.04	-13	-28.04	-65.23	-49	5.398	13.36	V	Pass
11280	-38.10	-13	-25.10	-65.12	-45.51	5.9324	13.34	V	Pass



Band :	GSM1900	Temperature :	23~24°C
Test Mode :	EDGE 8 Link	Relative Humidity :	51~53%
Test Engineer :	David Yang	Polarization :	Horizontal
Remark :	Spurious emissions within 30-1000MHz were found more than 20dB below limit line.		

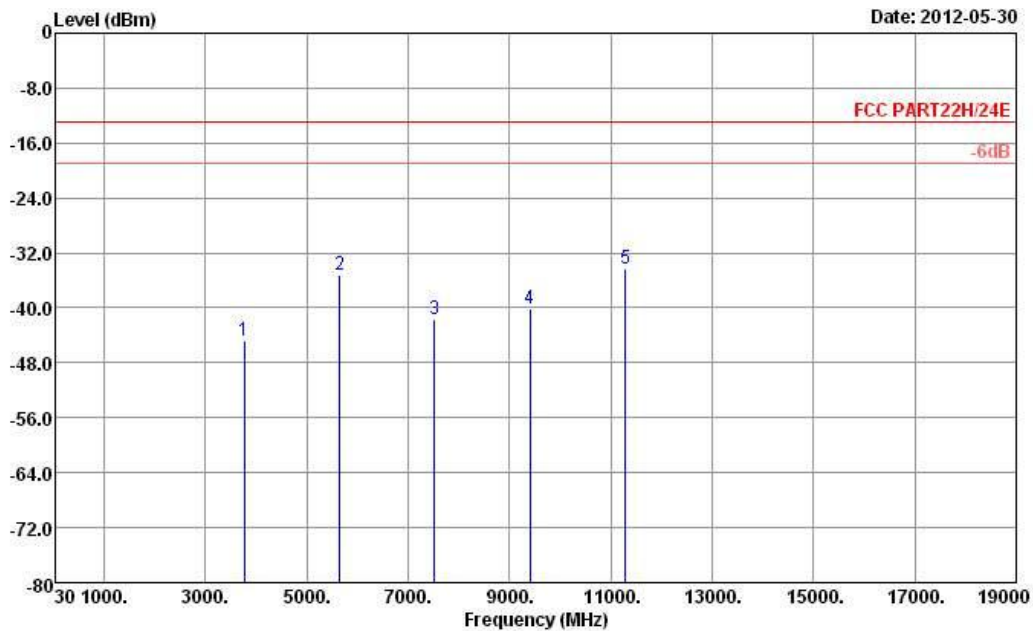

Site : 03CH05-HY
 Condition : FCC PART22H/24E HF_EIRP_101221 HORIZONTAL
 RBW:1000.000kHz VBW:3000.000kHz
 Project : FG 252201

Frequency (MHz)	EIRP (dBm)	Limit (dBm)	Over Limit (dB)	SPA Reading (dBm)	S.G. Power (dBm)	TX Cable loss (dB)	TX Antenna Gain (dBi)	Polarization (H/V)	Result
3760	-44.87	-13	-31.87	-58.33	-51	2.9292	9.06	H	Pass
5640	-35.24	-13	-22.24	-54.12	-42.16	3.9072	10.83	H	Pass
7520	-41.74	-13	-28.74	-63.65	-49.76	4.5988	12.62	H	Pass
9400	-40.04	-13	-27.04	-64.13	-48	5.398	13.36	H	Pass
11280	-34.35	-13	-21.35	-61.42	-41.76	5.9324	13.34	H	Pass



Band :	GSM1900	Temperature :	23~24°C
Test Mode :	EDGE 8 Link	Relative Humidity :	51~53%
Test Engineer :	David Yang	Polarization :	Vertical
Remark :	Spurious emissions within 30-1000MHz were found more than 20dB below limit line.		

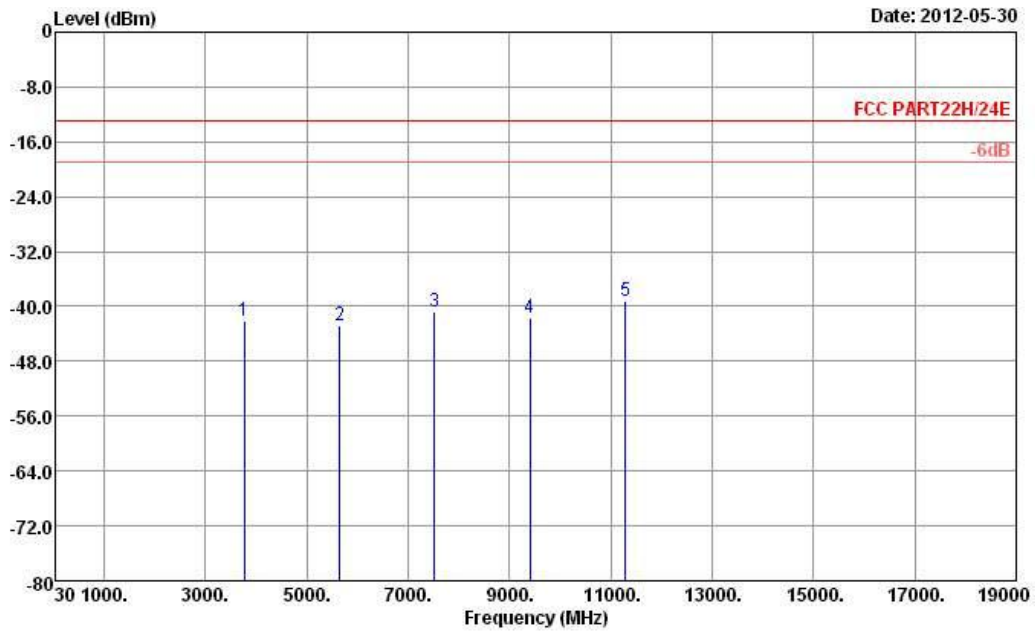

Site : 03CH05-HY
 Condition : FCC PART22H/24E HF_EIRP_101221 VERTICAL
 RBW:1000.000kHz VBW:3000.000kHz
 Project : FG 252201

Frequency (MHz)	EIRP (dBm)	Limit (dBm)	Over Limit (dB)	SPA Reading (dBm)	S.G. Power (dBm)	TX Cable loss (dB)	TX Antenna Gain (dBi)	Polarization (H/V)	Result
3760	-42.10	-13	-29.10	-55.87	-48.23	2.9292	9.06	V	Pass
5640	-42.76	-13	-29.76	-61.69	-49.68	3.9072	10.83	V	Pass
7520	-40.81	-13	-27.81	-62.79	-48.83	4.5988	12.62	V	Pass
9400	-41.65	-13	-28.65	-65.59	-49.61	5.398	13.36	V	Pass
11280	-39.22	-13	-26.22	-66.45	-46.63	5.9324	13.34	V	Pass



Band :	WCDMA Band V	Temperature :	23~24°C
Test Mode :	RMC 12.2Kbps Link	Relative Humidity :	51~53%
Test Engineer :	David Yang	Polarization :	Horizontal
Remark :	Spurious emissions within 30-1000MHz were found more than 20dB below limit line.		

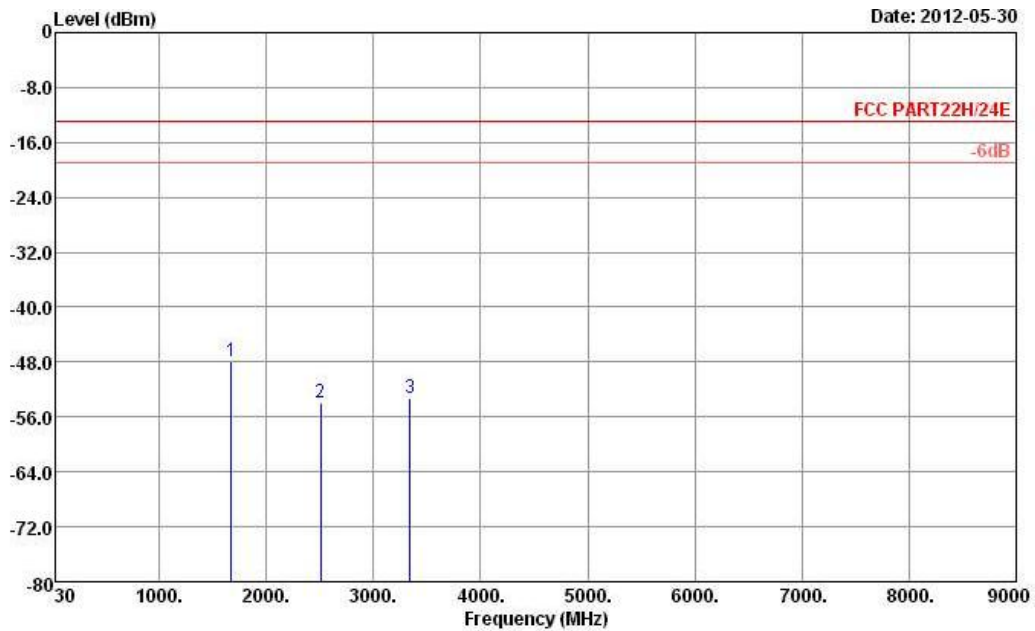

Site : 03CH05-HY
 Condition : FCC PART22H/24E HF_EIRP_101221 HORIZONTAL
 : RBW:1000.000KHz VBW:3000.000KHz
 Project : FG 252201

Frequency (MHz)	ERP (dBm)	Limit (dBm)	Over Limit (dB)	SPA Reading (dBm)	S.G. Power (dBm)	TX Cable loss (dB)	TX Antenna Gain (dBi)	Polarization (H/V)	Result
1672	-48.01	-13	-35.01	-53.98	-49.2	2.15	5.49	H	Pass
2509	-54.01	-13	-41.01	-63.31	-55.9	2.38	6.41	H	Pass
3345	-53.17	-13	-40.17	-64.83	-56.5	2.86	8.34	H	Pass



Band :	WCDMA Band V	Temperature :	23~24°C
Test Mode :	RMC 12.2Kbps Link	Relative Humidity :	51~53%
Test Engineer :	David Yang	Polarization :	Vertical
Remark :	Spurious emissions within 30-1000MHz were found more than 20dB below limit line.		

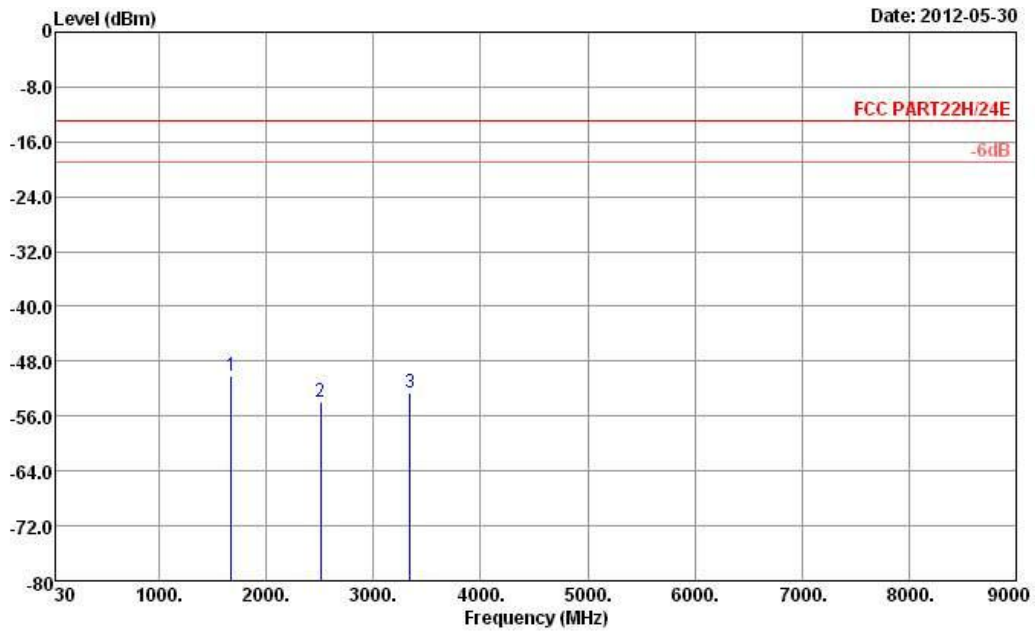

Site : 03CH05-HY
 Condition : FCC PART22H/24E HF_EIRP_101221 VERTICAL
 RBW:1000.000kHz VBW:3000.000kHz
 Project : FG 252201

Frequency (MHz)	ERP (dBm)	Limit (dBm)	Over Limit (dB)	SPA Reading (dBm)	S.G. Power (dBm)	TX Cable loss (dB)	TX Antenna Gain (dBi)	Polarization (H/V)	Result
1672	-50.11	-13	-37.11	-56.14	-51.3	2.15	5.49	V	Pass
2509	-54.02	-13	-41.02	-63.28	-55.91	2.38	6.41	V	Pass
3345	-52.67	-13	-39.67	-64.2	-56	2.86	8.34	V	Pass



Band :	WCDMA Band II	Temperature :	23~24°C
Test Mode :	RMC 12.2Kbps Link	Relative Humidity :	51~53%
Test Engineer :	David Yang	Polarization :	Horizontal
Remark :	Spurious emissions within 30-1000MHz were found more than 20dB below limit line.		

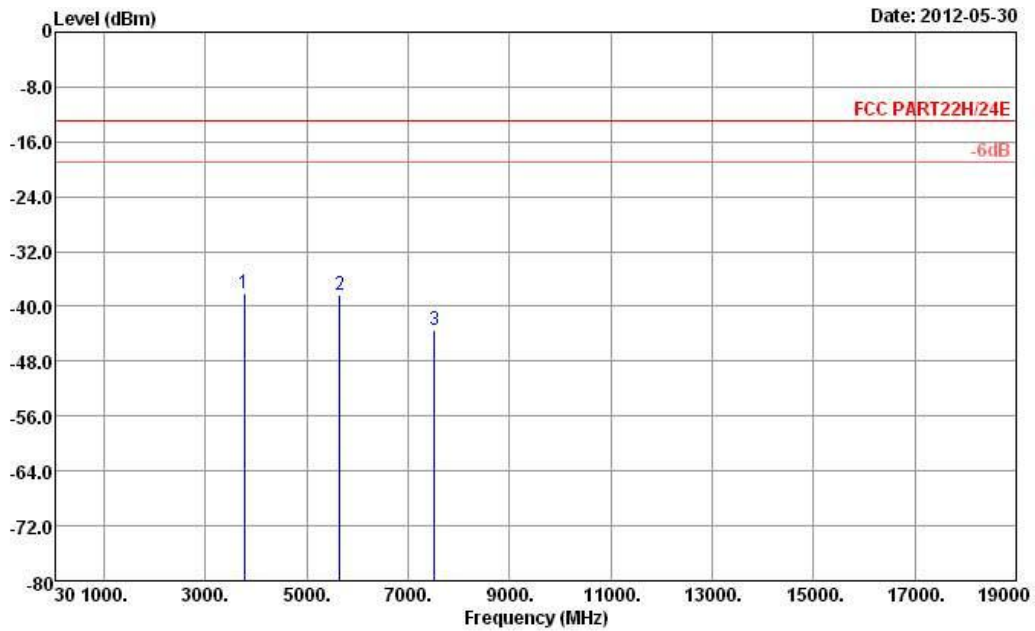

Site : 03CH05-HY
 Condition : FCC PART22H/24E HF_EIRP_101221 HORIZONTAL
 : RBW:1000.000kHz VBW:3000.000kHz
 Project : FG 252201

Frequency (MHz)	EIRP (dBm)	Limit (dBm)	Over Limit (dB)	SPA Reading (dBm)	S.G. Power (dBm)	TX Cable loss (dB)	TX Antenna Gain (dBi)	Polarization (H/V)	Result
3760	-38.01	-13	-25.01	-51.46	-44.14	2.9292	9.06	H	Pass
5640	-38.31	-13	-25.31	-57.31	-45.23	3.9072	10.83	H	Pass
7520	-43.44	-13	-30.44	-65.55	-51.46	4.5988	12.62	H	Pass



Band :	WCDMA Band II	Temperature :	23~24°C
Test Mode :	RMC 12.2Kbps Link	Relative Humidity :	51~53%
Test Engineer :	David Yang	Polarization :	Vertical
Remark :	Spurious emissions within 30-1000MHz were found more than 20dB below limit line.		

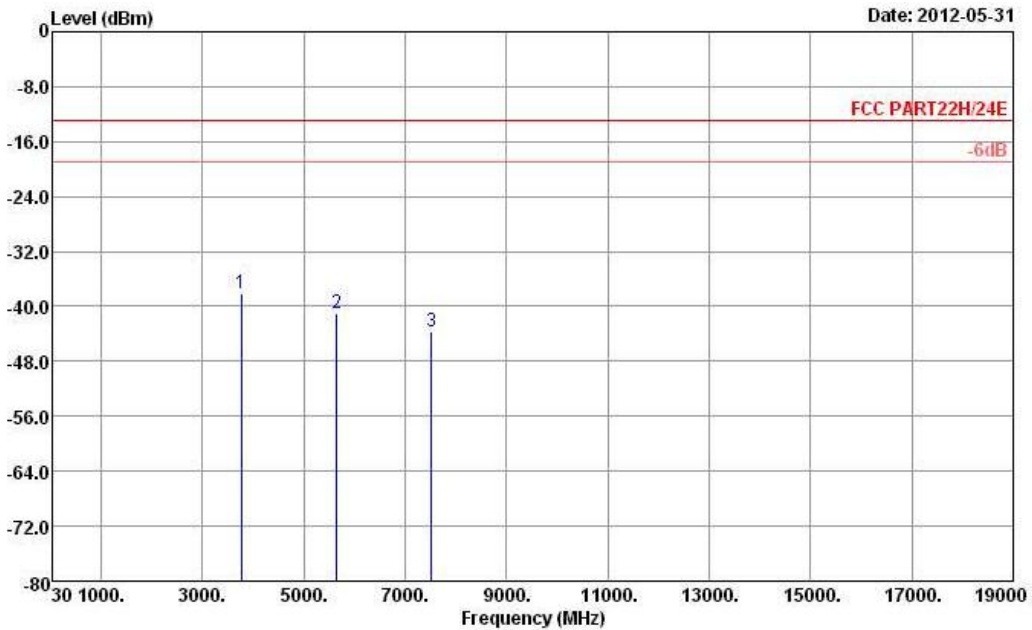

Site : 03CH05-HY
 Condition : FCC PART22H/24E HF_EIRP_101221 VERTICAL
 : RBW:1000.000KHz VBW:3000.000KHz
 Project : FG 252201

Frequency (MHz)	EIRP (dBm)	Limit (dBm)	Over Limit (dB)	SPA Reading (dBm)	S.G. Power (dBm)	TX Cable loss (dB)	TX Antenna Gain (dBi)	Polarization (H/V)	Result
3760	-38.14	-13	-25.14	-51.55	-44.27	2.9292	9.06	V	Pass
5640	-41.00	-13	-28.00	-59.82	-47.92	3.9072	10.83	V	Pass
7520	-43.62	-13	-30.62	-65.68	-51.64	4.5988	12.62	V	Pass

3.7 Frequency Stability Measurement

3.7.1 Description of Frequency Stability Measurement

The frequency stability shall be measured by variation of ambient temperature and variation of primary supply voltage to ensure that the fundamental emission stays within the authorized frequency block. The frequency stability of the transmitter shall be maintained within $\pm 0.00025\%$ ($\pm 2.5\text{ppm}$) of the center frequency.

3.7.2 Measuring Instruments

See list of measuring instruments of this test report.

3.7.3 Test Procedures for Temperature Variation

1. The EUT was set up in the thermal chamber and connected with the base station.
2. With power OFF, the temperature was decreased to -30°C and the EUT was stabilized before testing. Power was applied and the maximum change in frequency was recorded within one minute.
3. With power OFF, the temperature was raised in 10°C step up to 50°C . The EUT was stabilized at each step for at least half an hour. Power was applied and the maximum frequency change was recorded within one minute.
4. If the EUT cannot be turned on at -30°C , the testing lowest temperature will be raised in 10°C step until the EUT can be turned on.

3.7.4 Test Procedures for Voltage Variation

1. The EUT was placed in a temperature chamber at $25\pm 5^{\circ}\text{C}$ and connected with the base station.
2. The power supply voltage to the EUT was varied from BEP to 115% of the nominal value measured at the input to the EUT.
3. The variation in frequency was measured for the worst case.

3.7.5 Test Setup

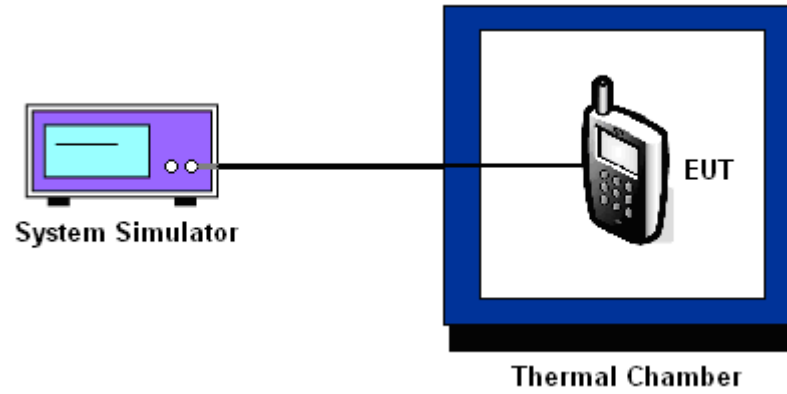



3.7.6 Test Result of Temperature Variation

Band :	GSM 850	Channel :	189
Limit (ppm) :	2.5		

Temperature (°C)	GSM		EDGE 8		Result
	Freq. Dev. (Hz)	Deviation (ppm)	Freq. Dev. (Hz)	Deviation (ppm)	
-30	-25	-0.03	24	0.03	PASS
-20	32	0.04	16	0.02	
-10	-33	-0.04	-32	-0.04	
0	-28	-0.03	-47	-0.06	
10	-20	-0.02	-22	-0.03	
20	31	0.04	-24	-0.03	
30	-24	-0.03	-38	-0.04	
40	-33	-0.04	-19	-0.02	
50	-30	-0.04	28	0.03	

Band :	GSM 1900	Channel :	661
Limit (ppm) :	2.5		

Temperature (°C)	GSM		EDGE 8		Result
	Freq. Dev. (Hz)	Deviation (ppm)	Freq. Dev. (Hz)	Deviation (ppm)	
-30	-34	-0.02	-52	-0.03	PASS
-20	-28	-0.01	-47	-0.02	
-10	-56	-0.03	-71	-0.04	
0	-55	-0.03	-78	-0.04	
10	-52	-0.03	-46	-0.02	
20	-43	-0.02	-52	-0.03	
30	-28	-0.01	-61	-0.03	
40	-43	-0.02	-39	-0.02	
50	-60	-0.03	-89	-0.05	



Band :	WCDMA Band V	Channel :	4182
Limit (ppm) :	2.5		

Temperature (°C)	RMC 12.2Kbps		Result
	Freq. Dev. (Hz)	Deviation (ppm)	
-30	-16	-0.02	PASS
-20	-18	-0.02	
-10	14	0.02	
0	19	0.02	
10	-19	-0.02	
20	20	0.02	
30	-15	-0.02	
40	-17	-0.02	
50	19	0.02	

Band :	WCDMA Band II	Channel :	9400
Limit (ppm) :	2.5		

Temperature (°C)	RMC 12.2Kbps		Result
	Freq. Dev. (Hz)	Deviation (ppm)	
-30	-57	-0.03	PASS
-20	-41	-0.02	
-10	-33	-0.02	
0	36	0.02	
10	34	0.02	
20	30	0.02	
30	-31	-0.02	
40	-29	-0.02	
50	-35	-0.02	



3.7.7 Test Result of Voltage Variation

Band & Channel	Mode	Voltage (Volt)	Freq. Dev. (Hz)	Deviation (ppm)	Limit (ppm)	Result
GSM 850 CH189	GSM	3.7	-30	-0.04	2.5	PASS
		BEP	-26	-0.03		
		4.1	-28	-0.03		
	EDGE 8	3.7	-26	-0.03		
		BEP	-28	-0.03		
		4.1	-23	-0.03		
GSM 1900 CH661	GSM	3.7	-48	-0.03		
		BEP	-45	-0.02		
		4.1	-43	-0.02		
	EDGE 8	3.7	-49	-0.03		
		BEP	-40	-0.02		
		4.1	-58	-0.03		
WCDMA Band V CH4182	RMC 12.2Kbps	3.7	-21	-0.02		
		BEP	-27	-0.03		
		4.1	-23	-0.03		
WCDMA Band II CH9400	RMC 12.2Kbps	3.7	-38	-0.02		
		BEP	32	0.02		
		4.1	-41	-0.02		

Note:

1. Normal Voltage = 3.7V.
2. Battery End Point (BEP) = 3.5 V.



4 List of Measuring Equipment

Instrument	Manufacturer	Model No.	Serial No.	Characteristics	Calibration Date	Test Date	Due Date	Remark
System Simulator	R&S	CMU200	117995	N/A	Jul. 28, 2011	May 29, 2012 ~ Jun. 09, 2012	Jul. 27, 2012	Conducted (TH02-HY)
Spectrum Analyzer	R&S	FSP40	100055	9kHz~40GHz	Jun. 13, 2011	May 29, 2012 ~ Jun. 09, 2012	Jun. 12, 2012	Conducted (TH02-HY)
Thermal Chamber	Ten Billion	TTH-D35P	TBN-930701	N/A	Jul. 27, 2011	May 29, 2012 ~ Jun. 09, 2012	Jul. 26, 2012	Conducted (TH02-HY)
Spectrum Analyzer	R&S	ESU26	100390	20Hz ~ 26.5GHz	Dec. 22, 2011	May 30, 2012 ~ May 31, 2012	Dec. 21, 2012	Radiation (03CH05-HY)
Bilog Antenna	SCHAFFNER	CBL6111C	2725	30MHz ~ 2GHz	Oct. 22, 2011	May 30, 2012 ~ May 31, 2012	Oct. 21, 2012	Radiation (03CH05-HY)
Turn Table	HD	Deis HD 2000	420/611	0 ~ 360 degree	N/A	May 30, 2012 ~ May 31, 2012	N/A	Radiation (03CH05-HY)
Antenna Mast	HD	MA 240	240/666	1 m ~ 4 m	N/A	May 30, 2012 ~ May 31, 2012	N/A	Radiation (03CH05-HY)
Horn Antenna	ESCO	3117	66584	1GHz ~ 18GHz	Aug. 04, 2011	May 30, 2012 ~ May 31, 2012	Aug. 03, 2012	Radiation (03CH05-HY)
SHF-EHF Horn Antenna	SCHWARZBECK	BBHA 9170	BBHA917025 1	15GHz ~ 40GHz	Oct. 21, 2011	May 30, 2012 ~ May 31, 2012	Oct. 20, 2012	Radiation (03CH05-HY)
Pre Amplifier	COM-POWER	PA-103A	161075	10Hz ~ 1000MHz Gain:32dB	Feb. 27, 2012	May 30, 2012 ~ May 31, 2012	Feb. 26, 2013	Radiation (03CH05-HY)
Pre Amplifier	MITEQ	AMF-7D-00 101800-30-1	159087	1GHz~18GHz	Feb. 27, 2012	May 30, 2012 ~ May 31, 2012	Feb. 26, 2013	Radiation (03CH05-HY)
Pre Amplifier	Agilent	8449B	3008A01917	1GHz~26.5GHz	Aug. 30, 2011	May 30, 2012 ~ May 31, 2012	Aug. 29, 2012	Radiation (03CH05-HY)
Loop Antenna	R&S	HFH2-Z2	860004/001	9 kHz~30 MHz	Jul. 29, 2010	May 30, 2012 ~ May 31, 2012	Jul. 28, 2012	Radiation (03CH05-HY)
System Simulator	R&S	CMU200	117591	N/A	Oct. 21, 2011	May 30, 2012 ~ May 31, 2012	Oct. 20, 2013	Radiation (03CH06-HY)

5 Uncertainty of Evaluation

Uncertainty of Radiated Emission Measurement (30 MHz ~ 1000 MHz)

Contribution	Uncertainty of X_i		$u(X_i)$
	dB	Probability Distribution	
Receiver Reading	0.41	Normal (k=2)	0.21
Antenna Factor Calibration	0.83	Normal (k=2)	0.42
Cable Loss Calibration	0.25	Normal (k=2)	0.13
Pre-Amplifier Gain Calibration	0.27	Normal (k=2)	0.14
RCV/SPA Specification	2.50	Rectangular	0.72
Antenna Factor Interpolation for Frequency	1.00	Rectangular	0.29
Site Imperfection	1.43	Rectangular	0.83
Mismatch	+0.39 / -0.41	U-Shape	0.28
Combined Standard Uncertainty $U_c(y)$	1.27		
Measuring Uncertainty for a Level of Confidence of 95% ($U = 2U_c(y)$)	2.54		

Uncertainty of Radiated Emission Measurement (1 GHz ~ 40 GHz)

Contribution	Uncertainty of X_i		$u(X_i)$	C_i	$C_i * u(X_i)$
	dB	Probability Distribution			
Receiver Reading	± 0.10	Normal (k=2)	0.10	1	0.10
Antenna Factor Calibration	± 1.70	Normal (k=2)	0.85	1	0.85
Cable Loss Calibration	± 0.50	Normal (k=2)	0.25	1	0.25
Receiver Correction	± 2.00	Rectangular	1.15	1	1.15
Antenna Factor Directional	± 1.50	Rectangular	0.87	1	0.87
Site Imperfection	± 2.80	Triangular	1.14	1	1.14
Mismatch Receiver VSWR $\Gamma_1 = 0.197$ Antenna VSWR $\Gamma_2 = 0.194$ Uncertainty = $20\text{Log}(1-\Gamma_1*\Gamma_2)$	+0.34 / -0.35	U-Shape	0.244	1	0.244
Combined Standard Uncertainty $U_c(y)$	2.36				
Measuring Uncertainty for a Level of Confidence of 95% ($U = 2U_c(y)$)	4.72				



Appendix A. Photographs of EUT

Please refer to Sporton report number EP252201 as below.