

Test Report

Product: Wireless carplay adapter

Trade Mark: N/A

Model Number: KY-4165

FCC ID: 2BPTS-KY-4165

Prepared for

Dongguan Kinspeed Technology co., Ltd.
Room 608, Building 5, No. 9 Yuhu Road, Fenggang Town, Dongguan City,
Guangdong Province

Prepared by

Shenzhen HongBiao Certification& Testing Co., Ltd
Room 102, 201, Building 2, Yuanwanggu RFID Industrial Park, Tongguan
Road, Tianliao Community, Yutang Street, Guangming District, Shenzhen,
China

Tel.: +86-755-2998 9321 Fax.: +86-755-2998 5110

Website: <http://www.sz-hongbiao.com>

Table of Contents

1	GENERAL DESCRIPTION	6
1.1	DESCRIPTION OF EUT	6
1.2	TEST MODE.....	6
1.3	OPERATION CHANNEL LIST	6
1.4	TEST SETUP	7
1.5	POWER SETTING CONFIGURATION PARAMETERS	7
1.6	ANCILLARY EQUIPMENT	8
2	SUMMARY OF TEST RESULT	9
3	TEST FACILITIES AND ACCREDITATIONS	10
3.1	TEST LABORATORY	10
3.2	ENVIRONMENTAL CONDITIONS	10
3.3	MEASUREMENT UNCERTAINTY	10
3.4	TEST SOFTWARE.....	11
4	LIST OF TEST EQUIPMENT	12
5	TEST ITEM AND RESULTS.....	14
5.1	ANTENNA REQUIREMENT	14
5.1.1	<i>Standard Requirement</i>	14
5.1.2	<i>Test Result</i>	14
5.2	CONDUCTED EMISSION.....	15
5.2.1	<i>Limits</i>	15
5.2.2	<i>Test Procedures</i>	15
5.2.3	<i>Test Setup</i>	16
5.2.4	<i>Test Result</i>	16
5.3	RADIATED EMISSION	19
5.3.1	<i>Limits</i>	19
5.3.2	<i>Test Procedures</i>	19
5.3.3	<i>Test Setup</i>	19
5.3.4	<i>Test Result</i>	20
5.3.5	<i>Radiated Band Edge</i>	25
5.4	PEAK OUTPUT POWER	26
5.4.1	<i>Limit</i>	26
5.4.2	<i>Test Procedure</i>	26
5.4.3	<i>Test Setup</i>	26
5.4.4	<i>Test Results</i>	26
5.5	20DB OCCUPIED CHANNEL BANDWIDTH.....	30
5.5.1	<i>Limit</i>	30
5.5.2	<i>Test Procedure</i>	30
5.5.3	<i>Test Setup</i>	30
5.5.4	<i>Test results</i>	30
5.6	CARRIER FREQUENCY SEPARATION	36
5.6.1	<i>Limit</i>	36
5.6.2	<i>Test Procedure</i>	36
5.6.3	<i>Test Setup</i>	36
5.6.4	<i>Test Results</i>	36
5.7	HOPPING CHANNEL NUMBER	39
5.7.1	<i>Limit</i>	39
5.7.2	<i>Test Procedure</i>	39
5.7.3	<i>Test Setup</i>	39
5.7.4	<i>Test Results</i>	39
5.8	DWELL TIME.....	42
5.8.1	<i>Limit</i>	42

5.8.2	Test Procedure	42
5.8.3	Test Setup	42
5.8.4	Test Results	42
5.9	CONDUCTED BAND EDGE	47
5.9.1	Limit	47
5.9.2	Test Procedure	47
5.9.3	Test Setup	47
5.9.4	Test Results	47
5.10	SPURIOUS RF CONDUCTED EMISSIONS.....	54
5.10.1	Limit	54
5.10.2	Test Procedure	54
5.10.3	Test Setup	54
5.10.4	Test Results	54
6	PHOTOGRAPHS OF THE TEST SETUP	58
7	PHOTOGRAPHS OF THE EUT	60

TEST RESULT CERTIFICATION

Applicant's Name..... : Dongguan Kinspeed Technology co., Ltd.
Address : Room 608, Building 5, No. 9 Yuhu Road, Fenggang Town,
Dongguan City, Guangdong Province

Manufacturer's Name : Dongguan Kinspeed Technology co., Ltd.
Address : Room 608, Building 5, No. 9 Yuhu Road, Fenggang Town,
Dongguan City, Guangdong Province

Product description

Product name : Wireless carplay adapter
Model Number : KY-4165
Standards : FCC Part 15.247
Test procedure..... : IEEE/ANSI C63.10-2020
KDB558074 D01 15.247 Meas Guidance v05r02

This device described above has been tested by Shenzhen HongBiao Certification& Testing Co., Ltd and the test results show that the equipment under test (EUT) is in compliance with the EMC requirements. And it is applicable only to the tested sample identified in the report.

Date of Test

Date (s) of performance of tests..... : May 27, 2025~ June 11, 2025
Test Result..... : **Pass**

Testing Engineer : Zoe su
(Z o e S u)

Technical Manager : Ming Liu
(Ming Liu)

Authorized Signatory : Leo Su
(L e o S u)

1 General Description

1.1 Description of EUT

Product name:	Wireless carplay adapter
Model name:	KY-4165
Series Model:	KY-4167, KY-4169, KY-4171, KY-4173, KY-4175, KY-4176, KY-4177, KY-4178, KY-4179, KY-4180, KY-4181, KY-4182, KY-4183, KY-4184, KY-4186, KY-4187, KY-4188, KY-4189, KY-4190, KY-4191
Different of series model:	Except for the model, appearance color, appearance shape, appearance materials, electronic accessories, all models have the same circuits and modules.
Operation frequency:	2402-2480MHz
Modulation type:	GFSK, $\pi/4$ -DQPSK, 8DPSK
Bit Rate of transmitter:	1Mbps, 2Mbps, 3Mbps
Antenna type:	PCB Antenna
Antenna gain:	4.29dBi
Max. output power:	1.95dBm
Hardware version:	V0.3
Software version:	202407041001C
Battery:	N/A
Power supply:	Input: DC 5V/1A
Adapter information:	N/A

Note: The circuit and electronic structure of all models listed in the report have not changed, and differences between all models have been tested. The final report only reflects the test data of the KY-4165 main model in the worst-case scenario.

1.2 Test Mode

Test Mode	Channel	Frequency (MHz)
1	00	2402
2	39	2441
3	78	2480

1.3 Operation Channel List

Channel	Frequency (MHz)	Channel	Frequency (MHz)	Channel	Frequency (MHz)

00	2402	27	2429	54	2456
01	2403	28	2430	55	2457
02	2404	29	2431	56	2458
03	2405	30	2432	57	2459
04	2406	31	2433	58	2460
05	2407	32	2434	59	2461
06	2408	33	2435	60	2462
07	2409	34	2436	61	2463
08	2410	35	2437	62	2464
09	2411	36	2438	63	2465
10	2412	37	2439	64	2466
11	2413	38	2440	65	2467
12	2414	39	2441	66	2468
13	2415	40	2442	67	2469
14	2416	41	2443	68	2470
15	2417	42	2444	69	2471
16	2418	43	2445	70	2472
17	2419	44	2446	71	2473
18	2420	45	2447	72	2474
19	2421	46	2448	73	2475
20	2422	47	2449	74	2476
21	2423	48	2450	75	2477
22	2424	49	2451	76	2478
23	2425	50	2452	77	2479
24	2426	51	2453	78	2480
25	2427	52	2454	--	--
26	2428	53	2455	--	--

1.4 Test Setup

See photographs of the test setup in the report for the actual setup and connections between EUT and support equipment.

1.5 Power setting configuration parameters

During testing, Channel and Power Controlling Software provided by the customer was used to control the operating channel as well as the output power level. The RF output power selection is for the setting of RF output power expected by the customer and is going to be fixed on the firmware of the final end product. Transmitting duty cycle is no less 98%.

The software is PUSH and CMD tool Use together.

Test software Version		SecureCRT	
Frequency	2402 MHz	2441 MHz	2480 MHz
Parameters	Default	Default	Default
RF cable			

Description	Connector	Length	Supplied by
Antenna Cable	SMA	10cm	Applicant

Note: Disclaimer: the loss of RF cable is too small and can be ignored.

1.6 Ancillary Equipment

Equipment	Model	S/N	Manufacturer
Adapter	CD289	35810	Ugreen Group Limited
Laptop	BDR-WDH	A3RQPM242 0004454	HONR

Note: The laptop is used to assist the RF test. In order to prevent the laptop from causing unnecessary impact on the test, the laptop will be removed from the test environment after the EUT successfully transmits at a fixed frequency using the laptop.

2 Summary of Test Result

No.	Standard Section	Test Item	Result	Remark
1	15.203	Antenna Requirement	Pass	
2	15.247	Conducted emission	Pass	
3	15.247(d)	Band edge	Pass	
4	15.205/15.209	Spurious emission	Pass	
5	15.247(b)(1)	Peak output power	Pass	
6	15.247(a)(1)	20dB occupied bandwidth	Pass	
7	15.247(a)(1)	Carrier Frequencies Separation	Pass	
8	15.247(a)(1)	Hopping channel number	Pass	
9	15.247(a)(1)	Dwell time	Pass	
10	15.247(d)	Spurious RF Conducted Emissions	Pass	

3 Test Facilities and Accreditations

3.1 Test Laboratory

Test Site	Shenzhen HongBiao Certification& Testing Co., Ltd
Test Site Location	Room 102, 201, Building 2, Yuanwanggu RFID Industrial Park, Tongguan Road, Tianliao Community, Yutang Street, Guangming District, Shenzhen, China
Telephone:	(86-755) 2998 9321
Fax:	(86-755) 2998 5110
FCC Registration No.:	CN1341
A2LA Certificate No.:	6765.01

3.2 Environmental Conditions

During the measurement the environmental conditions were within the listed ranges:

Temperature:	15°C~35°C
Relative Humidity:	20%~75%
Air Pressure:	98kPa~101kPa

3.3 Measurement Uncertainty

The reported uncertainty of measurement $y \pm U$, where expanded uncertainty U is based on a standard uncertainty multiplied by a coverage factor of $k=2$, providing a level of confidence of approximately 95 %.

The data and results quoted in this document are true and accurate values, and uncertainties are not involved in the calculations.

In addition, components and mass production processes that are similar to testing equipment may introduce additional deviations, and the manufacturer is solely responsible for the continued compliance of the equipment.

Measurement Frequency Range	U, (dB)	Note
RF frequency	2×10^{-5}	
RF power, conducted	± 0.57 dB	
Conducted emission(150kHz~30MHz)	± 2.5 dB	
Radiated emission(9kHz-30MHz)	± 2.5 dB	
Radiated emission(30MHz~1GHz)	± 4.2 dB	
Radiated emission (above 1GHz)	± 4.7 dB	
Occupied Bandwidth	$\pm 3\%$	
Temperature	± 1 degree	
Humidity	$\pm 5 \%$	

3.4 Test Software

Software name	Manufacturer	Model	Version
Conducted Emission test Software	Farad	EZ-EMC	EMC-CON 3A1.1+
Radiated Emission test Software	Farad	EZ-EMC	FA-03A2
RF Test System	MWRF	MTS 8310	2.0.0.0

4 List of Test Equipment

Radiation emission							
Item	Equipment No.	Equipment name	Manufacturer	Model	Serial No.	Calibration date	Due date
1	HB-E001	Horn Antenna	Schwarzbeck	BBHA 9120D	02592	2024-05-18	2026-05-17
2	HB-E002	Biconical log-periodic composite antenna	Schwarzbeck	VULB 9168	01340	2024-05-18	2026-05-17
3	HB-E003	SHF-EHF Horn	Schwarzbeck	BBHA 91270	01193	2024-05-18	2026-05-17
4	HB-E005	Preamplifier	Noyetec	LAN-0118	NYCM1420102	2025-05-07	2026-05-06
5	HB-E006	Preamplifier	Noyetec	LAN-1840	NYCM1420103	2025-05-07	2026-05-06
6	HB-E007	EMI TEST RECEIVER	R&S	ESR7	102520	2025-05-07	2026-05-06
7	HB-E009	POSITINAL COTROLLE R	Noyetec	N/A	N/A	/	/
8	HB-E013	RF switch	Noyetec	NY-RF4	NY0CM1420204	/	/
9	HB-E066	Illuminance Tester	TASI	TA8121	N/A	2025-05-13	2026-05-12
10	HB-E075	Active loop antenna	Schwarzbeck	FMZB 1519B	1519B-245	2024-05-18	2026-05-17
11	HB-E076	Preamplifier	Hewlett Packard	8447D	1937A02278	2025-05-07	2026-05-06
Conduction emission							
Item	Equipment No.	Equipment name	Manufacturer	Model	Serial No.	Calibration date	Due date
1	HB-E014	4 Path V-LISN	Schwarzbeck	NNLK 8121	00770	2025-05-07	2026-05-06
2	HB-E015	Pulse Limiter	Schwarzbeck	VTSD 9561-F	00949	2025-05-07	2026-05-06
3	HB-E016	ZN23201	Noyetec	ZN23201	N/A	2025-05-10	2026-05-09
4	HB-E059	Attenuator	Xianghua	TS2-6-1	220215166	2025-05-10	2026-05-09
5	HB-E069	EMI TEST RECEIVER	R&S	ESCI	N/A	2025-05-07	2026-05-06
RF							
Item	Equipment No.	Equipment name	Manufacturer	Model	Serial No.	Calibration date	Due date
1	HB-E041	MXG AnaioG Signal Generator	Agilent	N5181A	MY47070421	2025-05-07	2026-05-06
2	HB-E042	WIDEBAND RADIO COMMUNICA	R&S	CMW500	132108	2025-05-08	2026-05-07

		TION TESTER					
3	HB-E043	MXG Anaioog Signal Generator	Agilent	N5182A	US46240335	2025-05-08	2026-05-07
4	HB-E044	Signal& spectrum Analyzer	R&S	FSV3044	101264	2025-05-07	2026-05-06
5	HB-E045	RF Control Box	Noyetec	NY100-R FCB	N/A	2025-05-08	2026-05-07
6	HB-E058	Thermometer Clock Humidity Monitor	N/A	HTC-1S	N/A	2025-05-09	2026-05-08

Note:

1. Note: the calibration interval of the above test instruments is 12&24 months and the calibrations are traceable to international system unit (SI).
2. The instrument RF Control Box, numbered HB-E045, contains power meter.

5 Test Item And Results

5.1 Antenna Requirement

5.1.1 Standard Requirement

15.203 requirement: For intentional device, according to 15.203: an intentional radiator shall be designed to ensure that no antenna other than that furnished by the responsible party shall be used with the device

5.1.2 Test Result

The EUT antenna is PCB Antenna. It comply with the standard requirement. In case of replacement of broken antenna the same antenna type must be used.

5.2 Conducted Emission

5.2.1 Limits

Limits – Class B		
Frequency (MHz)	Limit (dB μ V)	
	Quasi-Peak	Average
0.15 to 0.5	66 to 56*	56 to 46*
0.5 to 5	56	46
5 to 30	60	50

Note:

- the tighter limit applies at the band edges.
- the limit of " * " marked band means the limitation decreases linearly with the logarithm of the frequency in the range.

5.2.2 Test Procedures

a) EUT Operating Conditions

The EUT was configured for testing in a typical fashion (as a customer would normally use it). The EUT has been programmed to continuously transmit during test. This operating condition was tested and used to collect the included data.

b) The following table is the setting of the receiver

Receiver Parameters	Setting
Attenuation	10 dB
Start Frequency	0.15 MHz
Stop Frequency	30 MHz
IF Bandwidth	9 kHz

- The EUT was placed 0.8 meters from the horizontal ground plane with EUT being connected to the power mains through a line impedance stabilization network (LISN). All other support equipment powered from additional LISN(s). The LISN provide 50 Ohm/ 50uH of coupling impedance for the measuring instrument.
- Interconnecting cables that hang closer than 40 cm to the ground plane shall be folded back and forth in the center forming a bundle 30 to 40 cm long.
- I/O cables that are not connected to a peripheral shall be bundled in the center. The end of the cable may be terminated, if required, using the correct terminating impedance. The overall length shall not exceed 1 m.
- LISN is at least 80 cm from nearest part of EUT chassis.
- For the actual test configuration, please refer to the related Item – photographs of the test setup.

5.2.3 Test Setup

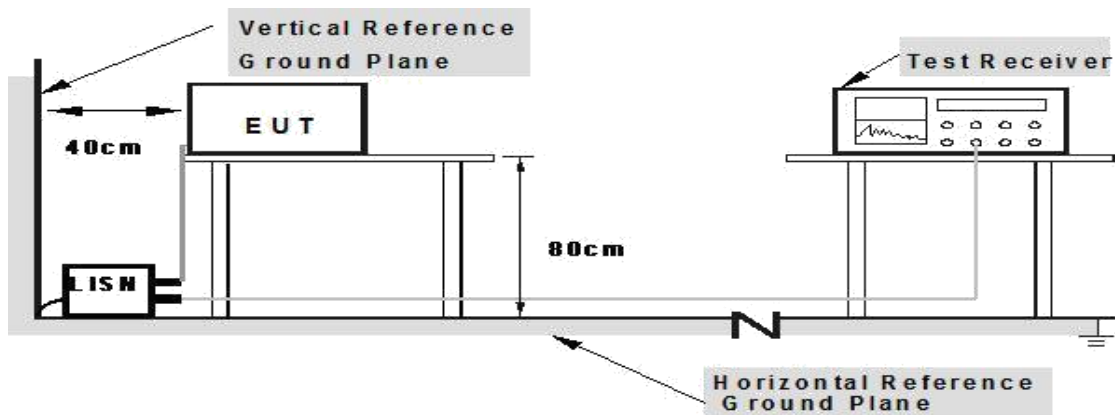

5.2.4 Test Result

EUT:	Wireless carplay adapter	Model Name:	KY-4165
Test Mode:	TX	Phase:	L
Test Voltage:	DC 5V from adapter AC 120V/60Hz		

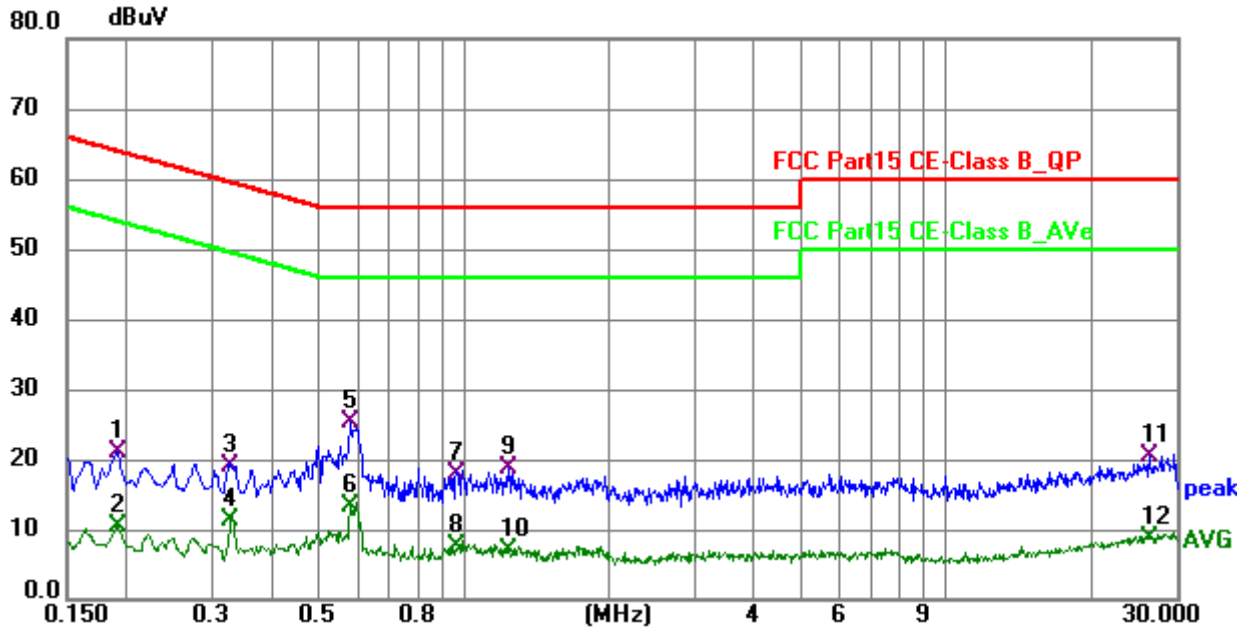

No.	Frequency (MHz)	Reading (dBuV)	Factor (dB)	Level (dBuV)	Limit (dBuV)	Margin (dB)	Detector
1	0.191	10.45	10.47	20.92	63.99	-43.07	QP
2	0.191	-0.09	10.47	10.38	53.99	-43.61	AVG
3	0.326	8.49	10.48	18.97	59.55	-40.58	QP
4	0.326	0.82	10.48	11.30	49.55	-38.25	AVG
5 *	0.582	14.89	10.50	25.39	56.00	-30.61	QP
6	0.582	2.85	10.50	13.35	46.00	-32.65	AVG
7	0.965	7.49	10.42	17.91	56.00	-38.09	QP
8	0.965	-2.87	10.42	7.55	46.00	-38.45	AVG
9	1.239	8.30	10.43	18.73	56.00	-37.27	QP
10	1.239	-3.56	10.43	6.87	46.00	-39.13	AVG
11	26.367	7.42	13.00	20.42	60.00	-39.58	QP
12	26.367	-4.29	13.00	8.71	50.00	-41.29	AVG

EUT:	Wireless carplay adapter	Model Name:	KY-4165
Test Mode:	TX	Phase:	N
Test Voltage:	DC 5V from adapter AC 120V/60Hz		

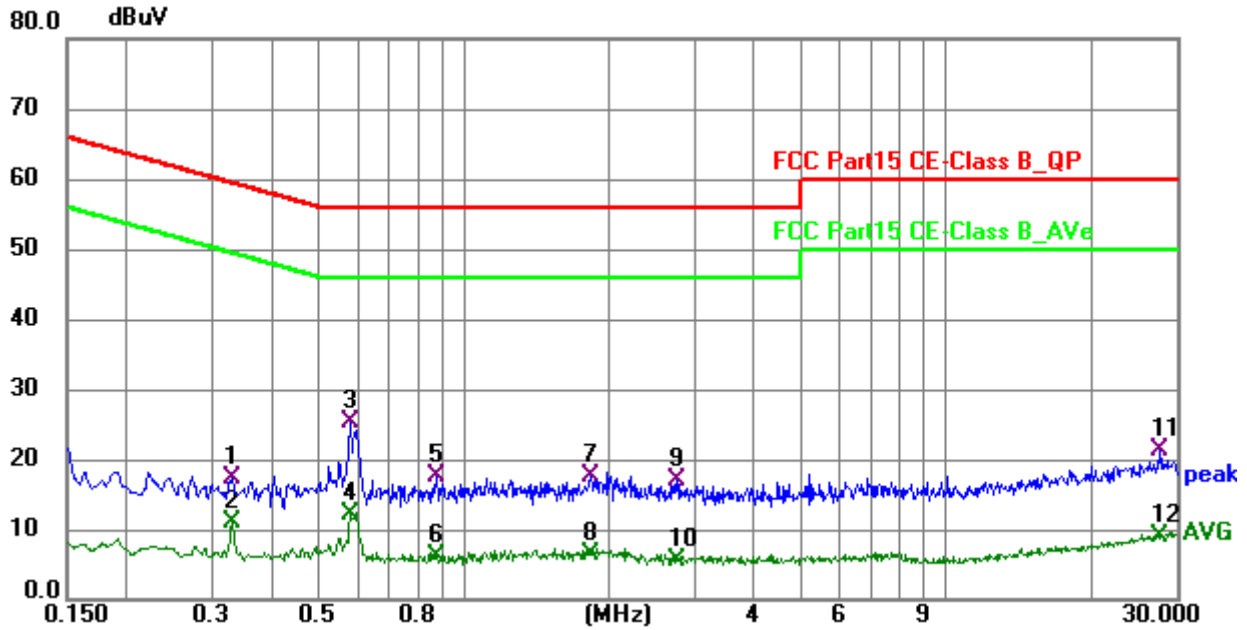

No.	Frequency (MHz)	Reading (dBuV)	Factor (dB)	Level (dBuV)	Limit (dBuV)	Margin (dB)	Detector
1	0.330	6.78	10.47	17.25	59.45	-42.20	QP
2	0.330	0.47	10.47	10.94	49.45	-38.51	AVG
3 *	0.582	14.86	10.39	25.25	56.00	-30.75	QP
4	0.582	1.65	10.39	12.04	46.00	-33.96	AVG
5	0.879	7.22	10.36	17.58	56.00	-38.42	QP
6	0.879	-4.10	10.36	6.26	46.00	-39.74	AVG
7	1.837	7.10	10.35	17.45	56.00	-38.55	QP
8	1.837	-3.80	10.35	6.55	46.00	-39.45	AVG
9	2.778	6.65	10.43	17.08	56.00	-38.92	QP
10	2.778	-5.00	10.43	5.43	46.00	-40.57	AVG
11	27.627	8.35	13.00	21.35	60.00	-38.65	QP
12	27.627	-4.01	13.00	8.99	50.00	-41.01	AVG

5.3 Radiated Emission

5.3.1 Limits

Frequencies (MHz)	Field Strength (micovolts/meter)	Measurement Distance (meters)
0.009~0.490	2400/F(KHz)	300
0.490~1.705	24000/F(KHz)	30
1.705~30.0	30	30
30~88	100	3
88~216	150	3
216~960	200	3
Above 960	500	3

Receiver Parameter	Setting
Attenuation	Auto
Start ~ Stop Frequency	9kHz~150kHz / RB 200Hz for QP
Start ~ Stop Frequency	150kHz~30MHz / RB 9kHz for QP
Start ~ Stop Frequency	30MHz~1000MHz / RB 120kHz for QP

5.3.2 Test Procedures

- a) The radiated emission tests were performed in the 3 meters.
- b) The EUT was placed on the top of a rotating table 0.8 meters above the ground. The table was rotated 360 degrees to determine the position of the highest radiation.
- c) The height of the test antenna shall vary between 1m to 4m. Both horizontal and vertical polarizations of the antenna are set to make the measurement.
- d) If the peak mode measured value compliance with and lower than quasi peak mode limit, the EUT shall be deemed to meet QP limits and then no additional QP mode measurement performed.
- e) If the peak mode measured value compliance with and lower than average mode limit, the EUT shall be deemed to meet average limits and then no additional average mode measurement performed.
- f) For the actual test configuration, please refer to the related item – EUT test photos.

5.3.3 Test Setup

Radiated Emission Test-Up Frequency Below 30MHz

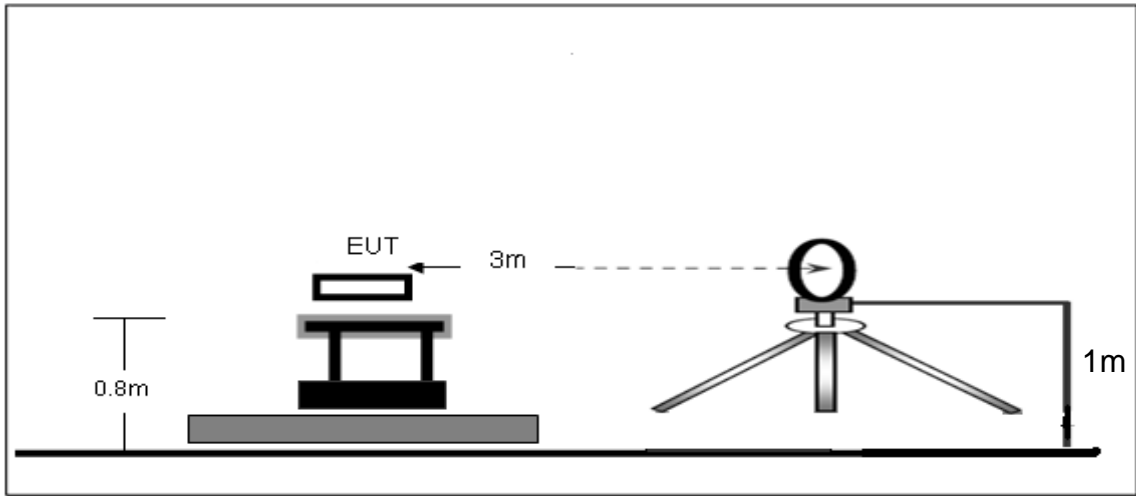

Radiated Emission Test-Up Frequency 30MHz~1GHz

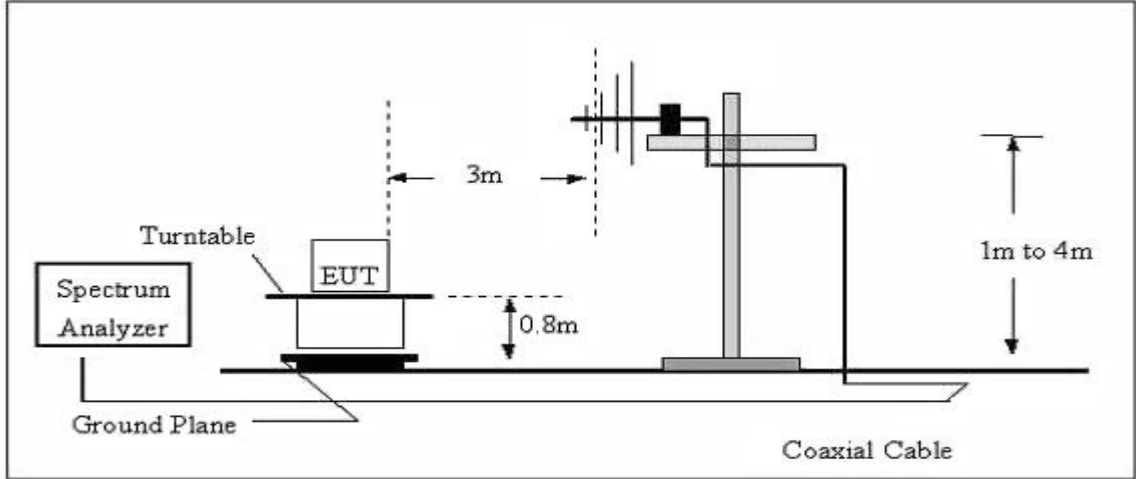

Radiated emission test-up frequency above 1GHz

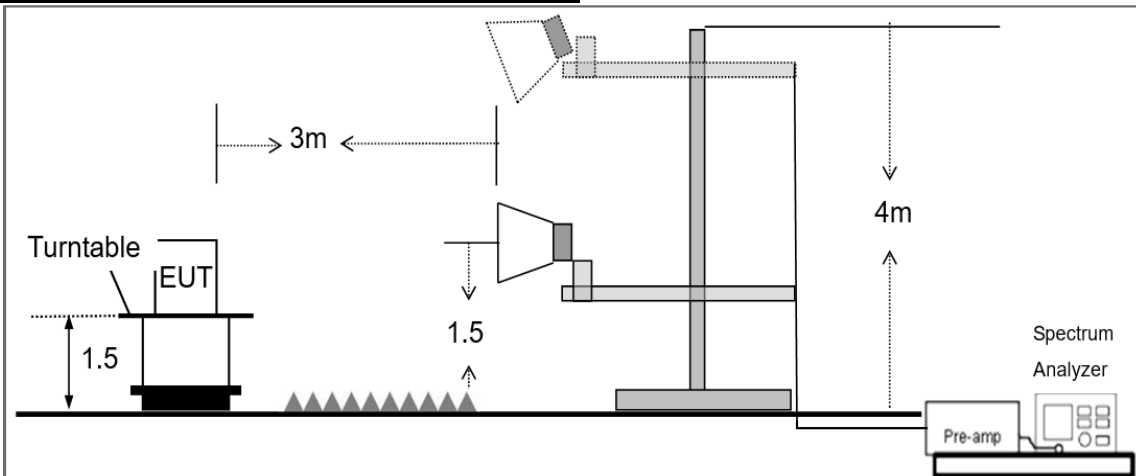

5.3.4 Test Result

Below 30MHz

EUT:	Wireless carplay adapter	Model Name:	KY-4165
Pressure:	1010 hPa	Test Voltage:	DC 5V from adapter AC 120V/60Hz
Test Mode:	TX	Polarization:	--

Freq.	Reading	Limit	Margin	State
(MHz)	(dBuV/m)	(dBuV/m)	(dB)	P/F
--	--	--	--	Pass
--	--	--	--	Pass

Note:

1. For 9kHz-30MHz, the amplitude of spurious emissions which are attenuated by more than 20dB below the permissible value has no need to be reported.
2. Distance extrapolation factor = $40 \log (\text{specific distance}/\text{test distance})$ (dB);
3. Limit line = specific limits (dBuV) + distance extrapolation factor.

30MHz – 1GHz

EUT:	Wireless carplay adapter	Model Name:	KY-4165
Test Mode:	TX	Phase:	Vertical
Test Voltage:	DC 5V from Adapter AC 120V/60Hz		

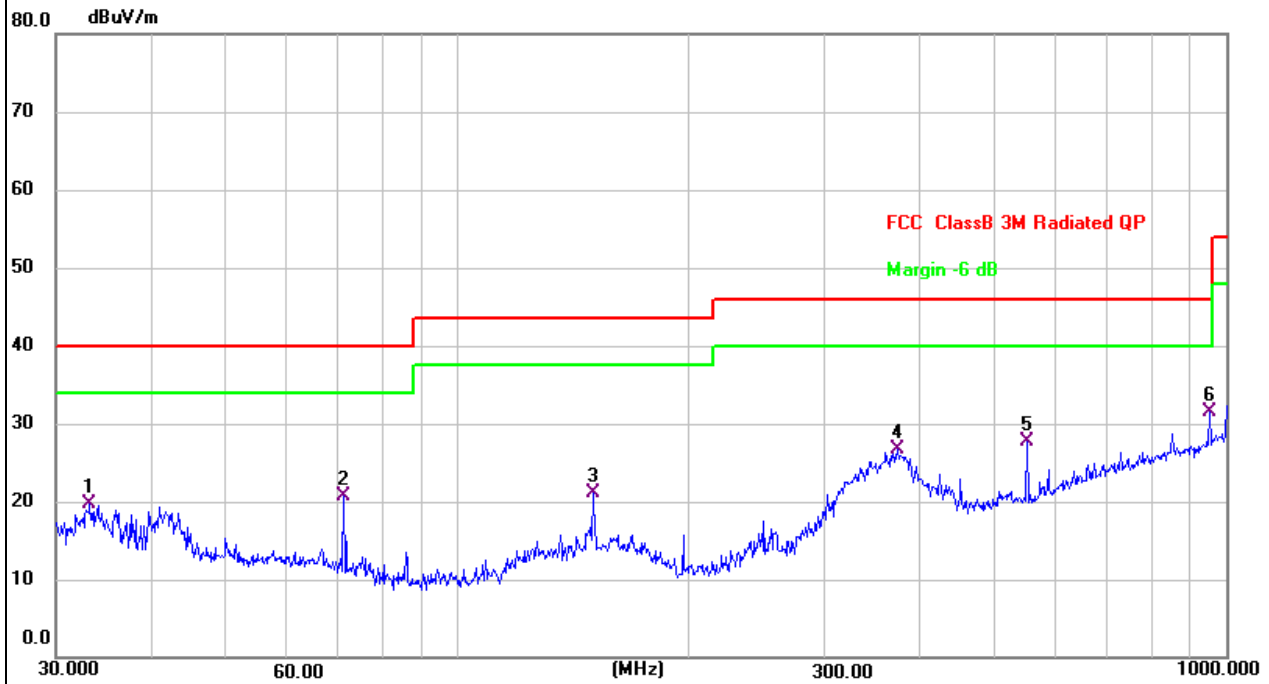

No.	Frequency (MHz)	Reading (dBuV)	Factor (dB/m)	Level (dBuV/m)	Limit (dBuV/m)	Margin (dB)	Detector
1	33.2112	34.71	-15.04	19.67	40.00	-20.33	QP
2	71.0803	36.80	-16.14	20.66	40.00	-19.34	QP
3	150.0108	34.66	-13.53	21.13	43.50	-22.37	QP
4	373.3112	37.16	-10.44	26.72	46.00	-19.28	QP
5	550.9480	34.29	-6.53	27.76	46.00	-18.24	QP
6 *	952.0937	30.09	1.36	31.45	46.00	-14.55	QP

EUT:	Wireless carplay adapter	Model Name:	KY-4165
Test Mode:	TX	Phase:	Horizontal
Test Voltage:	DC 5V from Adapter AC 120V/60Hz		

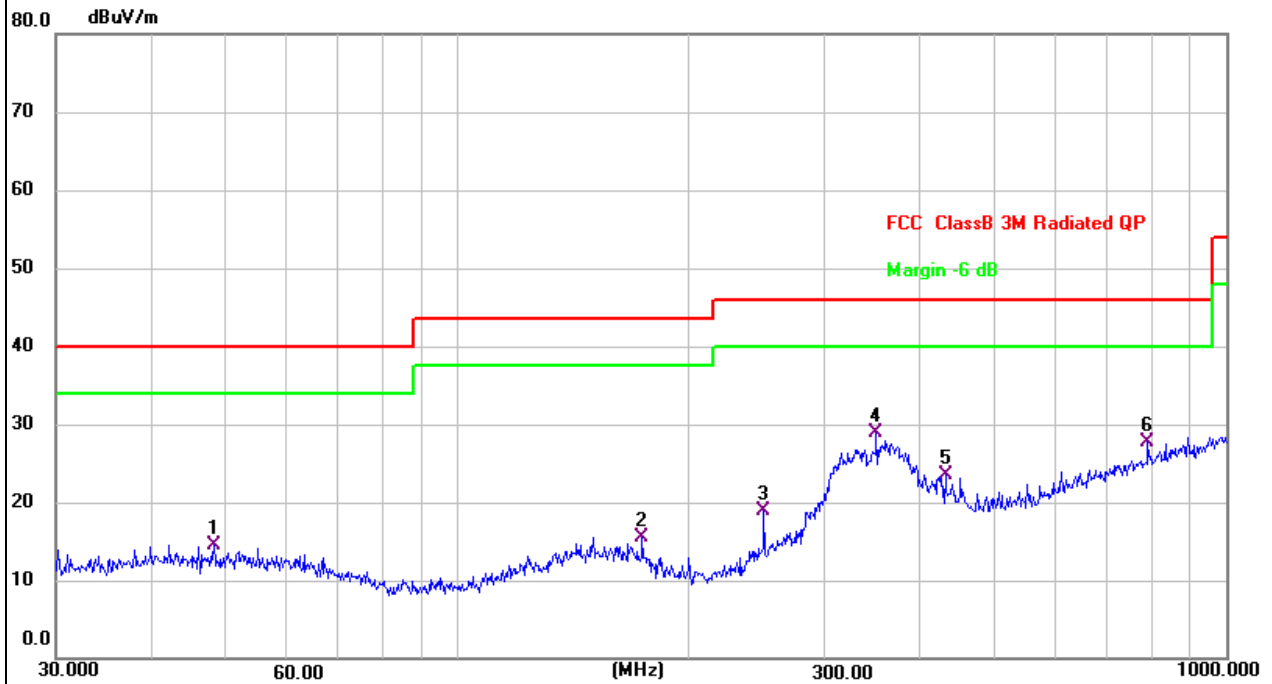

No.	Frequency (MHz)	Reading (dBuV)	Factor (dB/m)	Level (dBuV/m)	Limit (dBuV/m)	Margin (dB)	Detector
1	48.1626	28.89	-14.30	14.59	40.00	-25.41	QP
2	173.8135	29.49	-14.06	15.43	43.50	-28.07	QP
3	250.3012	33.77	-14.90	18.87	46.00	-27.13	QP
4 *	350.4768	40.07	-11.08	28.99	46.00	-17.01	QP
5	431.0316	32.12	-8.65	23.47	46.00	-22.53	QP
6	790.6188	28.34	-0.61	27.73	46.00	-18.27	QP

1GHz-25GHz

Frequency (MHz)	Read Level (dBμV)	Cable loss (dB)	Antenna Factor (dB/m)	Preamp Factor (dB)	Emission Level (dBμV/m)	Limits (dBμV/m)	Margin (dB)	Detector Type	Comment
Low Channel (2402 MHz)(8DPSK)--Above 1G									
4804.125	42.77	4.83	33.5	30.80	50.30	74.00	-23.70	Pk	Vertical
4804.125	31.69	4.83	33.5	30.80	39.22	54.00	-14.78	AV	Vertical
7206.261	42.74	5.83	37.79	31.40	54.96	74.00	-19.04	Pk	Vertical
7206.261	32.04	5.83	37.79	31.40	44.26	54.00	-9.74	AV	Vertical
4804.194	43.05	4.83	33.5	30.80	50.58	74.00	-23.42	Pk	Horizontal
4804.194	31.76	4.83	33.5	30.80	39.29	54.00	-14.71	AV	Horizontal
7206.274	42.79	5.83	37.79	31.40	55.01	74.00	-18.99	Pk	Horizontal
7206.274	32.03	5.83	37.79	31.40	44.25	54.00	-9.75	AV	Horizontal
Mid Channel (2441 MHz)(8DPSK)--Above 1G									
4882.139	44.22	4.89	33.76	30.80	52.07	74.00	-21.93	Pk	Vertical
4882.139	31.95	4.89	33.76	30.80	39.80	54.00	-14.20	AV	Vertical
7323.284	44.51	5.95	38.25	31.70	57.01	74.00	-16.99	Pk	Vertical
7323.284	32.99	5.95	38.25	31.70	45.49	54.00	-8.51	AV	Vertical
4882.215	43.80	4.89	33.76	30.80	51.65	74.00	-22.35	Pk	Horizontal
4882.215	32.08	4.89	33.76	30.80	39.93	54.00	-14.07	AV	Horizontal
7323.299	43.85	5.95	38.25	31.70	56.35	74.00	-17.65	Pk	Horizontal
7323.299	32.95	5.95	38.25	31.70	45.45	54.00	-8.55	AV	Horizontal
High Channel (2480 MHz)(8DPSK)-- Above 1G									
4960.143	42.85	4.95	34.33	30.80	51.33	74.00	-22.67	Pk	Vertical
4960.143	32.10	4.95	34.33	30.80	40.58	54.00	-13.42	AV	Vertical
7440.296	43.49	6.11	37.60	31.74	55.46	74.00	-18.54	Pk	Vertical
7440.296	32.27	6.11	37.60	31.74	44.24	54.00	-9.76	AV	Vertical
4960.245	42.91	4.95	34.33	30.80	51.39	74.00	-22.61	Pk	Horizontal
4960.245	32.05	4.95	34.33	30.80	40.53	54.00	-13.47	AV	Horizontal
7440.304	43.11	6.11	37.60	31.74	55.08	74.00	-18.92	Pk	Horizontal
7440.304	32.36	6.11	37.60	31.74	44.33	54.00	-9.67	AV	Horizontal

Note:

1. All Readings are Peak Value (VBW=3MHz) and AV Value (VBW=10Hz).
2. Emission Level= Antenna Factor + Cable Loss + Read Level - Preamp Factor.
3. All the modulation modes have been tested, and only the worst results are reflected in the report.

5.3.5 Radiated Band Edge

Frequency (MHz)	Read Level (dBμV)	Cable loss (dB)	Antenna Factor (dB/m)	Preamp Factor (dB)	Emission Level (dBμV/m)	Limits (dBμV/m)	Margin (dB)	Detector Type	Comment
3Mbps(8DPSK)- Non-hopping									
2310.00	46.11	3.40	27.80	32.41	44.90	74	-29.10	Pk	Horizontal
2310.00	33.52	3.40	27.80	32.41	32.31	54	-21.69	AV	Horizontal
2310.00	44.80	3.40	27.80	32.41	43.59	74	-30.41	Pk	Vertical
2310.00	33.68	3.40	27.80	32.41	32.47	54	-21.53	AV	Vertical
2390.00	45.66	3.45	27.70	32.49	44.32	74	-29.68	Pk	Vertical
2390.00	34.57	3.45	27.70	32.49	33.23	54	-20.77	AV	Vertical
2390.00	46.38	3.45	27.70	32.49	45.04	74	-28.96	Pk	Horizontal
2390.00	34.60	3.45	27.70	32.49	33.26	54	-20.74	AV	Horizontal
2400.00	46.60	3.46	27.80	32.54	45.32	74	-28.68	Pk	Vertical
2400.00	34.39	3.46	27.80	32.54	33.11	54	-20.89	AV	Vertical
2400.00	45.93	3.46	27.80	32.54	44.65	74	-29.35	Pk	Horizontal
2400.00	34.55	3.46	27.80	32.54	33.27	54	-20.73	AV	Horizontal
2483.50	47.21	3.48	28.53	32.55	46.67	74	-27.33	Pk	Vertical
2483.50	34.04	3.48	28.53	32.55	33.50	54	-20.50	AV	Vertical
2483.50	46.20	3.48	28.53	32.55	45.66	74	-28.34	Pk	Horizontal
2483.50	33.95	3.48	28.53	32.55	33.41	54	-20.59	AV	Horizontal
2500.00	45.54	3.49	29.20	32.66	45.57	74	-28.43	Pk	Vertical
2500.00	33.88	3.49	29.20	32.66	33.91	54	-20.09	AV	Vertical
2500.00	45.30	3.49	29.20	32.66	45.33	74	-28.67	Pk	Horizontal
2500.00	33.76	3.49	29.20	32.66	33.79	54	-20.21	AV	Horizontal
3Mbps (8DPSK)- hopping									
2400.00	47.08	3.46	27.80	32.54	45.80	74	-28.20	Pk	Vertical
2400.00	34.49	3.46	27.80	32.54	33.21	54	-20.79	AV	Vertical
2400.00	45.98	3.46	27.80	32.54	44.70	74	-29.30	Pk	Horizontal
2400.00	34.56	3.46	27.80	32.54	33.28	54	-20.72	AV	Horizontal
2483.50	47.40	3.48	28.53	32.55	46.86	74	-27.14	Pk	Vertical
2483.50	33.98	3.48	28.53	32.55	33.44	54	-20.56	AV	Vertical
2483.50	46.42	3.48	28.53	32.55	45.88	74	-28.12	Pk	Horizontal
2483.50	34.13	3.48	28.53	32.55	33.59	54	-20.41	AV	Horizontal

Note:

1. All Readings are Peak Value (VBW=3MHz) and AV Value (VBW=10Hz).
2. Emission Level= Antenna Factor + Cable Loss + Read Level - Preamp Factor.
3. All the modulation modes have been tested, and only the worst results are reflected in the report.

5.4 Peak Output Power

5.4.1 Limit

FCC Part15 Subpart C			
Section	Test Item	Limit	Frequency Range (MHz)
15.247(b)(1)	Peak output power	Power<1W(30dBm)	2400-2483.5

5.4.2 Test Procedure

- (1) The EUT was directly connected to the spectrum analyzer and antenna output port as show in the block diagram above.
- (2) Spectrum Setting:
RBW=2MHz, VBW=10MHz, Detector=Peak
- (3) The EUT was set to continuously transmitting in the max power during the test.

5.4.3 Test Setup

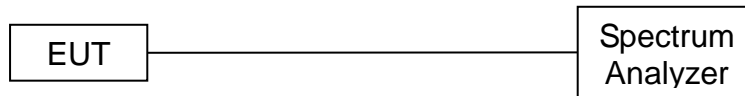

5.4.4 Test Results

EUT:	Wireless carplay adapter	Model Name:	KY-4165
Test Mode:	TX	Test Voltage:	DC 5V from adapter AC 120V/60Hz

GFSK

Test Channel	Frequency (MHz)	Maximum Peak Output Power(dBm)	Limit (dBm)
CH00	2402	1.82	30
CH39	2441	1.20	30
CH78	2480	0.99	30

$\pi/4$ -DQPSK

Test Channel	Frequency (MHz)	Maximum Peak Output Power(dBm)	Limit (dBm)
CH00	2402	1.95	21
CH39	2441	1.18	21
CH78	2480	1.38	21

8DPSK

Test Channel	Frequency (MHz)	Maximum Peak Output Power(dBm)	Limit (dBm)
CH00	2402	1.53	21
CH39	2441	1.28	21
CH78	2480	1.08	21

Test plots

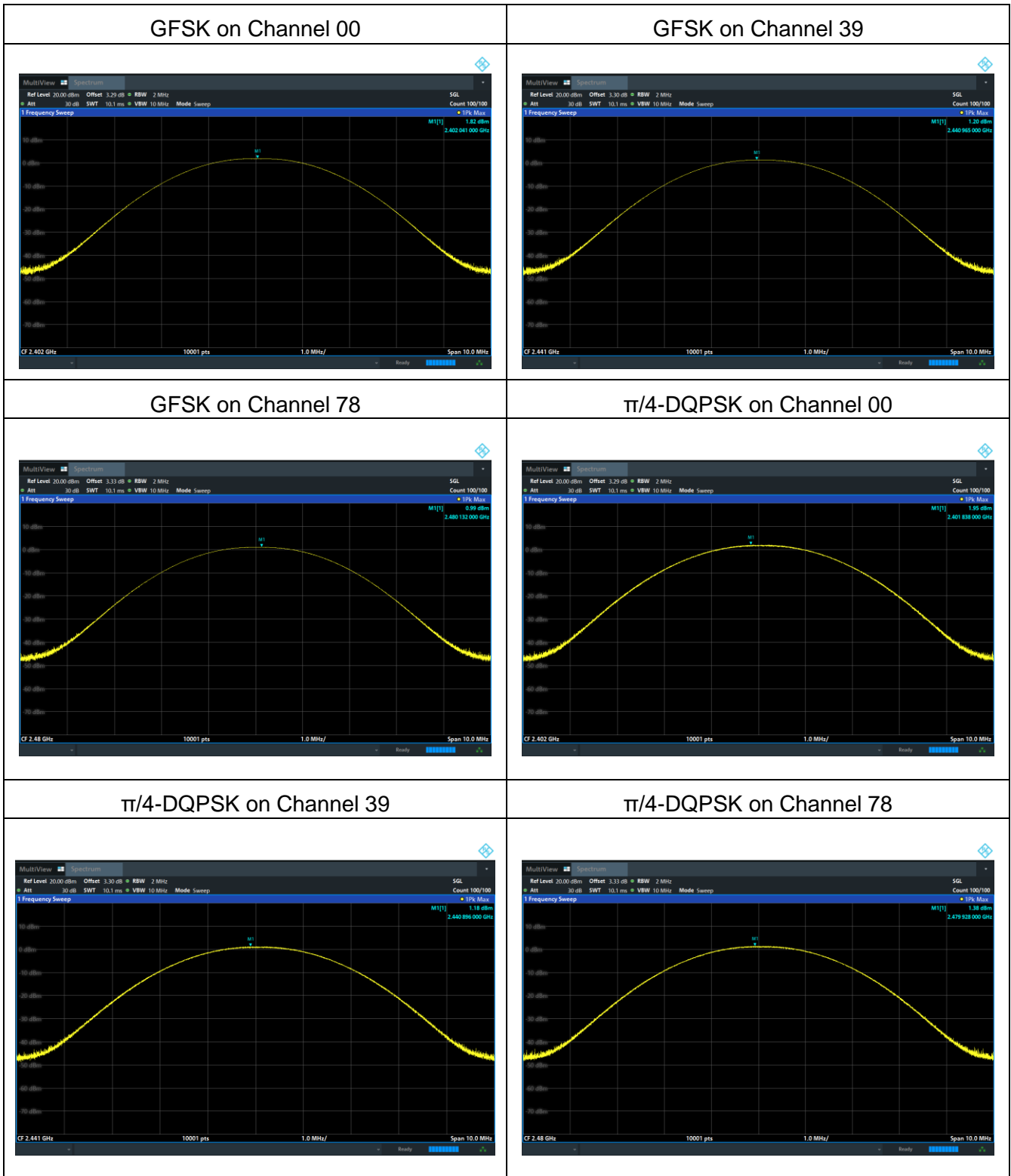

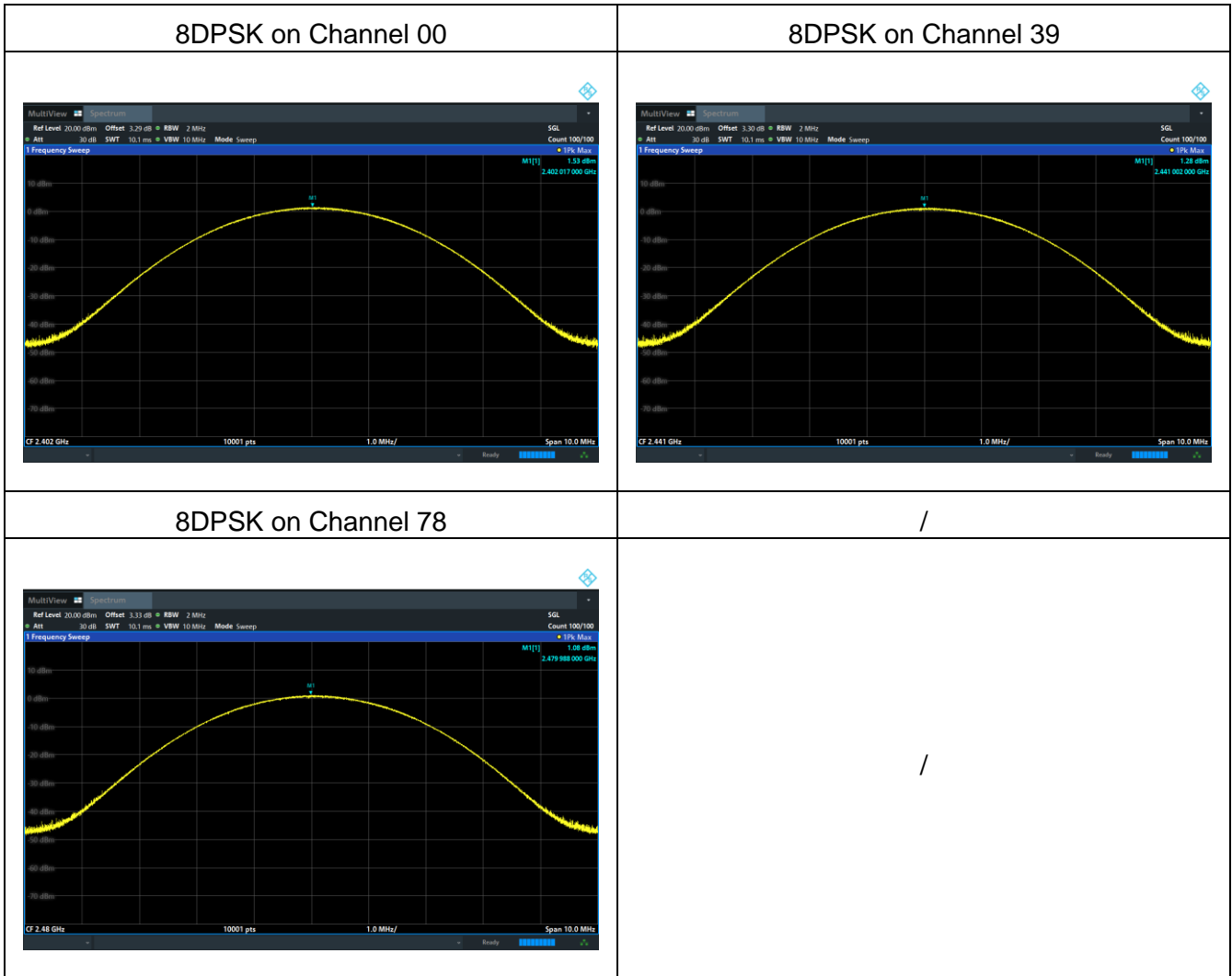

5.5 20dB Occupied Channel Bandwidth

5.5.1 Limit

FCC Part15 (15.247) , Subpart C			
Section	Test Item	Limit	Frequency Range (MHz)
15.247a(1)	20dB bandwidth	N/A	2400-2483.5

5.5.2 Test Procedure

- (1) The EUT was directly connected to the spectrum analyzer and antenna output port as show in the block diagram above.
- (2) Spectrum Setting:
Bandwidth: RBW=30 kHz, VBW=100 kHz, detector= Peak

5.5.3 Test Setup

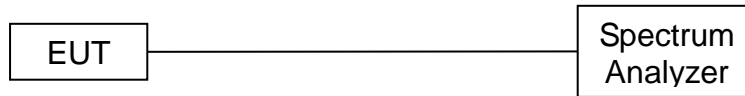

5.5.4 Test results

EUT:	Wireless carplay adapter	Model Name:	KY-4165
Test Mode:	TX	Test Voltage:	DC 5V from adapter AC 120V/60Hz

Mode	Frequency (MHz)	20dB Bandwidth (MHz)	Limit (MHz)	Result
GFSK	2402	0.958	N/A	Pass
	2441	0.956	N/A	Pass
	2480	0.957	N/A	Pass
$\pi/4$ -DQPSK	2402	1.36	N/A	Pass
	2441	1.361	N/A	Pass
	2480	1.36	N/A	Pass
8DPSK	2402	1.344	N/A	Pass
	2441	1.345	N/A	Pass
	2480	1.345	N/A	Pass

Test plots

GFSK mode

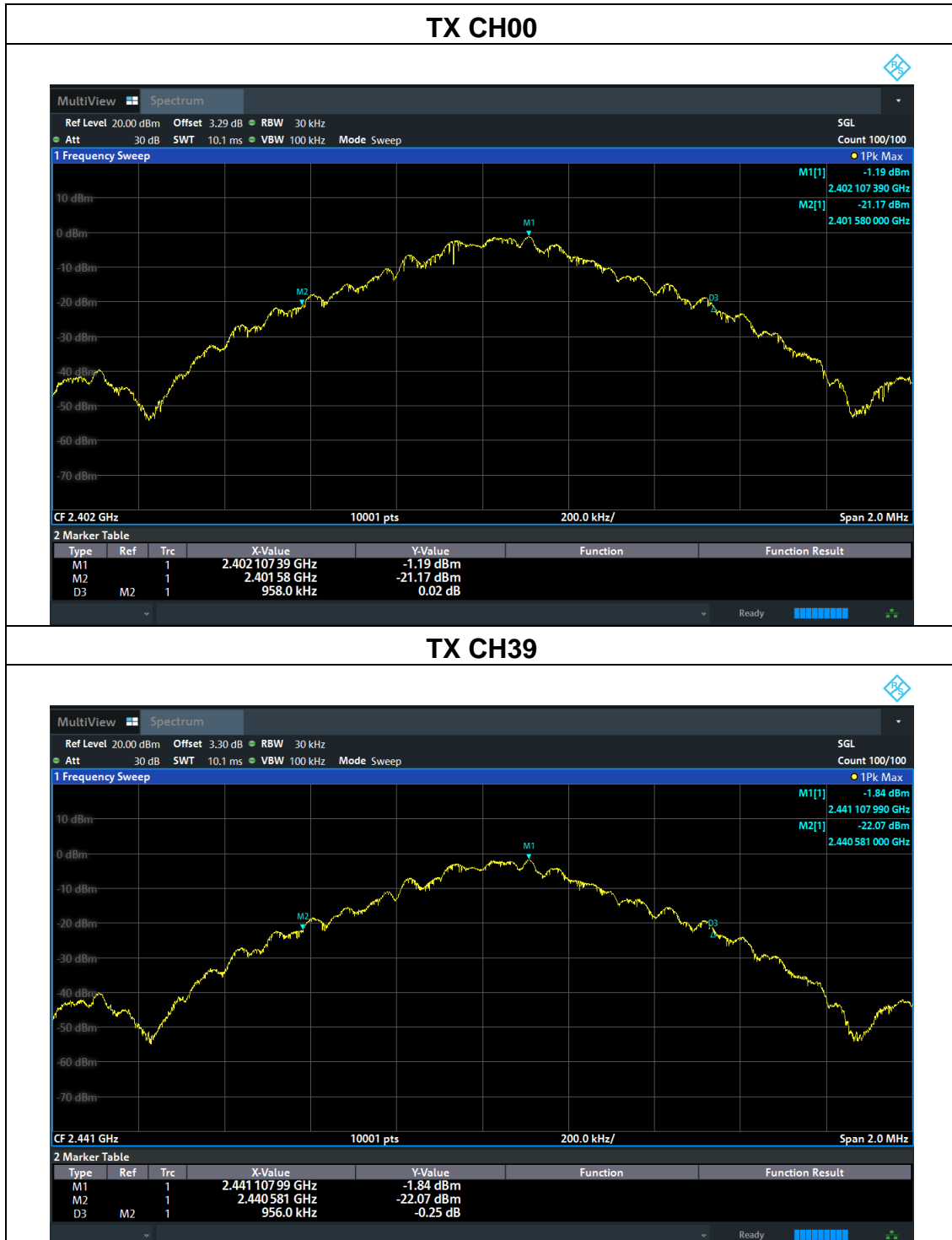

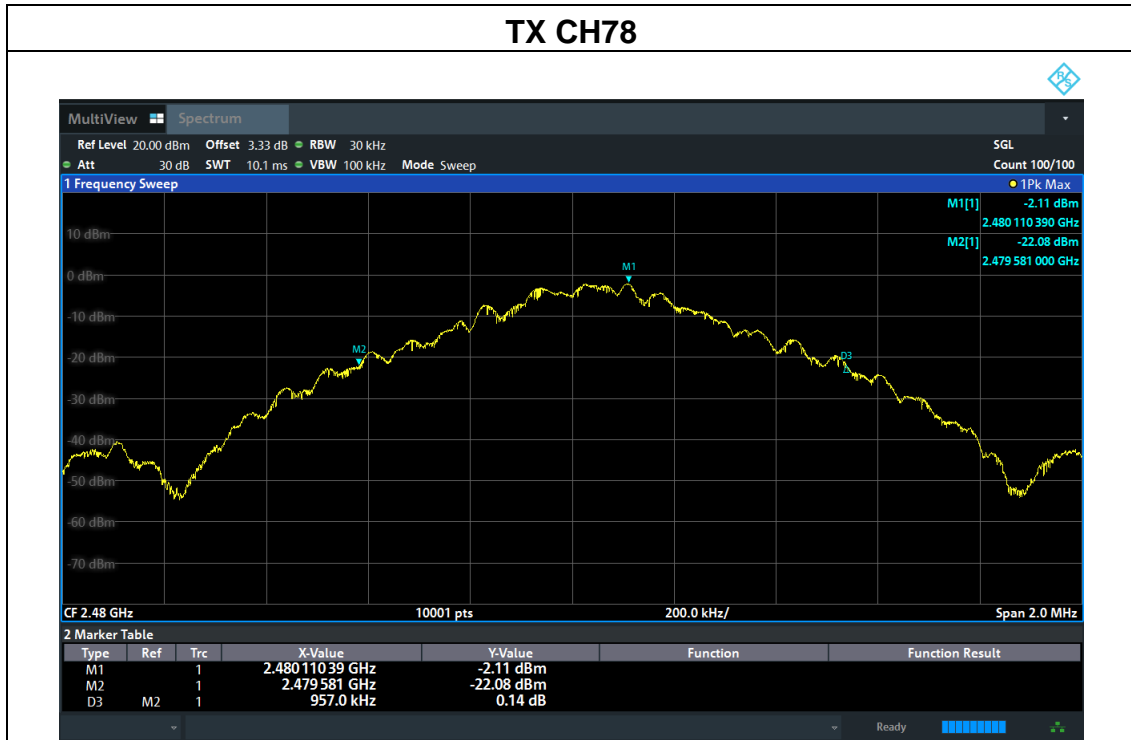

TX CH39



TX CH78



8DPSK mode

TX CH00

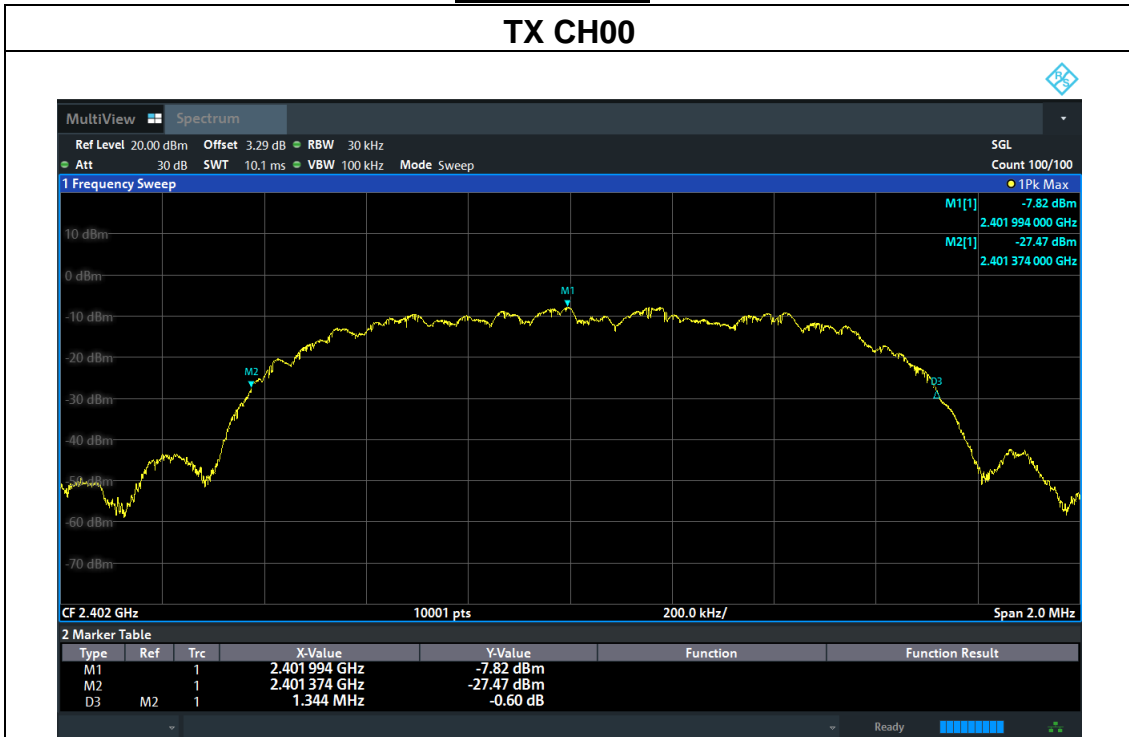

TX CH39

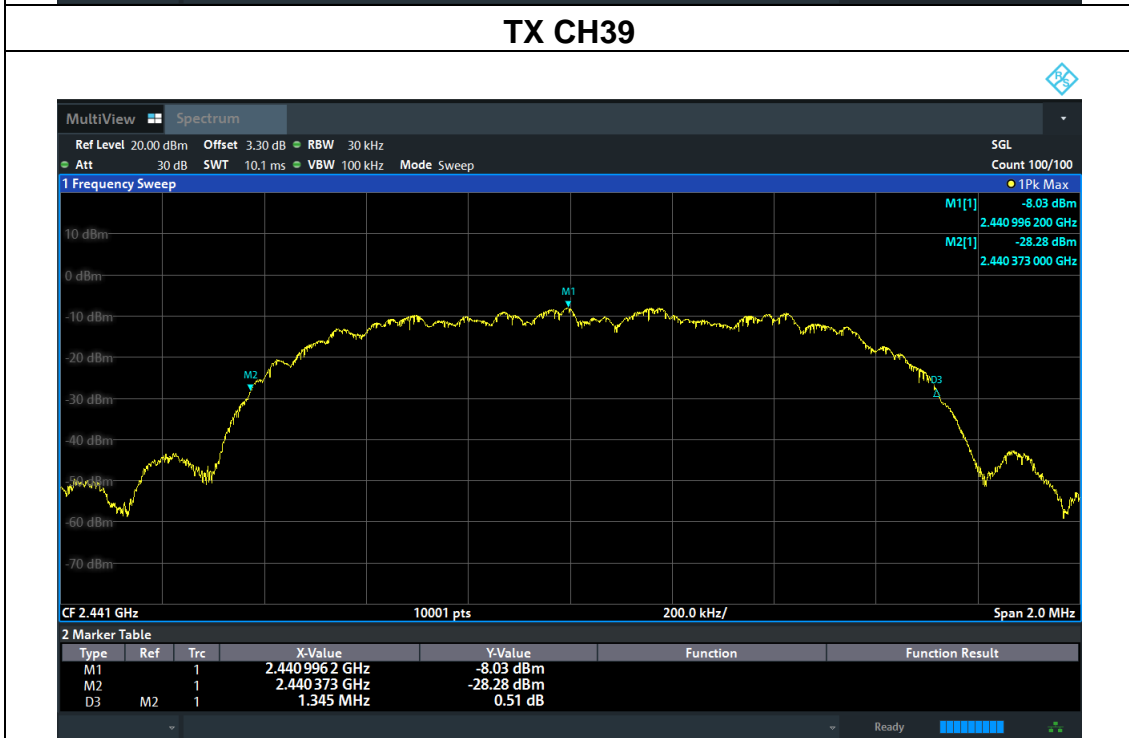

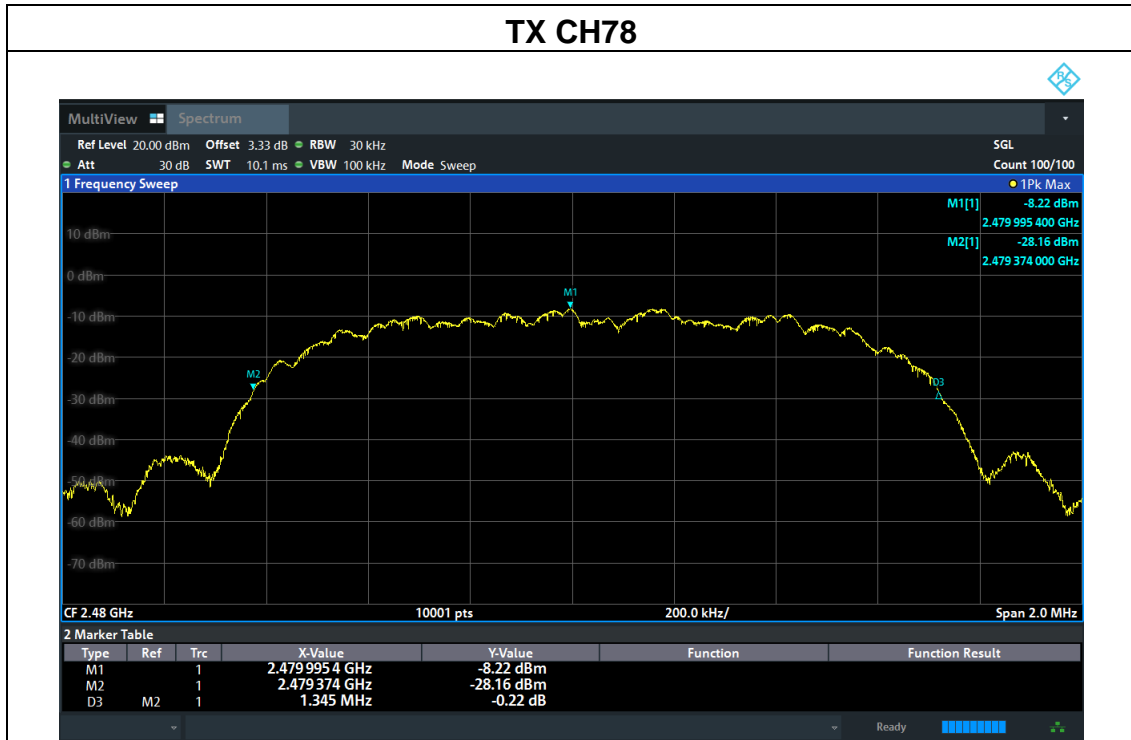

5.6 Carrier Frequency Separation

5.6.1 Limit

FCC Part15 (15.247) , Subpart C			
Section	Test Item	Limit	Frequency Range (MHz)
15.247(a)(1)	Channel Separation	>25kHz or >two-thirds of the 20 dB bandwidth (Which is greater)	2400-2483.5

5.6.2 Test Procedure

- (1) The EUT was directly connected to the spectrum analyzer and antenna output port as show in the block diagram above.
- (2) Spectrum Setting:
RBW=30 kHz, VBW=100 kHz, detector= Peak, Sweep Time =auto.
- (3) The EUT was set to the Hopping Mode for Channel Separation Test and continuously transmitting for the Test.

5.6.3 Test Setup

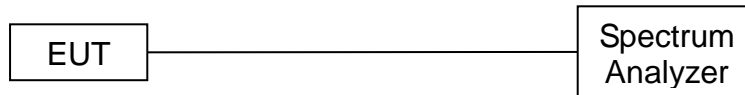

5.6.4 Test Results

EUT:	Wireless carplay adapter	Model Name:	KY-4165
Pressure:	1012 hPa	Test Voltage:	DC 5V from adapter AC 120V/60Hz
Test Mode:	GFSK, $\pi/4$ -DQPSK, 8DPSK /CH00, CH39, CH78		

Mode	Channel	Frequency (MHz)	Test Result (MHz)	Limit		Result
					(MHz)	
GFSK	Middle	2441	1.002	0.956	20dB BW	Pass
$\pi/4$ -DQPSK	Middle	2441	1.006	0.907	2/3 of 20dB BW	Pass
8DPSK	Middle	2441	1.002	0.897	2/3 of 20dB BW	Pass

Test plots

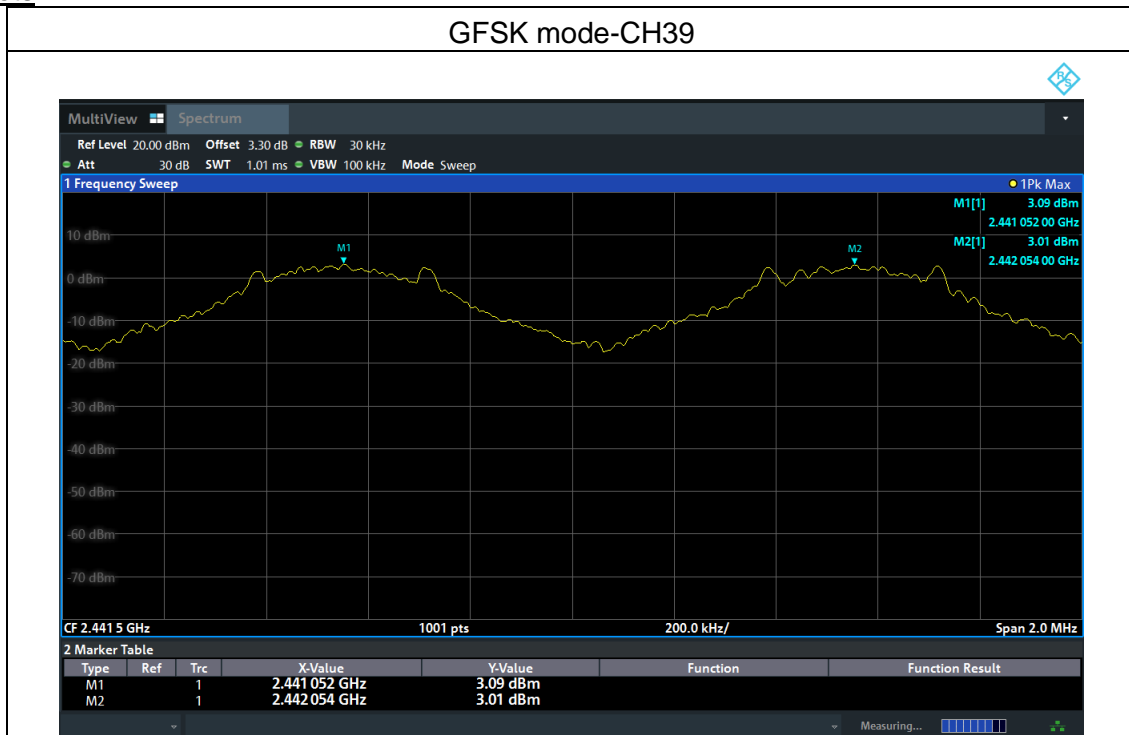

$\pi/4$ -DQPSK mode-CH39



8DPSK mode-CH39



5.7 Hopping Channel Number

5.7.1 Limit

Frequency hopping systems in the 2400-2483.5MHz band shall use at least 15 channels.

5.7.2 Test Procedure

The testing follows IEEE / ANSI C63.10-2020 clause 7.8.3

The RF output of EUT was connected to the spectrum analyzer by RF cable and attenuator.

The path loss was compensated to the results for each measurement.

Set to the maximum power setting and enable the EUT transmit continuously.

The EUT must have its hopping function enabled.

Use the following spectrum analyzer settings:

Span = the frequency band of operation

RBW : To identify clearly the individual channels, set the RBW to less than 30% of the channel spacing or the 20 dB bandwidth, whichever is smaller.

VBW \geq RBW

Sweep = auto

Detector function = peak

Trace = max hold

5.7.3 Test Setup

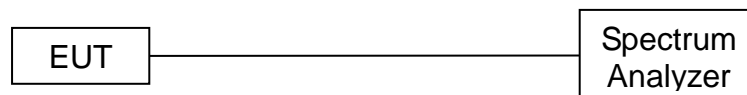

5.7.4 Test Results

Mode	Quantity of Hopping Channel	Limit	Results
GFSK, $\pi/4$ -DQPSK, 8DPSK	79	>15	Pass

Test plots



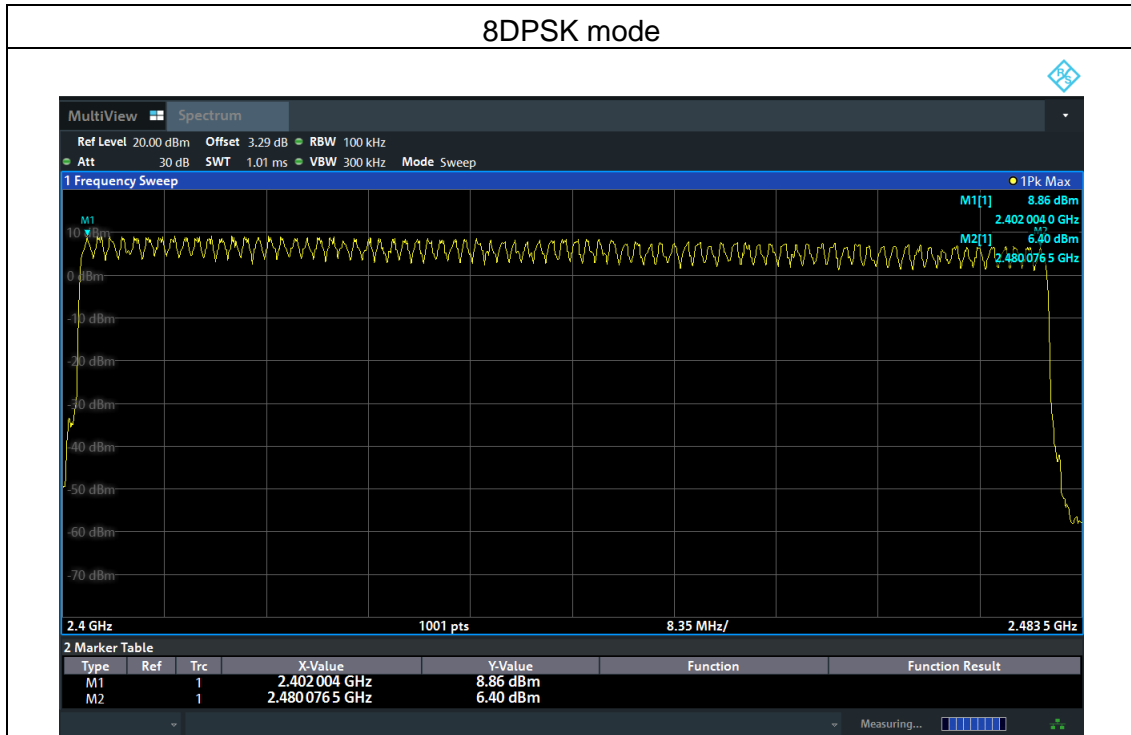

5.8 Dwell Time

5.8.1 Limit

FCC Part15 (15.247) , Subpart C			
Section	Test Item	Limit	Frequency Range (MHz)
15.247(a)(1)	Dwell time	0.4 sec	2400-2483.5

5.8.2 Test Procedure

- (1) The EUT was directly connected to the spectrum analyzer and antenna output port as show in the block diagram above.
- (2) Spectrum Setting: RBW=1MHz, VBW=3MHz, Span=0Hz, Detector=Peak
- (3) Use video trigger with the trigger level set to enable triggering only on full pulses.
- (4) Sweep Time is more than once pulse time.
- (5) Set the center frequency on any frequency would be measure and set the frequency span to zero span.
- (6) Measure the maximum time duration of one single pulse.
- (7) Set the EUT for packet transmitting.
- (8) Measure the maximum time duration of one single pulse.
- (9) The EUT was set to the Hopping Mode for Dwell Time Test.

5.8.3 Test Setup



5.8.4 Test Results

EUT:	Wireless carplay adapter	Model Name:	KY-4165
Pressure:	1012 hPa	Test Voltage:	DC 5V from adapter AC 120V/60Hz
Test Mode:	GFSK, $\pi/4$ -DQPSK, 8DPSK /CH39		

Mode	Data Packet	Frequency (MHz)	Pulse Duration (ms)	Dwell Time (ms)	Limit(s)	Conclusion
GFSK	DH1	2441	0.383	120.262	<0.4	Pass
	DH3	2441	1.639	254.045	<0.4	Pass
	DH5	2441	2.887	363.762	<0.4	Pass
$\pi/4$ -DQPSK	2DH1	2441	0.392	124.264	<0.4	Pass
	2DH3	2441	1.643	261.237	<0.4	Pass
	2DH5	2441	2.891	294.882	<0.4	Pass
8DPSK	3DH1	2441	0.391	123.556	<0.4	Pass
	3DH3	2441	1.642	247.942	<0.4	Pass
	3DH5	2441	2.894	312.552	<0.4	Pass

Note:

1. A period time = 0.4 (s) * 79 = 31.6(s)

2. DH1 time slot = Pulse Duration * (1600/(2*79)) * A period time

DH3 time slot = Pulse Duration * (1600/(4*79)) * A period time

DH5 time slot = Pulse Duration * (1600/(6*79)) * A period time

3. For GFSK, $\pi/4$ -DQPSK, 8DPSK: The test period: T= 0.4 Second/Channel x 79 Channel = 31.6 s

Test plots

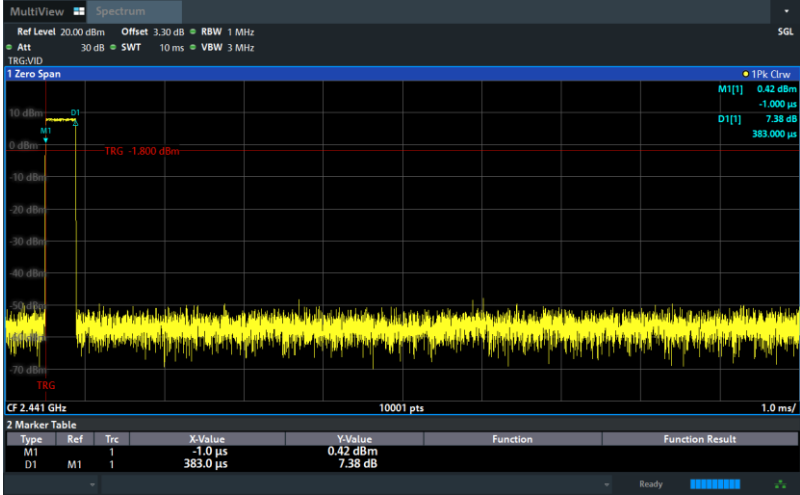
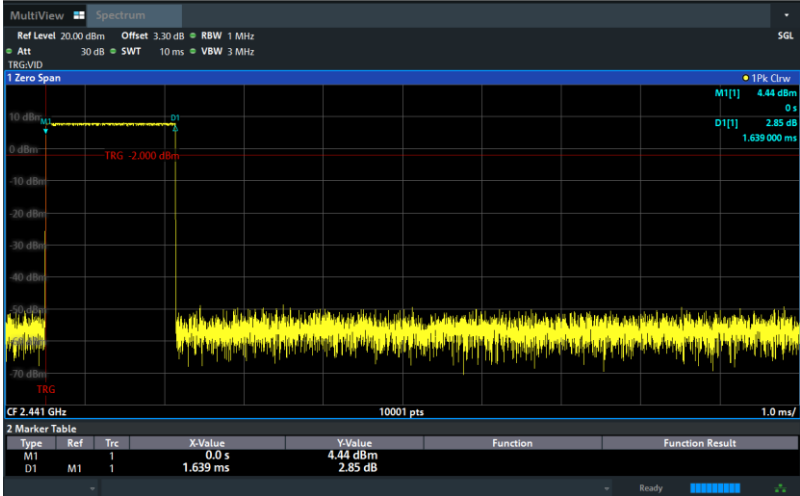
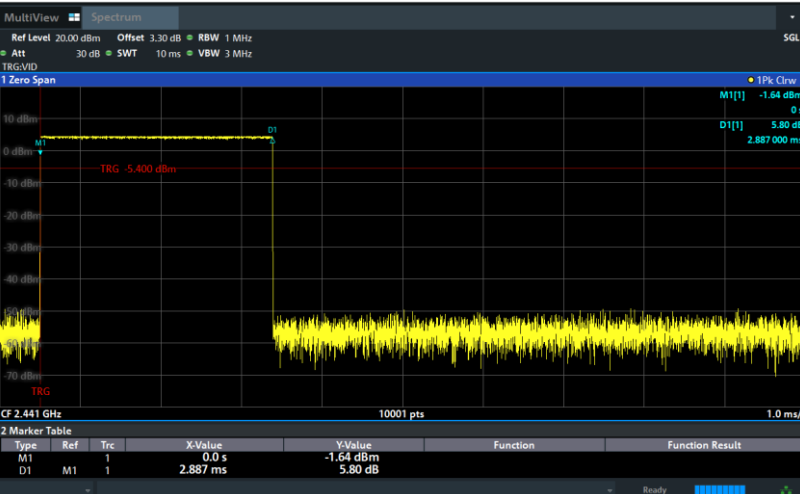
	Modulation mode	GFSK mode																					
DH1	 <p>MultiView Spectrum</p> <p>Ref Level 20.00 dBm Offset 3.30 dB RBW 1 MHz</p> <p>Att 30 dB SWT 10 ms VBW 3 MHz</p> <p>TRG:VID</p> <p>1 Zero Span</p> <p>1Pk Clrw</p> <p>M1[1] 0.42 dBm</p> <p>-1.000 μs</p> <p>D1[1] 7.38 dB</p> <p>383.000 μs</p> <p>TRG -1.800 dBm</p> <p>CF 2.441 GHz 10001 pts 1.0 ms/</p> <p>2 Marker Table</p> <table border="1"> <thead> <tr> <th>Type</th> <th>Ref</th> <th>Trc</th> <th>X-Value</th> <th>Y-Value</th> <th>Function</th> <th>Function Result</th> </tr> </thead> <tbody> <tr> <td>M1</td> <td>1</td> <td></td> <td>1.0 μs</td> <td>0.42 dBm</td> <td></td> <td></td> </tr> <tr> <td>D1</td> <td>M1</td> <td>1</td> <td>383.0 μs</td> <td>7.38 dB</td> <td></td> <td></td> </tr> </tbody> </table>		Type	Ref	Trc	X-Value	Y-Value	Function	Function Result	M1	1		1.0 μs	0.42 dBm			D1	M1	1	383.0 μs	7.38 dB		
Type	Ref	Trc	X-Value	Y-Value	Function	Function Result																	
M1	1		1.0 μs	0.42 dBm																			
D1	M1	1	383.0 μs	7.38 dB																			
DH3	 <p>MultiView Spectrum</p> <p>Ref Level 20.00 dBm Offset 3.30 dB RBW 1 MHz</p> <p>Att 30 dB SWT 10 ms VBW 3 MHz</p> <p>TRG:VID</p> <p>1 Zero Span</p> <p>1Pk Clrw</p> <p>M1[1] 4.44 dBm</p> <p>0 s</p> <p>D1[1] 2.85 dB</p> <p>1.639 000 ms</p> <p>TRG -2.000 dBm</p> <p>CF 2.441 GHz 10001 pts 1.0 ms/</p> <p>2 Marker Table</p> <table border="1"> <thead> <tr> <th>Type</th> <th>Ref</th> <th>Trc</th> <th>X-Value</th> <th>Y-Value</th> <th>Function</th> <th>Function Result</th> </tr> </thead> <tbody> <tr> <td>M1</td> <td>1</td> <td></td> <td>0.0 s</td> <td>4.44 dBm</td> <td></td> <td></td> </tr> <tr> <td>D1</td> <td>M1</td> <td>1</td> <td>1.639 ms</td> <td>2.85 dB</td> <td></td> <td></td> </tr> </tbody> </table>		Type	Ref	Trc	X-Value	Y-Value	Function	Function Result	M1	1		0.0 s	4.44 dBm			D1	M1	1	1.639 ms	2.85 dB		
Type	Ref	Trc	X-Value	Y-Value	Function	Function Result																	
M1	1		0.0 s	4.44 dBm																			
D1	M1	1	1.639 ms	2.85 dB																			
DH5	 <p>MultiView Spectrum</p> <p>Ref Level 20.00 dBm Offset 3.30 dB RBW 1 MHz</p> <p>Att 30 dB SWT 10 ms VBW 3 MHz</p> <p>TRG:VID</p> <p>1 Zero Span</p> <p>1Pk Clrw</p> <p>M1[1] -1.64 dBm</p> <p>0 s</p> <p>D1[1] 5.80 dB</p> <p>2.887 000 ms</p> <p>TRG -5.400 dBm</p> <p>CF 2.441 GHz 10001 pts 1.0 ms/</p> <p>2 Marker Table</p> <table border="1"> <thead> <tr> <th>Type</th> <th>Ref</th> <th>Trc</th> <th>X-Value</th> <th>Y-Value</th> <th>Function</th> <th>Function Result</th> </tr> </thead> <tbody> <tr> <td>M1</td> <td>1</td> <td></td> <td>0.0 s</td> <td>-1.64 dBm</td> <td></td> <td></td> </tr> <tr> <td>D1</td> <td>M1</td> <td>1</td> <td>2.887 ms</td> <td>5.80 dB</td> <td></td> <td></td> </tr> </tbody> </table>		Type	Ref	Trc	X-Value	Y-Value	Function	Function Result	M1	1		0.0 s	-1.64 dBm			D1	M1	1	2.887 ms	5.80 dB		
Type	Ref	Trc	X-Value	Y-Value	Function	Function Result																	
M1	1		0.0 s	-1.64 dBm																			
D1	M1	1	2.887 ms	5.80 dB																			

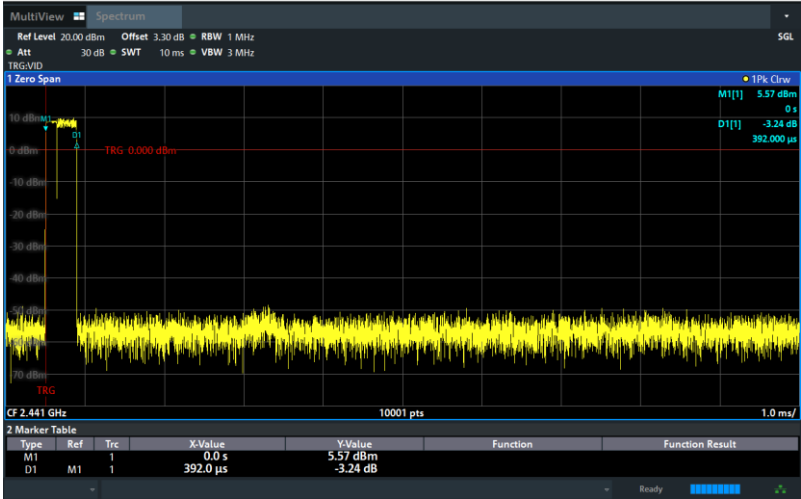
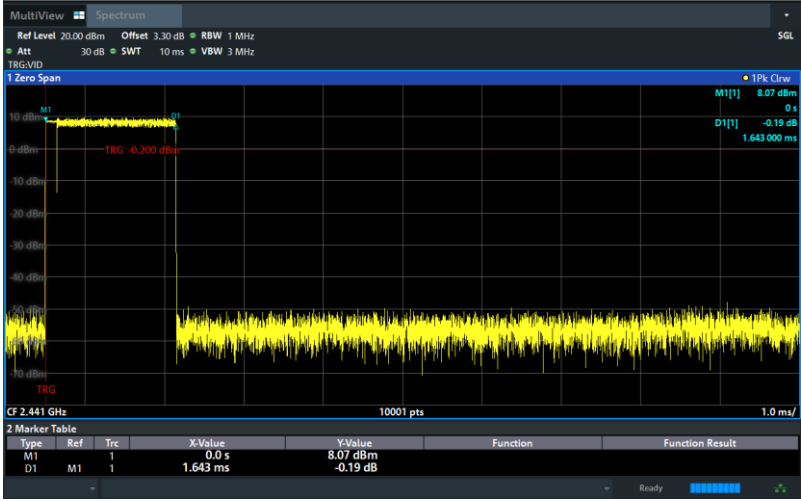
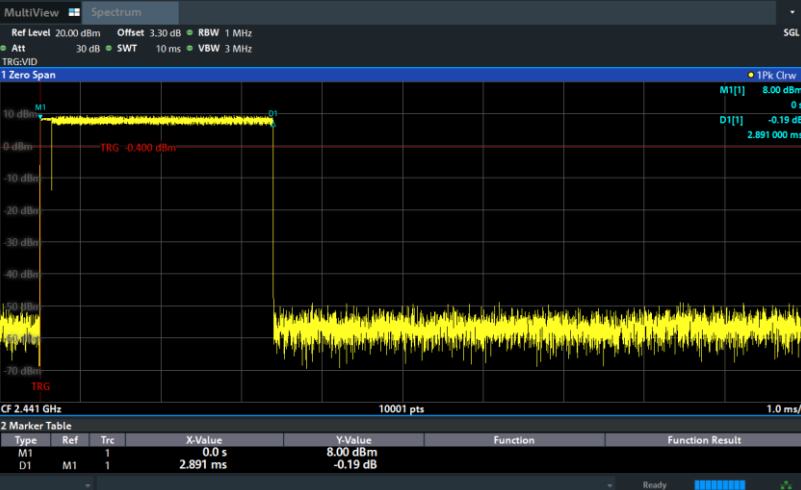
Modulation mode	$\pi/4$ -DQPSK mode																					
2-DH1	 <p>MultiView Spectrum Ref Level 20.00 dBm Offset 3.30 dB RBW 1 MHz Att 30 dB SWT 10 ms VBW 3 MHz TRG:VID 1 Zero Span 1Pk Clrw M1[1] 5.57 dBm 0 s D1[1] -3.24 dB 392.000 μs TRG CF 2.441 GHz 10001 pts 1.0 ms/</p> <table border="1"> <thead> <tr> <th>Type</th> <th>Ref</th> <th>Trc</th> <th>X-Value</th> <th>Y-Value</th> <th>Function</th> <th>Function Result</th> </tr> </thead> <tbody> <tr> <td>M1</td> <td>1</td> <td>1</td> <td>0.0 s</td> <td>5.57 dBm</td> <td></td> <td></td> </tr> <tr> <td>D1</td> <td>M1</td> <td>1</td> <td>392.0 μs</td> <td>-3.24 dB</td> <td></td> <td></td> </tr> </tbody> </table>	Type	Ref	Trc	X-Value	Y-Value	Function	Function Result	M1	1	1	0.0 s	5.57 dBm			D1	M1	1	392.0 μ s	-3.24 dB		
Type	Ref	Trc	X-Value	Y-Value	Function	Function Result																
M1	1	1	0.0 s	5.57 dBm																		
D1	M1	1	392.0 μ s	-3.24 dB																		
2-DH3	 <p>MultiView Spectrum Ref Level 20.00 dBm Offset 3.30 dB RBW 1 MHz Att 30 dB SWT 10 ms VBW 3 MHz TRG:VID 1 Zero Span 1Pk Clrw M1[1] 8.07 dBm 0 s D1[1] -0.19 dB 1.643 000 ms TRG CF 2.441 GHz 10001 pts 1.0 ms/</p> <table border="1"> <thead> <tr> <th>Type</th> <th>Ref</th> <th>Trc</th> <th>X-Value</th> <th>Y-Value</th> <th>Function</th> <th>Function Result</th> </tr> </thead> <tbody> <tr> <td>M1</td> <td>1</td> <td>1</td> <td>0.0 s</td> <td>8.07 dBm</td> <td></td> <td></td> </tr> <tr> <td>D1</td> <td>M1</td> <td>1</td> <td>1.643 ms</td> <td>-0.19 dB</td> <td></td> <td></td> </tr> </tbody> </table>	Type	Ref	Trc	X-Value	Y-Value	Function	Function Result	M1	1	1	0.0 s	8.07 dBm			D1	M1	1	1.643 ms	-0.19 dB		
Type	Ref	Trc	X-Value	Y-Value	Function	Function Result																
M1	1	1	0.0 s	8.07 dBm																		
D1	M1	1	1.643 ms	-0.19 dB																		
2-DH5	 <p>MultiView Spectrum Ref Level 20.00 dBm Offset 3.30 dB RBW 1 MHz Att 30 dB SWT 10 ms VBW 3 MHz TRG:VID 1 Zero Span 1Pk Clrw M1[1] 8.00 dBm 0 s D1[1] -0.19 dB 2.891 000 ms TRG CF 2.441 GHz 10001 pts 1.0 ms/</p> <table border="1"> <thead> <tr> <th>Type</th> <th>Ref</th> <th>Trc</th> <th>X-Value</th> <th>Y-Value</th> <th>Function</th> <th>Function Result</th> </tr> </thead> <tbody> <tr> <td>M1</td> <td>1</td> <td>1</td> <td>0.0 s</td> <td>8.00 dBm</td> <td></td> <td></td> </tr> <tr> <td>D1</td> <td>M1</td> <td>1</td> <td>2.891 ms</td> <td>-0.19 dB</td> <td></td> <td></td> </tr> </tbody> </table>	Type	Ref	Trc	X-Value	Y-Value	Function	Function Result	M1	1	1	0.0 s	8.00 dBm			D1	M1	1	2.891 ms	-0.19 dB		
Type	Ref	Trc	X-Value	Y-Value	Function	Function Result																
M1	1	1	0.0 s	8.00 dBm																		
D1	M1	1	2.891 ms	-0.19 dB																		

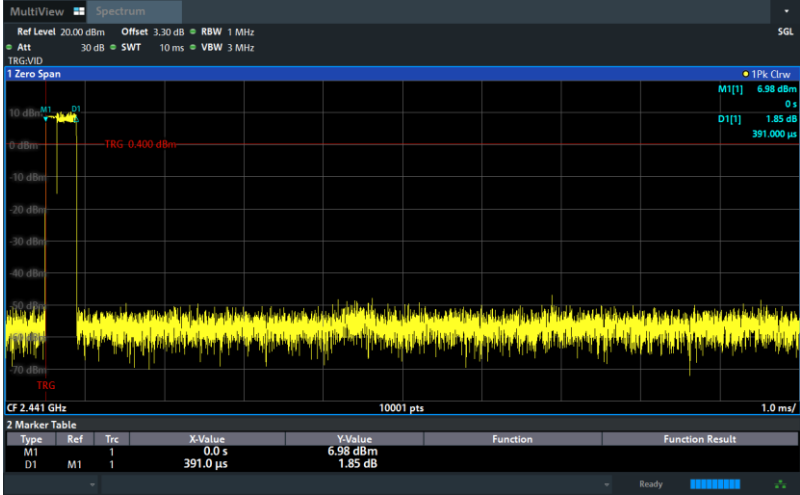
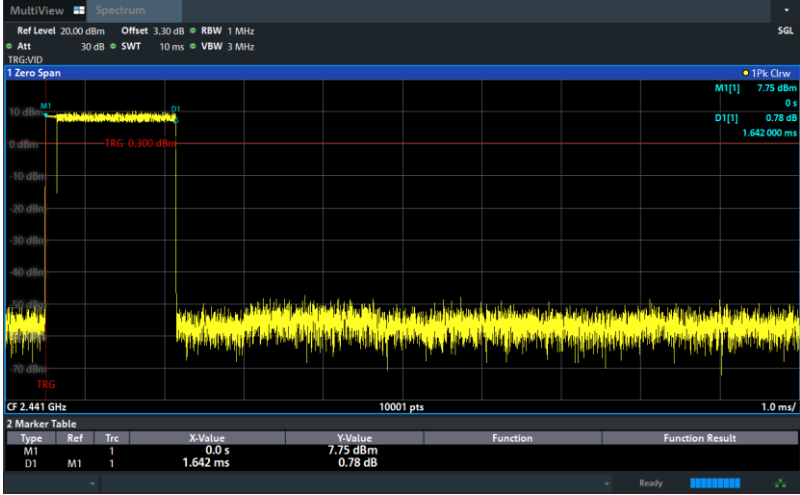
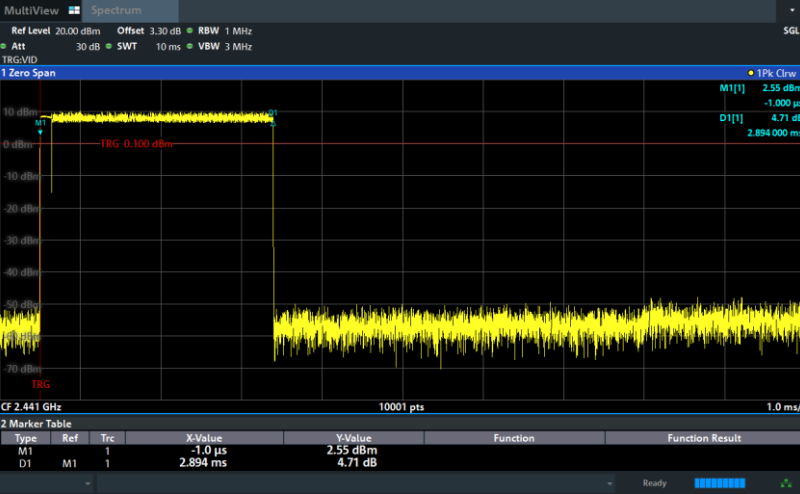
Modulation mode	8DPSK mode																					
3-DH1	 <p>MultiView Spectrum</p> <p>Ref Level 20.00 dBm Offset 3.30 dB RBW 1 MHz</p> <p>Att 30 dB SWT 10 ms VBW 3 MHz</p> <p>TRG:VID</p> <p>1 Zero Span</p> <p>1Pk Clrw</p> <p>M1[1] 6.98 dBm</p> <p>D1[1] 1.85 dB</p> <p>391.000 μs</p> <p>TRG 0.400 dBm</p> <p>CF 2.441 GHz</p> <p>10001 pts 1.0 ms/</p> <p>2 Marker Table</p> <table border="1"> <thead> <tr> <th>Type</th> <th>Ref</th> <th>Trc</th> <th>X-Value</th> <th>Y-Value</th> <th>Function</th> <th>Function Result</th> </tr> </thead> <tbody> <tr> <td>M1</td> <td>1</td> <td></td> <td>0.0 s</td> <td>6.98 dBm</td> <td></td> <td></td> </tr> <tr> <td>D1</td> <td>M1</td> <td>1</td> <td>391.0 μs</td> <td>1.85 dB</td> <td></td> <td></td> </tr> </tbody> </table>	Type	Ref	Trc	X-Value	Y-Value	Function	Function Result	M1	1		0.0 s	6.98 dBm			D1	M1	1	391.0 μs	1.85 dB		
Type	Ref	Trc	X-Value	Y-Value	Function	Function Result																
M1	1		0.0 s	6.98 dBm																		
D1	M1	1	391.0 μs	1.85 dB																		
3-DH3	 <p>MultiView Spectrum</p> <p>Ref Level 20.00 dBm Offset 3.30 dB RBW 1 MHz</p> <p>Att 30 dB SWT 10 ms VBW 3 MHz</p> <p>TRG:VID</p> <p>1 Zero Span</p> <p>1Pk Clrw</p> <p>M1[1] 7.75 dBm</p> <p>D1[1] 0.78 dB</p> <p>1.642 000 ms</p> <p>TRG 0.300 dBm</p> <p>CF 2.441 GHz</p> <p>10001 pts 1.0 ms/</p> <p>2 Marker Table</p> <table border="1"> <thead> <tr> <th>Type</th> <th>Ref</th> <th>Trc</th> <th>X-Value</th> <th>Y-Value</th> <th>Function</th> <th>Function Result</th> </tr> </thead> <tbody> <tr> <td>M1</td> <td>1</td> <td></td> <td>0.0 s</td> <td>7.75 dBm</td> <td></td> <td></td> </tr> <tr> <td>D1</td> <td>M1</td> <td>1</td> <td>1.642 ms</td> <td>0.78 dB</td> <td></td> <td></td> </tr> </tbody> </table>	Type	Ref	Trc	X-Value	Y-Value	Function	Function Result	M1	1		0.0 s	7.75 dBm			D1	M1	1	1.642 ms	0.78 dB		
Type	Ref	Trc	X-Value	Y-Value	Function	Function Result																
M1	1		0.0 s	7.75 dBm																		
D1	M1	1	1.642 ms	0.78 dB																		
3-DH5	 <p>MultiView Spectrum</p> <p>Ref Level 20.00 dBm Offset 3.30 dB RBW 1 MHz</p> <p>Att 30 dB SWT 10 ms VBW 3 MHz</p> <p>TRG:VID</p> <p>1 Zero Span</p> <p>1Pk Clrw</p> <p>M1[1] 2.55 dBm</p> <p>D1[1] 4.71 dB</p> <p>2.894 000 ms</p> <p>TRG 0.100 dBm</p> <p>CF 2.441 GHz</p> <p>10001 pts 1.0 ms/</p> <p>2 Marker Table</p> <table border="1"> <thead> <tr> <th>Type</th> <th>Ref</th> <th>Trc</th> <th>X-Value</th> <th>Y-Value</th> <th>Function</th> <th>Function Result</th> </tr> </thead> <tbody> <tr> <td>M1</td> <td>1</td> <td></td> <td>-1.0 μs</td> <td>2.55 dBm</td> <td></td> <td></td> </tr> <tr> <td>D1</td> <td>M1</td> <td>1</td> <td>2.894 ms</td> <td>4.71 dB</td> <td></td> <td></td> </tr> </tbody> </table>	Type	Ref	Trc	X-Value	Y-Value	Function	Function Result	M1	1		-1.0 μs	2.55 dBm			D1	M1	1	2.894 ms	4.71 dB		
Type	Ref	Trc	X-Value	Y-Value	Function	Function Result																
M1	1		-1.0 μs	2.55 dBm																		
D1	M1	1	2.894 ms	4.71 dB																		

5.9 Conducted Band Edge

5.9.1 Limit

In any 100 kHz bandwidth outside the frequency band in which the spread spectrum or digitally modulated intentional radiator is operating, the radio frequency power that is produced by the intentional radiator shall be at least 20 dB below that in the 100 kHz bandwidth within the band that contains the highest level of the desired power, based on either an RF conducted or a radiated measurement, provided the transmitter demonstrates compliance with the peak conducted power limits. If the transmitter complies with the conducted power limits based on the use of RMS averaging over a time interval, as permitted under paragraph (b)(3) of this section, the attenuation required under this paragraph shall be 30 dB instead of 20 dB. Attenuation below the general limits specified in §15.209(a) is not required. In addition, radiated emissions which fall in the restricted bands, as defined in §15.205(a), must also comply with the radiated emission limits specified in §15.209(a) (see §15.205(c)).

5.9.2 Test Procedure

- a) Check the calibration of the measuring instrument using either an internal calibrator or a known signal from an external generator.
- b) Position the EUT without connection to measurement instrument. Turn on the EUT and connect its antenna terminal to measurement instrument via a low loss cable. Then set it to any one measured frequency within its operating range, and make sure the instrument is operated in its linear range.
- c) Set RBW to 100 kHz and VBW of spectrum analyzer to 300 kHz with a convenient frequency span including 100 kHz bandwidth from band edge.
- d) Measure the highest amplitude appearing on spectral display and set it as a reference level. Plot the graph with marking the highest point and edge frequency.
- e) Repeat above procedures until all measured frequencies were complete.

5.9.3 Test Setup

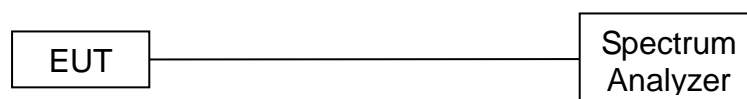

5.9.4 Test Results

EUT:	Wireless carplay adapter	Model Name:	KY-4165
Pressure:	1012 hPa	Test Voltage:	DC 5V from adapter AC 120V/60Hz

Test plots

GFSK: Band Edge, Left Side

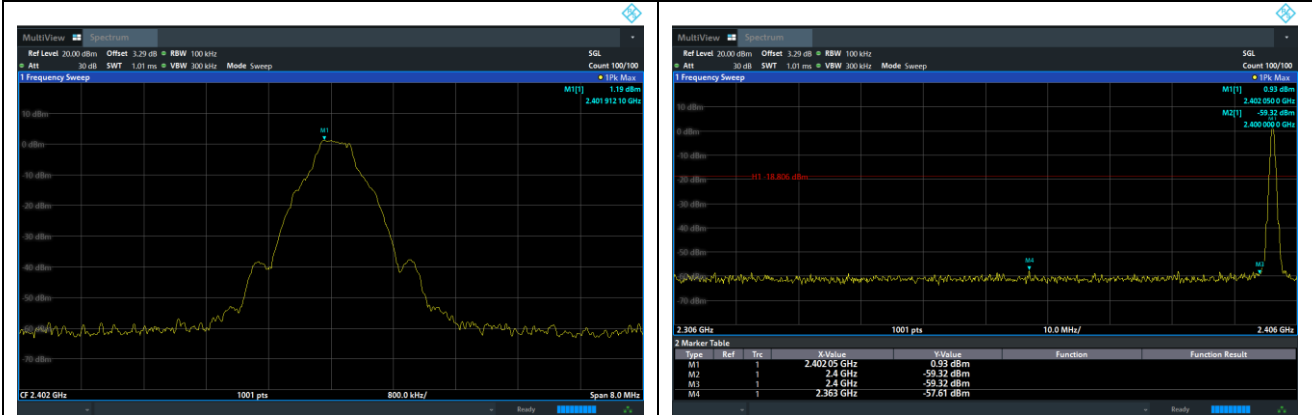

GFSK: Band Edge, Right Side

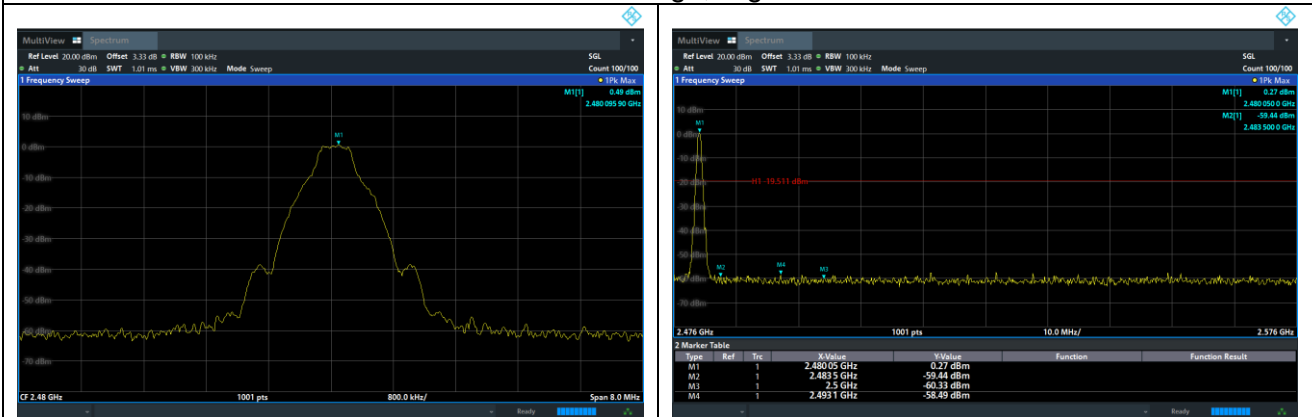

$\pi/4$ -DQPSK: Band Edge, Left Side



$\pi/4$ -DQPSK: Band Edge, Right Side

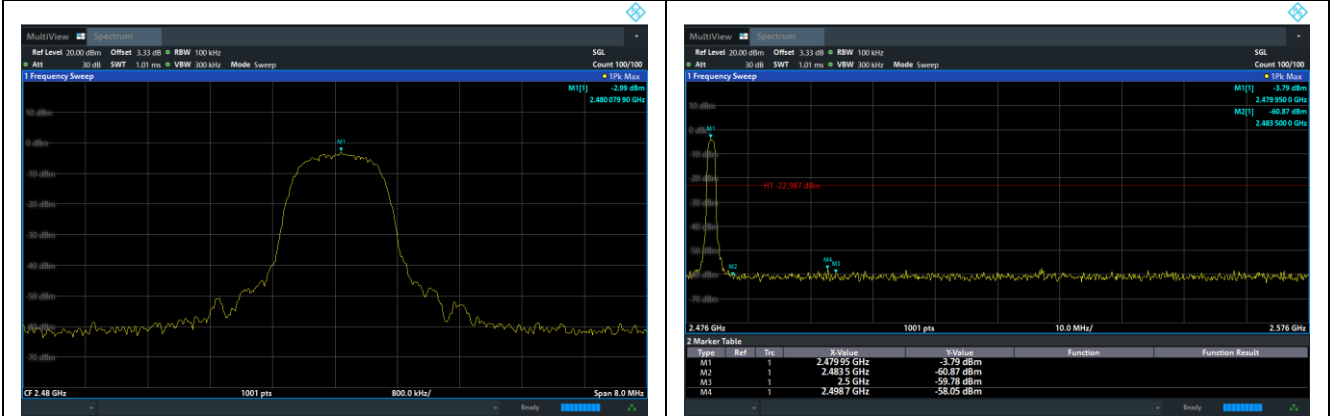

8DPSK: Band Edge, Left Side



8DPSK: Band Edge, Right Side

