

3.5.3 Test Setup

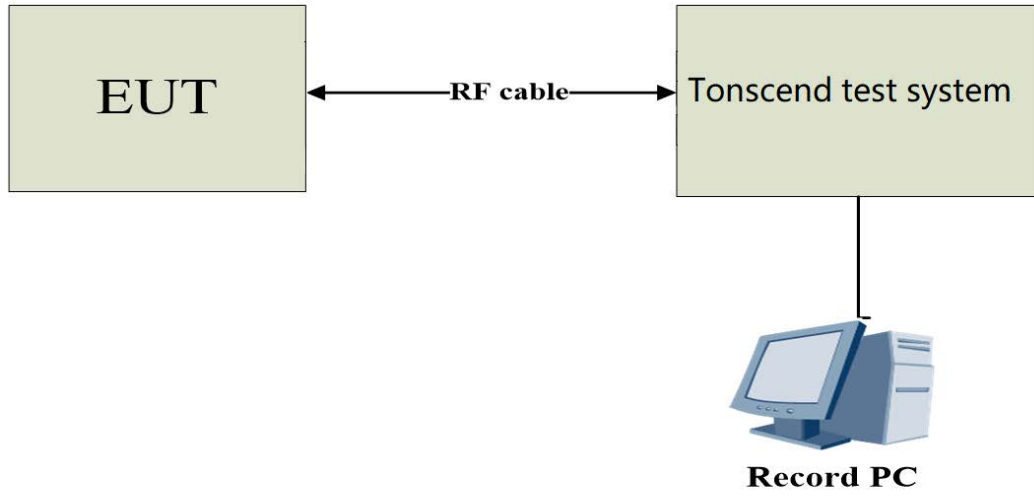

3.5.4 The Result

Test Mode	Antenna	Frequency[MHz]	Result [dBm/MHz]	Limit[dBm/MHz]	Verdict
11A	Ant1	5180	5.95	≤11.00	PASS
11A	Ant1	5200	6.58	≤11.00	PASS
11A	Ant1	5240	6.18	≤11.00	PASS
11A	Ant1	5260	6.45	≤11.00	PASS
11A	Ant1	5280	6.32	≤11.00	PASS
11A	Ant1	5320	5.69	≤11.00	PASS
11A	Ant1	5500	6.49	≤11.00	PASS
11A	Ant1	5580	7.23	≤11.00	PASS
11A	Ant1	5700	4.59	≤11.00	PASS
11A	Ant1	5745	2.27	≤30.00	PASS
11A	Ant1	5785	3.04	≤30.00	PASS
11A	Ant1	5825	3.36	≤30.00	PASS
11N20SISO	Ant1	5180	5.29	≤11.00	PASS
11N20SISO	Ant1	5200	5.73	≤11.00	PASS
11N20SISO	Ant1	5240	5.85	≤11.00	PASS
11N20SISO	Ant1	5260	5.19	≤11.00	PASS
11N20SISO	Ant1	5280	5.53	≤11.00	PASS
11N20SISO	Ant1	5320	4.96	≤11.00	PASS
11N20SISO	Ant1	5500	5.91	≤11.00	PASS
11N20SISO	Ant1	5580	6.28	≤11.00	PASS
11N20SISO	Ant1	5700	4.81	≤11.00	PASS
11N20SISO	Ant1	5745	2.64	≤30.00	PASS
11N20SISO	Ant1	5785	2.73	≤30.00	PASS
11N20SISO	Ant1	5825	2.87	≤30.00	PASS
11N40SISO	Ant1	5190	2.57	≤11.00	PASS
11N40SISO	Ant1	5230	2.99	≤11.00	PASS
11N40SISO	Ant1	5270	2.53	≤11.00	PASS
11N40SISO	Ant1	5310	3.15	≤11.00	PASS
11N40SISO	Ant1	5510	3.03	≤11.00	PASS
11N40SISO	Ant1	5550	3.27	≤11.00	PASS
11N40SISO	Ant1	5670	2.16	≤11.00	PASS
11N40SISO	Ant1	5755	-0.08	≤30.00	PASS
11N40SISO	Ant1	5795	-0.51	≤30.00	PASS
11AC20SISO	Ant1	5180	5.61	≤11.00	PASS
11AC20SISO	Ant1	5200	5.34	≤11.00	PASS
11AC20SISO	Ant1	5240	5.40	≤11.00	PASS
11AC20SISO	Ant1	5260	5.41	≤11.00	PASS
11AC20SISO	Ant1	5280	5.34	≤11.00	PASS
11AC20SISO	Ant1	5320	5.13	≤11.00	PASS
11AC20SISO	Ant1	5500	5.70	≤11.00	PASS

11AC20SISO	Ant1	5580	5.96	≤11.00	PASS
11AC20SISO	Ant1	5700	5.22	≤11.00	PASS
11AC20SISO	Ant1	5745	1.80	≤30.00	PASS
11AC20SISO	Ant1	5785	3.56	≤30.00	PASS
11AC20SISO	Ant1	5825	3.37	≤30.00	PASS
11AC40SISO	Ant1	5190	3.00	≤11.00	PASS
11AC40SISO	Ant1	5230	4.77	≤11.00	PASS
11AC40SISO	Ant1	5270	1.94	≤11.00	PASS
11AC40SISO	Ant1	5310	3.46	≤11.00	PASS
11AC40SISO	Ant1	5510	1.72	≤11.00	PASS
11AC40SISO	Ant1	5550	3.02	≤11.00	PASS
11AC40SISO	Ant1	5670	2.60	≤11.00	PASS
11AC40SISO	Ant1	5755	-0.44	≤30.00	PASS
11AC40SISO	Ant1	5795	0.31	≤30.00	PASS
11AC80SISO	Ant1	5210	2.10	≤11.00	PASS
11AC80SISO	Ant1	5290	-0.34	≤11.00	PASS
11AC80SISO	Ant1	5530	0.49	≤11.00	PASS
11AC80SISO	Ant1	5610	2.82	≤11.00	PASS
11AC80SISO	Ant1	5775	-1.54	≤30.00	PASS

Note: The Duty Cycle Factor and line loss are compensated in the test system

For UNII-3, according to KDB publication 789033 D02 General UNII Test Procedures New Rules v02r01, section II.F.5., it is acceptable to set RBW at 300kHz and VBW at 1500kHz if the spectrum analyzer does not have 500 kHz RBW. Then, add $10 \log(500 \text{ kHz}/300 \text{ kHz})$ to the measured result, i.e. 2.22 dB.

During the test of U-NII 3 PSD, the measurement result with RBW=300kHz has been added 2.22 dB by compensating offset, $\text{offset} = \text{cable loss} + \text{duty cycle factor} + 10 \log(500 \text{ kHz}/300 \text{ kHz})$.

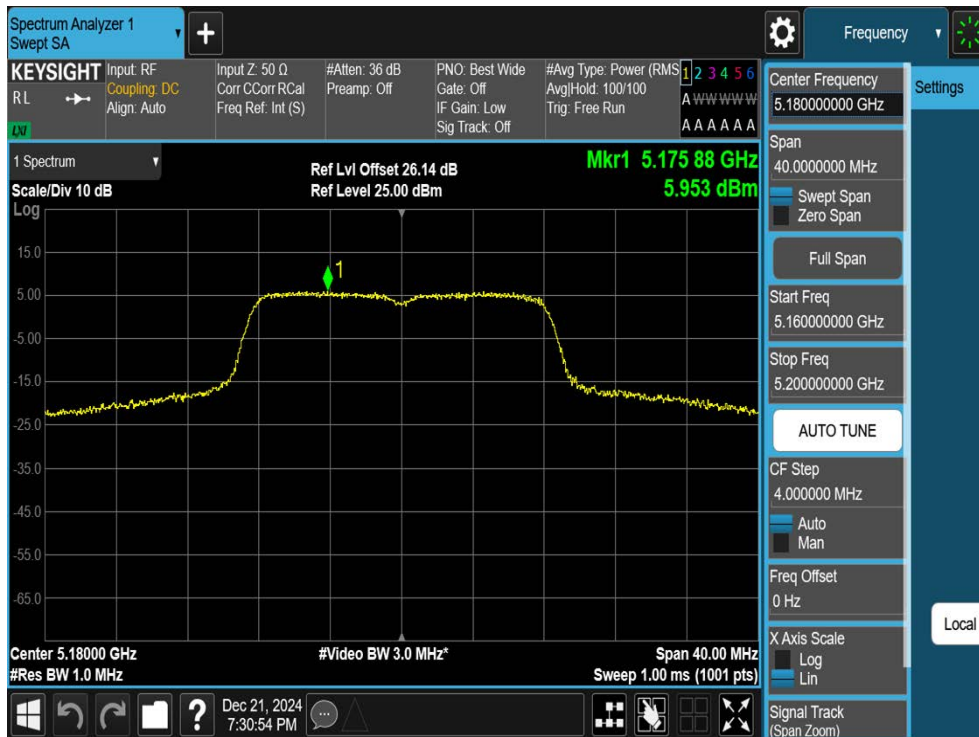

11A-Ant1-5180-PASS

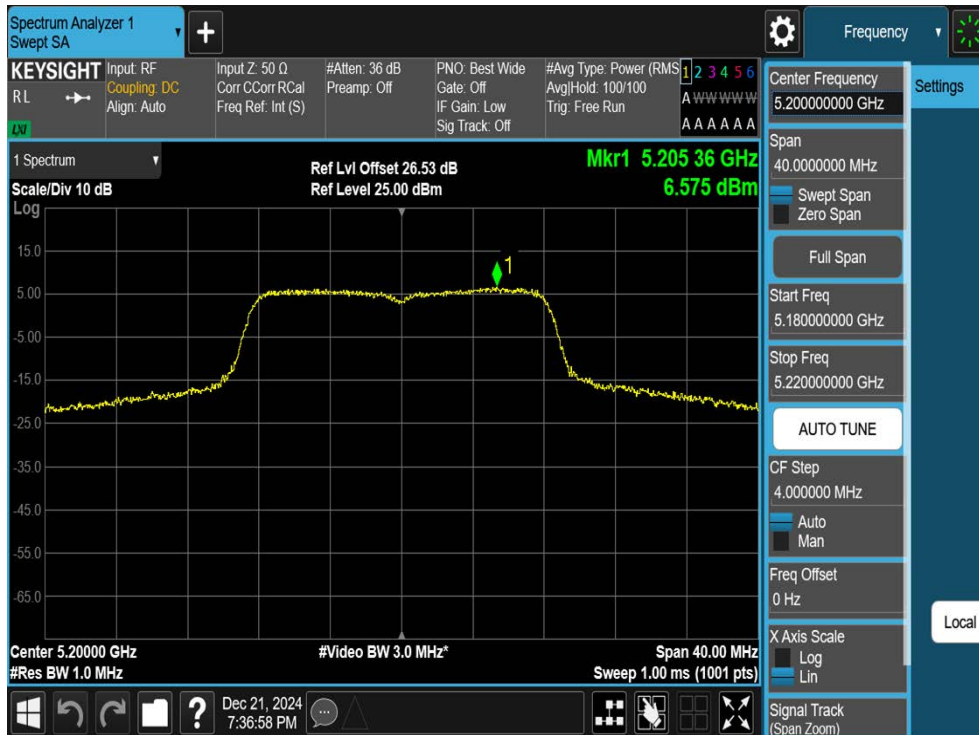

11A-Ant1-5200-PASS



11A-Ant1-5240-PASS

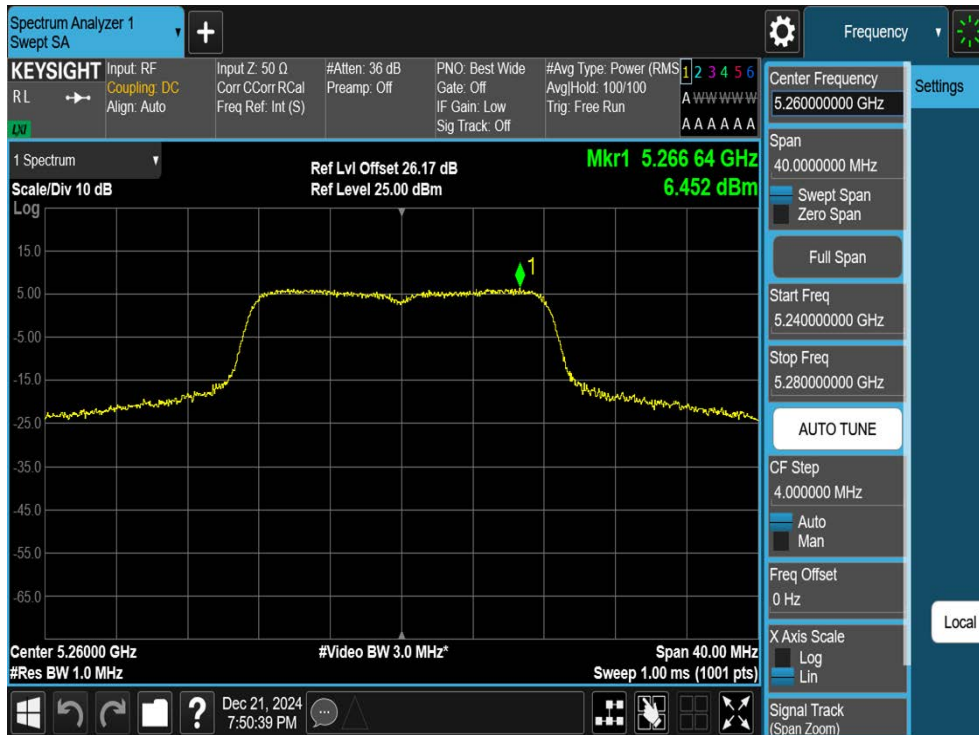

11A-Ant1-5260-PASS



11A-Ant1-5280-PASS



11A-Ant1-5320-PASS

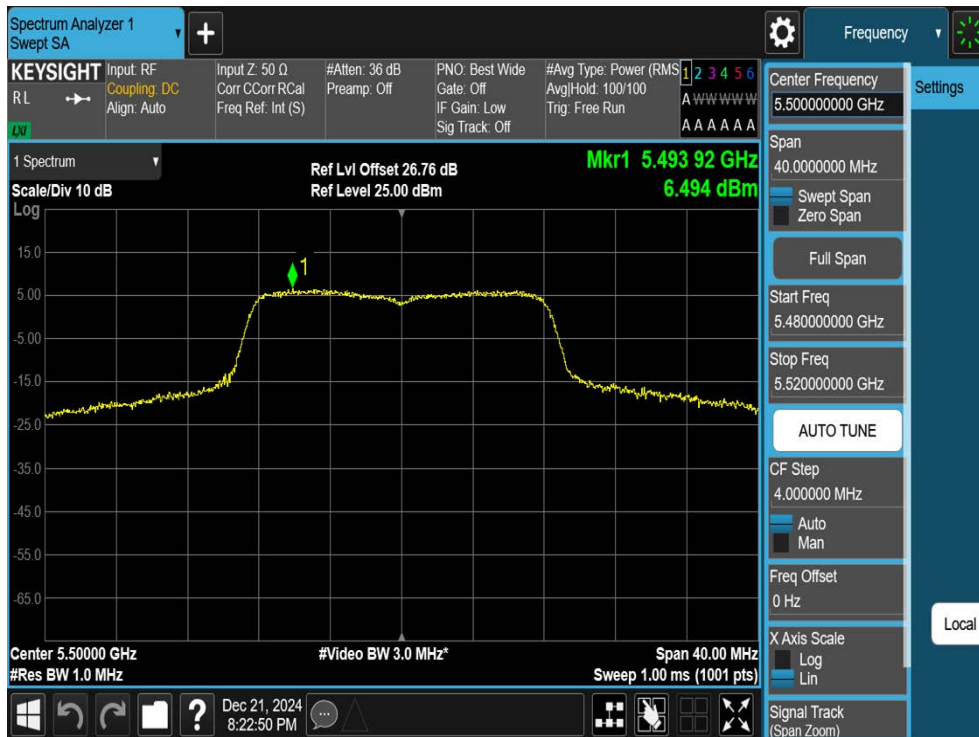

11A-Ant1-5500-PASS



11A-Ant1-5580-PASS

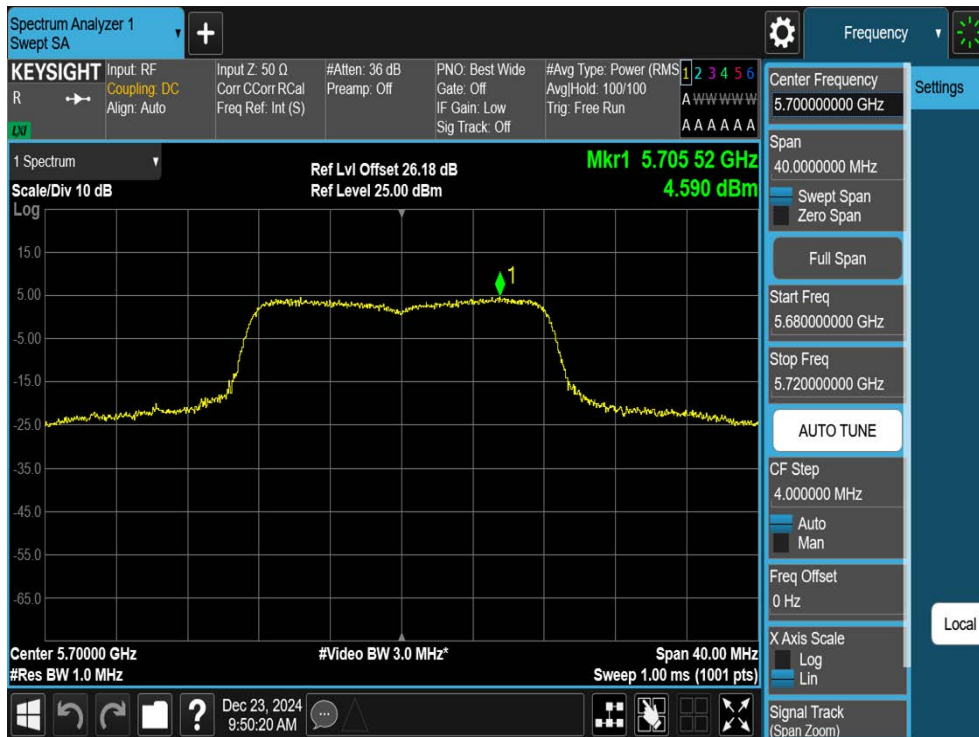

11A-Ant1-5700-PASS

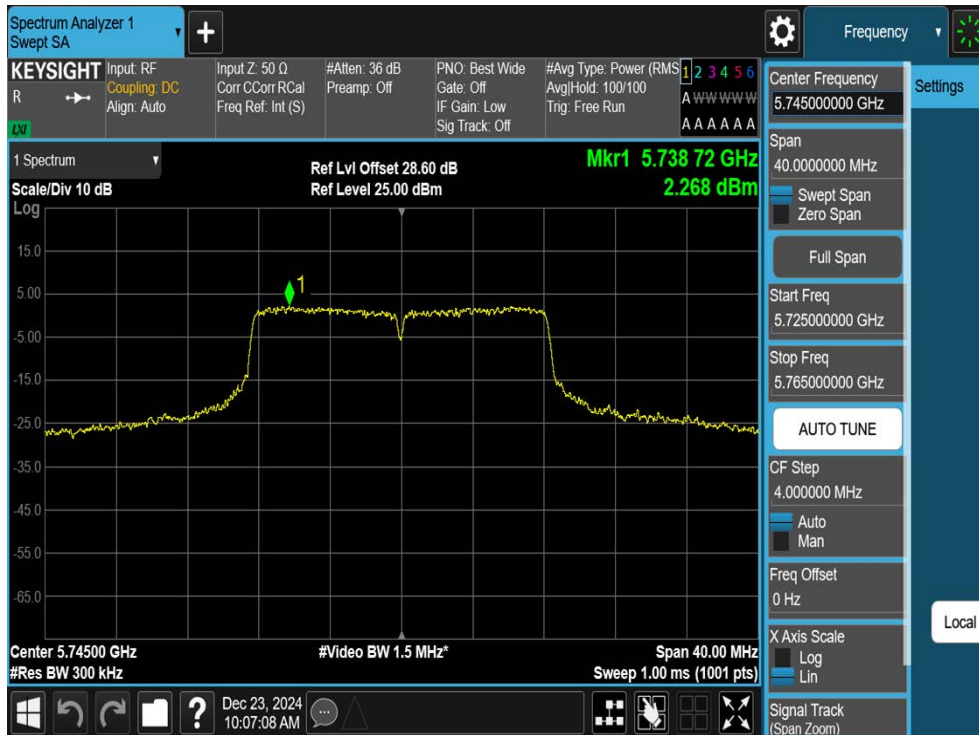

11A-Ant1-5745-PASS

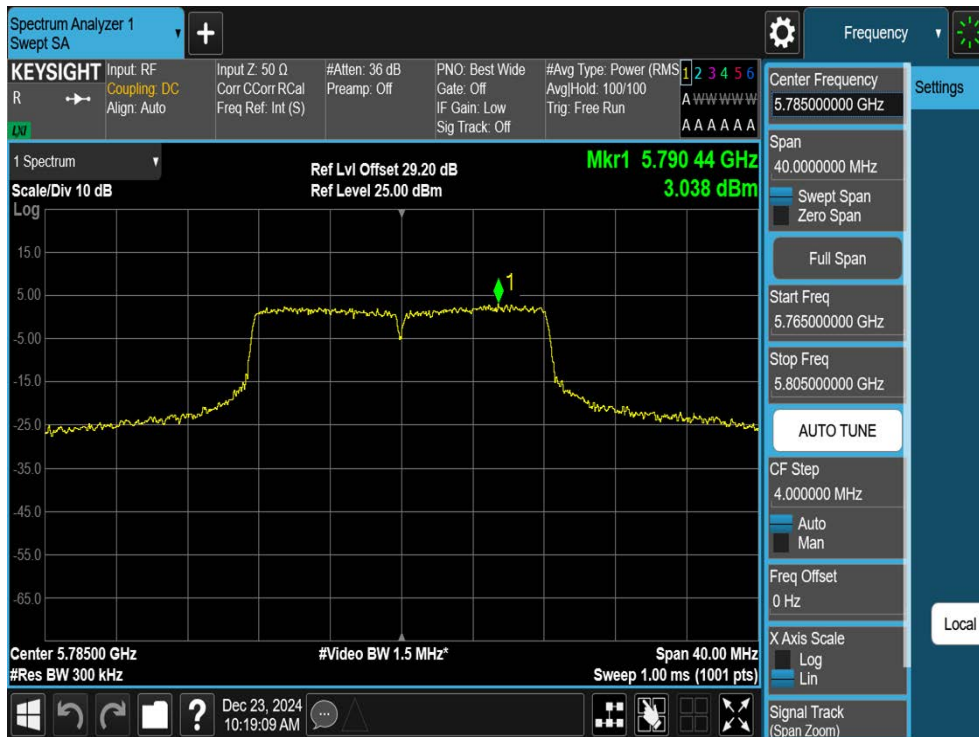

11A-Ant1-5785-PASS

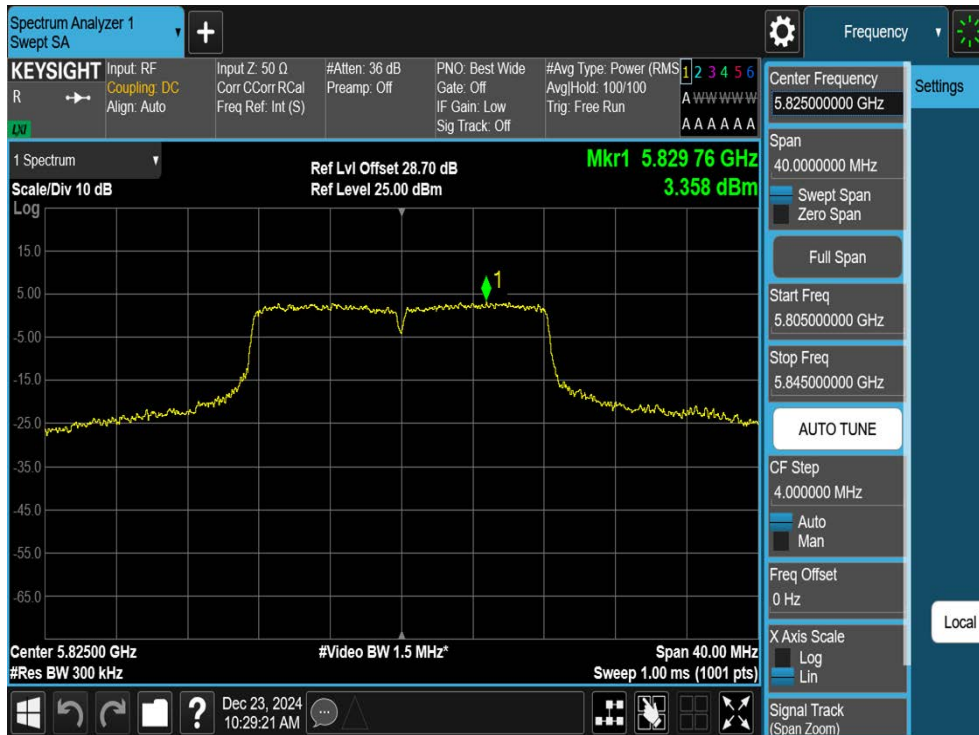

11A-Ant1-5825-PASS

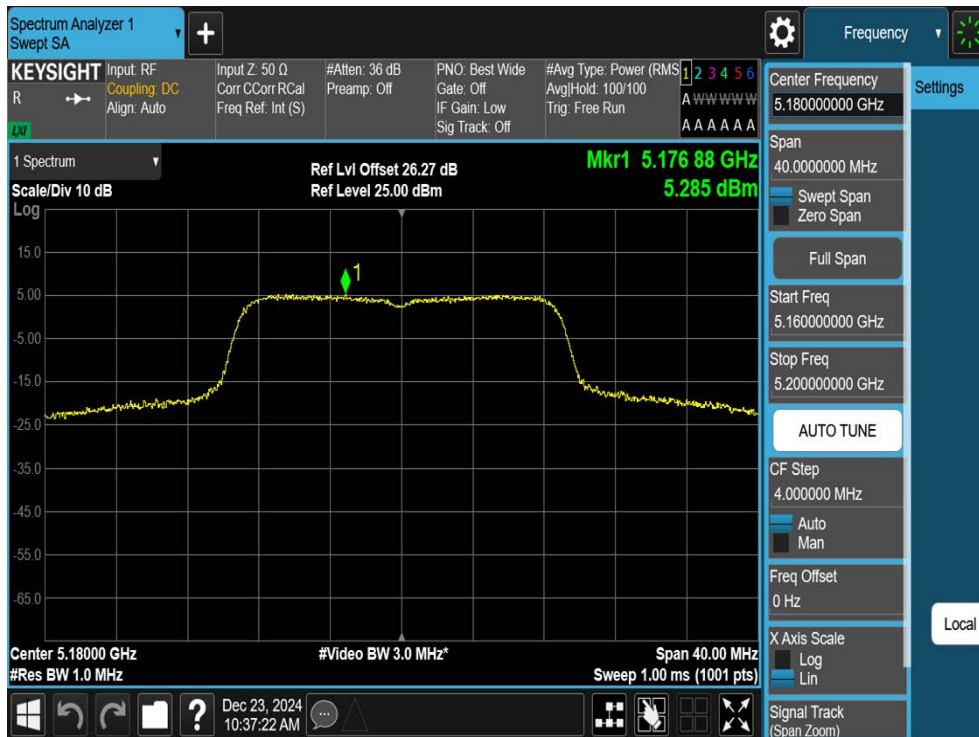

11N20SISO-Ant1-5180-PASS



11N20SISO-Ant1-5200-PASS

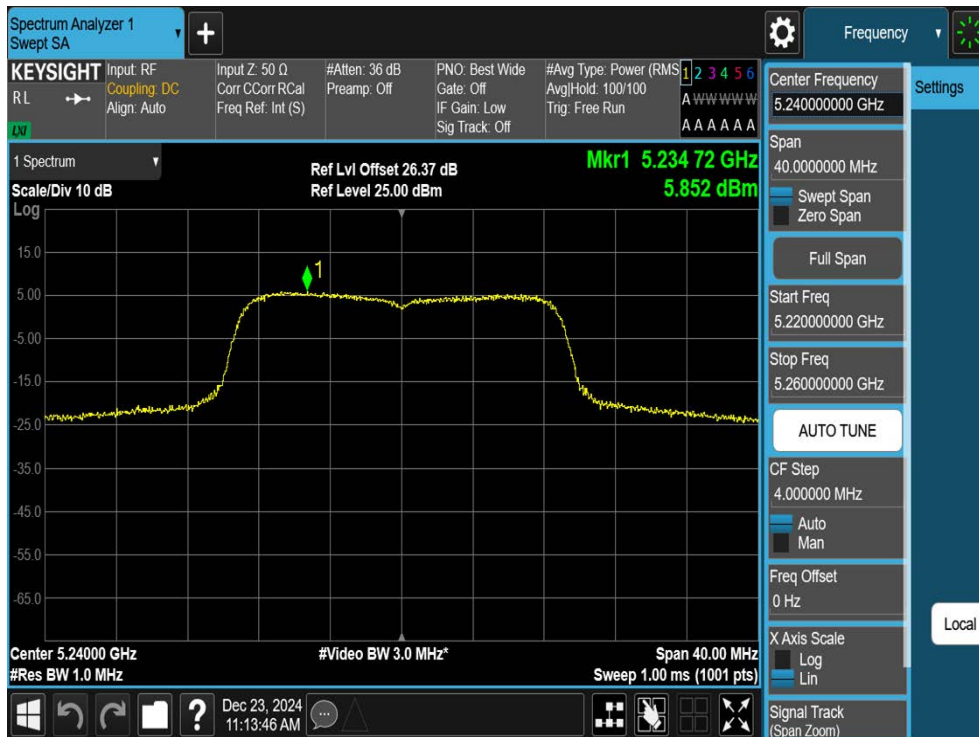

11N20SISO-Ant1-5240-PASS



11N20SISO-Ant1-5260-PASS



11N20SISO-Ant1-5280-PASS

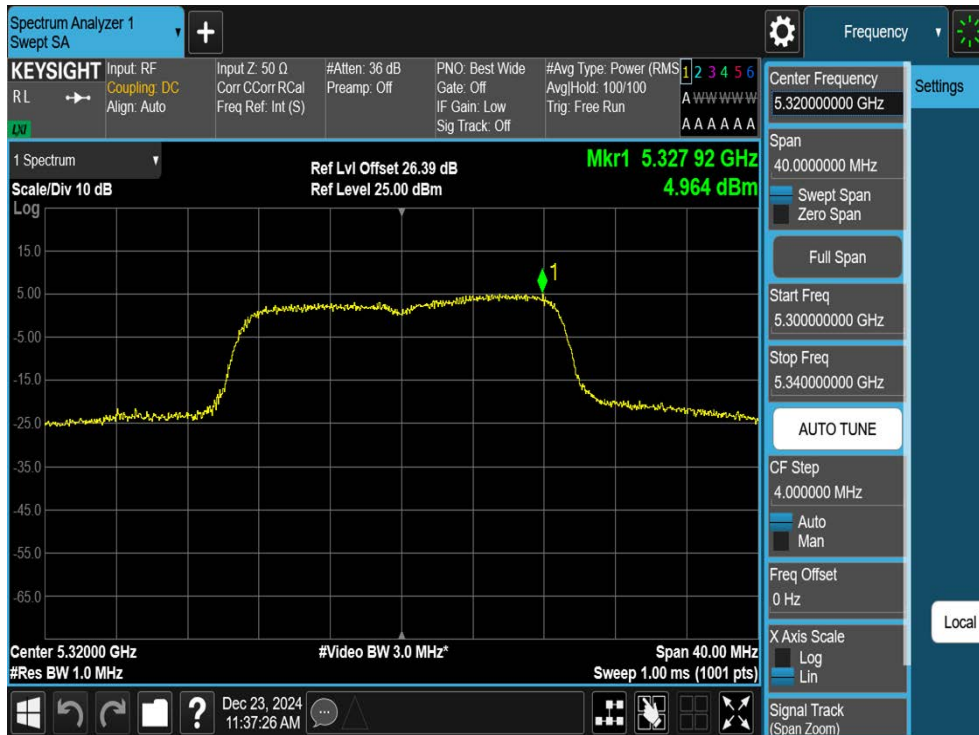

11N20SISO-Ant1-5320-PASS

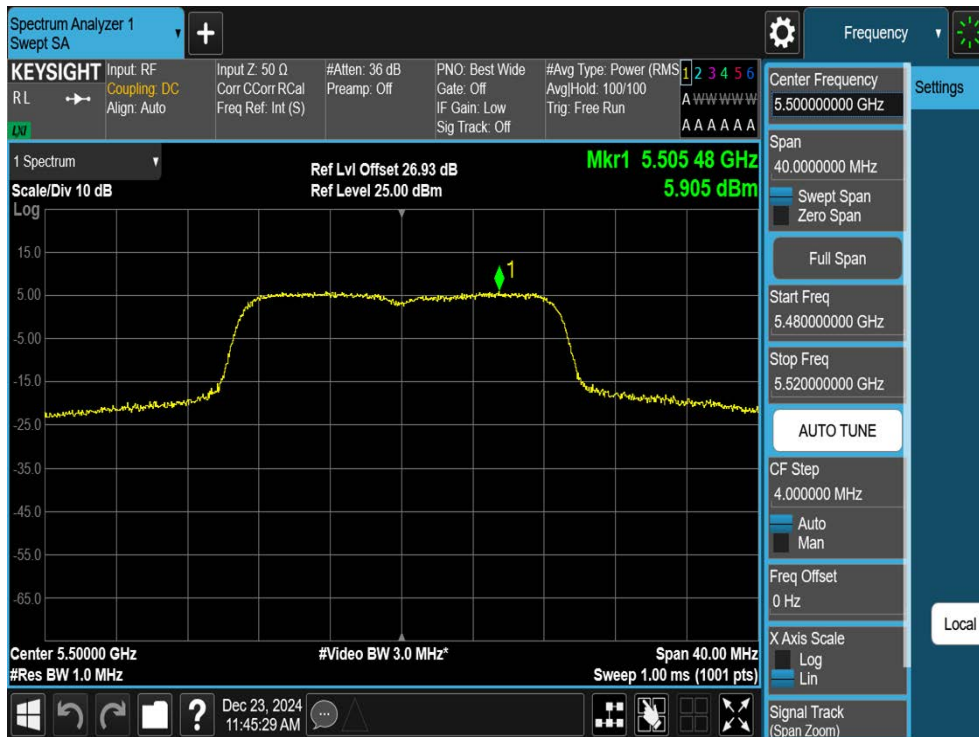

11N20SISO-Ant1-5500-PASS



11N20SISO-Ant1-5580-PASS



11N20SISO-Ant1-5700-PASS

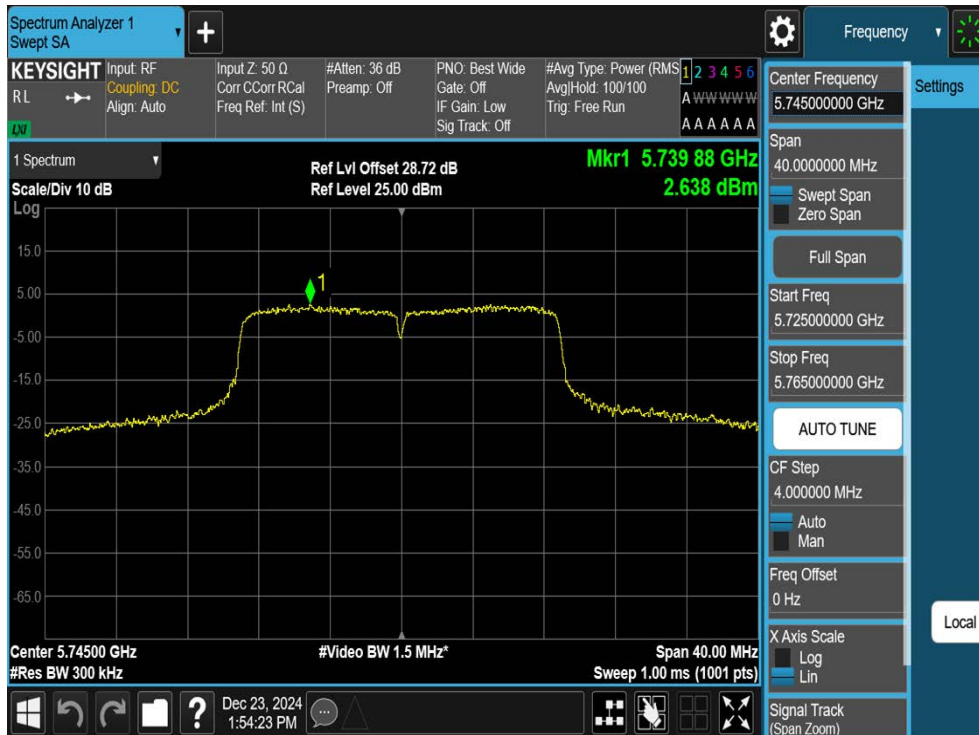

11N20SISO-Ant1-5745-PASS



11N20SISO-Ant1-5785-PASS

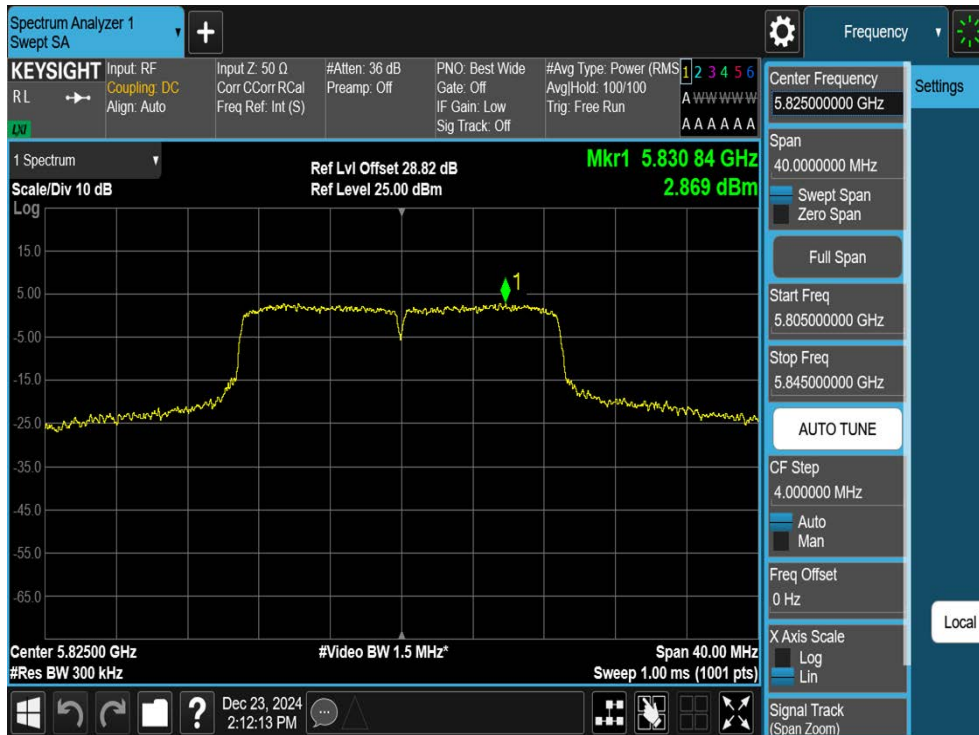

11N20SISO-Ant1-5825-PASS

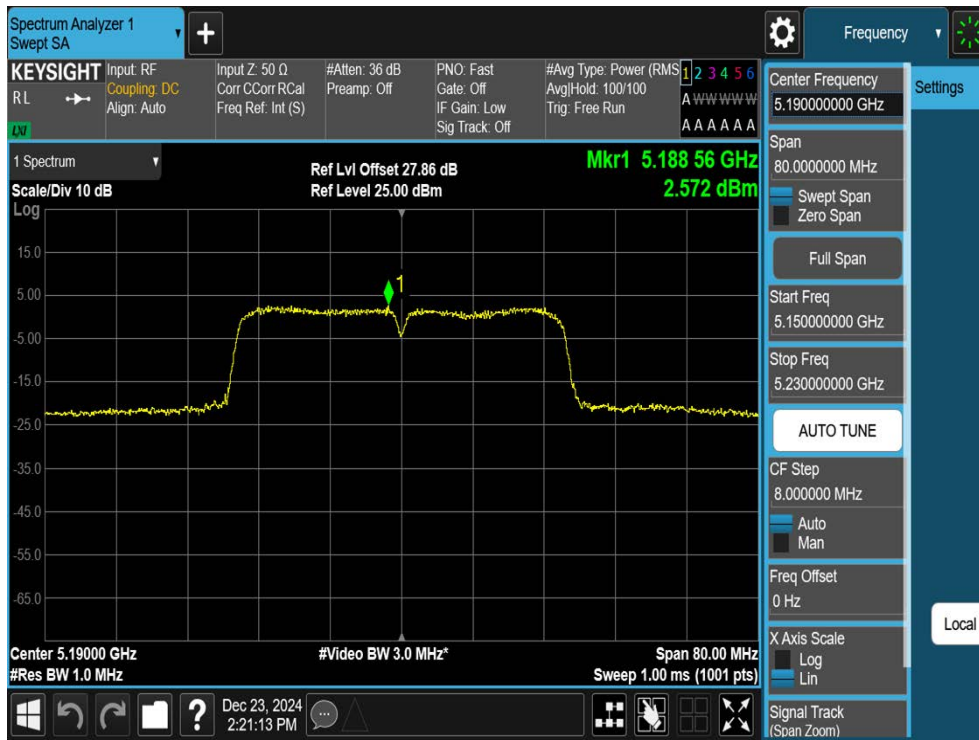

11N40SISO-Ant1-5190-PASS

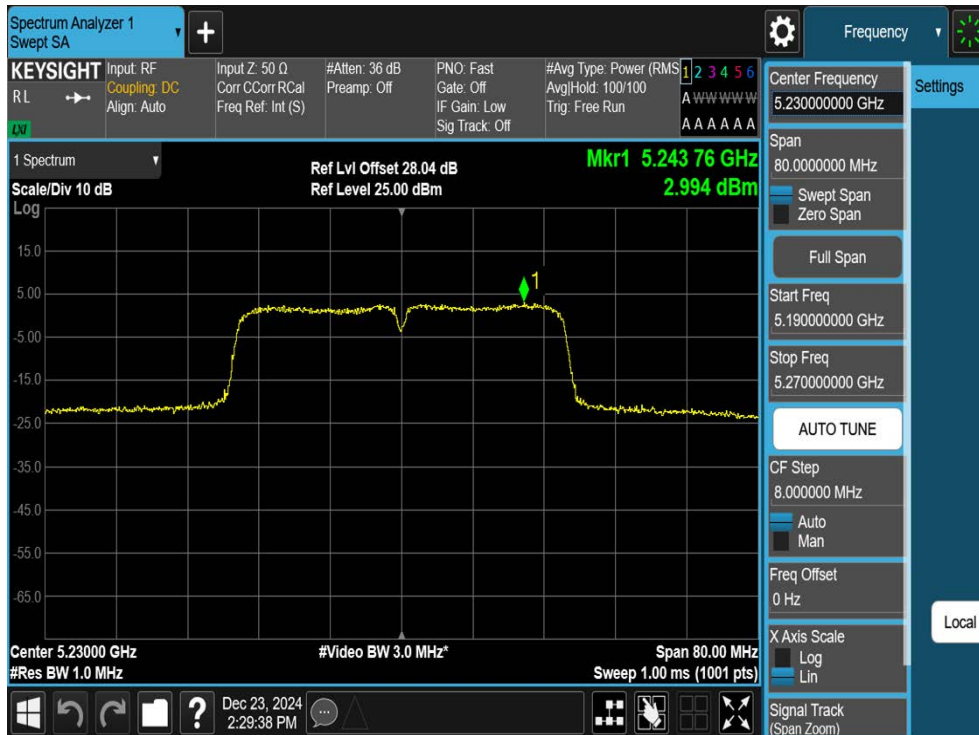

11N40SISO-Ant1-5230-PASS

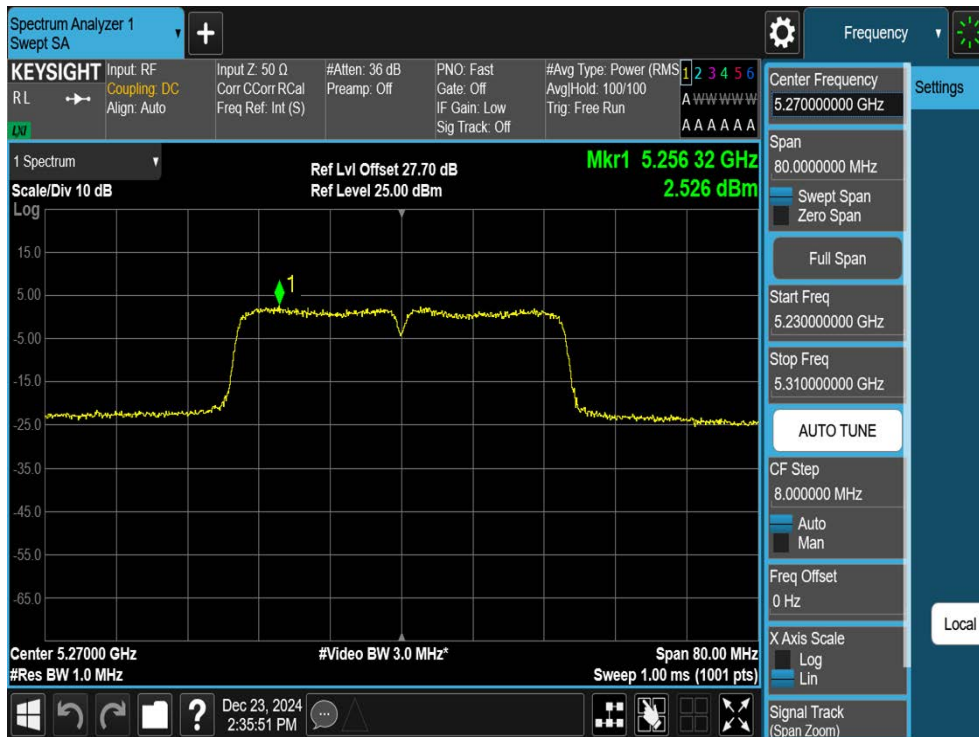

11N40SISO-Ant1-5270-PASS

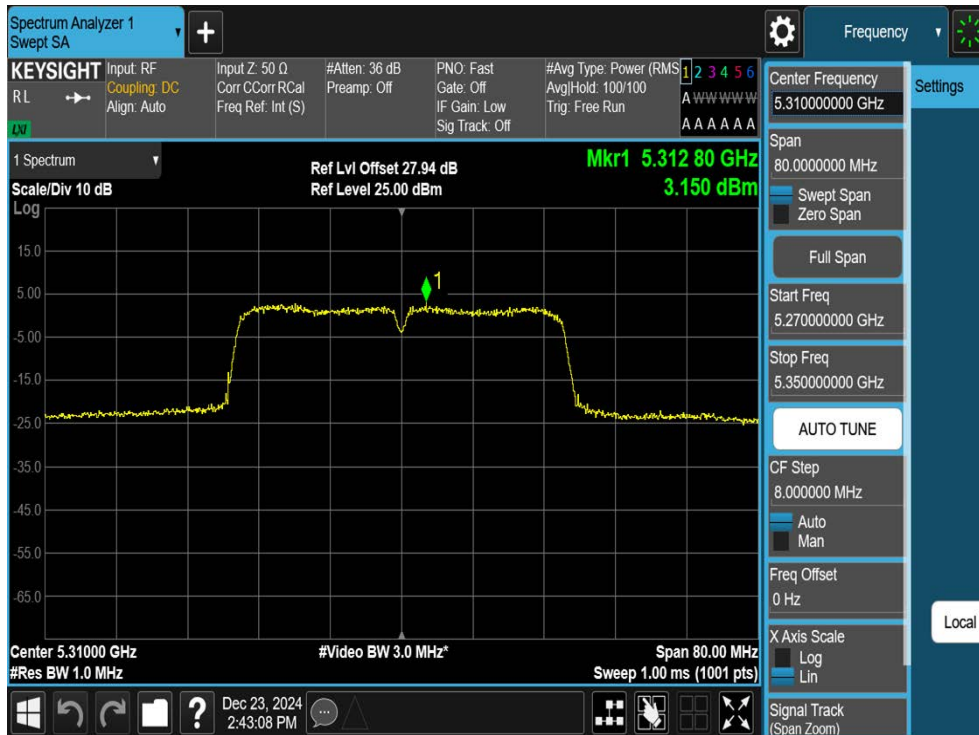

11N40SISO-Ant1-5310-PASS

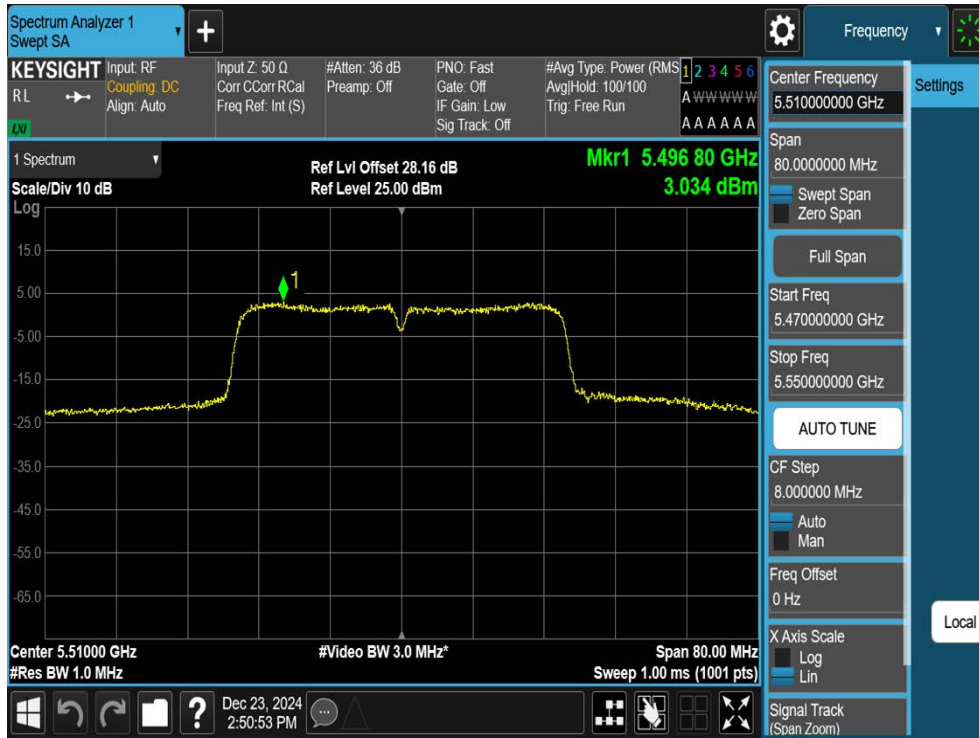

11N40SISO-Ant1-5510-PASS

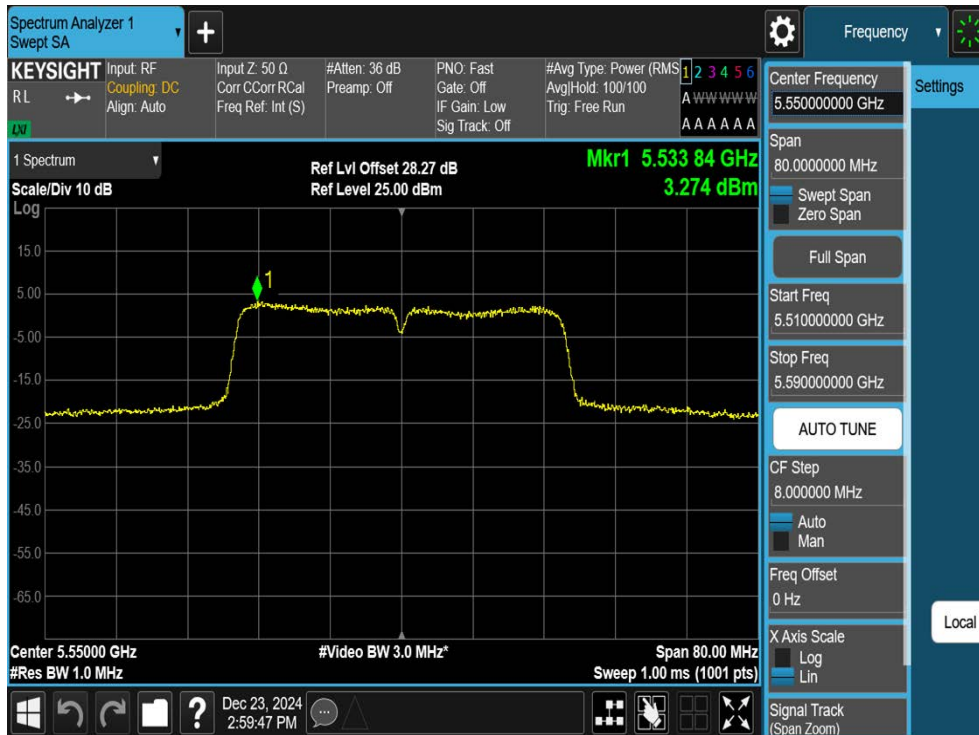

11N40SISO-Ant1-5550-PASS

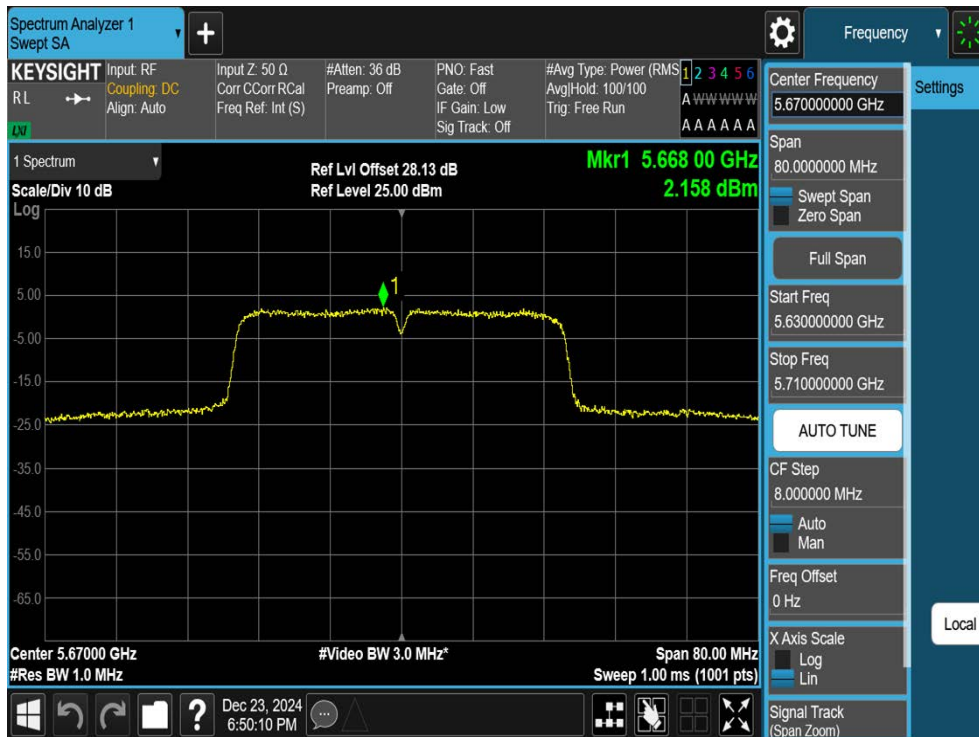

11N40SISO-Ant1-5670-PASS

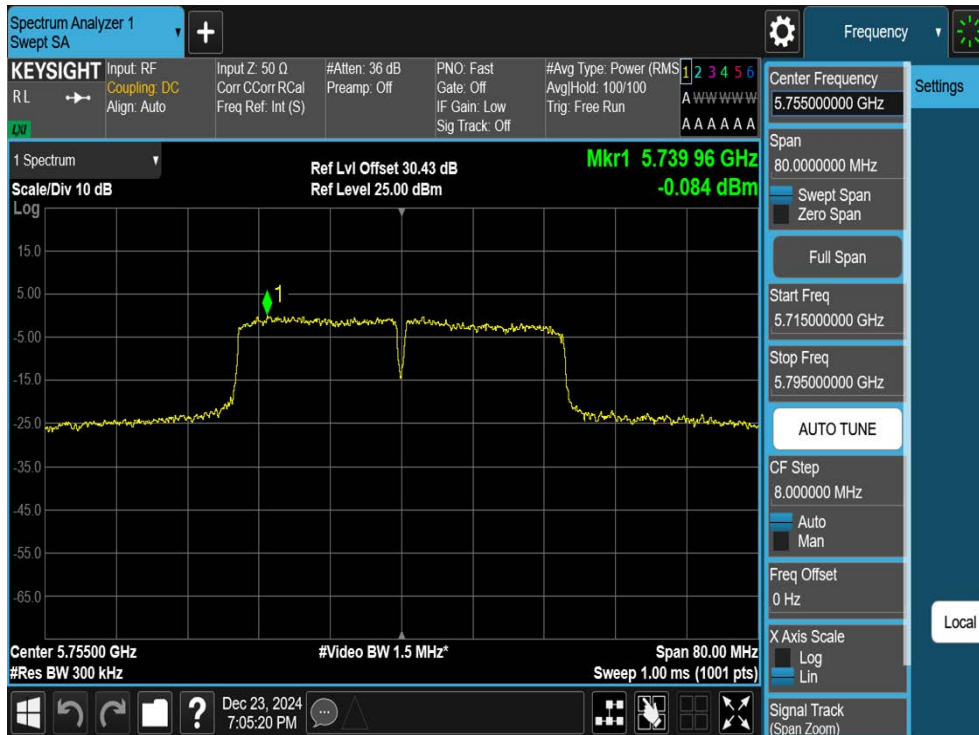

11N40SISO-Ant1-5755-PASS

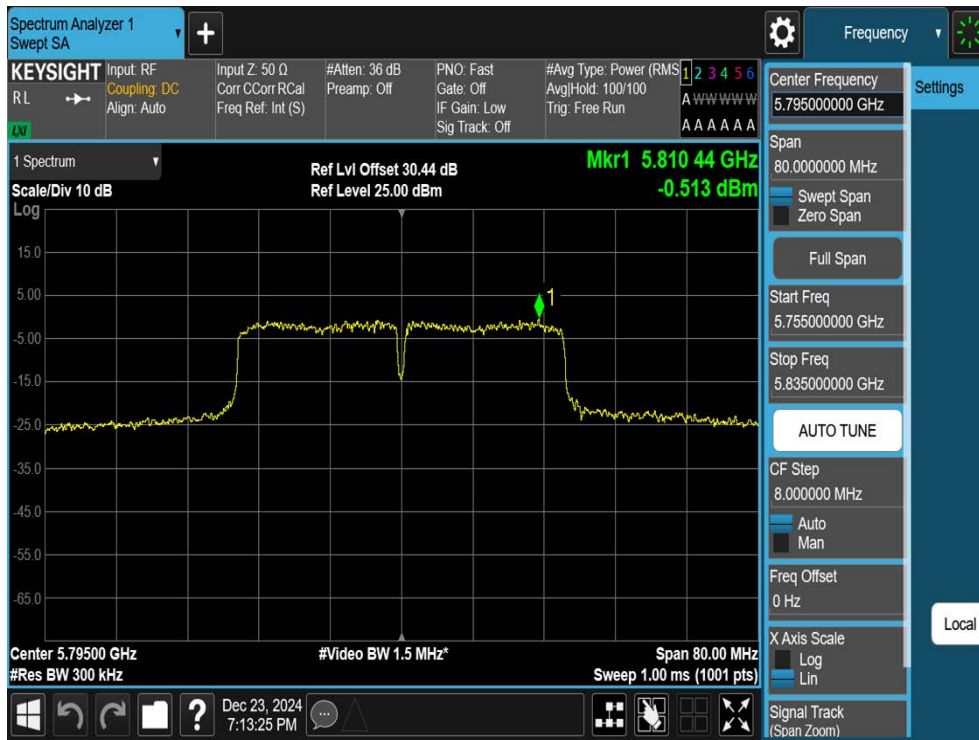

11N40SISO-Ant1-5795-PASS

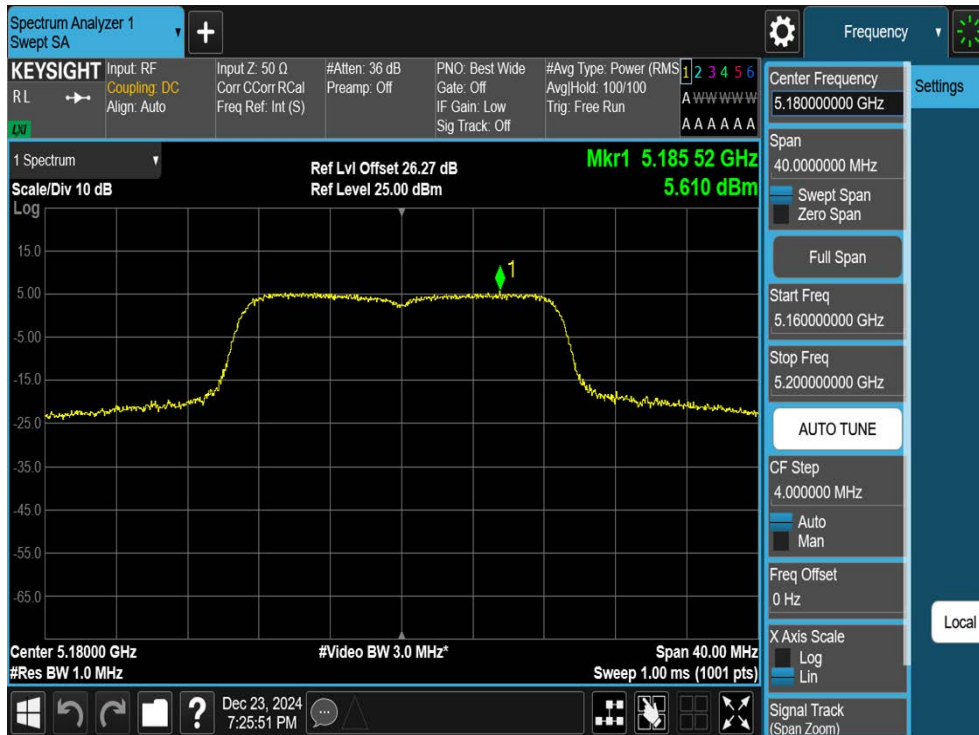

11A20SISO-Ant1-5180-PASS

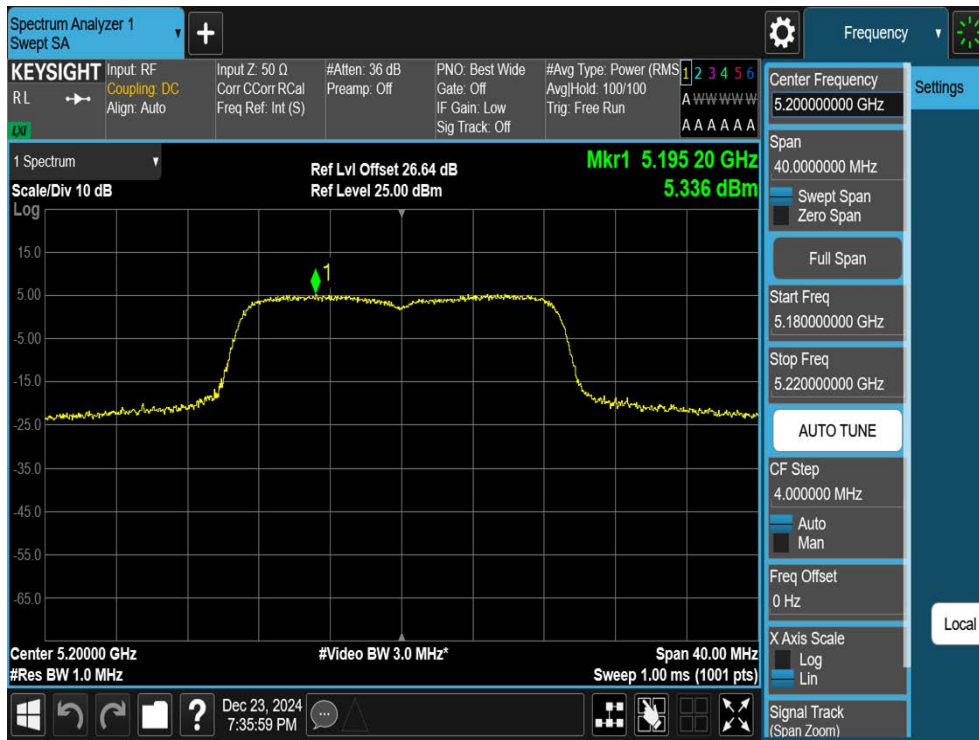

11AC20SISO-Ant1-5200-PASS

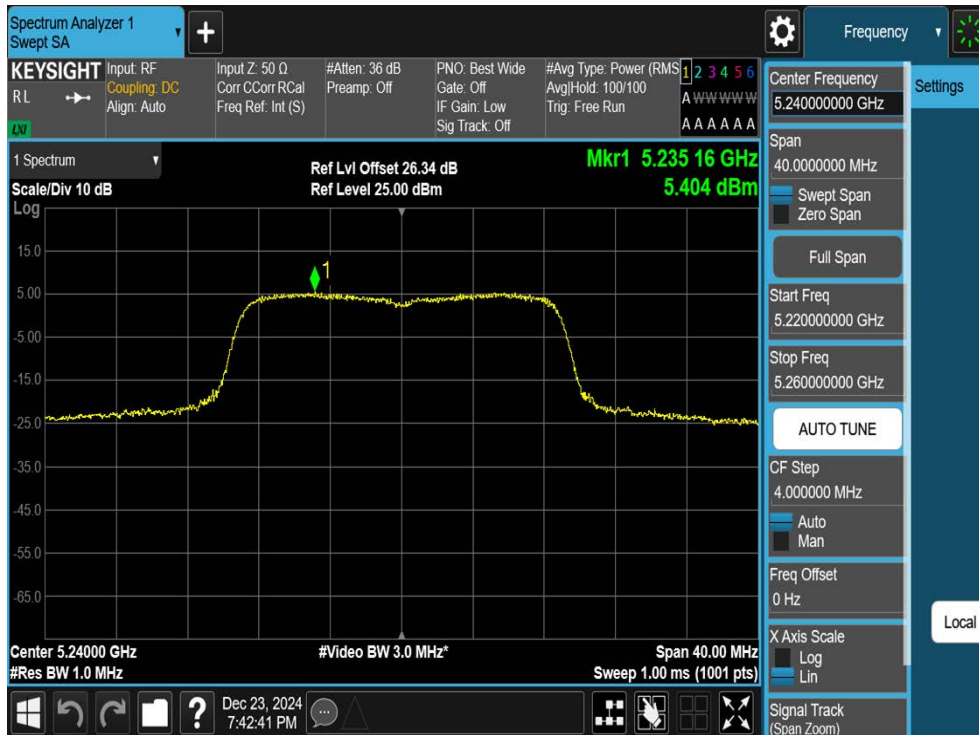

11AC20SISO-Ant1-5240-PASS

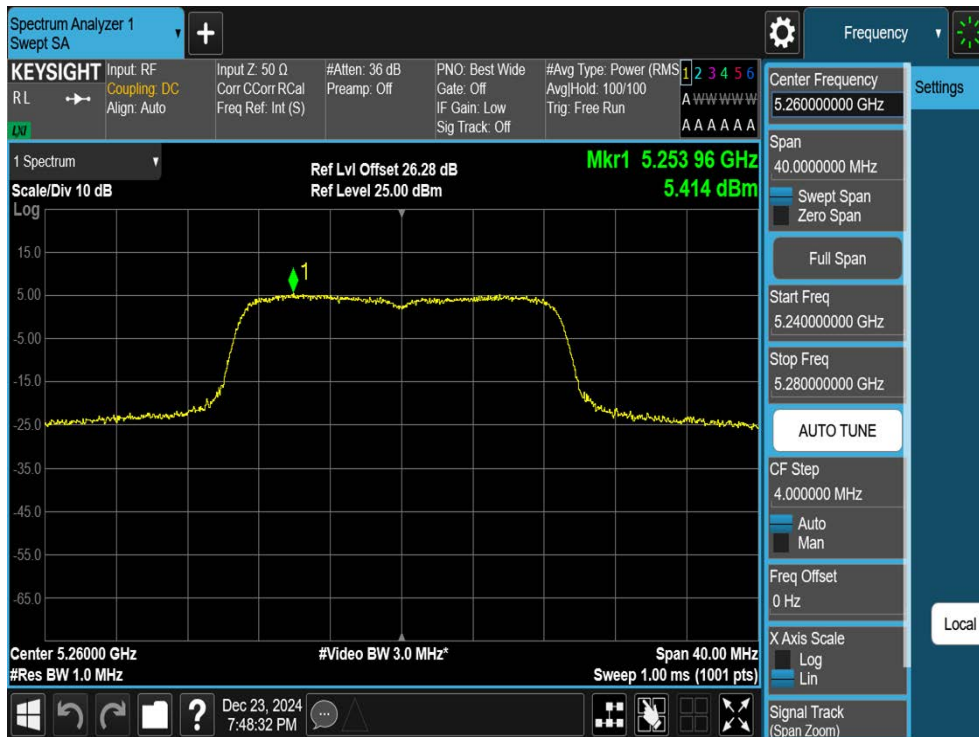

11AC20SISO-Ant1-5260-PASS



11AC20SISO-Ant1-5280-PASS

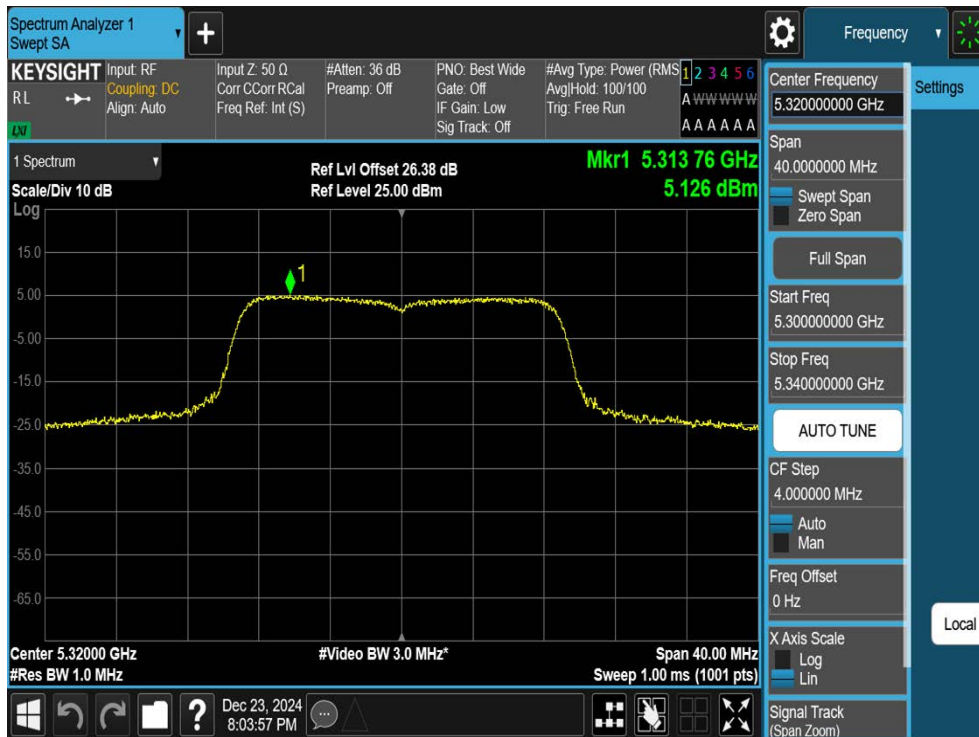

11AC20SISO-Ant1-5320-PASS

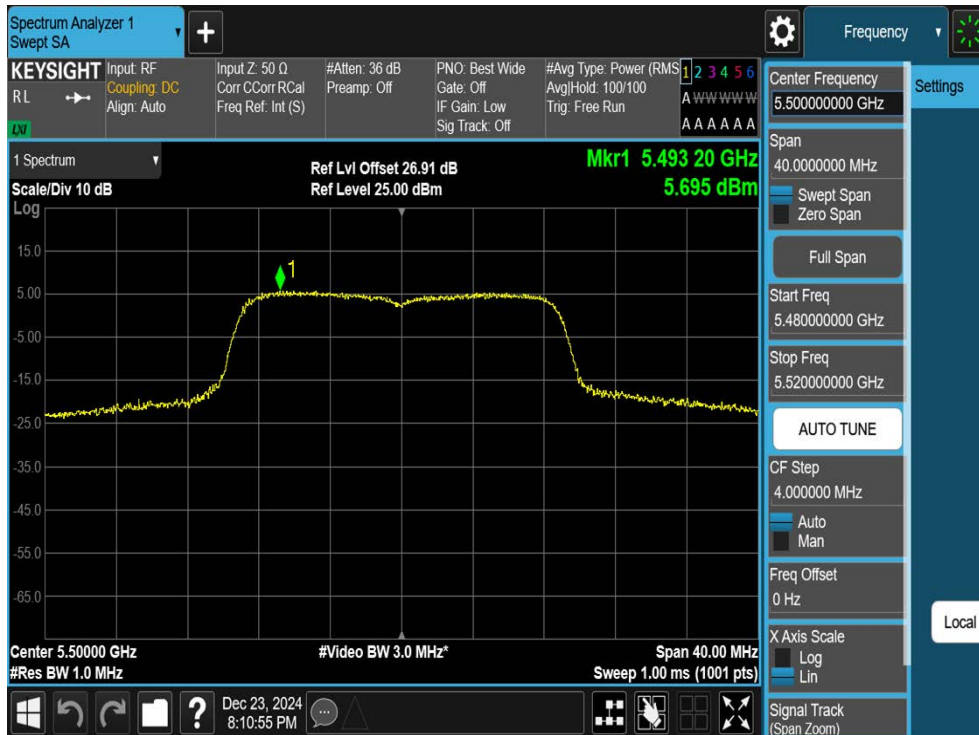

11AC20SISO-Ant1-5500-PASS

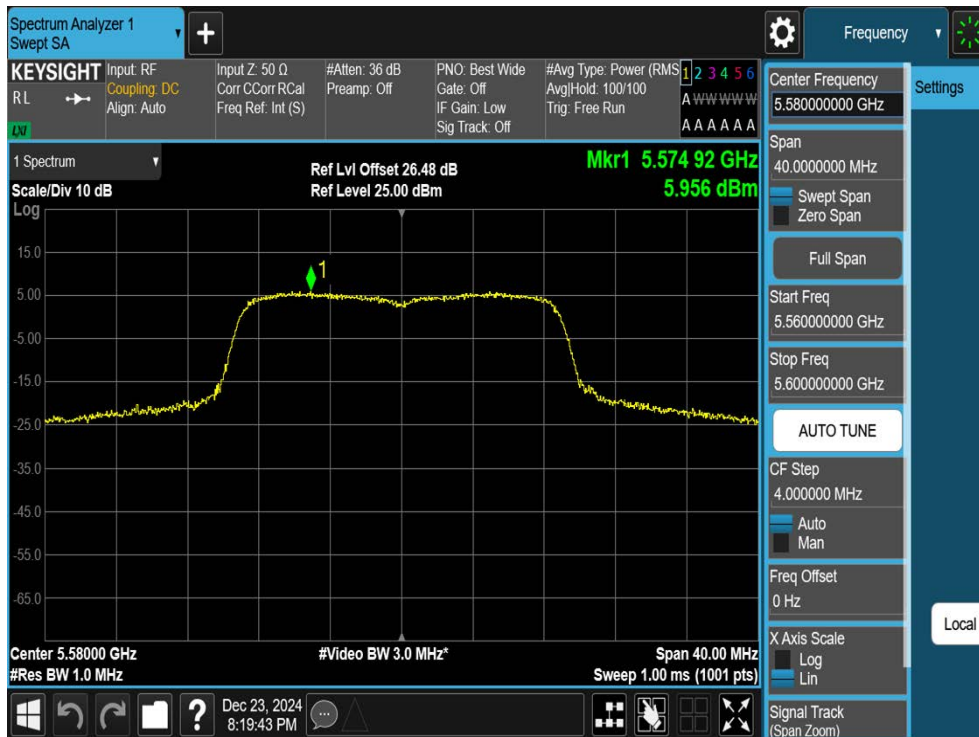

11AC20SISO-Ant1-5580-PASS



11AC20SISO-Ant1-5700-PASS



11AC20SISO-Ant1-5745-PASS

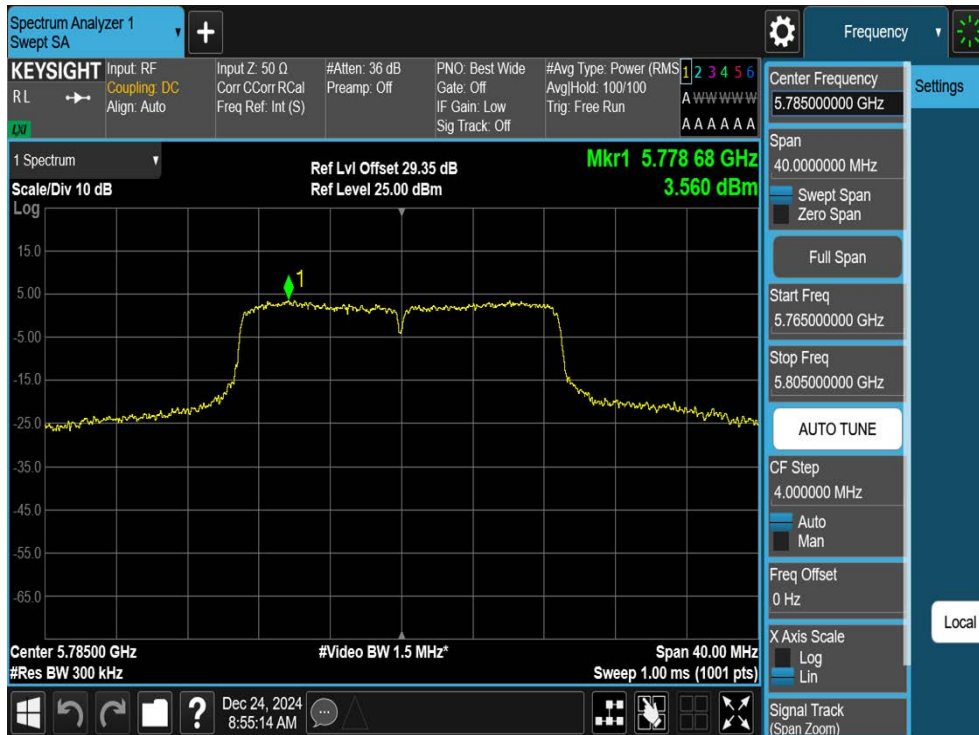

11AC20SISO-Ant1-5785-PASS

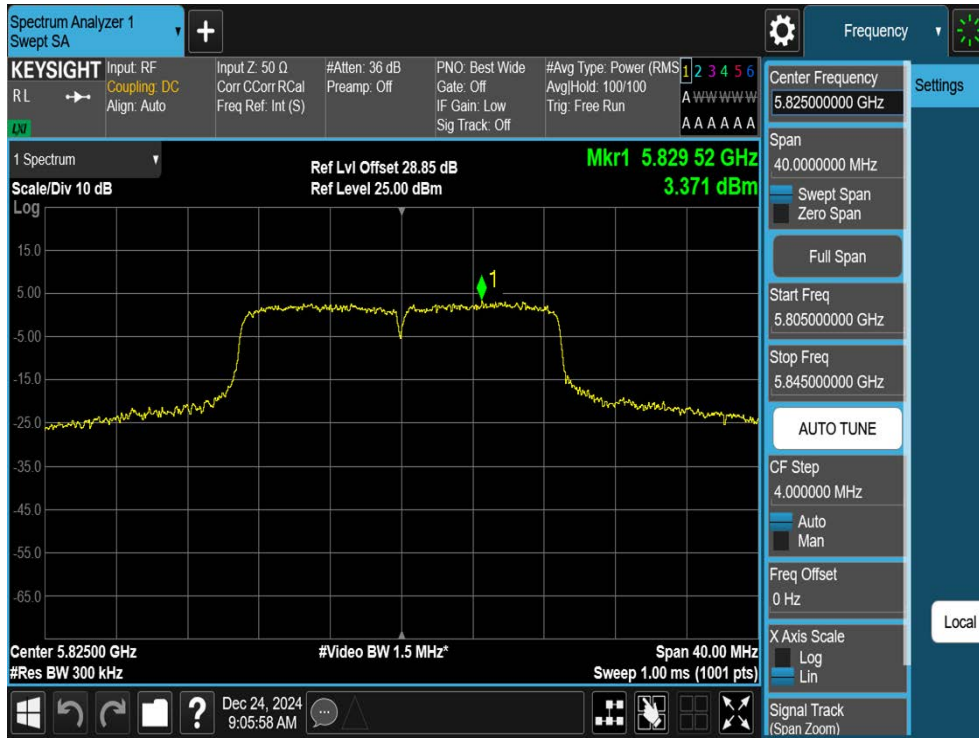

11AC20SISO-Ant1-5825-PASS

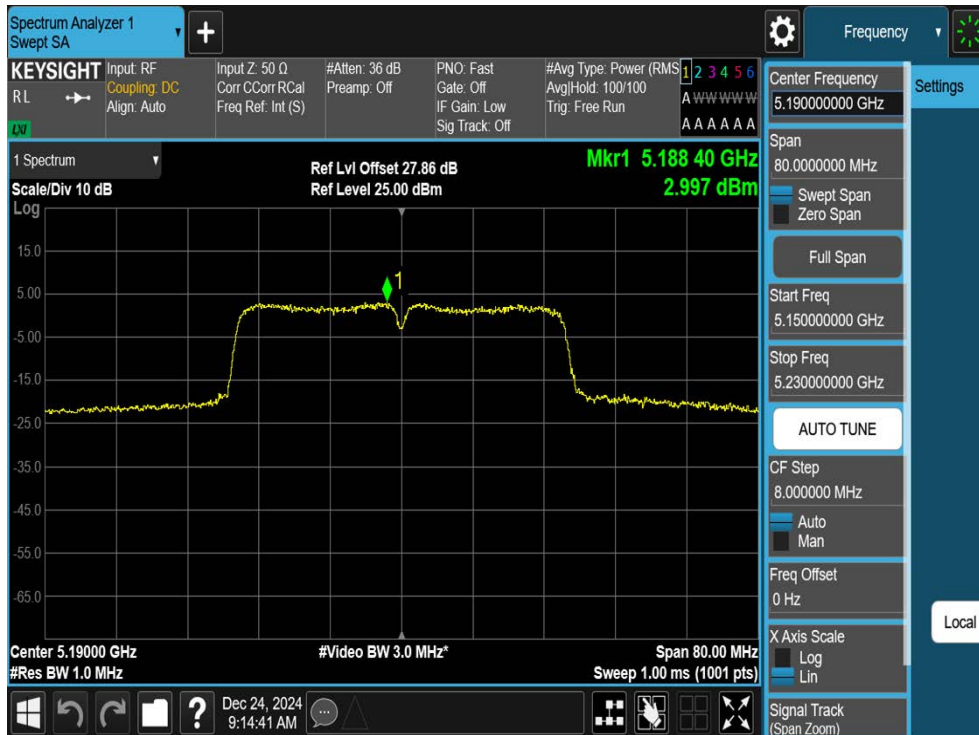

11AC40SISO-Ant1-5190-PASS

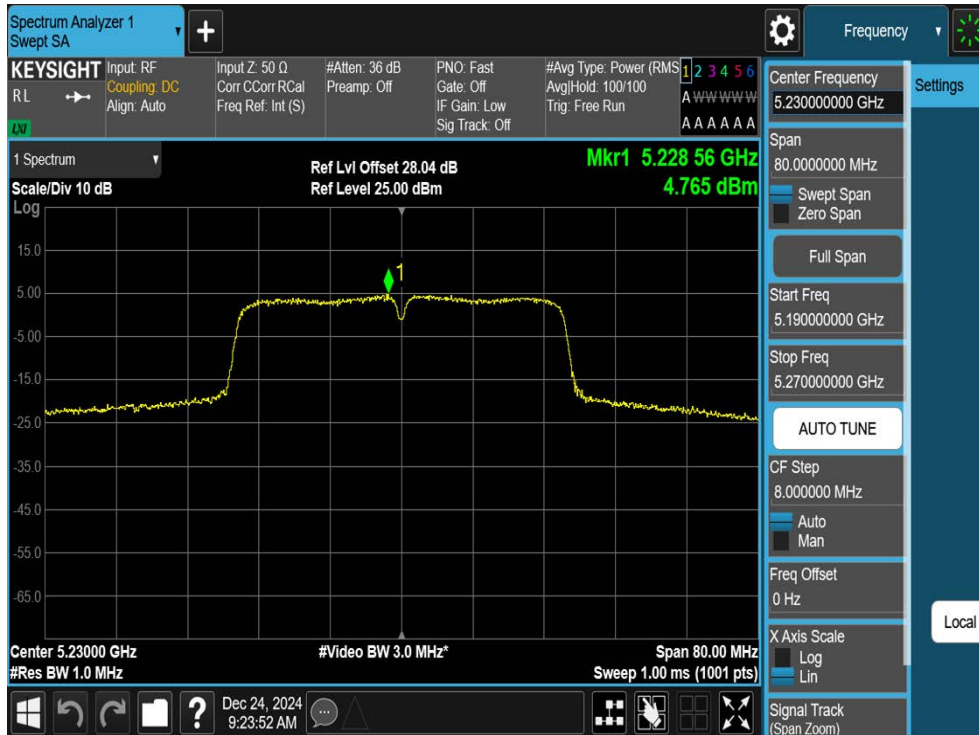

11AC40SISO-Ant1-5230-PASS

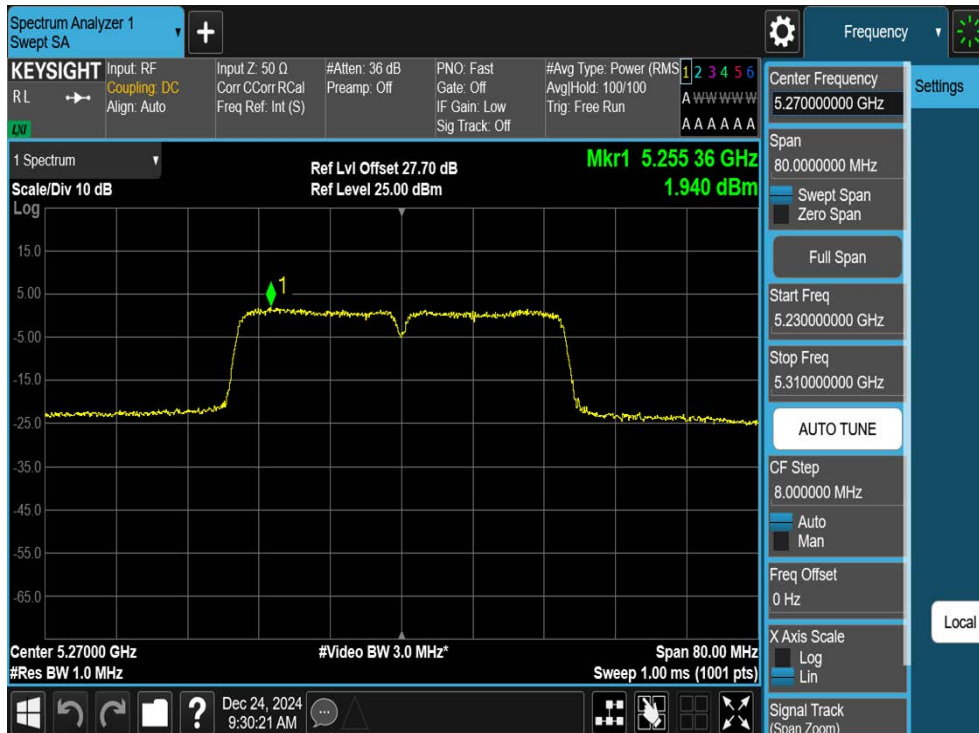

11AC40SISO-Ant1-5270-PASS



11AC40SISO-Ant1-5310-PASS

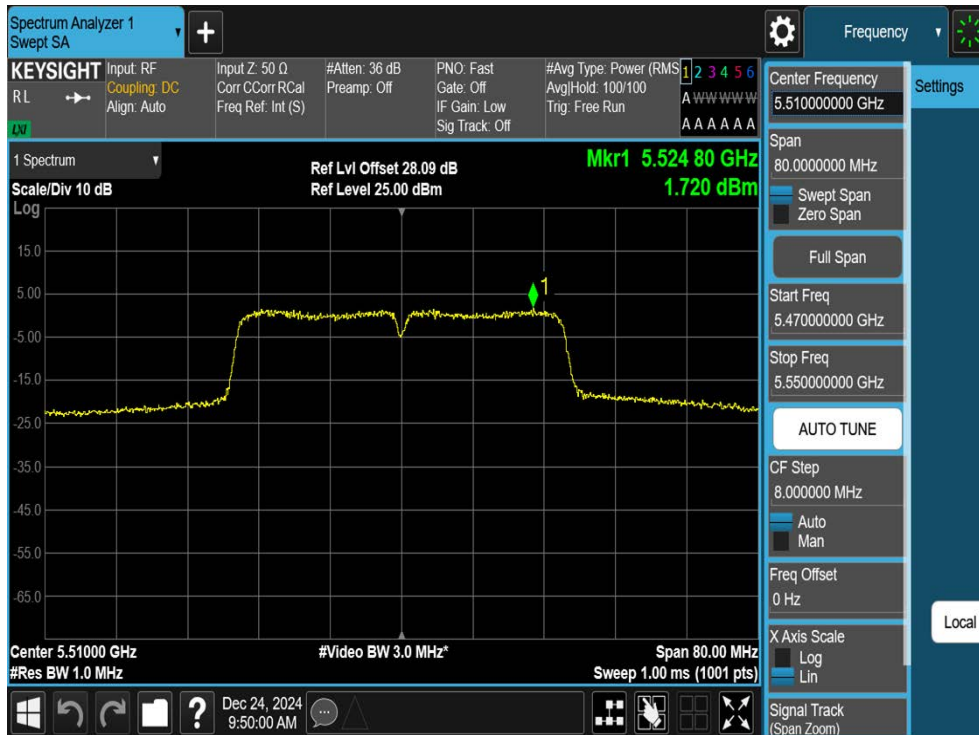

11AC40SISO-Ant1-5510-PASS

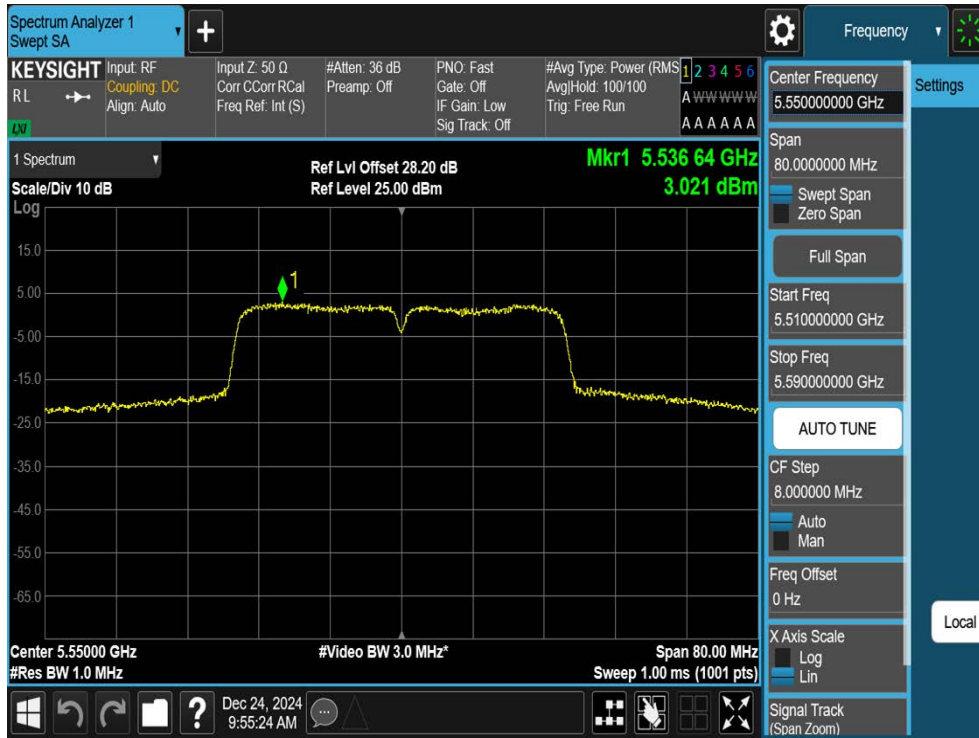

11AC40SISO-Ant1-5550-PASS

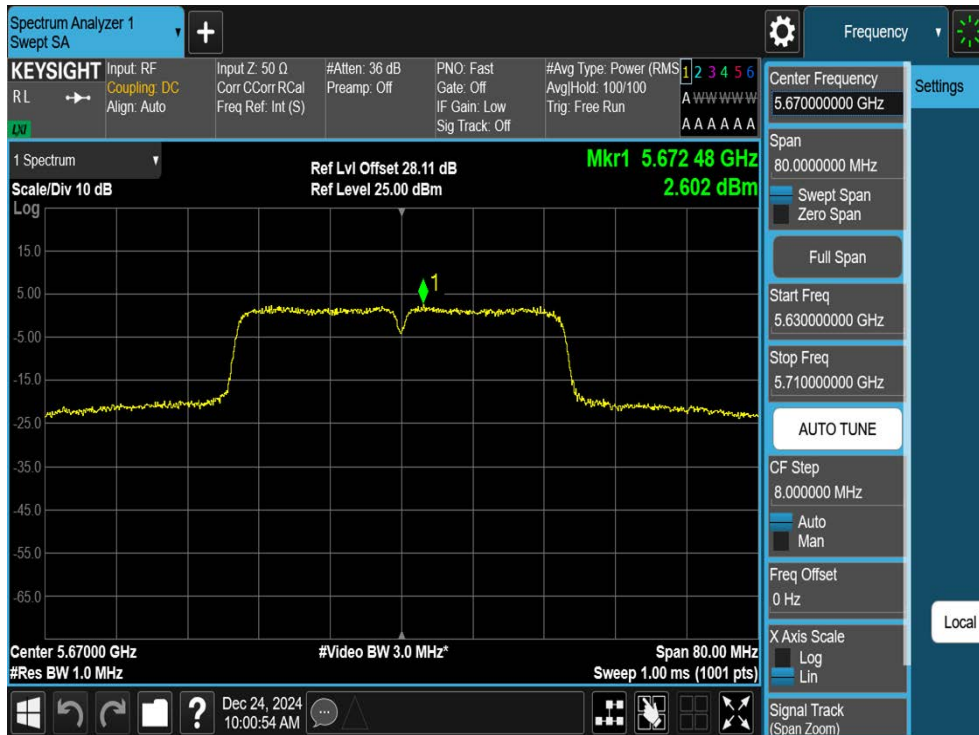

11AC40SISO-Ant1-5670-PASS

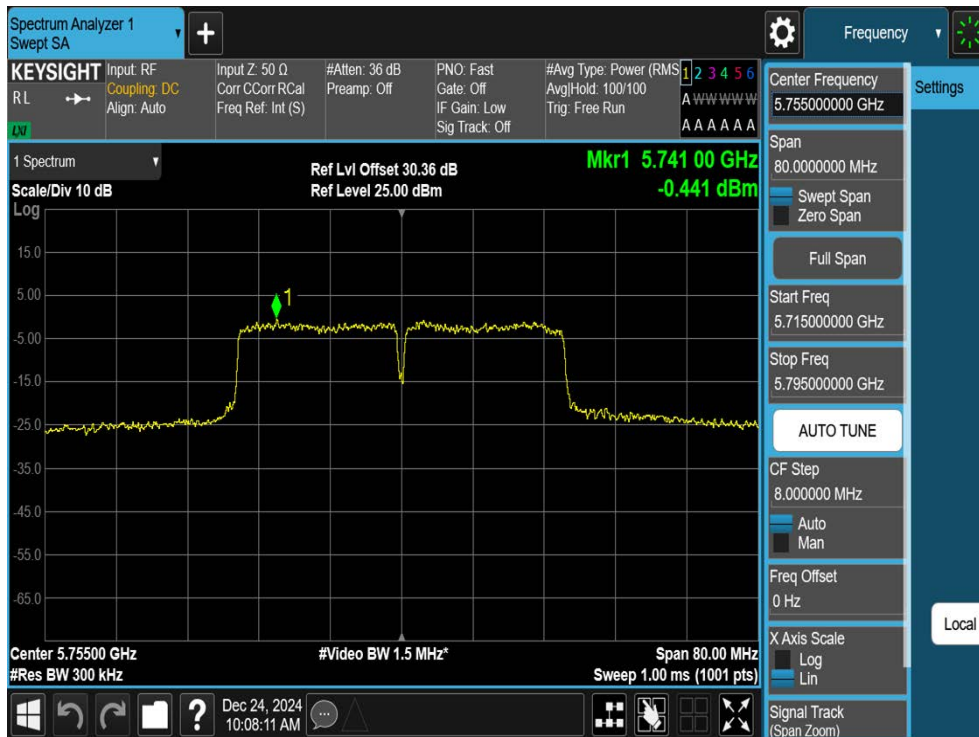

11AC40SISO-Ant1-5755-PASS

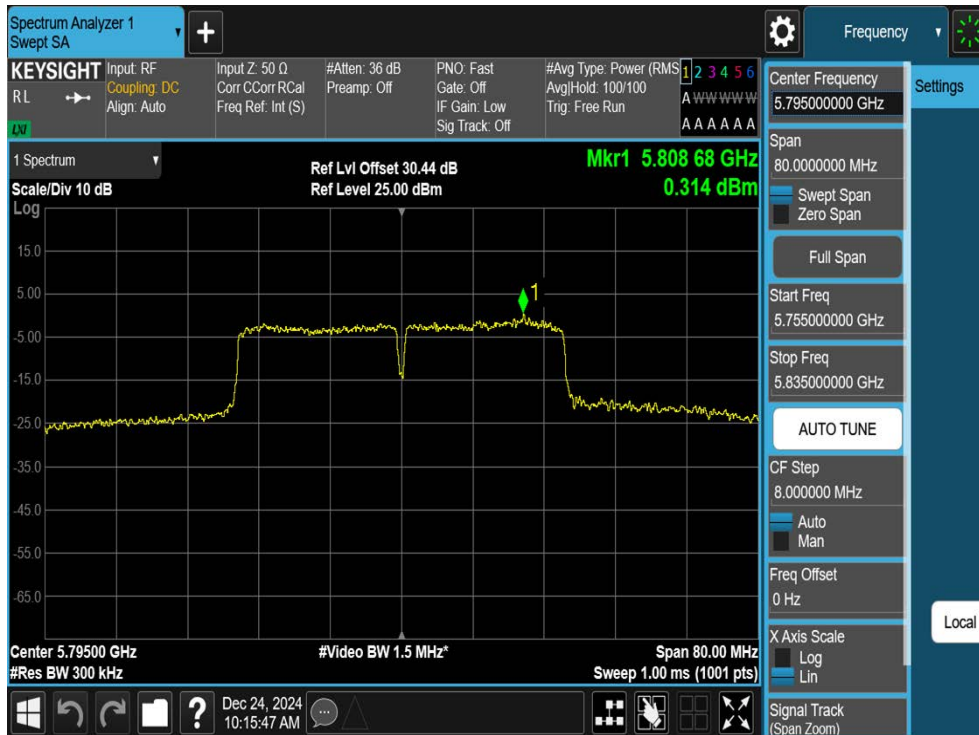

11AC40SISO-Ant1-5795-PASS

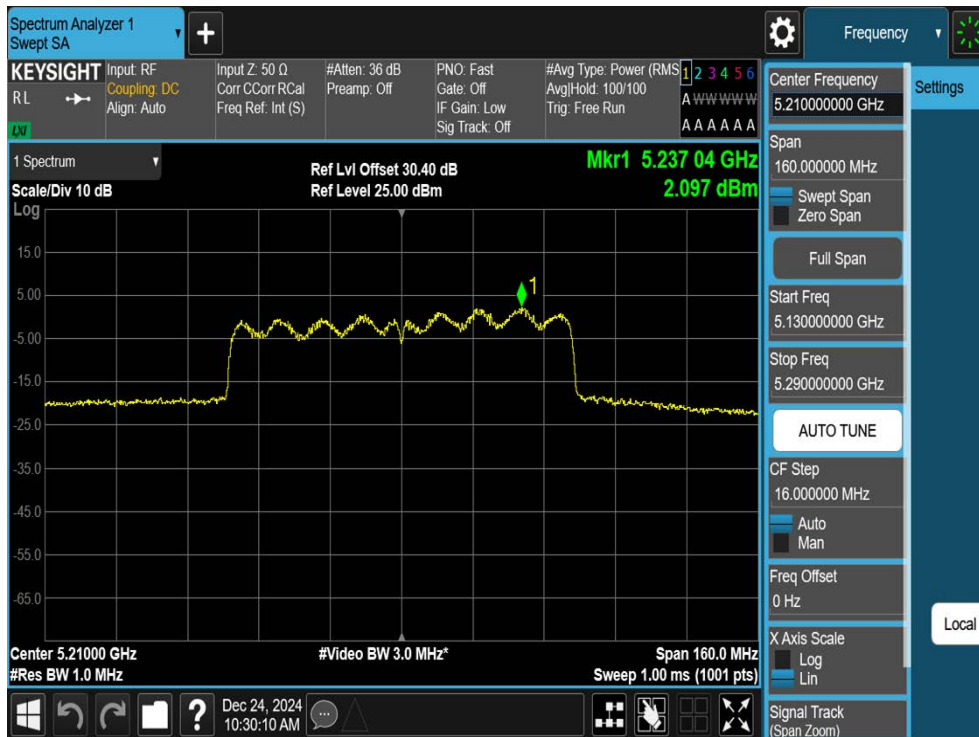

11AC80SISO-Ant1-5210-PASS

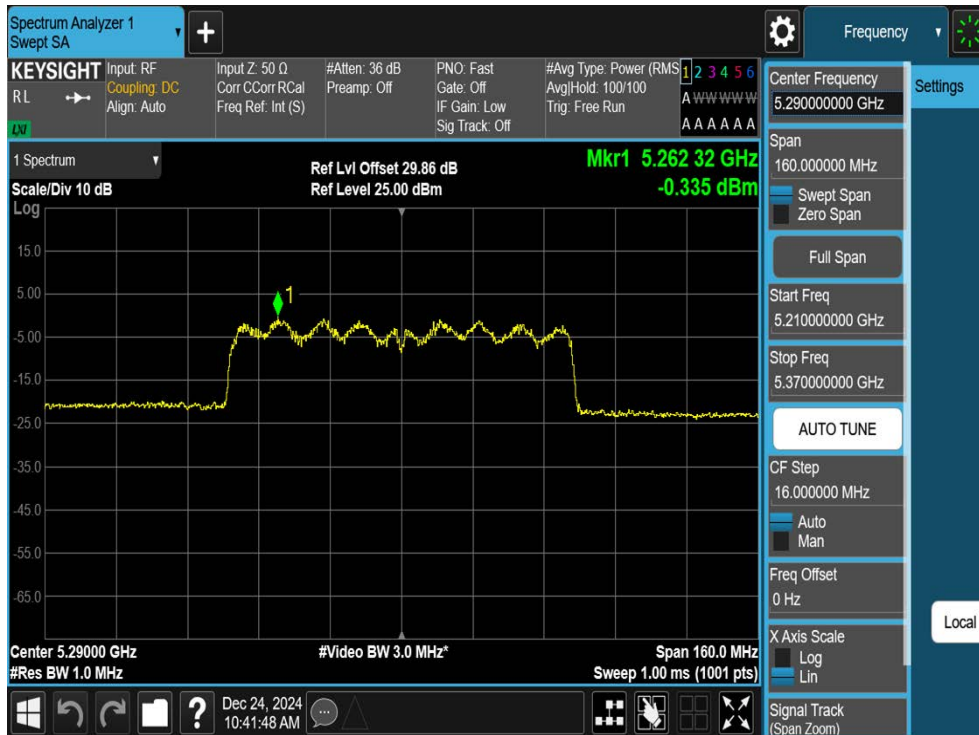

11AC80SISO-Ant1-5290-PASS

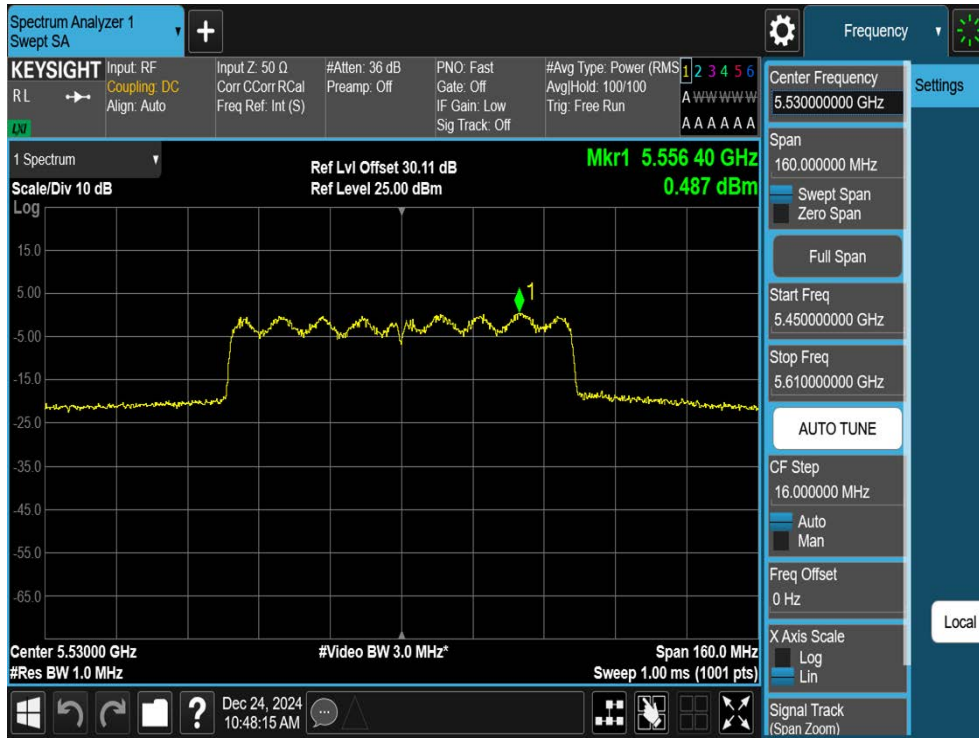

11AC80SISO-Ant1-5530-PASS

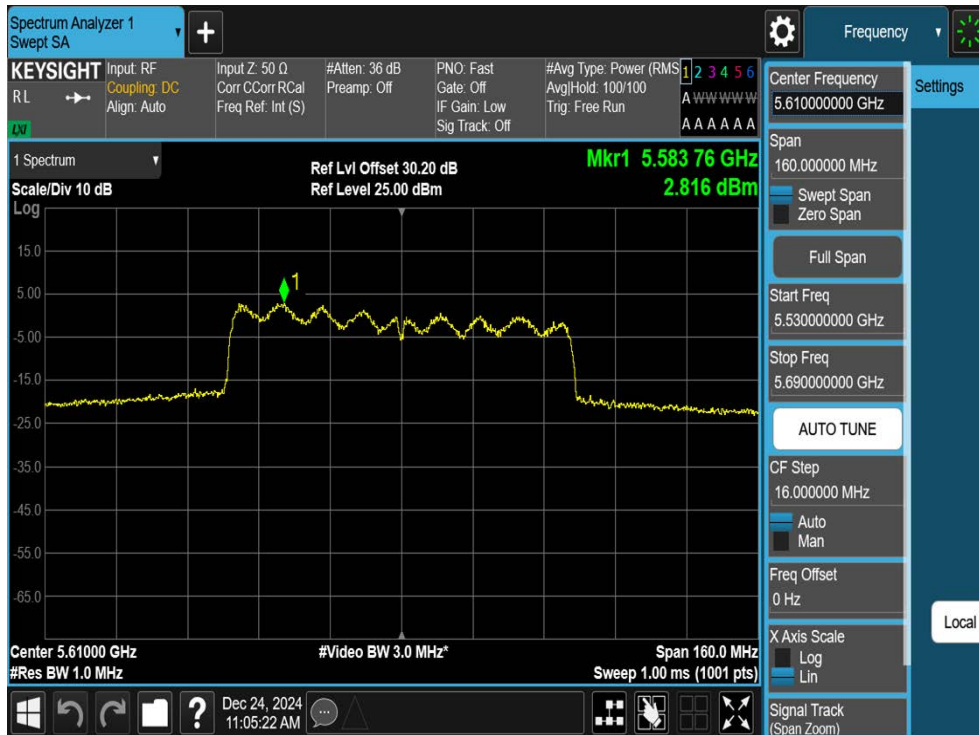

11AC80SISO-Ant1-5610-PASS

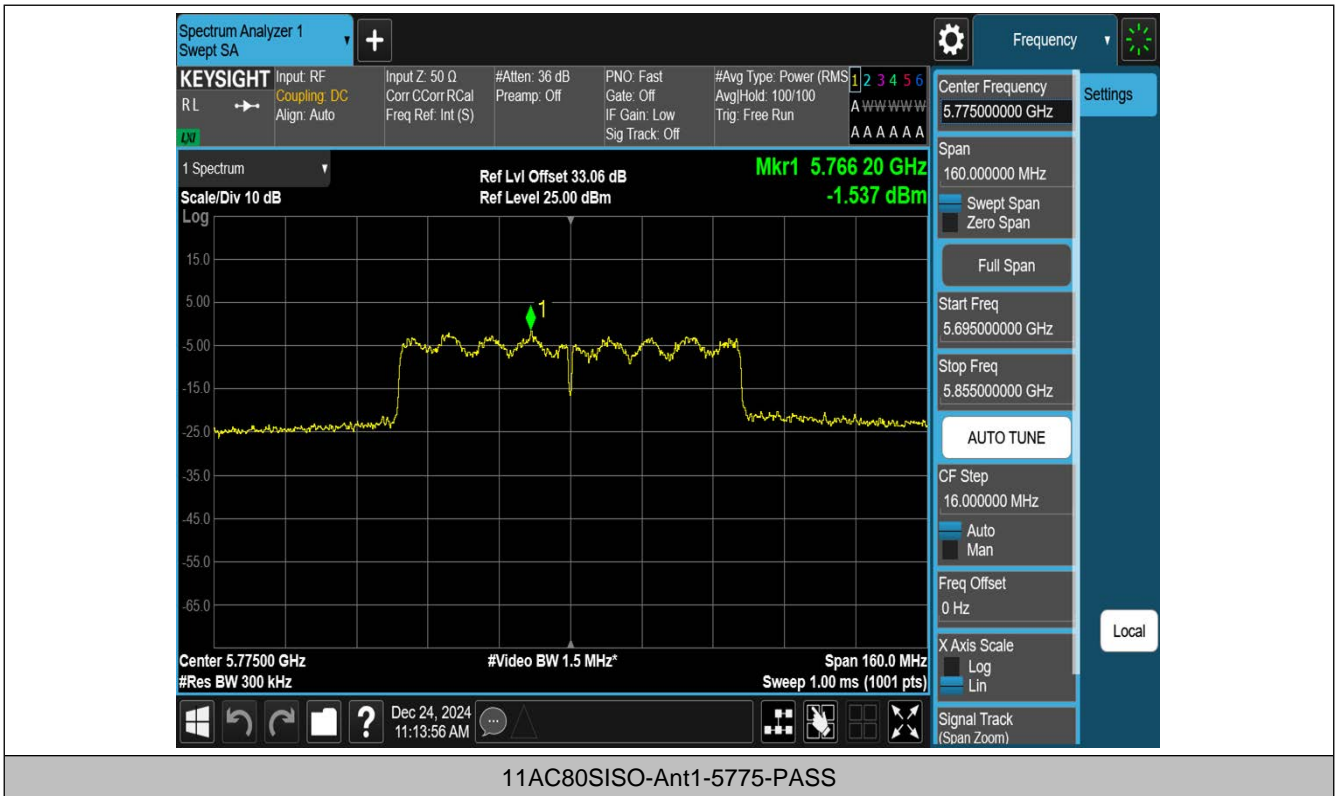

Statement

1. The report is invalid without the official seal or special seal of Shenzhen Haiyun Standard Technology Co., Ltd. (hereinafter referred to as the unit).
2. The report is invalid without the signature of the approver.
3. The report is invalid if altered arbitrarily.
4. The report shall not be partially copied without the written approval of the unit.
5. The reported test results are only valid for the tested samples.
6. If there is any objection to the test report, it shall be submitted to the test unit within 15 days from the date of receiving the report, and the overdue shall not be accepted.

Shenzhen Haiyun Standard Technology Co., Ltd.

Address: Room 110, 111, 112, 113, 115, 116, Block B, Jinyuan Business Building, No. 302, Xixiang Avenue, Labor Community, Xixiang Street, Baoan District, Shenzhen, China

Tel: 0755-26024411

Email: service@hy-lab.cn

(END OF REPORT)