

KESHARE ELCTRON LTD

SAMPLE SPECIFICATION

(Revision: R: A1)

CUSTOMER		
CS P/N	HQ252-COPPER PIPE ANTENNA	
PART NAME	WIFI ANTENNA	L=252MM
FREQUENCY	2.4G~2.5G/5G~5.8G	
NO		
DATE	2020-4-14	

CUSTOMER			
QA CHECKED	ME CHECKED	RF CHECKED	MANAGER CHECKED

--	--	--	--	--

MANAGER CHECKED	MANAGER CHECKED	ME CHECKED	RF CHECKED	LISTER

KESHARE ELECTRON LTD :
ADD: RD 2 XINYUAN DG CITY GD PROVINCE CHINA
TEL: 0769-81195027 FAX: 0769-81193935
MAIL: chung9808@163.com

Revision history

VERSION	DATE	STATE
A1	2020-04-14	A1 SPECIFICATION



Index

		Revision history	1
		Index	2
1		Mechanical Specification	3
	1-1	Mechanical Specification	3
2		Test equipment	4
3		Antenna test data	5
	3-1	VSWR	5
	3-2	Return loss plot	5
	3-3	Smith chart	6
	3-4	No-source test data	6
	3-5	Directional drawing of horizontal plane of	7
	3-6	3D radiation drawing	7
4		Environment Characteristic	8
5		The packing way	9



1. Mechanical Specification

1-1 Mechanical Configuration

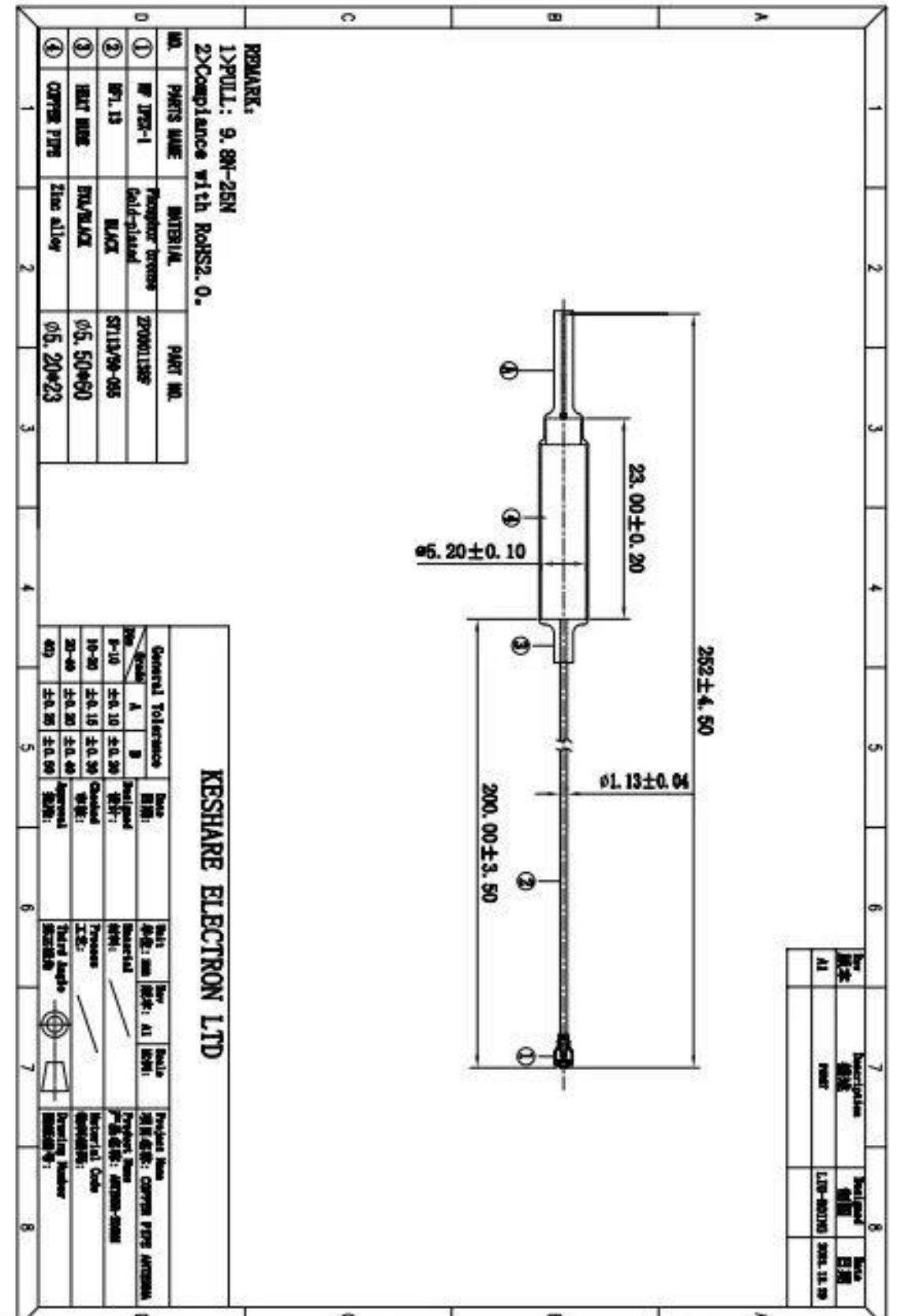

2. Test equipment

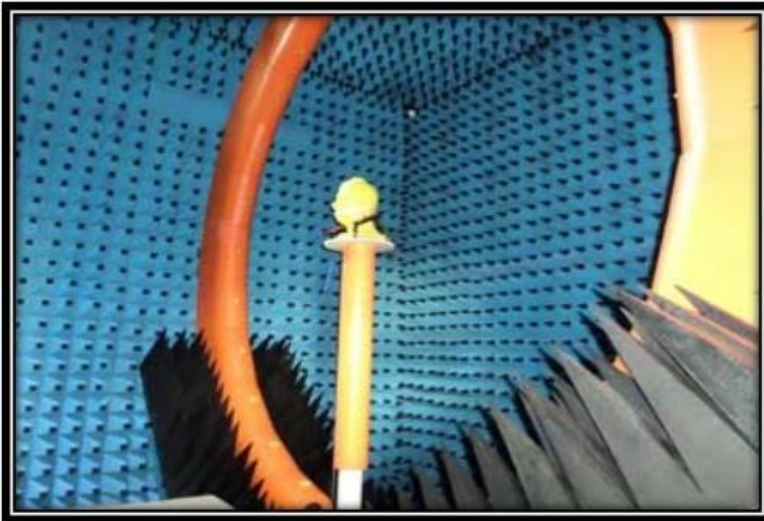

Owned 6 microwave dark room, equipped 2 sets world leading France Satimo SG24 OTA certification test systems (one in SHENZHEN, another one in Shanghai), ETS OTA Standard test system, Blue test reverberation test system which is High repeatability, high accuracy and high resolution. It can quickly provide accurate test reports, fully meet the CITA standards.

Testing range:

Support active, passive testing of GSM/CDMA/WCDMA/TD-SCDMA/LTE/WIFI/WLAN/WiMax/BT/GPS/MIMO/UWB within 0.4-6G.

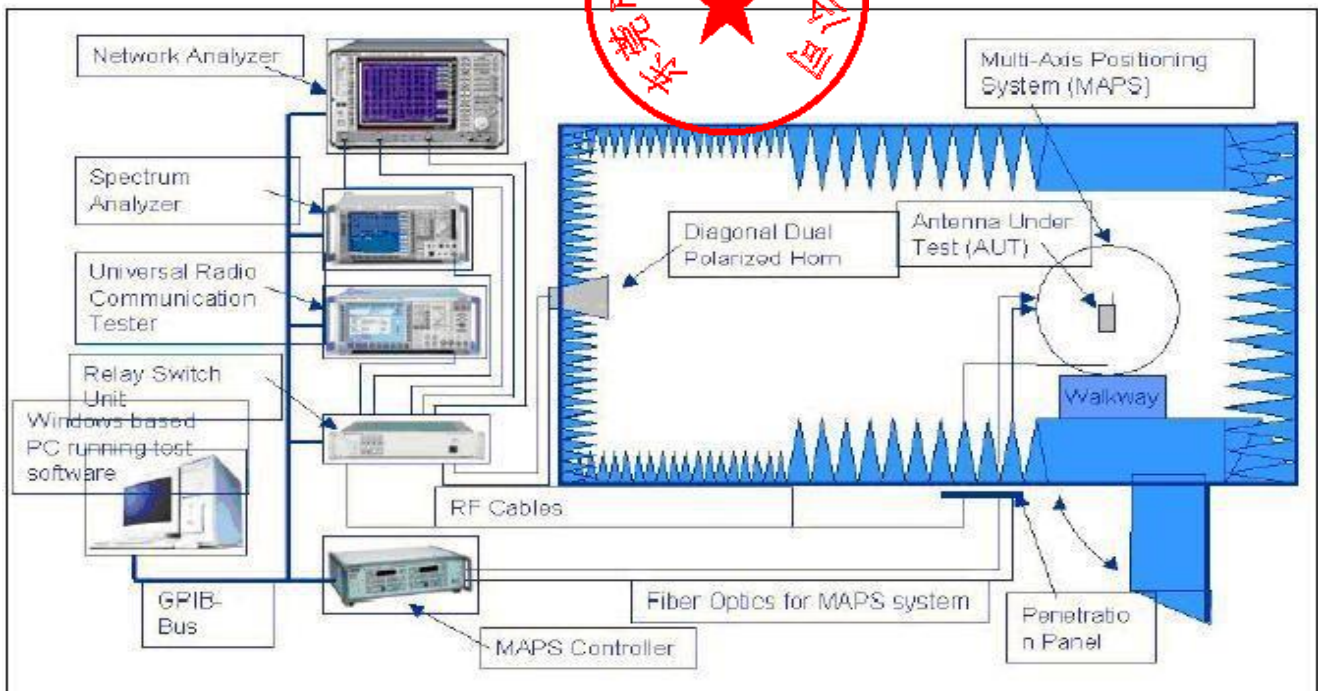

3. Antenna test data

3-1 VSWR

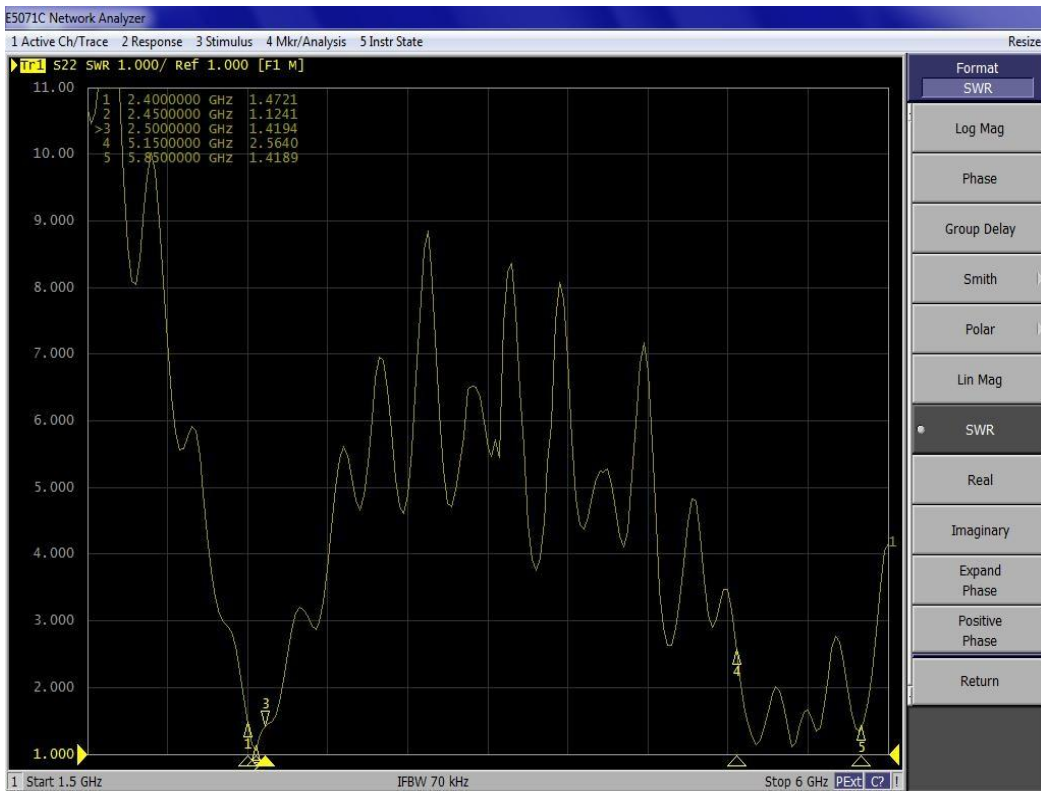

3-2 Return loss plot

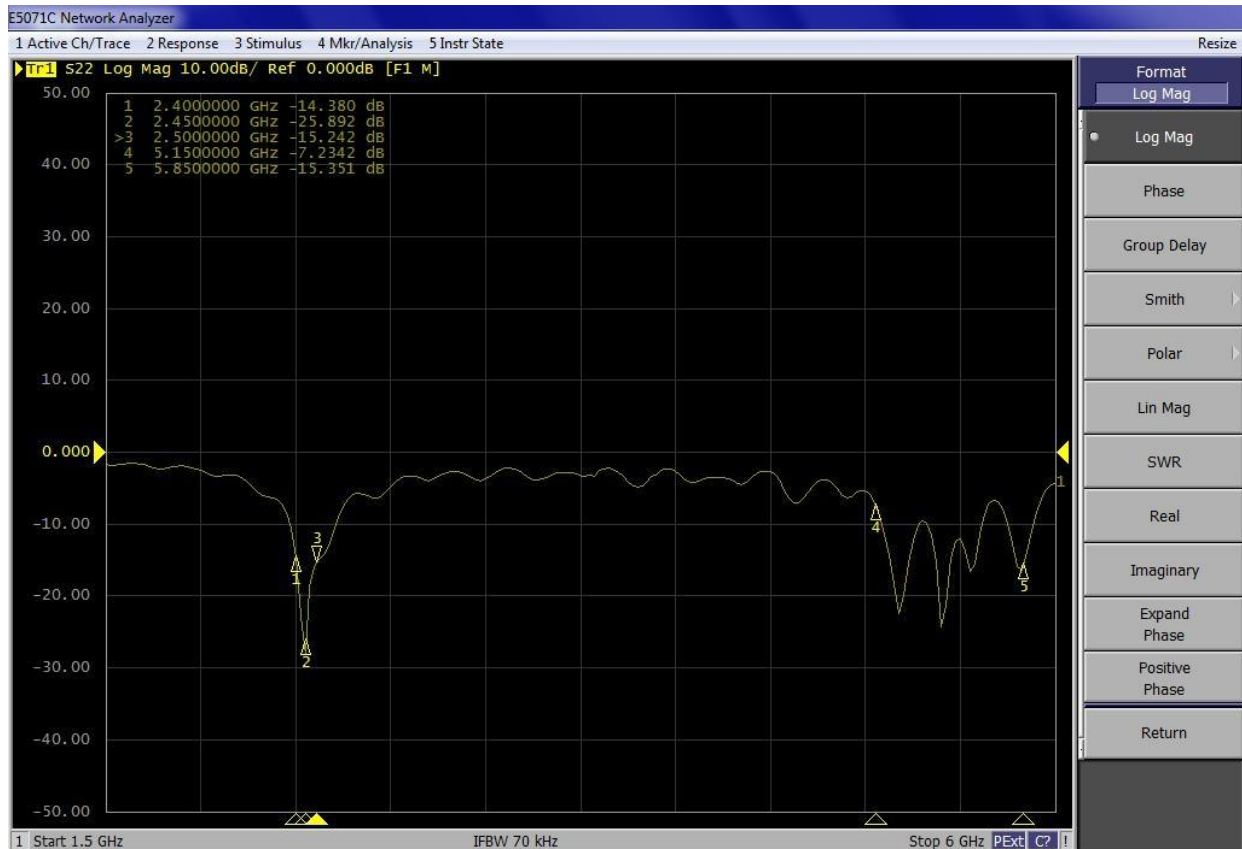

3-3 Smith chart

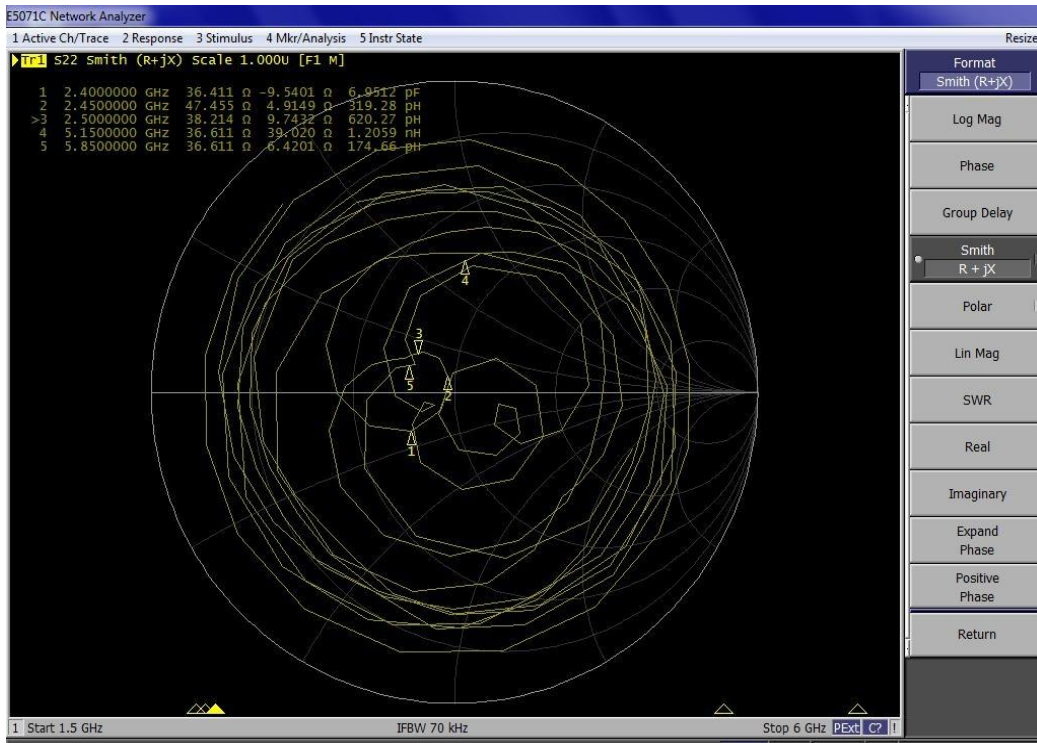

3-4 directional diagram

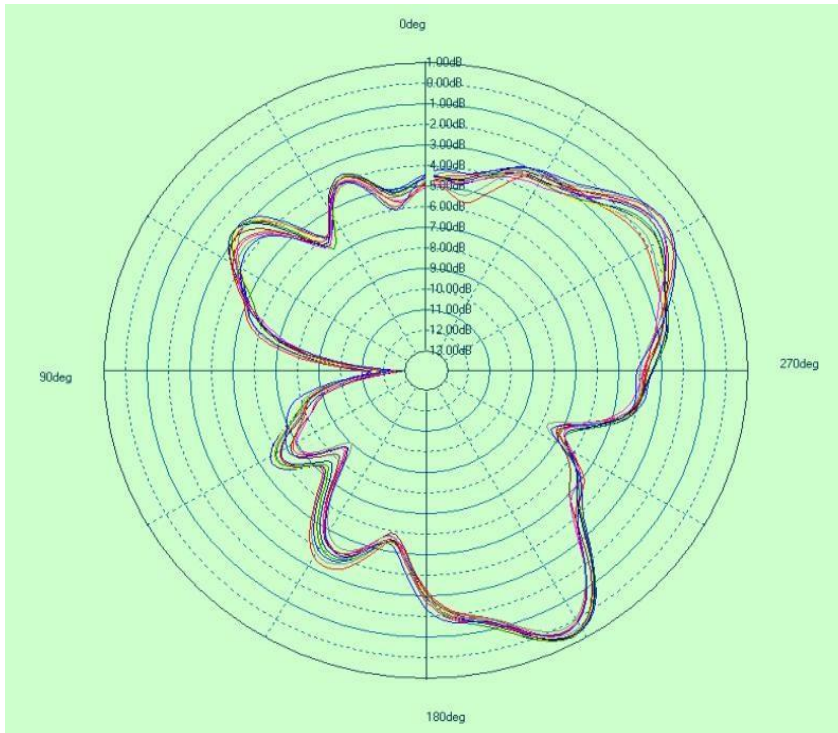

(XY plane Z=0)

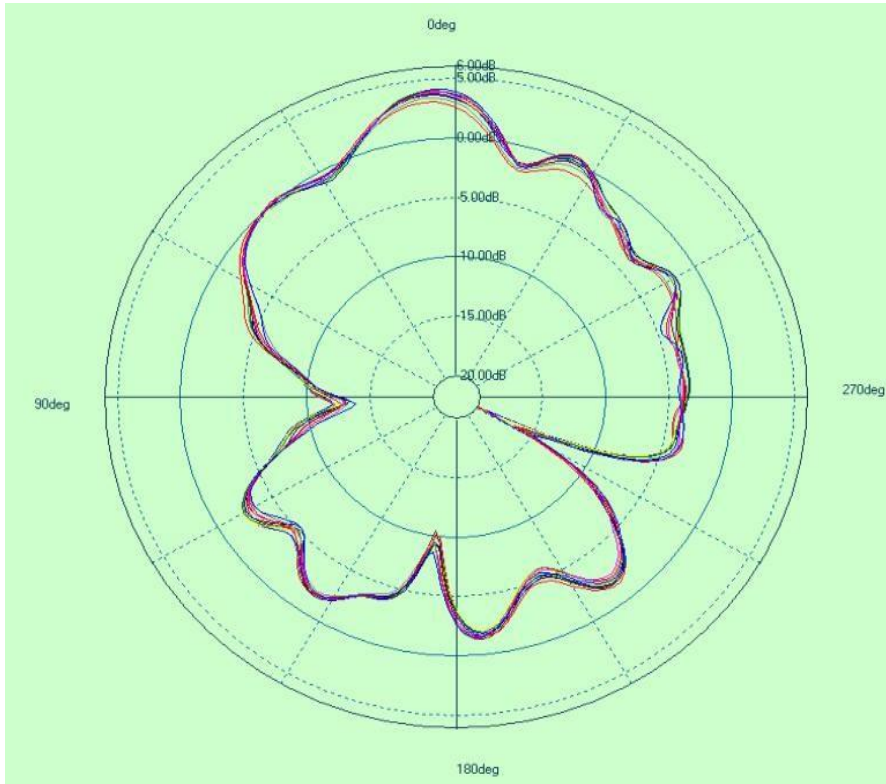

(XZ plane Y=0)

(YZ plane X=0)

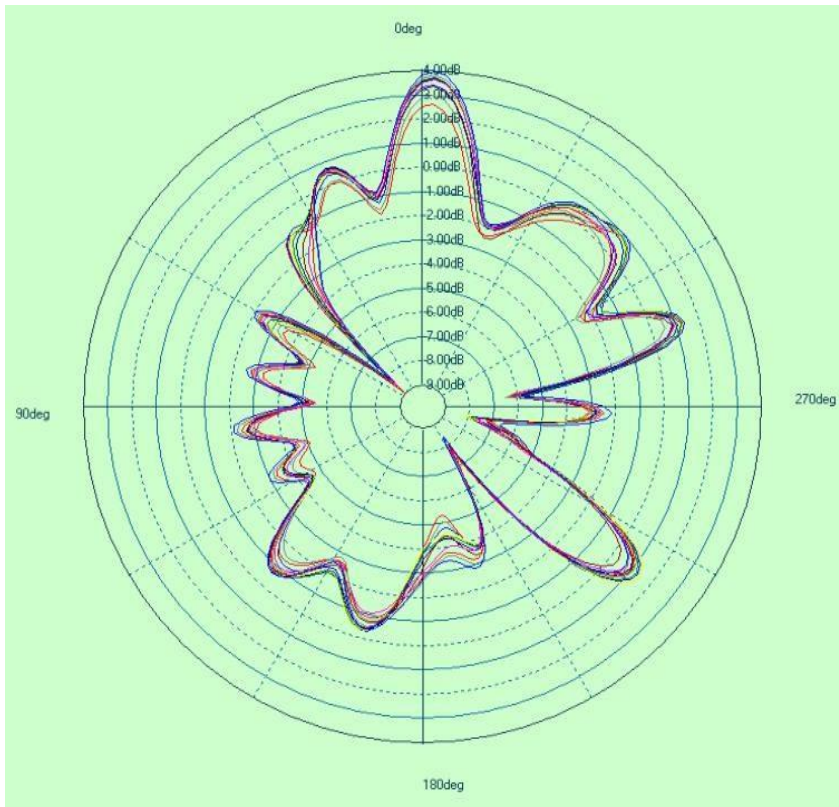

2.4 Apple map

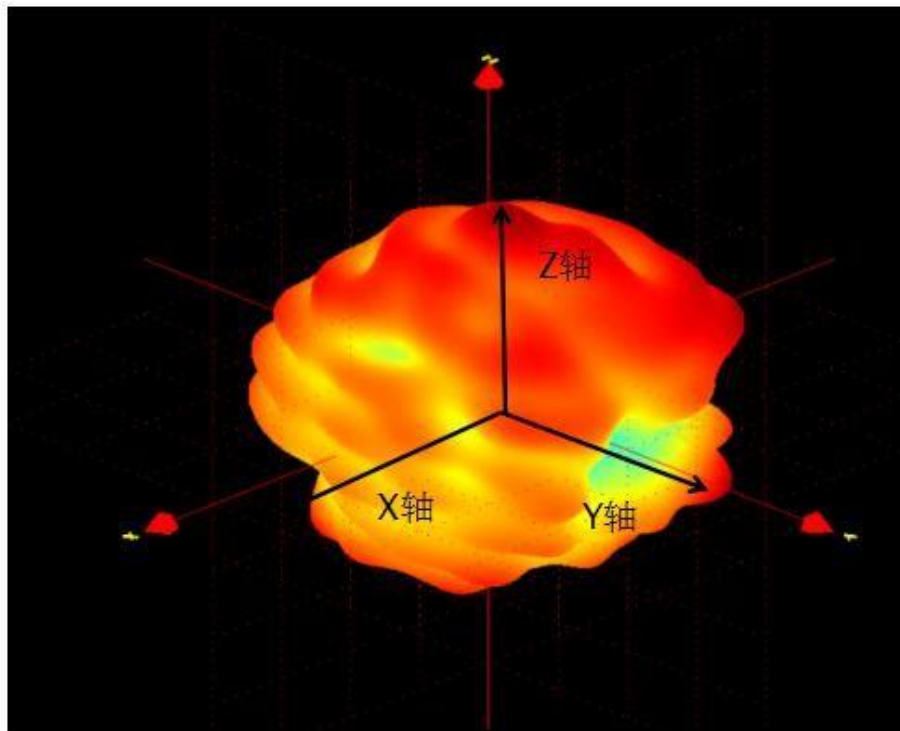

5.8G directional diagram

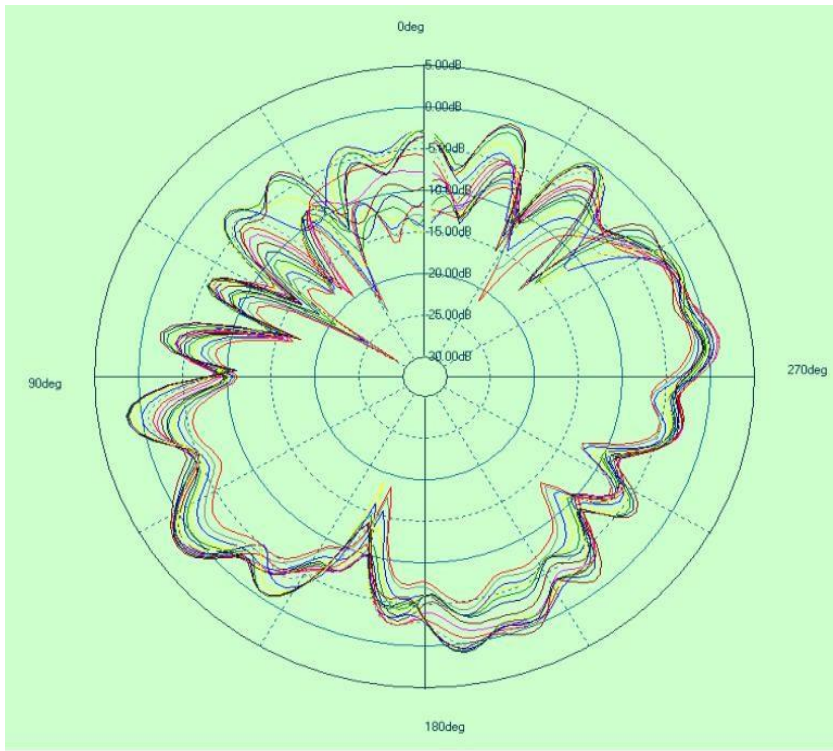

(XY plane Z=0)

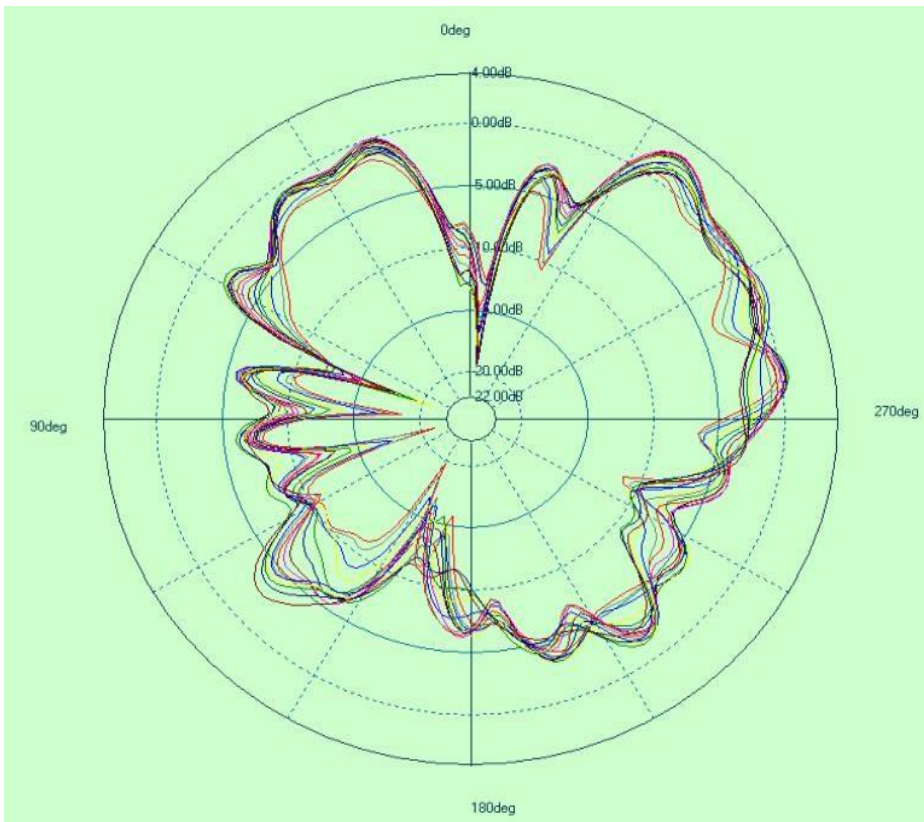

(XZ plane Y=0)

(YZ plane X=0)

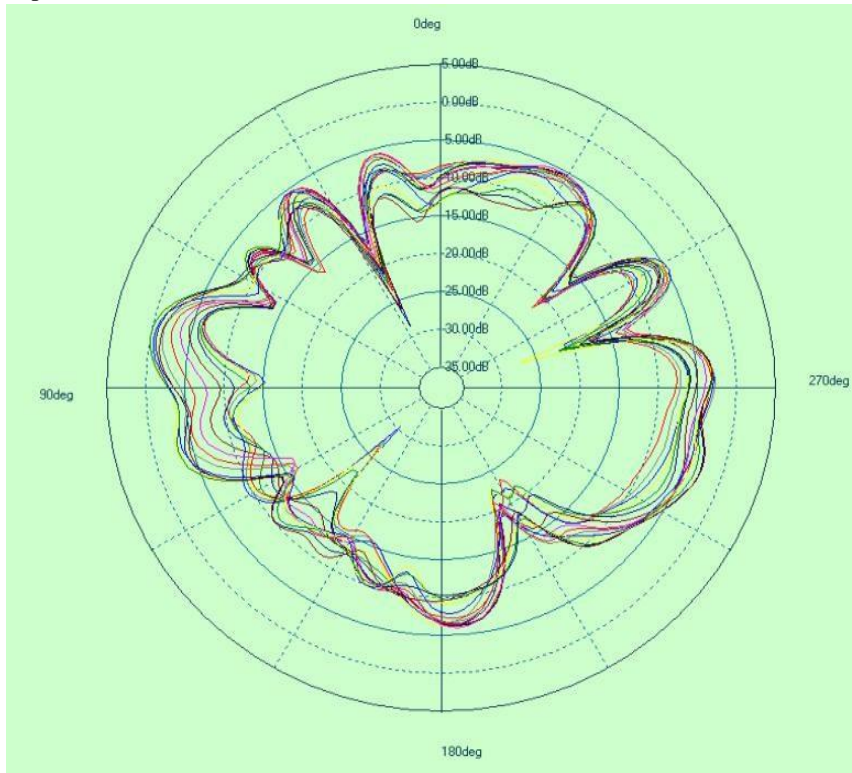

5.8G Apple map

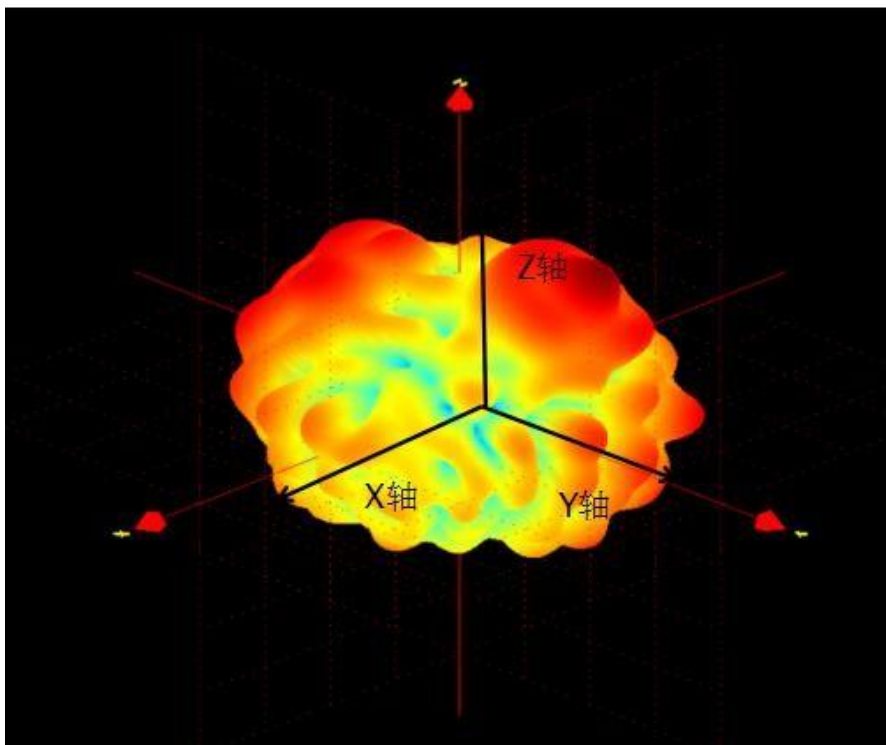

3-5 test data

Frequenc	X-Z plane	Y-Z plane	X-Y plane	E-total	Efficiency
----------	-----------	-----------	-----------	---------	------------

y	Phi=0		Phi=90		theta=90			%
(MHz)	Peak Gain	Average Gain	Peak Gain	Average Gain	Peak Gain	Average Gain	(dBi)	(%)
2400	1.10	-1.52	1.38	-2.02	0.61	0.43	1.61	60
2410	1.11	-1.54	1.40	-2.05	0.62	0.45	1.63	60
2420	1.20	-1.21	1.13	-2.19	0.70	0.36	1.76	59
2430	1.32	-1.91	1.30	-1.88	0.63	0.56	2.00	55
2440	1.31	-1.35	1.21	-1.98	0.81	0.55	1.86	66
2450	1.28	-1.81	1.31	-2.01	0.62	0.55	1.68	62
2460	1.31	-1.72	1.28	-2.05	0.75	0.52	1.84	59
2470	1.25	-1.55	1.19	-1.98	0.68	0.53	1.68	63
2480	1.24	-1.65	1.32	-1.95	0.61	0.54	1.75	61
2490	1.31	-1.63	1.26	-1.89	0.71	0.53	1.72	68
2500	1.33	-1.64	1.28	-2.03	0.69	0.55	1.73	65
5000	1.18	-1.58	1.27	-2.05	0.68	0.56	1.82	66
5050	1.24	-1.64	1.19	-2.01	0.81	0.71	1.92	56
5100	1.33	-1.38	1.31	-2.03	0.78	0.68	1.88	62
5150	1.28	-1.49	1.35	-1.98	0.68	0.59	1.93	63
5200	1.24	-1.64	1.38	-1.89	0.71	0.62	1.68	67
5250	1.28	-1.56	1.35	-1.88	0.68	0.65	1.69	68
5300	1.19	-1.88	1.36	-1.85	0.69	0.66	1.70	65
5350	1.32	-1.76	1.29	-1.79	0.72	0.75	1.68	66
5400	1.35	-1.81	1.24	-1.82	0.77	0.71	1.70	71
5450	1.32	-1.65	1.28	-1.76	0.70	0.69	1.69	66
5500	1.28	-1.68	1.31	-1.83	0.69	0.71	1.75	62
5550	1.29	-1.69	1.26	-1.88	0.68	0.72	1.72	59
5600	1.34	-1.59	1.29	-1.79	0.67	0.68	1.73	63
5650	1.29	-1.66	1.30	-1.91	0.67	0.69	1.69	58
5700	1.33	-1.59	1.28	-1.83	0.76	0.70	1.72	67
5750	1.34	-1.71	1.27	-1.90	0.75	0.69	1.73	69
5800	1.18	-1.73	1.28	-1.82	0.78	0.68	1.66	63
5850	1.17	-1.70	1.27	-1.80	0.77	0.67	1.63	63



4. Environment Characteristic

NO.	ITEM	TEST CONDITION	SPECIFICATION
4-1	High Temperature/Humidity Storage Test(non operating)	1. Temperature: $+80 \pm 2^{\circ}\text{C}$ 2. Humidity: $90\sim 95\% \text{RH}$ 3. Time: 48hrs	No material deformation is allowed.
4-2	Low Temperature/Humidity Storage Test(non operating)	1. Temperature: $-30 \pm 2^{\circ}\text{C}$ 2. Humidity: $0\% \text{RH}$ 3. Time: 48hrs	The VSWR, Gain, Radiation Pattern must be met specifications after these tests.

