



# FCC TEST REPORT

**Test report  
On Behalf of  
Shenzhen Jiuyang Technology Co., Ltd  
For  
Foldable Wireless Charger Alarm Clock  
Model No.: JY - 01  
FCC ID: 2BG4HJY-01**

**Prepared for :** Shenzhen Jiuyang Technology Co., Ltd  
Room 401, Building 7, Yahao Xuan, No. 502 Jian'an 1st Road, Wenhui Community,  
Xin'an Street, Bao'an District, Shenzhen, China

**Prepared By :** Shenzhen Tongzhou Testing Co.,Ltd  
1th Floor, Building 1, Haomai High-tech Park, Huating Road 387, Dalang  
Street, Longhua, Shenzhen, China

**Date of Test:** 2024/6/5 ~ 2024/6/13

**Date of Report:** 2024/6/14

**Report Number:** TZ240605811-E1

The test report apply only to the specific sample(s) tested under stated test conditions  
It is not permitted to copy extracts of these test result without the written permission of the test  
laboratory.



## TEST RESULT CERTIFICATION

**Applicant's name** ..... : Shenzhen Jiuyang Technology Co., Ltd  
Room 401, Building 7, Yahao Xuan, No. 502 Jian'an 1st Road,  
**Address** ..... : Wenhui Community, Xin'an Street, Bao'an District, Shenzhen,  
China

**Manufacture's Name**..... : Shenzhen Jiuyang Technology Co., Ltd  
Room 401, Building 7, Yahao Xuan, No. 502 Jian'an 1st Road,  
**Address** ..... : Wenhui Community, Xin'an Street, Bao'an District, Shenzhen,  
China

### Product description

**Trade Mark** ..... : N/A  
**Product name** ..... : Foldable Wireless Charger Alarm Clock  
**Model**..... : JY - 01

**Standards** ..... : FCC Rules and Regulations Part 15 Subpart C (Section 15.209),  
ANSI C63.10: 2013

This publication may be reproduced in whole or in part for non-commercial purposes as long as the Shenzhen Tongzhou Testing Co.,Ltd is acknowledged as copyright owner and source of the material. Shenzhen Tongzhou Testing Co.,Ltd takes no responsibility for and will not assume liability for damages resulting from the reader's interpretation of the reproduced material due to its placement and context.

**Date of Test** ..... :  
**Date (s) of performance of tests** ..... : 2024/6/5 ~ 2024/6/13  
**Date of Issue**..... : 2024/6/14  
**Test Result**..... : **Pass**

Testing Engineer : Allen Lai  
(Allen Lai)

Technical Manager : Hugo Chen  
(Hugo Chen)

Authorized Signatory : Andy Zhang  
(Andy Zhang)



<b>Table of Contents</b>		<b>Page</b>
<b>1 TEST SUMMARY</b> .....		<b>4</b>
1.1	TEST PROCEDURES AND RESULTS .....	4
1.2	TEST FACILITY .....	4
1.3	MEASUREMENT UNCERTAINTY.....	4
<b>2 GENERAL INFORMATION</b> .....		<b>5</b>
2.1	General Description of EUT .....	5
2.2	Operation of EUT during testing .....	6
2.3	Description of Test Setup.....	6
2.4	Description of Test Facility .....	6
<b>3 Measurement Instruments List</b> .....		<b>8</b>
<b>4 CONDUCTED EMISSION TEST</b> .....		<b>9</b>
4.1	Block Diagram of Test Setup .....	9
4.2	Conducted Power Line Emission Limit.....	9
4.3	Test Procedure .....	9
4.4	Test Result.....	9
<b>5 Bandwidth</b> .....		<b>12</b>
5.1	Block Diagram of Test Setup .....	12
5.2	Rules and specifications .....	12
5.3	Test Procedure .....	12
5.4	Test Result.....	13
<b>6 RADIATED EMISSIONS</b> .....		<b>14</b>
6.1	Block Diagram of Test Setup .....	14
6.2	Rules and specifications .....	15
6.3	Test Procedure .....	16
6.4	Test Result.....	16
<b>7 ANTENNA REQUIREMENT</b> .....		<b>19</b>
<b>7. TEST SETUP Photographs of EUT</b> .....		<b>20</b>
<b>8. Exterior Photographs of the EUT</b> .....		<b>20</b>
<b>9. INTERIOR Photographs of the EUT</b> .....		<b>20</b>



## 1 TEST SUMMARY

### 1.1 TEST PROCEDURES AND RESULTS

DESCRIPTION OF TEST	RESULT
CONDUCTED EMISSIONS TEST	COMPLIANT
RADIATED EMISSION TEST	COMPLIANT
OCCUPIED BANDWIDTH MEASUREMENT	COMPLIANT
ANTENNA REQUIREMENT	COMPLIANT

### 1.2 TEST FACILITY

Test Firm : Shenzhen Tongzhou Testing Co.,Ltd

Address 1th Floor, Building 1, Haomai High-tech Park, Huating Road 387,  
Dalang Street, Longhua, Shenzhen, China

### 1.3 MEASUREMENT UNCERTAINTY

Measurement Uncertainty	
Conducted Emission Expanded Uncertainty	= 2.23dB, k=2
Radiated emission expanded uncertainty(9kHz-30MHz)	= 3.08dB, k=2
Radiated emission expanded uncertainty(30MHz-1000MHz)	= 4.42dB, k=2
Radiated emission expanded uncertainty(Above 1GHz)	= 4.06dB, k=2



## 2 GENERAL INFORMATION

### 2.1 General Description of EUT

Equipment	Foldable Wireless Charger Alarm Clock
Model Name	JY - 01
Model Difference	N/A
Test Model	JY - 01
Trade Mark	N/A
FCC ID	2BG4HJY-01
Antenna Type	Coil Antenna
Antenna Gain	0dBi
Operation frequency	110.5– 205 KHz
Test Frequency	146.8 KHz
Modulation Type	ASK
Power Rating	Input: 12V $\overline{=}$ 1.5A Output: 5V $\overline{=}$ 1A, 7.5V $\overline{=}$ 1A, 9V $\overline{=}$ 1.12A (Wireless charger)
Test Sample ID	TZ240605811-1#



## 2.2 Operation of EUT during testing

<b>Test Modes:</b>		
Mode 1	AC/DC Adapter + EUT + Wireless charger tester (Load 10W)	Record
Mode 2	AC/DC Adapter + EUT + Wireless charger tester (Load 7.5W)	Pre-test
Mode 3	AC/DC Adapter + EUT + Wireless charger tester (Load 5W)	Pre-test

Note: All test modes were pre-tested, but we only recorded the worst case in this report.

## 2.3 Description of Test Setup

Operation of EUT during testing

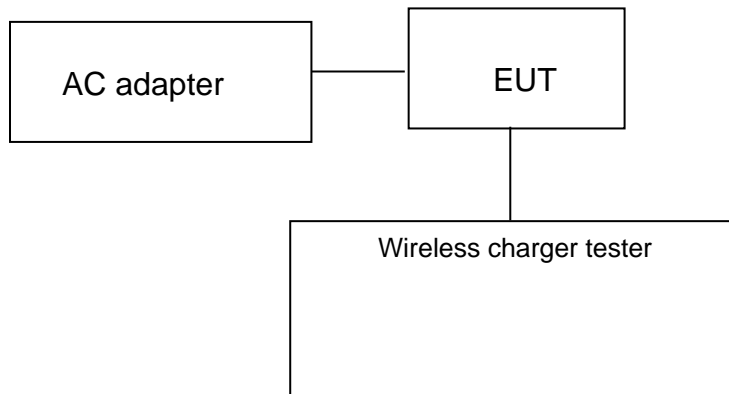

Setup: Transmission mode

- AC adapter information  
Model: M20-C20AUS  
Input: 100-240VAC, 50/60Hz 0.6A  
Output : 5V $\overline{=}$ 3A, 9V $\overline{=}$ 2.22A, 12V $\overline{=}$ 1.67A
- Wireless charger tester information  
Manufacturer: YBZ

## 2.4 Description of Test Facility

### FCC

Designation Number: CN1275

Test Firm Registration Number: 167722

Shenzhen Tongzhou Testing Co.,Ltd has been listed on the US Federal Communications Commission

list of test facilities recognized to perform electromagnetic emissions measurements.

### A2LA

Certificate Number: 5463.01

Shenzhen Tongzhou Testing Co.,Ltd has been listed by American Association for Laboratory Accreditation to perform electromagnetic emission measurement.



**IC**

ISED#: 22033

CAB identifier: CN0099

Shenzhen Tongzhou Testing Co.,Ltd has been listed by Innovation, Science and Economic Development Canada to perform electromagnetic emission measurement.

The 3m-Semi anechoic test site fulfils CISPR 16-1-4 according to ANSI C63.10 and CISPR 16-1-4:2010



### 3 MEASUREMENT INSTRUMENTS LIST

Item	Test Equipment	Manufacturer	Model No.	Serial No.	Calibration Date	Calibration Due Date
1	Wideband Antenna	schwarzbeck	VULB 9163	958	2022/11/13	2025/11/12
2	EMI Test Receiver	R&S	ESCI	100849/003	2024/1/4	2025/1/3
3	Controller	MF	MF7802	N/A	N/A	N/A
4	RF Cable(below 1GHz)	HUBER+SUHNER	RG214	N/A	2024/1/4	2025/1/3
5	RF Cable(above 1GHz)	HUBER+SUHNER	RG214	N/A	2024/1/4	2025/1/3
6	RE test software	Tonscend	JS32-RE	V5.0.0.0	N/A	N/A
7	Loop Antenna	schwarzbeck	FMZB 1519 B	00023	2022/11/13	2025/11/12
8	Artificial Mains	ROHDE & SCHWARZ	ENV 216	101333-IP	2024/1/4	2025/1/3
9	EMI Test Software	ROHDE & SCHWARZ	ESK1	V1.71	N/A	N/A
10	MXA Signal Analyzer	Keysight	N9020A	MY52091623	2024/1/4	2025/1/3



## 4 CONDUCTED EMISSION TEST

### 4.1 Block Diagram of Test Setup

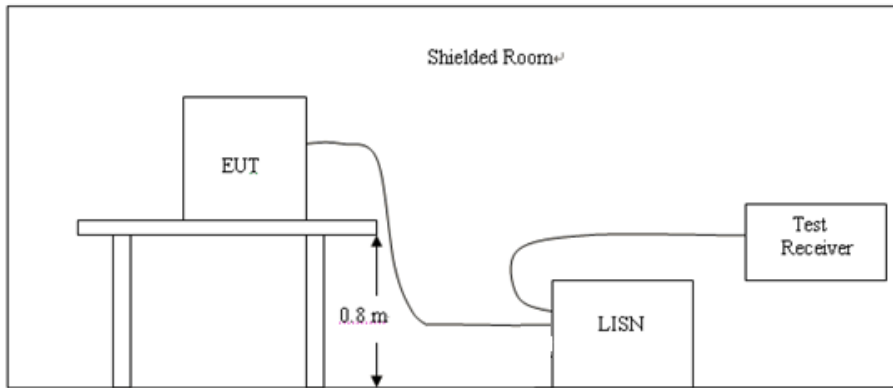

### 4.2 Conducted Power Line Emission Limit

According to FCC Part 15.207(a)

Frequency (MHz)	Maximum RF Line Voltage (dB $\mu$ V)			
	CLASS A		CLASS B	
	Q.P.	Ave.	Q.P.	Ave.
0.15 - 0.50	79	66	66-56*	56-46*
0.50 - 5.00	73	60	56	46
5.00 - 30.0	73	60	60	50

\* Decreasing linearly with the logarithm of the frequency

For intentional device, according to §15.207 Line Conducted Emission Limit is same as above table.

### 4.3 Test Procedure

- 1, The equipment was set up as per the test configuration to simulate typical actual usage per the user's manual. The EUT is a tabletop system, a wooden table with a height of 0.8 meters is used and is placed on the ground plane as per ANSI C63.10.
- 2, Support equipment, if needed, was placed as per ANSI C63.10.
- 3, All I/O cables were positioned to simulate typical actual usage as per ANSI C63.10.
- 4, If a EUT received DC power from the USB Port of Notebook PC, the PC's adapter received AC120V/60Hz power through a Line Impedance Stabilization Network (LISN) which supplied power source and was grounded to the ground plane.
- 5, All support equipments received AC power from a second LISN, if any.
- 6, The EUT test program was started. Emissions were measured on each current carrying line of the EUT using a spectrum Analyzer / Receiver connected to the LISN powering the EUT. The LISN has two monitoring points: Line 1 (Hot Side) and Line 2 (Neutral Side). Two scans were taken: one with Line 1 connected to Analyzer / Receiver and Line 2 connected to a 50 ohm load; the second scan had Line 1 connected to a 50 ohm load and Line 2 connected to the Analyzer / Receiver.
- 7, Analyzer / Receiver scanned from 150 KHz to 30MHz for emissions in each of the test modes

### 4.4 Test Result

PASS



Temperature	22.8°C	Humidity	55%
Test Engineer	Tony Luo	Configurations	Mode 1

Please refer to following diagram for individual

**Neutral Line**

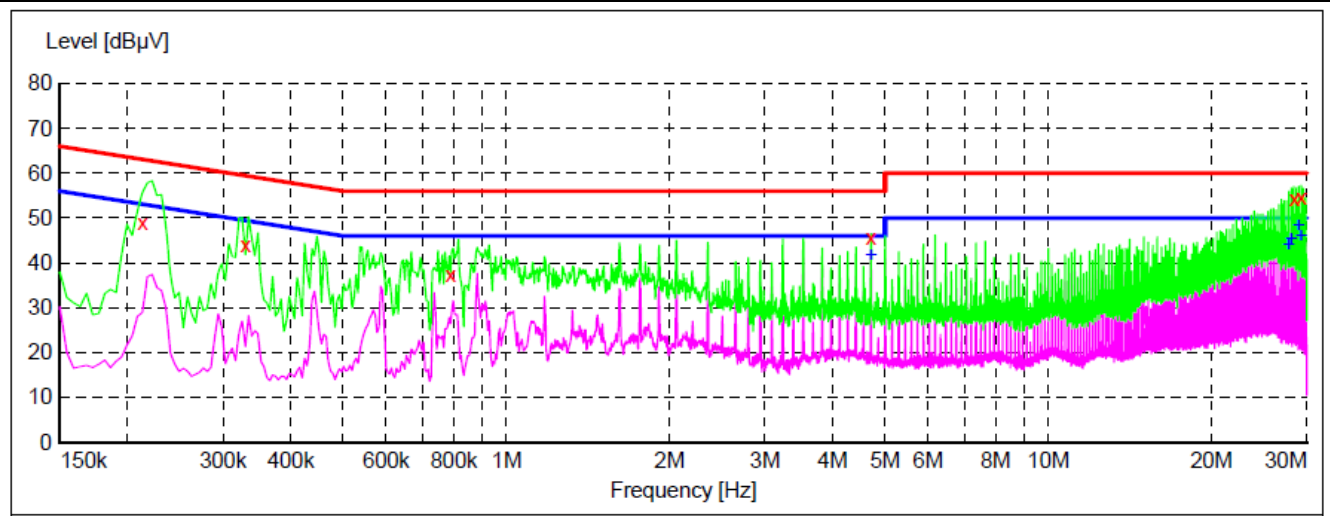

Frequency MHz	Level dBµV	Transd dB	Limit dBµV	Margin dB	Detector	Line	PE
0.213000	48.80	10.6	63	14.3	QP	N	GND
0.330000	43.80	10.1	60	15.7	QP	N	GND
0.789000	37.30	9.8	56	18.7	QP	N	GND
4.708500	45.70	9.7	56	10.3	QP	N	GND
28.401000	54.30	10.1	60	5.7	QP	N	GND
29.283000	54.50	10.1	60	5.5	QP	N	GND
Frequency MHz	Level dBµV	Transd dB	Limit dBµV	Margin dB	Detector	Line	PE
4.708500	41.50	9.7	46	4.5	AV	N	GND
27.811500	43.90	10.1	50	6.1	AV	N	GND
28.108500	45.40	10.1	50	4.6	AV	N	GND
28.990500	48.20	10.1	50	1.8	AV	N	GND
29.287500	45.90	10.1	50	4.1	AV	N	GND

Note:

1. Margin(dB)= Limit(dBµV) - Level(dBµV)
2. If QP Result complies with AV limit, AV Result is deemed to comply with AV limit.
3. Test setup: RBW: 9 kHz (150 kHz—30 MHz), Step size: 4 kHz, Scan time: auto.
4. Pre-scan all modes and recorded the worst case result in this report

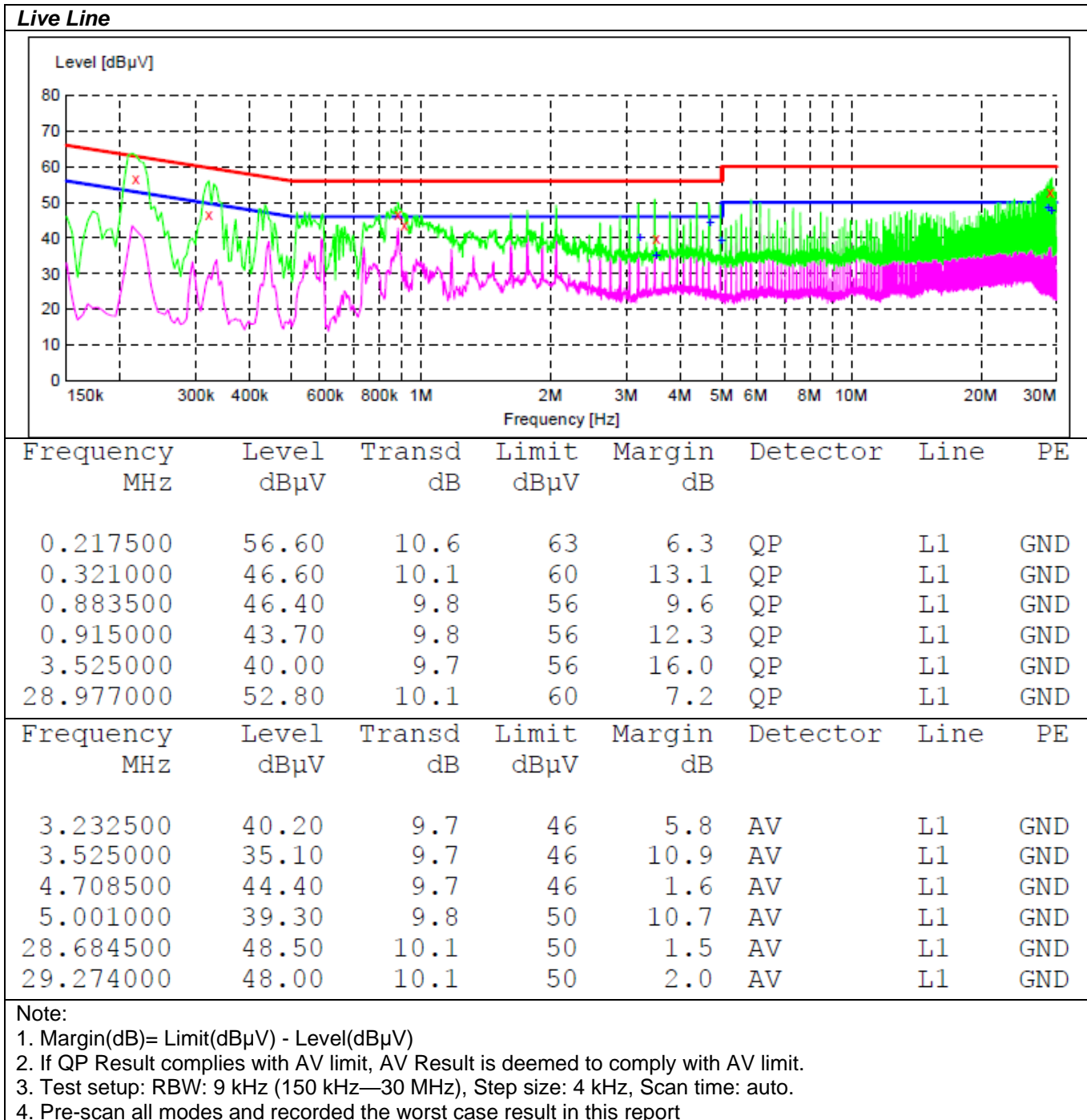

## 5 BANDWIDTH

### 5.1 Block Diagram of Test Setup

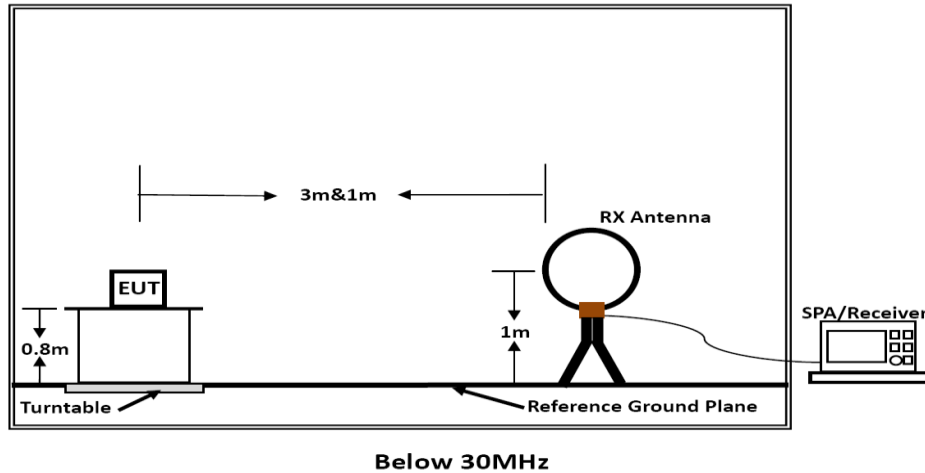

### 5.2 Rules and specifications

CFR 47 Part 15.215(c)

ANSI C63.10-2013

### 5.3 Test Procedure

Intentional radiators operating under the alternative provisions to the general emission limits, as contained in §§15.217 through 15.257 and in subpart E of this part, must be designed to ensure that 20dB bandwidth of the emission, or whatever bandwidth may otherwise be specified in the specific rule section under which the equip compliance with the 20dB attenuation specification may base on measurement at the intentional radiator's antenna output terminal unless the intentional radiator uses a permanently attached antenna, in which case compliance shall be demonstrated by measuring the radiated emissions.



5.4 Test Result  
PASS

Temperature	22.8°C	Humidity	55%
Test Engineer	Tony Luo	Configurations	Mode 1

Mode	Freq (KHz)	20dB Bandwidth (Hz)	Limit (kHz)	Conclusion
Tx Mode	146.8	484.5	/	PASS

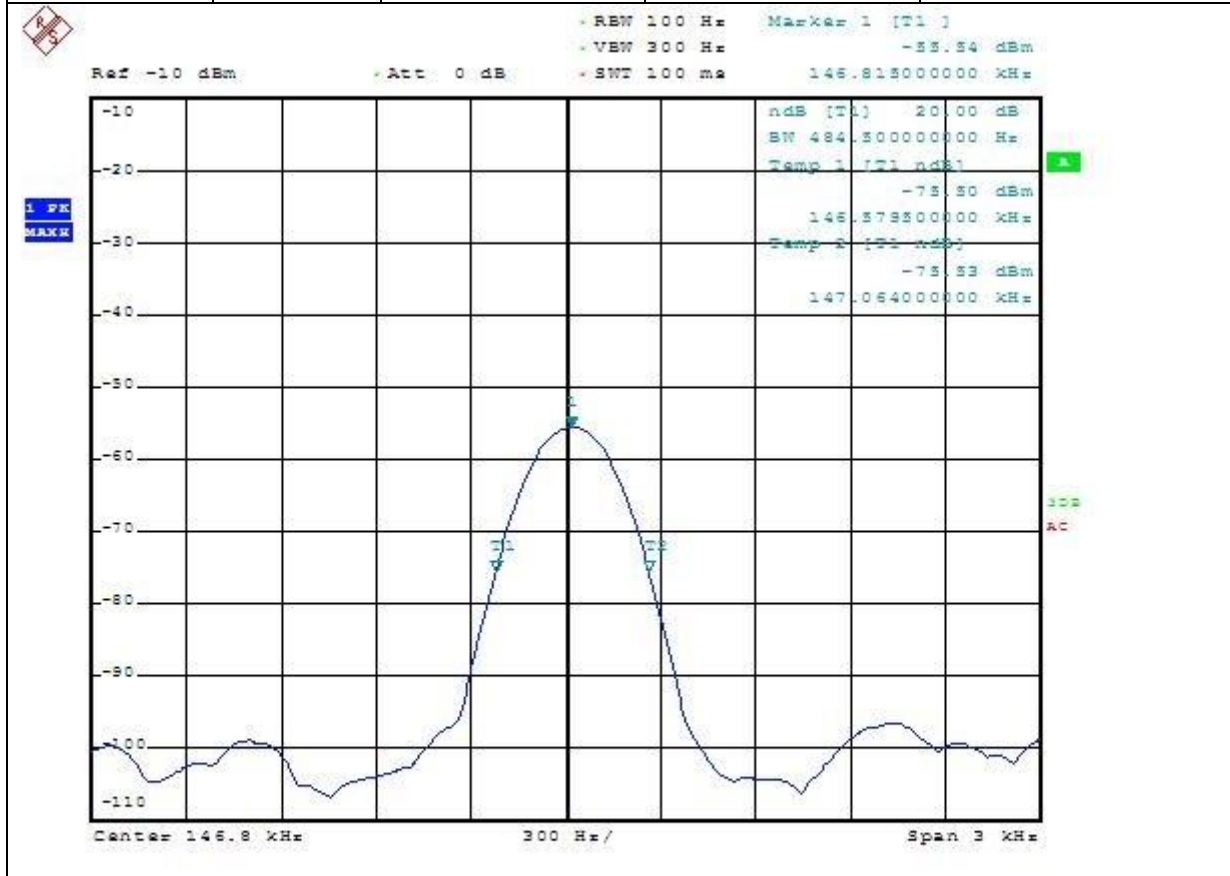

Date: 1.JAN.2003 09:37:54

## 6 RADIATED EMISSIONS

### 6.1 Block Diagram of Test Setup

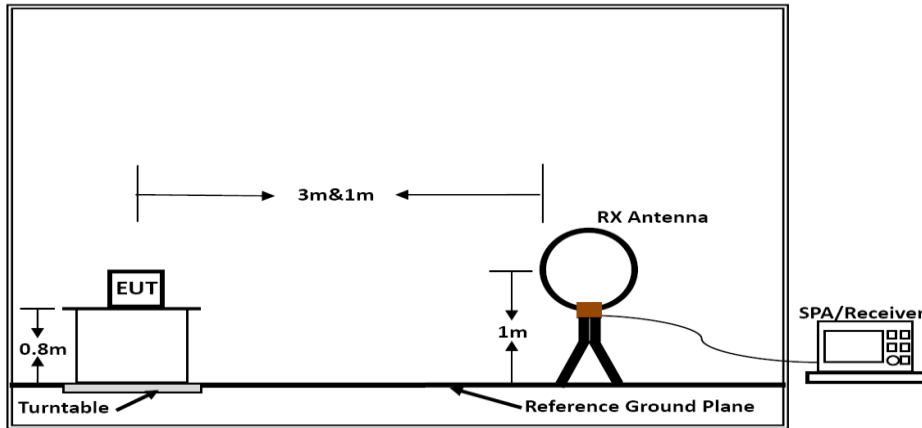

**Below 30MHz**

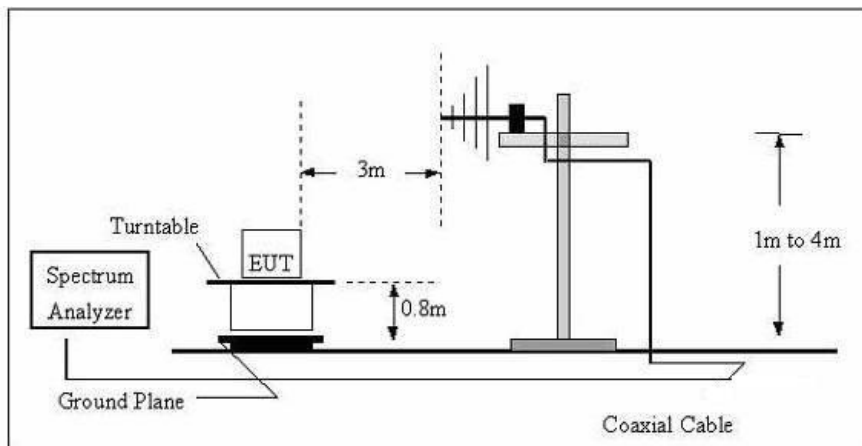



## 6.2 Rules and specifications

CFR 47 Part 15, section 15.205

Only spurious emissions are permitted in any of the frequency bands listed the tables in these sections.

MHz	MHz	MHz	GHz
0.090-0.110	16.42-16.423	399.9-410	4.5-5.15
1\ 0.495-0.505	16.69475-16.69525	608-614	5.35-5.46
2.1735-2.1905	16.80425-16.80475	960-1240	7.25-7.75
4.125-4.128	25.5-25.67	1300-1427	8.025-8.5
4.17725-4.17775	37.5-38.25	1435-1626.5	9.0-9.2
4.20725-4.20775	73-74.6	1645.5-1646.5	9.3-9.5
6.215-6.218	74.8-75.2	1660-1710	10.6-12.7
6.26775-6.26825	108-121.94	1718.8-1722.2	13.25-13.4
6.31175-6.31225	123-138	2200-2300	14.47-14.5
8.291-8.294	149.9-150.05	2310-2390	15.35-16.2
8.362-8.366	156.52475-156.52525	2483.5-2500	17.7-21.4
8.37625-8.38675	156.7-156.9	2690-2900	22.01-23.12
8.41425-8.41475	162.0125-167.17	3260-3267	23.6-24.0
12.29-12.293	167.72-173.2	3332-3339	31.2-31.8
12.51975-12.52025	240-285	3345.8-3358	36.43-36.5
12.57675-12.57725	322-335.4	3600-4400	(\2)
13.36-13.41			

CFR 47 Part 15, section 15.209

The emissions from an intentional radiator shall not exceed the limits in the tables in these sections using an average detector

Frequency (MHz)	Field strength (microvolts/meter)	Measurement distance (meters)
0.009–0.490	2400/F (kHz)	300
0.490–1.705	24000/F (kHz)	30
1.705–30.0	30	30
30–88	100**	3
88–216	150**	3
216–960	200**	3
Above 960	500	3

Limit calculation and transfer to 3m distance as showed in the following table:

Frequency (MHz)	Limit (dBuV/m)	Distance (m)
0.009-0.490	$20\log(2400/F(KHz))+40\log(300/3)$	3
0.490-1.705	$20\log(24000/F(KHz))+40\log(30/3)$	3
1.705-30.0	69.5	3
30-88	40.0	3
88-216	43.5	3
216-960	46.0	3
Above 960	54.0	3

CFR 47 Part 15, section 15.35

When average radiated emission measurements are specified, the limit on the peak level of the radio Frequency emission is 20dB above the maximum permitted average emission limit.

Transmitter Spurious Emissions 9KHz-30MHz			
	9-150KHz	150-490KHz	490KHz-30MHz
Resolution Bandwidth	200Hz	9KHz	9KHz
Video Bandwidth	2KHz	100KHz	100KHz
Detector	Peak	Peak	Peak
Trace Mode	Max Hold	Max Hold	Max Hold
Sweep Time	Auto	Auto	Auto



### 6.3 Test Procedure

Measurement distance 3m

For the measurement range up to 30MHz in the following plots the field strength result from 3m Distance measurement are extrapolated to 300m and 30m distance respectively, by 40dB/decade, According to part 15.31(f)(2), per antenna factor scaling.

Measurements below 1000MHz are performed with a peak detector and compared to average limits, Measurements with an average detector are not required.

Note:

For battery operated equipment, the equipment tests shall be performed using a new battery.

### 6.4 Test Result

PASS

Temperature	22.8°C	Humidity	55%
Test Engineer	Tony Luo	Configurations	Mode 1

For 9KHz-30MHz

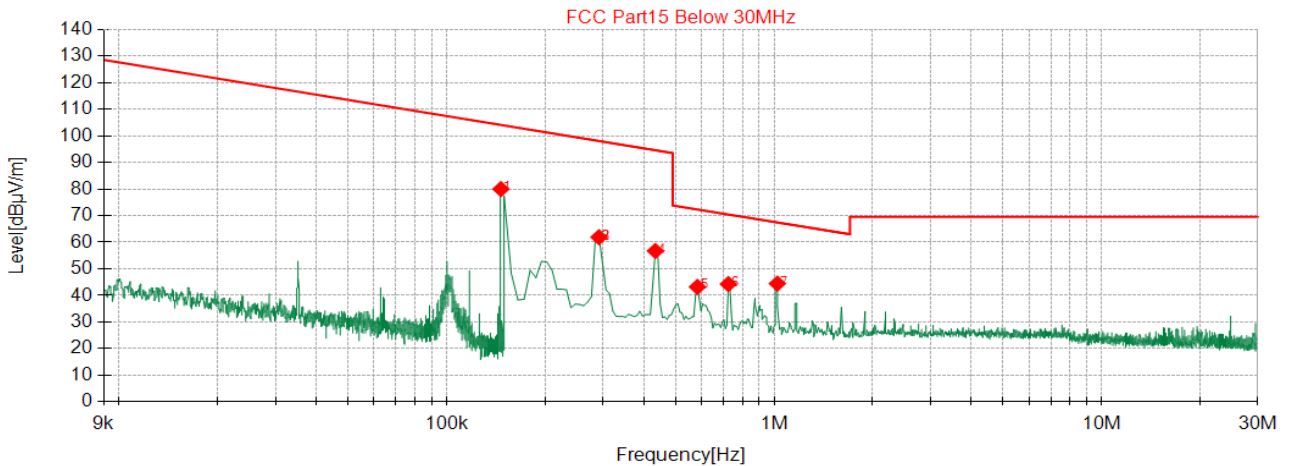

◆ QP Detector

Suspected Data List									
NO.	Freq. [MHz]	Reading [dBµV]	Factor [dB/m]	Level [dBµV/m]	Limit [dBµV/m]	Margin [dB]	Height [cm]	Angle [°]	Polarity
1	0.146	60.10	19.86	79.96	104.08	24.12	100	146	Vertical
2	0.291	41.83	20.06	61.89	98.04	36.15	100	142	Vertical
3	0.291	41.83	20.06	61.89	98.04	36.15	100	142	Vertical
4	0.433	36.49	20.22	56.71	94.57	37.86	100	134	Vertical
5	0.582	22.90	20.30	43.20	72.30	29.10	100	134	Vertical
6	0.724	23.96	20.30	44.26	70.41	26.15	100	142	Vertical
7	1.023	24.15	20.30	44.45	67.42	22.97	100	142	Vertical

Note:

1 · Level [dBµA/m] = Reading [dBµV] + Factor[dB/m]

2 · Margin[dB] = Limit [dBµV/m] - Level [dBµV/m]

3 · Measured at antenna position coaxial and coplanar, only record the Coaxial.





For 30MHz-1GHz

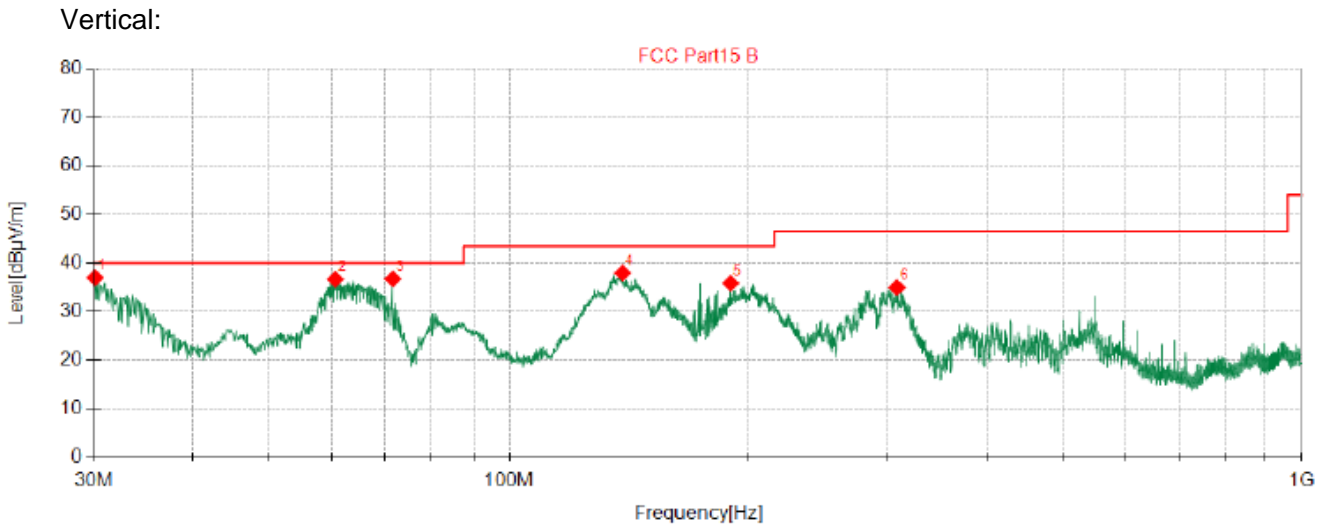

Suspected Data List									
NO.	Freq. [MHz]	Reading [dBµV]	Factor [dB/m]	Level [dBµV/m]	Limit [dBµV/m]	Margin [dB]	Height [cm]	Angle [°]	Polarity
1	30.12	53.21	-16.21	37.00	40.00	3.00	100	325	Vertical
2	60.55	52.46	-15.79	36.67	40.00	3.33	100	112	Vertical
3	71.58	55.26	-18.51	36.75	40.00	3.25	100	90	Vertical
4	138.8	57.43	-19.45	37.98	43.50	5.52	100	243	Vertical
5	190.1	52.29	-16.43	35.86	43.50	7.64	100	179	Vertical
6	308.2	47.54	-12.58	34.96	46.50	11.54	100	322	Vertical

Note:

- 1). Pre-scan all modes and recorded the worst case results in this report(#WostCaseSRD)
- 2). Margin=Limit-Result Level



Horizontal:

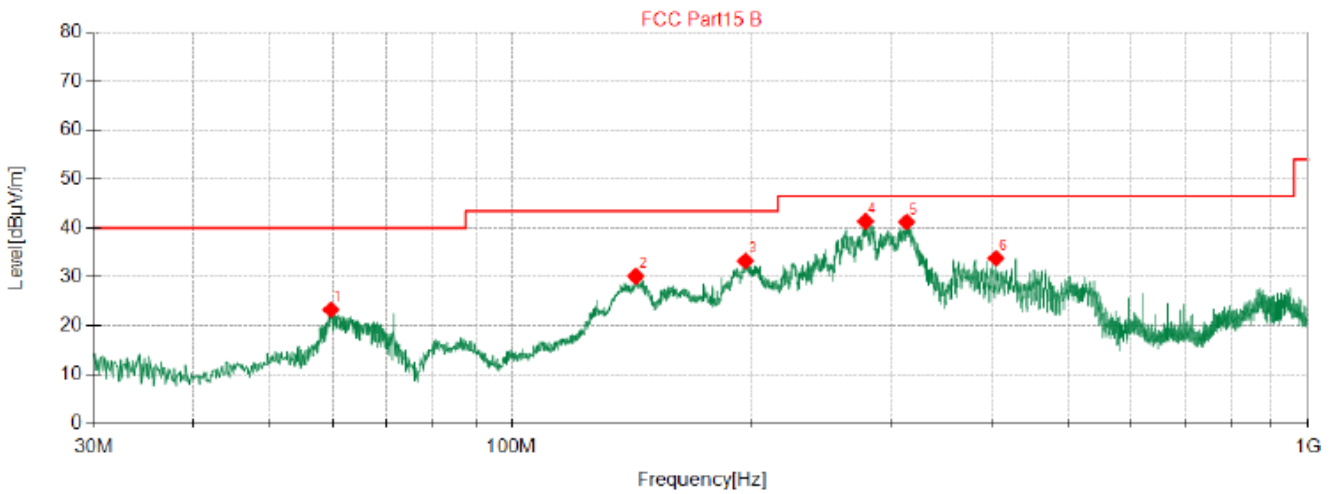

◆ QP Detector

Suspected Data List									
NO.	Freq. [MHz]	Reading [dBµV]	Factor [dB/m]	Level [dBµV/m]	Limit [dBµV/m]	Margin [dB]	Height [cm]	Angle [°]	Polarity
1	59.58	38.90	-15.59	23.31	40.00	16.69	100	16	Horizontal
2	143.1	49.52	-19.37	30.15	43.50	13.35	100	308	Horizontal
3	196.4	49.04	-15.79	33.25	43.50	10.25	100	276	Horizontal
4	278.0	54.66	-13.27	41.39	46.50	5.11	100	180	Horizontal
5	313.1	53.72	-12.45	41.27	46.50	5.23	100	270	Horizontal
6	405.6	43.73	-9.93	33.80	46.50	12.70	100	142	Horizontal

Note:

- 1). Pre-scan all modes and recorded the worst case results in this report(#WostCaseSRD)
- 2). Margin=Limit-Result Level



## 7 ANTENNA REQUIREMENT

### Standard Applicable

For intentional device, according to FCC 47 CFR Section 15.203, an intentional radiator shall be designed to ensure that no antenna other than that furnished by the responsible party shall be used with the device.

### Refer to statement below for compliance.

The manufacturer may design the unit so that the user can replace a broken antenna, but the use of a standard antenna jack or electrical connector is prohibited. Further, this requirement does not apply to intentional radiators that must be professionally installed.

### Antenna Connected Construction

The antenna used in this product is a Coil Antenna, The directional gains of antenna used for transmitting is 0dBi.

### ANTENNA

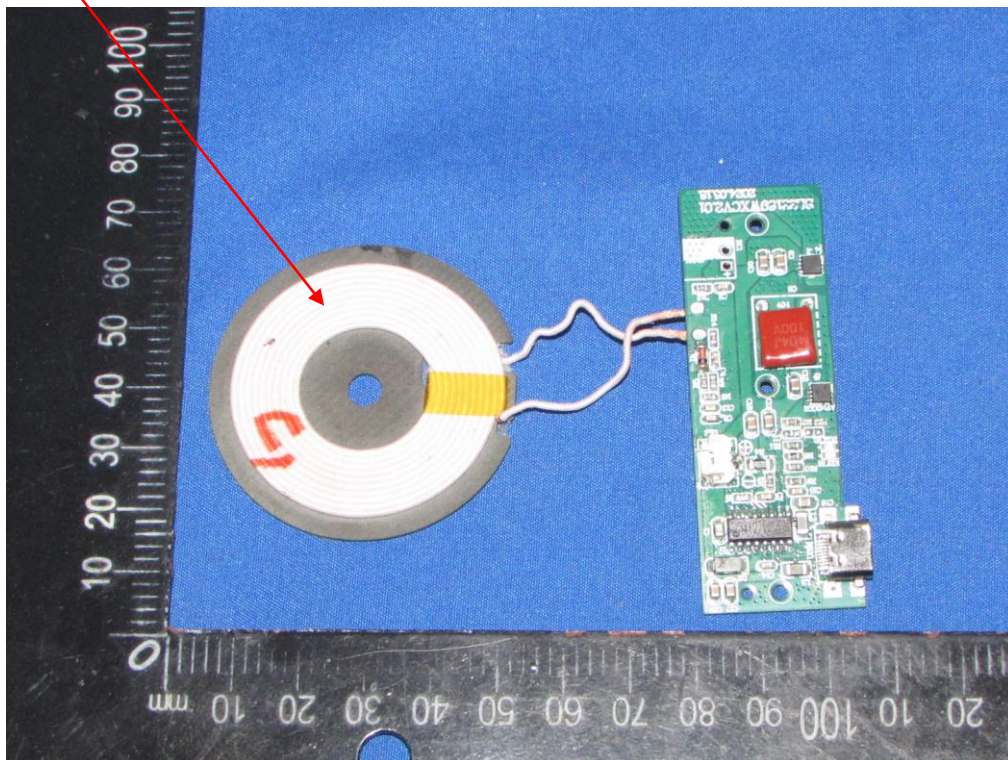



## **7. TEST SETUP Photographs of EUT**

Please refer to separated files for Test Setup Photos of the EUT.

## **8. Exterior Photographs of the EUT**

Please refer to separated files for External Photos of the EUT.

## **9. INTERIOR Photographs of the EUT**

Please refer to separated files for Internal Photos of the EUT.

-----THE END OF REPORT-----