

TEST REPORT

Applicant Name: Shenzhen Neutop Optoelectronics Co., Ltd
Address: 502, BLDG 4, Pingshan minQi Technology Park, No. 65 Lishan Road, Pingshan Community, Taoyuan Street, Nanshan District, Shenzhen China
Report Number: 2501U29284E-RF-00A
FCC ID: 2BEGB-A01M21

Test Standard (s)

FCC PART 15.247

Sample Description

Product Type: Projector
Model No.: A01M21
Multiple Model(s) No.: A**M21 ("**" = 01-99 , indicates for different market or business purposes), D004
Trade Mark: Aurzen
Date Received: 2025-06-06
Issue Date: 2025-07-25

Test Result:	Pass [▲]
--------------	-------------------

▲ In the configuration tested, the EUT complied with the standards above.

Prepared and Checked By:

Ekko Wu

Ekko Wu
RF Engineer

Approved By:

Nancy Wang

Nancy Wang
RF Supervisor

Note: The information marked * is provided by the applicant, the laboratory is not responsible for its authenticity and this information can affect the validity of the result in the test report. Customer model name, addresses, names, trademarks etc. are included.

This report cannot be reproduced except in full, without prior written approval of the Company. Unless otherwise stated the results shown in this test report refer only to the sample(s) tested. This report is valid only with a valid digital signature. The digital signature may be available only under the Adobe software above version 7.0.

This report must not be used by the customer to claim product certification, approval, or endorsement by NVLAP or any agency of the U.S. Government.

This report may contain data that are not covered by the NVLAP accreditation and are marked with an asterisk "▼".

Bay Area Compliance Laboratories Corp. (Shenzhen)

5F(B-West), 6F, 7F, the 3rd Phase of Wan Li Industrial Building D, Shihua Rd, FuTian Free Trade Zone, Shenzhen, China
Tel: +86-755-33320018 Fax: +86-755-33320008 www.baclcorp.com.cn

TABLE OF CONTENTS

DOCUMENT REVISION HISTORY	3
GENERAL INFORMATION	4
PRODUCT DESCRIPTION FOR EQUIPMENT UNDER TEST (EUT).....	4
OBJECTIVE	4
TEST METHODOLOGY.....	4
MEASUREMENT UNCERTAINTY	5
TEST FACILITY	5
SYSTEM TEST CONFIGURATION.....	6
SUMMARY OF TEST RESULTS	9
TEST EQUIPMENT LIST	10
REQUIREMENTS AND TEST PROCEDURES	11
AC LINE CONDUCTED EMISSIONS	11
RADIATED EMISSIONS	13
20 dB EMISSION BANDWIDTH.....	16
CHANNEL SEPARATION TEST	18
QUANTITY OF HOPPING CHANNEL TEST	19
TIME OF OCCUPANCY (DWELL TIME)	20
PEAK OUTPUT POWER MEASUREMENT	21
BAND EDGES.....	22
ANTENNA REQUIREMENT	23
TEST DATA AND RESULTS	24
AC LINE CONDUCTED EMISSIONS.....	24
RADIATED EMISSIONS	29
20 dB EMISSION BANDWIDTH.....	51
99% OCCUPIED BANDWIDTH	54
CHANNEL SEPARATION	57
NUMBER OF HOPPING FREQUENCY	59
MAXIMUM CONDUCTED OUTPUT POWER	61
100 KHZ BANDWIDTH OF FREQUENCY BAND EDGE.....	64
TIME OF OCCUPANCY (DWELL TIME).....	67
RF EXPOSURE EVALUATION	70
EUT PHOTOGRAPHS	72
TEST SETUP PHOTOGRAPHS	73

DOCUMENT REVISION HISTORY

Revision Number	Report Number	Description of Revision	Date of Revision
0	2501U29284E-RF-00A	Original Report	2025-07-25

GENERAL INFORMATION

Product Description for Equipment under Test (EUT)

Product	Projector
Tested Model	A01M21
Multiple Model(s)	A**M21 ("**"= 01-99 , indicates for different market or business purposes), D004
Frequency Range	2402~2480MHz
Transmit Peak Power	8.93dBm
Modulation Technique	Bluetooth: GFSK, $\pi/4$ -DQPSK, 8DPSK
Antenna Specification[#]	2.64dBi (provided by the applicant)
Voltage Range	DC 24V from adapter or DC 20V from USB Type-C Port
Sample serial number	348G-2 for Conducted and Radiated Emissions Test 348G-1 for RF Conducted Test (Assigned by BACL, Shenzhen)
Sample/EUT Status	Good condition
Adapter Information	Model: TEKA-EA2400375 Input: AC 100-240V~50/60Hz 2.0A MAX Output: DC 24.0V, 3.75A, 90.0W
Note: The Multiple models are electrically identical with the test model except for model number and sales channel. Please refer to the declaration letter [#] for more detail, which was provided by manufacturer.	

Objective

This test report is in accordance with Part 2-Subpart J, Part 15-Subparts A and C of the Federal Communication Commission rules.

The tests were performed in order to determine compliance with FCC Part 15, Subpart C, section 15.203, 15.207, 15.205, 15.209 and 15.247 rules.

Test Methodology

All measurements contained in this report were conducted with ANSI C63.10-2020, American National Standard of Procedures for Compliance Testing of Unlicensed Wireless Devices.

And KDB 558074 D01 15.247 Meas Guidance v05r02.

All emissions measurement was performed at Bay Area Compliance Laboratories Corp. (Shenzhen). The radiated testing was performed at an antenna-to-EUT distance of 3 meters.

Each test item follows test standards and with no deviation.

Measurement Uncertainty

Parameter		Uncertainty
Occupied Channel Bandwidth		109.2kHz(k=2, 95% level of confidence)
RF output power, conducted		0.86dB(k=2, 95% level of confidence)
Dwell Time		±1%(k=2, 95% level of confidence)
AC Power Lines Conducted Emissions	9kHz-150kHz	3.63dB(k=2, 95% level of confidence)
	150kHz-30MHz	3.66dB(k=2, 95% level of confidence)
Radiated Emissions	0.009MHz~30MHz	3.60dB(k=2, 95% level of confidence)
	30MHz~200MHz (Horizontal)	5.32dB(k=2, 95% level of confidence)
	30MHz~200MHz (Vertical)	5.43dB(k=2, 95% level of confidence)
	200MHz~1000MHz (Horizontal)	5.77dB(k=2, 95% level of confidence)
	200MHz~1000MHz (Vertical)	5.73dB(k=2, 95% level of confidence)
	1GHz - 6GHz	5.34dB(k=2, 95% level of confidence)
	6GHz - 18GHz	5.40dB(k=2, 95% level of confidence)
18GHz - 40GHz	5.64dB(k=2, 95% level of confidence)	
Temperature		±1°C
Humidity		±1%
Supply voltages		±0.4%

Note: The extended uncertainty given in this report is obtained by combining the standard uncertainty times the coverage factor K with the 95% confidence interval. Otherwise required by the applicant or Product Regulations, Decision Rule in this report did not consider the uncertainty.

Test Facility

The Test site used by Bay Area Compliance Laboratories Corp. (Shenzhen) to collect test data is located on the 5F(B-West) , 6F, 7F, the 3rd Phase of Wan Li Industrial Building D, Shihua Rd, FuTian Free Trade Zone, Shenzhen, China.

The lab has been recognized as the FCC accredited lab under the KDB 974614 D01 and is listed in the FCC Public Access Link (PAL) database, FCC Registration No. : 715558, the FCC Designation No. : CN5045.

SYSTEM TEST CONFIGURATION

Description of Test Configuration

The system was configured for testing in an engineering mode.

Channel	Frequency (MHz)	Channel	Frequency (MHz)
0	2402	40	2442
1	2403	41	2443
2	2404	42	2444
...
...
36	2438	75	2477
37	2439	76	2478
38	2440	77	2479
39	2441	78	2480

EUT was tested with Channel 0, 39 and 78.

EUT Exercise Software

Exercise Software#	CMD
Power Level#	Default

Special Accessories

No special accessory.

Equipment Modifications

No modification was made to the EUT tested.

Support Equipment List and Details

Manufacturer	Description	Model	Serial Number
GREATWALL	PC	NF50AL	Unknown
Redmi	Earphone	Unknown	Unknown
snom	Earphone	A100D	100D4342013597
SUOSHI	USB disk	S1256J	Unknown
Huntkey	Adapter	HKA06520033-016	Unknown

External I/O Cable

Cable Description	Length (m)	From Port	To
Unshielded Un-Detachable AC cable	1.2	Receptacle	AC Mains/LISN
Unshielded Detachable AC cable	0.5	Receptacle	Adapter
Unshielded Detachable AC cable	0.8	Receptacle	Adapter
Unshielded Un-detachable DC cable	1.0	Adapter	EUT
Unshielded Un-detachable Audio cable	1.5	EUT	Earphone
Shielded Detachable HDMI cable	2.0	EUT	PC

Block Diagram of Test Setup

For Conducted Emissions:

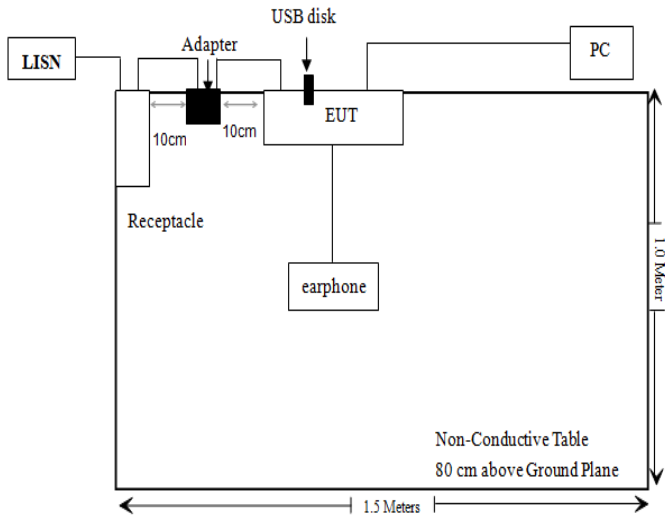

For Radiated Emissions below 1GHz:

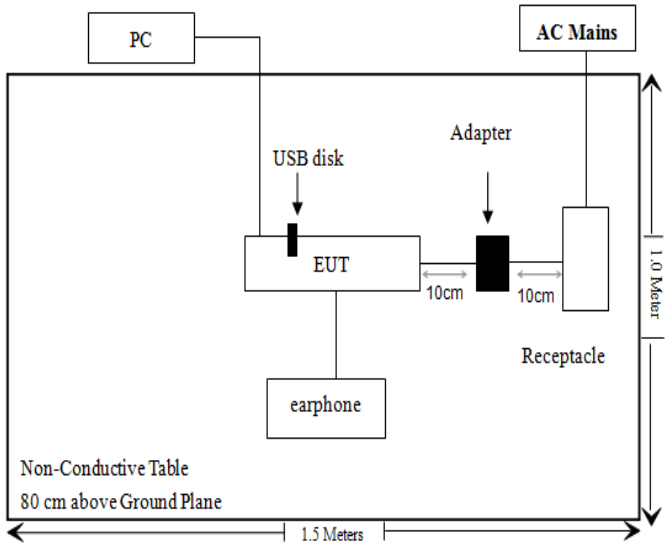

For Radiated Emissions above 1GHz:

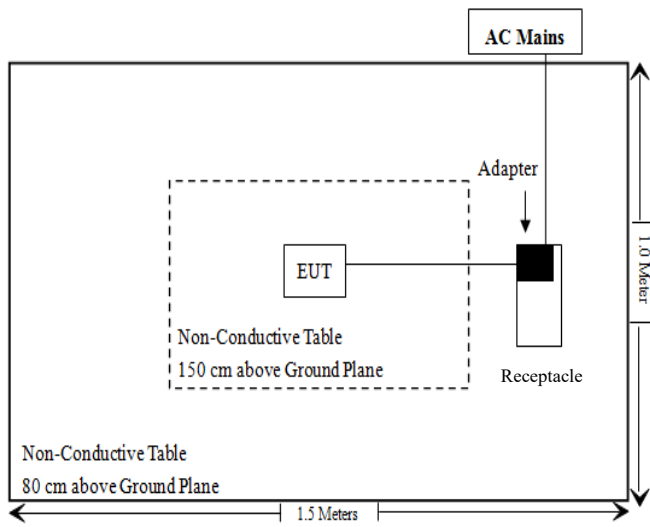

SUMMARY OF TEST RESULTS

Rules	Description of Test	Result
§1.1310 & §2.1091	Maximum Permissible Exposure (MPE)	Compliant
FCC §15.203	Antenna Requirement	Compliant
FCC §15.207(a)	AC Line Conducted Emissions	Compliant
FCC §15.205, §15.209, §15.247(d)	Radiated Emissions	Compliant
FCC §15.247(a)(1)	20 dB Emission Bandwidth	Compliant
FCC §15.247(a)(1)	Channel Separation Test	Compliant
FCC §15.247(a)(1)(iii)	Time of Occupancy (Dwell Time)	Compliant
FCC §15.247(a)(1)(iii)	Quantity of hopping channel Test	Compliant
FCC §15.247(b)(1)	Peak Output Power Measurement	Compliant
FCC §15.247(d)	Band edges	Compliant

TEST EQUIPMENT LIST

Manufacturer	Description	Model	Serial Number	Calibration Date	Calibration Due Date
Conducted Emission Test					
Rohde & Schwarz	EMI Test Receiver	ESCI	101120	2024/12/04	2025/12/03
Rohde & Schwarz	LISN	ENV216	101613	2024/12/04	2025/12/03
Rohde & Schwarz	Transient Limiter	ESH3Z2	DE25985	2025/04/29	2026/04/28
Unknown	CE Cable	Unknown	UF A210B-1-0720-504504	2025/04/29	2026/04/28
Audix	EMI Test software	E3	191218(V9)	NCR	NCR
Radiated Emission Test					
Rohde & Schwarz	EMI Test Receiver	ESR3	102455	2024/12/04	2025/12/03
Sonoma instrument	Pre-amplifier	310N	186238	2025/04/29	2026/04/28
Sunol Sciences	Broadband Antenna	JB1	A040904-1	2023/07/20	2026/07/19
Unknown	Cable	Chamber Cable 1	F-03-EM236	2025/04/29	2026/04/28
Unknown	Cable	XH500C	J-10M-A	2025/04/29	2026/04/28
BACL	Active Loop Antenna	1313-1A	4031911	2024/05/14	2027/05/13
Unknown	Cable	2Y194	0735	2024/12/04	2025/12/03
unknown	Cable	PNG214	1354	2024/12/04	2025/12/03
Audix	EMI Test software	E3	19821b(V9)	NCR	NCR
Rohde&Schwarz	Spectrum Analyzer	FSV40	101605	2025/03/26	2026/03/25
A.H.System	Preamplifier	PAM-0118P	489	2024/11/15	2025/11/14
Schwarzbeck	Horn Antenna	BBHA9120D(1201)	1143	2023/07/26	2026/07/25
Unknown	RF Cable	KMSE	0735	2024/12/06	2025/12/05
Unknown	RF Cable	UFA147	219661	2024/12/06	2025/12/05
Unknown	RF Cable	XH750A-N	J-10M	2024/12/06	2025/12/05
JD	Filter Switch Unit	DT7220FSU	DS79906	2024/09/09	2025/09/08
JD	Multiplex Switch Test Control Set	DT7220SCU	DS79903	2024/09/09	2025/09/08
A.H.System	Pre-amplifier	PAM-1840VH	190	2025/04/29	2026/04/28
Electro-Mechanics Co	Horn Antenna	3116	9510-2270	2023/09/18	2026/09/17
UTIFLEX	RF Cable	NO. 13	232308-001	2024/12/18	2025/12/17
Audix	EMI Test software	E3	191218(V9)	NCR	NCR
RF Conducted Test					
Rohde&Schwarz	Spectrum Analyzer	FSV40-N	102259	2024/12/04	2025/12/03
Unknown	10dB Attenuator	Unknown	F-03-EM065	2025/06/26	2026/06/25

* **Statement of Traceability:** Bay Area Compliance Laboratories Corp. (Shenzhen) attests that all calibrations have been performed in accordance to requirements that traceable to National Primary Standards and International System of Units (SI).

REQUIREMENTS AND TEST PROCEDURES

AC Line Conducted Emissions

Applicable Standard

FCC §15.207(a)

EUT Setup

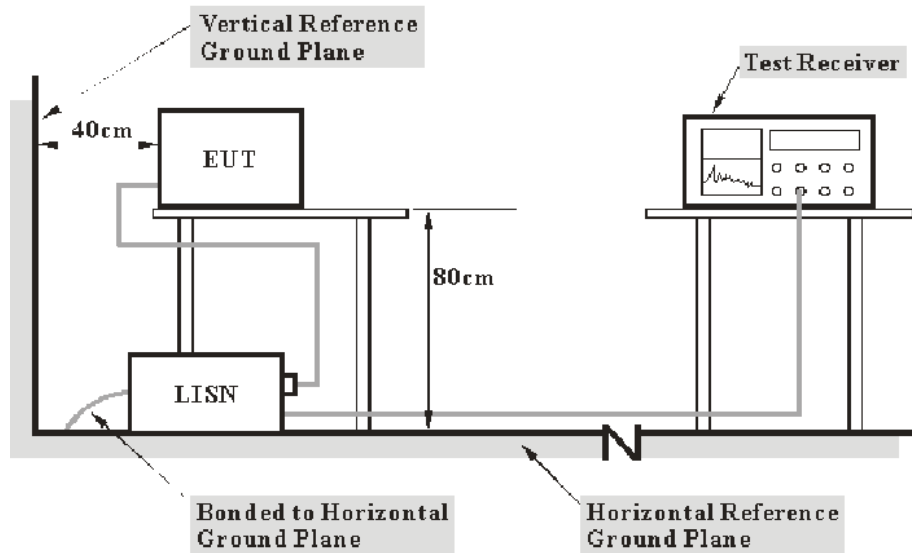

- Note: 1. Support units were connected to second LISN.
 2. Both of LISNs (AMN) 80 cm from EUT and at the least 80 cm from other units and other metal planes support units.

The measurement procedure of EUT setup is according with ANSI C63.10-2020. The related limit was specified in FCC Part 15.207.

The spacing between the peripherals was 10 cm.

EMI Test Receiver Setup

The EMI test receiver was set to investigate the spectrum from 150 kHz to 30 MHz.

During the conducted emission test, the EMI test receiver was set with the following configurations:

Frequency Range	RBW
150 kHz – 30 MHz	9 kHz

Test Procedure

Maximizing procedure was performed on the six (6) highest emissions of the EUT.

All final data was recorded in the Quasi-peak and average detection mode.

Factor & Over Limit Calculation

The factor is calculated by adding LISN VDF (Voltage Division Factor) and Cable Loss. The basic equation is as follows:

$$\text{Factor} = \text{LISN VDF} + \text{Cable Loss}$$

The “**Over limit**” column of the following data tables indicates the degree of compliance with the applicable limit. For example, an Over limit of -7 dB means the emission is 7 dB below the limit. The equation for calculation is as follows:

$$\begin{aligned}\text{Over Limit} &= \text{Level} - \text{Limit} \\ \text{Level} &= \text{Read Level} + \text{Factor}\end{aligned}$$

Note: The term "cable loss" refers to the combination of a cable and a 10dB transient limiter (attenuator).

Radiated Emissions

Applicable Standard

FCC §15.205; §15.209; §15.247(d)

EUT Setup

9 kHz-30MHz:

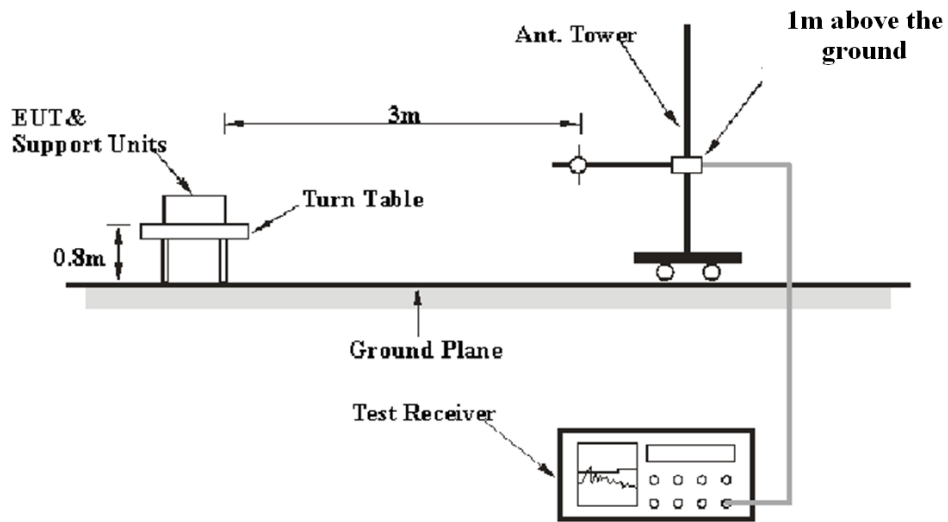

30MHz-1GHz:

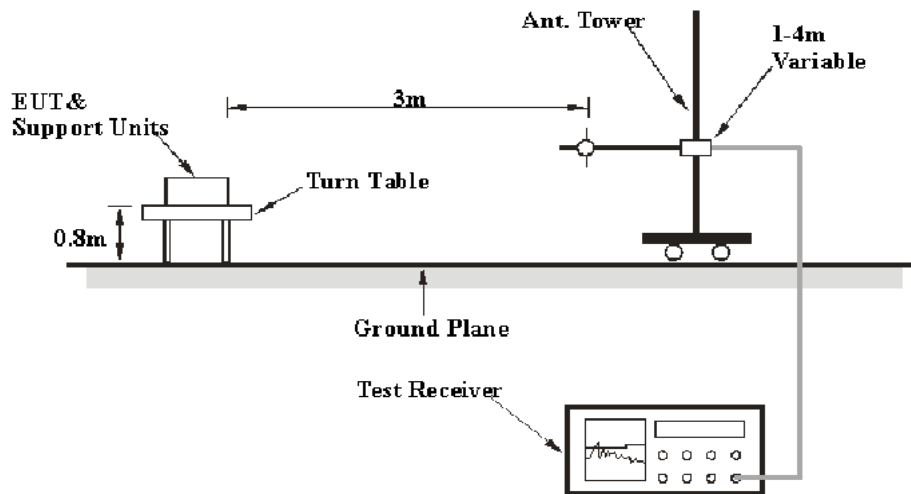

Above 1GHz:

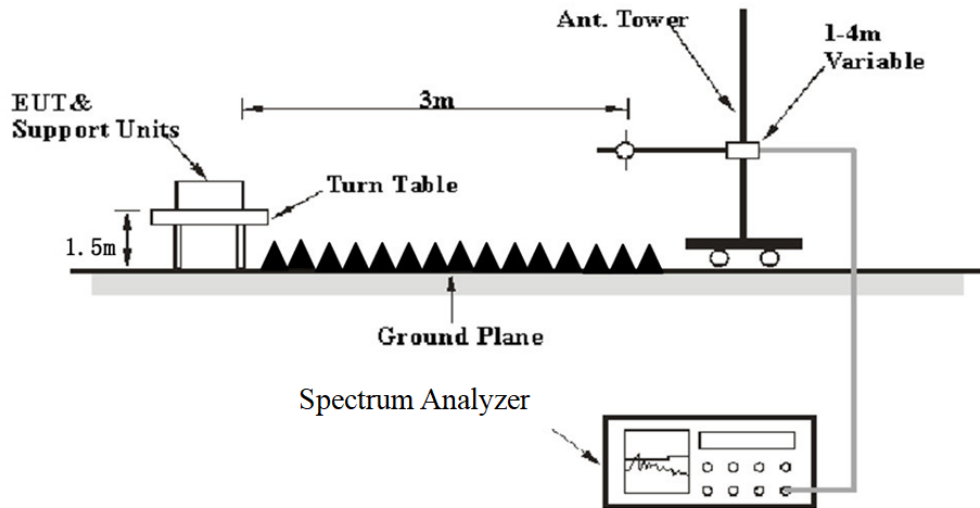

The radiated emission tests were performed in the 3 meters, using the setup accordance with the ANSI C63.10-2020. The specification used was the FCC 15.209 and FCC 15.247 limits.

EMI Test Receiver & Spectrum Analyzer Setup

The EMI test receiver & Spectrum Analyzer Setup were set with the following configurations:

Frequency Range	RBW	Video B/W	IF B/W	Measurement	Detector
9 kHz – 150 kHz	/	/	200 Hz	QP	QP
	300 Hz	1 kHz	/	PK	Peak
150 kHz – 30 MHz	/	/	9 kHz	QP	QP
	10 kHz	30 kHz	/	PK	Peak
30 MHz – 1000 MHz	/	/	120 kHz	QP	QP
	100 kHz	300 kHz	/	PK	Peak
Above 1 GHz	Harmonics				
	1MHz	3 MHz	/	PK	Peak
	Average Emission Level=Peak Emission Level+20*log(Duty cycle)				
	Band Edge & Other Emissions				
	1MHz	3 MHz	/	PK	Peak
	1MHz	≥10 Hz	/	Average	Peak

For Duty cycle measurement:

Use the duty cycle factor correction factor method per 15.35(c).

Duty cycle=On time/100milliseconds, On time= $N1*L1+N2*L2+...Nn-1*Ln-1+Nn*Ln$,

Where N1 is number of type 1 pulses, L1 is length of type 1 pulse, etc.

Test Procedure

Maximizing procedure was performed on the highest emissions to ensure that the EUT complied with all installation combinations.

All final data was recorded in Quasi-peak detection mode except for the frequency bands 9–90 kHz, 110–490 kHz and above 1000 MHz, average detection modes for frequency bands 9–90 kHz and 110–490 kHz, peak and average detection modes for frequencies above 1 GHz.

For 9 kHz-30MHz, the report shall list the six emissions with the smallest margin relative to the limit, for each of the three antenna orientations (parallel, perpendicular, and ground-parallel) unless the margin is greater than 20 dB.

If the maximized peak measured value complies with under the QP/Average limit more than 6dB, then it is unnecessary to perform an QP/Average measurement.

All emissions under the average limit and under the noise floor have not recorded in the report.

Factor & Over Limit/Margin Calculation

The **Factor** is calculated by adding the Antenna Factor and Cable Loss, and subtracting the Amplifier Gain. The basic equation is as follows:

$$\text{Factor} = \text{Antenna Factor} + \text{Cable Loss} - \text{Amplifier Gain}$$

The “**Over Limit/Margin**” column of the following data tables indicates the degree of compliance with the applicable limit. For example, an Over Limit/margin of -7dB means the emission is 7dB below the limit. The equation for calculation is as follows:

$$\begin{aligned} \text{Over Limit/Margin} &= \text{Level/Corrected Amplitude} - \text{Limit} \\ \text{Level / Corrected Amplitude} &= \text{Read Level} + \text{Factor} \end{aligned}$$

20 dB Emission Bandwidth

Applicable Standard

Alternatively, frequency hopping systems operating in the 2400–2483.5 MHz band may have hopping channel carrier frequencies that are separated by 25 kHz or two-thirds of the 20 dB bandwidth of the hopping channel, whichever is greater, provided the systems operate with an output power no greater than 125 mW.

Test Procedure

Test Method: ANSI C63.10-2020 Clause 6.9.2

- a) The spectrum analyzer center frequency is set to the nominal EUT channel center frequency. The span range for the EMI receiver or spectrum analyzer shall be between two times and five times the OBW.
- b) The nominal IF filter bandwidth (3 dB RBW) shall be in the range of 1% to 5% of the OBW and video bandwidth (VBW) shall be at least three times RBW, unless otherwise specified by the applicable requirement.
- c) Set the reference level of the instrument as required, keeping the signal from exceeding the maximum input mixer level for linear operation. In general, the peak of the spectral envelope shall be more than $[10 \log (\text{OBW}/\text{RBW})]$ below the reference level. Specific guidance is given in 4.1.6.2.
- d) Steps a) through c) might require iteration to adjust within the specified tolerances.
- e) The dynamic range of the instrument at the selected RBW shall be more than 10 dB below the target “–xx dB down” requirement; that is, if the requirement calls for measuring the –20 dB OBW, the instrument noise floor at the selected RBW shall be at least 30 dB below the reference value.
- f) Set detection mode to peak and trace mode to max-hold.
- g) Determine the reference value: Set the EUT to transmit an unmodulated carrier or modulated signal, as applicable. Allow the trace to stabilize. Set the spectrum analyzer marker to the highest level of the displayed trace (this is the reference value).
- h) Determine the “–xx dB down amplitude” using $[(\text{reference value}) - \text{xx}]$. Alternatively, this calculation may be made by using the marker-delta function of the instrument.
- i) If the reference value is determined by an unmodulated carrier, then turn the EUT modulation ON, and either clear the existing trace or start a new trace on the spectrum analyzer and allow the new trace to stabilize. Otherwise, the trace from step g) shall be used for step j).

j) Place two markers, one at the lowest frequency and the other at the highest frequency of the envelope of the spectral display, such that each marker is at or slightly below the “-xx dB down amplitude” determined in step h). If a marker is below this “-xx dB down amplitude” value, then it shall be as close as possible to this value. The dBc bandwidth is the frequency difference between the two markers. Alternatively, set a marker at the lowest frequency of the envelope of the spectral display, such that the marker is at or slightly below the “-xx dB down amplitude” determined in step h). Reset the marker-delta function and move the marker to the other side of the emission until the delta marker amplitude is at the same level as the reference marker amplitude. The marker-delta frequency reading at this point is the specified emission bandwidth.

k) The dBc bandwidth shall be reported by providing spectral plot(s) of the measuring instrument display; the plot axes and the scale units per division shall be clearly labeled. Tabular data may be reported in addition to the plot(s).

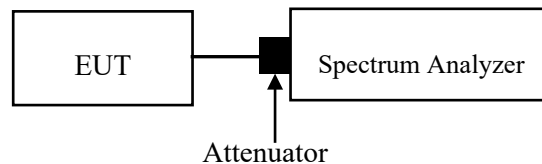

Channel Separation Test

Applicable Standard

Frequency hopping systems shall have hopping channel carrier frequencies separated by a minimum of 25 kHz or the 20 dB bandwidth of the hopping channel, whichever is greater. Alternatively, frequency hopping systems operating in the 2400-2483.5 MHz band may have hopping channel carrier frequencies that are separated by 25 kHz or two-thirds of the 20 dB bandwidth of the hopping channel, whichever is greater provided the systems operate with an output power no greater than 125 mW. The system shall hop to channel frequencies that are selected at the system hopping rate from a pseudo randomly ordered list of hopping frequencies. Each frequency must be used equally on the average by each transmitter. The system receivers shall have input bandwidths that match the hopping channel bandwidths of their corresponding transmitters and shall shift frequencies in synchronization with the transmitted signals.

Test Procedure

Test Method: ANSI C63.10-2020 Clause 7.8.2

The EUT shall have its hopping function enabled. Use the following spectrum analyzer settings:

- a) Span: Wide enough to capture the peaks of two adjacent channels.
- b) RBW: Start with the RBW set to approximately 30% of the channel spacing; adjust as necessary to best identify the center of each individual channel.
- c) Video (or average) bandwidth (VBW) \geq RBW.
- d) Sweep: No faster than coupled (auto) time.
- e) Detector function: Peak.
- f) Trace: Max-hold.
- g) Allow the trace to stabilize.

Use the marker-delta function to determine the separation between the peaks of the adjacent channels. Compliance of an EUT with the appropriate regulatory limit shall be determined. A spectral plot of the data shall be included in the test report.

Where the device shares the same channel plan (carrier frequencies and number of channels) across multiple data rates or modulation schemes then the carrier separation need only be measured for one of those modulation schemes or data rates.

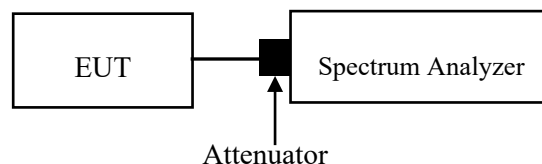

Note: The limit is $2/3 * 20$ dB bandwidth

Quantity of Hopping Channel Test

Applicable Standard

Frequency hopping systems in the 2400–2483.5 MHz band shall use at least 15 channels. The average time of occupancy on any channel shall not be greater than 0.4 seconds within a period of 0.4 seconds multiplied by the number of hopping channels employed. Frequency hopping systems may avoid or suppress transmissions on a particular hopping frequency provided that a minimum of 15 channels are used.

Test Procedure

Test Method: ANSI C63.10-2020 Clause 7.8.3

The EUT shall have its hopping function enabled. Use the following spectrum analyzer settings:

- a) Span: The frequency band of operation. Depending on the number of channels the device supports, it could be necessary to divide the frequency range of operation across multiple spans, to allow the individual channels to be clearly seen.
- b) RBW: To identify clearly the individual channels, set the RBW to less than 30% of the channel spacing or the 20 dB bandwidth, whichever is smaller.
- c) VBW \geq RBW.
- d) Sweep: No faster than coupled (auto) time.
- e) Detector function: Peak.
- f) Trace: Max-hold.
- g) Allow the trace to stabilize.

It might prove necessary to break the span up into subranges to show clearly all of the hopping frequencies.

Compliance of an EUT with the appropriate regulatory limit shall be determined for the number of hopping channels. A spectral plot of the data shall be included in the test report.

Where the device shares the same channel plan (carrier frequencies and number of channels) across multiple data rates or modulation schemes then the number of channels need only be measured for one of those modulation schemes or data rates.

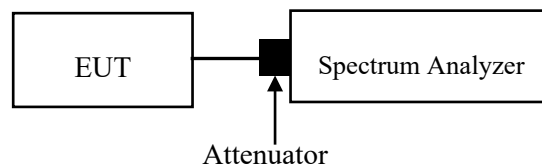

Time of Occupancy (Dwell Time)

Applicable Standard

Frequency hopping systems in the 2400-2483.5 MHz shall use at least 15 channels. The average time of occupancy on any channel shall not be greater than 0.4 seconds within a period of 0.4 seconds multiplied by the number of hopping channels employed. Frequency hopping systems may avoid or suppress transmissions on a particular hopping frequency provided that a minimum of 15 channels are used.

Test Procedure

Test Method: ANSI C63.10-2020 Clause 7.8.4

Use the following spectrum analyzer settings to determine the dwell time per hop:

- a) Span: Zero span, centered on a hopping channel.
- b) RBW shall be \leq channel spacing and where possible RBW should be set $\gg 1 / T$, where T is the expected transmission time per hop.
- c) Sweep time: Set so that the start of the first transmission and end of the last transmission for the hop are clearly captured. Setting the sweep time to be slightly longer than the hopping period per channel (hopping period = $1/\text{hopping rate}$) should achieve this.
- d) Use a video trigger, where possible with a trigger delay, so that the start of the transmission is clearly observed. The trigger level might need adjustment to reduce the chance of triggering when the system hops on an adjacent channel.
- e) Detector function: Peak.
- f) Trace: Clear-write, single sweep.
- g) Place markers at the start of the first transmission on the channel and at the end of the last transmission. The dwell time per hop is the time between these two markers.

To determine the number of hops on a channel in the regulatory observation period repeat the measurement using a longer sweep time. When the device uses a single hopping sequence the period of measurement should be sufficient to capture at least 2 hops. When the device uses a dynamic hopping sequence, or the sequence varies, the period of measurement may need to capture multiple hops to better determine the average time of occupancy. Count the number of hops on the channel across the sweep time.

The average number of hops on the same channel within the regulatory observation period is calculated from the number of hops on the channel divided by the spectrum analyzer sweep time multiplied by the regulatory observation period. For example, if three hops are counted with an analyzer sweep time of 500 ms and the regulatory observation period is 10 s, then the number of hops in that ten seconds is $3 / 0.5 \times 10$, or 60 hops.

The average time of occupancy is calculated by multiplying the dwell time per hop by the number of hops in the observation period.

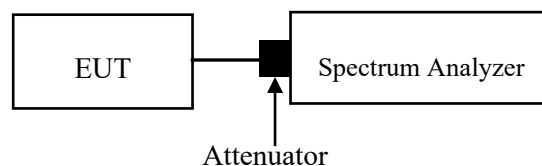

Peak Output Power Measurement

Applicable Standard

According to §15.247(b) (1), for frequency hopping systems operating in the 2400–2483.5 MHz band employing at least 75 non-overlapping hopping channels, and all frequency hopping systems in the 5725–5850 MHz band: 1 watt. And for all other frequency hopping systems in the 2400–2483.5 MHz band: 0.125 watts.

Test Procedure

Test Method: ANSI C63.10-2020 Clause 7.8.5

This is an RF-conducted test to evaluate maximum peak output power. Use a direct connection between the antenna port of the unlicensed wireless device and the spectrum analyzer, through suitable attenuation. Frequency hopping shall be disabled for this test. Use the following spectrum analyzer settings:

- a) Span: Approximately five times the 20 dB bandwidth, centered on a hopping channel.
- b) RBW > 20 dB bandwidth of the emission being measured.
- c) VBW \geq RBW.
- d) Sweep: No faster than coupled (auto) time.
- e) Detector function: Peak.
- f) Trace: Max-hold.
- g) Allow trace to stabilize.
- h) Use the marker-to-peak function to set the marker to the peak of the emission.
- i) The indicated level is the peak output power, after any corrections for external attenuators and cables.
- j) A spectral plot of the test results and setup description shall be included in the test report.

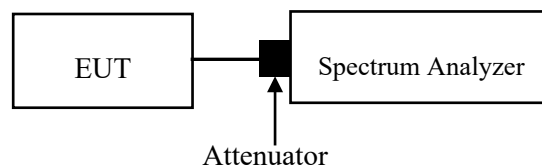

Note: A short RF cable with low cable loss connected to the EUT antenna port, which was provided by client or lab, the cable loss was added with offset into test equipment, the total offset consists of attenuator and/or RF cable loss

Band Edges

Applicable Standard

In any 100 kHz bandwidth outside the frequency band in which the spread spectrum or digitally modulated intentional radiator is operating, the radio frequency power that is produced by the intentional radiator shall be at least 20 dB below that in the 100 kHz bandwidth within the band that contains the highest level of the desired power, based on either an RF conducted or a radiated measurement, provided the transmitter demonstrates compliance with the peak conducted power limits. If the transmitter complies with the conducted power limits based on the use of RMS averaging over a time interval, as permitted under paragraph (b)(3) of this section, the attenuation required under this paragraph shall be 30 dB instead of 20 dB. Attenuation below the general limits specified in §15.209(a) is not required. In addition, radiated emissions which fall in the restricted bands, as defined in §15.205(a), must also comply with the radiated emission limits specified in §15.209(a) (see §15.205(c)).

Test Procedure

Test Method: ANSI C63.10-2020 Clause 7.8.7.2 & Clause 6.10

- 1) Span: Wide enough to capture the peak level of the emission operating on the channel closest to the band-edge, as well as any modulation products that fall outside of the authorized band of operation.
- 2) Reference level: As required to keep the signal from exceeding the maximum instrument input mixer level for linear operation. In general, the peak of the spectral envelope shall be more than $[10 \log (\text{OBW}/\text{RBW})]$ below the reference level. Specific guidance is given in 4.1.6.2.
- 3) Attenuation: Auto (at least 10 dB preferred).
- 4) Sweep time: No faster than coupled (auto) time.
- 5) Resolution bandwidth: 100 kHz.
- 6) Video bandwidth: 300 kHz.
- 7) Detector: Peak.
- 8) Trace: Max-hold.

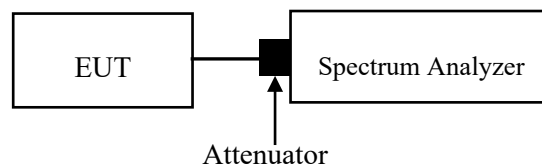

ANTENNA REQUIREMENT

Applicable Standard

According to FCC § 15.203, an intentional radiator shall be designed to ensure that no antenna other than that furnished by the responsible party shall be used with the device. The use of a permanently attached antenna or of an antenna that uses a unique coupling to the intentional radiator shall be considered sufficient to comply with the provisions of this Section. The manufacturer may design the unit so that a broken antenna can be replaced by the user, but the use of a standard antenna jack or electrical connector is prohibited.

Further, this requirement does not apply to intentional radiators that must be professionally installed, such as perimeter protection systems and some field disturbance sensors, or to other intentional radiators which, in accordance with § 15.31(d), must be measured at the installation site. However, the installer shall be responsible for ensuring that the proper antenna is employed so that the limits in this part are not exceeded.

Antenna Connector Construction

The EUT has an internal antenna arrangement, which was permanently attached, the antenna gain[#] is 2.64dBi, fulfill the requirement of this section. Please refer to the EUT photos.

Result: Compliant

TEST DATA AND RESULTS

AC Line Conducted Emissions

Environmental Conditions

Temperature (°C)	25.4	Relative Humidity (%)	67
ATM Pressure (kPa)	100	Test engineer	Macy.shi
Test date	2025.7.4		
EUT operation mode	Transmitting (Maximum output power mode, EDR (8DPSK) Low Channel)		

AC 120V 60 Hz, Line USB Type-C Port

Date: 2025-07-04

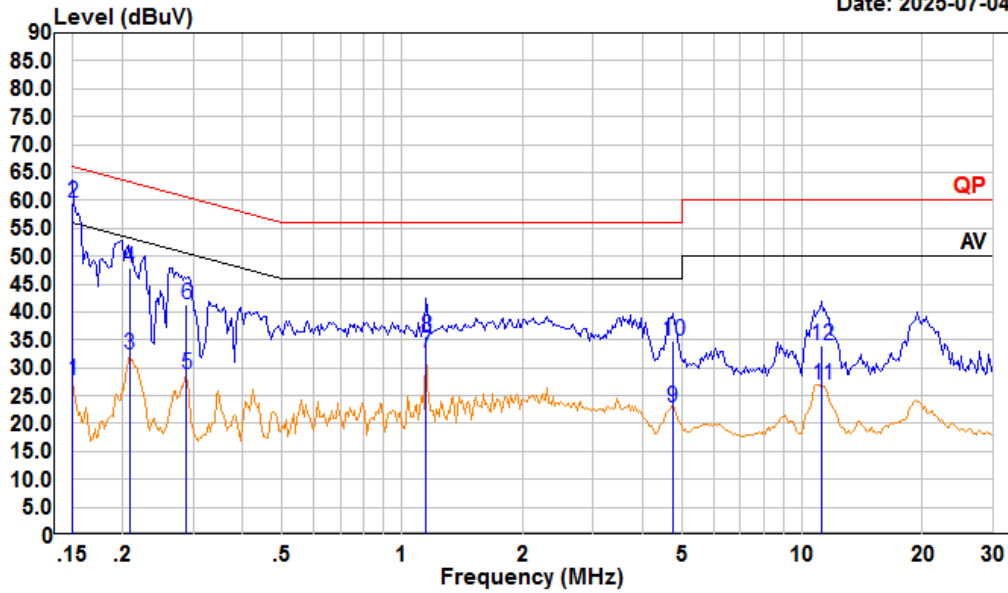

Trace: 1

Condition: Line

Project : 2501U29284E-RF

tester : Macy.shi Note:BT Transmitting

Setting : RBW:9kHz

	Read Freq	Read Level	LISN Level	LISN Factor	Cable Loss	Limit Line	Over Limit	Remark
	MHz	dBuV	dBuV	dB	dB	dBuV	dB	
1	0.150	7.10	27.66	10.40	10.16	56.00	-28.34	Average
2	0.150	39.00	59.56	10.40	10.16	66.00	-6.44	QP
3	0.208	11.39	32.27	10.69	10.19	53.28	-21.01	Average
4	0.208	26.90	47.78	10.69	10.19	63.28	-15.50	QP
5	0.289	7.95	28.76	10.62	10.19	50.55	-21.79	Average
6	0.289	20.60	41.41	10.62	10.19	60.55	-19.14	QP
7	1.147	11.75	32.63	10.70	10.18	46.00	-13.37	Average
8	1.147	14.70	35.58	10.70	10.18	56.00	-20.42	QP
9	4.746	1.80	22.88	10.81	10.27	46.00	-23.12	Average
10	4.746	13.80	34.88	10.81	10.27	56.00	-21.12	QP
11	11.198	6.50	27.06	10.30	10.26	50.00	-22.94	Average
12	11.198	13.40	33.96	10.30	10.26	60.00	-26.04	QP

AC 120V 60 Hz, Neutral_ USB Type-C Port

Date: 2025-07-04

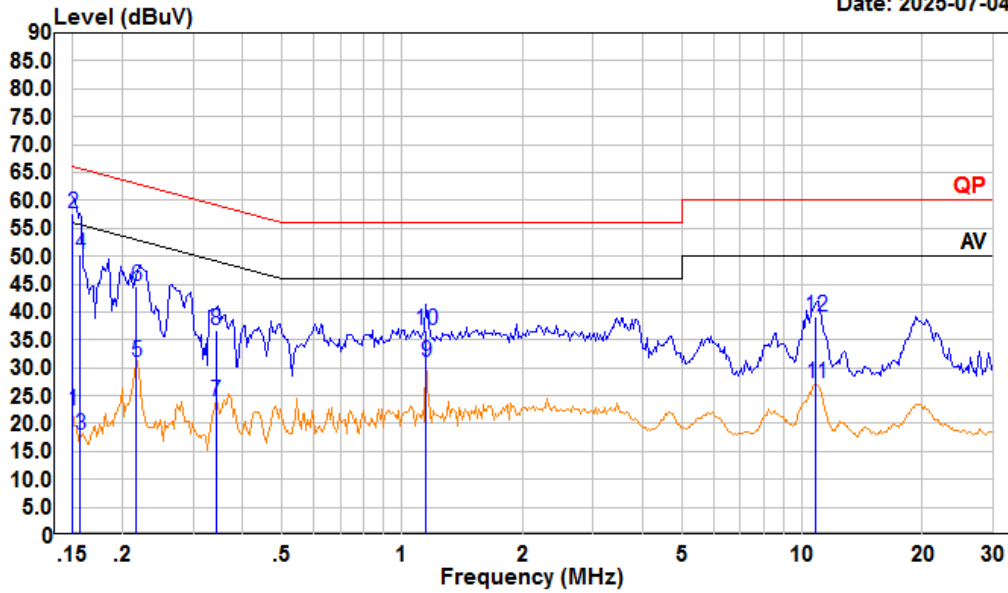

Trace: 1

Condition: Neutral

Project : 2501U29284E-RF

tester : Macy.shi Note:BT Transmitting

Setting : RBW:9kHz

	Read Freq	Read Level	LISN Level	LISN Factor	Cable Loss	Limit Line	Over Limit	Remark
	MHz	dBuV	dBuV	dB	dB	dBuV	dB	
1	0.150	1.70	22.26	10.40	10.16	56.00	-33.74	Average
2	0.150	37.00	57.56	10.40	10.16	66.00	-8.44	QP
3	0.156	-2.70	17.93	10.46	10.17	55.65	-37.72	Average
4	0.156	29.60	50.23	10.46	10.17	65.65	-15.42	QP
5	0.217	10.11	31.07	10.77	10.19	52.93	-21.86	Average
6	0.217	23.71	44.67	10.77	10.19	62.93	-18.26	QP
7	0.343	3.21	24.01	10.62	10.18	49.13	-25.12	Average
8	0.343	16.01	36.81	10.62	10.18	59.13	-22.32	QP
9	1.147	10.00	30.96	10.78	10.18	46.00	-15.04	Average
10	1.147	15.70	36.66	10.78	10.18	56.00	-19.34	QP
11	10.847	6.40	27.12	10.46	10.26	50.00	-22.88	Average
12	10.847	18.40	39.12	10.46	10.26	60.00	-20.88	QP

AC 120V 60 Hz, Line_Adapter

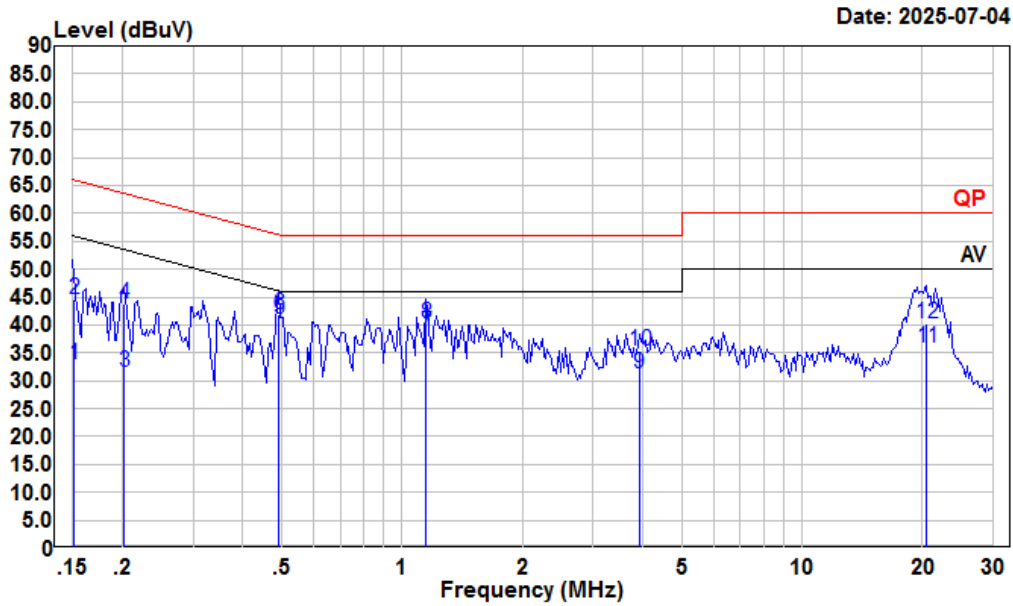

Date: 2025-07-04

Condition: Line
 Project : 2501U29284E-RF
 tester : Macy.shi Note:BT Transmitting
 Setting : RBW:9kHz

	Read Freq	Read Level	LISN Level	LISN Factor	Cable Loss	Limit Line	Over Limit	Remark
	MHz	dBuV	dBuV	dB	dB	dBuV	dB	
1	0.152	12.37	32.94	10.41	10.16	55.91	-22.97	Average
2	0.152	24.12	44.69	10.41	10.16	65.91	-21.22	QP
3	0.202	10.59	31.48	10.70	10.19	53.54	-22.06	Average
4	0.202	22.87	43.76	10.70	10.19	63.54	-19.78	QP
5	0.491	20.45	41.13	10.50	10.18	46.14	-5.01	Average
6	0.491	21.30	41.98	10.50	10.18	56.14	-14.16	QP
7	1.147	17.67	38.55	10.70	10.18	46.00	-7.45	Average
8	1.147	19.45	40.33	10.70	10.18	56.00	-15.67	QP
9	3.922	10.07	31.22	10.91	10.24	46.00	-14.78	Average
10	3.922	14.08	35.23	10.91	10.24	56.00	-20.77	QP
11	20.486	14.57	35.79	10.97	10.25	50.00	-14.21	Average
12	20.486	19.05	40.27	10.97	10.25	60.00	-19.73	QP

AC 120V 60 Hz, Neutral_Adapter

Date: 2025-07-04

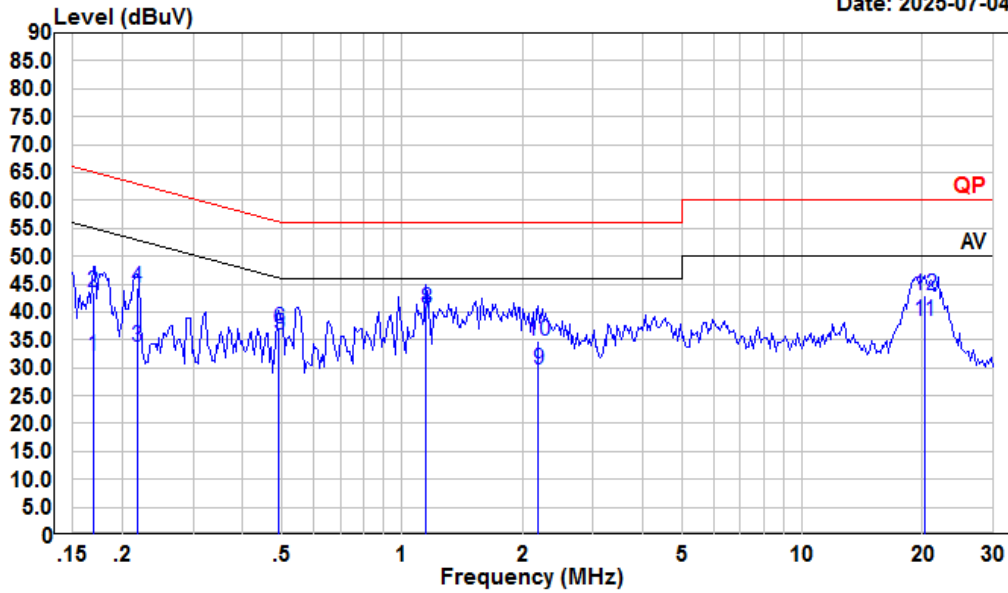

Condition: Neutral
 Project : 2501U29284E-RF
 tester : Macy.shi Note:BT Transmitting
 Setting : RBW:9kHz

	Read Freq	Read Level	LISN Level	LISN Factor	Cable Loss	Limit Line	Over Limit	Remark
	MHz	dBuV	dB	dB	dB	dBuV	dB	
1	0.169	11.45	32.20	10.56	10.19	55.03	-22.83	Average
2	0.169	22.69	43.44	10.56	10.19	65.03	-21.59	QP
3	0.217	12.70	33.66	10.77	10.19	52.92	-19.26	Average
4	0.217	23.44	44.40	10.77	10.19	62.92	-18.52	QP
5	0.491	15.19	35.88	10.51	10.18	46.14	-10.26	Average
6	0.491	16.35	37.04	10.51	10.18	56.14	-19.10	QP
7	1.147	17.54	38.50	10.78	10.18	46.00	-7.50	Average
8	1.147	19.50	40.46	10.78	10.18	56.00	-15.54	QP
9	2.190	8.79	29.77	10.74	10.24	46.00	-16.23	Average
10	2.190	13.70	34.68	10.74	10.24	56.00	-21.32	QP
11	20.270	16.88	38.22	11.09	10.25	50.00	-11.78	Average
12	20.270	21.68	43.02	11.09	10.25	60.00	-16.98	QP

Radiated Emissions**Environmental Conditions**

Temperature (°C)	25.2&25.5	Relative Humidity (%)	50.1&52
ATM Pressure (kPa):	100.1&101.2	Test engineer:	Anson Su&Zenos Qiao
Test date:	2025.7.4~2025.7.14		
EUT operation mode:	Below 1GHz: Transmitting(Maximum output power mode, EDR (8DPSK) 2402MHz) Above 1GHz: Transmitting(Maximum output power mode, EDR (8DPSK))		
Note:	<ol style="list-style-type: none">1. For the radiated spurious emission below 30MHz, only the worst case (parallel) was recorded.2. For the radiated spurious emission below 1GHz, When the test result of peak was less than the limit of QP/Average more than 6dB, just peak value were recorded.3. After pre-scan in the X, Y and Z axes of orientation, the worst case z-axis of orientation were recorded.		

Below 1GHz:

USB Type-C Port

9kHz-150kHz

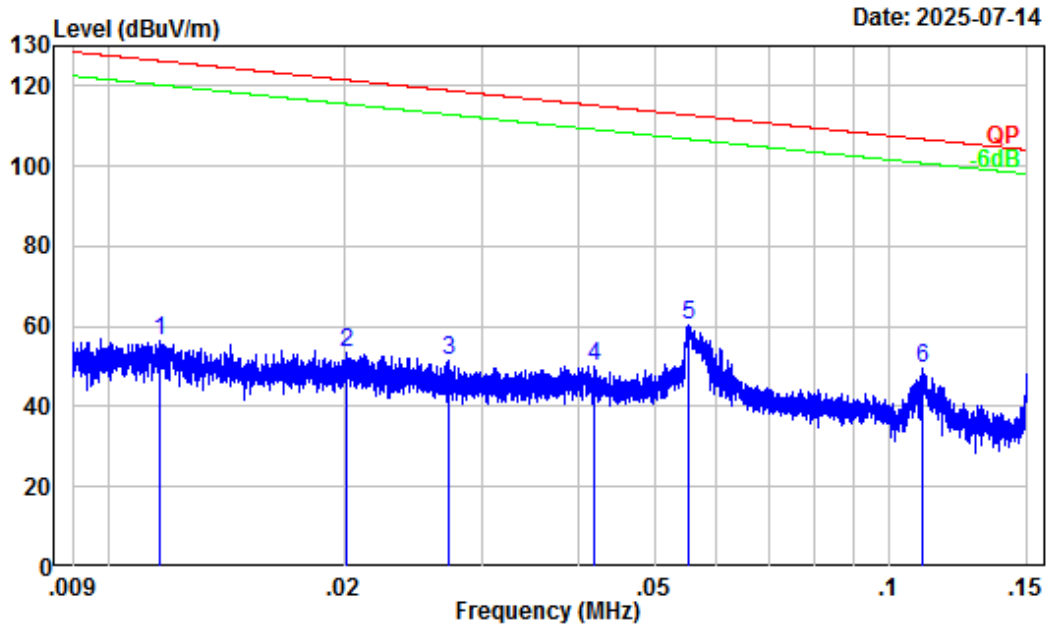

Site : Chamber A
 Condition : 3m
 Project Number : 2501U29284E-RF
 Test Mode : BT Transmitting
 Detector: Peak RBW/VBW: 0.3/1kHz
 Tester : Anson Su

	Freq	Factor	Read Level	Limit Level	Limit Line	Over Limit	Remark
	MHz	dB/m	dBuV	dBuV/m	dBuV/m	dB	
1	0.012	31.99	24.53	56.52	126.31	-69.79	Peak
2	0.020	30.37	22.96	53.33	121.52	-68.19	Peak
3	0.027	29.02	22.39	51.41	118.89	-67.48	Peak
4	0.042	27.27	22.75	50.02	115.19	-65.17	Peak
5	0.055	25.87	34.60	60.47	112.75	-52.28	Peak
6	0.110	21.42	28.16	49.58	106.79	-57.21	Peak

150kHz-30MHz

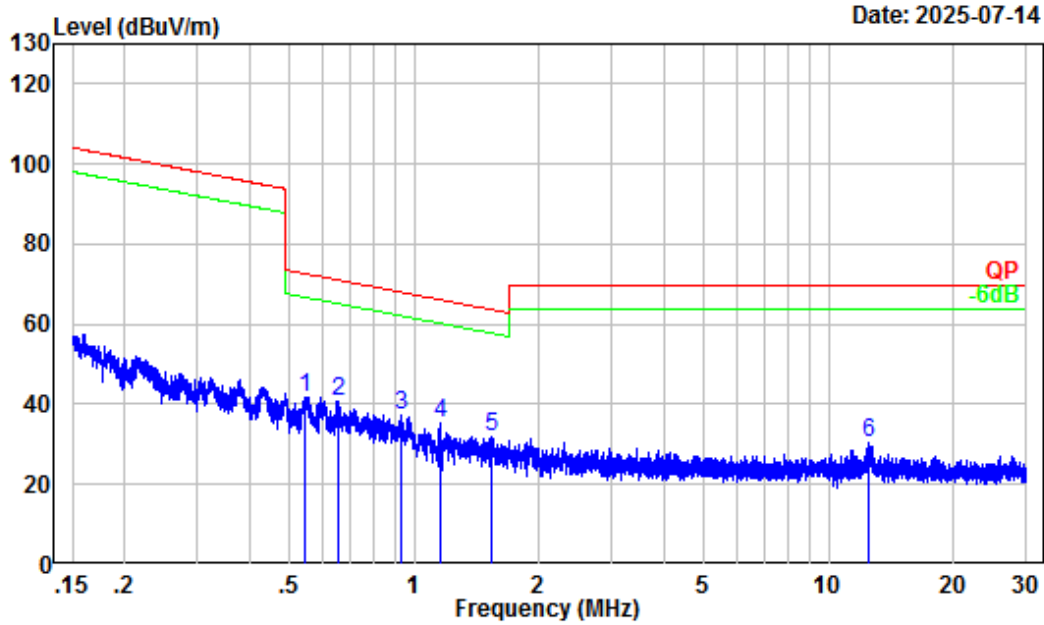

Site : Chamber A
 Condition : 3m
 Project Number : 2501U29284E-RF
 Test Mode : BT Transmitting
 Detector: Peak RBW/VBW: 10/30kHz
 Tester : Anson Su

	Freq	Factor	Read Level	Level	Limit Line	Over Limit	Remark
	MHz	dB/m	dBuV	dBuV/m	dBuV/m	dB	
1	0.545	5.84	35.87	41.71	72.85	-31.14	Peak
2	0.658	4.45	36.36	40.81	71.18	-30.37	Peak
3	0.933	1.71	35.63	37.34	68.09	-30.75	Peak
4	1.153	0.77	34.79	35.56	66.21	-30.65	Peak
5	1.533	-0.29	32.37	32.08	63.68	-31.60	Peak
6	12.458	-2.78	33.32	30.54	69.54	-39.00	Peak

30MHz-1GHz_Horizontal

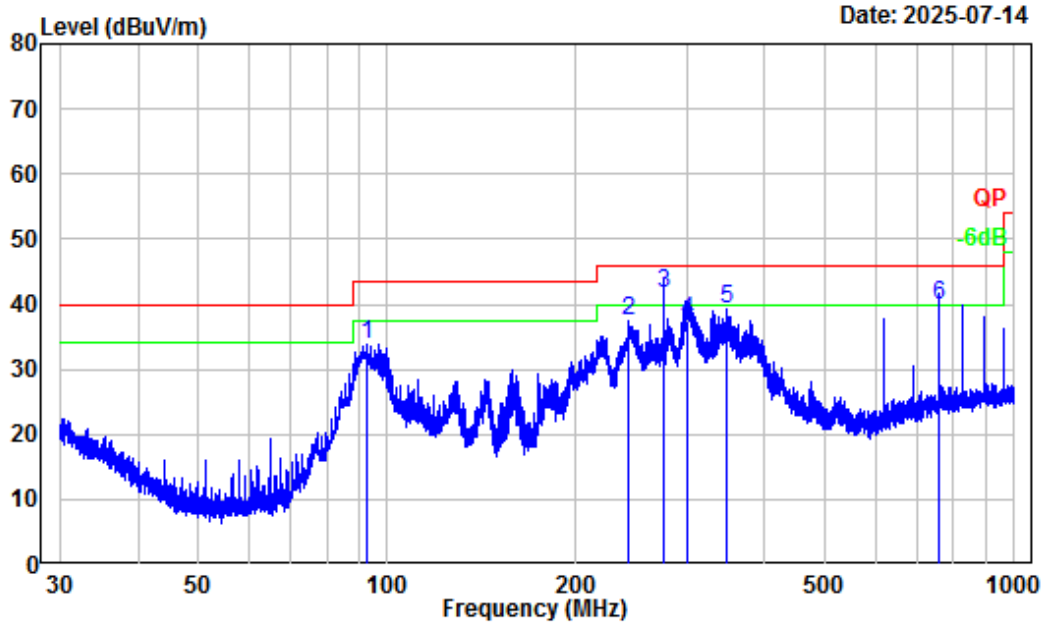

Site : Chamber A
 Condition : 3m Horizontal
 Project Number : 2501U29284E-RF
 Test Mode : BT Transmitting
 Detector: Peak RBW/VBW: 100/300kHz
 Tester : Anson Su

	Freq	Factor	Read Level	Limit Level	Limit Line	Over Limit	Remark
	MHz	dB/m	dBuV	dBuV/m	dBuV/m	dB	
1	92.50	-17.75	51.46	33.71	43.50	-9.79	Peak
2	243.06	-13.25	50.67	37.42	46.00	-8.58	Peak
3	275.76	-11.32	52.99	41.67	46.00	-4.33	QP
4	301.69	-11.16	48.60	37.44	46.00	-8.56	QP
5	348.64	-10.19	49.30	39.11	46.00	-6.89	Peak
6	758.37	-2.71	42.50	39.79	46.00	-6.21	QP

30MHz-1GHz_Vertical

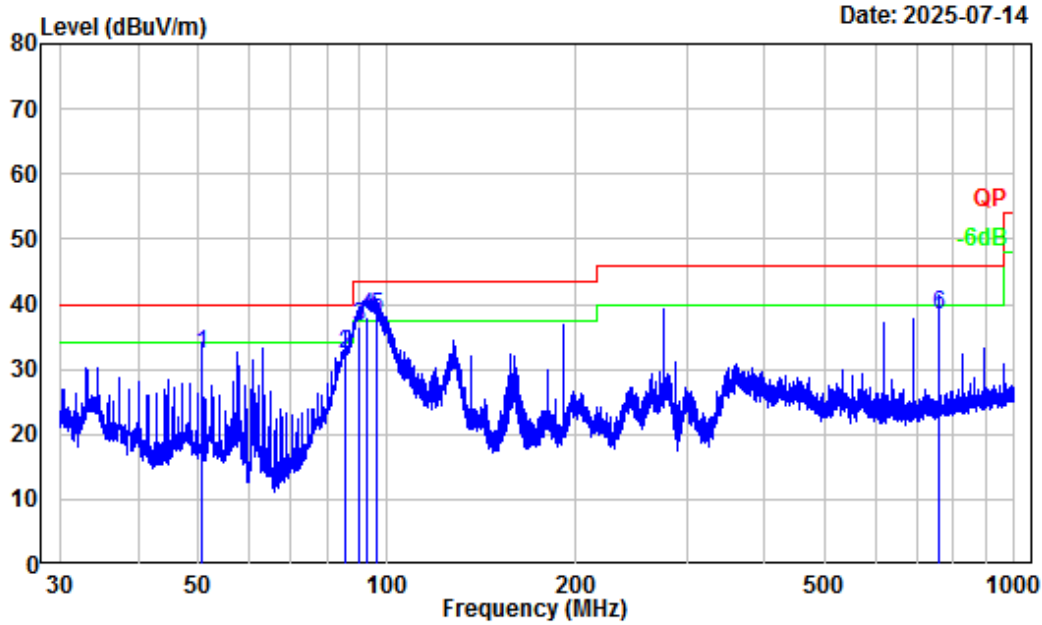

Date: 2025-07-14

Site : Chamber A
 Condition : 3m Vertical
 Project Number : 2501U29284E-RF
 Test Mode : BT Transmitting
 Detector: Peak RBW/VBW: 100/300kHz
 Tester : Anson Su

	Freq	Factor	Read Level	Level	Limit	Over	Remark
	MHz	dB/m	dBuV	dBuV/m	dBuV/m	dB	
1	50.54	-18.02	50.40	32.38	40.00	-7.62	QP
2	85.67	-18.09	50.31	32.22	40.00	-7.78	QP
3	89.90	-17.98	54.50	36.52	43.50	-6.98	QP
4	92.54	-17.74	55.80	38.06	43.50	-5.44	QP
5	95.93	-17.04	55.00	37.96	43.50	-5.54	QP
6	758.37	-2.71	41.00	38.29	46.00	-7.71	QP

Adapter

9kHz-150kHz

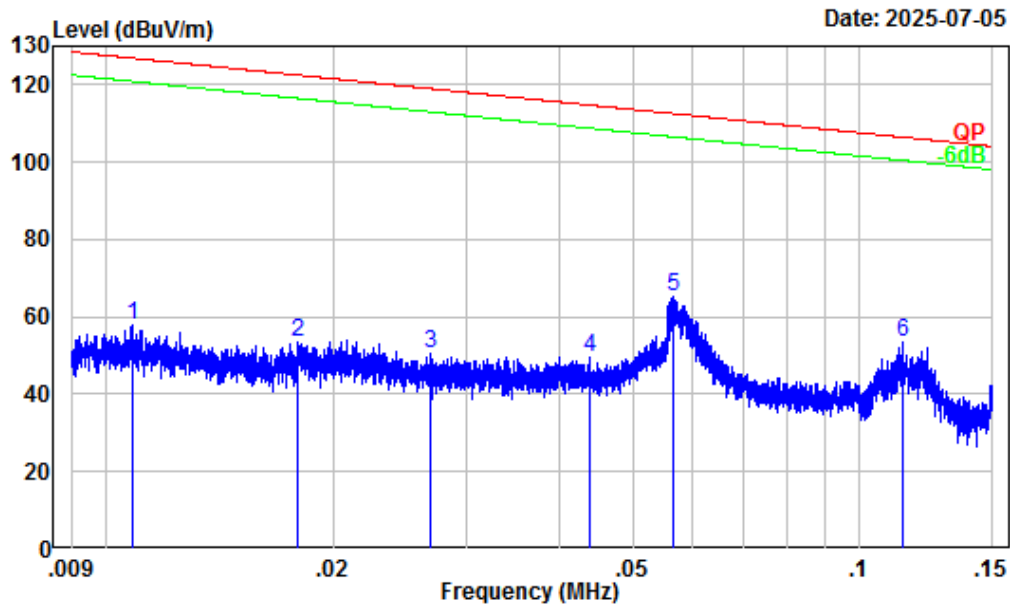

Site : Chamber A
 Condition : 3m
 Project Number : 2501U29284E-RF
 Test Mode : BT Transmitting
 Detector: Peak RBW/VBW: 0.3/1kHz
 Tester : Anson Su

	Freq	Factor	Read Level	Level	Limit Line	Over Limit	Remark
	MHz	dB/m	dBuV	dBuV/m	dBuV/m	dB	
1	0.011	32.14	25.99	58.13	126.90	-68.77	Peak
2	0.018	30.79	22.60	53.39	122.52	-69.13	Peak
3	0.027	29.08	21.40	50.48	118.99	-68.51	Peak
4	0.044	27.05	22.62	49.67	114.78	-65.11	Peak
5	0.057	25.73	39.59	65.32	112.53	-47.21	Peak
6	0.114	21.18	32.22	53.40	106.48	-53.08	Peak

150kHz-30MHz

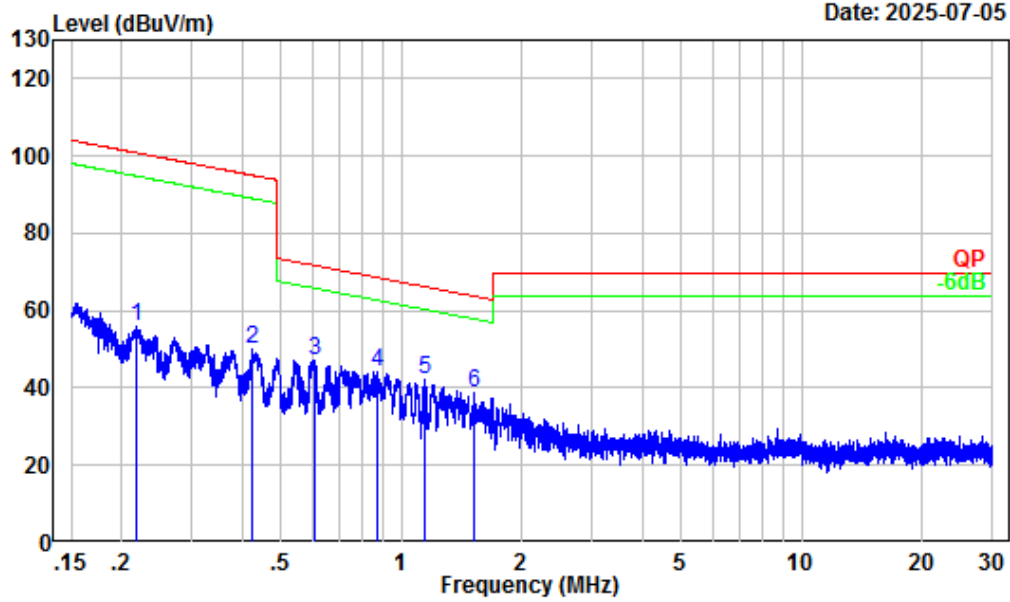

Site : Chamber A
 Condition : 3m
 Project Number : 2501U29284E-RF
 Test Mode : BT Transmitting
 Detector: Peak RBW/VBW: 100/300kHz
 Tester : Anson Su

	Freq	Factor	Read Level	Level	Limit Line	Over Limit	Remark
	MHz	dB/m	dBuV	dBuV/m	dBuV/m	dB	
1	0.218	15.05	41.10	56.15	100.84	-44.69	Peak
2	0.423	7.87	41.92	49.79	95.09	-45.30	Peak
3	0.608	5.07	41.95	47.02	71.89	-24.87	Peak
4	0.872	2.16	42.23	44.39	68.69	-24.30	Peak
5	1.149	0.78	41.58	42.36	66.24	-23.88	Peak
6	1.518	-0.25	39.00	38.75	63.77	-25.02	Peak

30MHz-1GHz_Horizontal

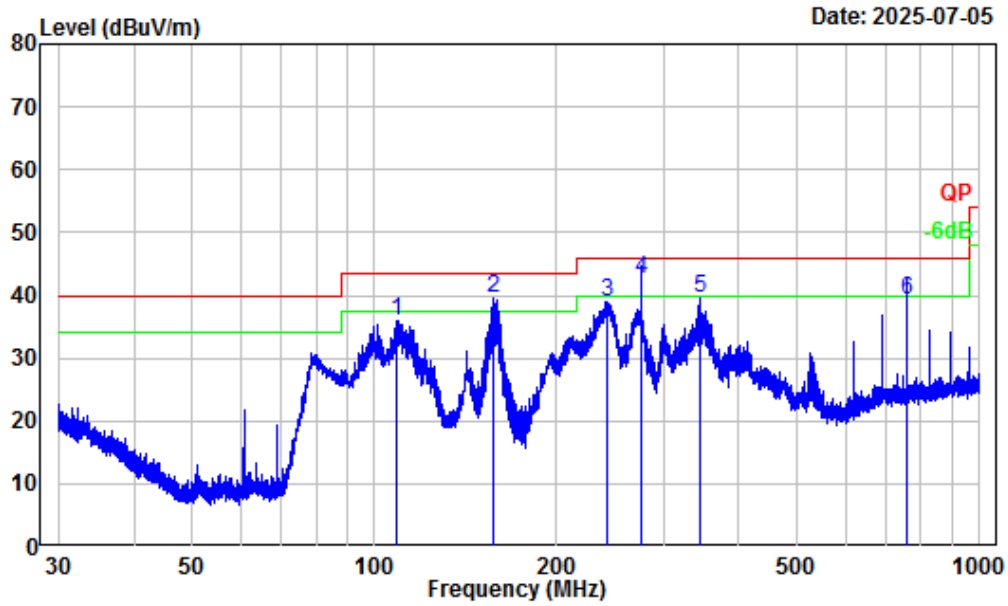

Site : Chamber A
 Condition : 3m Horizontal
 Project Number : 2501U29284E-RF
 Test Mode : BT Transmitting
 Detector: Peak RBW/VBW: 100/300kHz
 Tester : Anson Su

	Freq	Factor	Read Level	Limit Level	Over Limit	Remark
	MHz	dB/m	dBuV	dBuV/m	dBuV/m	dB
1	108.79	-13.45	49.26	35.81	43.50	-7.69 Peak
2	157.42	-12.63	52.08	39.45	43.50	-4.05 Peak
3	242.10	-13.27	52.16	38.89	46.00	-7.11 Peak
4	275.76	-11.32	53.99	42.67	46.00	-3.33 QP
5	344.69	-10.30	49.98	39.68	46.00	-6.32 Peak
6	758.37	-2.71	42.00	39.29	46.00	-6.71 QP

30MHz-1GHz_Vertical

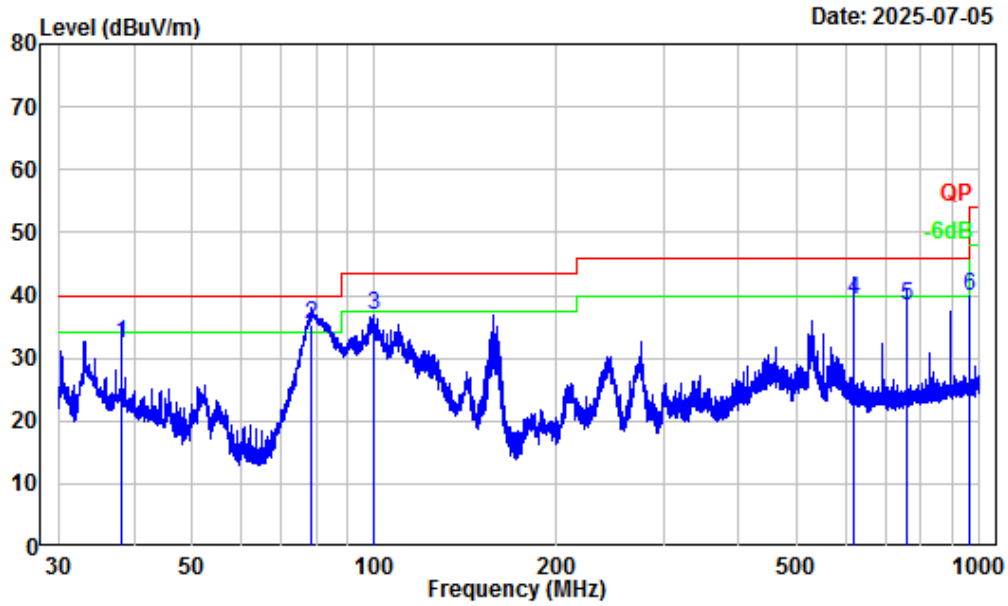

Site : Chamber A
 Condition : 3m Vertical
 Project Number : 2501U29284E-RF
 Test Mode : BT Transmitting
 Detector: Peak RBW/VBW: 100/300kHz
 Tester : Anson Su

	Freq	Factor	Read Level	Level	Limit Line	Over Limit	Remark
	MHz	dB/m	dBuV	dBuV/m	dBuV/m	dB	
1	38.25	-11.15	43.30	32.15	40.00	-7.85	QP
2	78.65	-17.88	53.31	35.43	40.00	-4.57	QP
3	99.44	-16.07	53.01	36.94	43.50	-6.56	Peak
4	620.44	-4.84	44.00	39.16	46.00	-6.84	QP
5	758.37	-2.71	41.00	38.29	46.00	-7.71	QP
6	965.12	-0.87	40.80	39.93	54.00	-14.07	Peak

Above 1GHz:

Frequency (MHz)	Reading (dBμV)	PK/Ave	Polar (H/V)	Factor (dB/m)	Corrected Amplitude (dBμV/m)	Limit (dBμV/m)	Margin (dB)
8DPSK							
Low Channel							
4804	51.69	PK	H	-7.79	43.9	74	-30.10
4804	52.06	PK	V	-7.79	44.27	74	-29.73
Middle Channel							
4882	52.37	PK	H	-7.58	44.79	74	-29.21
4882	52.72	PK	V	-7.58	45.14	74	-28.86
High Channel							
4960	53.18	PK	H	-7.56	45.62	74	-28.38
4960	53.54	PK	V	-7.56	45.98	74	-28.02

Note:

Factor = Antenna factor (RX) + Cable Loss – Amplifier Factor

Corrected Amplitude = Factor + Reading

Margin = Corrected. Amplitude - Limit

The other spurious emission which is in the noise floor level was not recorded.

The test result of peak was less than the limit of average, so just peak values were recorded.

Test plots:

Band Edge

Left Band edge_Horizontal_Peak_BT_3DH5_2402MHz

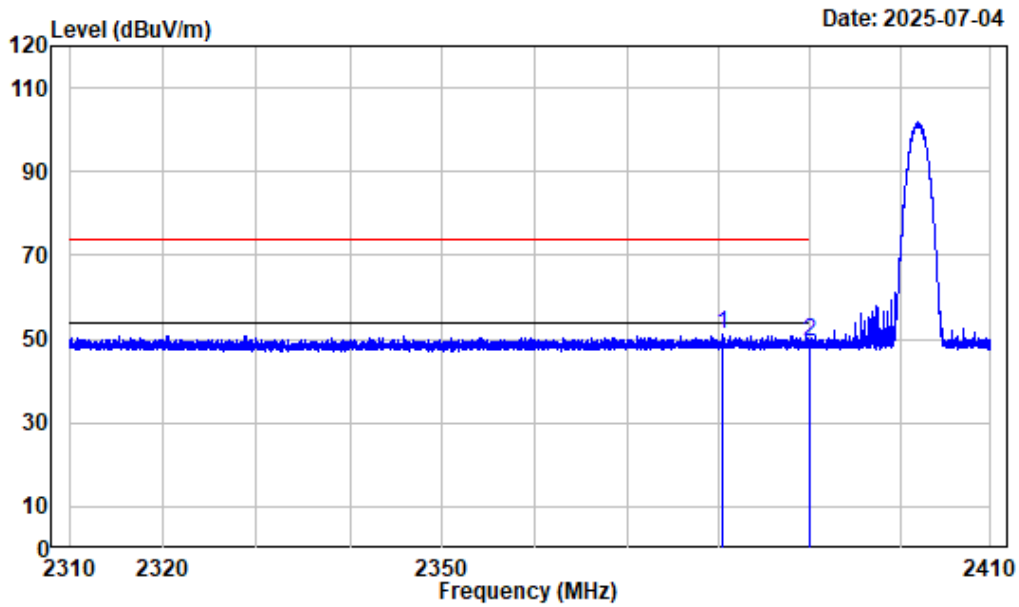

Condition : Horizontal
 Project No. : 2501U29284E-RF
 Tester : Zenos Qiao
 Spectrum setting: Peak reading:RBW:1MHz VBW:3MHz Detector:Peak
 Note : BT-3DH5-2402

	Freq Factor		Read Level		Limit	Over	Remark
	MHz	dB/m	dBuV	dBuV/m	Line	Limit	
1	2380.384	-10.96	61.95	50.99	74.00	-23.01	Peak
2	2390.000	-10.98	60.38	49.40	74.00	-24.60	Peak

Left Band edge_Veritical_Peak_BT_3DH5_2402MHz

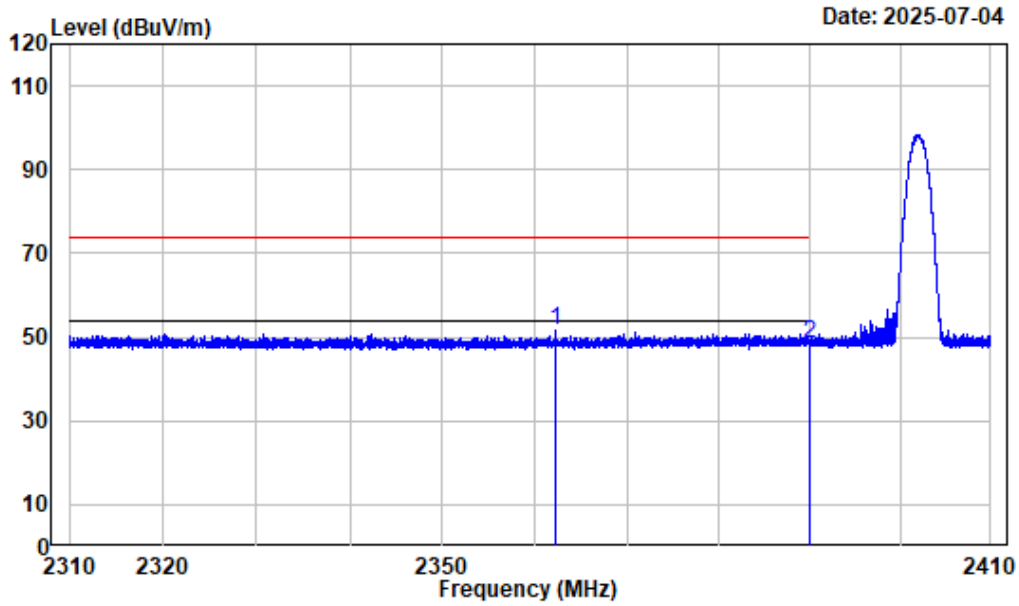

Condition : Vertical
 Project No. : 2501U29284E-RF
 Tester : Zenos Qiao
 Spectrum setting: Peak reading:RBW:1MHz VBW:3MHz Detector:Peak
 Note : BT-3DH5-2402

	Freq	Factor	Read Level	Level	Limit Line	Over Limit	Remark
	MHz	dB/m	dBuV	dBuV/m	dBuV/m	dB	
1	2362.257	-10.91	62.33	51.42	74.00	-22.58	Peak
2	2390.000	-10.98	59.37	48.39	74.00	-25.61	Peak

Right Band edge_Horizontal_Peak_BT_3DH5_2480MHz

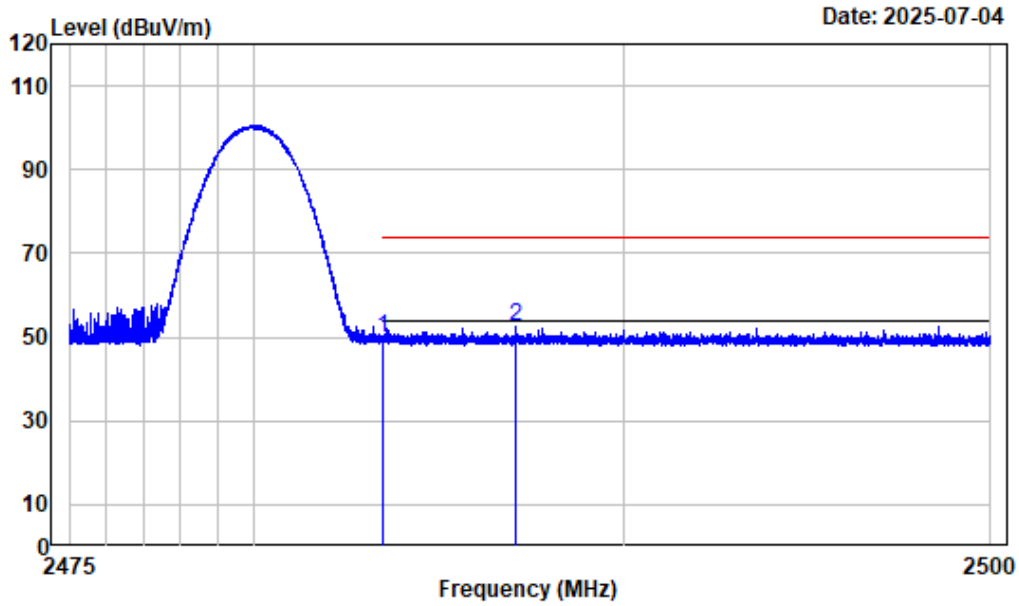

Condition : Horizontal
 Project No. : 2501U29284E-RF
 Tester : Zenos Qiao
 Spectrum setting: Peak reading:RBW:1MHz VBW:3MHz Detector:Peak
 Note : BT-3DH5-2480

	Freq	Factor	Read Level	Level	Limit Line	Over Limit	Remark
	MHz	dB/m	dBuV	dBuV/m	dBuV/m	dB	
1	2483.500	-10.97	60.58	49.61	74.00	-24.39	Peak
2	2487.102	-10.97	63.35	52.38	74.00	-21.62	Peak

Right Band edge_Vertical_Peak_BT_3DH5_2480MHz

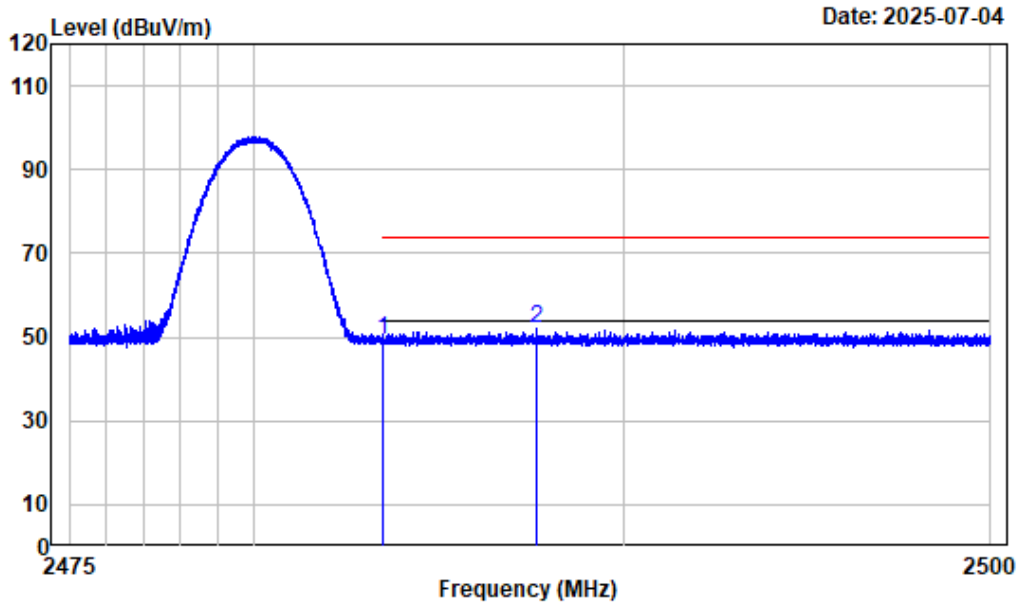

Condition : Vertical
 Project No. : 2501U29284E-RF
 Tester : Zenos Qiao
 Spectrum setting: Peak reading:RBW:1MHz VBW:3MHz Detector:Peak
 Note : BT-3DH5-2480

	Freq	Factor	Read Level	Level	Limit Line	Over Limit	Remark
	MHz	dB/m	dBuV	dBuV/m	dBuV/m	dB	
1	2483.500	-10.97	60.26	49.29	74.00	-24.71	Peak
2	2487.670	-10.98	62.88	51.90	74.00	-22.10	Peak

1-25GHz (Listed with the worst harmonic margin test plot)

1-4GHz_Horizontal_BT_3DH5_2480MHz

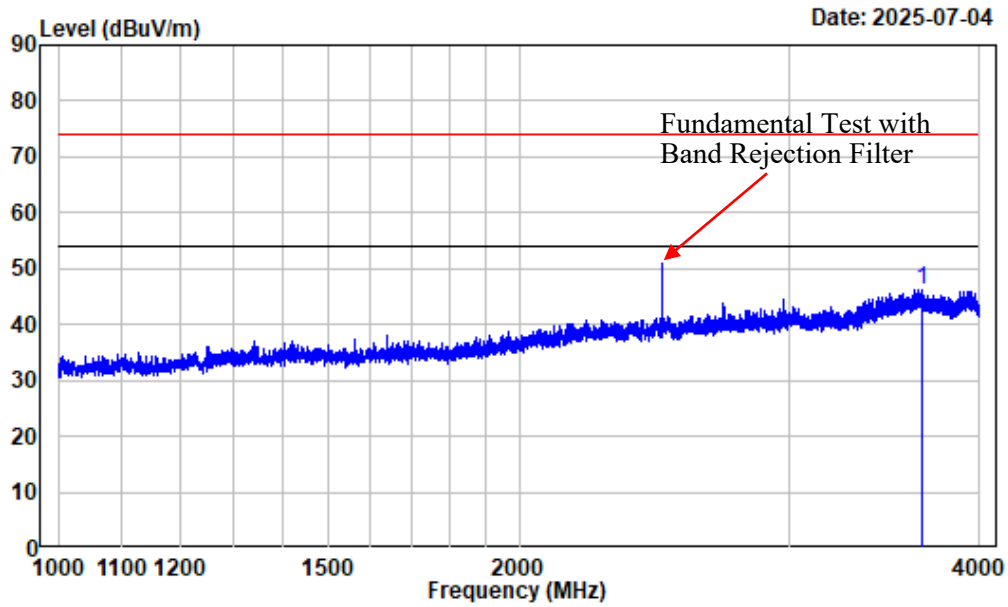

Condition : Horizontal
 Project No. : 2501U29284E-RF
 Tester : Zenos Qiao
 Spectrum setting: Peak reading:RBW:1MHz VBW:3MHz Detector:Peak
 Note : BT-3DH5-2480

1	Freq Factor		Read Level		Limit	Over	Remark
	MHz	dB/m	dBuV	dBuV/m	dBuV/m	dB	
	3671.459	-9.65	56.00	46.35	74.00	-27.65	Peak

1-4GHz_Vertical_BT_3DH5_2480MHz

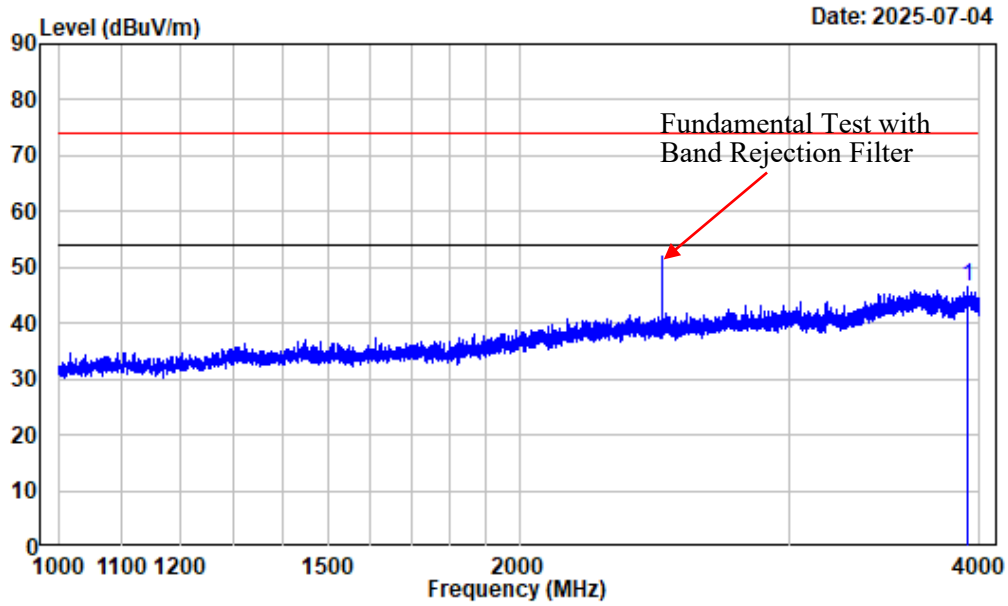

Condition : Vertical
 Project No. : 2501U29284E-RF
 Tester : Zenos Qiao
 Spectrum setting: Peak reading:RBW:1MHz VBW:3MHz Detector:Peak
 Note : BT-3DH5-2480

Freq Factor		Read Level	Level	Limit Line	Over Limit	Remark
MHz	dB/m	dBuV	dBuV/m	dBuV/m	dB	
1	3926.116	-9.57	56.18	46.61	74.00	-27.39 Peak

4-18GHz_Horizontal_Peak_BT_3DH5_2480MHz

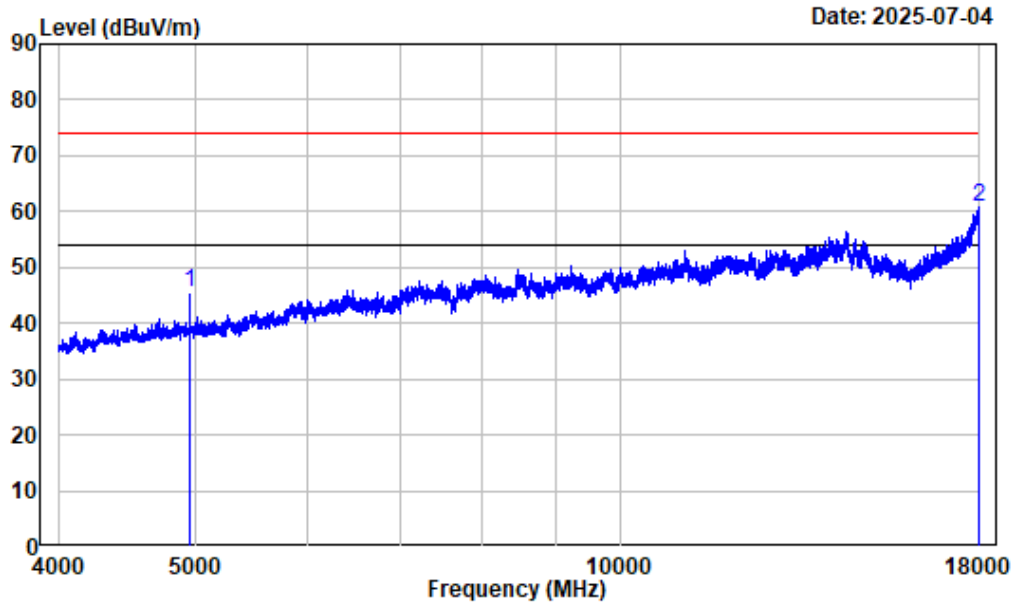

Condition : Horizontal
 Project No. : 2501U29284E-RF
 Tester : Zenos Qiao
 Spectrum setting: Peak reading:RBW:1MHz VBW:3MHz Detector:Peak
 Note : BT-3DH5-2480

Freq Factor		Read Level	Level	Limit Line	Over Limit	Remark
MHz	dB/m	dBuV	dBuV/m	dBuV/m	dB	
1	4960.000	-7.56	53.18	45.62	74.00	-28.38 Peak
2	17986.000	13.13	47.80	60.93	74.00	-13.07 Peak

4-18GHz_Horizontal_Average_BT_3DH5_2480MHz

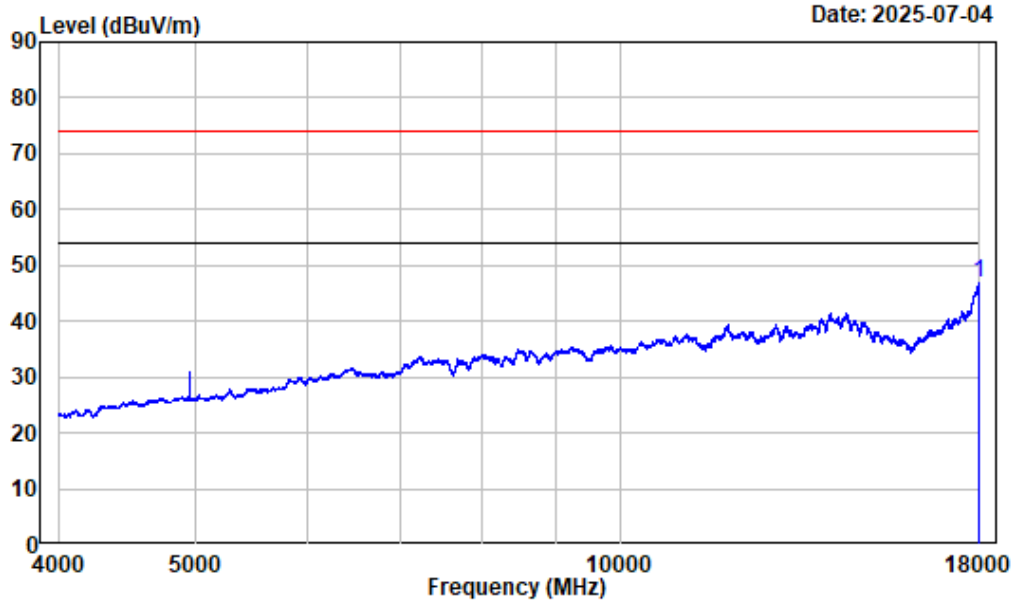

Condition : Horizontal
 Project No. : 2501U29284E-RF
 Tester : Zenos Qiao
 Spectrum setting: Average reading:RBW:1MHz VBW:1kHz Detector:Peak
 Note : BT-3DH5-2480

Freq Factor		Read Level	Level	Limit Line	Over Limit	Remark
MHz	dB/m	dBuV	dBuV/m	dBuV/m	dB	
1 17996.500	13.19	33.59	46.78	54.00	-7.22	Average

4-18GHz_Vertical_Peak_BT_3DH5_2480MHz

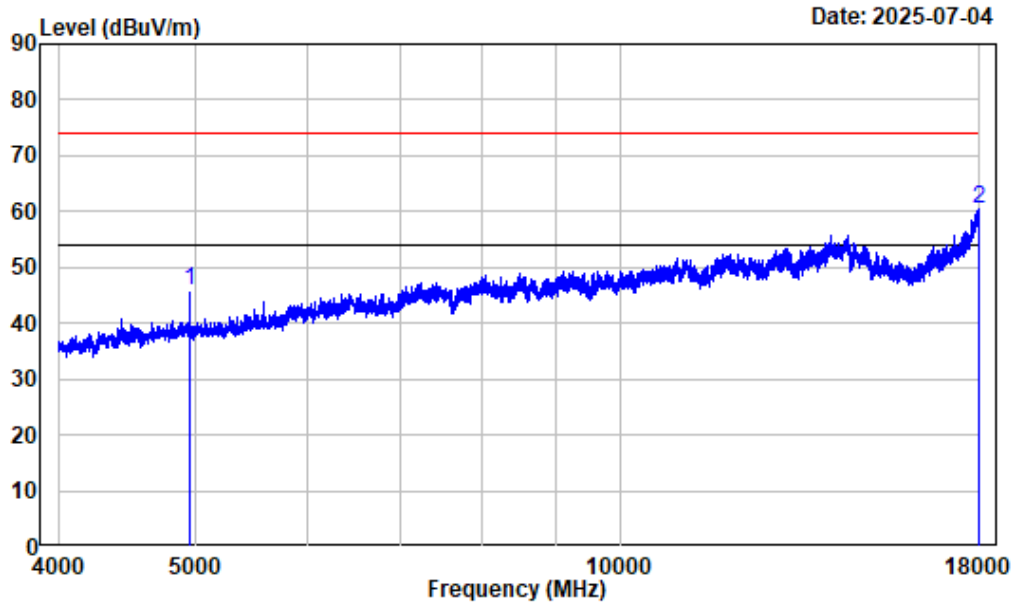

Condition : Vertical
 Project No. : 2501U29284E-RF
 Tester : Zenos Qiao
 Spectrum setting: Peak reading:RBW:1MHz VBW:3MHz Detector:Peak
 Note : BT-3DH5-2480

Freq Factor		Read Level	Level	Limit Line	Over Limit	Remark
MHz	dB/m	dBuV	dBuV/m	dBuV/m	dB	
1	4960.000	-7.56	53.54	45.98	74.00	-28.02 Peak
2	17996.500	13.19	47.40	60.59	74.00	-13.41 Peak

4-18GHz_Vertical_Average_BT_3DH5_2480MHz

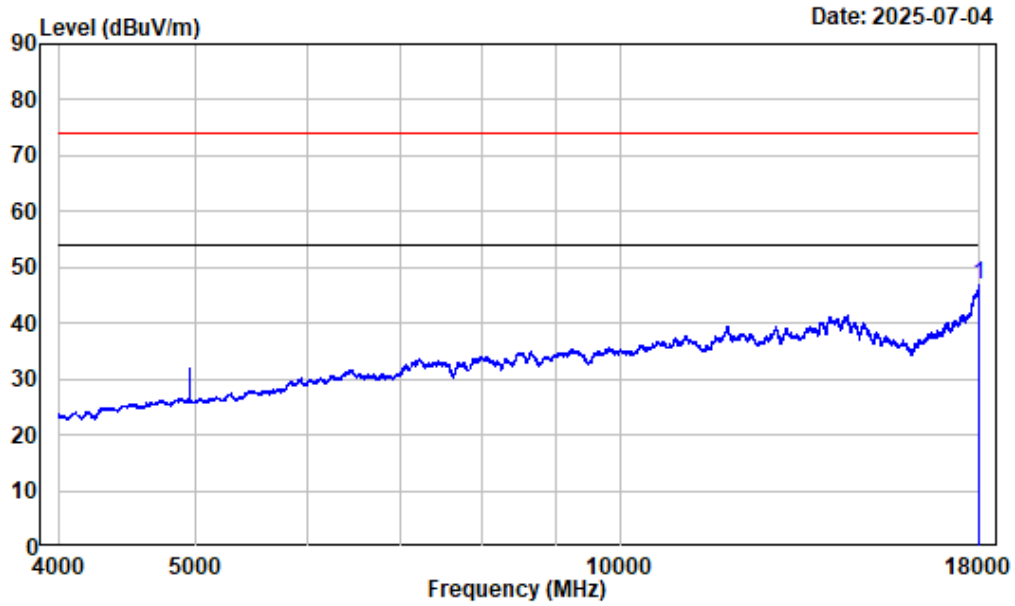

Condition : Vertical
 Project No. : 2501U29284E-RF
 Tester : Zenos Qiao
 Spectrum setting: Average reading:RBW:1MHz VBW:1kHz Detector:Peak
 Note : BT-3DH5-2480

Freq Factor		Read Level	Level	Limit Line	Over Limit	Remark
MHz	dB/m	dBuV	dBuV/m	dBuV/m	dB	
1 17998.630	13.20	33.72	46.92	54.00	-7.08	Average

18-25GHz_Horizontal_BT_3DH5_2480MHz

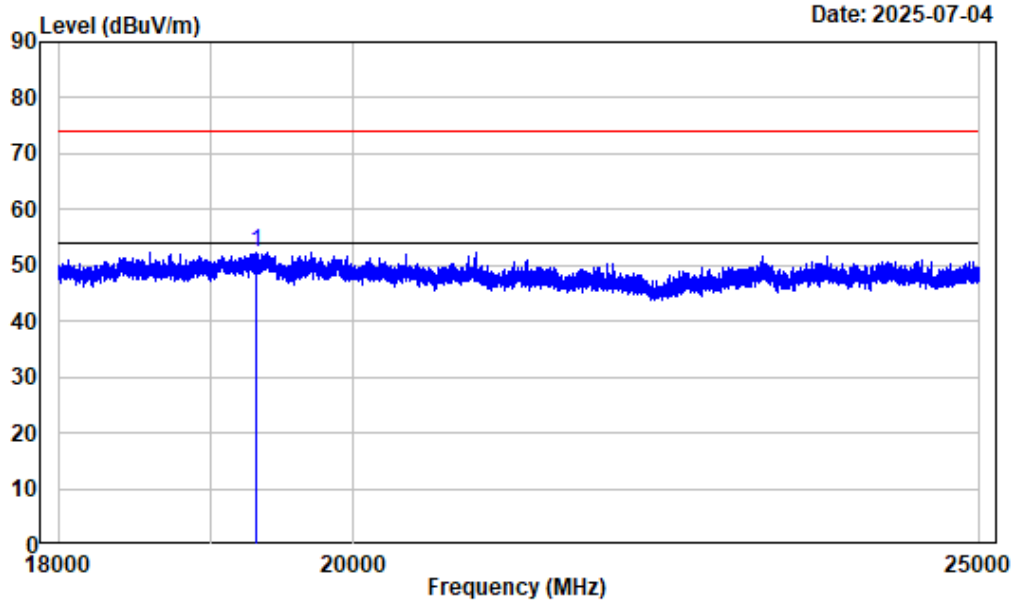

Condition : Horizontal
 Project No. : 2501U29284E-RF
 Tester : Zenos Qiao
 Spectrum setting: Peak reading:RBW:1MHz VBW:3MHz Detector:Peak
 Note : BT-3DH5-2480

Freq Factor		Read Level	Level	Limit Line	Over Limit	Remark
MHz	dB/m	dBuV	dBuV/m	dBuV/m	dB	
1 19314.410	15.42	36.97	52.39	74.00	-21.61	peak

18-25GHz_Veritical_BT_3DH5_2480MHz

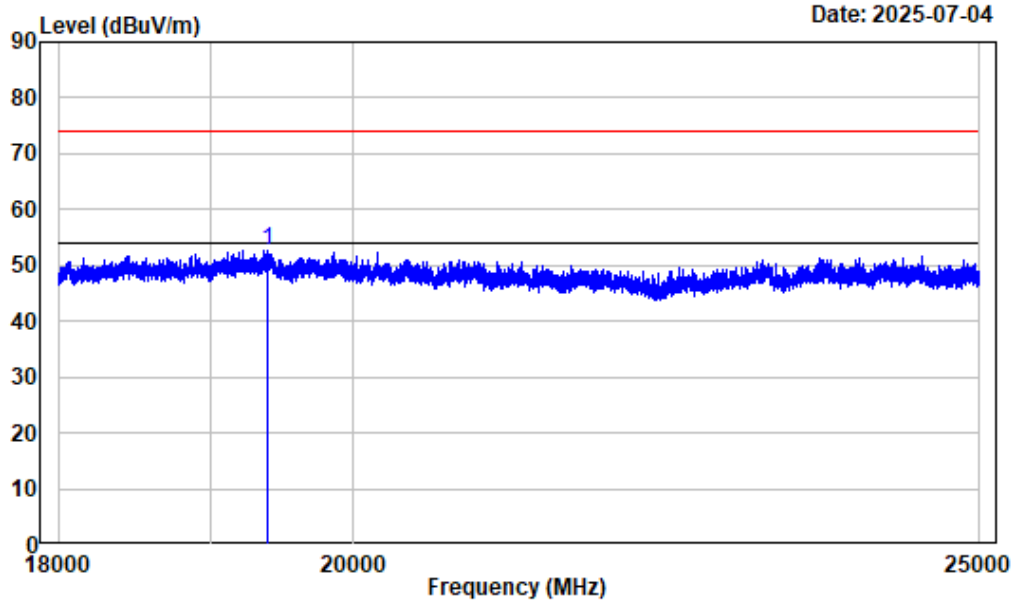

Condition : Vertical
 Project No. : 2501U29284E-RF
 Tester : Zenos Qiao
 Spectrum setting: Peak reading:RBW:1MHz VBW:3MHz Detector:Peak
 Note : BT-3DH5-2480

Freq Factor		Read Level	Level	Limit Line	Over Limit	Remark
MHz	dB/m	dBuV	dBuV/m	dBuV/m	dB	
1 19392.300	15.45	37.35	52.80	74.00	-21.20	Peak

20 dB Emission Bandwidth

Test Information:

Sample No.:	348G-1	Test Date:	2025/06/30
Test Site:	RF	Test Mode:	Transmitting
Tester:	Cheeb Huang	Test Result:	Pass

Environmental Conditions:

Temperature: (°C)	25.1	Relative Humidity: (%)	51	ATM Pressure: (kPa)	101.4
-----------------------------	------	----------------------------------	----	-------------------------------	-------

Test Data:

Mode	Channel	Result (MHz)
DH1	Low Channel	0.814
	Middle Channel	0.772
	High Channel	0.772
2DH1	Low Channel	1.267
	Middle Channel	1.264
	High Channel	1.264
3DH1	Low Channel	1.279
	Middle Channel	1.279
	High Channel	1.276

DH1_Low

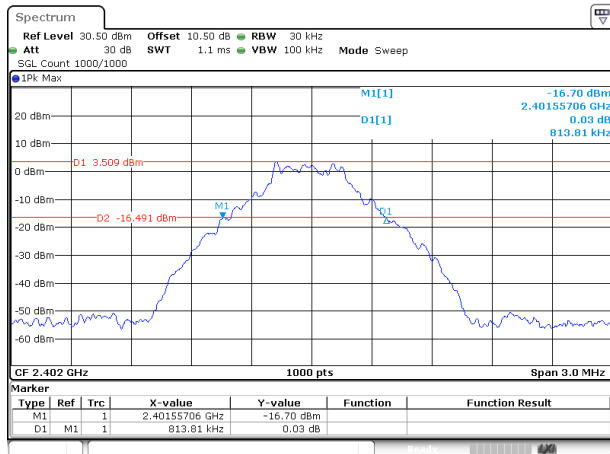

ProjectNo.:2501U29284E-RF Tester:Cheeb Huang
Date: 30 JUN 2025 15:14:22

DH1_Middle

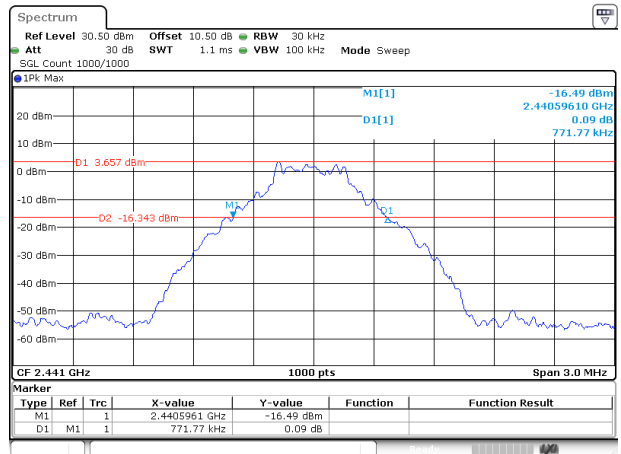

ProjectNo.:2501U29284E-RF Tester:Cheeb Huang
Date: 30 JUN 2025 15:22:06

DH1_High

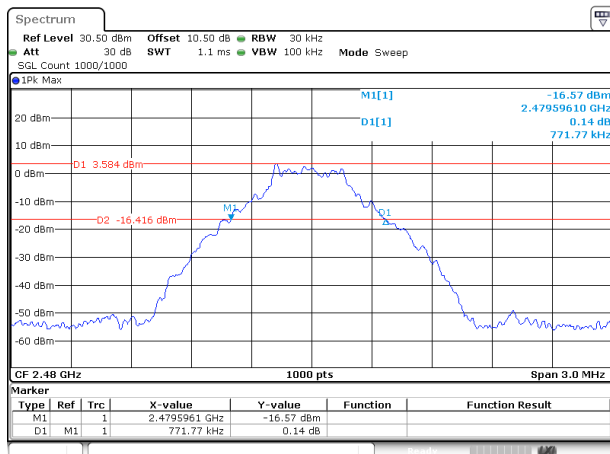

ProjectNo.:2501U29284E-RF Tester:Cheeb Huang
Date: 30 JUN 2025 15:24:15

2DH1_Low

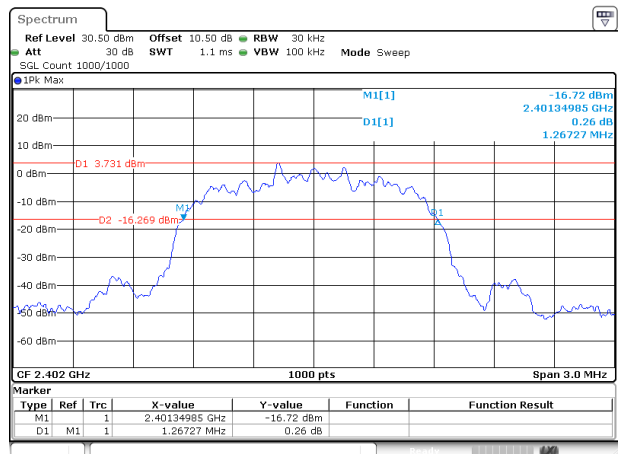

ProjectNo.:2501U29284E-RF Tester:Cheeb Huang
Date: 30 JUN 2025 15:31:06

2DH1_Middle

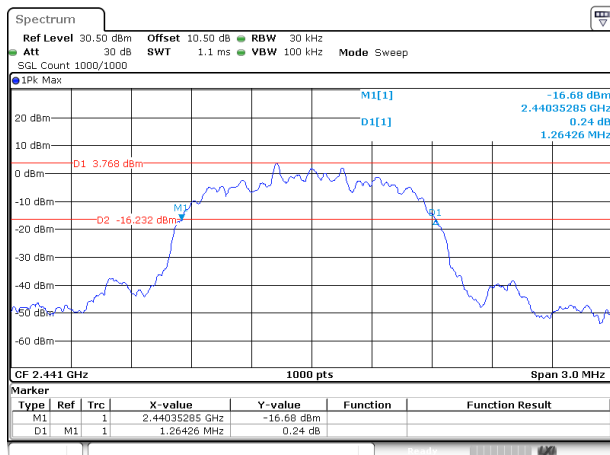

ProjectNo.:2501U29284E-RF Tester:Cheeb Huang
Date: 30 JUN 2025 15:32:20

2DH1_High

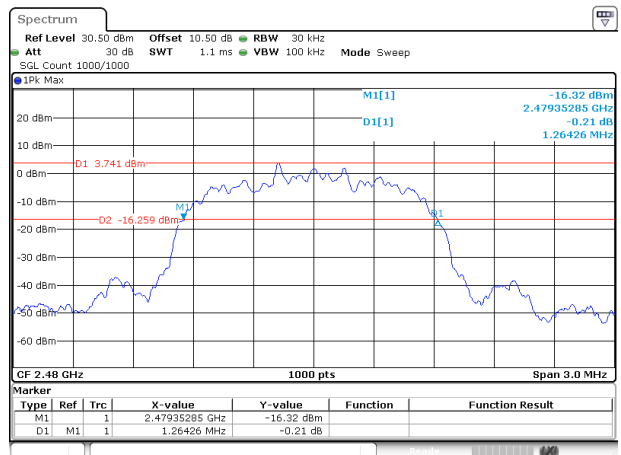

ProjectNo.:2501U29284E-RF Tester:Cheeb Huang
Date: 30 JUN 2025 15:33:22

3DH1_Low

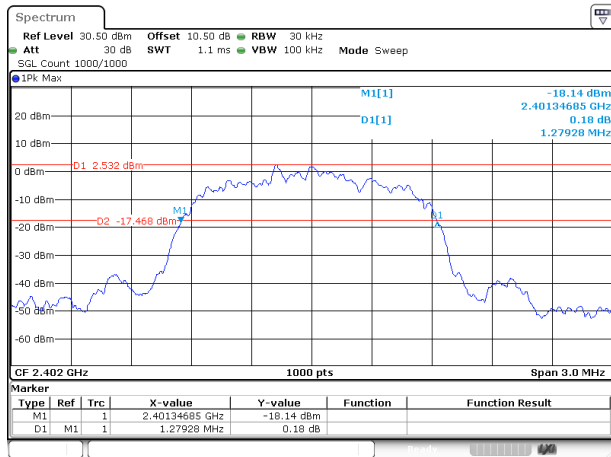

ProjectNo.:2501U29284E-RF Tester:Cheeb Huang
 Date: 30 JUN.2025 15:34:19

3DH1_Middle

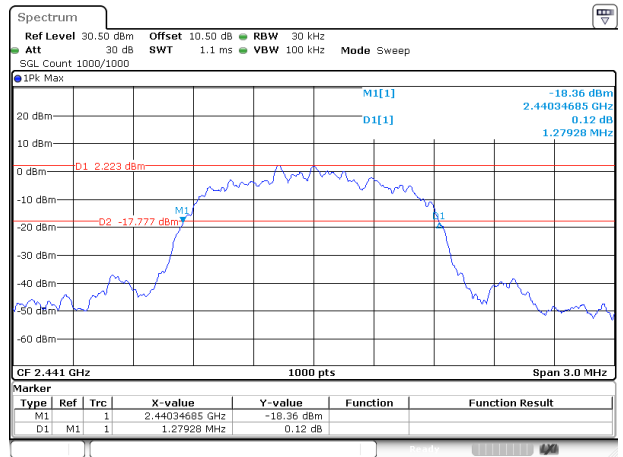

ProjectNo.:2501U29284E-RF Tester:Cheeb Huang
 Date: 30 JUN.2025 15:35:20

3DH1_High

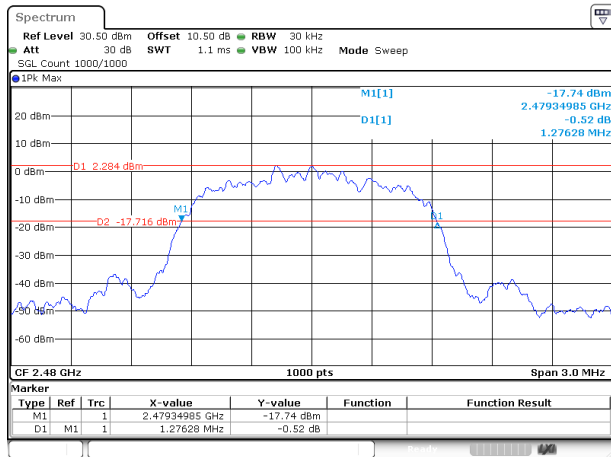

ProjectNo.:2501U29284E-RF Tester:Cheeb Huang
 Date: 30 JUN.2025 15:36:25

99% Occupied Bandwidth

Test Information:

Sample No.:	348G-1	Test Date:	2025/06/30
Test Site:	RF	Test Mode:	Transmitting
Tester:	Cheeb Huang	Test Result:	N/A

Environmental Conditions:

Temperature: (°C)	25.1	Relative Humidity: (%)	51	ATM Pressure: (kPa)	101.4
-----------------------------	------	----------------------------------	----	-------------------------------	-------

Test Data:

Mode	Channel	99% OBW (MHz)
DH1	Low Channel	0.720
	Middle Channel	0.720
	High Channel	0.720
2DH1	Low Channel	1.161
	Middle Channel	1.161
	High Channel	1.161
3DH1	Low Channel	1.161
	Middle Channel	1.158
	High Channel	1.158

DH1_Low

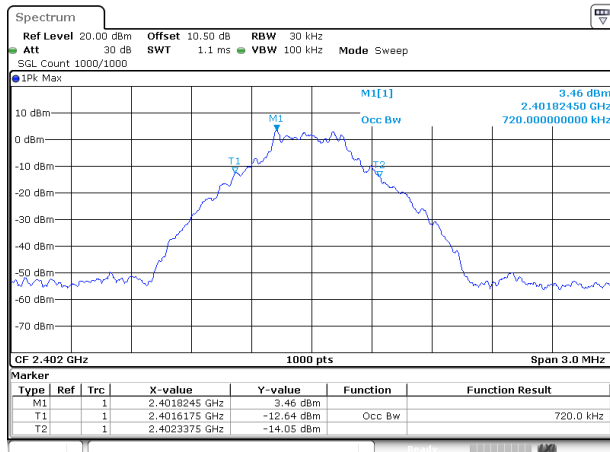

ProjectNo.:2501U29284E-RF Tester:Cheeb Huang
Date: 30 JUN 2025 15:14:38

DH1_Middle

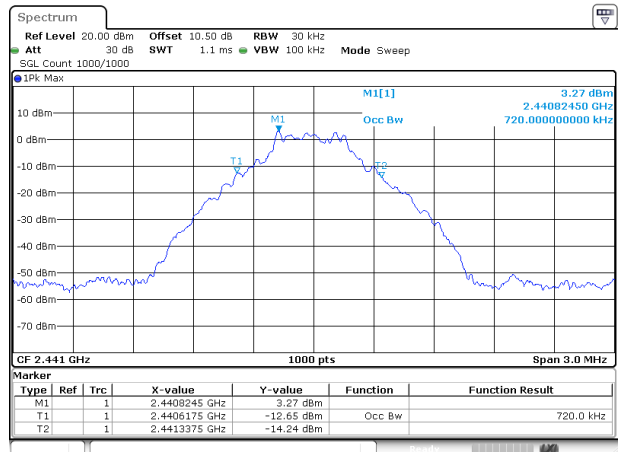

ProjectNo.:2501U29284E-RF Tester:Cheeb Huang
Date: 30 JUN 2025 15:22:21

DH1_High

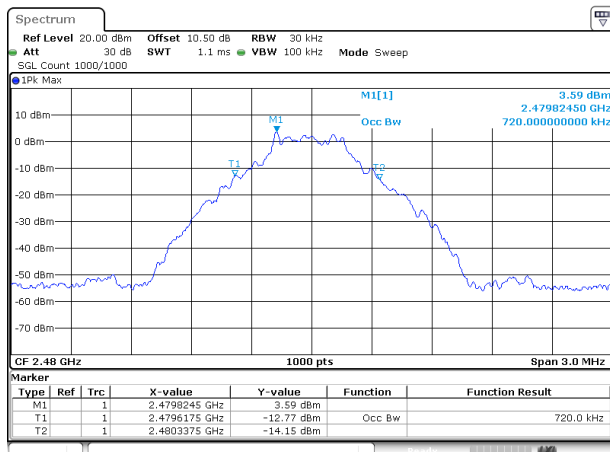

ProjectNo.:2501U29284E-RF Tester:Cheeb Huang
Date: 30 JUN 2025 15:24:30

2DH1_Low

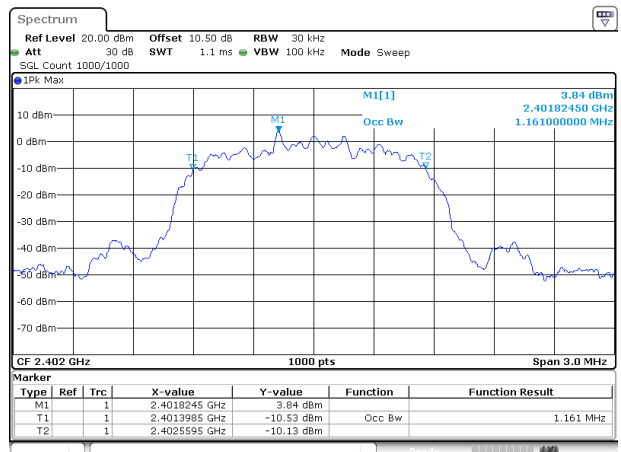

ProjectNo.:2501U29284E-RF Tester:Cheeb Huang
Date: 30 JUN 2025 15:31:21

2DH1_Middle

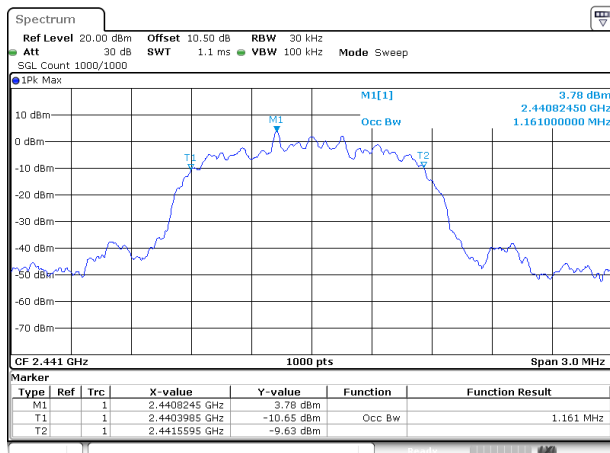

ProjectNo.:2501U29284E-RF Tester:Cheeb Huang
Date: 30 JUN 2025 15:32:35

2DH1_High

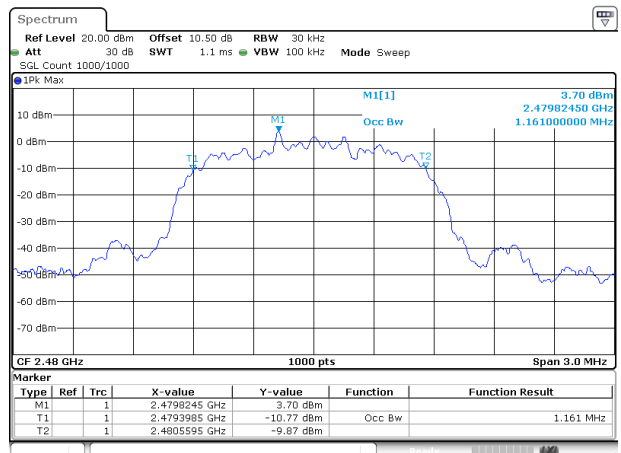

ProjectNo.:2501U29284E-RF Tester:Cheeb Huang
Date: 30 JUN 2025 15:33:37

3DH1_Low

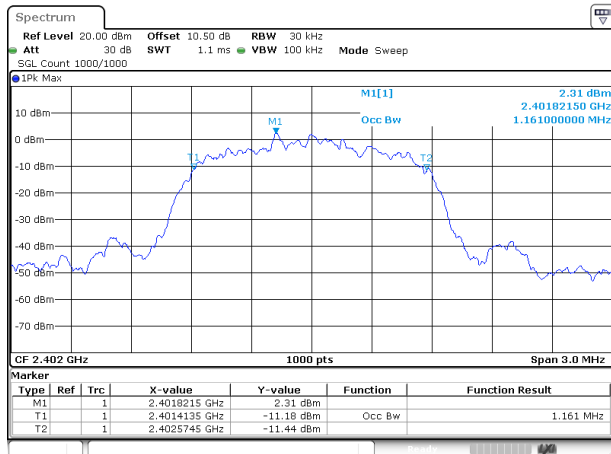

ProjectNo.:2501U29284E-RF Tester:Cheeb Huang
 Date: 30 JUN 2025 15:34:34

3DH1_Middle

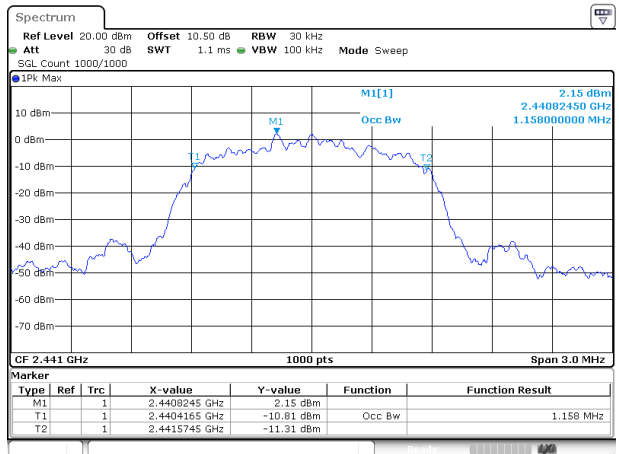

ProjectNo.:2501U29284E-RF Tester:Cheeb Huang
 Date: 30 JUN 2025 15:35:35

3DH1_High

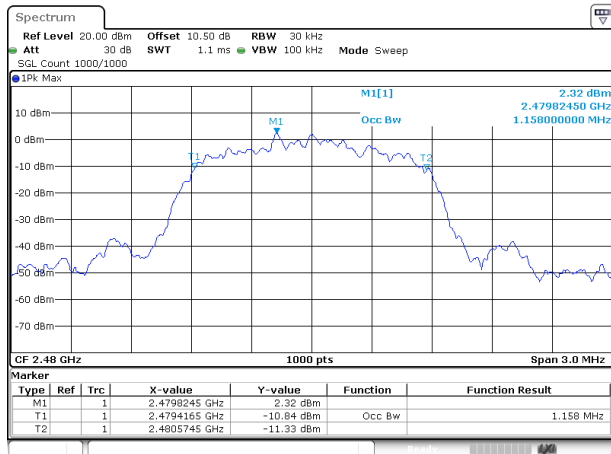

ProjectNo.:2501U29284E-RF Tester:Cheeb Huang
 Date: 30 JUN 2025 15:36:40

Channel Separation**Test Information:**

Sample No.:	348G-1	Test Date:	2025/06/30
Test Site:	RF	Test Mode:	Transmitting
Tester:	Cheeb Huang	Test Result:	Pass

Environmental Conditions:

Temperature: (°C)	25.1	Relative Humidity: (%)	51	ATM Pressure: (kPa)	101.4
-----------------------------	------	----------------------------------	----	-------------------------------	-------

Test Data:

Mode	Channel	Result (MHz)	Limit (MHz)	Verdict
DH1	Low Channel	1.001	0.853	Pass
	Middle Channel	1.001	0.853	Pass
	High Channel	1.003	0.851	Pass

Note: Only the BDR (GFSK) mode result is reported since EDR ($\pi/4$ -DQPSK) and EDR (8DPSK) modes have the exact same channel plan, and the limit is the maximum 20dB bandwidth *2/3.

DH1_Low

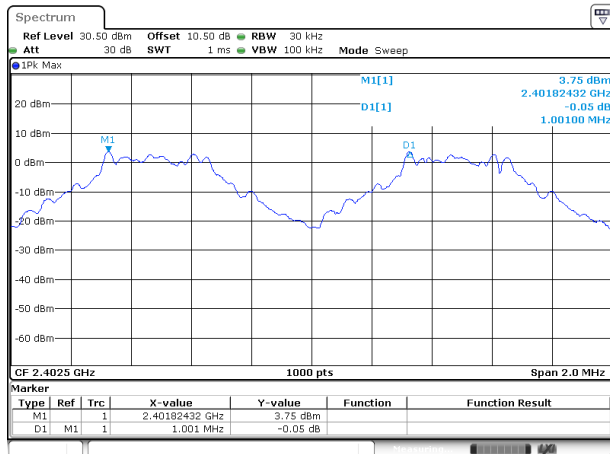

ProjectNo.:2501U29284E-RF Tester:Cheeb Huang
Date: 30_JUN.2025 15:21:30

DH1_Middle

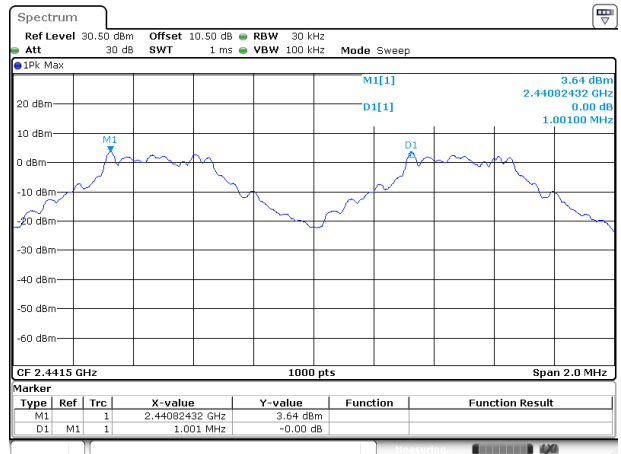

ProjectNo.:2501U29284E-RF Tester:Cheeb Huang
Date: 30_JUN.2025 15:23:43

DH1_High

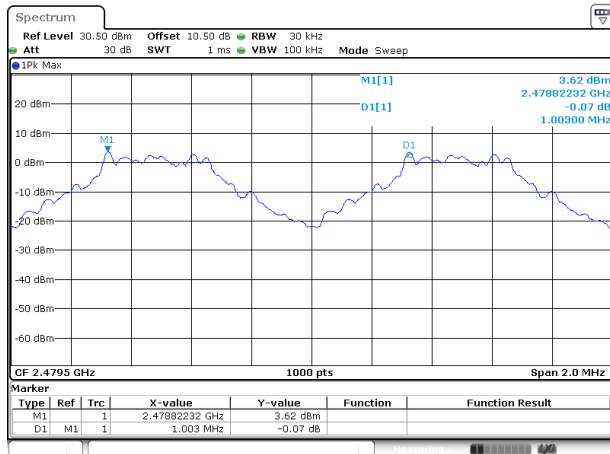

ProjectNo.:2501U29284E-RF Tester:Cheeb Huang
Date: 30_JUN.2025 15:25:27

Number of Hopping Frequency**Test Information:**

Sample No.:	348G-1	Test Date:	2025/06/30
Test Site:	RF	Test Mode:	Transmitting
Tester:	Cheeb Huang	Test Result:	Pass

Environmental Conditions:

Temperature: (°C)	25.1	Relative Humidity: (%)	51	ATM Pressure: (kPa)	101.4
------------------------------	------	---------------------------------------	----	--------------------------------	-------

Test Data:

Mode	Channel	Result	Limit	Verdict
DH1	Hopping Channel	79	15	Pass
2DH1	Hopping Channel	79	15	Pass
3DH1	Hopping Channel	79	15	Pass

DH1_Hopping

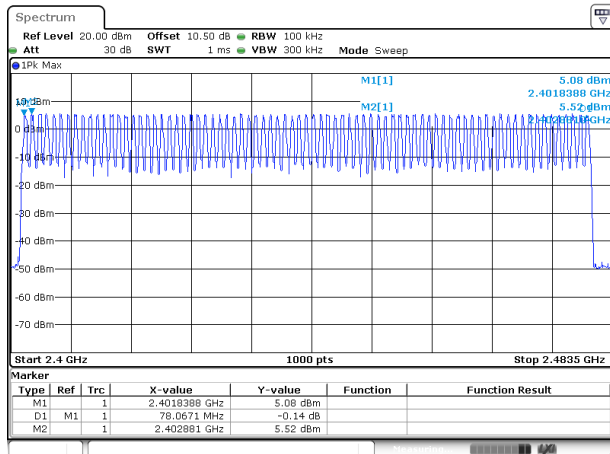

ProjectNo.:2501U29284E-RF Tester:Cheeb Huang
Date: 30 JUN 2025 16:24:01

2DH1_Hopping

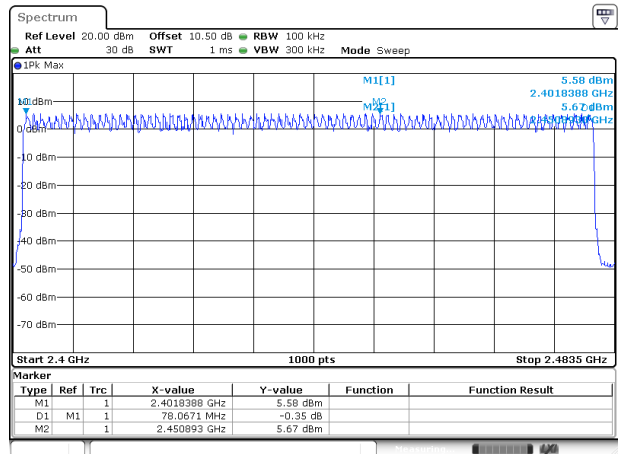

ProjectNo.:2501U29284E-RF Tester:Cheeb Huang
Date: 30 JUN 2025 16:25:44

3DH1_Hopping

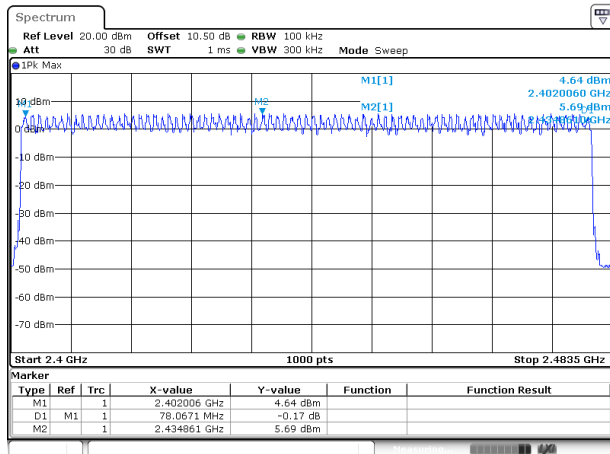

ProjectNo.:2501U29284E-RF Tester:Cheeb Huang
Date: 30 JUN 2025 16:27:22

Maximum Conducted Output Power

Test Information:

Sample No.:	348G-1	Test Date:	2025/06/30
Test Site:	RF	Test Mode:	Transmitting
Tester:	Cheeb Huang	Test Result:	Pass

Environmental Conditions:

Temperature: (°C)	25.1	Relative Humidity: (%)	51	ATM Pressure: (kPa)	101.4
-----------------------------	------	----------------------------------	----	-------------------------------	-------

Test Data:

Mode	Test Frequency (MHz)	Peak Output Power (dBm)	Limit (dBm)	Verdict
DH1	2402	6.20	21.00	Pass
	2441	6.10	21.00	Pass
	2480	6.00	21.00	Pass
2DH1	2402	8.52	21.00	Pass
	2441	8.43	21.00	Pass
	2480	8.42	21.00	Pass
3DH1	2402	8.93	21.00	Pass
	2441	8.87	21.00	Pass
	2480	8.84	21.00	Pass

DH1_Low

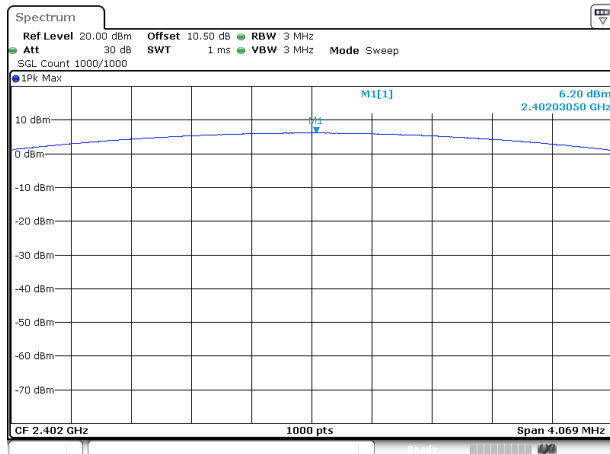

ProjectNo.:2501U29284E-RF Tester:Cheeb Huang
Date: 30 JUN 2025 15:14:53

DH1_Middle

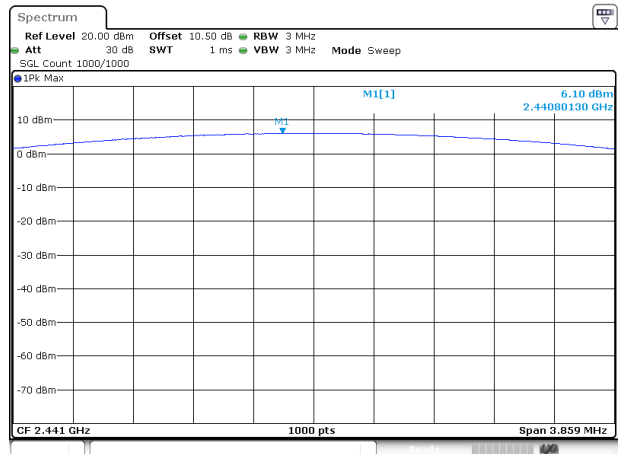

ProjectNo.:2501U29284E-RF Tester:Cheeb Huang
Date: 30 JUN 2025 15:22:47

DH1_High

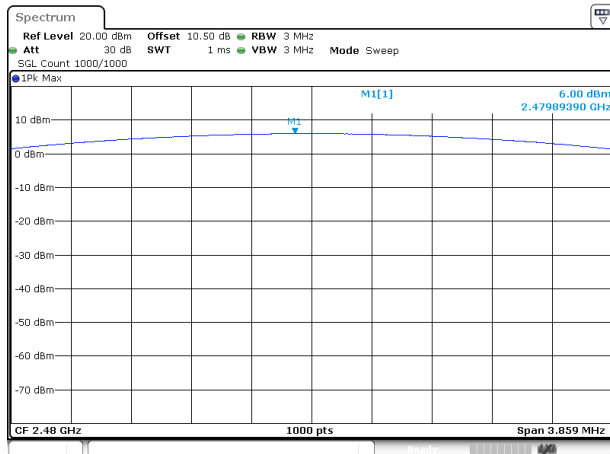

ProjectNo.:2501U29284E-RF Tester:Cheeb Huang
Date: 30 JUN 2025 15:24:44

2DH1_Low

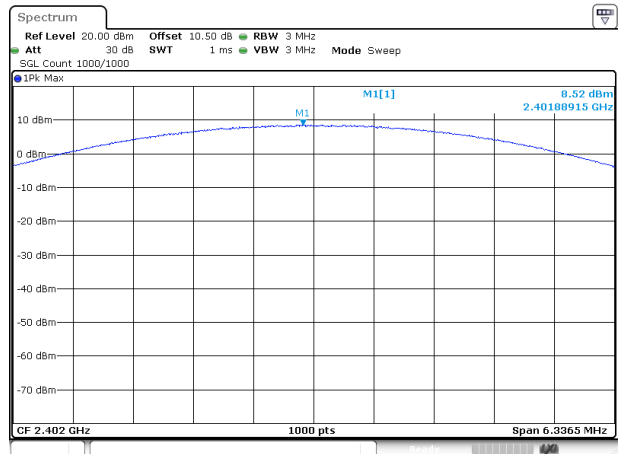

ProjectNo.:2501U29284E-RF Tester:Cheeb Huang
Date: 30 JUN 2025 15:31:50

2DH1_Middle

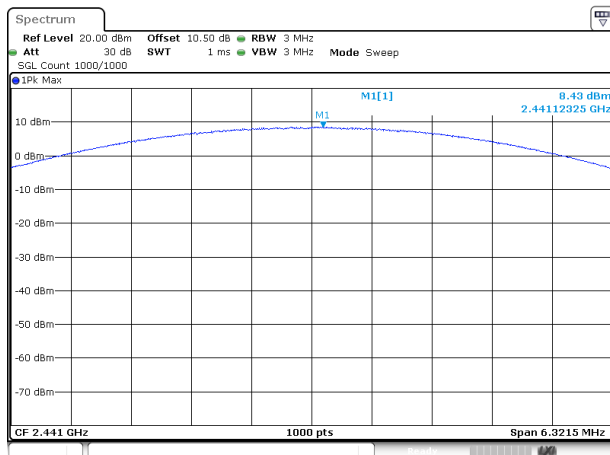

ProjectNo.:2501U29284E-RF Tester:Cheeb Huang
Date: 30 JUN 2025 15:32:54

2DH1_High

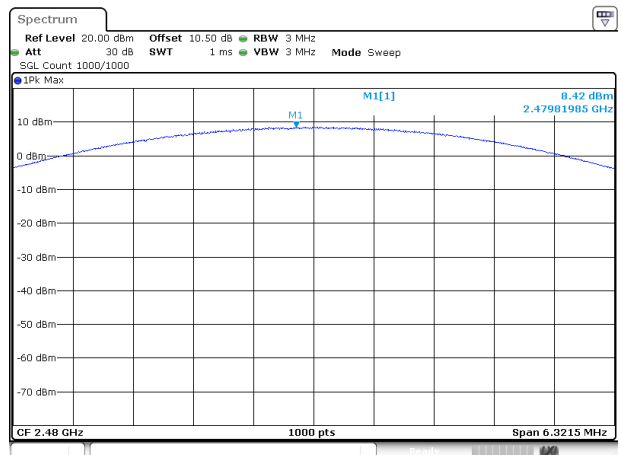

ProjectNo.:2501U29284E-RF Tester:Cheeb Huang
Date: 30 JUN 2025 15:33:50

3DH1_Low

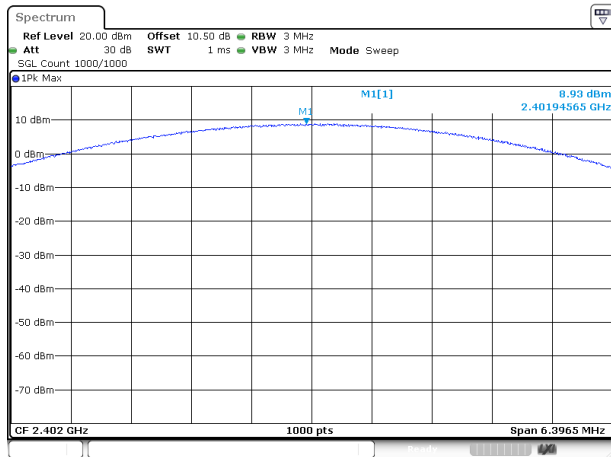

ProjectNo.:2501U29284E-RF Tester:Cheeb Huang
Date: 30 JUN 2025 15:34:47

3DH1_Middle

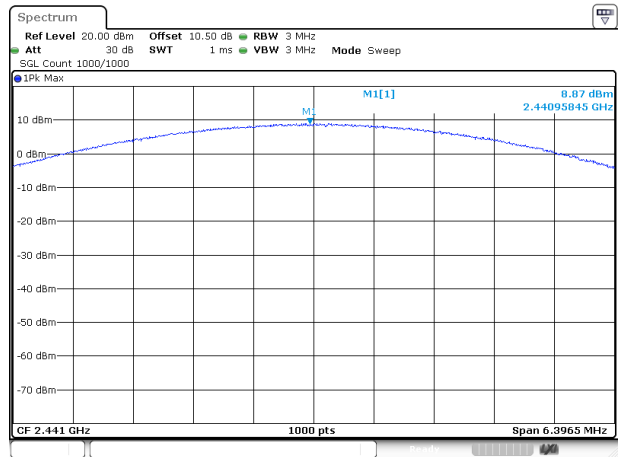

ProjectNo.:2501U29284E-RF Tester:Cheeb Huang
Date: 30 JUN 2025 15:35:46

3DH1_High

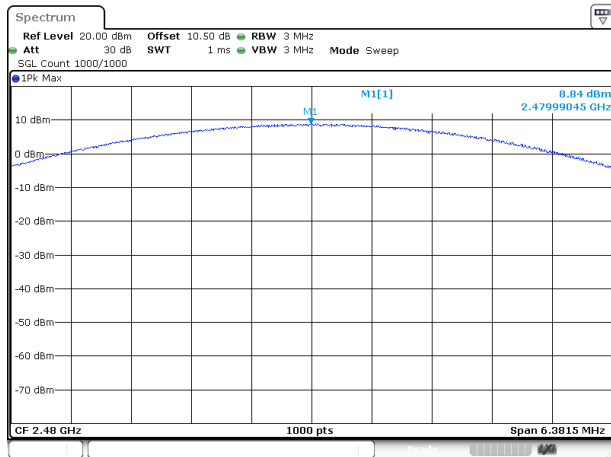

ProjectNo.:2501U29284E-RF Tester:Cheeb Huang
Date: 30 JUN 2025 15:36:57

100 kHz Bandwidth of Frequency Band Edge**Test Information:**

Sample No.:	348G-1	Test Date:	2025/06/30
Test Site:	RF	Test Mode:	Transmitting
Tester:	Cheeb Huang	Test Result:	Pass

Environmental Conditions:

Temperature: (°C)	25.1	Relative Humidity: (%)	51	ATM Pressure: (kPa)	101.4
-----------------------------	------	----------------------------------	----	-------------------------------	-------

Test Data:

DH1_Low

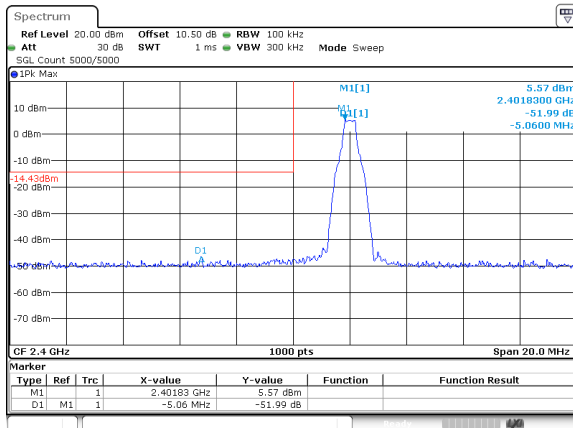

ProjectNo.:2501U29284E-RF Tester:Cheeb Huang
Date: 30 JUN 2025 15:57:40

DH1_High

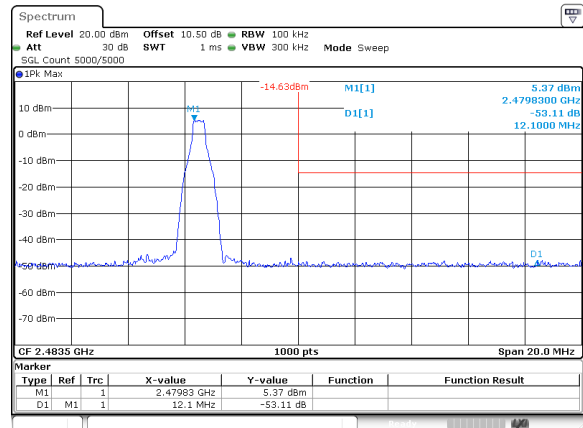

ProjectNo.:2501U29284E-RF Tester:Cheeb Huang
Date: 30 JUN 2025 16:10:37

DH1_Hopping_Lower

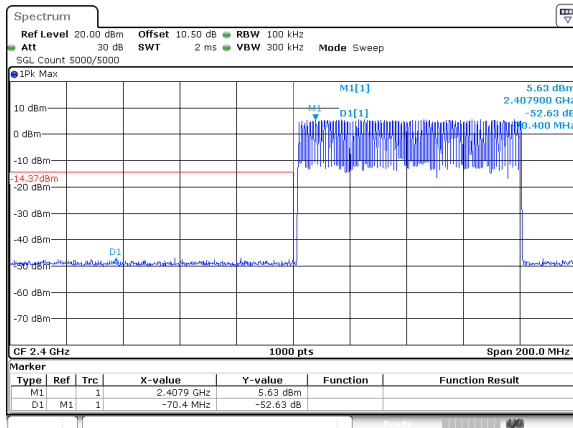

ProjectNo.:2501U29284E-RF Tester:Cheeb Huang
Date: 30 JUN 2025 15:41:34

DH1_Hopping_Upper

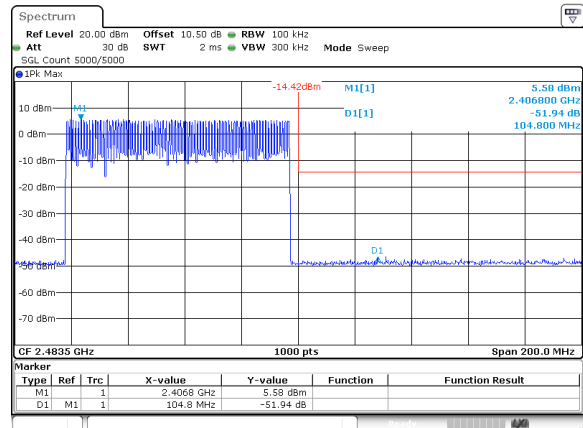

ProjectNo.:2501U29284E-RF Tester:Cheeb Huang
Date: 30 JUN 2025 15:42:57

2DH1_Low

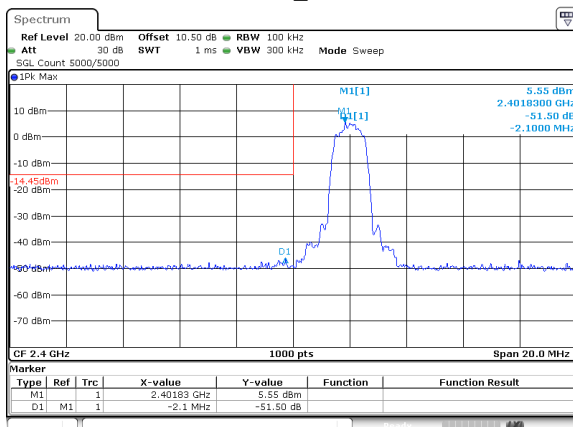

ProjectNo.:2501U29284E-RF Tester:Cheeb Huang
Date: 30 JUN 2025 16:13:47

2DH1_High

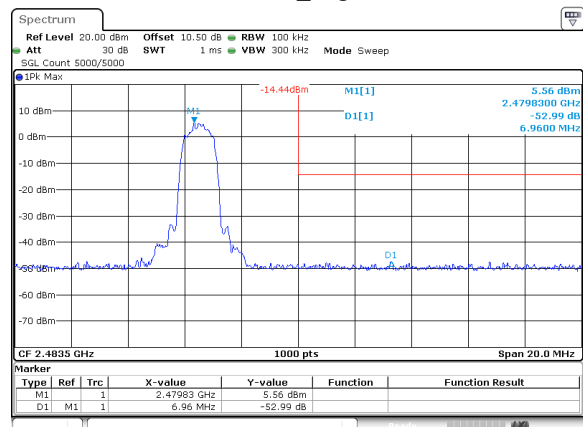

ProjectNo.:2501U29284E-RF Tester:Cheeb Huang
Date: 30 JUN 2025 16:16:09

2DH1_Hopping_Lower

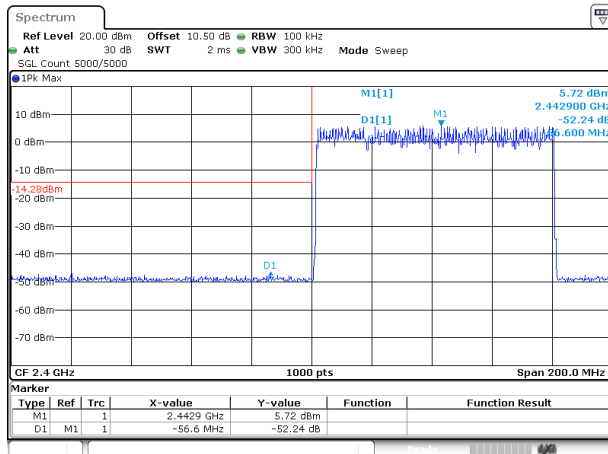

ProjectNo.:2501U29284E-RF Tester:Cheeb Huang
Date: 30 JUN 2025 15:44:53

2DH1_Hopping_Upper

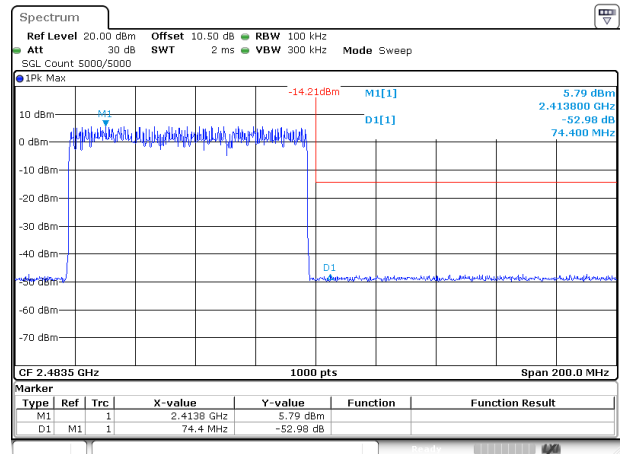

ProjectNo.:2501U29284E-RF Tester:Cheeb Huang
Date: 30 JUN 2025 15:46:17

3DH1_Low

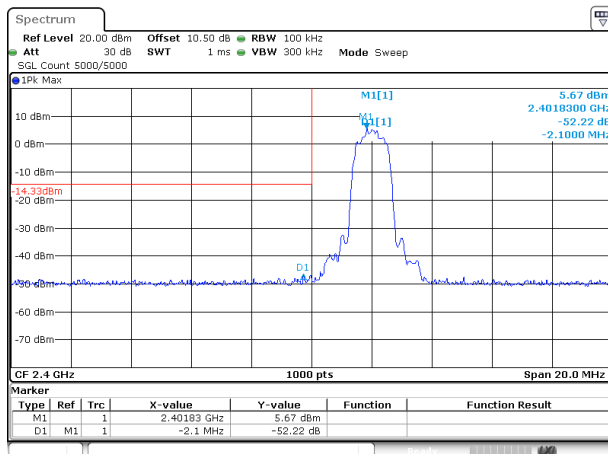

ProjectNo.:2501U29284E-RF Tester:Cheeb Huang
Date: 30 JUN 2025 16:19:11

3DH1_High

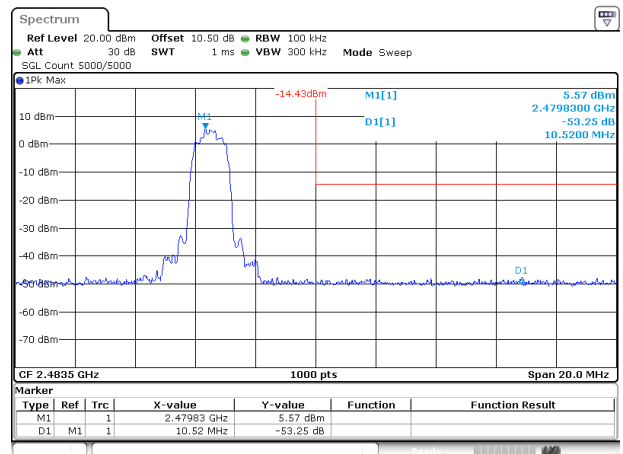

ProjectNo.:2501U29284E-RF Tester:Cheeb Huang
Date: 30 JUN 2025 16:21:52

3DH1_Hopping_Lower

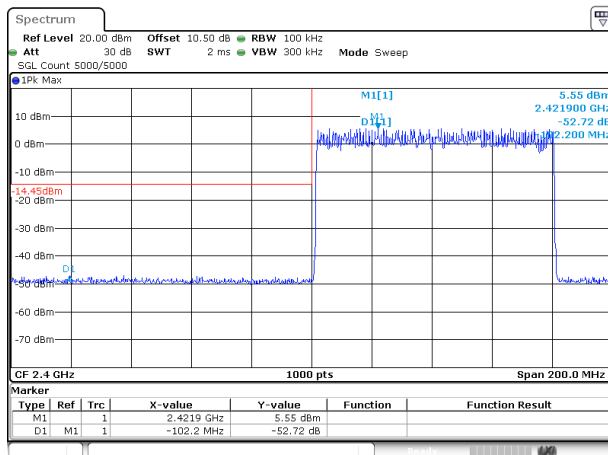

ProjectNo.:2501U29284E-RF Tester:Cheeb Huang
Date: 30 JUN 2025 15:48:26

3DH1_Hopping_Upper

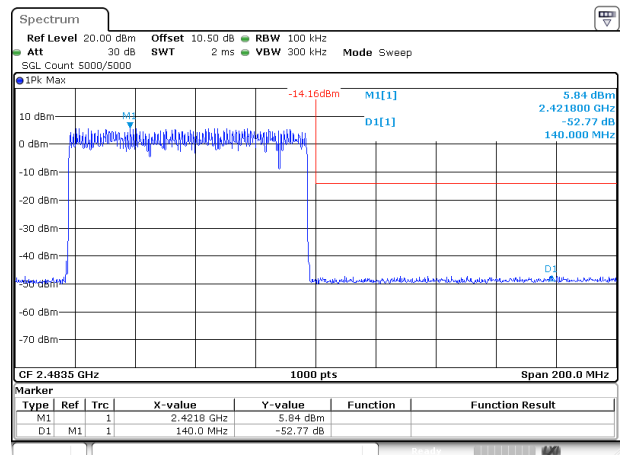

ProjectNo.:2501U29284E-RF Tester:Cheeb Huang
Date: 30 JUN 2025 15:53:39

Time of Occupancy (dwell time)

Test Information:

Sample No.:	348G-1	Test Date:	2025/06/30
Test Site:	RF	Test Mode:	Transmitting
Tester:	Cheeb Huang	Test Result:	Pass

Environmental Conditions:

Temperature: (°C)	25.1	Relative Humidity: (%)	51	ATM Pressure: (kPa)	101.4
-----------------------------	------	----------------------------------	----	-------------------------------	-------

Test Data:

Mode	Channel	Pulse width (ms)	Dwell time (s)	Limit (s)	Verdict
DH1	Hopping Channel	0.394	0.126	0.400	Pass
DH3	Hopping Channel	1.652	0.264	0.400	Pass
DH5	Hopping Channel	2.903	0.310	0.400	Pass
2DH1	Hopping Channel	0.398	0.127	0.400	Pass
2DH3	Hopping Channel	1.655	0.265	0.400	Pass
2DH5	Hopping Channel	2.898	0.309	0.400	Pass
3DH1	Hopping Channel	0.399	0.128	0.400	Pass
3DH3	Hopping Channel	1.655	0.265	0.400	Pass
3DH5	Hopping Channel	2.913	0.311	0.400	Pass

Note:

DH1:Dwell time=Pulse width (ms) × (1600/2/79) ×31.6 s

DH3:Dwell time=Pulse width (ms) × (1600/4/79) ×31.6 s

DH5:Dwell time=Pulse width (ms) × (1600/6/79) ×31.6 s

2DH1: Dwell time=Pulse width (ms) × (1600/2/79) ×31.6 s

2DH3: Dwell time=Pulse width (ms) × (1600/4/79) ×31.6 s

2DH5: Dwell time=Pulse width (ms) × (1600/6/79) ×31.6 s

3DH1: Dwell time=Pulse width (ms) × (1600/2/79) ×31.6 s

3DH3: Dwell time=Pulse width (ms) × (1600/4/79) ×31.6 s

3DH5: Dwell time=Pulse width (ms) × (1600/6/79) ×31.6 s

DH1_Hopping

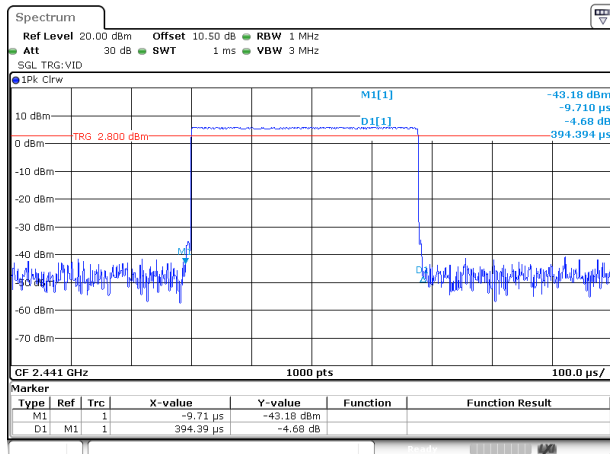

ProjectNo.:2501U29284E-RF Tester:Cheeb Huang
Date: 30 JUN 2025 16:28:58

DH3_Hopping

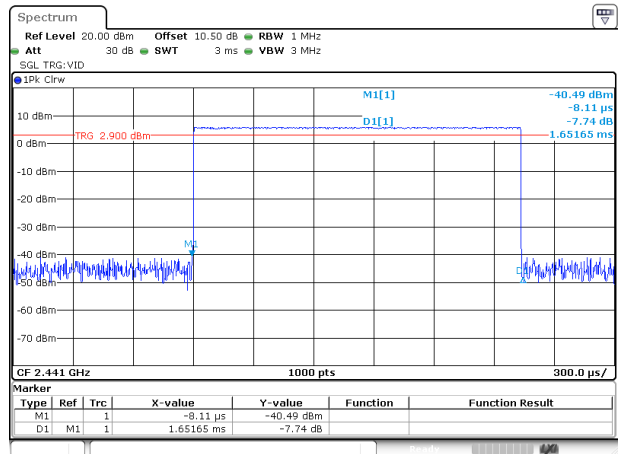

ProjectNo.:2501U29284E-RF Tester:Cheeb Huang
Date: 30 JUN 2025 16:29:38

DH5_Hopping

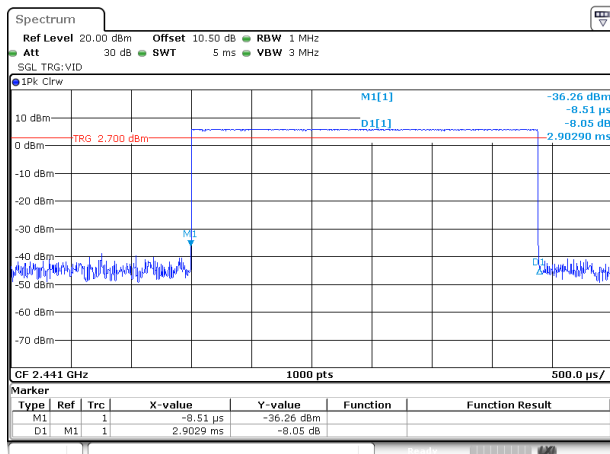

ProjectNo.:2501U29284E-RF Tester:Cheeb Huang
Date: 30 JUN 2025 16:30:16

2DH1_Hopping

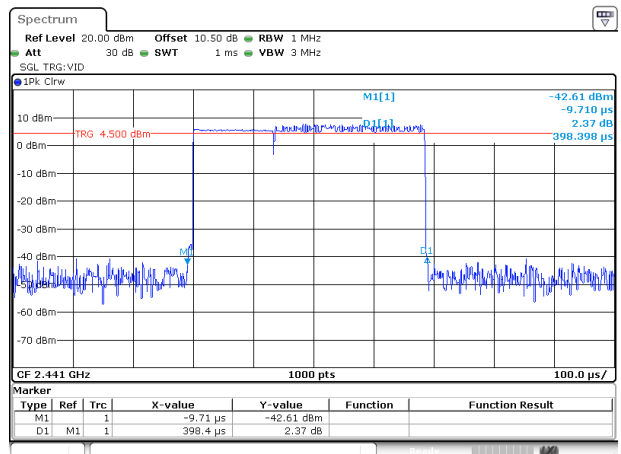

ProjectNo.:2501U29284E-RF Tester:Cheeb Huang
Date: 30 JUN 2025 16:32:58

2DH3_Hopping

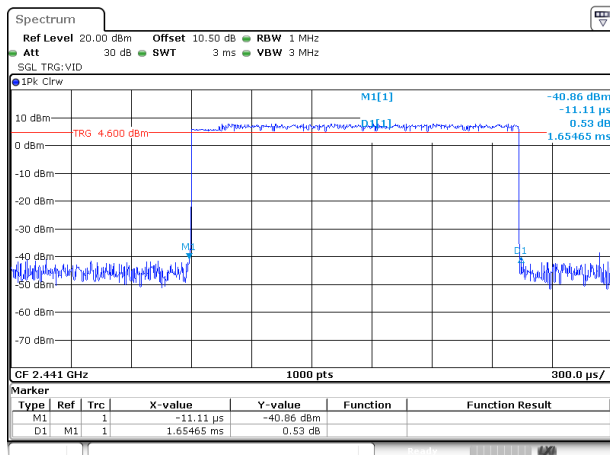

ProjectNo.:2501U29284E-RF Tester:Cheeb Huang
Date: 30 JUN 2025 16:33:51

2DH5_Hopping

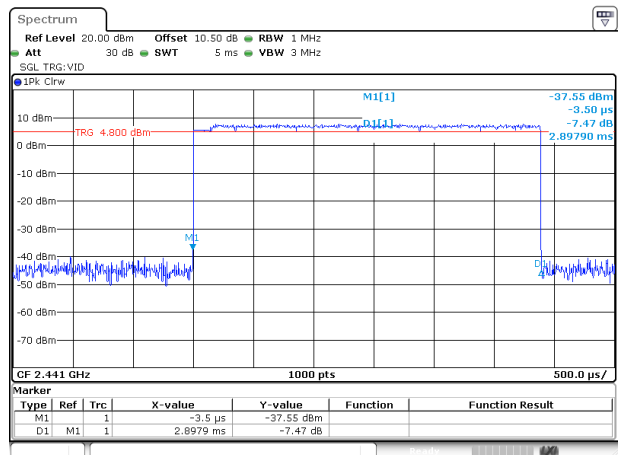

ProjectNo.:2501U29284E-RF Tester:Cheeb Huang
Date: 30 JUN 2025 16:34:47

3DH1_Hopping

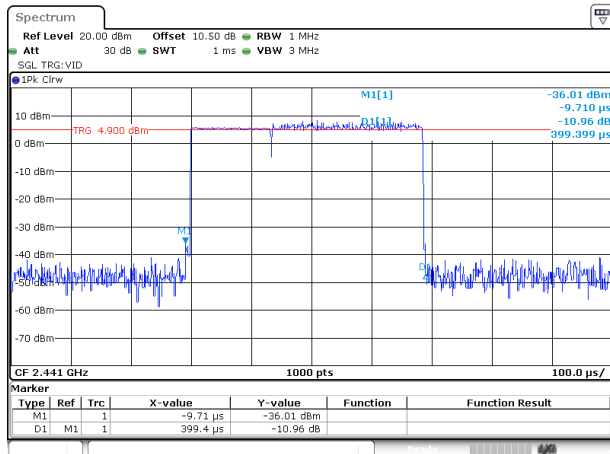

ProjectNo.:2501U29284E-RF Tester:Cheeb Huang
 Date: 30 JUN 2025 16:35:38

3DH3_Hopping

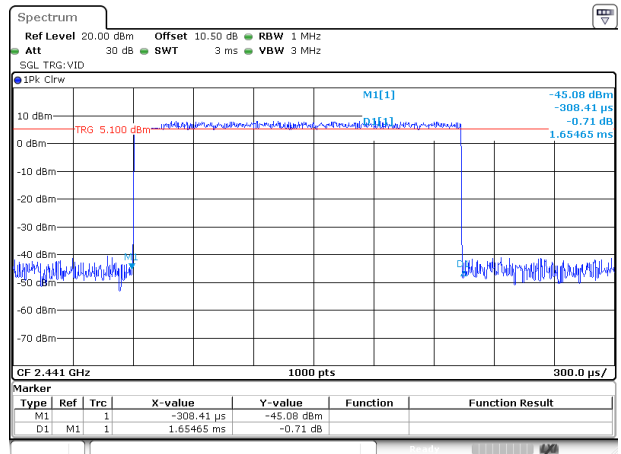

ProjectNo.:2501U29284E-RF Tester:Cheeb Huang
 Date: 30 JUN 2025 16:36:31

3DH5_Hopping

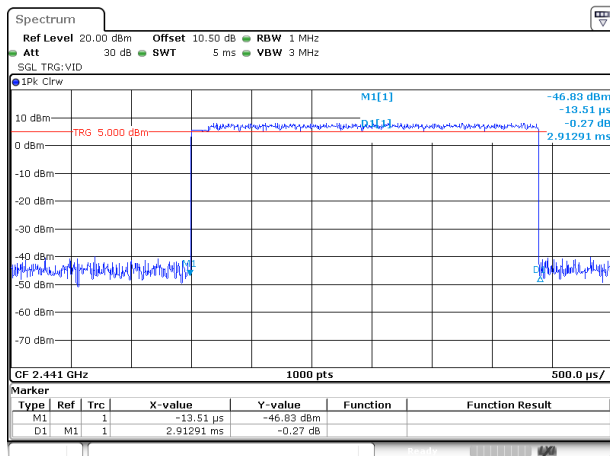

ProjectNo.:2501U29284E-RF Tester:Cheeb Huang
 Date: 30 JUN 2025 16:38:07

RF EXPOSURE EVALUATION

MAXIMUM PERMISSIBLE EXPOSURE (MPE)

Applicable Standard

According to subpart §1.1310, systems operating under the provisions of this section shall be operated in a manner that ensures that the public is not exposed to radio frequency energy level in excess of the Commission’s guidelines.

Limits for Maximum Permissible Exposure (MPE) (§1.1310, §2.1091)

(B) Limits for General Population/Uncontrolled Exposure				
Frequency Range (MHz)	Electric Field Strength (V/m)	Magnetic Field Strength (A/m)	Power Density (mW/cm²)	Averaging Time (minutes)
0.3–1.34	614	1.63	*(100)	30
1.34–30	824/f	2.19/f	*(180/f ²)	30
30–300	27.5	0.073	0.2	30
300–1500	/	/	f/1500	30
1500–100,000	/	/	1.0	30

f = frequency in MHz; * = Plane-wave equivalent power density;

According to §1.1310 and §2.1091 RF exposure is calculated.

Result

Calculation formula:

Prediction of power density at the distance of the applicable MPE limit

S = PG/4πR² = power density (in appropriate units, e.g. mW/cm²);

P = power input to the antenna (in appropriate units, e.g., mW);

G = power gain of the antenna in the direction of interest relative to an isotropic radiator, the power gain factor, is normally numeric gain;

R = distance to the center of radiation of the antenna (appropriate units, e.g., cm);

For simultaneously transmit system, the calculated power density should comply with:

$$\sum_i \frac{S_i}{S_{Limit,i}} \leq 1$$

Calculated Data:

For worst case:

Mode	Frequency (MHz)	Antenna Gain [#]		Max Tune-up Power [#]		Evaluation Distance (cm)	Power Density (mW/cm ²)	MPE Limit (mW/cm ²)
		(dBi)	(numeric)	(dBm)	(mW)			
BT	2402-2480	2.64	1.84	9.0	7.94	20	0.0029	1.0
BLE	2402-2480	2.64	1.84	2.5	1.78	20	0.0007	1.0
2.4G Wi-Fi	2412-2462	5.83	3.83	25.5	354.81	20	0.2703	1.0
5G Wi-Fi	5150-5250	5.67	3.69	18.0	63.10	20	0.0463	1.0
	5725-5850	5.18	3.30	19.0	79.43	20	0.0521	1.0

Note:

- 1) The tune up conducted power and antenna gain was declared by the applicant.
- 2) For the Wi-Fi mode, the antenna gain should be the directional gain.
- 3) The BT and Wi-Fi can transmit at same time, the 2.4G and 5G Wi-Fi cannot transmit at same time.

Simultaneous transmitting consideration (worst case):

$$\text{The ratio} = \text{MPE}_{\text{BT}}/\text{limit} + \text{MPE}_{\text{2.4G Wi-Fi}}/\text{limit} = 0.0029/1.0 + 0.2703/1.0 = 0.273 < 1.0$$

So simultaneous exposure is compliant.

To maintain compliance with the FCC's RF exposure guidelines, place the equipment at least 20cm from nearby persons.

Result: Compliant.

EUT PHOTOGRAPHS

Please refer to the attachment 2501U29284E-RF External photo and 2501U29284E-RF Internal photo.

TEST SETUP PHOTOGRAPHS

Please refer to the attachment 2501U29284E-RF-00A Test Setup photo.

******* END OF REPORT *******