



# RF TEST REPORT

Product Name: Wearable Breast Pump

Model Name: W2

FCC ID: 2BDXG-W2

IC: 34091-W2

Issued For : Shenzhen TPH Technology Co.,LTD.

Room 203,2nd floor,29th Building, Lianchuang Technology  
Park, No. 21 Bulan Road,Xialilang Community,Nanwan  
Street,Longgang District,Shenzhen,China

Issued By : Shenzhen LGT Test Service Co., Ltd.

Room 205, Building 13, Zone B, Zhenxiong Industrial Park,  
No.177, Renmin West Road, Jinsha, Kengzi Street, Pingshan  
District, Shenzhen, Guangdong, China

Report Number: LGT25E162RF01

Sample Received Date: May 29, 2025

Date of Test: May 29, 2025 ~ June 11, 2025

Date of Issue: June 11, 2025

The test report is effective only with both signature and specialized stamp. This report shall not be reproduced except in full without the written approval of the Laboratory. The results in this report only apply to the tested sample.



# TEST REPORT CERTIFICATION

**Applicant:** Shenzhen TPH Technology Co.,LTD.  
 Room 203,2nd floor,29th Building, Lianchuang Technology Park, No. 21  
**Address:** Bulan Road,Xialilang Community,Nanwan Street,Longgang  
 District,Shenzhen,China

**Manufacturer:** Shenzhen TPH Technology Co.,LTD.  
 Room 203,2nd floor,29th Building, Lianchuang Technology Park, No. 21  
**Address:** Bulan Road,Xialilang Community,Nanwan Street,Longgang  
 District,Shenzhen,China

**Product Name:** Wearable Breast Pump

**Trademark:** N/A

**Model Name:** W2

**Sample Status:** Normal

**Serial Number:** LGT2505177-1

APPLICABLE STANDARDS	
STANDARD	TEST RESULTS
FCC Part 15.247, Subpart C RSS-247 Issue 3, August 2023 RSS-Gen Issue 5, February 2021 ANSI C63.10-2013	PASS

Prepared by:

Zane Shan

Zane Shan  
Engineer

Approved by:

Vita Li

Vita Li  
Technical Director





<b>Table of Contents</b>	<b>Page</b>
<b>1. SUMMARY OF TEST RESULTS</b>	<b>6</b>
1.1 TEST FACTORY	7
1.2 MEASUREMENT UNCERTAINTY	7
<b>2. GENERAL INFORMATION</b>	<b>8</b>
2.1 GENERAL DESCRIPTION OF THE EUT	8
2.2 DESCRIPTION OF THE TEST MODES	9
2.3 TEST SOFTWARE AND POWER LEVEL	9
2.4 DESCRIPTION OF NECESSARY ACCESSORIES AND SUPPORT UNITS	10
2.5 BLOCK DIGRAM SHOWING THE CONFIGURATION OF SYSTEM TESTED	11
2.6 EQUIPMENTS LIST	13
<b>3. EMC EMISSION TEST</b>	<b>15</b>
3.1 CONDUCTED EMISSION MEASUREMENT	15
3.2 TEST PROCEDURE	16
3.3 TEST SETUP	16
3.4 EUT OPERATING CONDITIONS	16
3.5 TEST RESULTS	17
<b>4. RADIATED EMISSION MEASUREMENT</b>	<b>19</b>
4.1 RADIATED EMISSION LIMITS	19
4.2 TEST PROCEDURE	21
4.3 TEST SETUP	22
4.4 EUT OPERATING CONDITIONS	22
4.5 FIELD STRENGTH CALCULATION	23
4.6 TEST RESULTS	24
4.7 TEST RESULTS (BAND EDGE REQUIREMENTS)	28
<b>5. CONDUCTED SPURIOUS &amp; BAND EDGE EMISSION</b>	<b>29</b>
5.1 LIMIT	29
5.2 TEST PROCEDURE	29
5.3 TEST SETUP	29
5.4 EUT OPERATION CONDITIONS	29
5.5 TEST RESULTS	29
<b>6. POWER SPECTRAL DENSITY TEST</b>	<b>30</b>
6.1 LIMIT	30
6.2 TEST PROCEDURE	30



6.3 TEST SETUP	30
6.4 EUT OPERATION CONDITIONS	30
6.5 TEST RESULTS	30
<b>7. BANDWIDTH TEST</b>	<b>31</b>
7.1 LIMIT	31
7.2 TEST PROCEDURE	31
7.3 TEST SETUP	31
7.4 EUT OPERATION CONDITIONS	31
7.5 TEST RESULTS	31
<b>8. PEAK OUTPUT POWER TEST</b>	<b>32</b>
8.1 LIMIT	32
8.2 TEST PROCEDURE	32
8.3 TEST SETUP	错误!未定义书签。
8.4 EUT OPERATION CONDITIONS	32
8.5 TEST RESULTS	32
<b>9. ANTENNA REQUIREMENT</b>	<b>33</b>
9.1 STANDARD REQUIREMENT	33
9.2 EUT ANTENNA	33
<b>10. FREQUENCY STABILITY</b>	<b>34</b>
10.1 LIMITS OF FREQUENCY STABILITY MEASUREMENT	34
10.2 TEST PROCEDURE	34
10.3 TEST RESULT	34
<b>APPENDIX I - TEST RESULTS</b>	<b>35</b>
ANNEX A. OUTPUT POWER	35
ANNEX A. 6DB BANDWIDTH	36
ANNEX A. 99% BANDWIDTH	37
ANNEX A. CONDUCTED SPURIOUS EMISSIONS	38
ANNEX A. BANDEDGE(H)--CSE	41
ANNEX A. BANDEDGE(L)--CSE	42
ANNEX A. POWER SPECTRAL DENSITY (PSD)	43
ANNEX A. DUTY CYCLE	44
FREQUENCY STABILITY	45
<b>APPENDIX II - MEASUREMENT PHOTOS</b>	<b>46</b>



**Revision History**

Rev.	Issue Date	Contents
00	June 11, 2025	Initial Issue



## 1. SUMMARY OF TEST RESULTS

Test procedures according to the technical standards:  
KDB 558074 D01 15.247 Meas Guidance v05r02.

<b>FCC Part 15.247, Subpart C RSS-247 Issue 3</b>			
Standard Section	Test Item	Judgment	Remark
15.207 RSS-Gen 8.8	Conducted Emission	PASS	--
15.247 (a)(2) RSS-Gen 6.7 RSS-247 5.2 (a)	6dB&99% Bandwidth	PASS	--
15.247 (b)(3) RSS-247 5.4 (d)	Output Power	PASS	--
15.209 RSS-Gen 8.9/8.10	Radiated Spurious Emission	PASS	--
15.247 (d) RSS-Gen 8.9/8.10	Conducted Spurious & Band Edge Emission	PASS	--
15.247 (e) RSS-247 5.2 (b)	Power Spectral Density	PASS	--
15.205 RSS-Gen 8.9/8.10	Restricted Band Edge Emission	PASS	--
Part 15.247(d)/ Part 15.209(a) RSS-247 5.5 RSS-Gen 8.9/8.10	Band Edge Emission	PASS	--
15.203 RSS-Gen 6.8	Antenna Requirement	PASS	--
RSS-Gen 6.11/8.11	Frequency Stability	PASS	--

### NOTE:

- (1) 'N/A' denotes test is not applicable in this Test Report.
- (2) All tests are according to ANSI C63.10-2013.



## 1.1 TEST FACTORY

Company Name:	Shenzhen LGT Test Service Co., Ltd.
Address:	Room 205, Building 13, Zone B, Zhenxiong Industrial Park, No.177, Renmin West Road, Jinsha, Kengzi Street, Pingshan District, Shenzhen, Guangdong, China
Accreditation Certificate:	A2LA Certificate No.: 6727.01
	FCC Registration No.: 746540
	CAB ID: CN0136

## 1.2 MEASUREMENT UNCERTAINTY

The reported uncertainty of measurement  $y \pm U$ , where expanded uncertainty  $U$  is based on a standard uncertainty multiplied by a coverage factor of  $k=2$ , providing a level of confidence of approximately **95** %.

No.	Item	Uncertainty
1	Occupied Channel Bandwidth	$\pm 0.46\%$
2	RF Output Power, Conducted	$\pm 0.71\text{dB}$
3	Power Spectral Density, Conducted	$\pm 1.57\text{dB}$
4	Unwanted Emission, Conducted	$\pm 0.63\text{dB}$
5	Conducted emission	$\pm 2.80\text{dB}$
6	All Emissions, Radiated (0.009-30MHz)	$\pm 2.16\text{dB}$
7	All Emissions, Radiated (30MHz-1GHz)	$\pm 4.61\text{dB}$
8	All Emissions, Radiated (1GHz-18GHz)	$\pm 5.49\text{dB}$
9	Temperature	$\pm 0.5^\circ\text{C}$
10	Humidity	$\pm 2\%$
11	Duty Cycle	$\pm 2.3\%$

Note: The measurement uncertainty is not included in the test result.



## 2. GENERAL INFORMATION

### 2.1 GENERAL DESCRIPTION OF THE EUT

Product Name:	Wearable Breast Pump	
Trademark:	N/A	
Model Name:	W2	
Series Model:	N/A	
Model Difference:	N/A	
Product Description:	Operation Frequency:	2402~2480 MHz
	Modulation Type:	GFSK
	Radio Technology:	BLE
	Bluetooth Configuration:	BLE (1M PHY)
	Number Of Channel:	40
	Antenna Type:	PCB Antenna
	Antenna Gain (dBi):	2.54
Channel List:	Please refer to the Note 3.	
Rating:	Input: DC 5V	
Battery:	Capacity: 2000mAh Rated Voltage: 3.7V	
Hardware Version:	N/A	
Software Version:	N/A	
Connecting I/O Port(s):	Please refer to the Note 1.	

Note:

1. For a more detailed features description, please refer to the manufacturer's specifications or the User Manual.
2. The antenna information refers to the manufacturer provide report, applicable only to the tested sample identified in the report. Due to the incorrect antenna information, a series of problems such as the accuracy of the test results will be borne by the customer.





3.

Channel List							
Channel	Frequency (MHz)	Channel	Frequency (MHz)	Channel	Frequency (MHz)	Channel	Frequency (MHz)
00	2402	10	2422	20	2442	30	2462
01	2404	11	2424	21	2444	31	2464
02	2406	12	2426	22	2446	32	2466
03	2408	13	2428	23	2448	33	2468
04	2410	14	2430	24	2450	34	2470
05	2412	15	2432	25	2452	35	2472
06	2414	16	2434	26	2454	36	2474
07	2416	17	2436	27	2456	37	2476
08	2418	18	2438	28	2458	38	2478
09	2420	19	2440	29	2460	39	2480

## 2.2 DESCRIPTION OF THE TEST MODES

For conducted test items and radiated spurious emissions  
Each of these EUT operation mode(s) or test configuration mode(s) mentioned below was evaluated respectively.

Worst Mode	Description	Data/Modulation
Mode 1	TX CH00(2402MHz)	1 MHz/GFSK
Mode 2	TX CH19(2440MHz)	1 MHz/GFSK
Mode 3	TX CH39(2480MHz)	1 MHz/GFSK

Note:

- (1) The measurements are performed at all Bit Rate of Transmitter, the worst data was reported.
- (2) We have be tested for all avaiable U.S. voltage and frequency (For 120V,50/60Hz and 240V, 50/60Hz) for which the device is capable of operation, and the worst case of 120V/60Hz is shown in the report.
- (3) The battery is fully-charged during the radited and RF conducted test.

For AC Conducted Emission

Test Case	
AC Conducted Emission	Mode 4: Keeping BLE TX

## 2.3 TEST SOFTWARE AND POWER LEVEL

During testing channel & power controlling software provided by the customer was used to control the operating channel as well as the output power level.

Test software Version	Test program: BLE	
CMD Command	Mode Or Modulation type	Power setting
	1M	Default



## 2.4 DESCRIPTION OF NECESSARY ACCESSORIES AND SUPPORT UNITS

The EUT has been tested as an independent unit together with other necessary accessories or support units. The following support units or accessories were used to form a representative test configuration during the tests.

### Accessories Equipment

Description	Manufacturer	Model	S/N	Rating
USB-Cable	N/A	N/A	N/A	1m

### Auxiliary Equipment

Description	Manufacturer	Model	S/N	Rating
Laptop	Lenovo	T470s	N/A	N/A
Adapter	Tenpao	S010WU0500200	N/A	Input: 100-240V ~ 50/60Hz 0.4A Output: 5V, 2A

#### Note:

- (1) For detachable type I/O cable should be specified the length in cm in 『Length』 column.
- (2) “YES” is means “with core”; “NO” is means “without core”.



## 2.5 BLOCK DIGRAM SHOWING THE CONFIGURATION OF SYSTEM TESTED

### Block diagram of EUT configuration

Test mode: TX mode

Non-Conductive Table

80 cm above Ground Plane

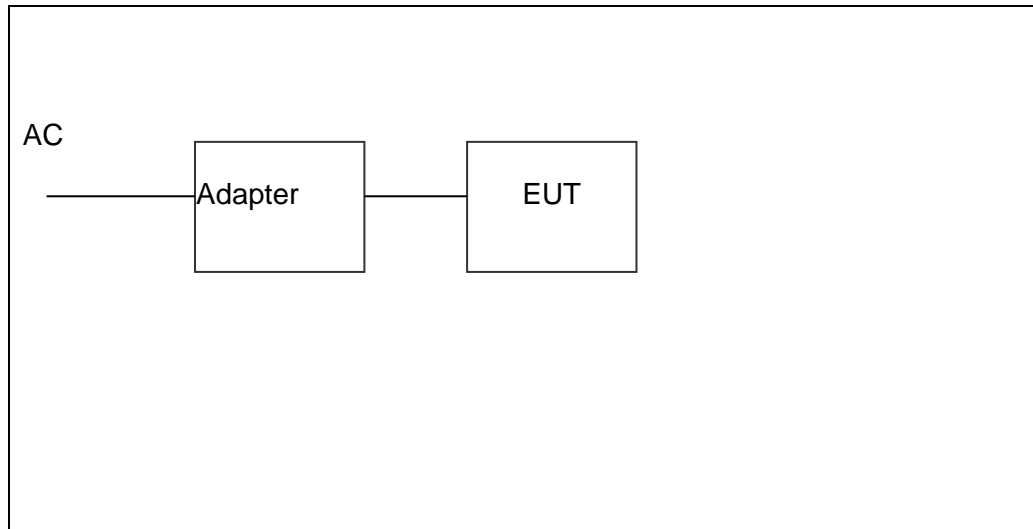

### RF configuration

Test mode: TX

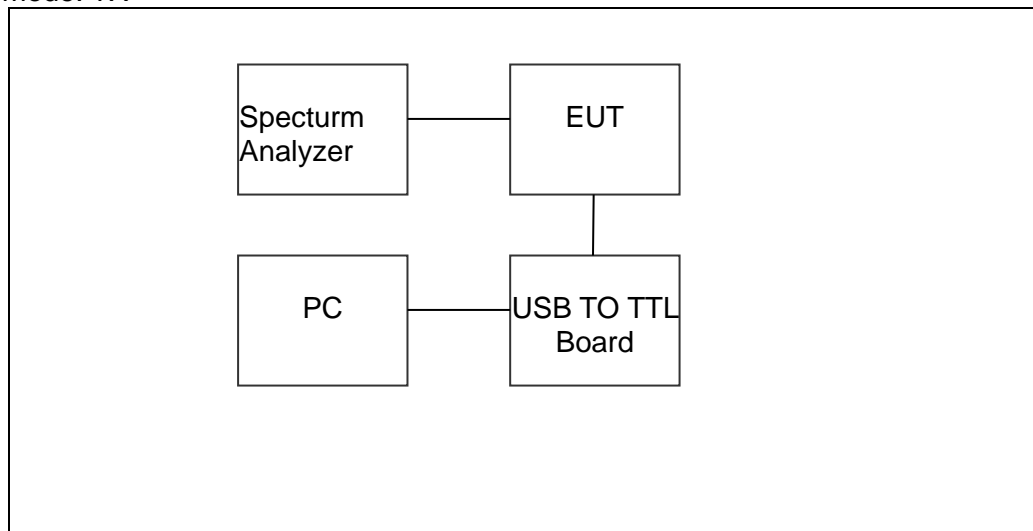



Block diagram of EUT configuration

RADIATED EMISSION

Test mode: TX mode

Non-Conductive Table

80 cm above Ground Plane

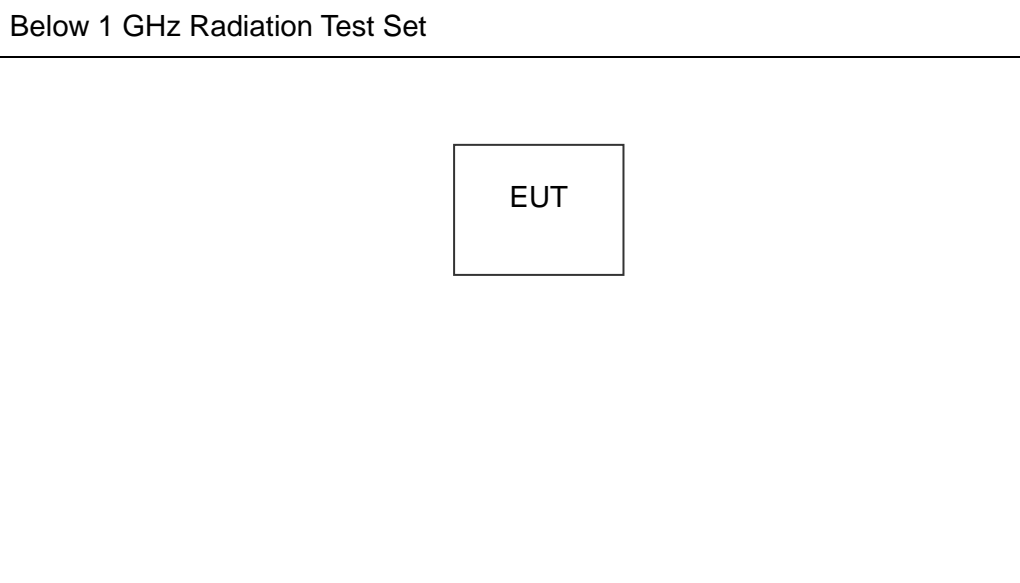

150 cm above Ground Plane

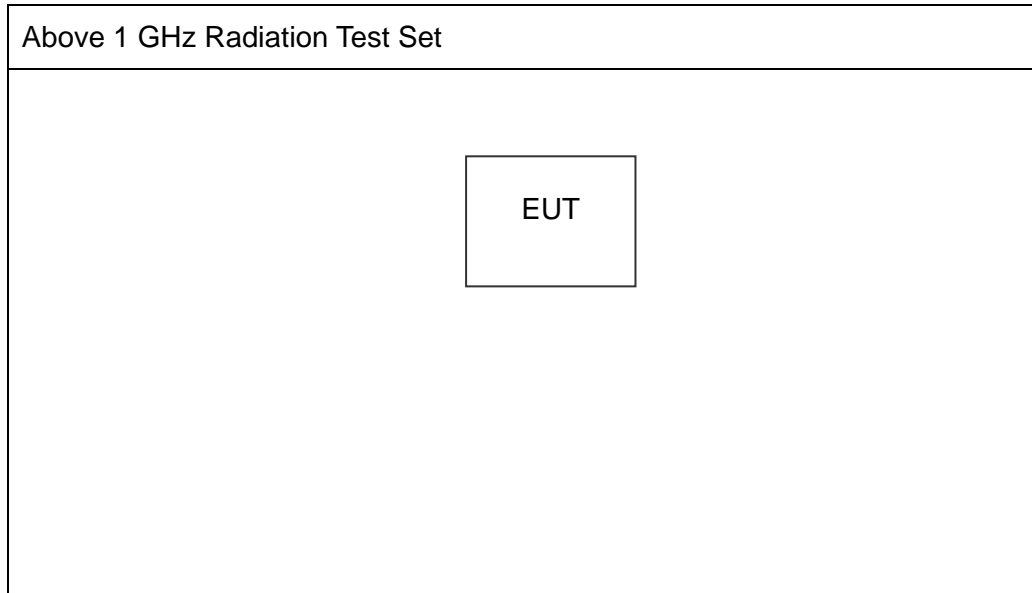



## 2.6 EQUIPMENTS LIST

<b>Conducted Emission</b>					
<b>Equipment</b>	<b>Manufacturer</b>	<b>Model No.</b>	<b>Serial No.</b>	<b>Cal. Date</b>	<b>Cal. Until</b>
EMI Test Receiver	R&S	ESU8	100372	2025.03.06	2026.03.05
LISN	COM-POWER	LI-115	02032	2025.03.05	2026.03.04
LISN	SCHWARZBECK	NNLK 8122	00160	2025.03.05	2026.03.04
Transient Limiter	CYBERTEK	EM5010A	E2250100049	2025.03.05	2026.03.04
Coaxial cables (9kHz-30MHz)	Juncoax	JMR600-NMNM-2M	N.A	2025.03.06	2026.03.05
Temperature & Humidity	JINGCHUANG	BT-3	N.A	2025.03.10	2026.03.09
Testing Software	EMC-I_V1.4.0.3_SKET				

<b>Radiated Test equipment</b>					
<b>Equipment</b>	<b>Manufacturer</b>	<b>Model No.</b>	<b>Serial No.</b>	<b>Cal. Date</b>	<b>Cal. Until</b>
EMI Test Receiver	R&S	ESU8	100372	2025.03.06	2026.03.05
Active loop Antenna	ETS	6502	00049544	2025.03.11	2028.03.10
Spectrum Analyzer	Keysight	N9010B	MY60242508	2025.03.05	2026.03.04
Trilog Broadband Antenna (30M-1G)	SCHWARZBECK	VULB 9168	2705	2024.05.17	2027.05.16
Horn Antenna(1-18G)	SCHWARZBECK	3115	10SL0060	2025.03.10	2028.03.09
Horn Antenna(18-40G)	SCHWARZBECK	BBHA 9170	685	2023.10.23	2026.10.22
Pre-amplifier(30M-1G)	EMtrace	RP01A	02019	2025.03.06	2026.03.05
Pre-amplifier(1-26.5G)	Agilent	8449B	3008A4722	2025.03.06	2026.03.05
Pre-amplifier(18-40G)	SCHWARZBECK	BBV 9721	9721-019	2024.10.21	2025.10.20
Coaxial cables (9kHz-1GHz)	Juncoax	JMR600 -NMNM-8M	N.A	2025.03.06	2026.03.05
Coaxial cables (1GHz-18GHz)	TaiHe	UCD460B -NMSM-1M9	N.A	2025.03.06	2026.03.05
Coaxial cables (18GHz-40GHz)	Junkosha Inc.	MWX241 -05000KMSKMS	N.A	2025.03.08	2026.03.07
Temperature& Humidity test chamber	AISRY	LX-1000L	171200018	2024.08.05	2025.08.04
Antenna Tower	SAEMC	BK-4AT-BS-D	SK2021093008	N.A	N.A
Temperature & Humidity	JINGCHUANG	BT-3	N.A	2025.03.10	2026.03.09
Testing Software	EMC-I_V1.4.0.3_SKET				

<b>RF Conducted Test equipment</b>					
<b>Equipment</b>	<b>Manufacturer</b>	<b>Model No.</b>	<b>Serial No.</b>	<b>Cal. Date</b>	<b>Cal. Until</b>
Signal Analyzer	Keysight	N9010B	MY60242508	2025.03.05	2026.03.04
Signal Analyzer	Keysight	N9020A	MY50530994	2025.03.05	2026.03.04
Signal Analyzer	R&S	FSV40-N	102245	2025.02.17	2026.02.16
Power Sensor	R&S	NRP8S	149.0006K02 -104963-Ae	2025.03.06	2026.03.05
RF Automatic Test system	BALUN	SU319	LW-SZ24D0001A01/02	2025.04.09	2026.04.08
MXG Vector Signal Generator	Keysight	N5182B	MY59100717	2025.03.05	2026.03.04
Temperature& Humidity test chamber	AISRY	LX-1000L	171200018	2024.08.05	2025.08.04



Attenuator	eastsheep	90db	N.A	2025.03.06	2026.03.05
Temperature & Humidity	JINGCHUANG	BT-3	N.A	2025.03.10	2026.03.09
Digital multimeter	MASTECH	MS8261	MBGBC83053	2025.03.05	2026.03.04
DC source	Jiuyuan	QJ6010E	N.A	2025.03.09	2026.03.08
Testing Software	BL410R_3.5.2.605				



### 3. EMC EMISSION TEST

#### 3.1 CONDUCTED EMISSION MEASUREMENT

##### 3.1.1 POWER LINE CONDUCTED EMISSION LIMITS

The radio frequency voltage that is conducted back onto the AC power line on any frequency or frequencies, within the band 150 kHz to 30 MHz, shall not exceed the limits in the following table.

FREQUENCY (MHz)	Conducted Emission limit (dBuV)	
	Quasi-peak	Average
0.15 -0.5	66 - 56 *	56 - 46 *
0.50 -5.0	56.00	46.00
5.0 -30.0	60.00	50.00

Note:

- (1) The tighter limit applies at the band edges.
- (2) The limit of “ \* ” marked band means the limitation decreases linearly with the logarithm of the frequency in the range.

The following table is the setting of the receiver

Receiver Parameters	Setting
Attenuation	10 dB
Start Frequency	0.15 MHz
Stop Frequency	30 MHz
IF Bandwidth	9 kHz



### 3.2 TEST PROCEDURE

- a. The EUT is 0.8 m from the horizontal ground plane and 0.4 m from the vertical ground plane with EUT being connected to the power mains through a line impedance stabilization network (LISN). All other support equipments are powered from additional LISN(s). The LISN provides 50 Ohm/ 50uH of coupling impedance for the measuring instrument.
- b. Interconnecting cables that hang closer than 40 cm to the ground plane shall be folded back and forth in the center forming a bundle 30 to 40 cm long.
- c. I/O cables that are not connected to a peripheral shall be bundled in the center. The end of the cable may be terminated, if required, using the correct terminating impedance. The overall length shall not exceed 1 m.
- d. LISN is at least 80 cm from the nearest part of EUT chassis.
- e. For the actual test configuration, please refer to the related Item –EUT Test Photos.

### 3.3 TEST SETUP

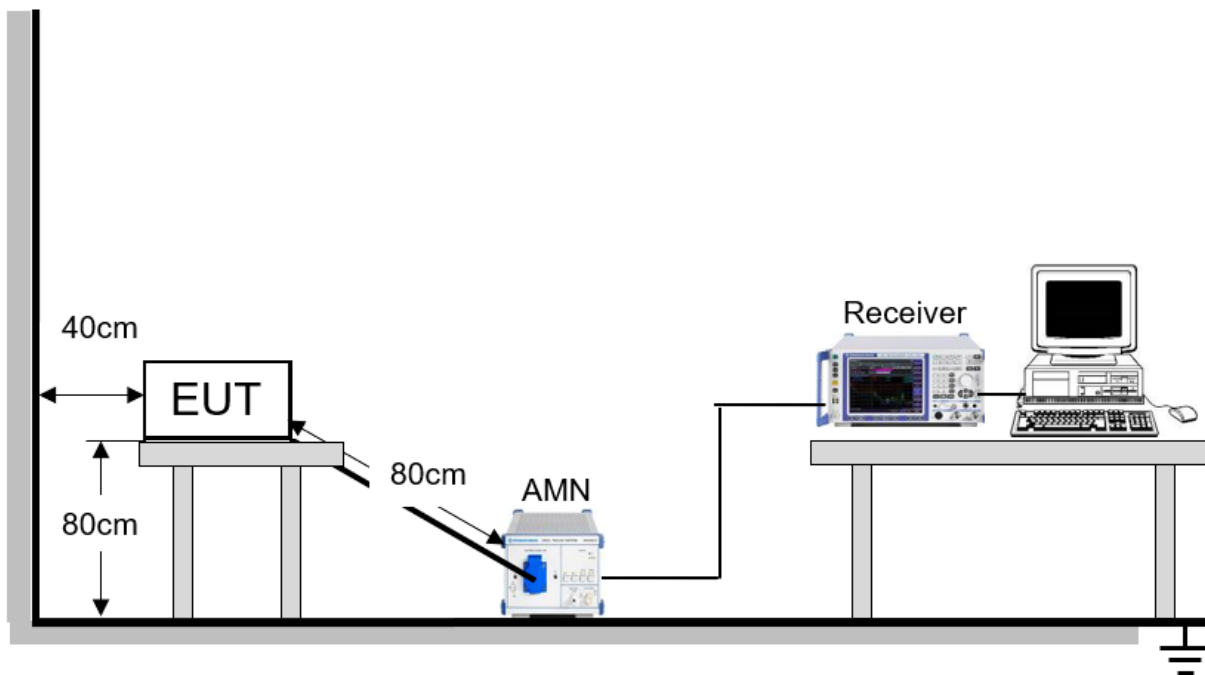

### 3.4 EUT OPERATING CONDITIONS

The EUT was configured for testing in a typical fashion (as a customer would normally use it). The EUT has been programmed to continuously transmit during test. This operating condition was tested and used to collect the included data.





### 3.5 TEST RESULTS

Project: LGT25E162	Test Engineer: LiuH
EUT: Wearable Breast Pump	Temperature: 24.9°C
M/N: W2	Humidity: 52%RH
Test Voltage: AC 120V/60Hz	Test Data: 2025-05-30
Test Mode: TX BLE 2402	
Note:	

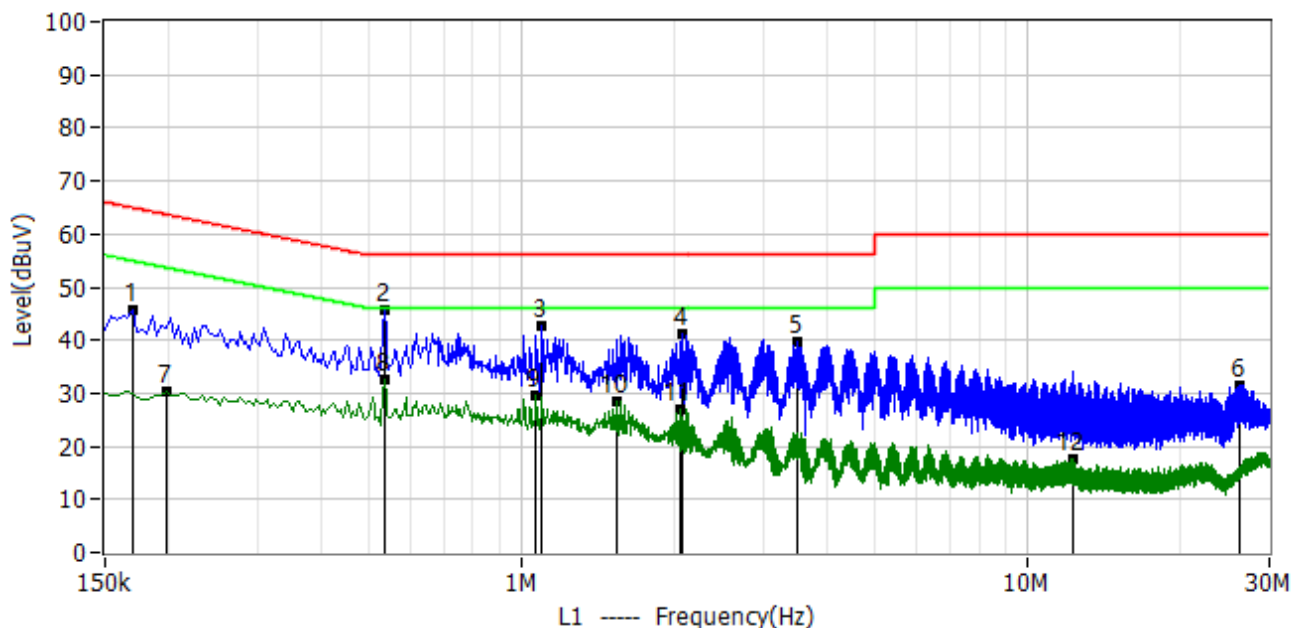

No.	Frequency MHz	Reading dBuV	Factor dB	Level dBuV	Limit dBuV	Margin dB	Detector	Polar
1*	0.170	35.22	10.63	45.85	64.96	-19.11	QP	L1
2*	0.534	34.81	10.94	45.75	56.00	-10.25	QP	L1
3*	1.094	31.70	10.91	42.61	56.00	-13.39	QP	L1
4*	2.074	29.95	11.10	41.05	56.00	-14.95	QP	L1
5*	3.514	28.54	11.28	39.82	56.00	-16.18	QP	L1
6*	26.310	19.66	11.84	31.50	60.00	-28.50	QP	L1
7*	0.198	19.58	10.72	30.30	53.69	-23.39	AV	L1
8*	0.534	21.81	10.94	32.75	46.00	-13.25	AV	L1
9*	1.066	18.52	10.89	29.41	46.00	-16.59	AV	L1
10*	1.546	17.42	11.14	28.56	46.00	-17.44	AV	L1
11*	2.050	15.75	11.10	26.85	46.00	-19.15	AV	L1
12*	12.238	6.14	11.60	17.74	50.00	-32.26	AV	L1



Project: LGT25E162	Test Engineer: LiuH
EUT: Wearable Breast Pump	Temperature: 24.9°C
M/N: W2	Humidity: 52%RH
Test Voltage: AC 120V/60Hz	Test Data: 2025-05-30
Test Mode: TX BLE 2402	
Note:	

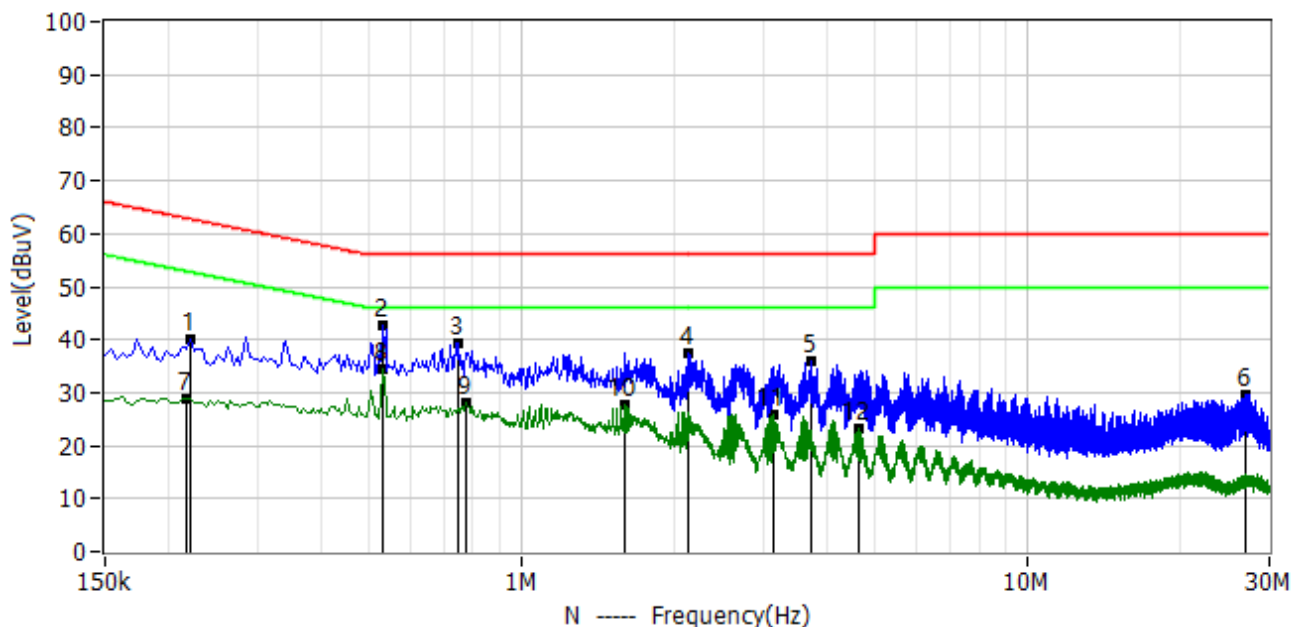

No.	Frequency MHz	Reading dBuV	Factor dB	Level dBuV	Limit dBuV	Margin dB	Detector	Polar
1*	0.222	29.56	10.69	40.25	62.74	-22.49	QP	N
2*	0.530	31.85	10.85	42.70	56.00	-13.30	QP	N
3*	0.750	28.61	10.84	39.45	56.00	-16.55	QP	N
4*	2.122	26.48	11.15	37.63	56.00	-18.37	QP	N
5*	3.714	24.54	11.26	35.80	56.00	-20.20	QP	N
6*	26.858	17.90	11.80	29.70	60.00	-30.30	QP	N
7*	0.218	18.17	10.69	28.86	52.89	-24.03	AV	N
8*	0.530	23.53	10.85	34.38	46.00	-11.62	AV	N
9*	0.774	17.34	10.83	28.17	46.00	-17.83	AV	N
10*	1.594	16.67	11.11	27.78	46.00	-18.22	AV	N
11*	3.130	14.50	11.24	25.74	46.00	-20.26	AV	N
12*	4.642	12.00	11.30	23.30	46.00	-22.70	AV	N

Remark

Level = Reading + Factor

Margin = Level - Limit



## 4. RADIATED EMISSION MEASUREMENT

### 4.1 RADIATED EMISSION LIMITS

In case the emission fall within the Restricted band specified on Part15.205 (a)&209(a), RSS-Gen and RSS-247 (5.5) limit in the table and according to ANSI C63.10-2013 below has to be followed.

#### LIMITS OF RADIATED EMISSION MEASUREMENT (0.009MHz - 1000MHz)

Frequencies (MHz)	Field Strength (micovolts/meter)	Measurement Distance (meters)
0.009~0.490	2400/F(KHz)	300
0.490~1.705	24000/F(KHz)	30
1.705~30.0	30	30
30~88	100	3
88~216	150	3
216~960	200	3
Above 960	500	3

#### LIMITS OF RADIATED EMISSION MEASUREMENT (1GHz-25 GHz)

FREQUENCY (MHz)	(dBuV/m) (at 3M)	
	PEAK	AVERAGE
Above 1000	74	54

Notes:

- (1) The limit for radiated test was performed according to FCC PART 15C.
- (2) The tighter limit applies at the band edges.
- (3) Emission level (dBuV/m)=20log Emission level (uV/m).

#### LIMITS OF RESTRICTED FREQUENCY BANDS

FREQUENCY (MHz)	FREQUENCY (MHz)	FREQUENCY (MHz)	FREQUENCY (GHz)
0.090-0.110	16.42-16.423	399.9-410	4.5-5.15
0.495-0.505	16.69475-16.69525	608-614	5.35-5.46
2.1735-2.1905	16.80425-16.80475	960-1240	7.25-7.75
4.125-4.128	25.5-25.67	1300-1427	8.025-8.5
4.17725-4.17775	37.5-38.25	1435-1626.5	9.0-9.2
4.20725-4.20775	73-74.6	1645.5-1646.5	9.3-9.5
6.215-6.218	74.8-75.2	1660-1710	10.6-12.7
6.26775-6.26825	108-121.94	1718.8-1722.2	13.25-13.4
6.31175-6.31225	123-138	2200-2300	14.47-14.5
8.291-8.294	149.9-150.05	2310-2390	15.35-16.2
8.362-8.366	156.52475-156.52525	2483.5-2500	17.7-21.4
8.37625-8.38675	156.7-156.9	2690-2900	22.01-23.12
8.41425-8.41475	162.0125-167.17	3260-3267	23.6-24.0
12.29-12.293	167.72-173.2	3332-3339	31.2-31.8
12.51975-12.52025	240-285	3345.8-3358	36.43-36.5
12.57675-12.57725	322-335.4	3600-4400	Above 38.6
13.36-13.41			



For Radiated Emission

Spectrum Parameter	Setting
Attenuation	Auto
Detector	Peak/QP/AV
Start Frequency	9 KHz/150KHz (Peak/QP/AV)
Stop Frequency	150KHz/30MHz (Peak/QP/AV)
RB / VB (emission in restricted band)	200Hz (From 9kHz to 0.15MHz)/ 9KHz (From 0.15MHz to 30MHz); 200Hz (From 9kHz to 0.15MHz)/ 9KHz (From 0.15MHz to 30MHz)

Spectrum Parameter	Setting
Attenuation	Auto
Detector	Peak/QP
Start Frequency	30 MHz (Peak/QP)
Stop Frequency	1000 MHz (Peak/QP)
RB / VB (emission in restricted band)	120 KHz / 300 KHz

Spectrum Parameter	Setting
Attenuation	Auto
Detector	Peak
Start Frequency	1000 MHz (Peak/AV)
Stop Frequency	10th carrier hamonic (Peak/AV)
RB / VB (emission in restricted band)	1 MHz / 3 MHz(Peak) 1 MHz/1/T MHz(AVG)

For Restricted band

Spectrum Parameter	Setting
Detector	Peak
Start/Stop Frequency	Lower Band Edge: 2310 to 2410 MHz Upper Band Edge: 2475 to 2500 MHz
RB / VB	1 MHz / 3 MHz(Peak) 1 MHz/1/T MHz(AVG)

Receiver Parameter	Setting
Start ~ Stop Frequency	9kHz~90kHz / RB 200Hz for PK & AV
Start ~ Stop Frequency	90kHz~110kHz / RB 200Hz for QP
Start ~ Stop Frequency	110kHz~490kHz / RB 200Hz for PK & AV
Start ~ Stop Frequency	490kHz~30MHz / RB 9kHz for QP
Start ~ Stop Frequency	30MHz~1000MHz / RB 120kHz for QP



#### 4.2 TEST PROCEDURE

- a. The measuring distance at 3 m shall be used for measurements at frequency 0.009MHz up to 1GHz, and above 1GHz.
- b. The EUT was placed on the top of a rotating table 0.8 m (above 1GHz is 1.5 m) above the ground at a 3 m anechoic chamber test site. The table was rotated 360 degree to determine the position of the highest radiation.
- c. The height of the equipment shall be 0.8 m(above 1GHz is 1.5 m); the height of the test antenna shall vary between 1 m to 4 m. Horizontal and vertical polarization of the antenna are set to make the measurement.
- d. The initial step in collecting conducted emission data is a spectrum analyzer peak detector mode pre-scanning the measurement frequency range. Significant peaks are then marked and QuasiPeak detector mode will be re-measured.
- e. If the Peak Mode measured value is compliance with and lower than Quasi Peak Mode Limit, the EUT shall be deemed to meet QP Limits and no additional QP Mode measurement was performed.
- f. For the actual test configuration, please refer to the related Item –EUT Test Photos.

Note:

Both horizontal and vertical antenna polarities were tested and performed pretest to three orthogonal axis. The worst case emissions were reported.

### 4.3 TEST SETUP

#### (A) Radiated Emission Test-Up Frequency Below 30MHz

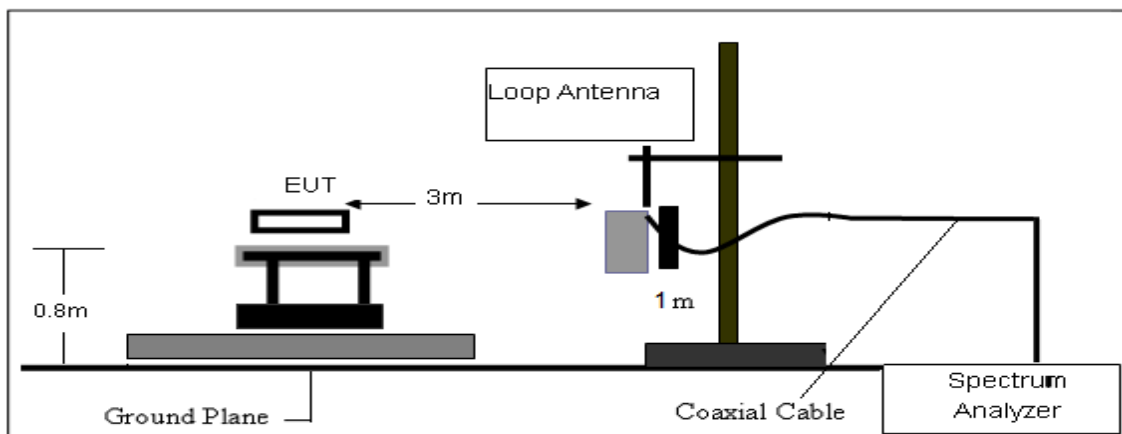

#### (B) Radiated Emission Test-Up Frequency 30MHz~1GHz

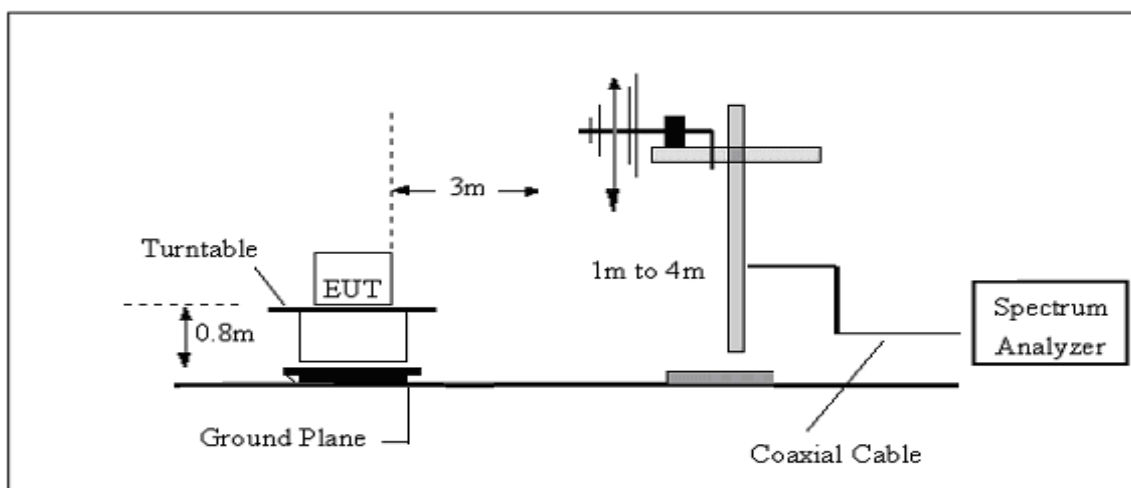

#### (C) Radiated Emission Test-Up Frequency Above 1GHz

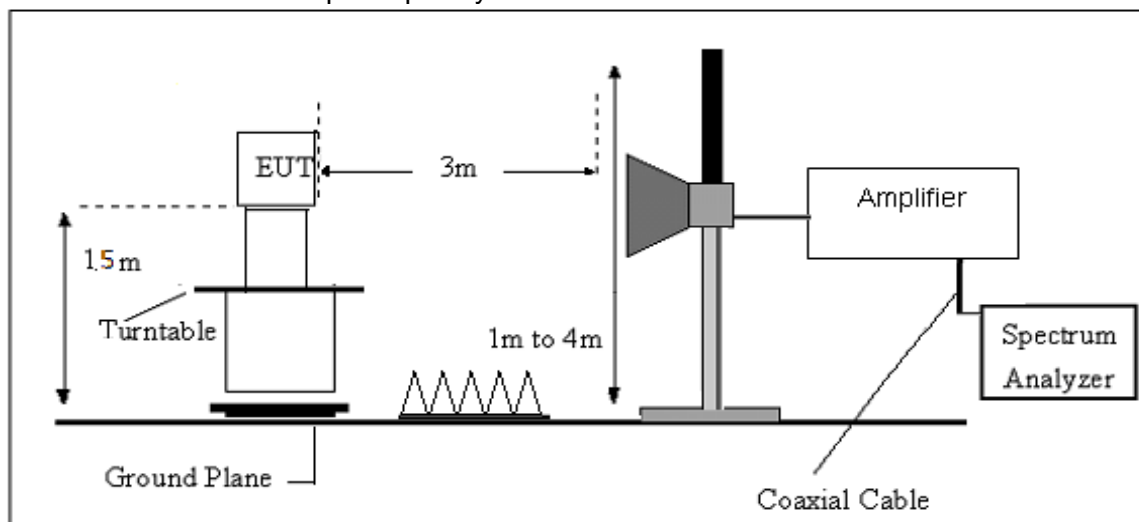

### 4.4 EUT OPERATING CONDITIONS

Please refer to section 3.4 of this report.



#### 4.5 FIELD STRENGTH CALCULATION

The field strength is calculated by adding the Antenna Factor and Cable Factor and subtracting the Amplifier Gain and Duty Cycle Correction Factor (if any) from the measured reading. The basic equation with a sample calculation is as follows:

$$FS = RA + AF + CL - AG$$

Where

FS = Field Strength

CL = Cable Attenuation Factor (Cable Loss)

RA = Reading Amplitude

AG = Amplifier Gain

AF = Antenna Factor

For example

Frequency (MHz)	FS (dB $\mu$ V/m)	RA (dB $\mu$ V/m)	AF (dB)	CL (dB)	AG (dB)	Factor (dB)
300	40	58.1	12.2	1.6	31.9	-18.1

$$\text{Factor} = \text{AF} + \text{CL} - \text{AG}$$



## 4.6 TEST RESULTS

### Results of Radiated Emissions (9 KHz~30MHz)

No.	Frequency	Reading dBuV	Factor dB/m	Level dBuV/m	Limit dBuV/m	Margin dB	Detector	Remark
1*	-	-	-	-	-	-	-	See Note

Note:

The emission from 9 kHz to 30MHz was pre-tested and found the result was 20dB lower than the limit, and the permissible value has no need to be reported.

Distance extrapolation factor =  $40 \log (\text{specific distance} / \text{test distance})$  (dB);

Limit line = specific limits (dBuV) + distance extrapolation factor.





Results of Radiated Emissions (30MHz~1000MHz)

Note:1. All mode has been tested, only shown the worst case data,  
 2. The peak value is less than the AV limit, so no AV data is displayed.

Project: LGT25E162	Test Engineer: LiuH
EUT: Wearable Breast Pump	Temperature: 24℃
M/N: W2	Humidity: 50%RH
Test Voltage: Battery	Test Data: 2025-06-03
Test Mode: TX BLE 2402	
Note:	

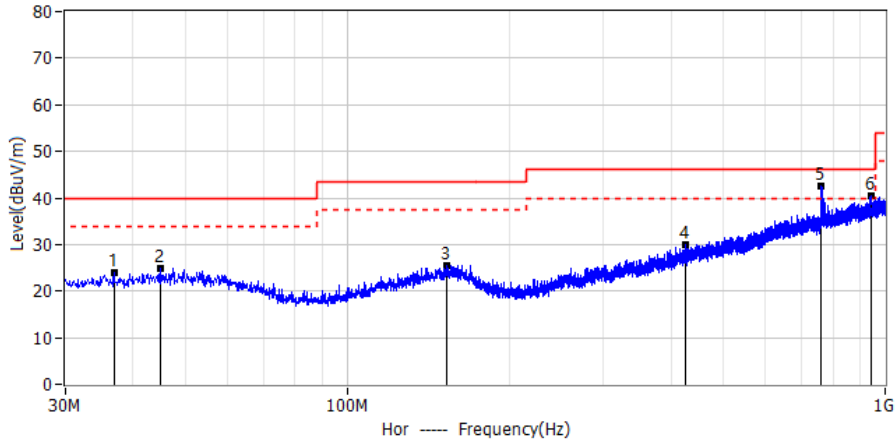

No.	Frequency MHz	Reading dBuV	Factor dB/m	Level dBuV/m	Limit dBuV/m	Margin dB	Detector	Polar
1*	36.911	3.83	20.10	23.93	40.00	-16.07	QP	Hor
2*	45.156	4.31	20.70	25.01	40.00	-14.99	QP	Hor
3*	153.069	3.42	22.11	25.53	43.50	-17.97	QP	Hor
4*	426.003	4.08	25.93	30.01	46.00	-15.99	QP	Hor
5*	761.744	10.42	32.23	42.65	46.00	-3.35	QP	Hor
6*	941.800	5.67	34.69	40.36	46.00	-5.64	QP	Hor

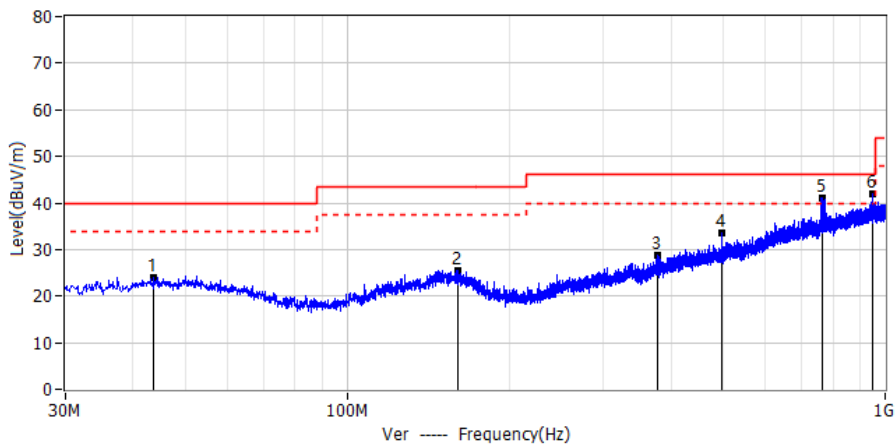

No.	Frequency MHz	Reading dBuV	Factor dB/m	Level dBuV/m	Limit dBuV/m	Margin dB	Detector	Polar
1*	43.823	3.05	21.00	24.05	40.00	-15.95	QP	Ver
2*	160.950	3.81	21.78	25.59	43.50	-17.91	QP	Ver
3*	376.775	4.42	24.43	28.85	46.00	-17.15	QP	Ver
4*	496.934	6.07	27.39	33.46	46.00	-12.54	QP	Ver
5*	762.714	8.88	32.19	41.07	46.00	-4.93	QP	Ver
6*	948.469	7.11	34.91	42.02	46.00	-3.98	QP	Ver

Remark

Level = Reading + Factor

Margin = Level – Limit



Results of Radiated Emissions (Above 1000MHz)

Frequency (MHz)	Reading (dBμV)	Corrected Factor (dB)	Result (dBμV/m)	Limits (dBμV/m)	Margin (dB)	Detector	Polarity
Low Channel (2402 MHz)							
3264.70	55.81	-8.45	47.36	74.00	-26.64	PK	Vertical
3264.70	45.00	-8.45	36.55	54.00	-17.45	AV	Vertical
3264.78	56.22	-8.45	47.77	74.00	-26.23	PK	Horizontal
3264.78	45.05	-8.45	36.60	54.00	-17.40	AV	Horizontal
4804.32	55.20	-6.09	49.11	74.00	-24.89	PK	Vertical
4804.32	45.13	-6.09	39.04	54.00	-14.96	AV	Vertical
4804.61	55.15	-6.09	49.06	74.00	-24.94	PK	Horizontal
4804.61	45.12	-6.09	39.03	54.00	-14.97	AV	Horizontal
5359.78	57.77	-6.68	51.09	74.00	-22.91	PK	Vertical
5359.78	48.14	-6.68	41.46	54.00	-12.54	AV	Vertical
5359.83	56.97	-6.68	50.29	74.00	-23.71	PK	Horizontal
5359.83	48.24	-6.68	41.56	54.00	-12.44	AV	Horizontal
7205.91	60.26	-8.13	52.13	74.00	-21.87	PK	Vertical
7205.91	49.99	-8.13	41.86	54.00	-12.14	AV	Vertical
7205.70	60.84	-8.13	52.71	74.00	-21.29	PK	Horizontal
7205.70	49.94	-8.13	41.81	54.00	-12.19	AV	Horizontal
Middle Channel (2440 MHz)							
3264.68	56.41	-8.45	47.96	74.00	-26.04	PK	Vertical
3264.68	45.97	-8.45	37.52	54.00	-16.48	AV	Vertical
3264.63	55.76	-8.45	47.31	74.00	-26.69	PK	Horizontal
3264.63	46.76	-8.45	38.31	54.00	-15.69	AV	Horizontal
4880.58	55.41	-6.09	49.32	74.00	-24.68	PK	Vertical
4880.58	44.21	-6.09	38.12	54.00	-15.88	AV	Vertical
4880.33	54.91	-6.09	48.82	74.00	-25.18	PK	Horizontal
4880.33	45.28	-6.09	39.19	54.00	-14.81	AV	Horizontal
5359.68	57.47	-6.68	50.79	74.00	-23.21	PK	Vertical
5359.68	47.27	-6.68	40.59	54.00	-13.41	AV	Vertical
5359.79	57.26	-6.68	50.58	74.00	-23.42	PK	Horizontal
5359.79	46.99	-6.68	40.31	54.00	-13.69	AV	Horizontal
7310.71	60.43	-8.13	52.30	74.00	-21.70	PK	Vertical
7310.71	50.26	-8.13	42.13	54.00	-11.87	AV	Vertical
7310.94	60.92	-8.13	52.79	74.00	-21.21	PK	Horizontal
7310.94	50.87	-8.13	42.74	54.00	-11.26	AV	Horizontal
High Channel (2480 MHz)							
3264.74	56.09	-8.45	47.64	74.00	-26.36	PK	Vertical



3264.74	46.71	-8.45	38.26	54.00	-15.74	AV	Vertical
3264.78	55.41	-8.45	46.96	74.00	-27.04	PK	Horizontal
3264.78	46.57	-8.45	38.12	54.00	-15.88	AV	Horizontal
4960.42	54.42	-6.09	48.33	74.00	-25.67	PK	Vertical
4960.42	44.79	-6.09	38.70	54.00	-15.30	AV	Vertical
4960.56	54.57	-6.09	48.48	74.00	-25.52	PK	Horizontal
4960.56	44.18	-6.09	38.09	54.00	-15.91	AV	Horizontal
5359.78	57.95	-6.68	51.27	74.00	-22.73	PK	Vertical
5359.78	48.26	-6.68	41.58	54.00	-12.42	AV	Vertical
5359.79	56.78	-6.68	50.10	74.00	-23.90	PK	Horizontal
5359.79	47.00	-6.68	40.32	54.00	-13.68	AV	Horizontal
7439.70	60.22	-8.13	52.09	74.00	-21.91	PK	Vertical
7439.70	49.92	-8.13	41.79	54.00	-12.21	AV	Vertical
7439.89	60.58	-8.13	52.45	74.00	-21.55	PK	Horizontal
7439.89	50.95	-8.13	42.82	54.00	-11.18	AV	Horizontal

Remark:

Result = Reading +Correct

Margin = Result – Limit

In frequency ranges above 18GHz no any other harmonic emissions detected which are tested to compliance with the limit. No recording in the test report. No any other emissions level which are attenuated less than 20dB below the limit. No recording in the test report.



#### 4.7 TEST RESULTS (BAND EDGE REQUIREMENTS)

Note: All mode has been tested, only shown the worst case data,

Frequency (MHz)	Reading (dB $\mu$ V)	Corrected Factor (dB)	Result (dB $\mu$ V/m)	Limits (dB $\mu$ V/m)	Margin (dB)	Detector	Polarity
GFSK							
2390.00	13.59	34.10	47.69	74.00	-26.31	PK	Vertical
2390.00	2.02	34.10	36.12	54.00	-17.88	AV	Vertical
2400.00	13.59	34.11	47.70	74.00	-26.30	PK	Vertical
2400.00	0.69	34.11	34.80	54.00	-19.20	AV	Vertical
2390.00	13.59	34.10	47.69	74.00	-26.31	PK	Horizontal
2390.00	1.12	34.10	35.22	54.00	-18.78	AV	Horizontal
2400.00	12.69	34.11	46.80	74.00	-27.20	PK	Horizontal
2400.00	2.01	34.11	36.12	54.00	-17.88	AV	Horizontal
2483.50	12.60	34.44	47.04	74.00	-26.96	PK	Vertical
2483.50	1.59	34.44	36.03	54.00	-17.97	AV	Vertical
2500.00	13.50	34.46	47.96	74.00	-26.04	PK	Vertical
2500.00	0.71	34.46	35.17	54.00	-18.83	AV	Vertical
2483.50	12.54	34.44	46.98	74.00	-27.02	PK	Horizontal
2483.50	2.01	34.44	36.45	54.00	-17.55	AV	Horizontal
2500.00	12.32	34.46	46.78	74.00	-27.22	PK	Horizontal
2500.00	2.09	34.46	36.55	54.00	-17.45	AV	Horizontal
Low measurement frequencies is range from 2310 to 2404 MHz, high measurement frequencies is range from 2478 to 2500 MHz.							



## 5. CONDUCTED SPURIOUS & BAND EDGE EMISSION

### 5.1 LIMIT

According to FCC section 15.247(d)&RSS-247, in any 100kHz bandwidth outside the frequency band in which the spread spectrum or digitally modulated intentional radiator is operating, the radio frequency power that is produced by the intentional radiator shall be at least 20dB below that in the 100kHz bandwidth within the band that contains the highest level of the desired power, based on either an RF conducted or a radiated measurement.

### 5.2 TEST PROCEDURE

Spectrum Parameter	Setting
Detector	Peak
Start/Stop Frequency	30 MHz to 10th carrier harmonic
RB / VB (emission in restricted band)	100 KHz/300 KHz
Trace-Mode:	Max hold

For Band edge

Spectrum Parameter	Setting
Detector	Peak
Start/Stop Frequency	Lower Band Edge: 2300 – 2407 MHz Upper Band Edge: 2475 – 2500 MHz
RB / VB (emission in restricted band)	100 KHz/300 KHz
Trace-Mode:	Max hold

### 5.3 TEST SETUP



The EUT which is powered by the battery, is connected to the Spectrum Analyzer; the RF load attached to the EUT antenna terminal is 50 Ohm; the path loss as the factor is calibrated to correct the reading. Make the measurement with the spectrum analyzer's resolution bandwidth(RBW) = 100 kHz. In order to make an accurate measurement, set the span greater than RBW.

### 5.4 EUT OPERATION CONDITIONS

Please refer to section 3.4 of this report.

### 5.5 TEST RESULTS

For the measurement records, refer to the appendix I.



## 6. POWER SPECTRAL DENSITY TEST

### 6.1 LIMIT

Section	Test Item	Limit	Frequency Range (MHz)	Result
15.247(e) RSS-247	Power Spectral Density	$\leq 8$ dBm (RBW $\geq 3$ KHz)	2400-2483.5	PASS

### 6.2 TEST PROCEDURE

1. Set analyzer center frequency to DTS channel center frequency.
2. Set the span to 1.5 times the DTS channel bandwidth.
3. Set the RBW to:  $100 \text{ kHz} \geq \text{RBW} \geq 3 \text{ kHz}$ .
4. Set the VBW  $\geq 3 \times \text{RBW}$ .
5. Detector = peak.
6. Sweep time = auto couple.
7. Trace mode = max hold.
8. Allow trace to fully stabilize.
9. Use the peak marker function to determine the maximum amplitude level.
10. If measured value exceeds limit, reduce RBW (no less than 3 kHz) and repeat.

### 6.3 TEST SETUP



### 6.4 EUT OPERATION CONDITIONS

Please refer to section 3.4 of this report.

### 6.5 TEST RESULTS

For the measurement records, refer to the appendix I.



## 7. BANDWIDTH TEST

### 7.1 LIMIT

Section	Test Item	Limit	Frequency Range (MHz)	Result
15.247(a)(2) RSS-247 5.2 (a)	Bandwidth	$\geq 500\text{KHz}$ (6dB bandwidth)	2400-2483.5	PASS
RSS-Gen Clause 6.7	99% Bandwidth	For reporting purposes only.	2400-2483.5	PASS

### 7.2 TEST PROCEDURE

Connect the UUT to the spectrum analyser and use the following settings:

Center Frequency	The centre frequency of the channel under test
Detector	Peak
RBW	For 6 dB Bandwidth :100KHz For 99% Bandwidth :1% to 5% of the occupied bandwidth
VBW	For 6dB Bandwidth : $\geq 3 \times \text{RBW}$ For 99% Bandwidth : approximately $3 \times \text{RBW}$
Trace	Max hold
Sweep	Auto

Allow the trace to stabilize and measure the maximum width of the emission that is constrained by the frequencies associated with the two outermost amplitude points (upper and lower frequencies) that are attenuated by 6 dB and 99% relative to the maximum level measured in the fundamental emission.

### 7.3 TEST SETUP



### 7.4 EUT OPERATION CONDITIONS

Please refer to section 3.4 of this report.

### 7.5 TEST RESULTS

For the measurement records, refer to the appendix I.



## 8. PEAK OUTPUT POWER TEST

### 8.1 LIMIT

Section	Test Item	Limit	Frequency Range (MHz)	Result
15.247(b)(3) RSS-247	Output Power	1 watt or 30dBm	2400-2483.5	PASS
RSS-247	EIRP	4W	2400-2483.5	PASS

### 8.2 TEST PROCEDURE

ANSI C63.10 2013 section 11.9.1.3

PKPM1 Peak power sensor method:

The maximum peak conducted output power may be measured using a broadband peak RF power sensor. The power sensor shall have a video bandwidth that is greater than or equal to the DTS bandwidth and shall use a fast-responding diode detector.

### 8.3 TEST SETUP



### 8.4 EUT OPERATION CONDITIONS

Please refer to section 3.4 of this report.

### 8.5 TEST RESULTS

For the measurement records, refer to the appendix I.





## 9. ANTENNA REQUIREMENT

### 9.1 STANDARD REQUIREMENT

15.203 requirement: For intentional device, according to 15.203: an intentional radiator shall be designed to ensure that no antenna other than that furnished by the responsible party shall be used with the device.

RSS Gen Section 6.8 requirement: The applicant for equipment certification shall provide a list of all antenna types that may be used with the transmitter, where applicable (i.e. for transmitters with detachable antenna), indicating the maximum permissible antenna gain (in dBi) and the required impedance for each antenna. The test report shall demonstrate the compliance of the transmitter with the limit for maximum equivalent isotropically radiated power (e.i.r.p.) specified in the applicable RSS, when the transmitter is equipped with any antenna type, selected from this list.

For expediting the testing, measurements may be performed using only the antenna with highest gain of each combination of transmitter and antenna type, with the transmitter output power set at the maximum level. However, the transmitter shall comply with the applicable requirements under all operational conditions and when in combination with any type of antenna from the list provided in the test report (and in the notice to be included in the user manual, provided below).

When measurements at the antenna port are used to determine the RF output power, the effective gain of the device's antenna shall be stated, based on a measurement or on data from the antenna's manufacturer.

The test report shall state the RF power, output power setting and spurious emission measurements with each antenna type that is used with the transmitter being tested.

For licence-exempt equipment with detachable antennas, the user manual shall also contain the following notice in a conspicuous location:

This radio transmitter [enter the device's ISED certification number] has been approved by Innovation, Science and Economic Development Canada to operate with the antenna types listed below, with the maximum permissible gain indicated. Antenna types not included in this list that have a gain greater than the maximum gain indicated for any type listed are strictly prohibited for use with this device.

Immediately following the above notice, the manufacturer shall provide a list of all antenna types which can be used with the transmitter, indicating the maximum permissible antenna gain (in dBi) and the required impedance for each antenna type.

### 9.2 EUT ANTENNA

The EUT antenna is PCB Antenna. It comply with the standard requirement.



## 10. FREQUENCY STABILITY

### 10.1 LIMITS OF FREQUENCY STABILITY MEASUREMENT

The frequency tolerance of the carrier signal shall be maintained within +/-0.02% of the operating frequency over a temperature variation of -30 degrees to 50 degrees C at normal supply voltage and for a variation in primary supply voltage from 85% to 115% of the rated supply voltage at a temperature of 20 degrees.

### 10.2 TEST PROCEDURE

1. The EUT was placed inside the environmental test chamber and powered by nominal DC voltage.
2. Turn the EUT on and couple its output to spectrum analyzer.
3. Turn the EUT off and set the chamber to the highest temperature specified.
4. Allow sufficient time (approximately 30 min) for the temperature of the chamber to stabilize, turn the EUT on and measure the operating frequency after 2,5 and 10 minutes.
5. Repeat step 2 and 3 with the temperature chamber set to the lowest temperature.
6. The test chamber was allowed to stabilize at +20 degree C for a minimum of 30 minutes. The supply voltage was then adjusted on the EUT from 85% to 115% and the frequency record.

### 10.3 TEST RESULT

For the measurement records, refer to the appendix I.



## APPENDIX I - TEST RESULTS

### Annex A. Output Power

EUT Frequency(MHz)	Mode	Detector	Level(dBm)	Limit(dBm)	Verdict
2402	BLE 1Mbps	Peak	-6.17	30	Pass
2440	BLE 1Mbps	Peak	-4.01	30	Pass
2480	BLE 1Mbps	Peak	-4.98	30	Pass

Frequency (MHz)	Mode	Frequency (MHz)	Conducted Power (dBm)	ANT GAIN (dBi)	EIRP(dBm)	EIRP LIMIT(dBm)	Verdict
2402	BLE 1Mbps	2402	-6.17	2.5	-3.67	36.02	Pass
2440	BLE 1Mbps	2440	-4.01	2.5	-1.51	36.02	Pass
2480	BLE 1Mbps	2480	-4.98	2.5	-2.48	36.02	Pass



Annex A. 6dB Bandwidth

Mode	Center Frequency (MHz)	XdB Down	RBW (MHz)	Detector	Limit (MHz)	XdB BandWidth (MHz)	Verdict
BLE 1Mbps	2402	6	0.1	Peak	0.5	0.682	Pass
BLE 1Mbps	2440	6	0.1	Peak	0.5	0.682	Pass
BLE 1Mbps	2480	6	0.1	Peak	0.5	0.682	Pass

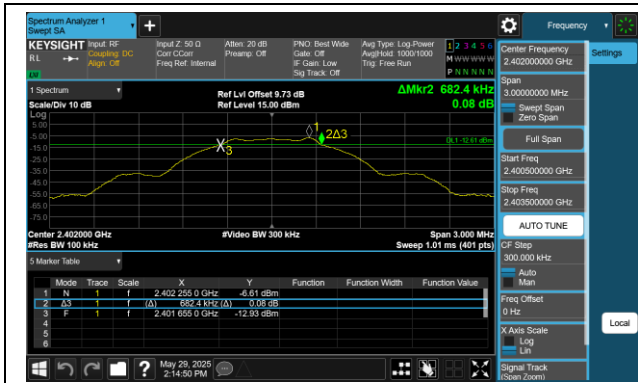

BLE 1Mbps 2402MHz



BLE 1Mbps 2440MHz



BLE 1Mbps 2480MHz



Annex A. 99% Bandwidth

Mode	Center Frequency (MHz)	OBW Power (%)	RBW (MHz)	Detector	OBW (MHz)	Verdict
BLE 1Mbps	2402	99	0.03	Peak	1.04	Pass
BLE 1Mbps	2440	99	0.03	Peak	1.045	Pass
BLE 1Mbps	2480	99	0.03	Peak	1.046	Pass



BLE 1Mbps 2402MHz

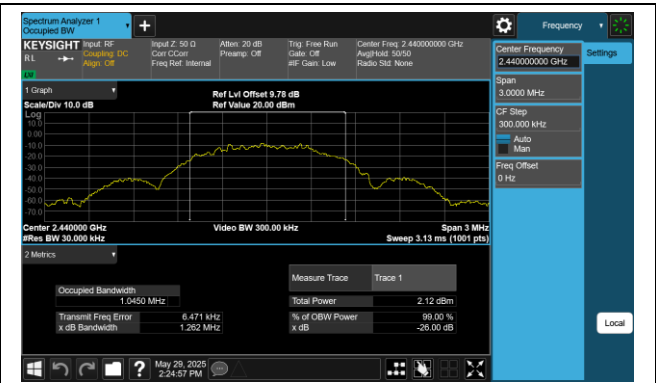

BLE 1Mbps 2440MHz

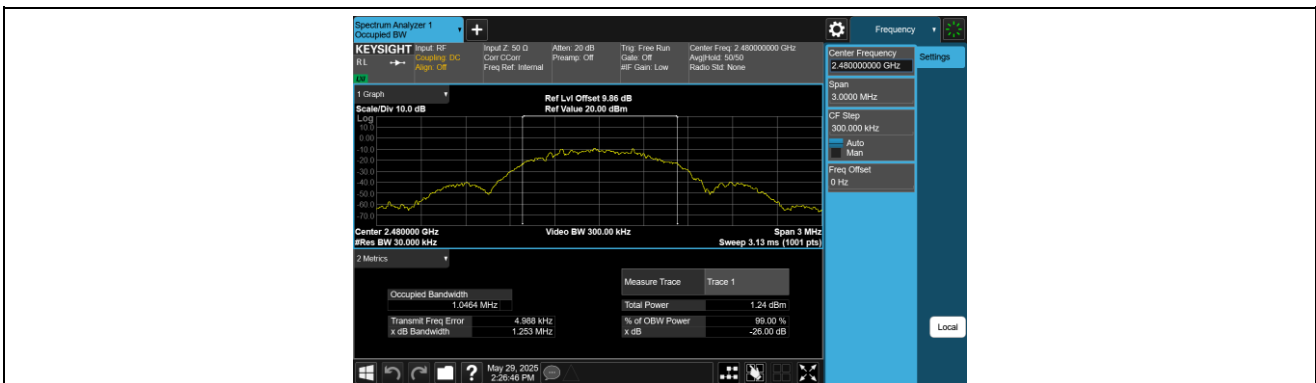

BLE 1Mbps 2480MHz



Annex A. Conducted Spurious Emissions  
 1. Bluetooth Low Energy  
 1.1 A.3-Conducted Spurious Emissions

Frequency(MHz)	Level(dBm)
1939.71	-30.511
23959.25	-40.097

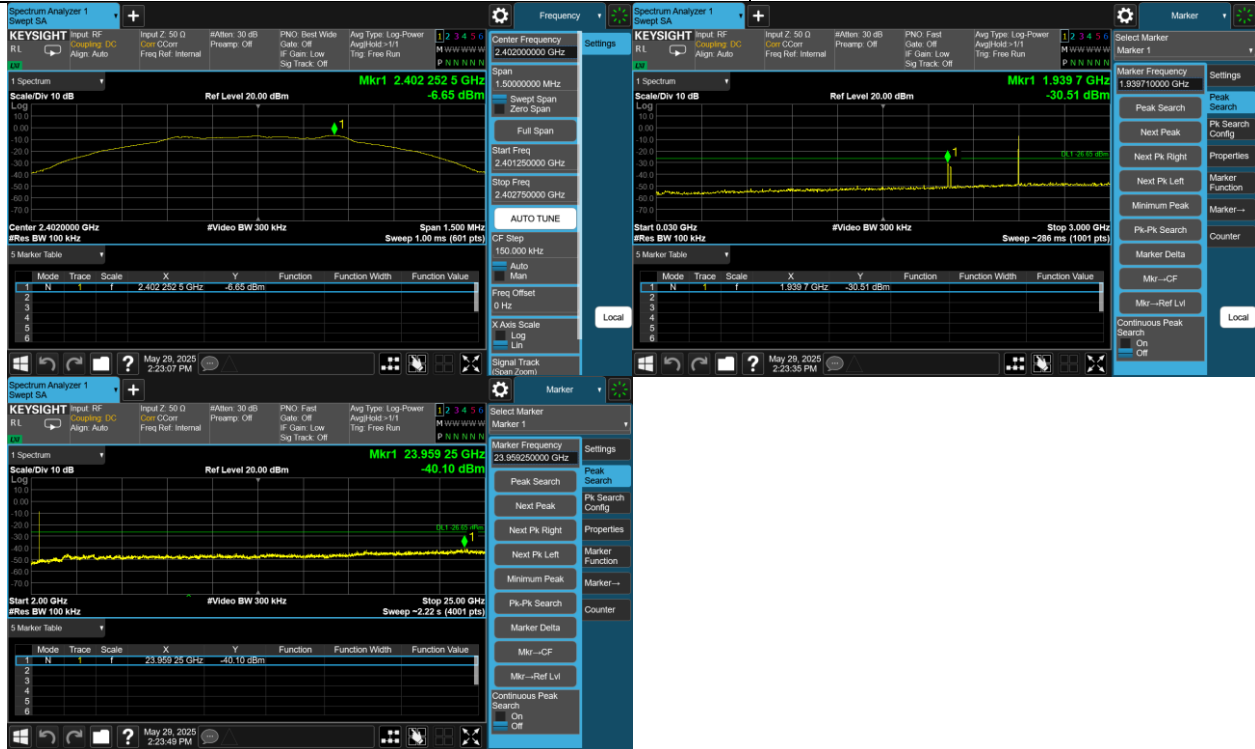

Note: The over-limit position is the main frequency. No mark is needed.



### 1.2 A.3-Conducted Spurious Emissions

Frequency(MHz)	Level(dBm)
1939.71	-27.695
23729.25	-40.696



Note: The over-limit position is the main frequency. No mark is needed.



### 1.3 A.3-Conducted Spurious Emissions

Frequency(MHz)	Level(dBm)
1957.53	-29.741
24448	-41.486



Note: The over-limit position is the main frequency. No mark is needed.





## Annex A. Bandedge(H)--CSE





# Annex A. Bandedge(L)--CSE

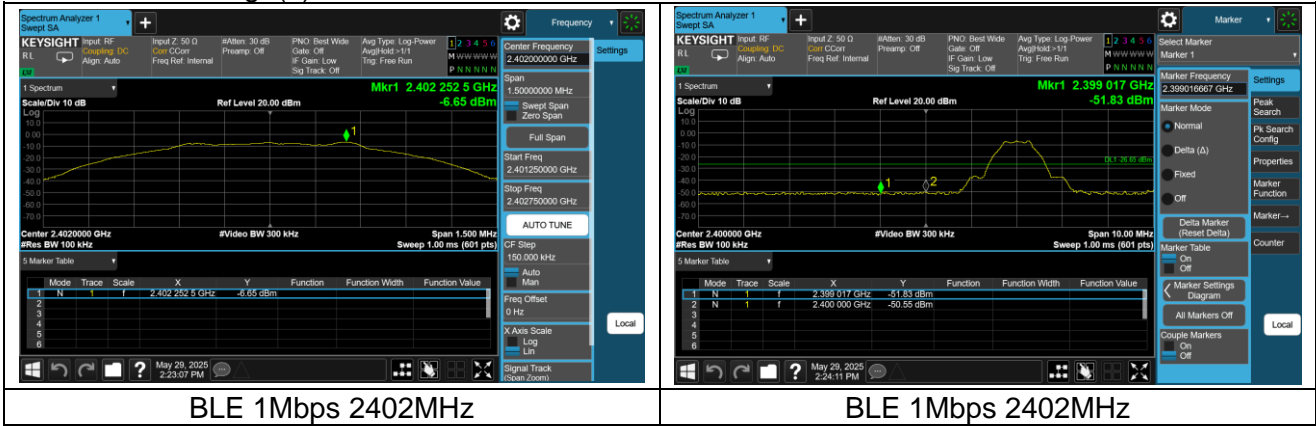

BLE 1Mbps 2402MHz

BLE 1Mbps 2402MHz



### Annex A. Power Spectral Density (PSD)

EUT Frequency (MHz)	Mode	Detector	RBW(MHz)	Level(dBm/3kHz)	Limit(dBm/3kHz)	Verdict
2402	BLE 1Mbps	Peak	0.003	-22.75	8	Pass
2440	BLE 1Mbps	Peak	0.003	-20.37	8	Pass
2480	BLE 1Mbps	Peak	0.003	-21.65	8	Pass

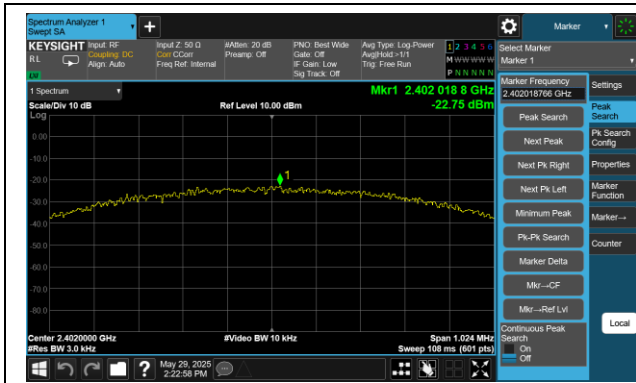

BLE 1Mbps 2402MHz

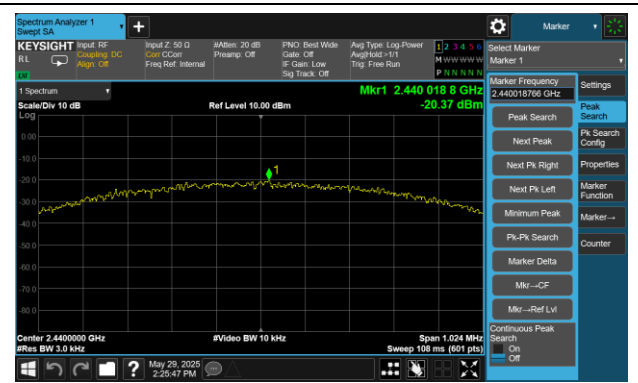

BLE 1Mbps 2440MHz

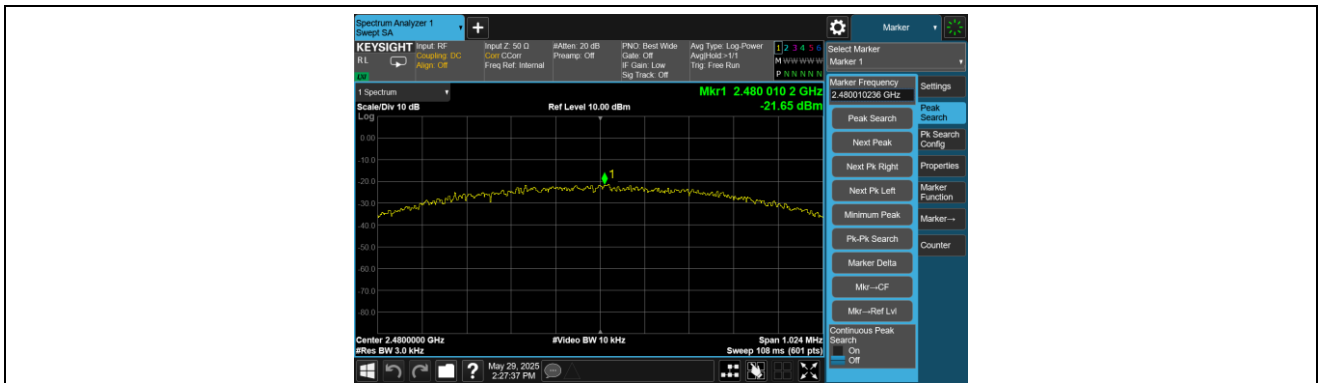

BLE 1Mbps 2480MHz



### Annex A. Duty Cycle

Mode	Center Frequency (MHz)	RBW (MHz)	Detector	Tx On (s)	Tx Off (s)	Period (s)	Duty Cycle	Verdict
BLE 1Mbps	2402	8	RMS	0.002127	0.000373	0.0025	0.8507	Pass
BLE 1Mbps	2440	8	RMS	0.002127	0.000373	0.0025	0.8507	Pass
BLE 1Mbps	2480	8	RMS	0.002127	0.000373	0.0025	0.8507	Pass



BLE 1Mbps 2402MHz



BLE 1Mbps 2440MHz

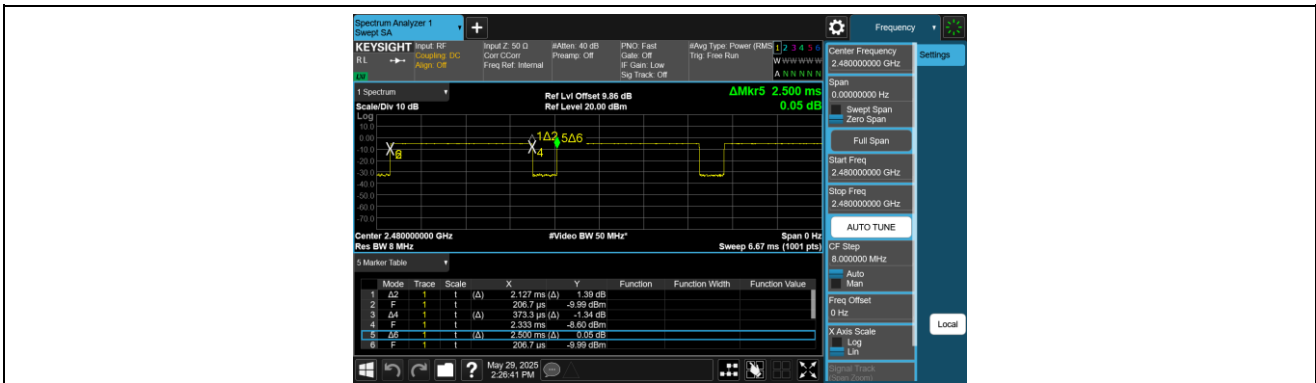

BLE 1Mbps 2480MHz



## FREQUENCY STABILITY

Channel 19	2440.0000
Voltage(V)	Measurement Frequency(MHz)
4.4275	2440.0021
3.85	2440.0015
3.2725	2440.0019
Max.Deviation(MHz)	0.0021
Max.Deviation(ppm)	0.86

Temperature(°C)	Measurement Frequency(MHz)
-30	2440.0025
-20	2440.0021
-10	2440.0018
0	2440.0024
10	2440.0017
20	2440.0022
30	2440.0022
40	2440.0023
50	2440.0022
Max.Deviation(MHz)	0.0025
Max.Deviation(ppm)	1.02



## APPENDIX II - MEASUREMENT PHOTOS

Note: Please see the attached RF\_Test Setup photos for FCC ID & IC.

※※※※※END OF THE REPORT※※※※※