

承认书

SPECIFICATION FOR APPROVAL

客户名称 : 深圳市铭景天电子有限公司
CUSTOMER'S NAME : Shenzhen Mingjingtian Electronics Co., Ltd

客户料号 : _____
CUSTOMER'S P/N : _____

产品规格 : Y. A11. 333
PRODUCT SPEC : _____

制作日期 : 2024年9月25日
ISSUE DATE : _____

拟制 PREPARED BY	审核 CHECKED BY	批准 APPROVED BY	客户承认 CUSTOMER APPROVE
李蓓	程杰	李博文	



东莞市博红科技有限公司

DONGGUAN BOHONG TECHNOLOGY CO., LTD

ADD: 4th Floor, 533 Fumin Middle Road, Dalang Town, Dongguan City

TEL: 0769-82866410

FAX: 0769-82866409

本承认书请在首批下单生产此机种前回签, 否则视为贵方默认此承认书内所有内容

东莞市博红科技有限公司

DONGGUAN BOHONG TECHNOLOGY CO., LTD

SPECIFICATION FOR APPROVAL

CUSTOMER	铭景天	CUSTOMER S. P/N	0
ISSUE DATE	2024年9月25日	PRODUCT SPEC	Y. A11. 333

2. DIMENSION:

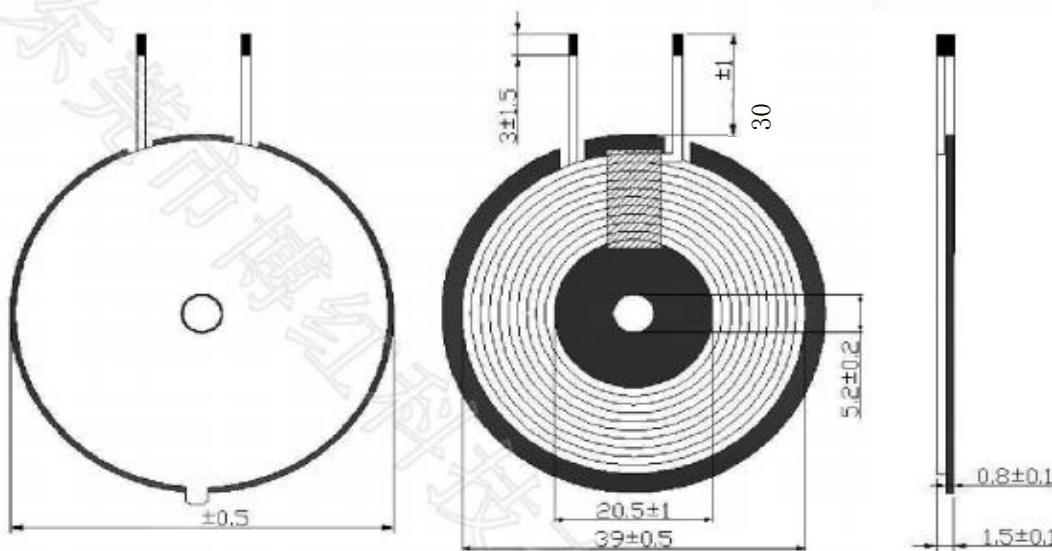

43.5

注:

- 双面胶，带手撕位；
- 线圈表面干净整洁，不散线，缝隙不超过线径的1/2；
- 线圈居中贴在磁片，起绕线入槽；

Note:

Double-sided adhesive tape, with tear-off tabs;

2. The surface of the coil is clean and tidy, without loose wires, and the gap does not exceed half of the wire diameter.

3. The coil is centered and placed on the magnetic sheet, serving as the guide for winding the wire into the slot.

ISSUE BY	李蓓	CHECK BY	程杰	APPROVAL BY	李博文
----------	----	----------	----	-------------	-----

东莞市博红科技有限公司

DONGGUAN BOHONG TECHNOLOGY CO., LTD

SPECIFICATION FOR APPROVAL



CUSTOMER	铭景天	CUSTOMER S.P/N	0
ISSUE DATE	2024年9月25日	PRODUCT SPEC	Y.A11.333

4. CIRCUIT DIAGRAM

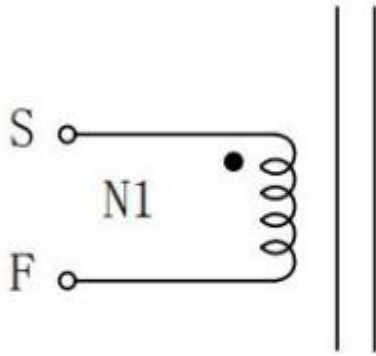

" • ": POLARITY/极性

5. WINDING

NO	WINDING	WIRE	TURNS	TAPE	WINDING CONDITION
N1	S-F	Ø0.08*24P*2P	10	/	CCW

6. CHARACTERISTIC

ITEM	MEASURED POINT	TECHNICAL DATA	TESTING CONDITION & INSTRUMENT
LS	S-F	6.3uH ±10%	LCR1062 100KHz/1V AT 25°C ± 2°C

东莞市博红科技有限公司

DONGGUAN BOHONG TECHNOLOGY CO., LTD

SPECIFICATION FOR APPROVAL

CUSTOMER	铭景天	CUSTOMER S.P/N	0
ISSUE DATE	2024年9月25日	PRODUCT SPEC	V. A11.333

备忘录

序号	内容	处理方法	签名	日期
1				
2				
3				
4				
5				
6				
7				
8				
9				
10				