

Features

- 1.Surface Mounted Devices with a small dimension of 3.6 x 1.6 x 0.5 mm³ meet future miniaturization trend.
- 2.Embedded and LTCC (Low Temperature Co-fired Ceramic) technology is able to future integrate with system design as well as beautifying the housing of final product.
3. High Stability in Temperature / Humidity Change

Applications

1. Bluetooth
2. Wireless LAN
3. ISM band 2.4GHz wireless applications

Dimensions (Unit: mm)

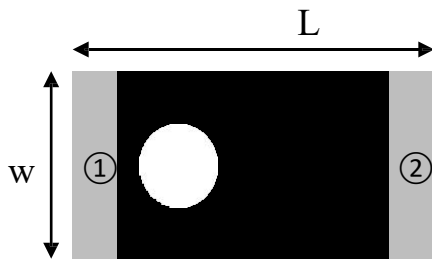

(Top View)

Number	Terminal Name
①	INPUT
②	NC

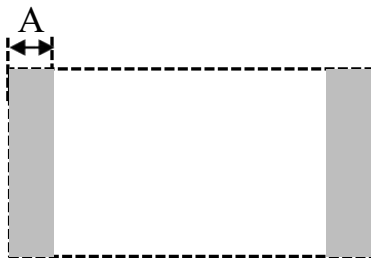

(Bottom View)



(Side View)

Symbols	L	W	T	A
Dimensions	3.2+/-0.2	1.6+/-0.2	0.5+/-0.1	0.4+/-0.1

Evaluation Board and Matching Circuits

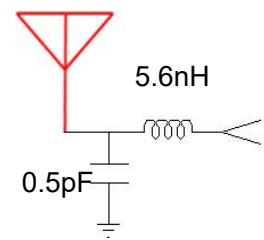
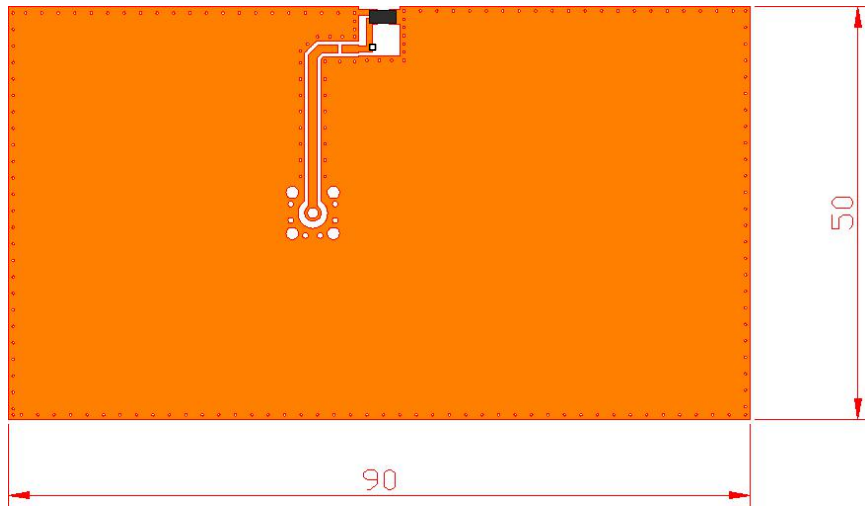
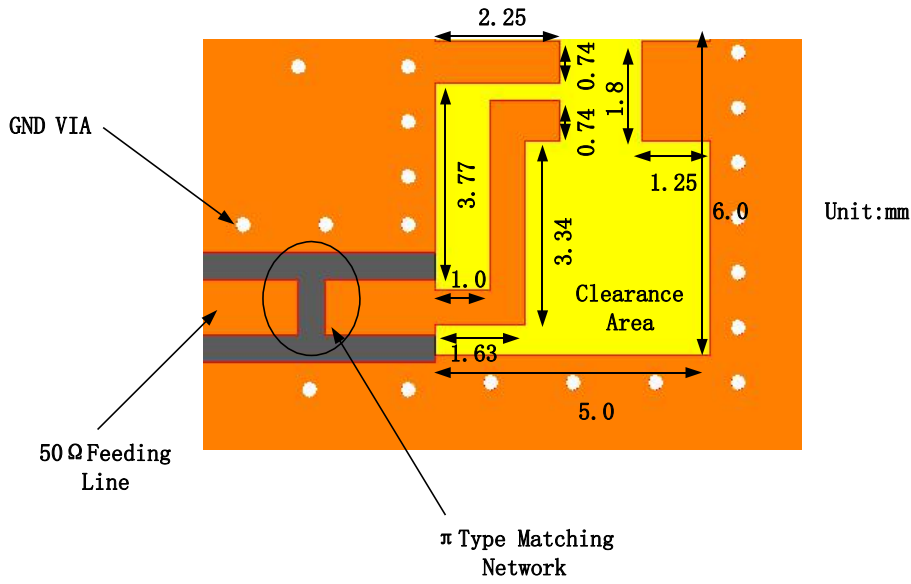

Electrical Characteristics

No.	Item	Specifications
1	Central Frequency	2545MHz
2	Band Width	100 MHz typ.
3	Peak Gain	5.54 dBi
4	Return Loss	≤2.0
5	Polarization	Linear
6	Azimuth Beam width	Omni-directional
7	Impedance	50 Ω

Characteristic curve

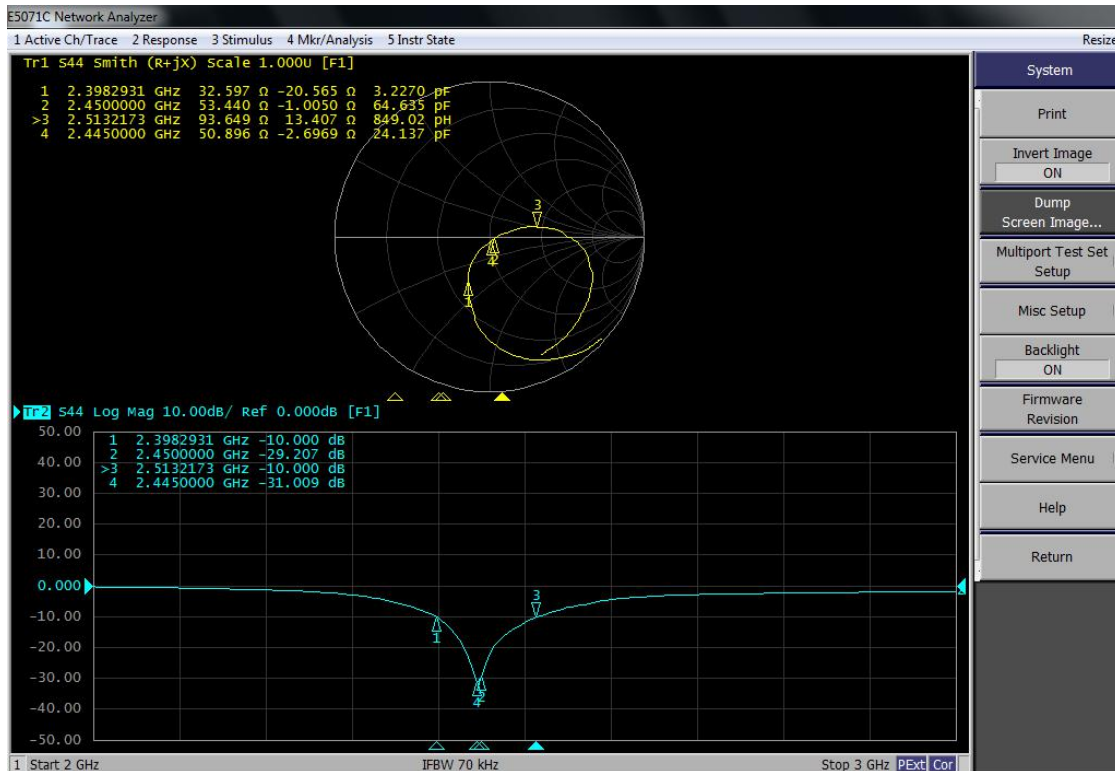

Radiation Pattern

coordinates:

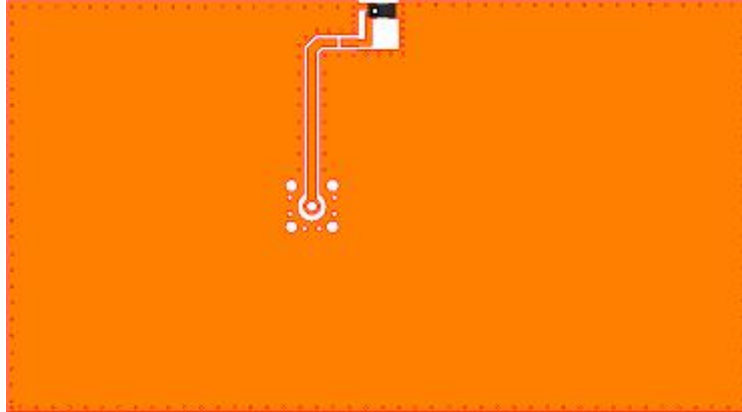
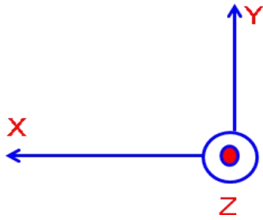

X-Z Plane

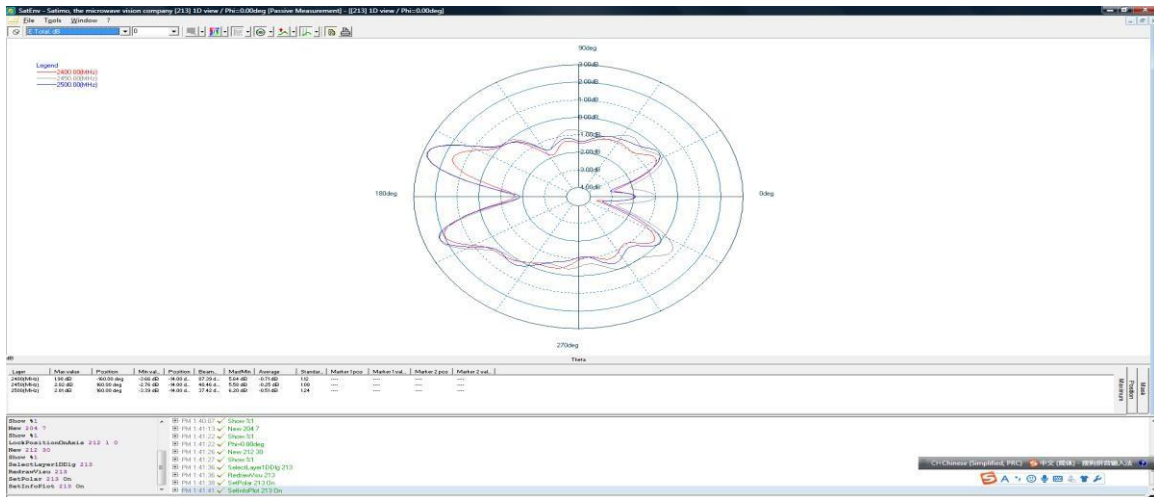

X-Y Plane

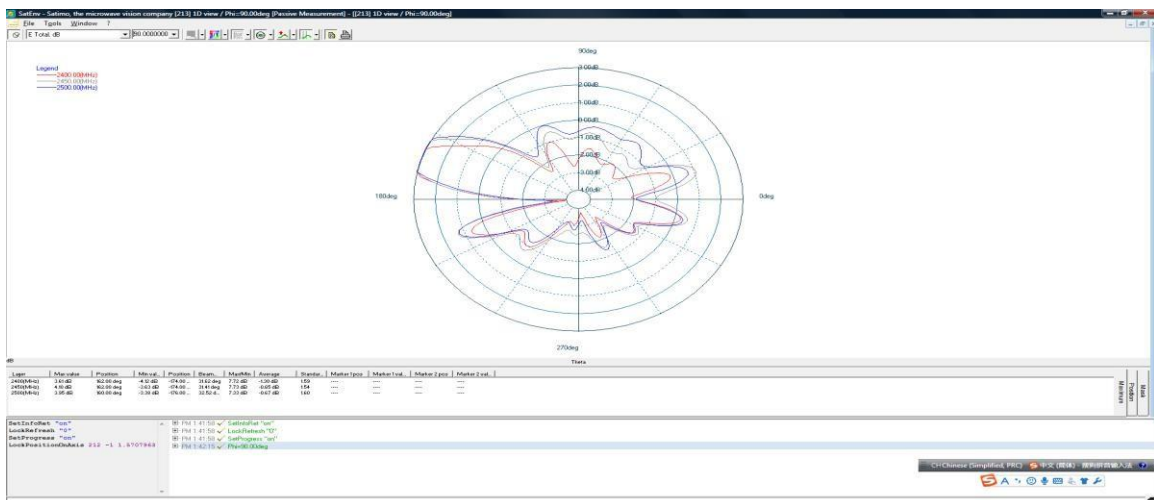

Y-Z Plane

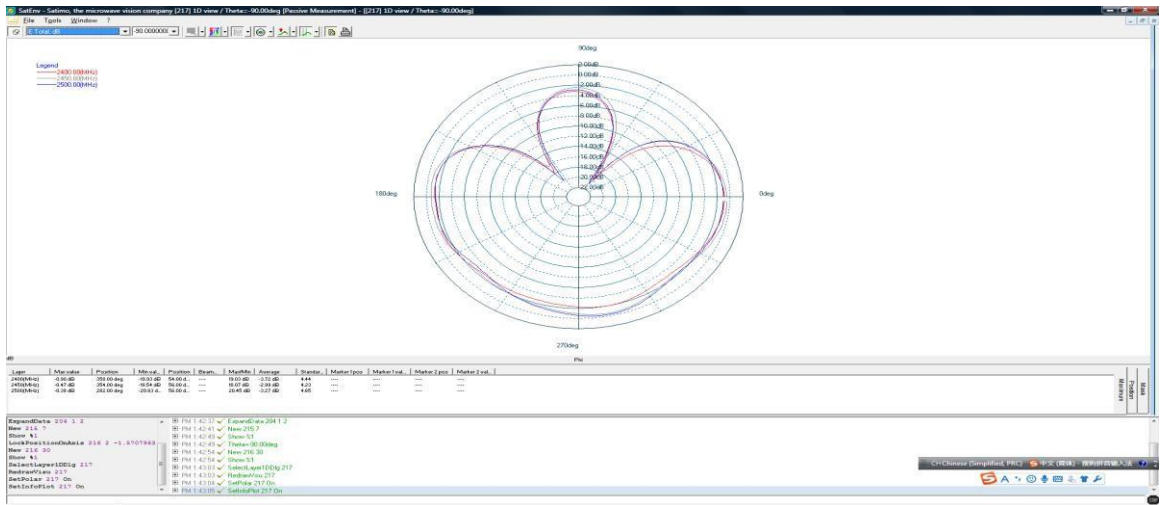

3D Radiation Pattern

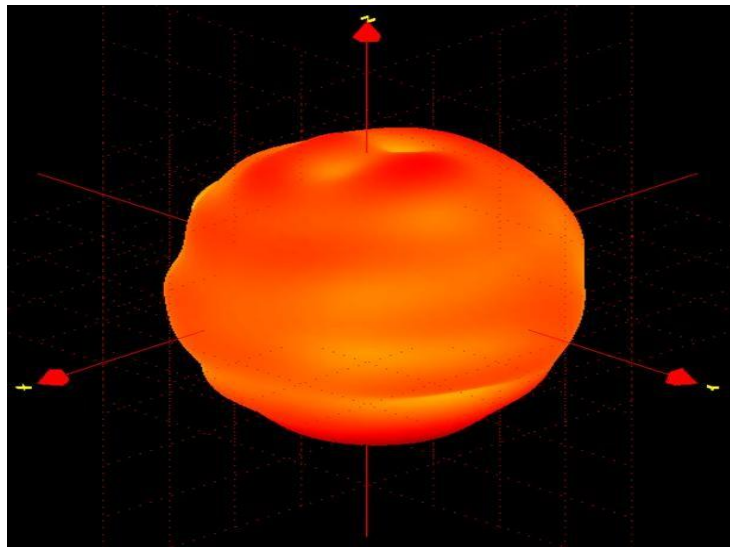

Frequency (MHz)	2400	2450	2500
Avg. Gain (dBi)	-1.91	-1.30	-1.48
Peck Gain (dBi)	1.76	4.08	5.54
Efficiency (%)	72.1	78.2	71.8

Dependability Test

Temperature range	25±5°C
Relative Humidity range	55~75%RH
Operating Temperature range	-40°C~+85°C
Storage Temperature range	-40°C~+85°C

Vibration Resist

The device should fulfill the electrical specification after applied to the vibration of 10 to 55Hz with amplitude of 1.5mm for 2 hours each in X , Y and Z directions.

Drop Shock

The device should have no mechanical damage after dropping onto the hard wooden board from the height of 100cm for 3 times each facet of the 3 dimensions of the device.

Solder Heat Proof

The device should be satisfied after preheating at 120°C~150°C for 120 seconds and dipping in soldering Sn at 255°C+10°C for 5±0.5 seconds, or electric iron 300°C-10°C for 3±0.5 seconds, without damage.

Adhesive Strength of Termination

The device have no remarkable damage or removal of the termination after horizontal force of 5N(≤0603); 10N(>0603)with 10±1 seconds.

Bending Resist Test

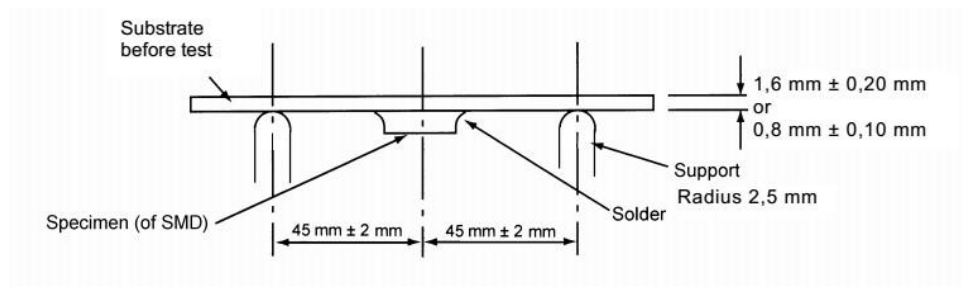

Weld the product to the center part of the PCB with the thickness 1.6±0.2mm or 0.8±0.1mm as the illustration shows, and keep exerting force arrow-ward on it at speed of 1mm/S, and hold for 5±1S at the position of 1.5mm bending distance, so far, any peeling off of the product metal coating should not be detected.

Moisture Proof

The device should fulfill the electrical specification after exposed to the temperature $60\pm 2^{\circ}\text{C}$ and the relative humidity 90~95% RH for 96 hours and 1~2 hours recovery time under normal condition.

High Temperature Endurance

The device should fulfill the electrical specification after exposed to temperature $85\pm 5^{\circ}\text{C}$ for 96 ± 2 hours and 1~2 hours recovery time under normal temperature.

Low Temperature Endurance

The device should fulfill the electrical specification after exposed to the temperature $-40^{\circ}\text{C}\pm 5^{\circ}\text{C}$ for 96 ± 2 hours and to 2 hours recovery time under normal temperature.

Temperature Cycle Test

The device should fulfill the electrical specification after exposed to the low temperature -40°C and high temperature $+85^{\circ}\text{C}$ for 30 ± 2 min each by 5 cycles and 1 to 2 hours recovery time under normal temperature.

Reflow Soldering Standard Condition

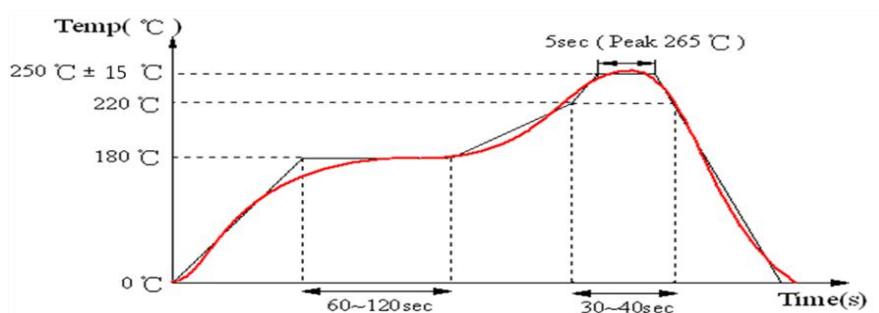

Packaging and Dimensions (3216)

Plastic Tape

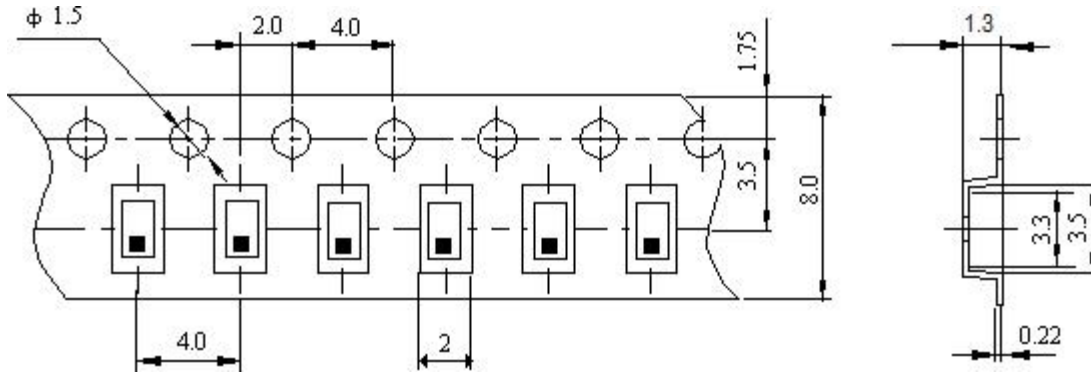

Remarks for Package

Reserve a length of 150~200mm for the trailer of the carrier and 250~300 mm for the leader of the carrier and further 250mm of cover tape at the leading part of the carrier.

Reel (3000 pcs/Reel)

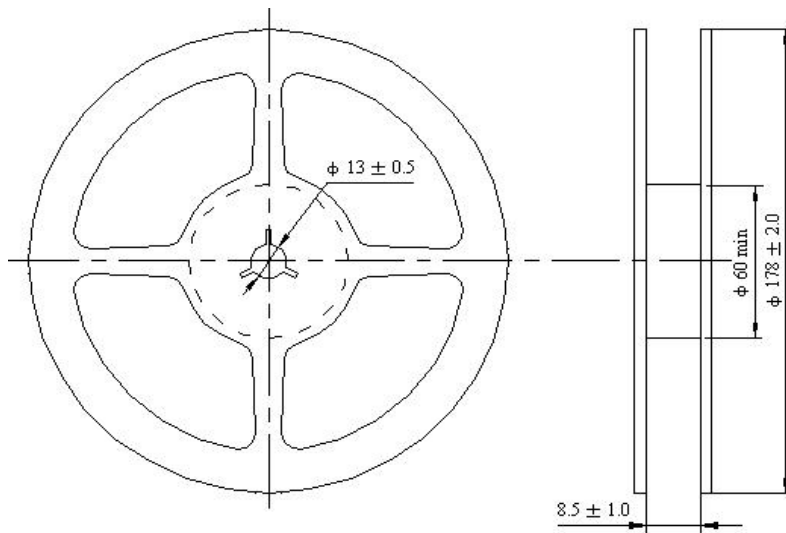

Storage Period

Product should be used within six months of receipt.

MSL 1 / Storage Temperature Range : <30 degree C, Humidity : <85%RH