

1

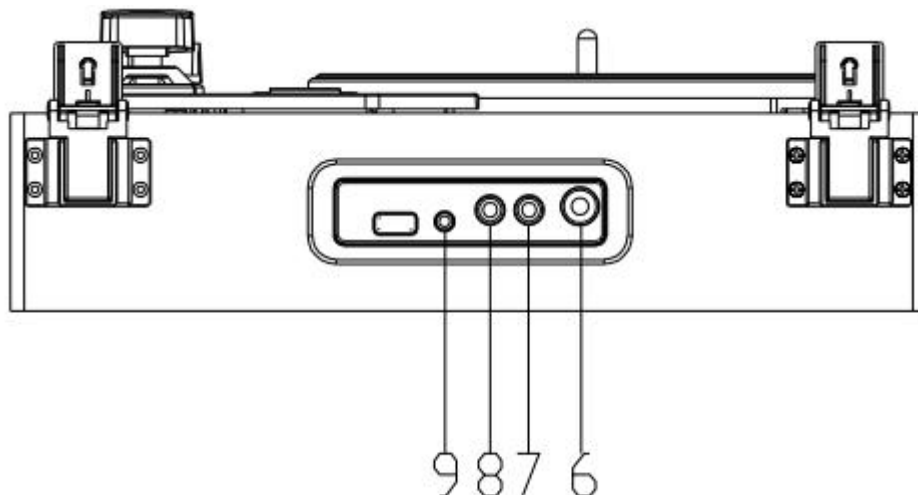

KD-2008LB
快速操作手册

- 1: 自停调节开关键，将开关打到 ON 状态，LP 播放有自停功能，开关打到 OFF 状态后，LP 无自停功能。
- 2: 三速调节开关，拨动此开关，对应 LP 唱盘有 33 45 和 78 三种转速。
- 3: 音量开关电位器，顺时针方向旋转为开机和音量调大，逆时针方向旋转为调小音量和关机。
- 4: 耳机插座：插入 3.5mm 耳机。
- 5: LED 指示灯，在不同工作状态，显示不同的颜色和状态：（蓝牙配对状态为快速闪烁，

配对成功后暂停和未播放时为慢速闪烁，播放时为蓝灯长亮；AUX IN 接入后蓝灯长亮；LP 工作状态为绿灯长亮。

6: DC 插座：直流电源输入接口。

7 8: 14: RCA 输出接口：外放输出接口。

9: AUX IN 输入接口：音频输入接口。

简易操作：

1. 将 3 顺时针旋转开机并调节音量到合适的位置。此时有蓝牙搜索语音提示，此时蓝灯快速闪烁，蓝牙处于配对状态。

打开蓝牙发射设备搜索蓝牙，出现“CODI”点击配对，配对成功后，本机会有语音提示。

2: 将 AUX IN 插入连接线，此时有语音提示。

3: 将唱杆放置于唱盘上，本机自动切换到 LP 模式，此时绿灯长亮。

4: 将耳机插入耳机孔，此时外放喇叭无声，为耳机模式。

5: 插入外接播放连接线对应 7 8 两处接入有源音箱，本机声音可以进行其它音箱播放，音量调节钮可以调节音量大小。

WOCKODER

LP&BLUETOOTH MODE SWITCHED AUTOMATICALLY

TURNTABLE PLAYER

OPERATING INSTRUCTIONS

Made In China

www.codi-tech.net

Thanks for purchasing this player

Feel free to enjoy our Turntable Player

Known our player highlight function

.LP music:3 speed LP with 7" ,10",12" size record

.Bluetooth:Freely listening our player music from external Bluetooth speaker by our Bluetooth receiving device **Out function or RCA function**

.LP&BLUETOOTH MODE SWITCHED AUTOMATICALLY

.Voice prompts for Bluetooth status:The Bluetooth device is ready to pair.

.Voice prompts for LP:Di dong

.Voice prompts for AUX in: Aux in put mode

Let us start to enjoy now

General of Instruction

Please read this manual carefully before using the product to ensure proper use. Keep this manual in a safe place for future reference.

.What is included in the package

.Know our product structure and component

.Know our playing function

.How to play LP, Bluetooth ,Aux in and RCA out

.Turntable specification

.Know replacing the turntable stylus

.Warranty Card

Safety Instruction

This product has been well-tested and adjusted, and strict examination of its quality before allowed to leave the factory. Please check and follow the manual instructions carefully. Any neglect, misuse, abuse, accident, failures caused by software problem, modify without WOCKODER authorized, power surges, and any loss or damage arising out of circumstances beyond WOCKODER'S control, we will not be responsible for the result.

What is included in the package

After you open the package, Please check the items as below carefully before being used.

1. Turntable player KD-2008LB:1pcs 唱片机一台

2. Operation Manual:1pcs 说明书一份

3. **DC adaptor 5V 1.5A:1pcs** **5V 1A 的电源适配器一个**

Know our product structure and component

1. Dust cover 盖子
2. Turntable player 机身
3. 45RPM fixator 调节器
4. Tone Arm 唱杆
5. Tone Arm Raise Lever 唱杆提升杆
6. Tone Arm Clip 唱杆夹子
7. Stylus 唱针
8. Auto Stop Switch 自动启停开关
9. LP Speed Switch 转速开关
10. Power on/off and volume control 开关、音量控制
 - Short time knob press to power on
 - Long time knob press to power off
 - Rotate L/R to turn up/down the volume
11. Headphone jack 耳机插孔
12. Light indicator 指示灯
13. Power adaptor jack 电源适配器插孔
- 7&8. RCA output jack (for active speaker) RCA 插孔
10. Aux in jack Aux in 插孔

Know our playing function

After connect the power adaptor, press the Power button (), the player starts to work while voice reminding and LED blue light. Please refer to below description to better operate.

How to play Bluetooth:

Bluetooth play mode: Bluetooth mode as default. Press the Power button (), the player starts to work while voice reminding and LED blue light flash () quickly. You can hear the voice: "The Bluetooth device is ready to pair." Once paired, the Blue light flash slowly. The lovely songs on your Bluetooth device will be transferred to turntable to sound and control.

How to play LP:

LP disk play mode: It shows enter to LP mode successfully once you can hear the voice "Di dong". Then place a LP disk on the turntable platter and select the desired speed (33/45/78) by sliding the speed selection switch () according to the LP disk specification. Open the tone arm clip () to release the arm upon the LP disk, and push the Arm Raise Lever () backwards to raise the arm. Gently move the tone arm () to the desired slowly, then close the arm clip ().

Note: When the auto stop switch is turned on, the turntable will continue to spin no matter LP playing or not.

Warning: Do not manual lower the tone arm onto the LP disk, to avoid LP disk and stylus () damage!

How to use Aux in:

Audio JACK /Aux in play mode: Using a right Aux in line to connect between your playing device without Bluetooth and our player **Aux in jack()** on the back panel. Then the sound will be transferred from another playing device to our player.

How to use RCA out:

RCA output Jack/Connect to speaker: Using a right audio date line to connect between your external speakers(active speakers only)and our player RCA out jack on the back panel. Then the sound will be transferred from turntable to your lovely external active speakers. Warmly note,our player sound still be spoke out.

Turntable specification

Item	Specification
Bluetooth version	V4.2
Bluetooth effective range	≅10m
Frequency response range	120Hz—16kHz
Charging function	USB charging 5V
Speaker output power	5W×2
Speaker impedance	4 Ω
Operating temperature range	-10℃—+40℃
Adaptor	DC5V 1.5A

How to replace the turntable **stylus()**

Removing the stylus from the Tone Arm Clip()

Place a screwdriver at the tip of the stylus and push downward as shown in direction "A"

1. WARNING:When applying force to stylus too much may damage or break the stylus.
2. Remove the stylus by pulling the stylus forward and pushing downward.

Installing the stylus

1. Hold the tip of the stylus and insert the stylus by pressing as shown in direction "B"
2. Push the stylus upwards as in direction "C"until the stylus locks into the tip position.

WOCKODER

Light indicator instruction

Light indicator color	Working status
LED Blue light flash quickly	search for Bluetooth
Blue light flash slowly	Bluetooth mode connected
Blue light flash slowly	Pause status
blue	Bluetooth play mode
Green	LP disk play mode
blue	Aux in play mode

NOTE:Light Flash Max or Min reached

Operation Details & Quick instruction

When there is no play from Bluetooth or Aux in,the player will automatically shut down after 10 mins.Please kindly rotate the Power Button(12)back to the initial position,and restart the player after 5 sec.

While the turntable player has no work in Bluetooth mode or Aux in mode for ten minutes,it will be entered into Automatic shutdown state.

If you want to enjoy your music again,You should Restart the turntable after 5 seconds.

LP disk play mode: The player will automatically switch to LP disk play mode once rise the Tone Arm(5), and voice prompts as "Di Dong" to indicate that it entered into LP play mode successfully.

Please kindly follow below instruction to play /stop to play the LP disk:

1. Place a LP disk on the turntable platter and select the desired speed(33 1/3 /45/78) by sliding the speed selection switch according to the LP disk spec.
2. Play the LP disk: Open the tone arm clip to release the tone arm. Push the lift lever backwards to raise the arm. Gently move the tone arm to the desired slowly onto the desired position on the LP disk to begin playing.
3. Stop the LP disk: Push the lift lever backwards to raise the arm, gently move the tone arm to the tone arm clip. Push the lift lever forward and lower the arm slowly, then close the tone arm clip.

Note: When the auto stop switch is turned on, the turntable will continue to spin no matter LP playing or not.

This device complies with Part 15 of the FCC Rules. Operation is subject to the following two conditions: (1) this device may not cause harmful interference, and (2) this device must accept any interference received, including interference that may cause undesired operation

NOTE: This equipment has been tested and found to comply with the limits for a Class B digital device, pursuant to Part 15 of the FCC Rules. These limits are designed to provide reasonable protection against harmful interference in a residential installation. This equipment generates, uses and can radiate radio frequency energy and, if not installed and used in accordance with the instructions, may cause harmful interference to radio communications. However, there is no guarantee that interference will not occur in a particular installation.

If this equipment does cause harmful interference to radio or television reception, which can be determined by turning the equipment off and on, the user is encouraged to try to correct the interference by one or more of the following measures:

- Reorient or relocate the receiving antenna.
- Increase the separation between the equipment and receiver.
- Connect the equipment into an outlet on a circuit different from that to which the receiver is connected.
- Consult the dealer or an experienced radio/TV technician for help.

Warning: changes or modifications not expressly approved by the party responsible for compliance could void the user's authority to operate the equipment