

Date: 24.MAY.2021 08:59:48

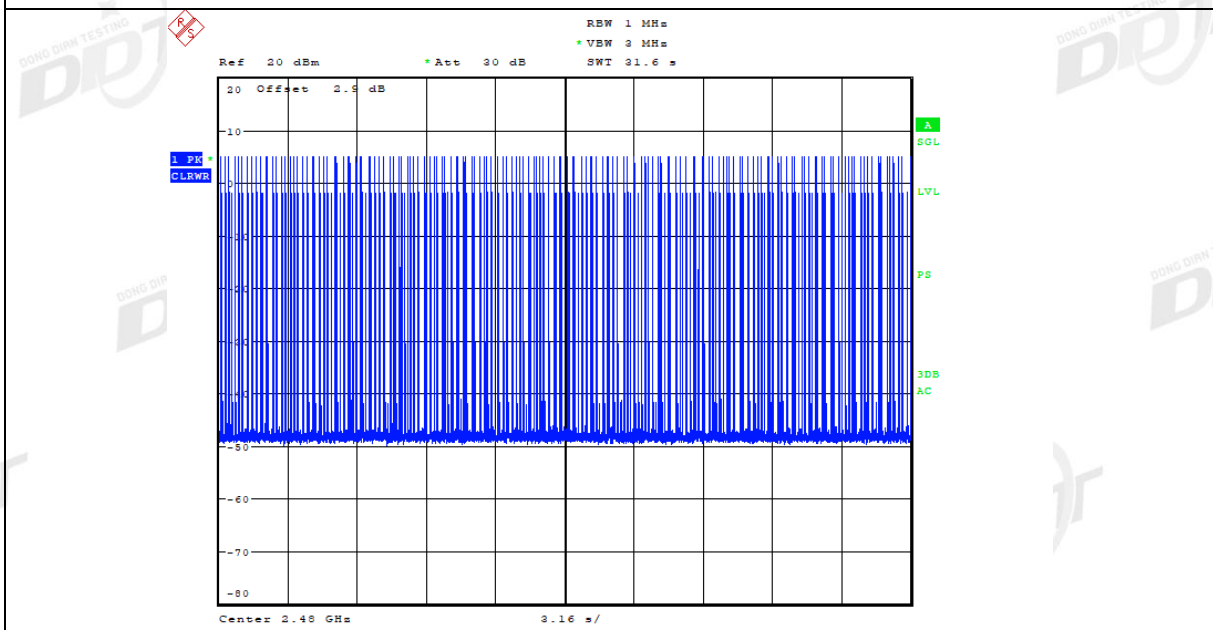

Date: 24.MAY.2021 09:00:21

2DH5\_Ant1\_Hop\_Low

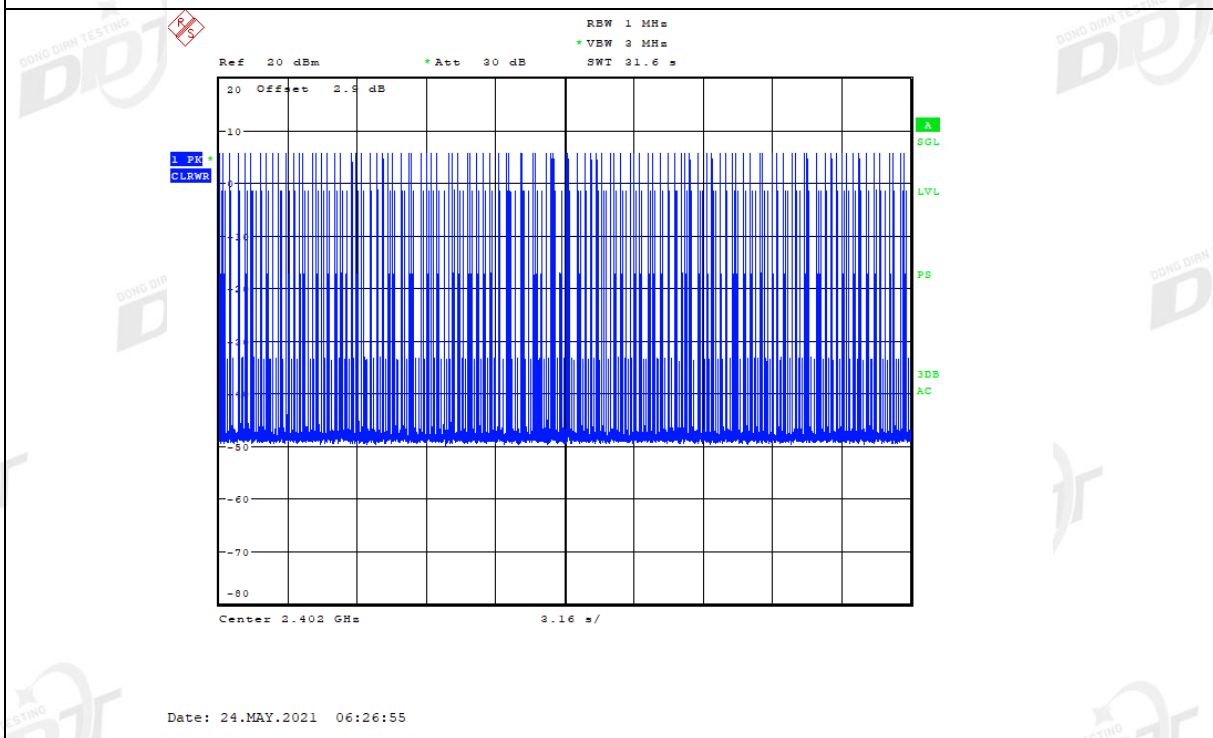
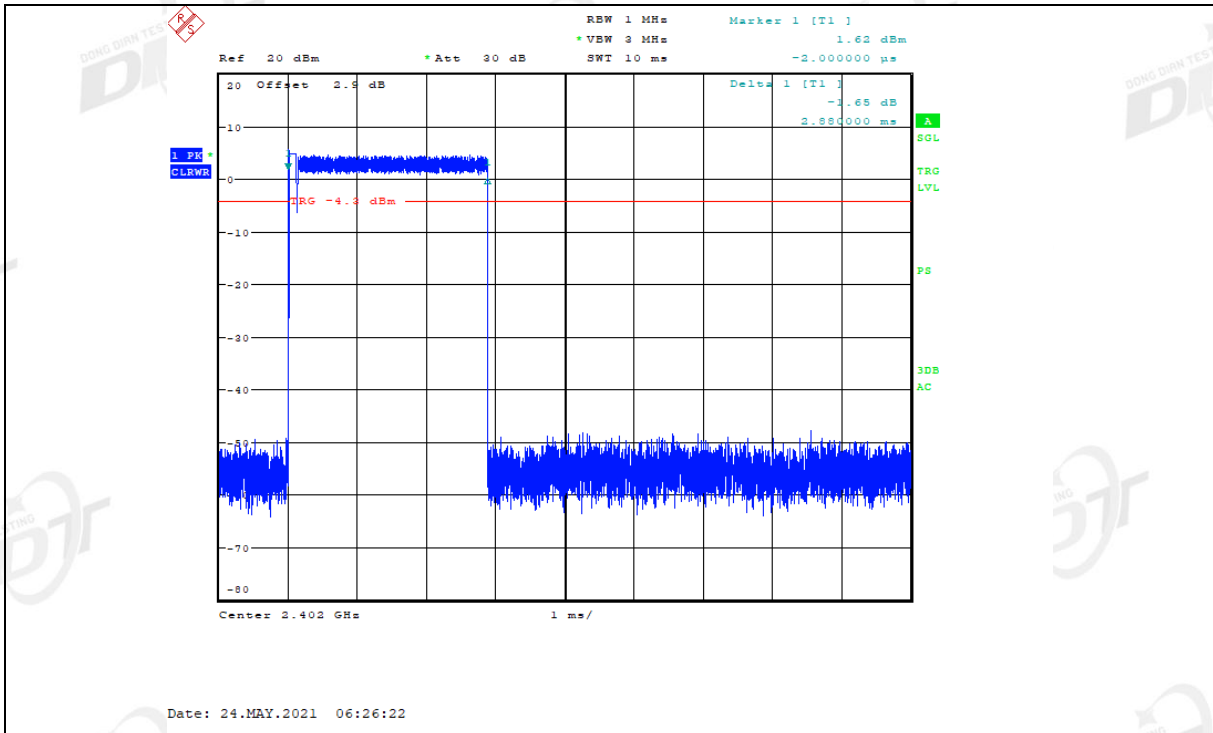

2DH5\_Ant1\_Hop\_Mid

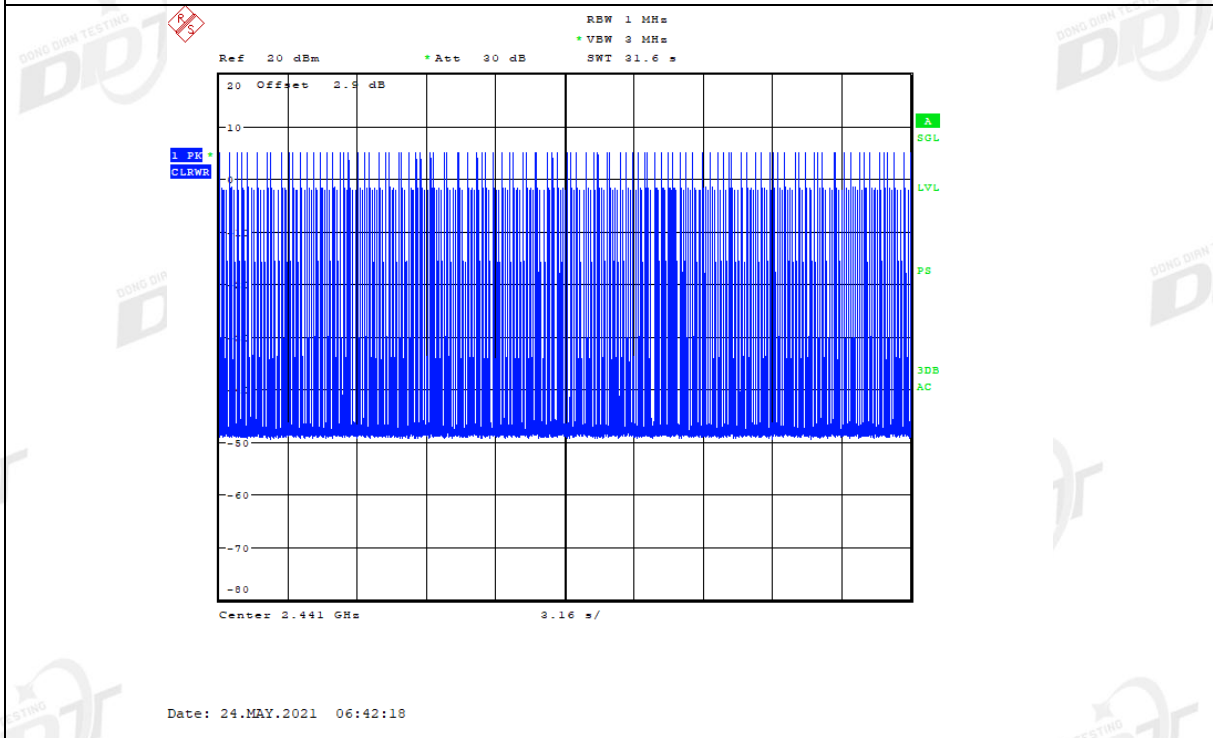
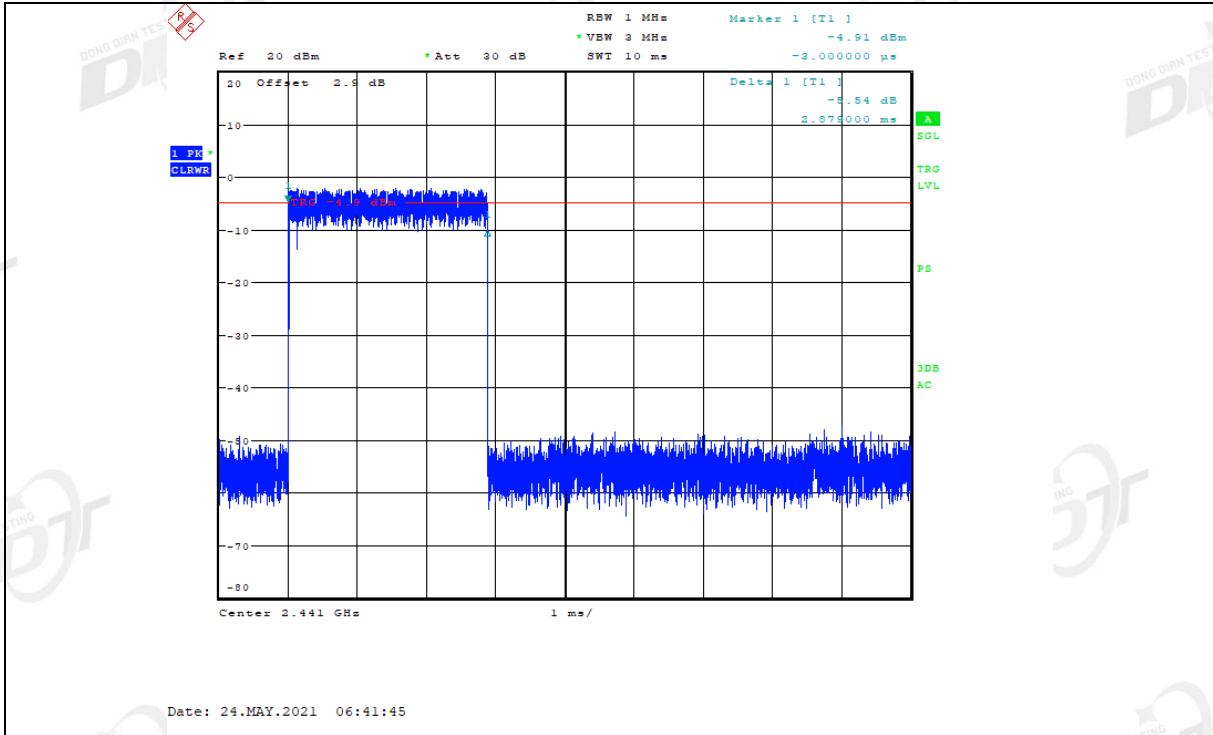

2DH5\_Ant1\_Hop\_High

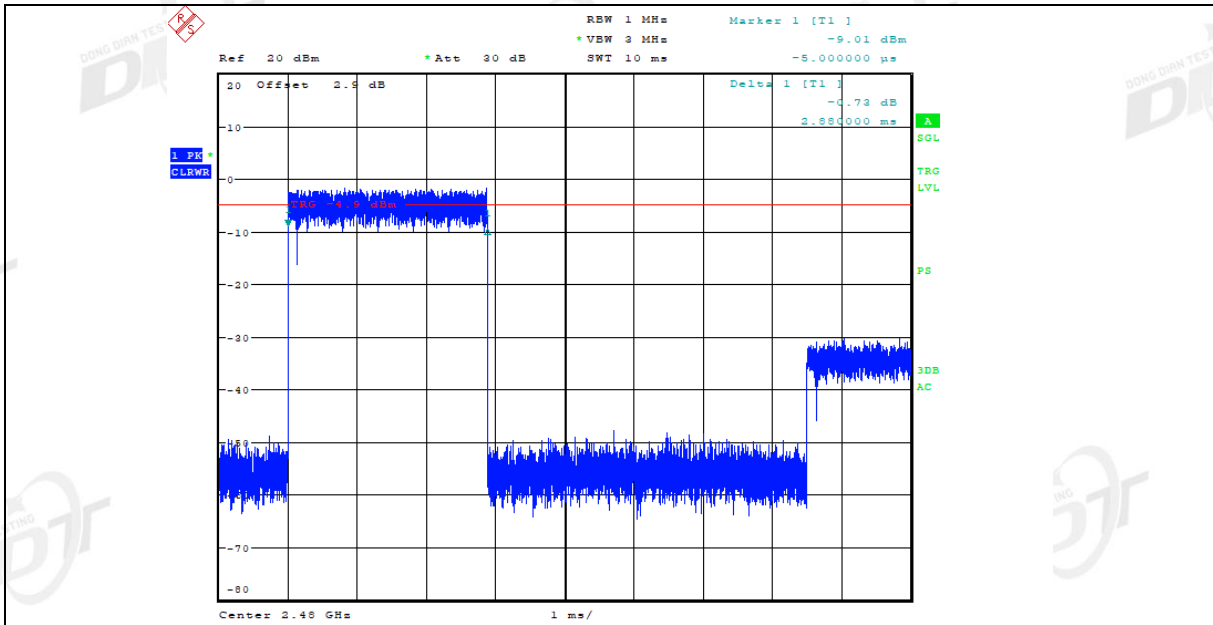

Date: 24.MAY.2021 07:17:15

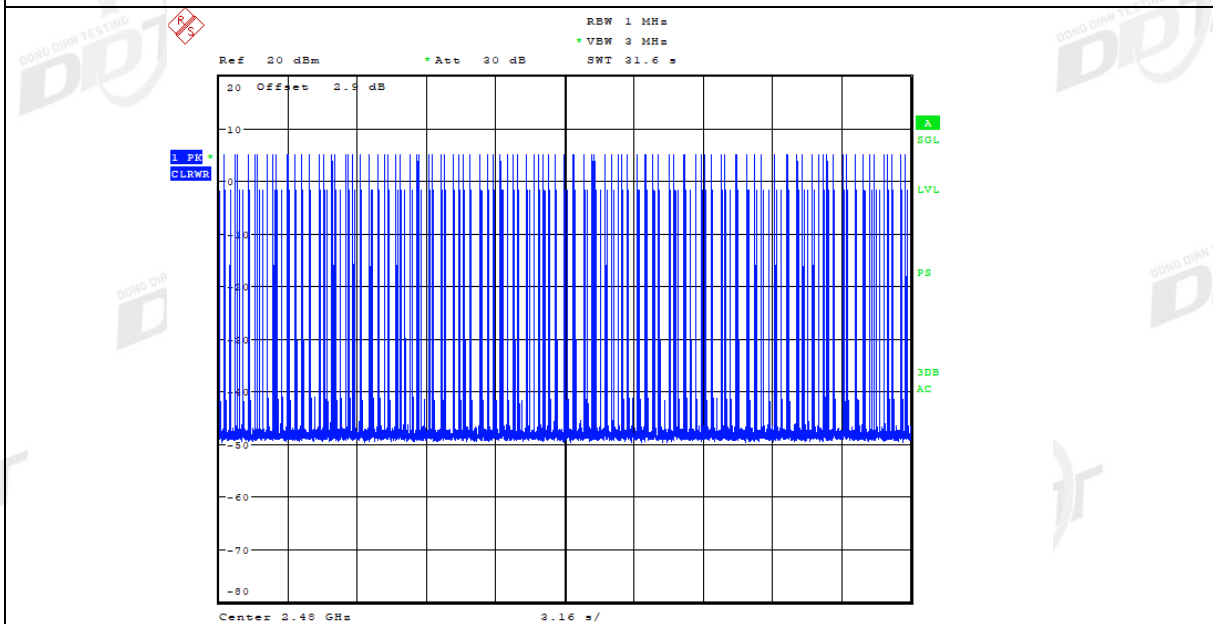

Date: 24.MAY.2021 07:17:48

3DH1\_Ant1\_Hop\_Low

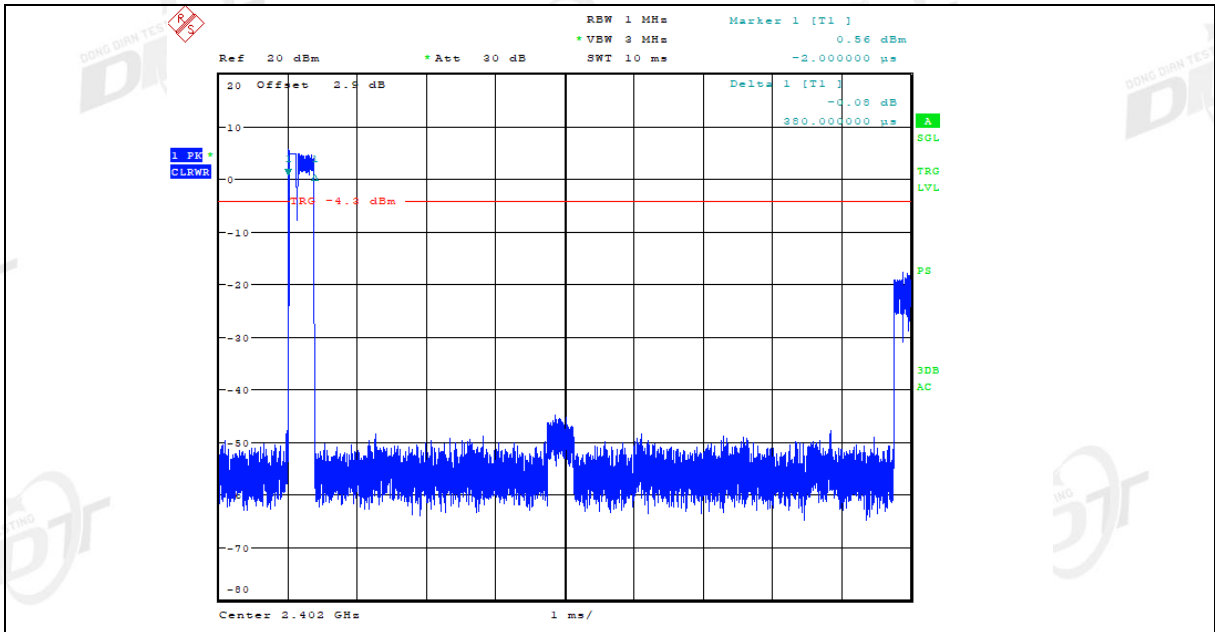

Date: 24.MAY.2021 09:01:45

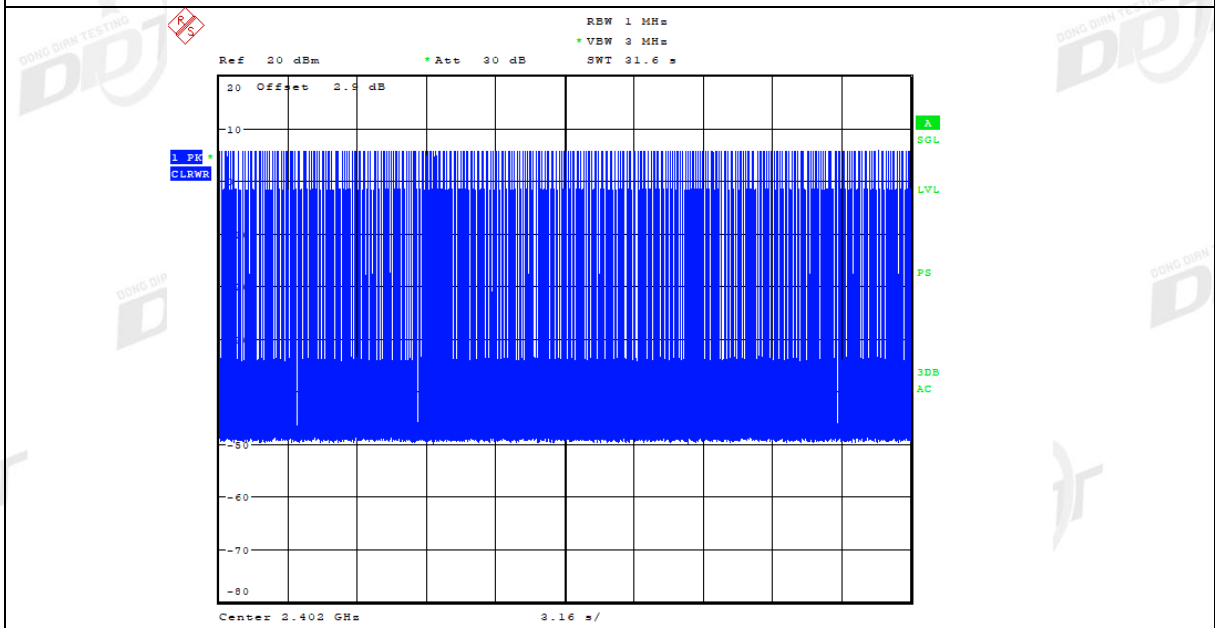

Date: 24.MAY.2021 09:02:18

3DH1\_Ant1\_Hop\_Mid

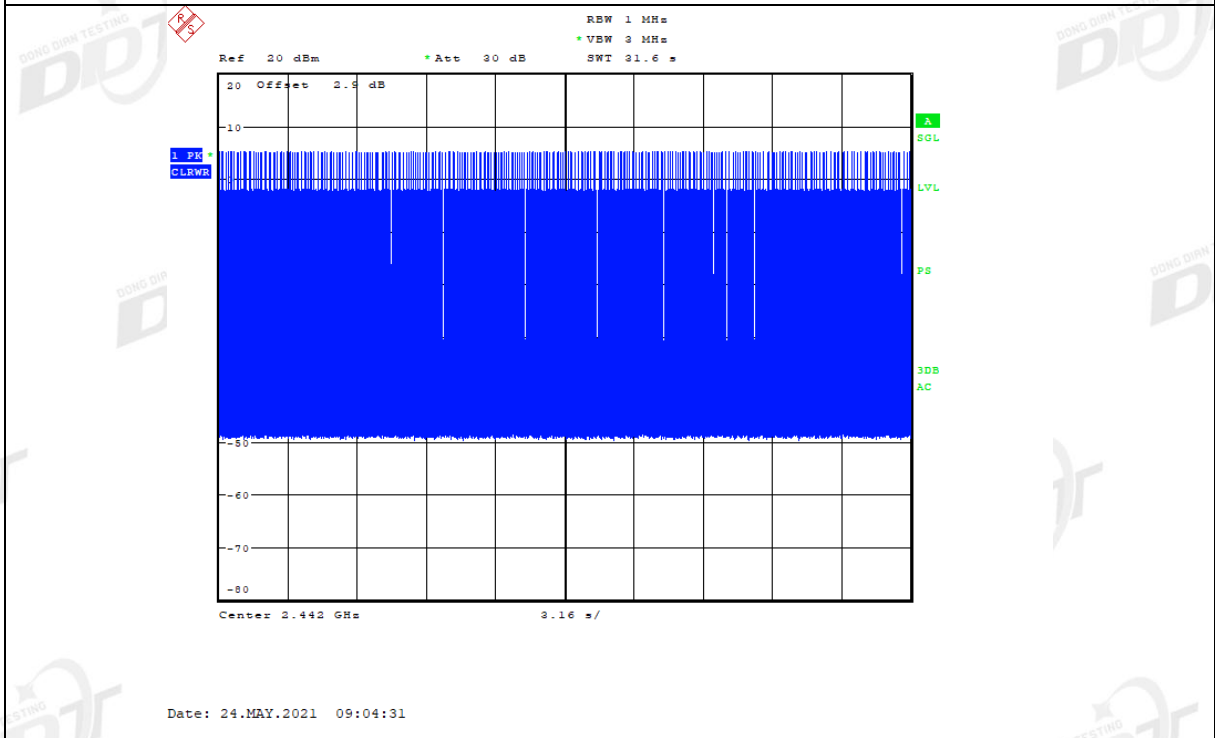
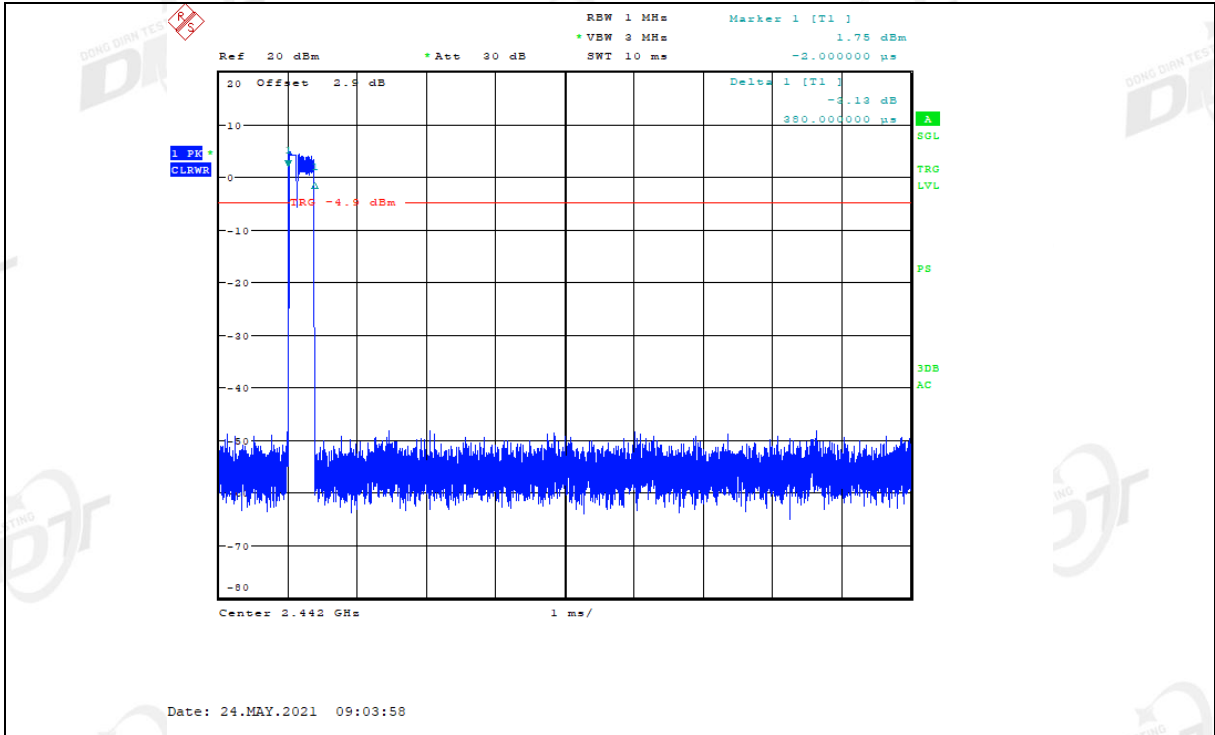

3DH1\_Ant1\_Hop\_High

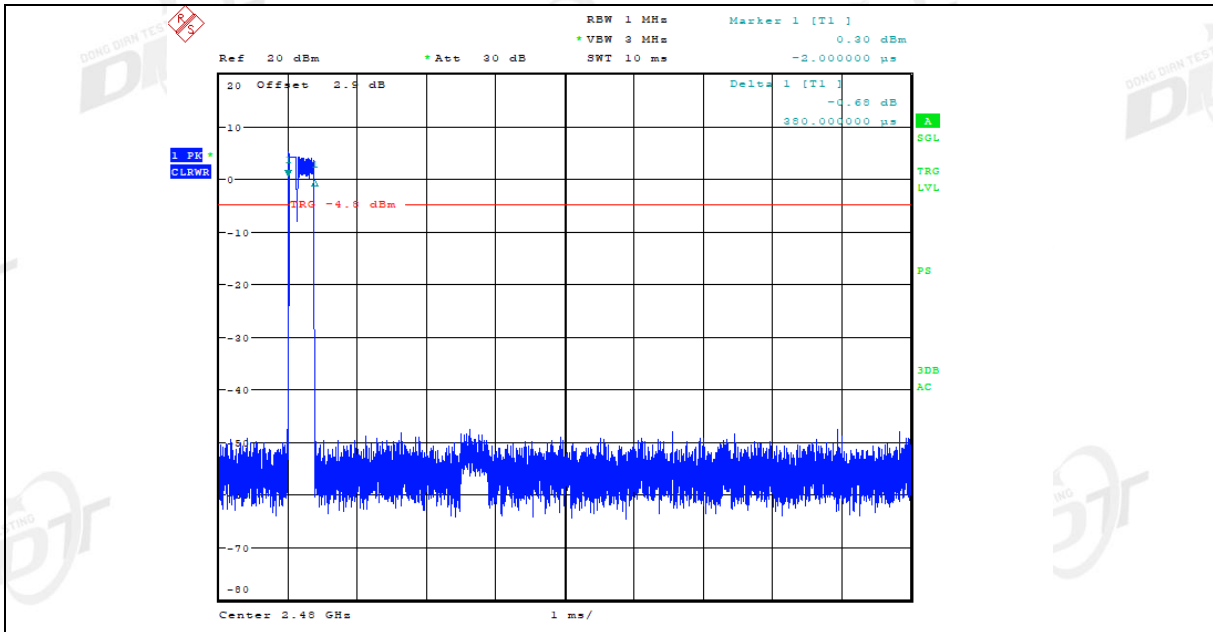

Date: 24.MAY.2021 09:04:41

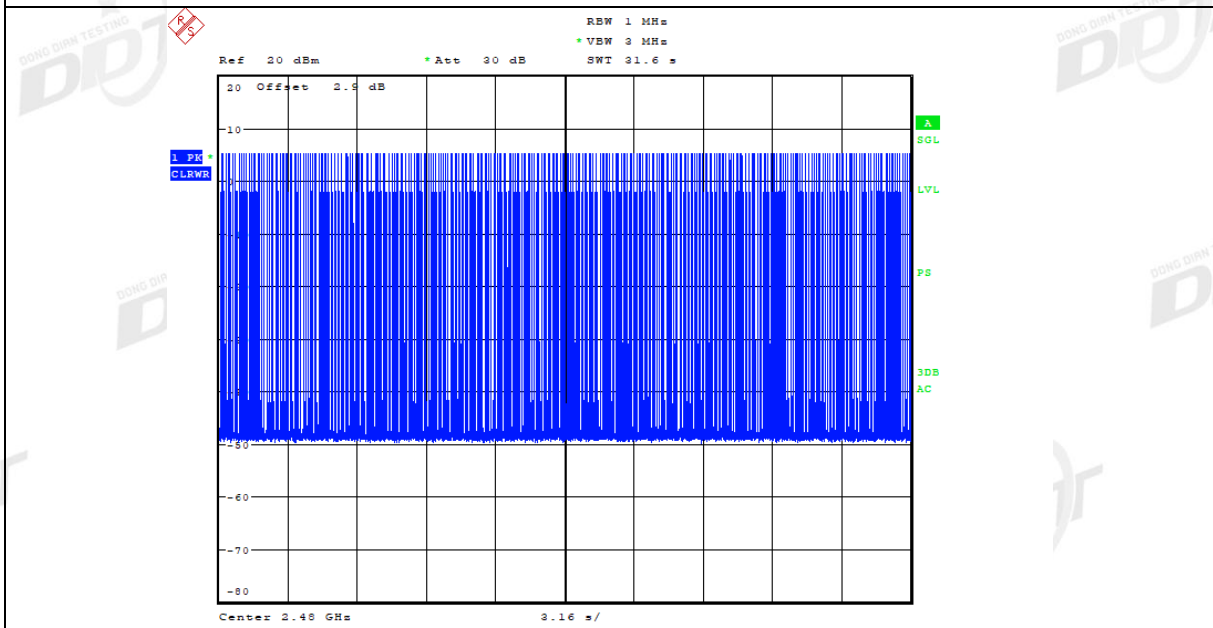

Date: 24.MAY.2021 09:05:14

3DH3\_Ant1\_Hop\_Low

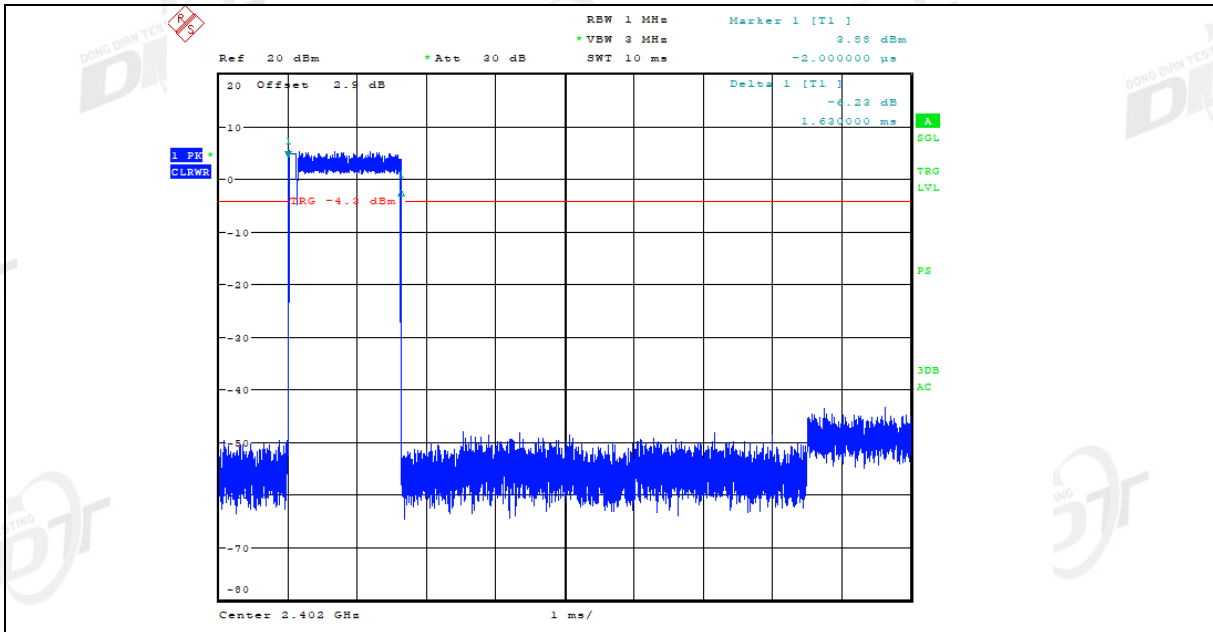

Date: 24.MAY.2021 09:07:18

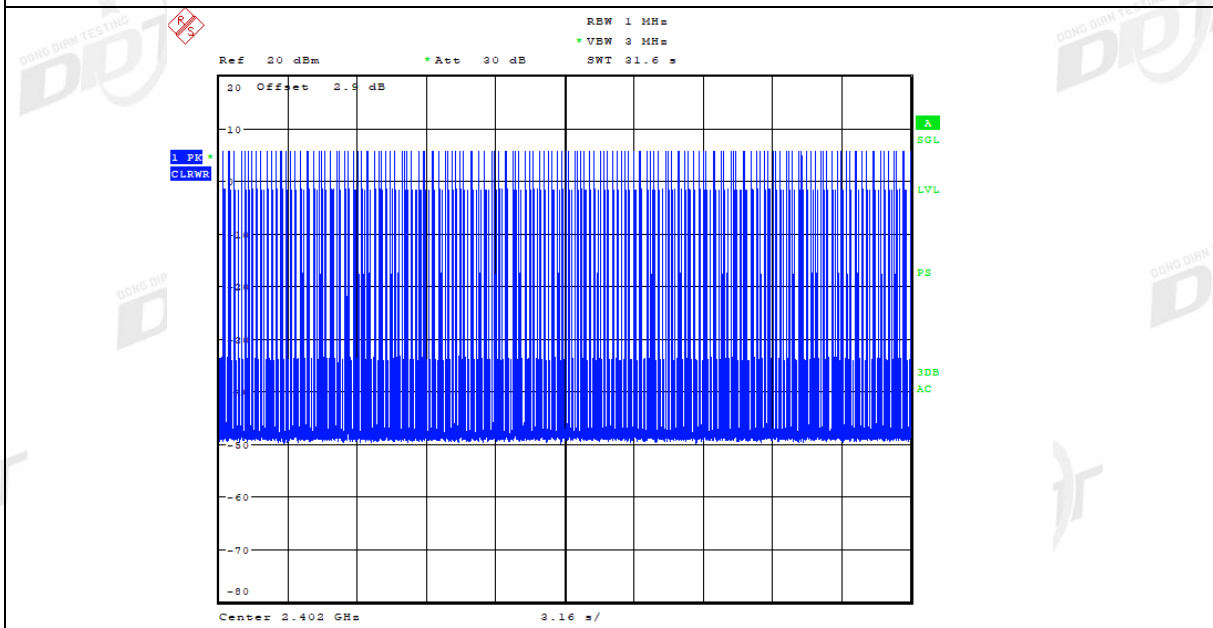

Date: 24.MAY.2021 09:07:51

3DH3\_Ant1\_Hop\_Mid



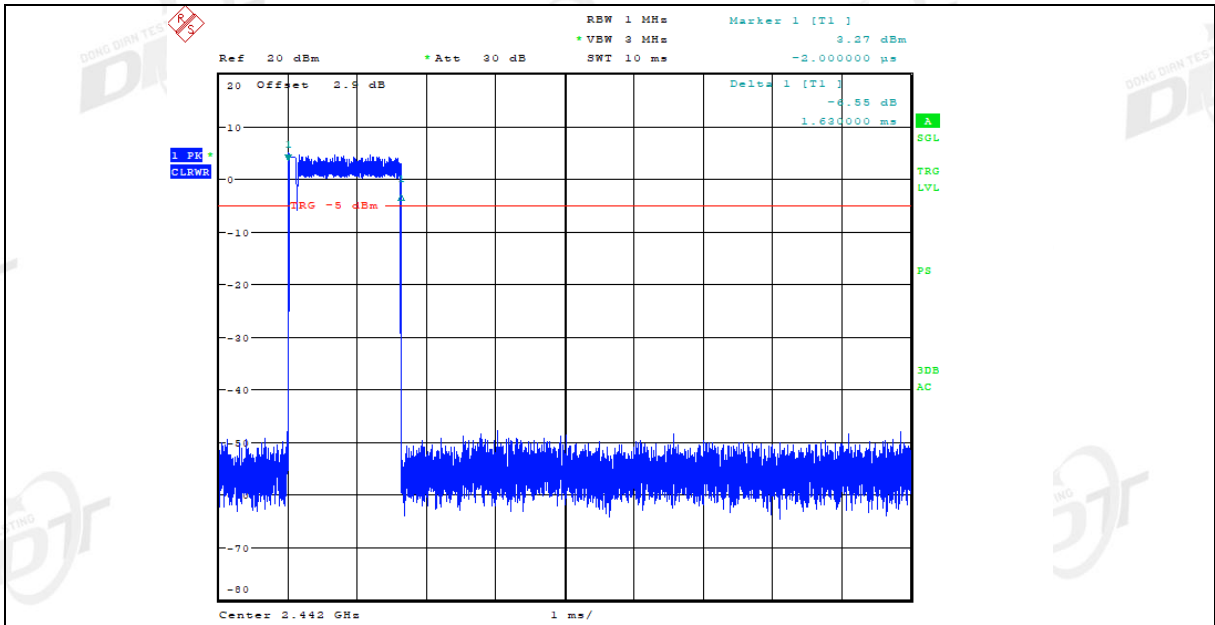

Date: 24.MAY.2021 09:09:19

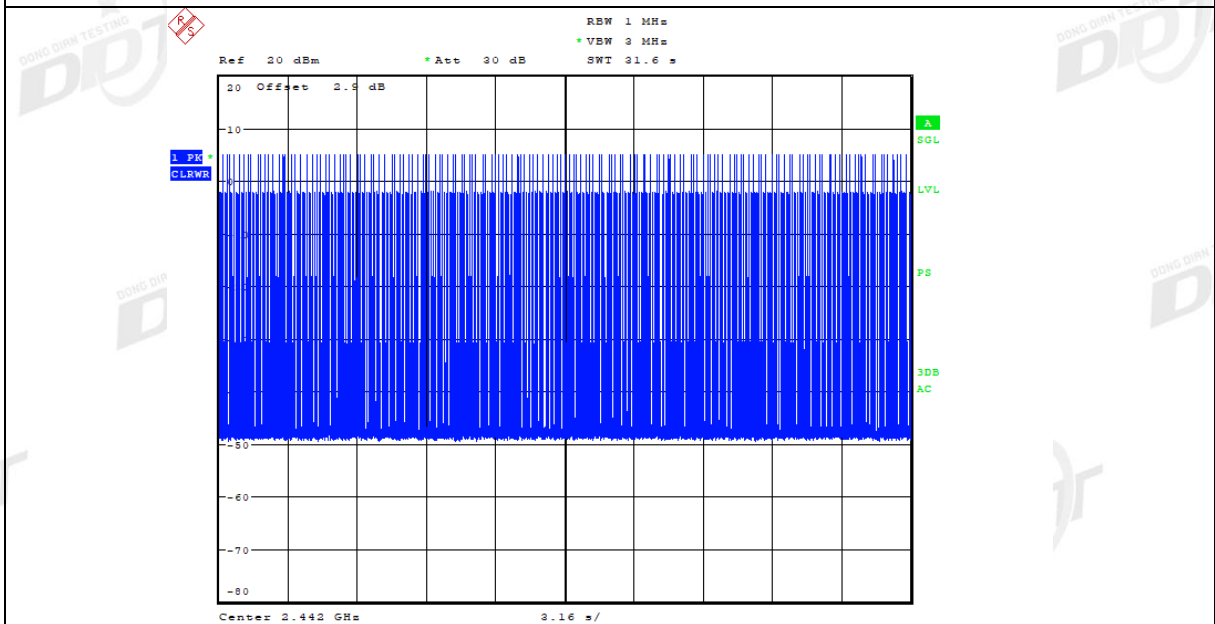

Date: 24.MAY.2021 09:09:52

3DH3\_Ant1\_Hop\_High

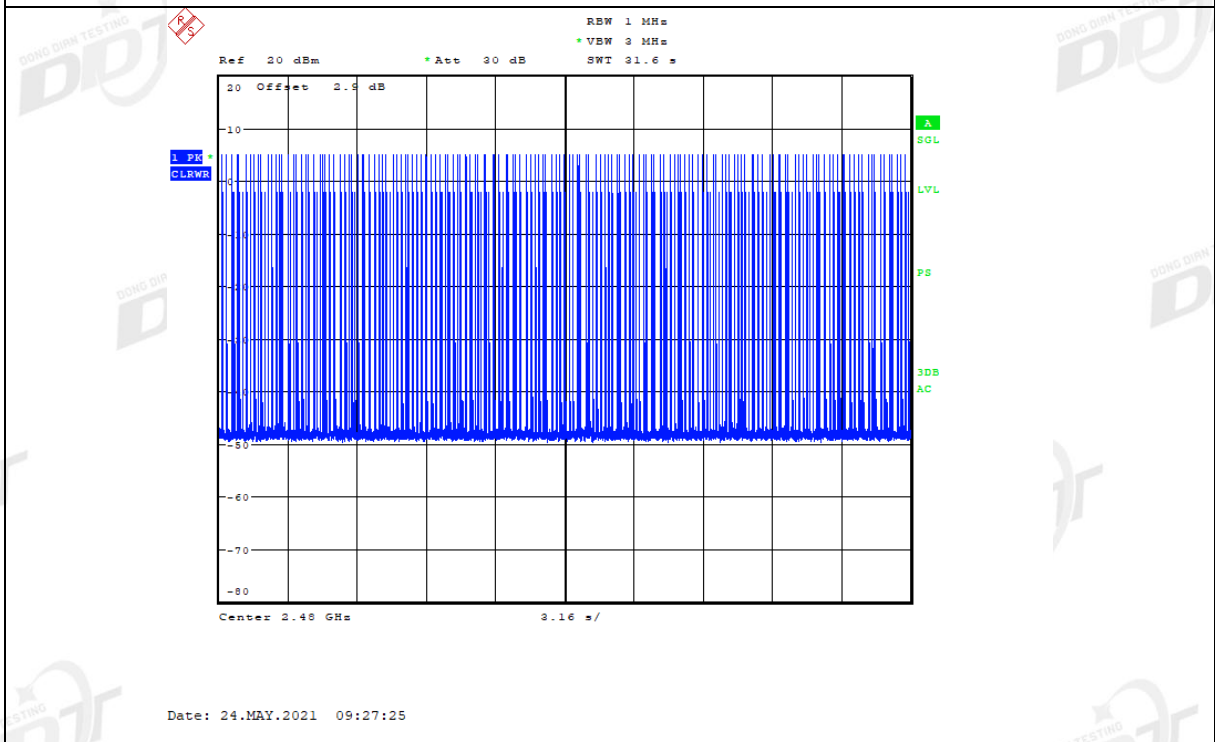
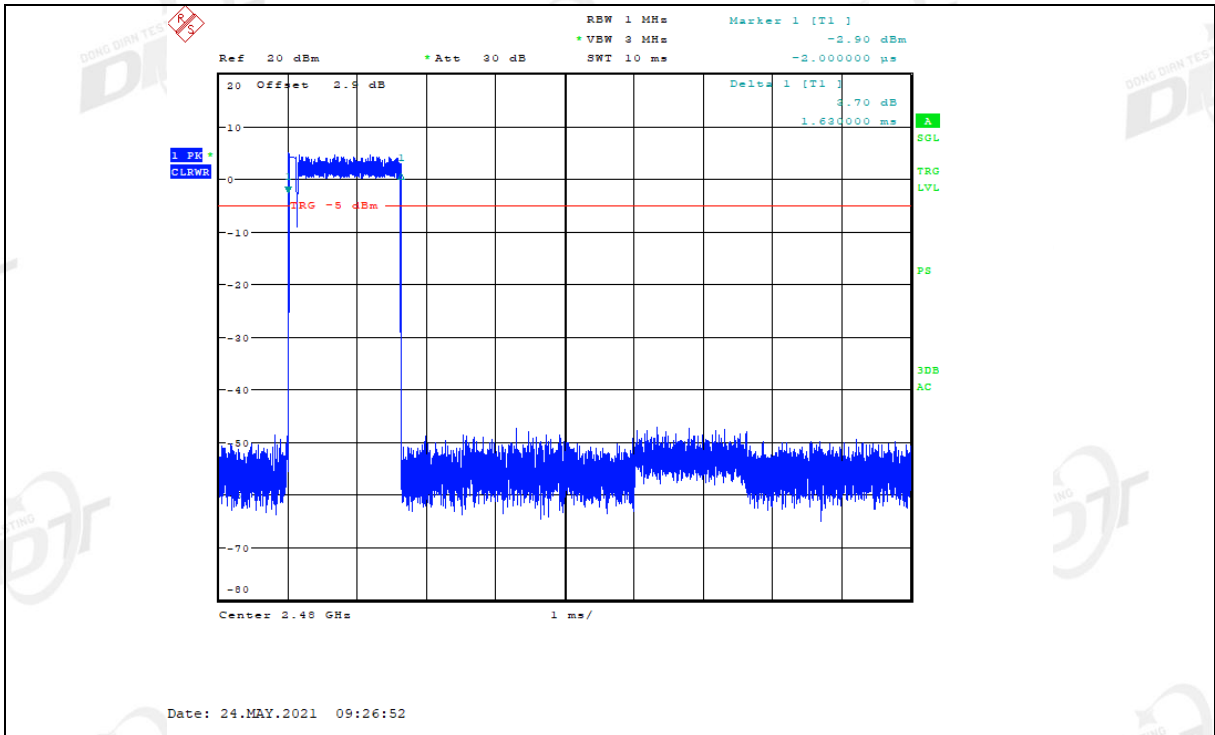

3DH5\_Ant1\_Hop\_Low

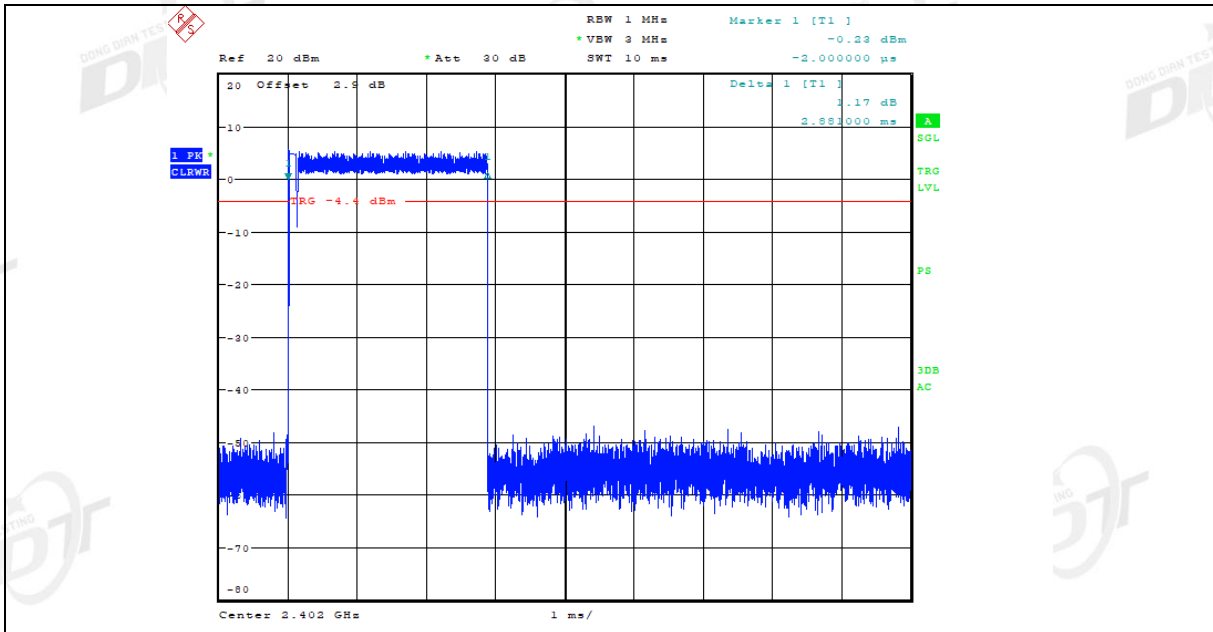

Date: 24.MAY.2021 07:31:20

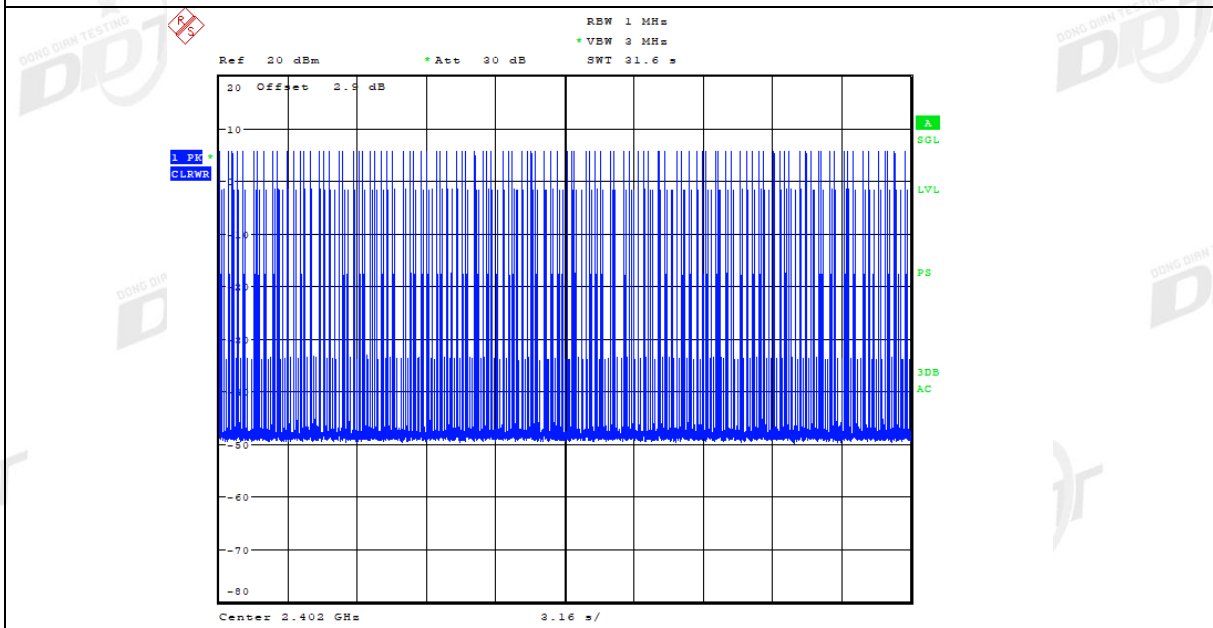

Date: 24.MAY.2021 07:31:52

3DH5\_Ant1\_Hop\_Mid

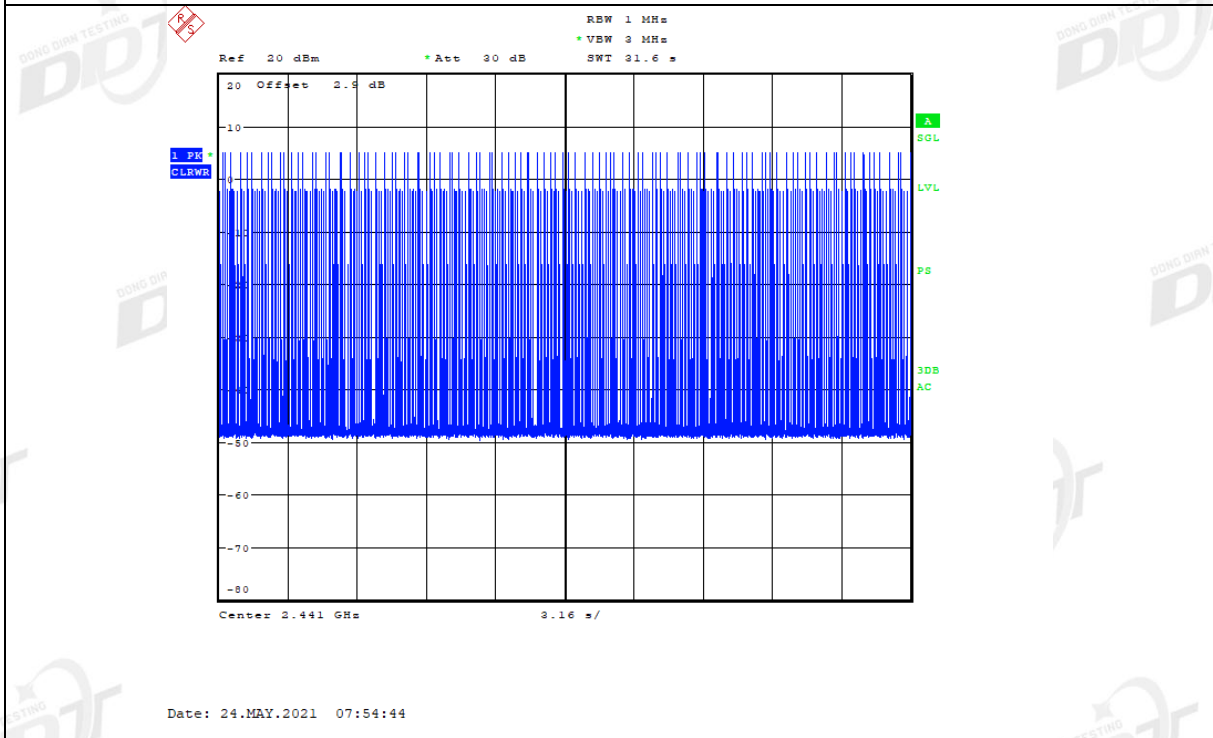
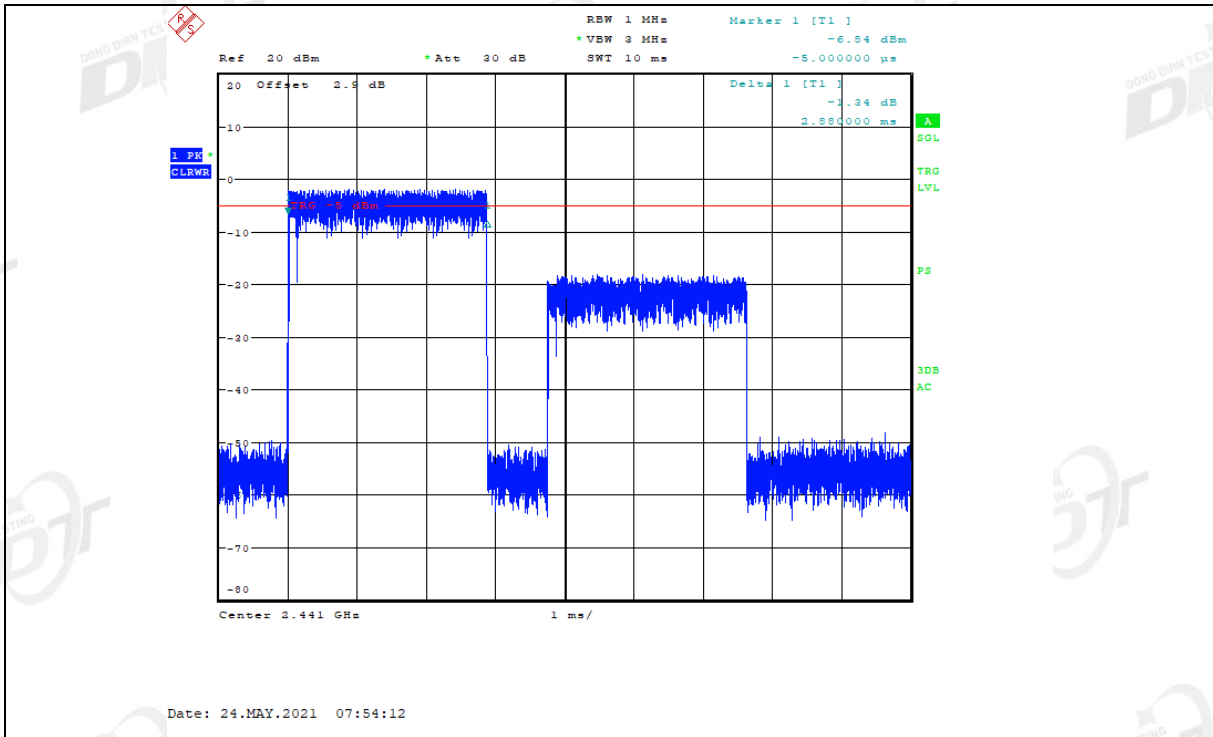

3DH5\_Ant1\_Hop\_High

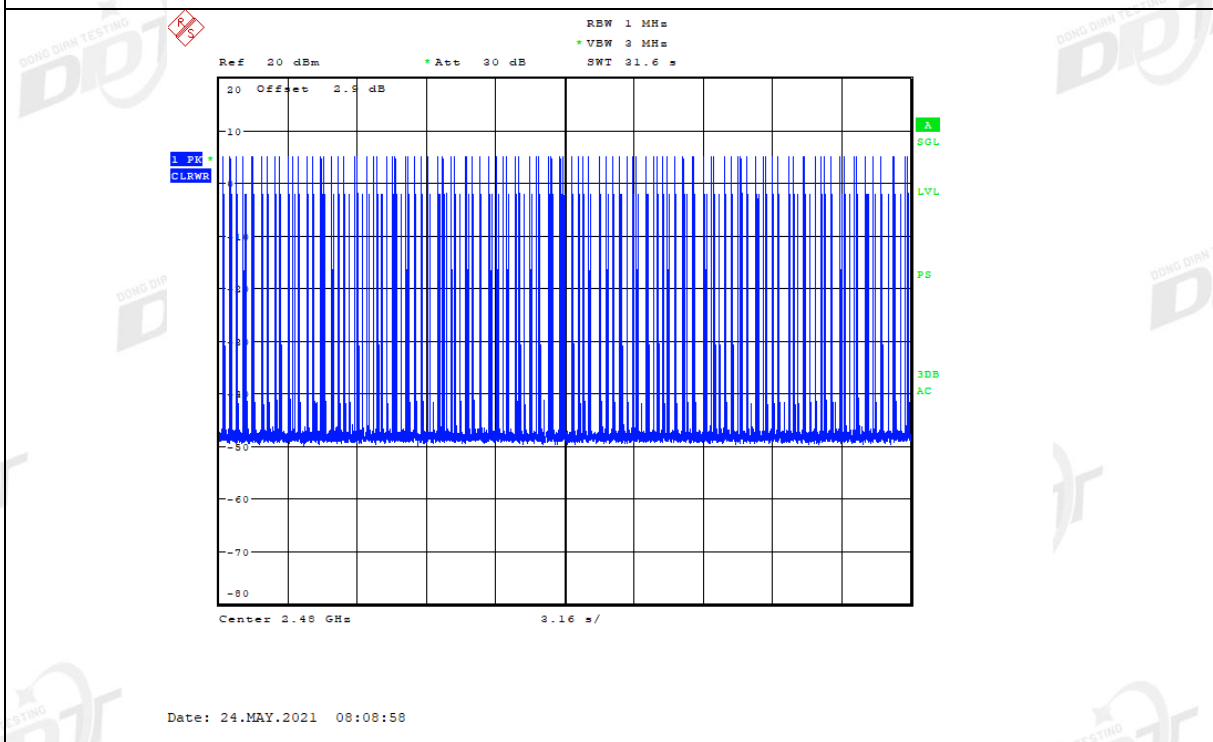
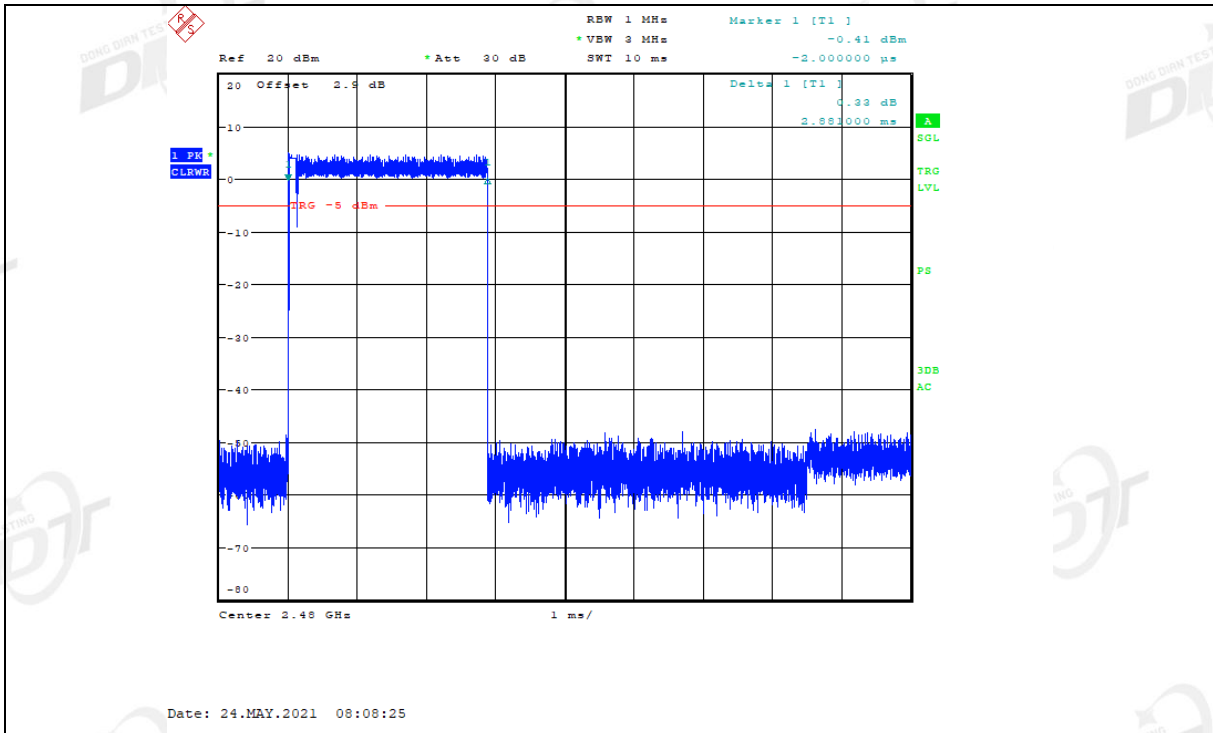

## 9. Band Edge Compliance (Conducted Method)

### 9.1. Block diagram of test setup

Same as section 4.1

### 9.2. Limit

All restriction band should comply with 15.209, other emission should be at least 20dB below the fundamental.

### 9.3. Test result

Mode	Freq. (MHz)	Verdict
GFSK	Hopping off 2402	Pass
	Hopping off 2480	Pass
	Hopping on	Pass
$\pi/4$ -DQPSK	Hopping off 2402	Pass
	Hopping off 2480	Pass
	Hopping on	Pass
8DPSK	Hopping off 2402	Pass
	Hopping off 2480	Pass
	Hopping on	Pass

### 9.4. Original test data

Left side:

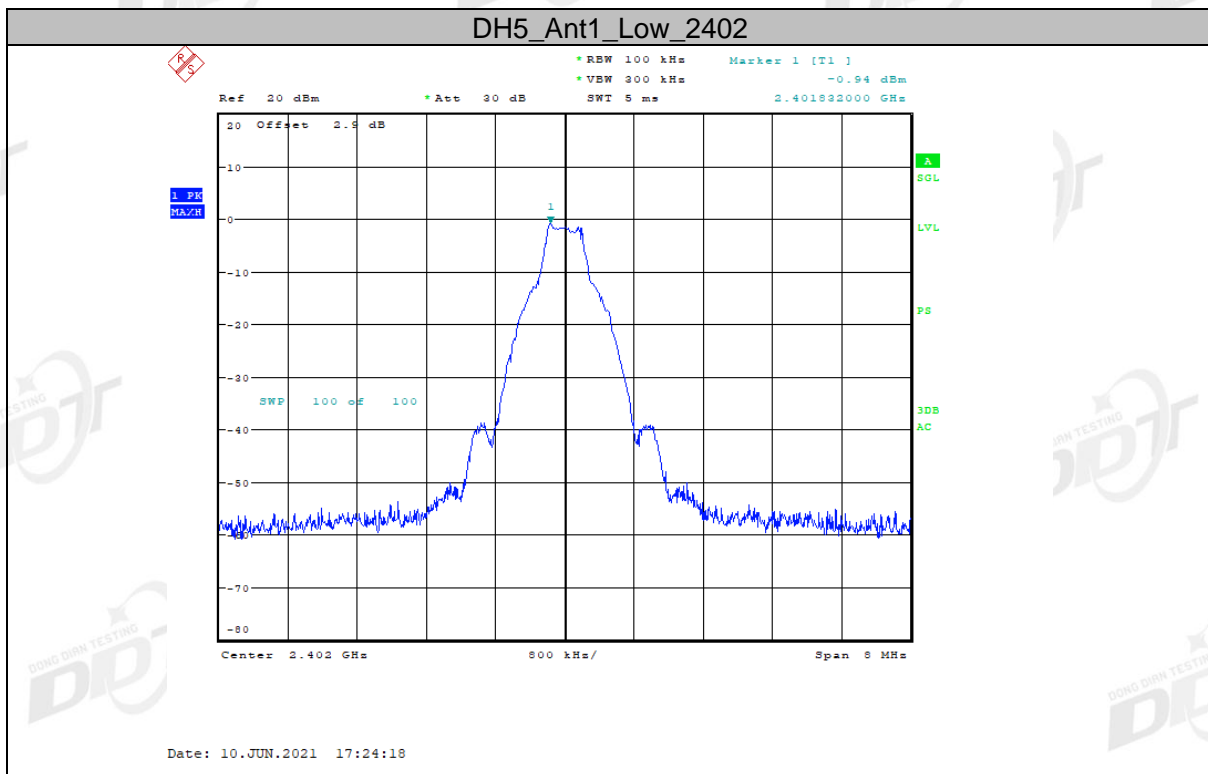

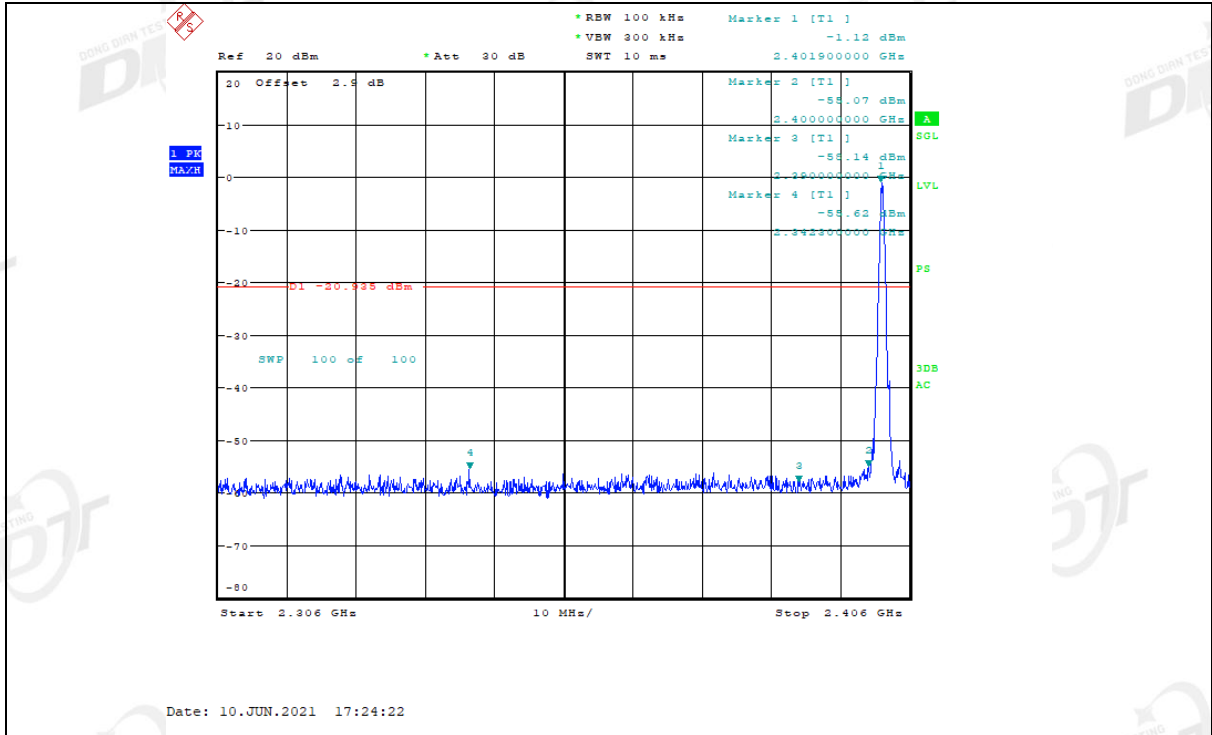

DH5\_Ant1\_High\_2480

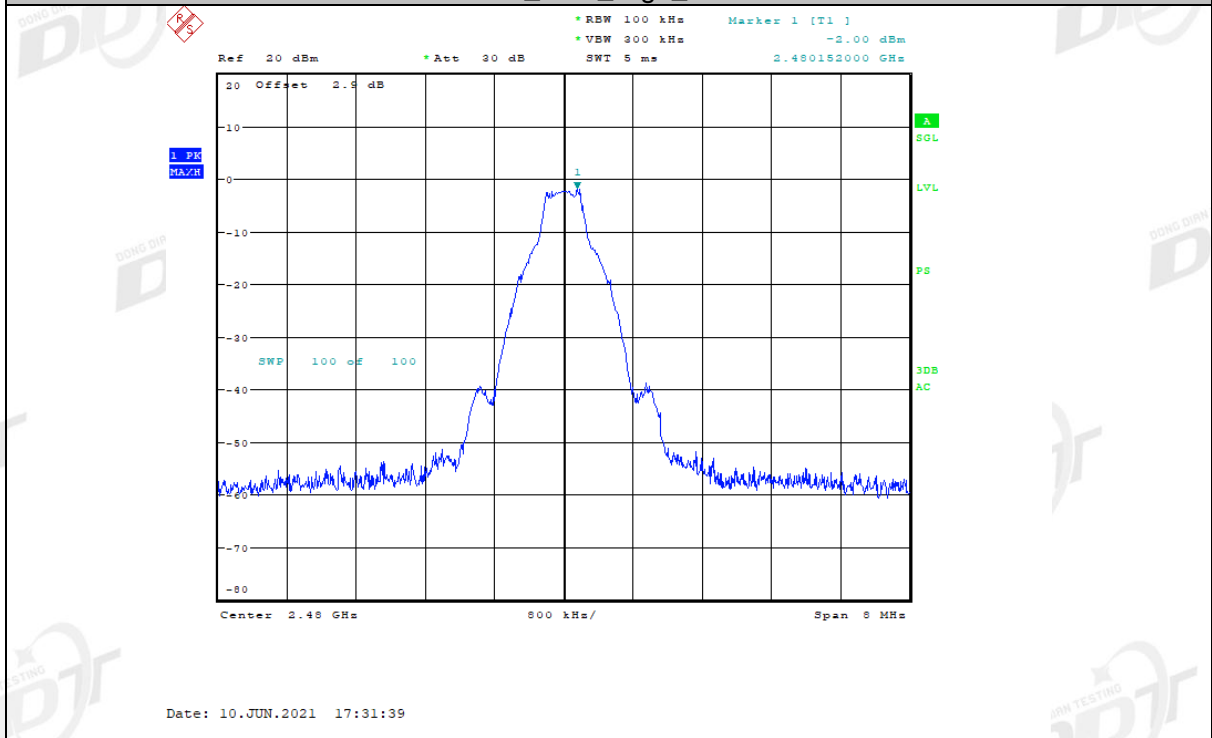

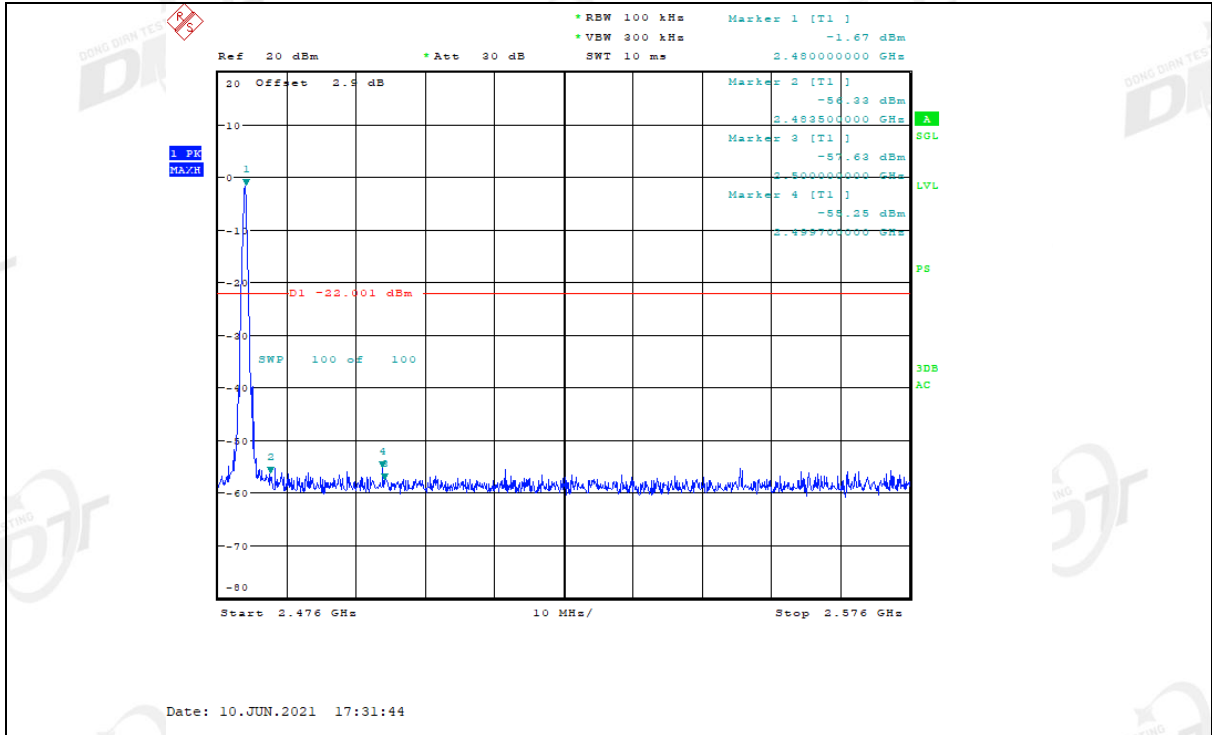

DH5\_Ant1\_Low\_Hop\_2402

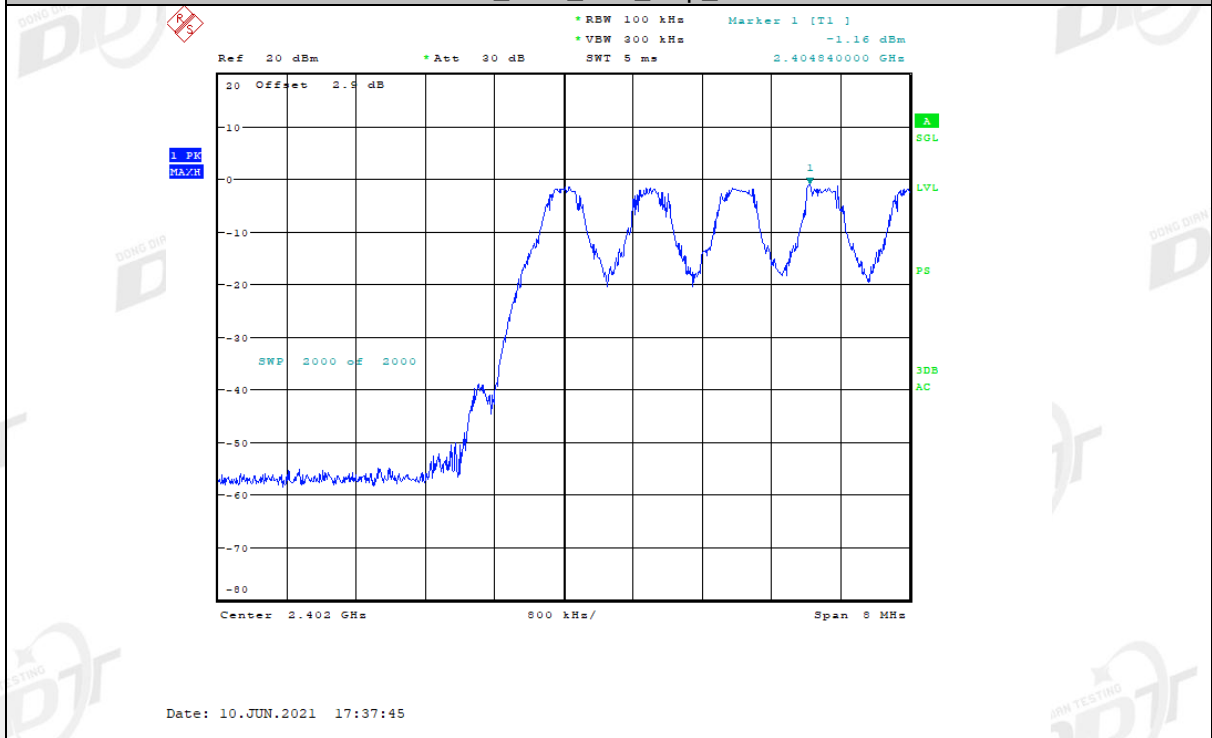



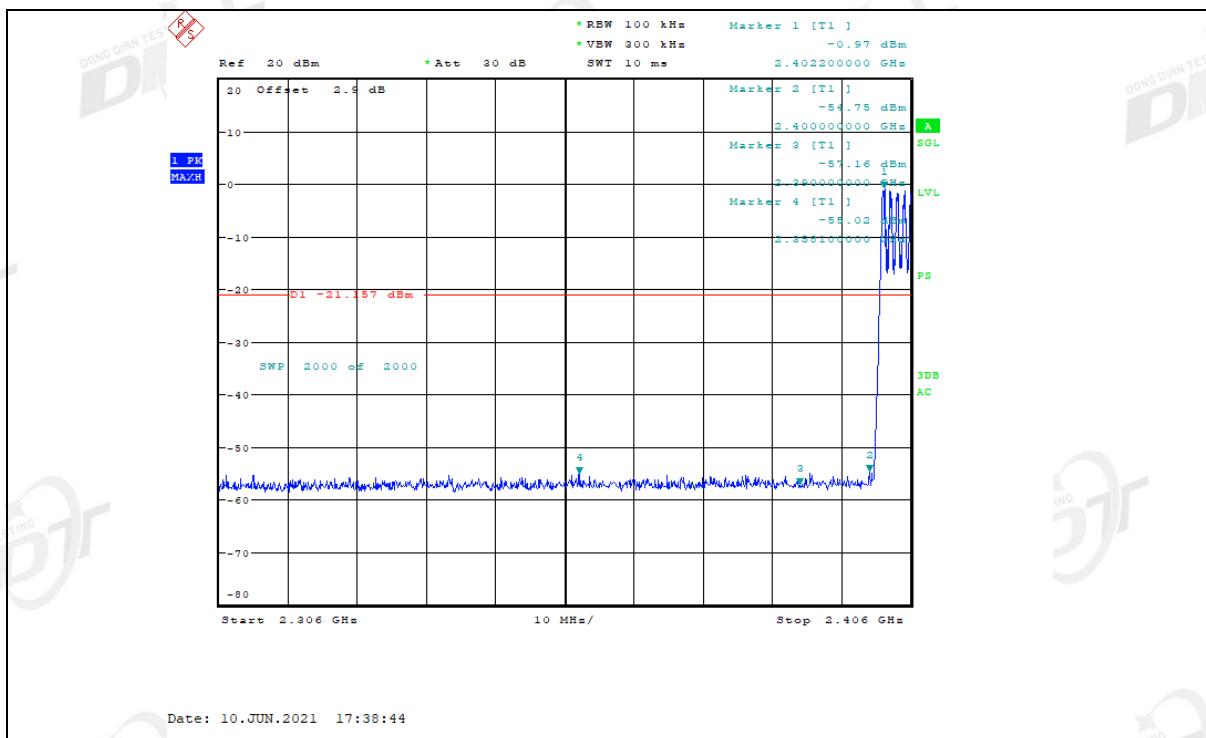

DH5\_Ant1\_High\_Hop\_2480

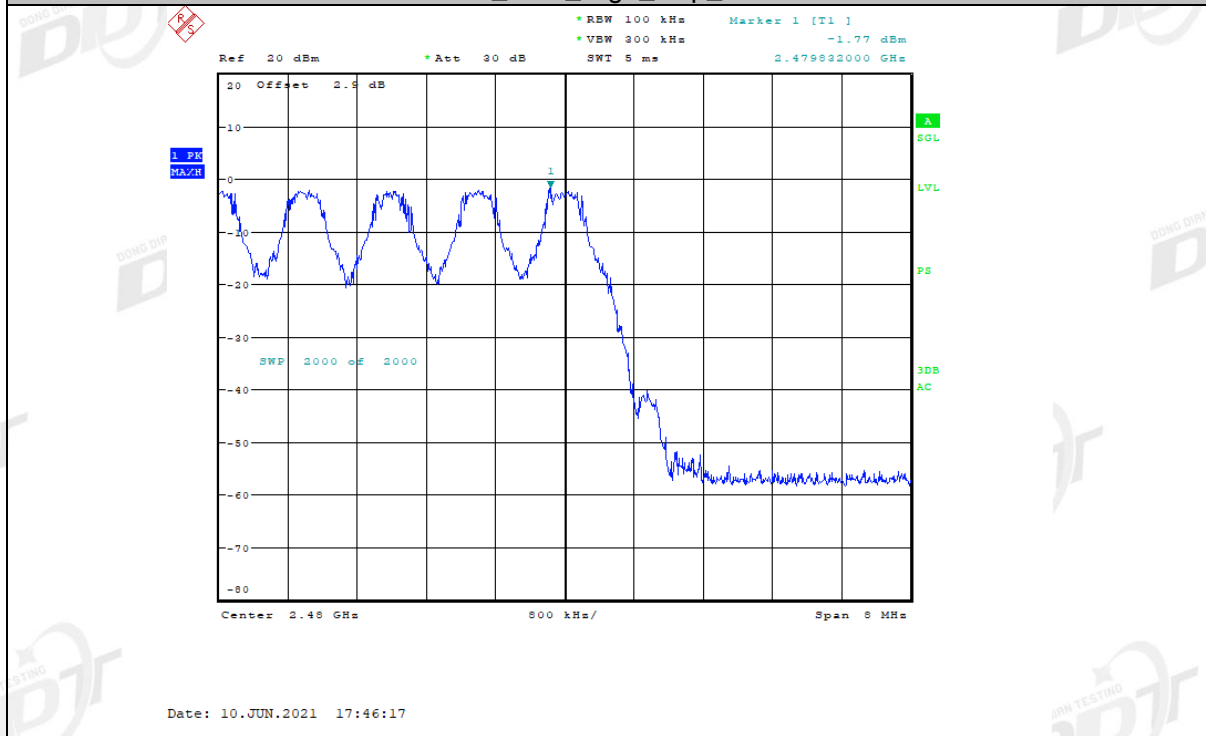

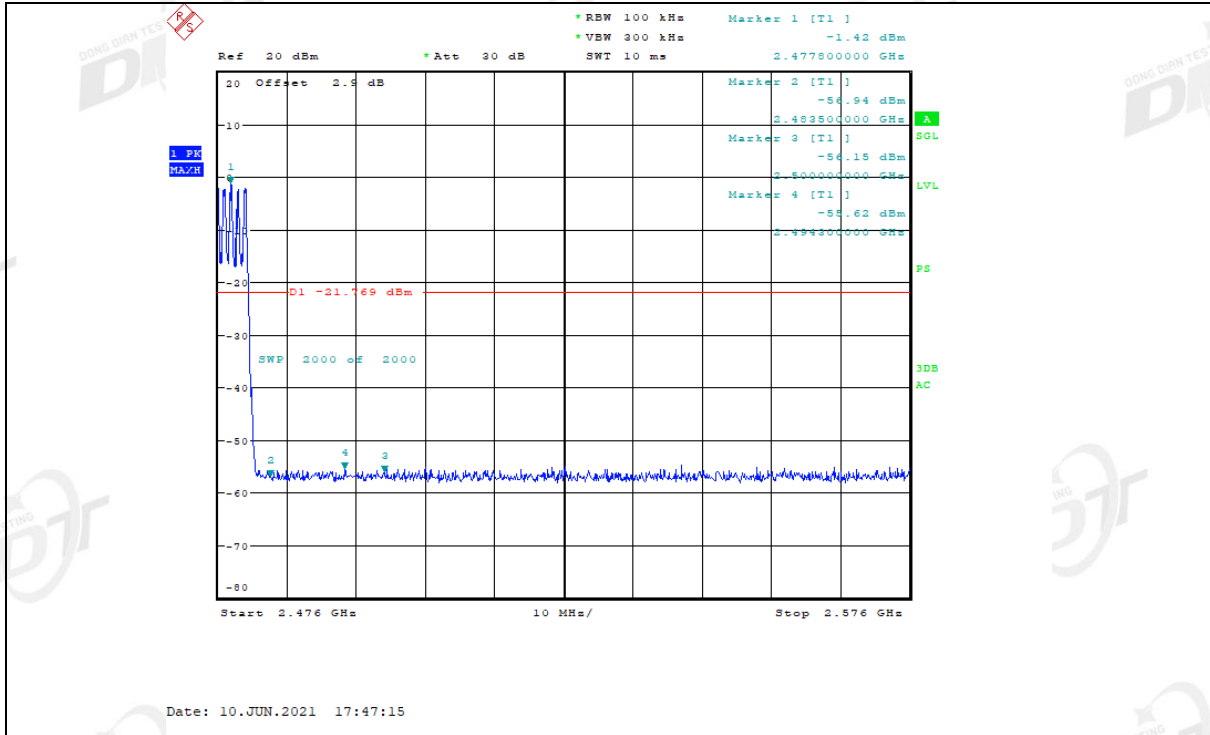

2DH5\_Ant1\_Low\_2402

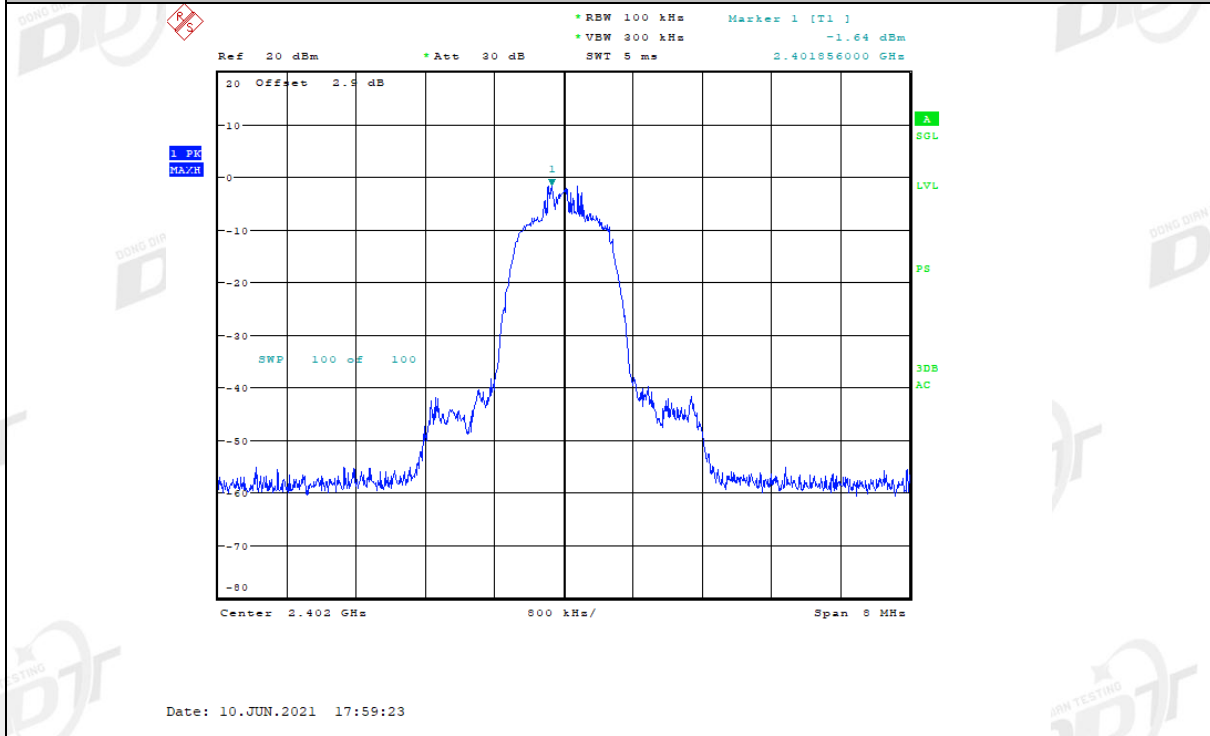

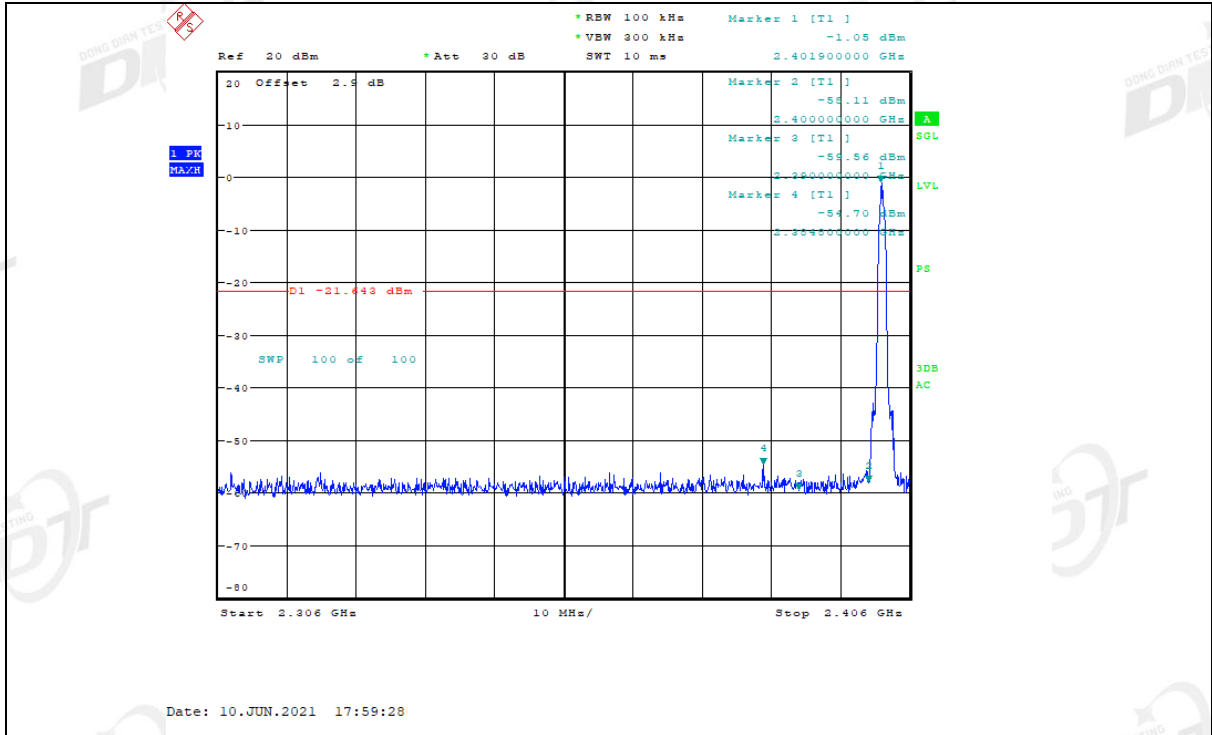

2DH5\_Ant1\_High\_2480

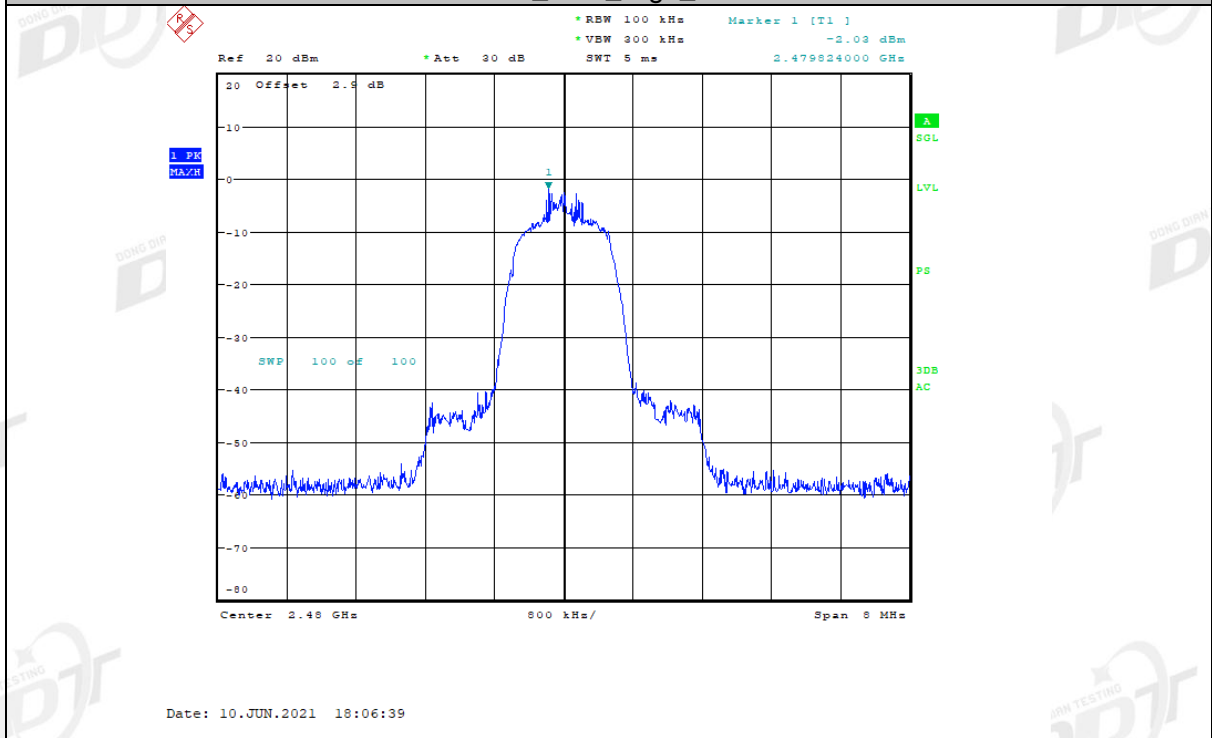

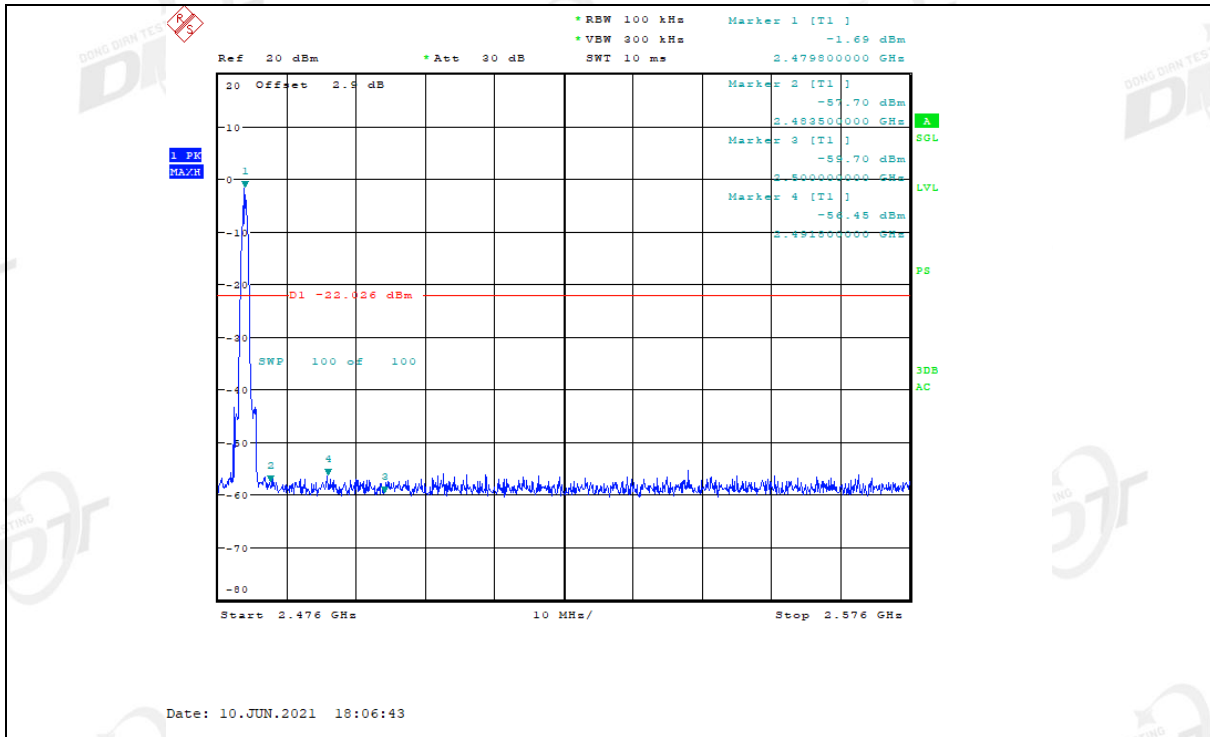

2DH5\_Ant1\_Low\_Hop\_2402

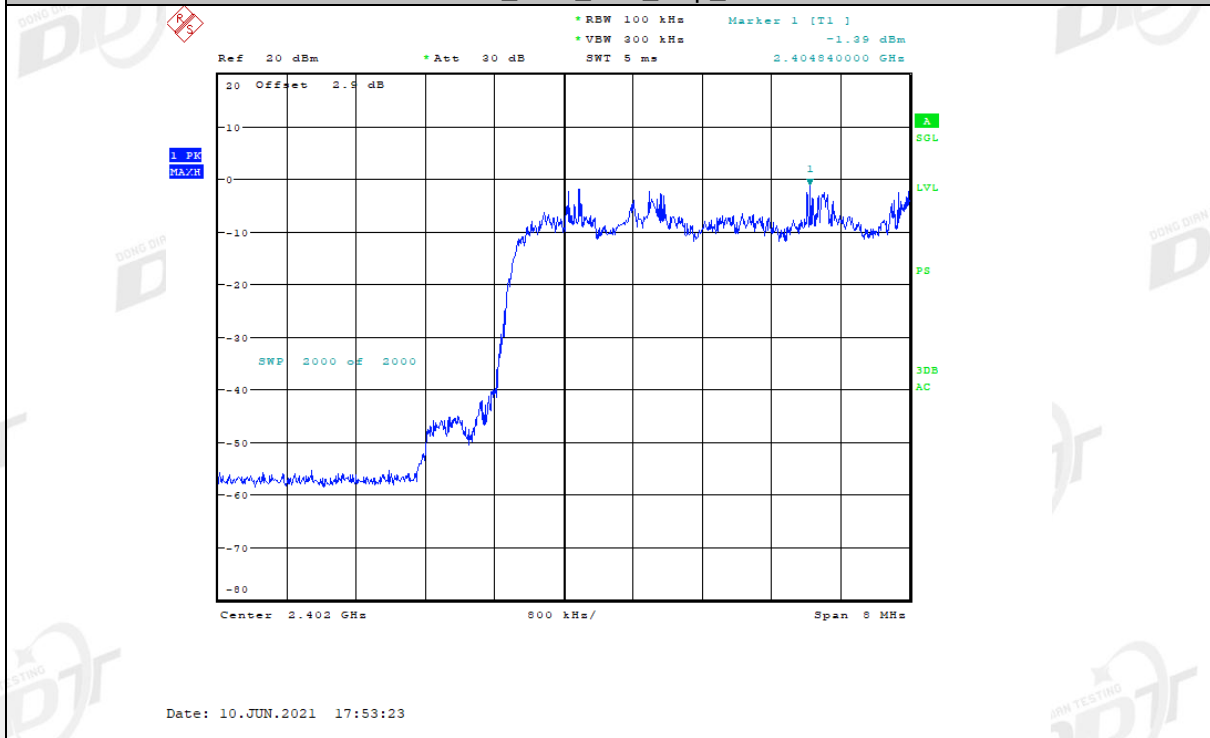

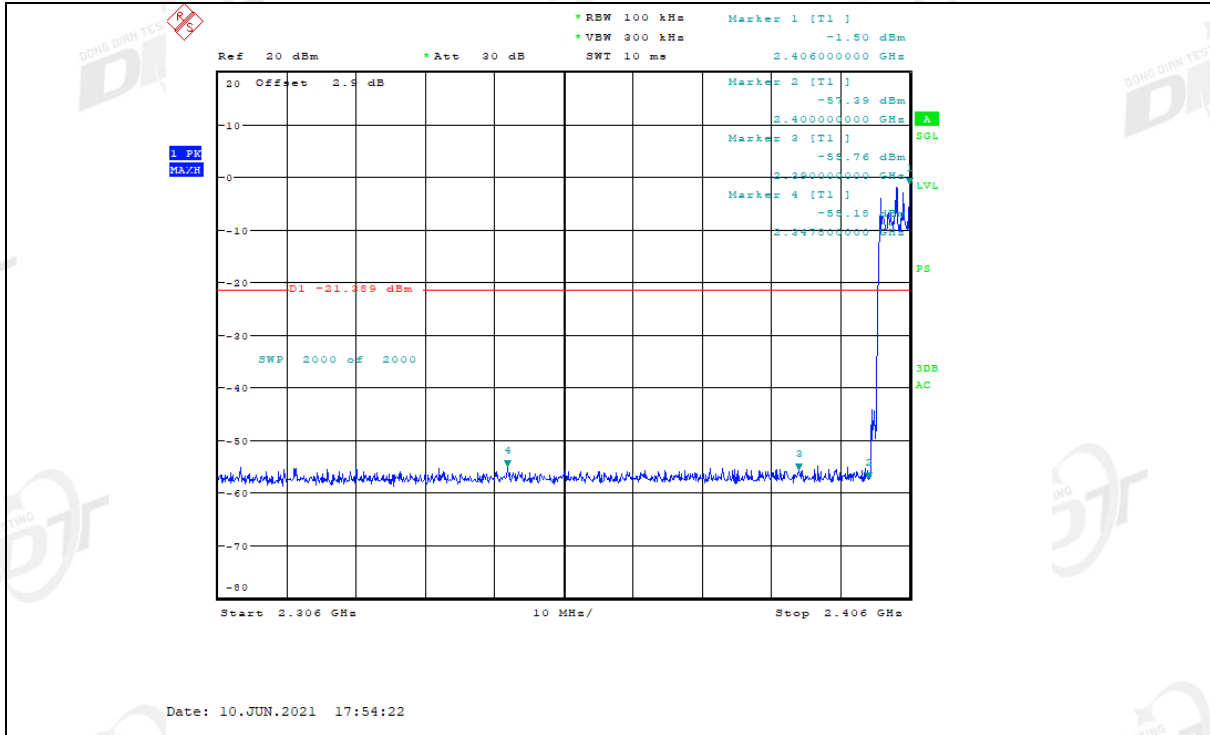

2DH5\_Ant1\_High\_Hop\_2480

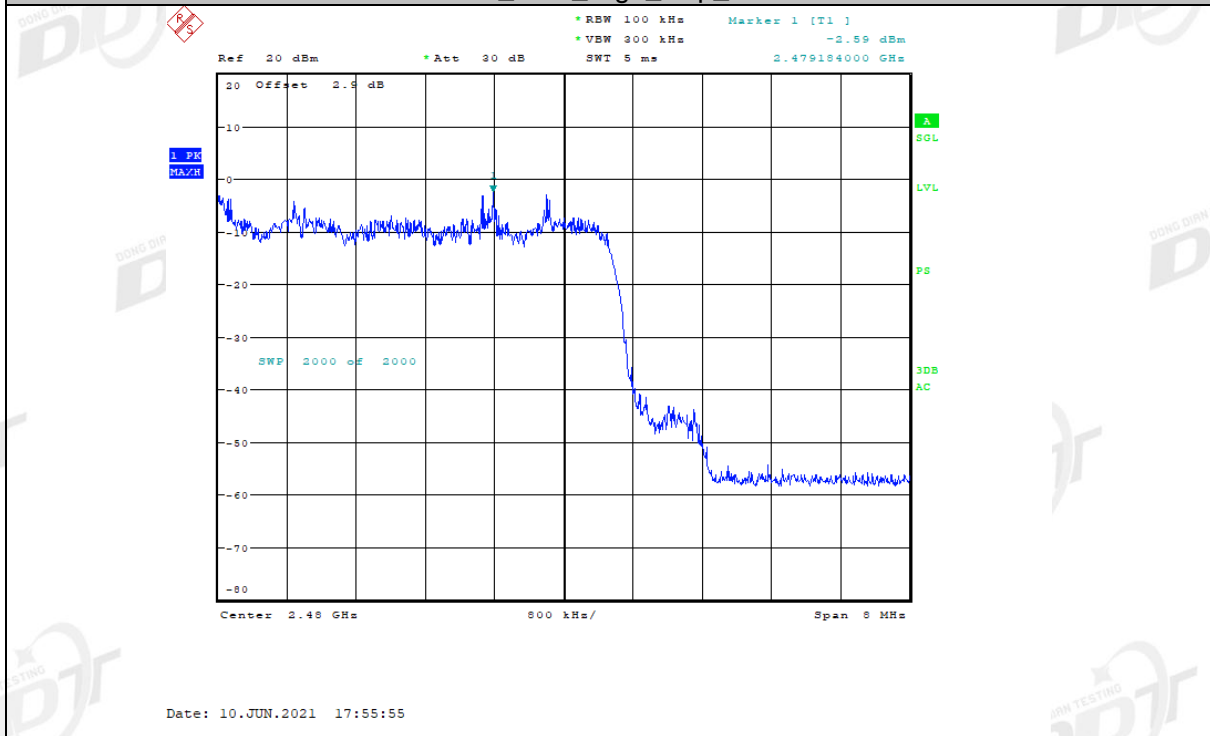

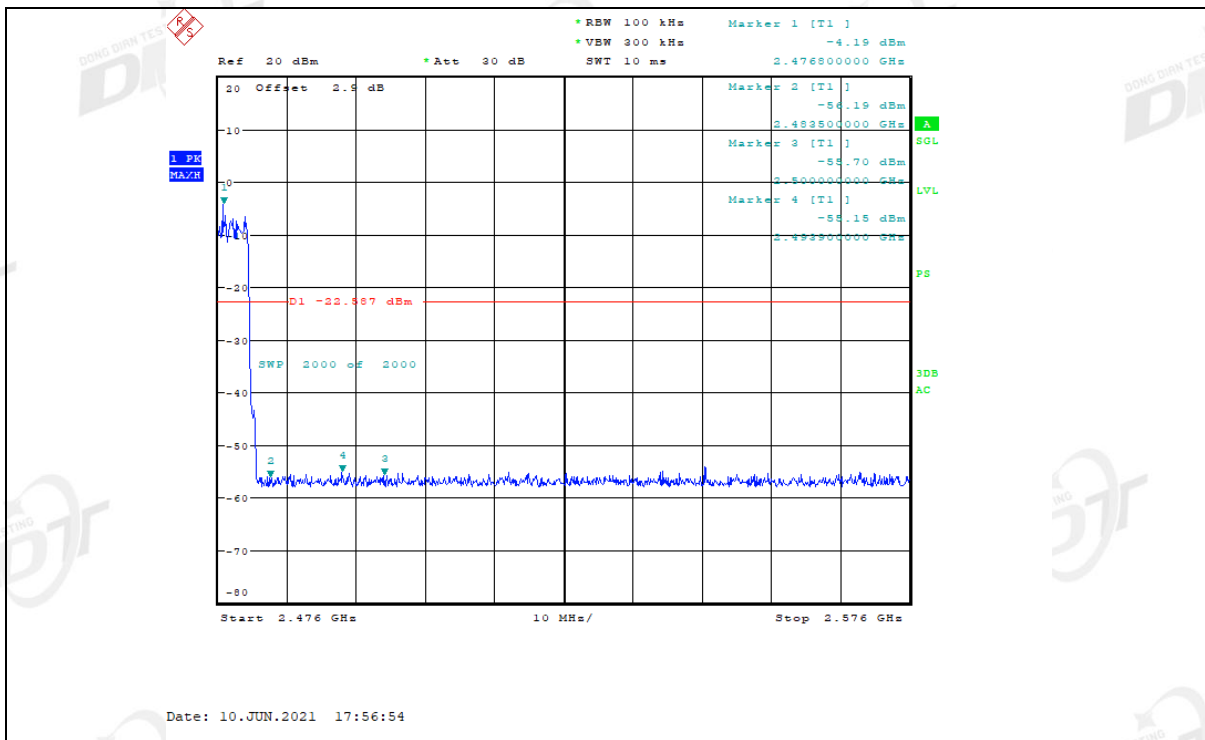

3DH5\_Ant1\_Low\_2402

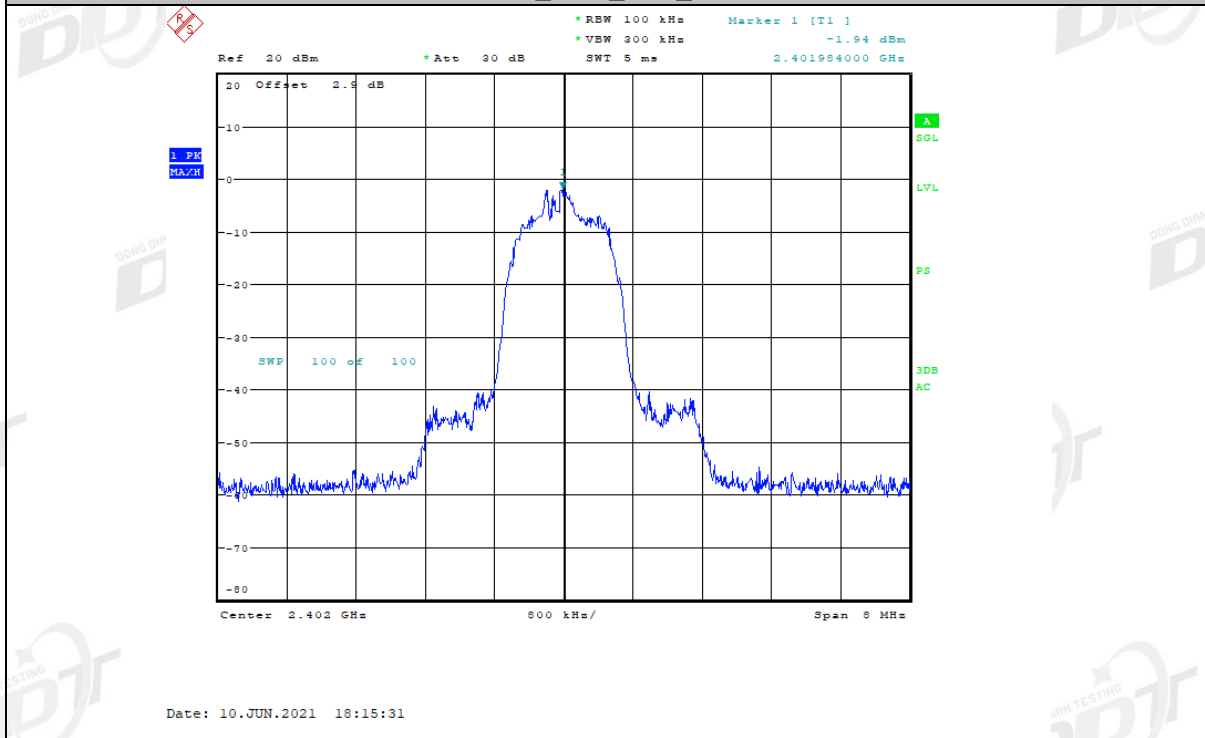

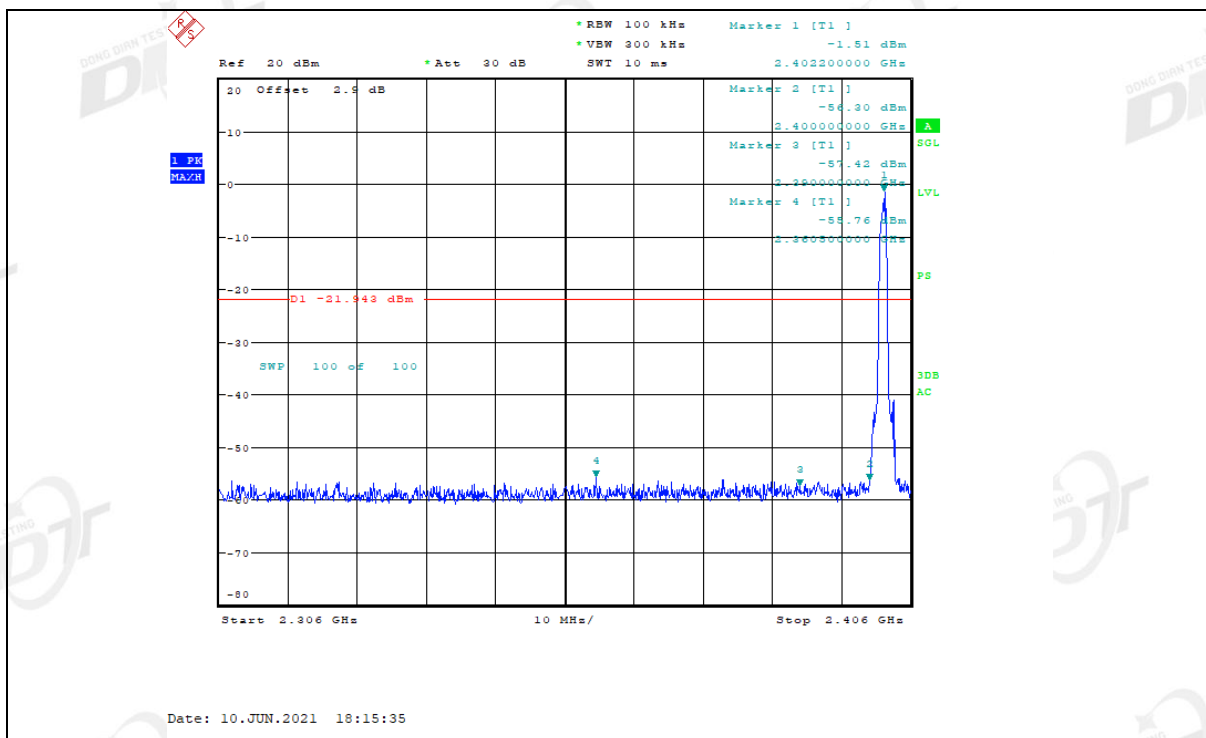

### 3DH5\_Ant1\_High\_2480

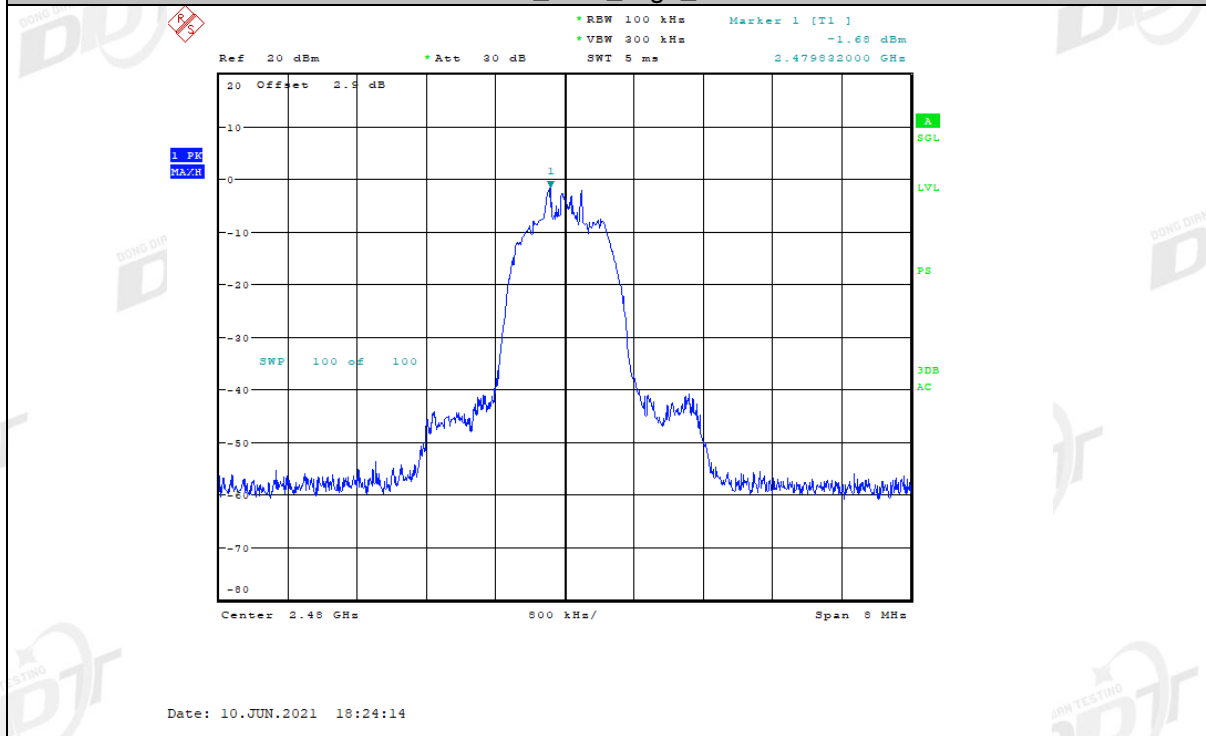

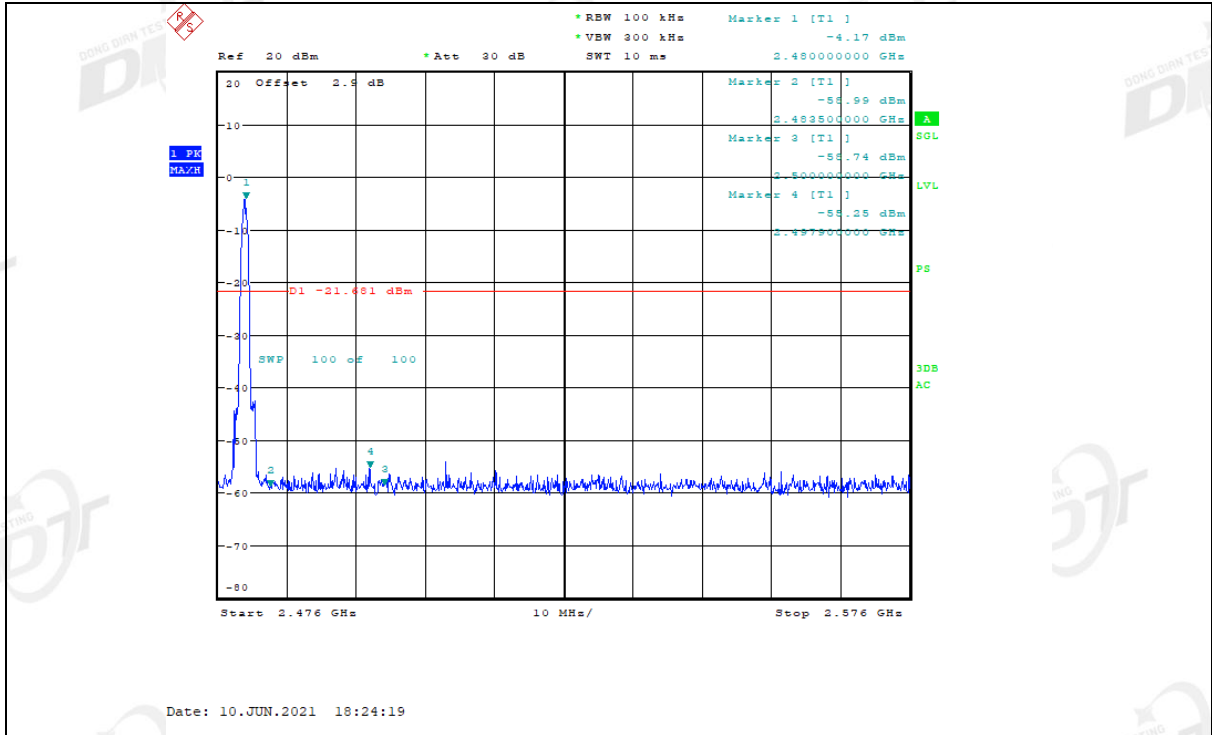

3DH5\_Ant1\_Low\_Hop\_2402





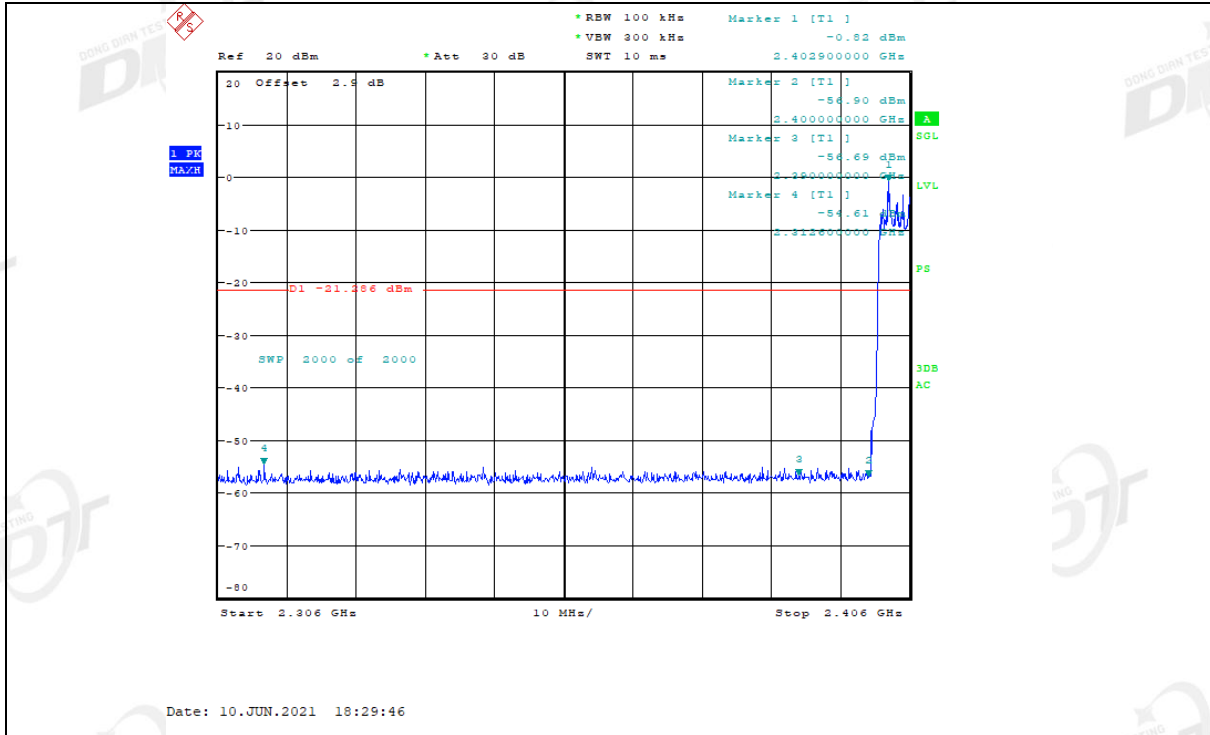

3DH5\_Ant1\_High\_Hop\_2480

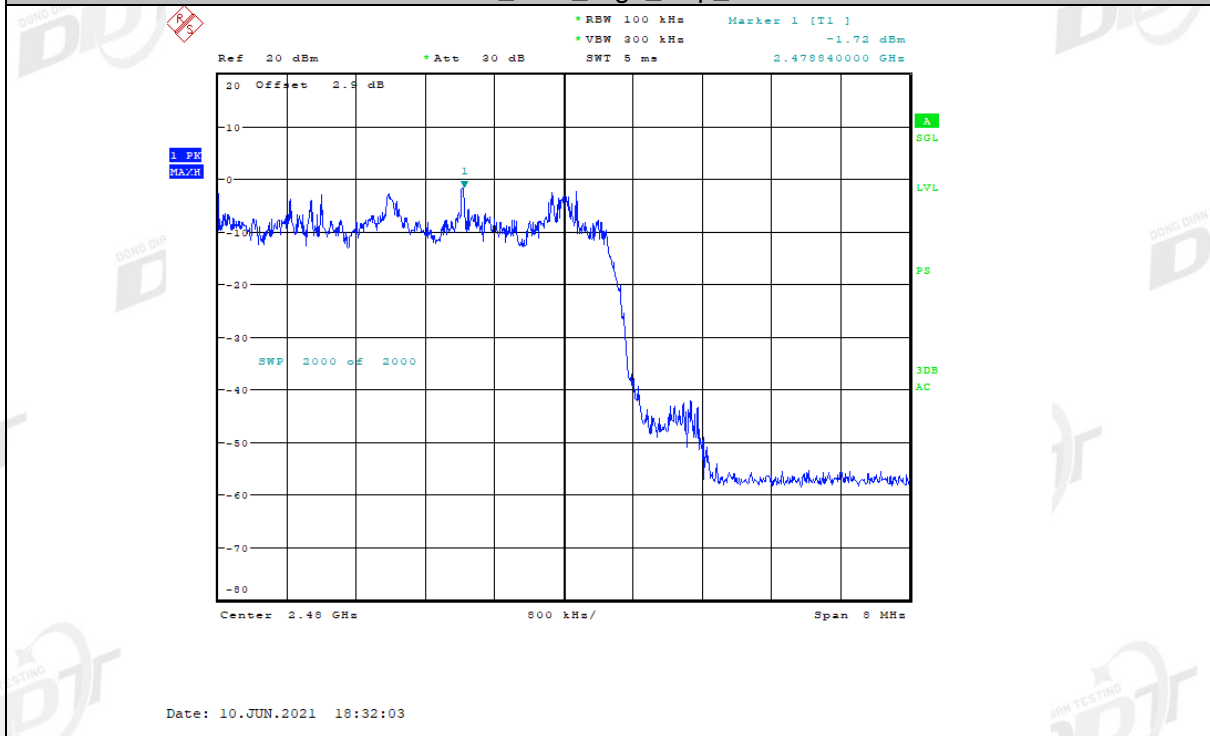

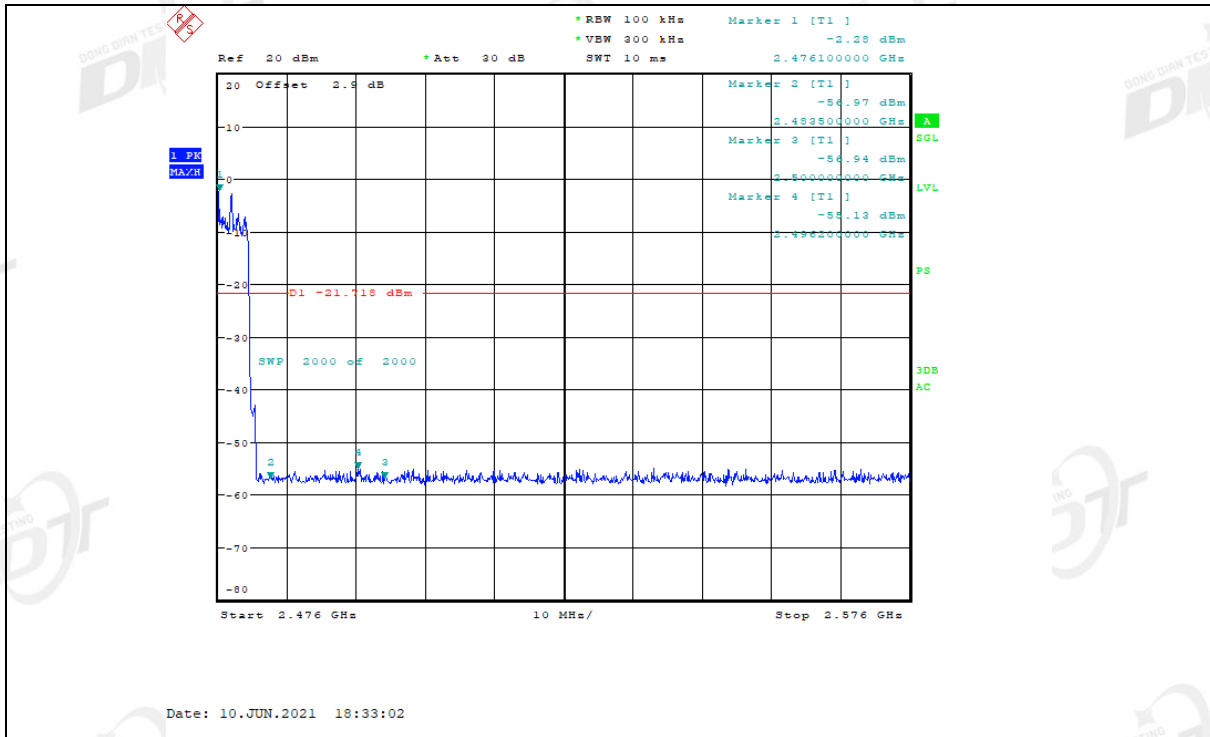

Right side:

DH5\_Ant1\_Low\_2402

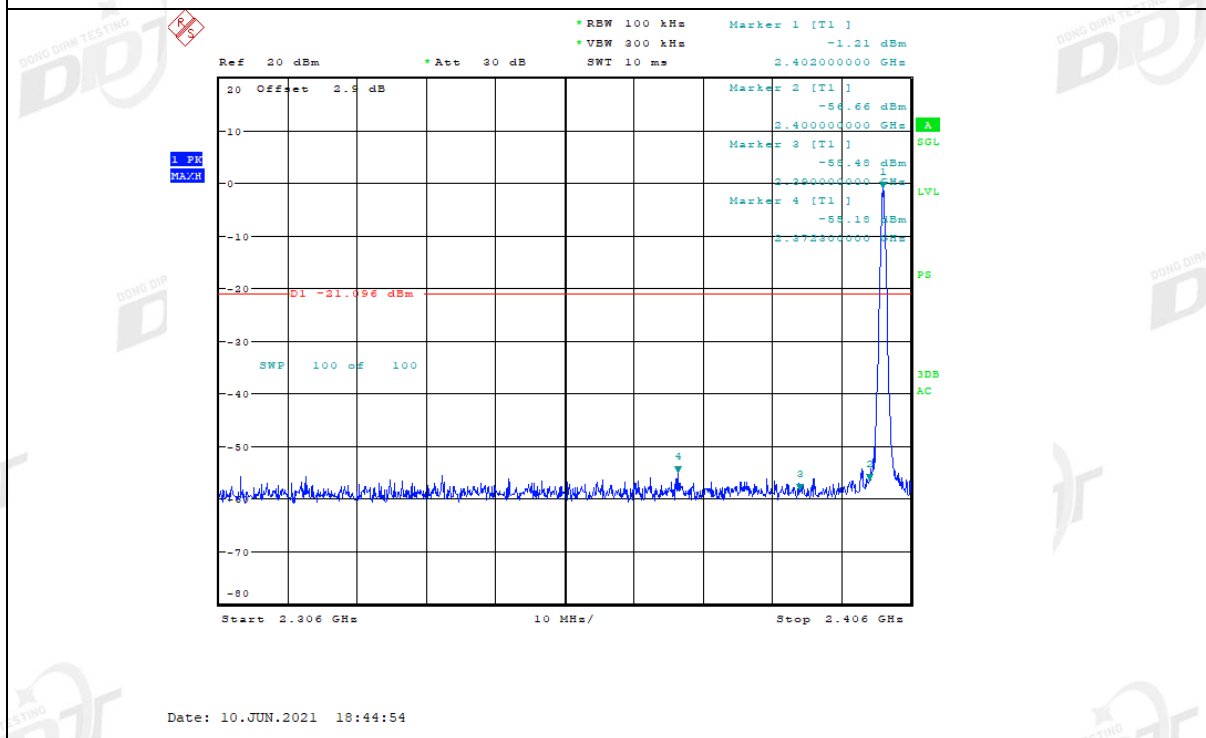
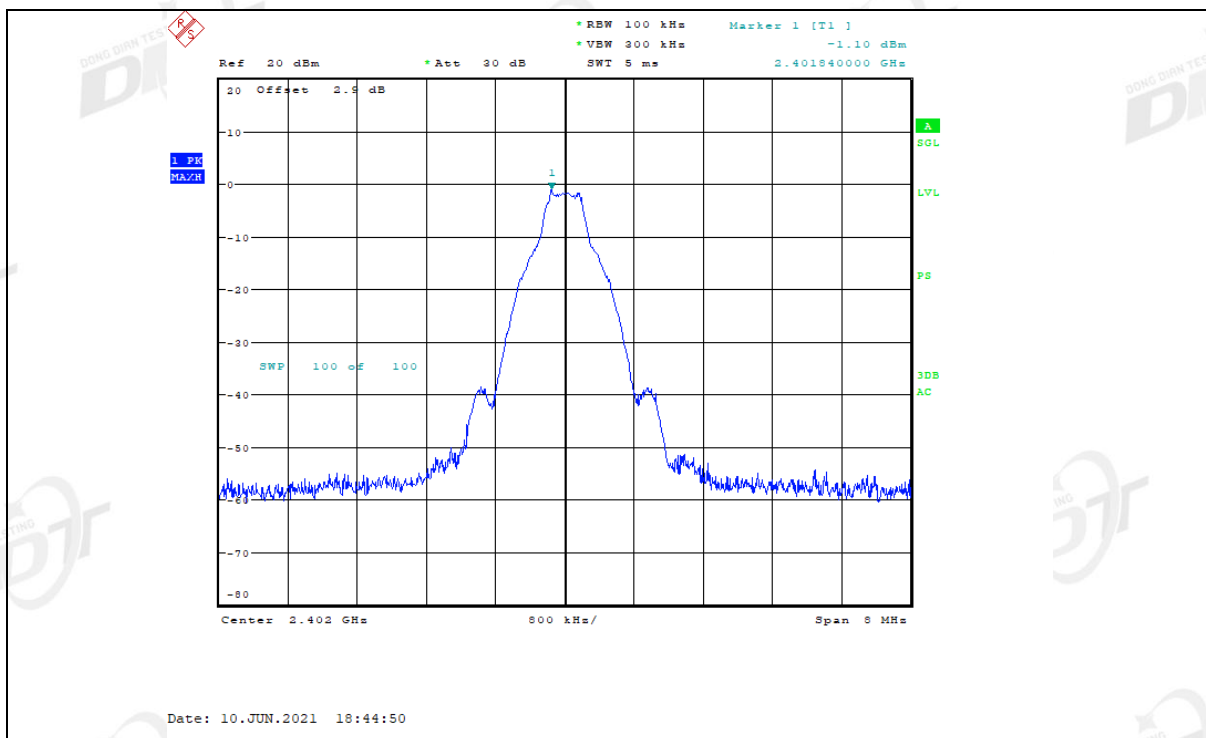

DH5\_Ant1\_High\_2480

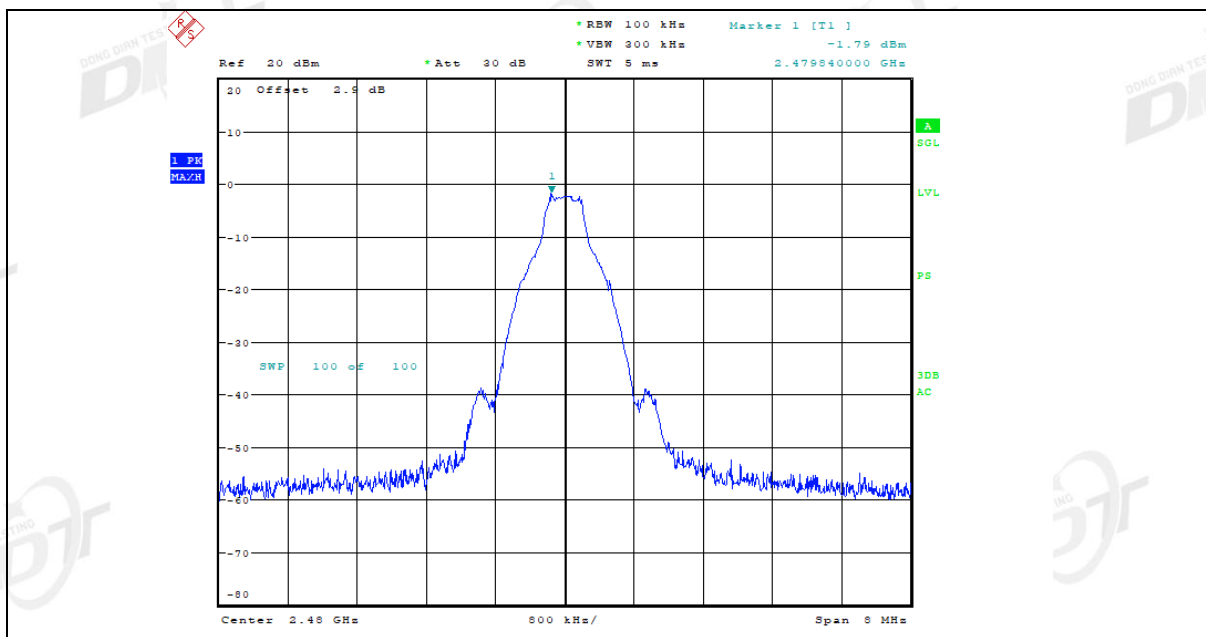

Date: 10.JUN.2021 18:51:22

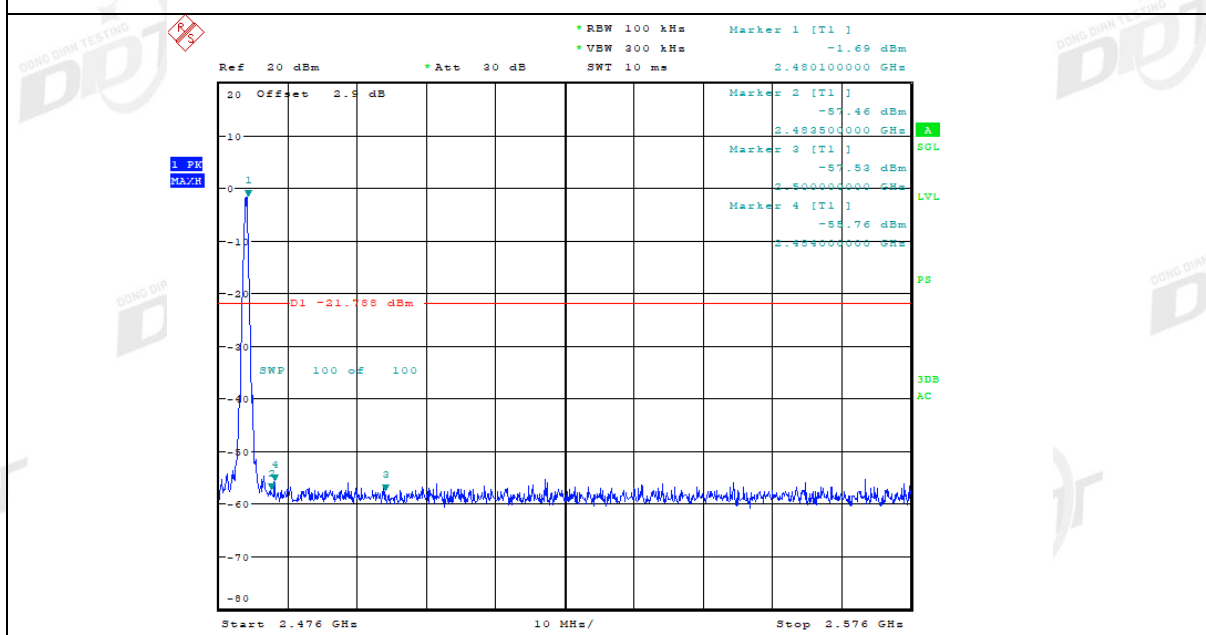

Date: 10.JUN.2021 18:51:26

DH5\_Ant1\_Low\_Hop\_2402

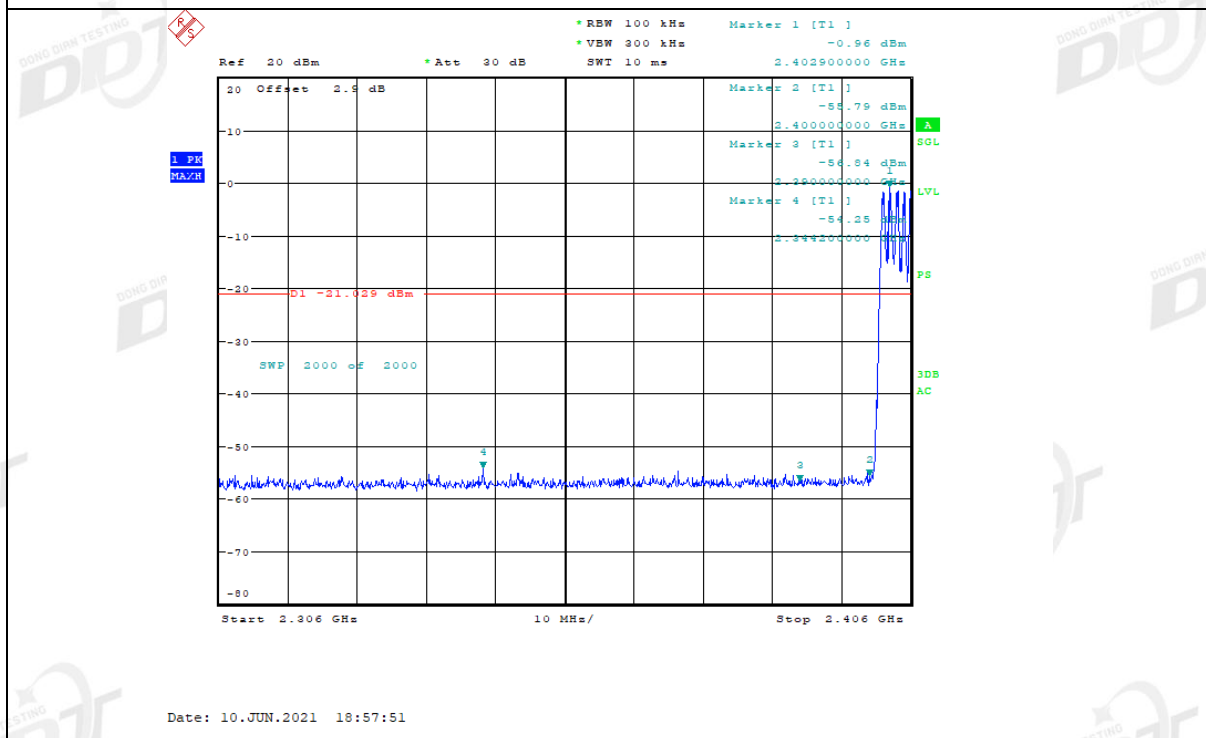
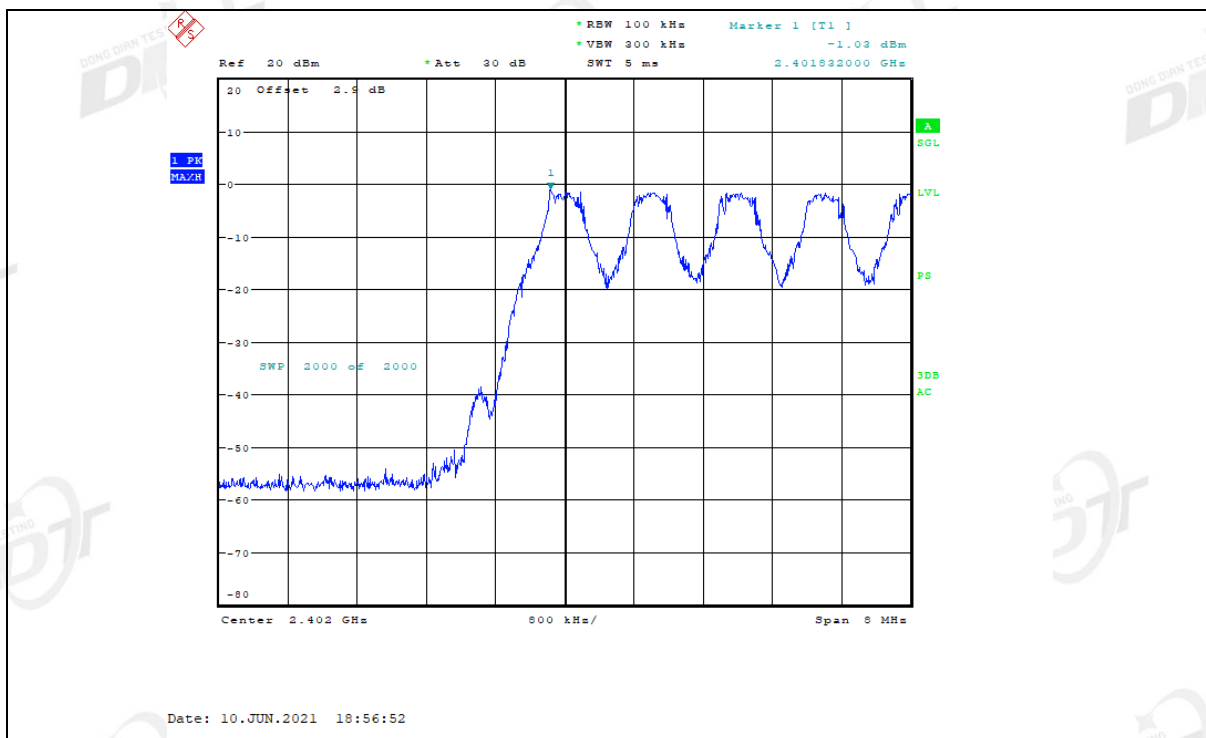

DH5\_Ant1\_High\_Hop\_2480

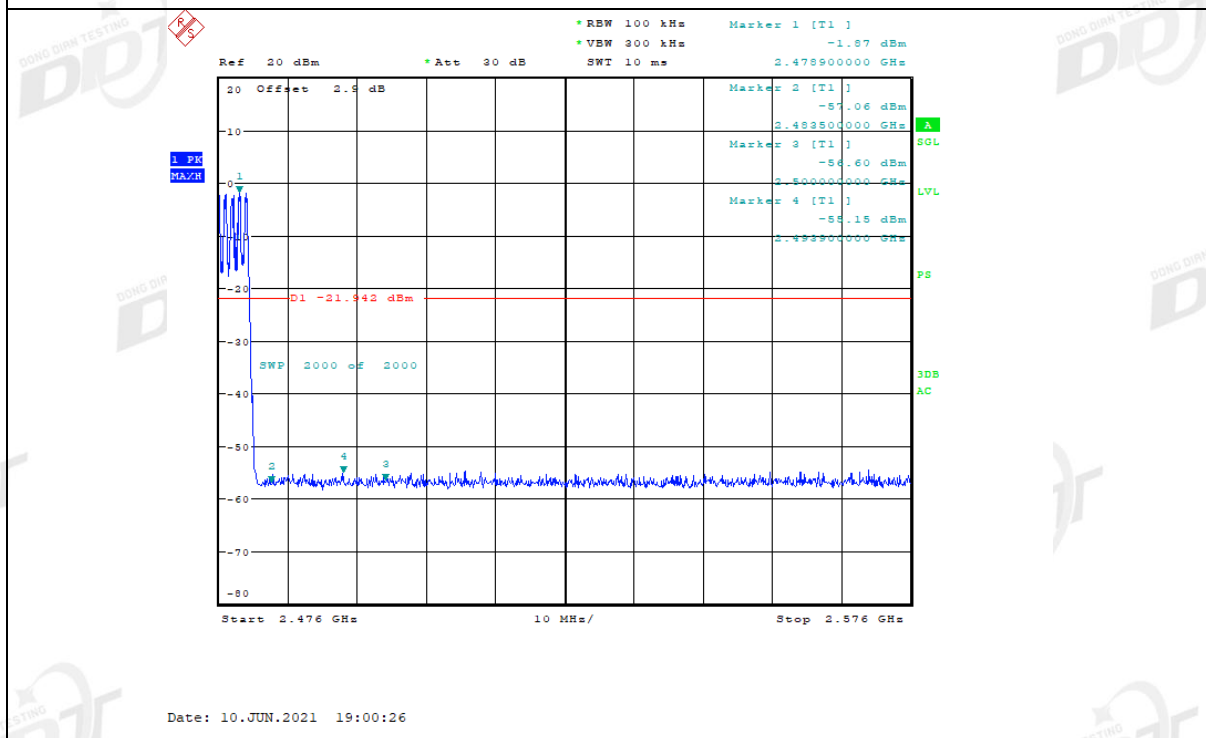
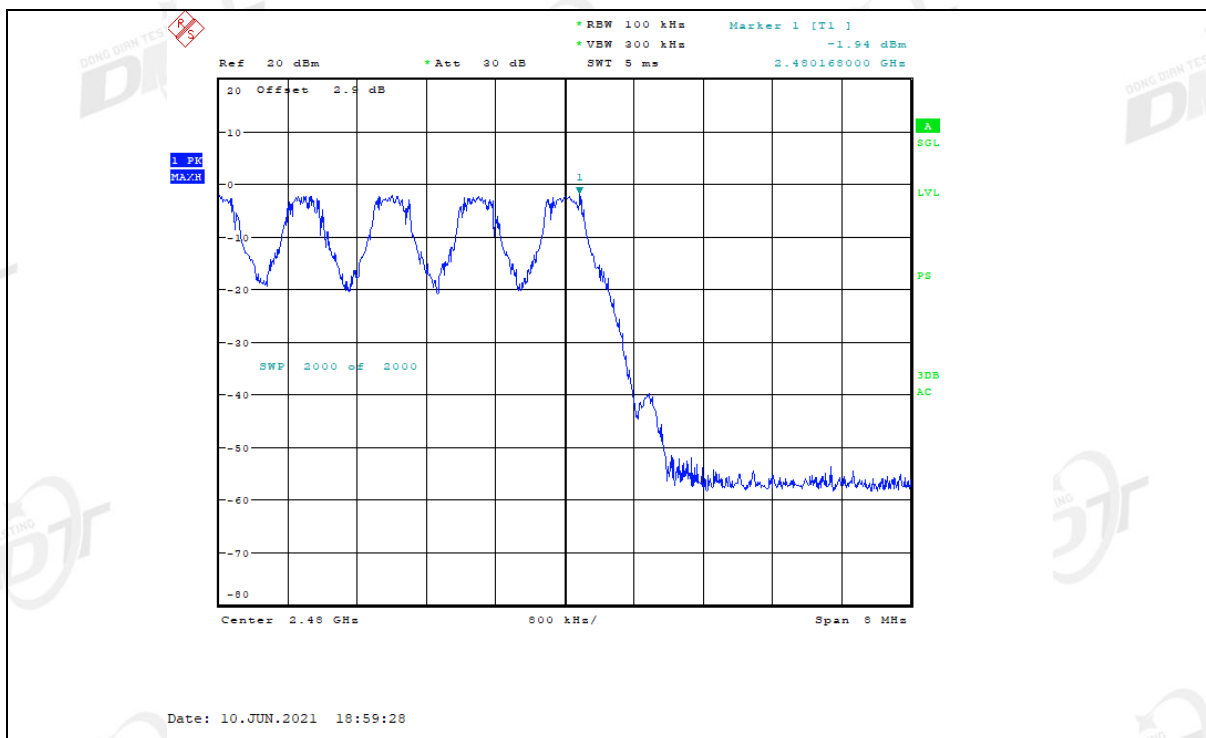

2DH5\_Ant1\_Low\_2402

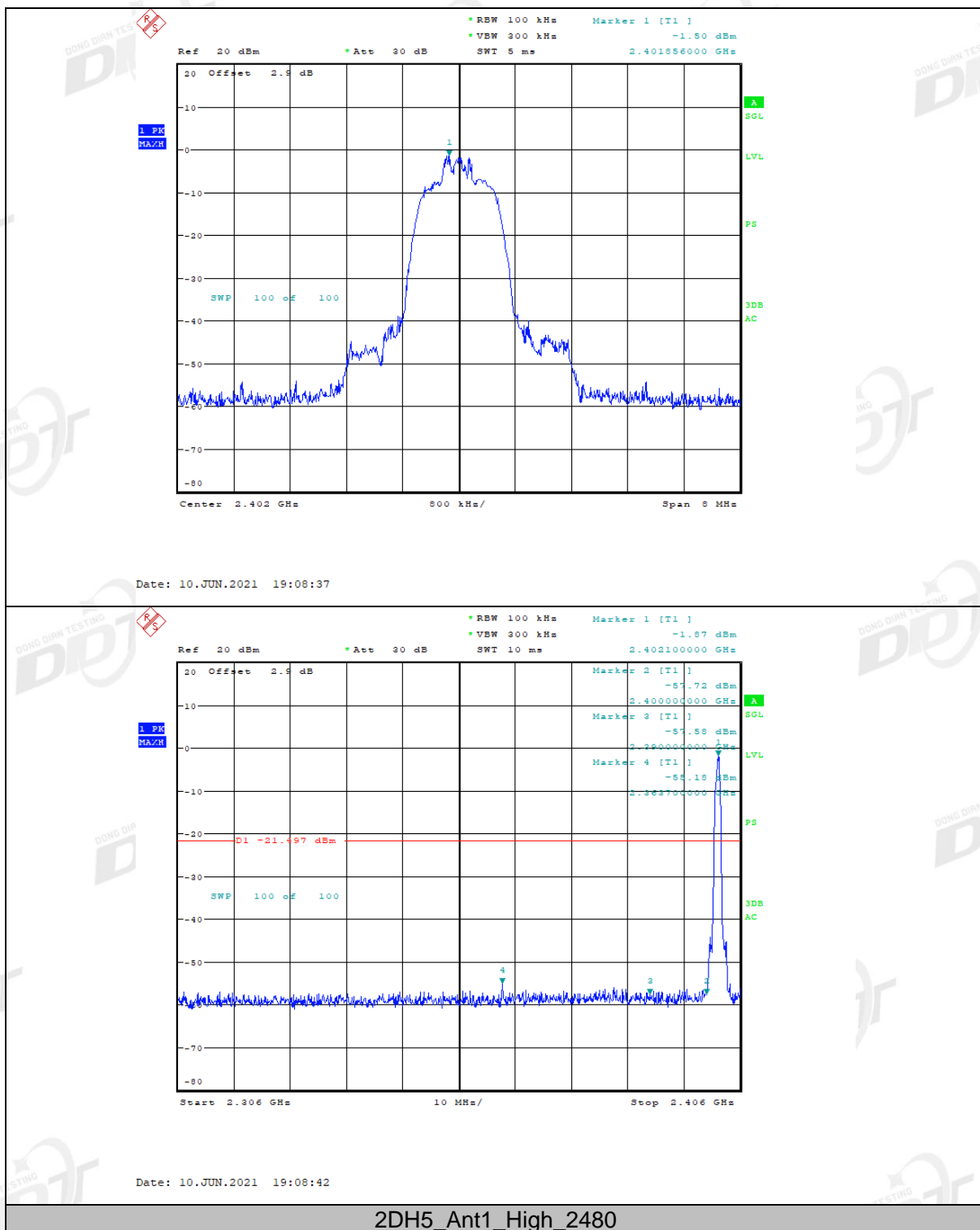

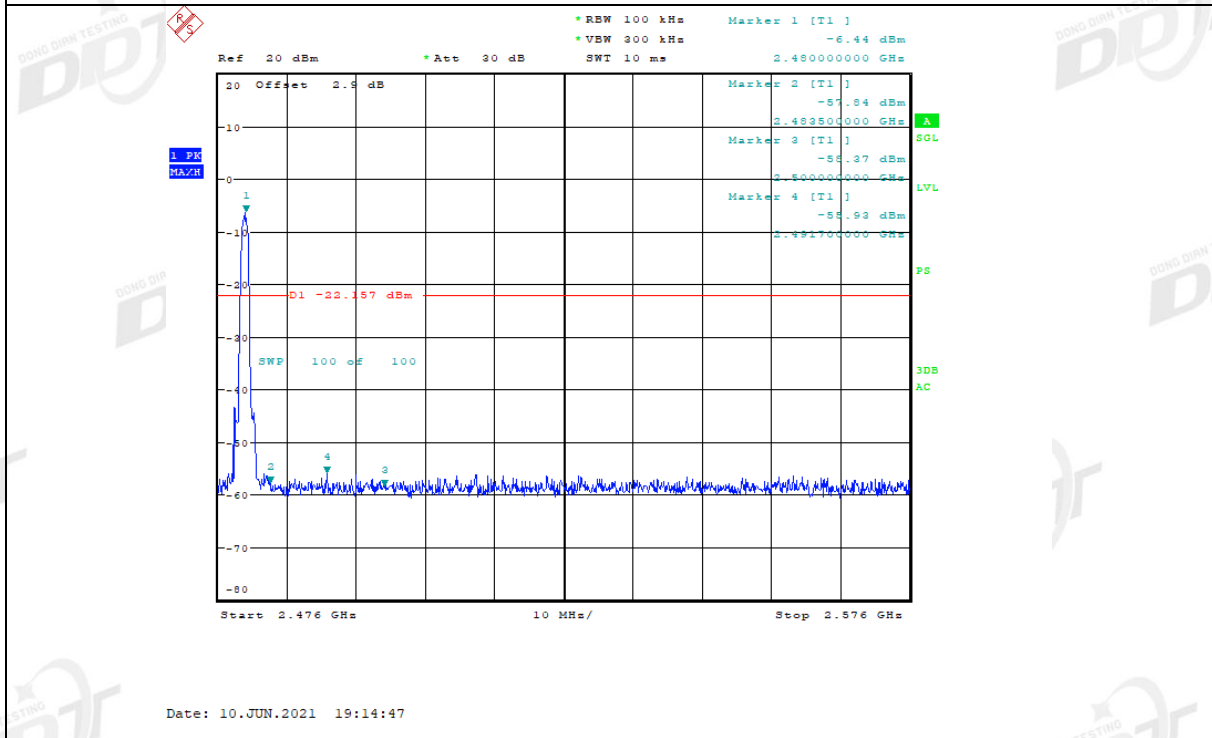
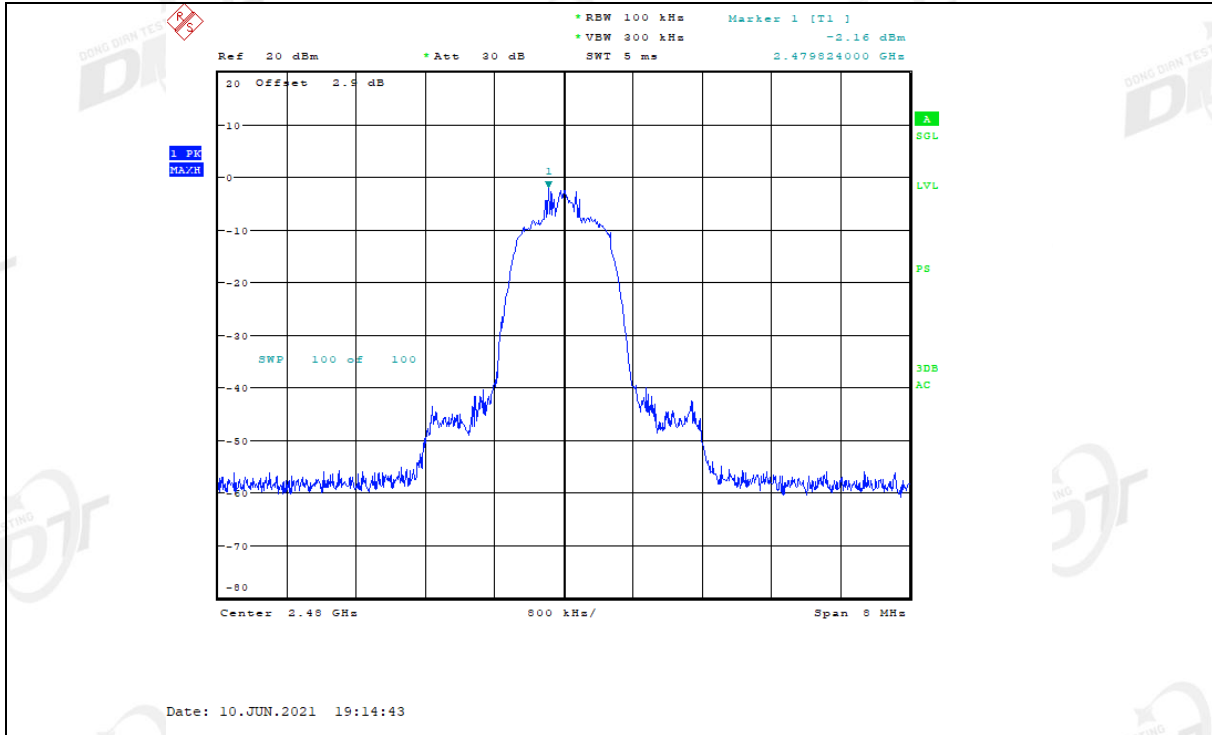

2DH5\_Ant1\_Low\_Hop\_2402



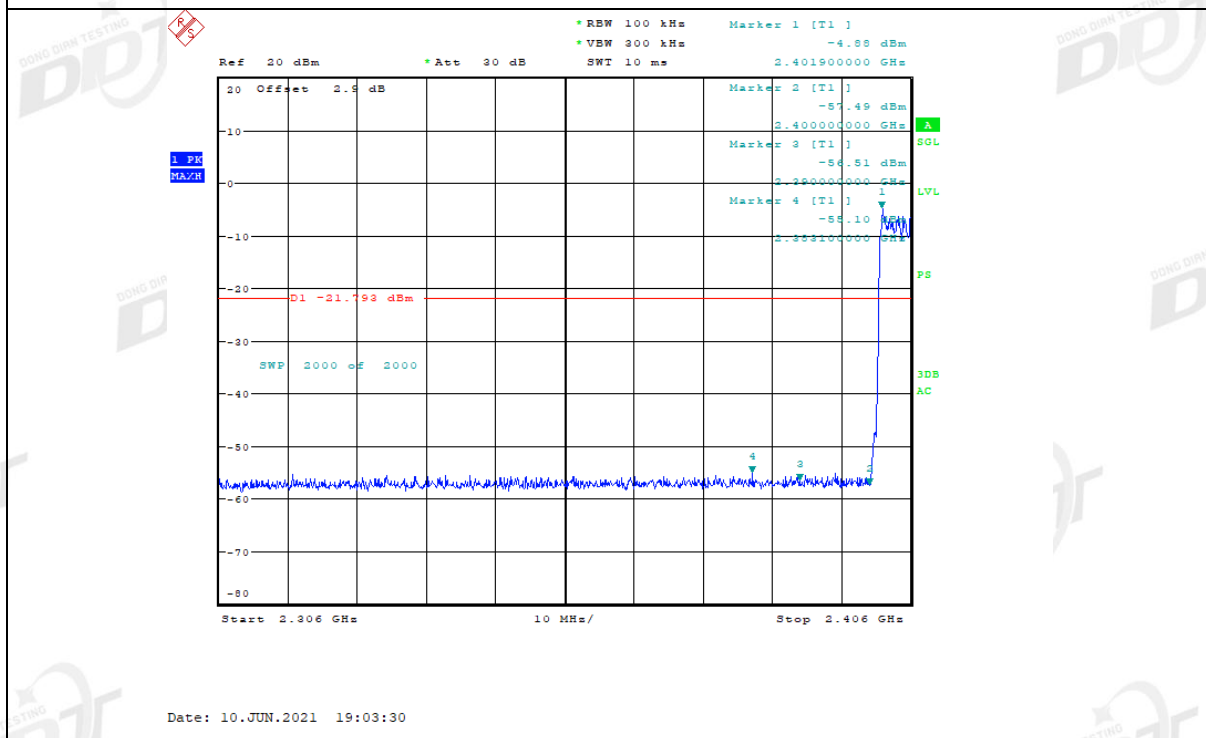
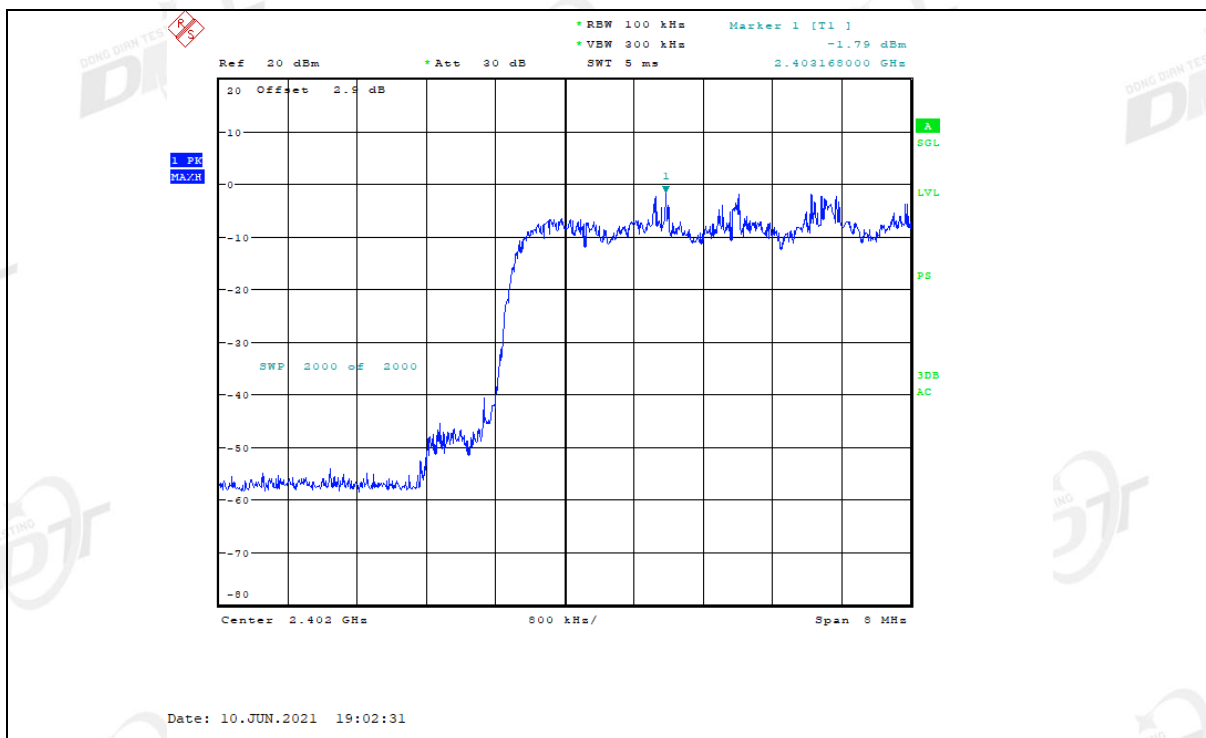

2DH5\_Ant1\_High\_Hop\_2480

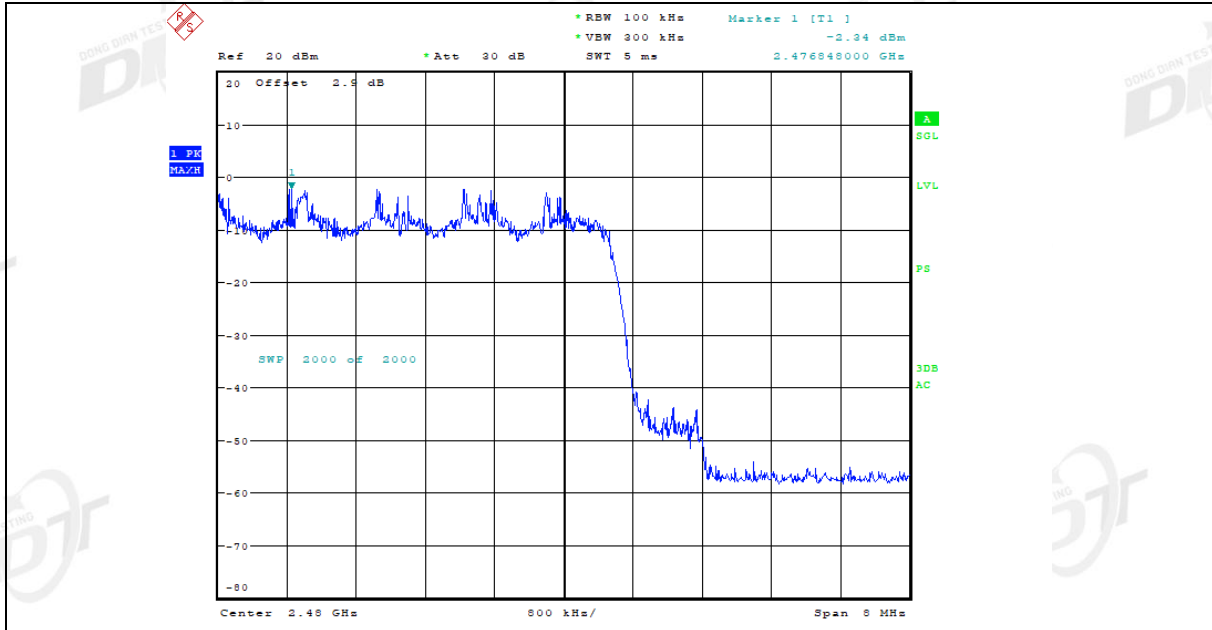

Date: 10.JUN.2021 19:05:04

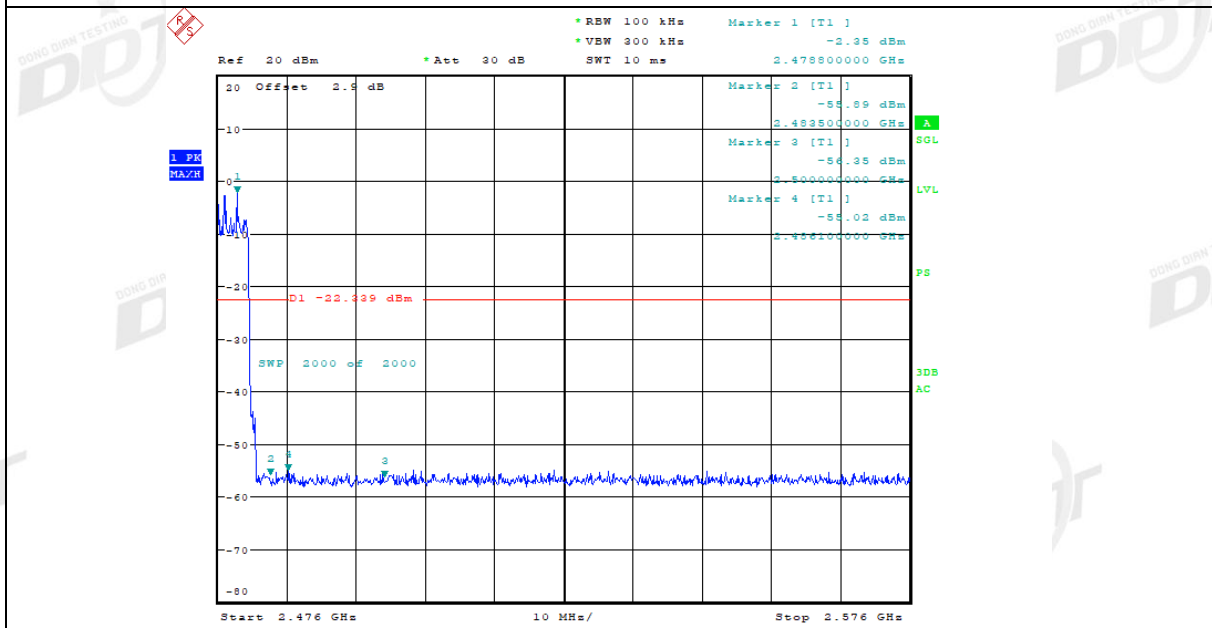

Date: 10.JUN.2021 19:06:03

3DH5\_Ant1\_Low\_2402

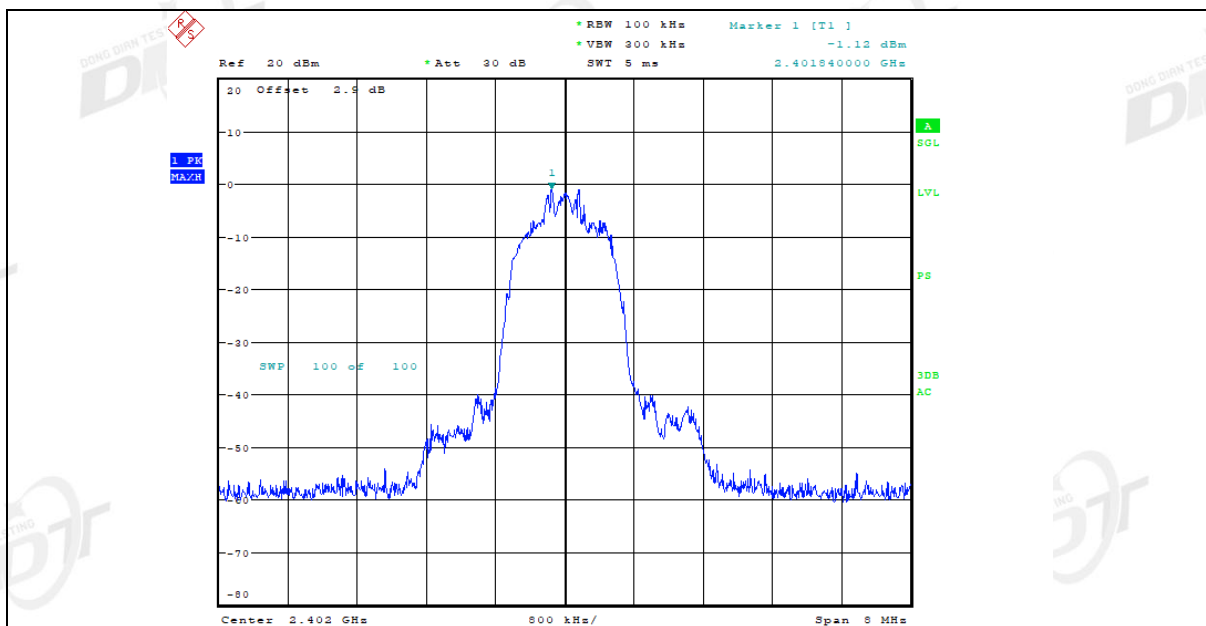

Date: 10.JUN.2021 19:18:24

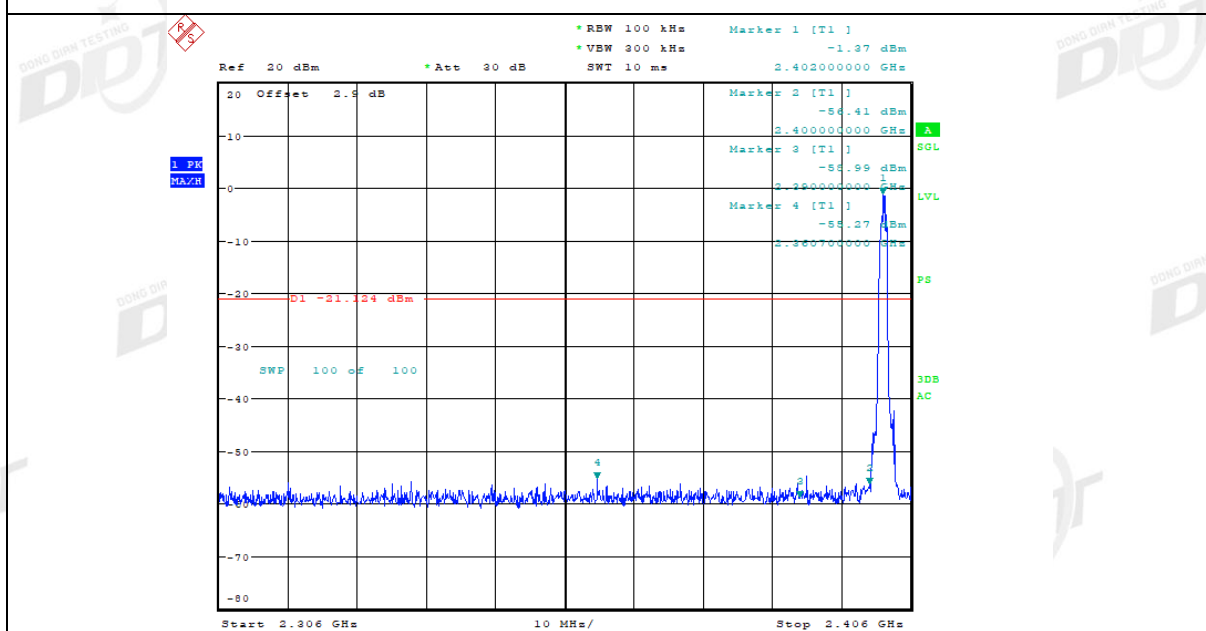

Date: 10.JUN.2021 19:18:28

3DH5\_Ant1\_High\_2480

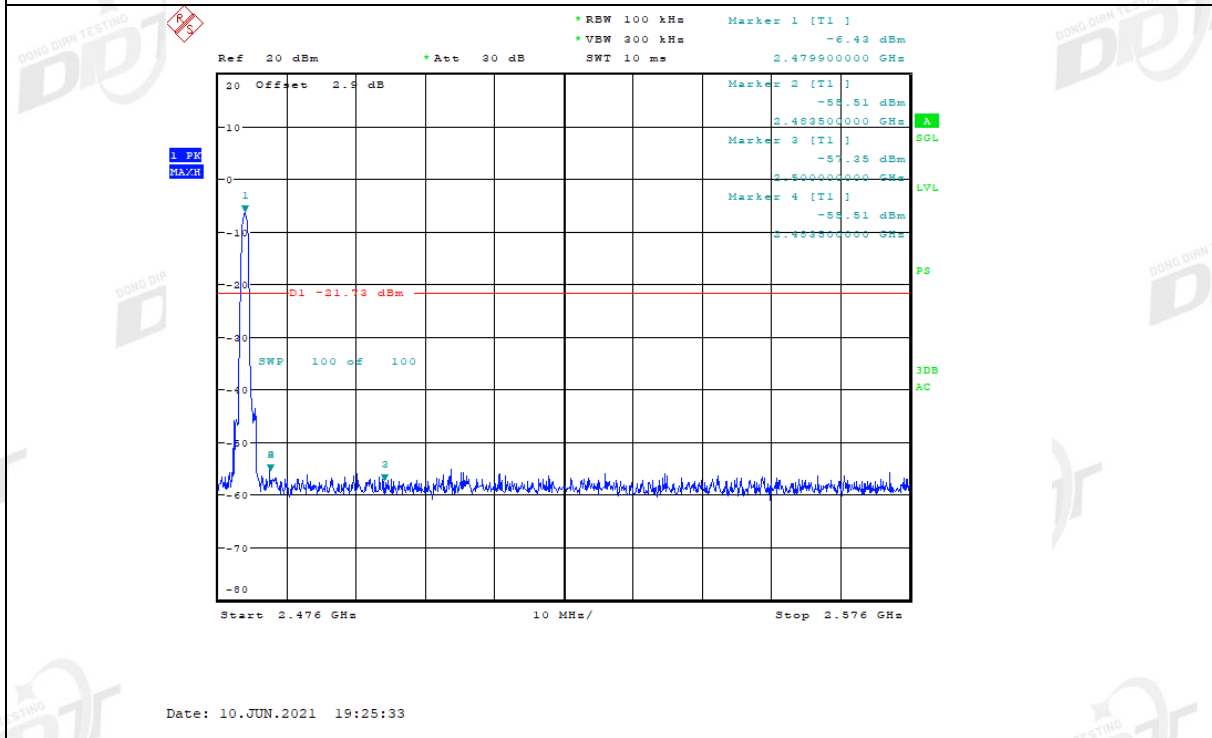
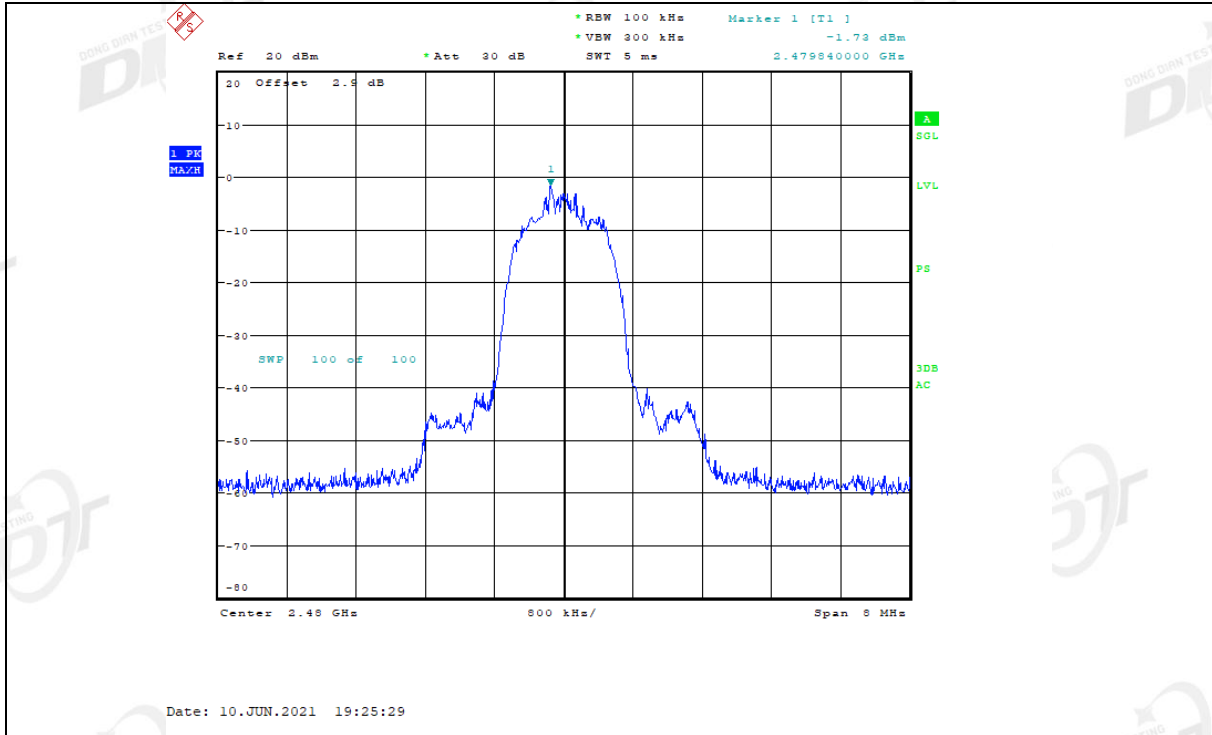

3DH5\_Ant1\_Low\_Hop\_2402

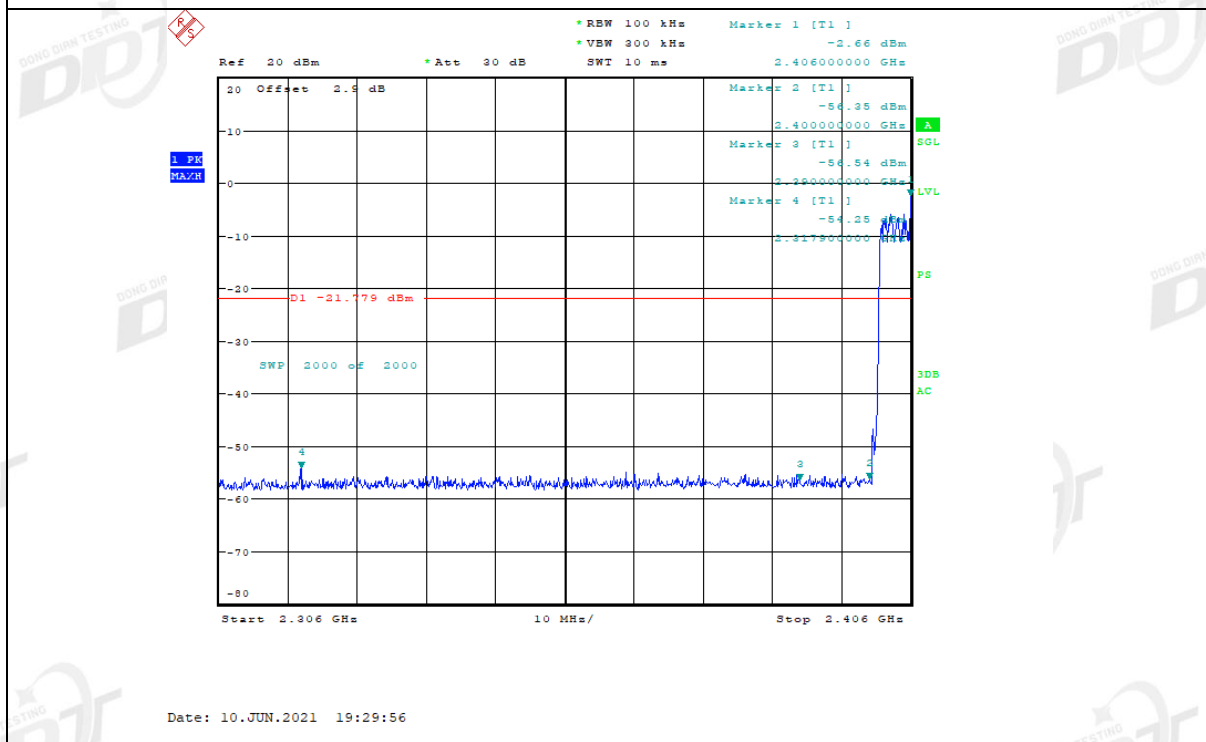
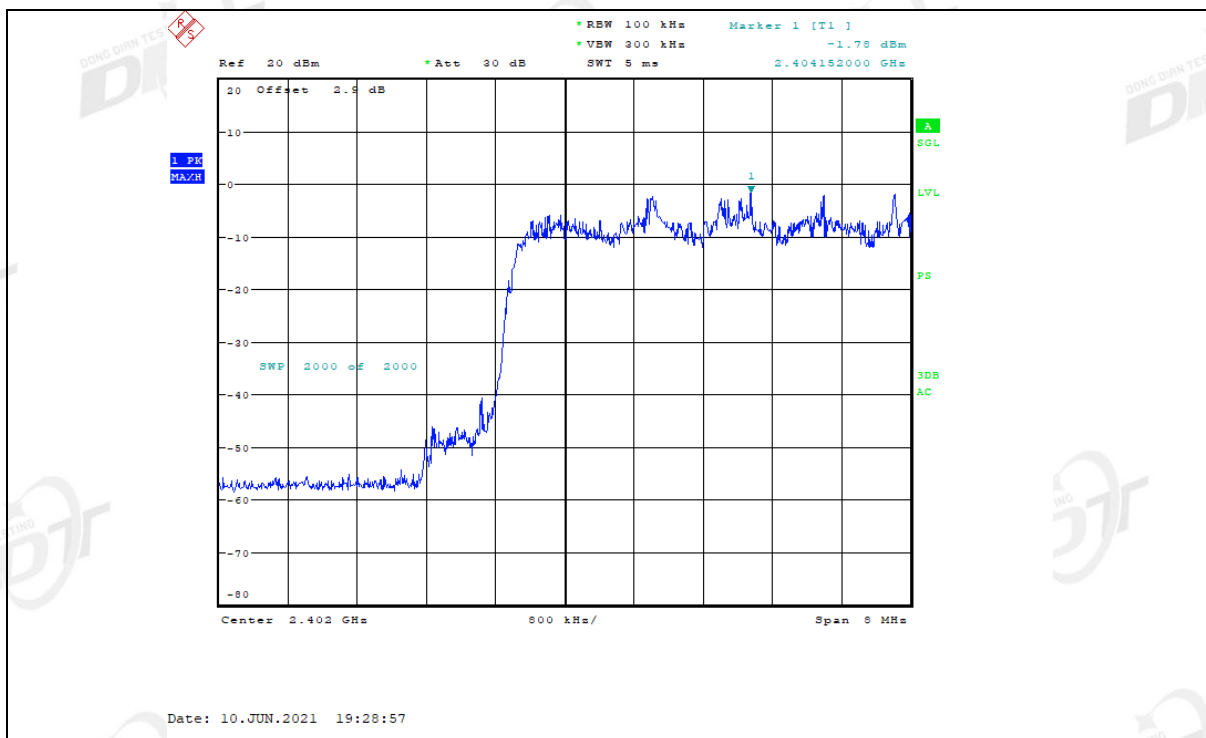

3DH5\_Ant1\_High\_Hop\_2480

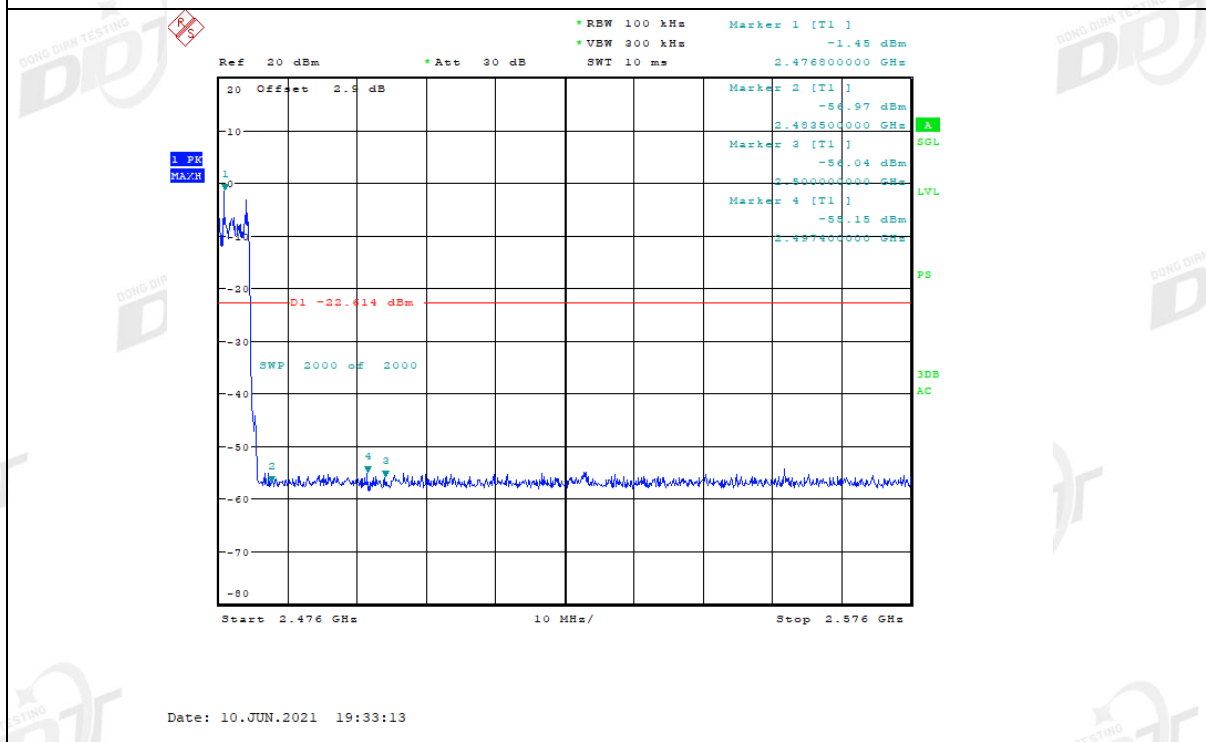
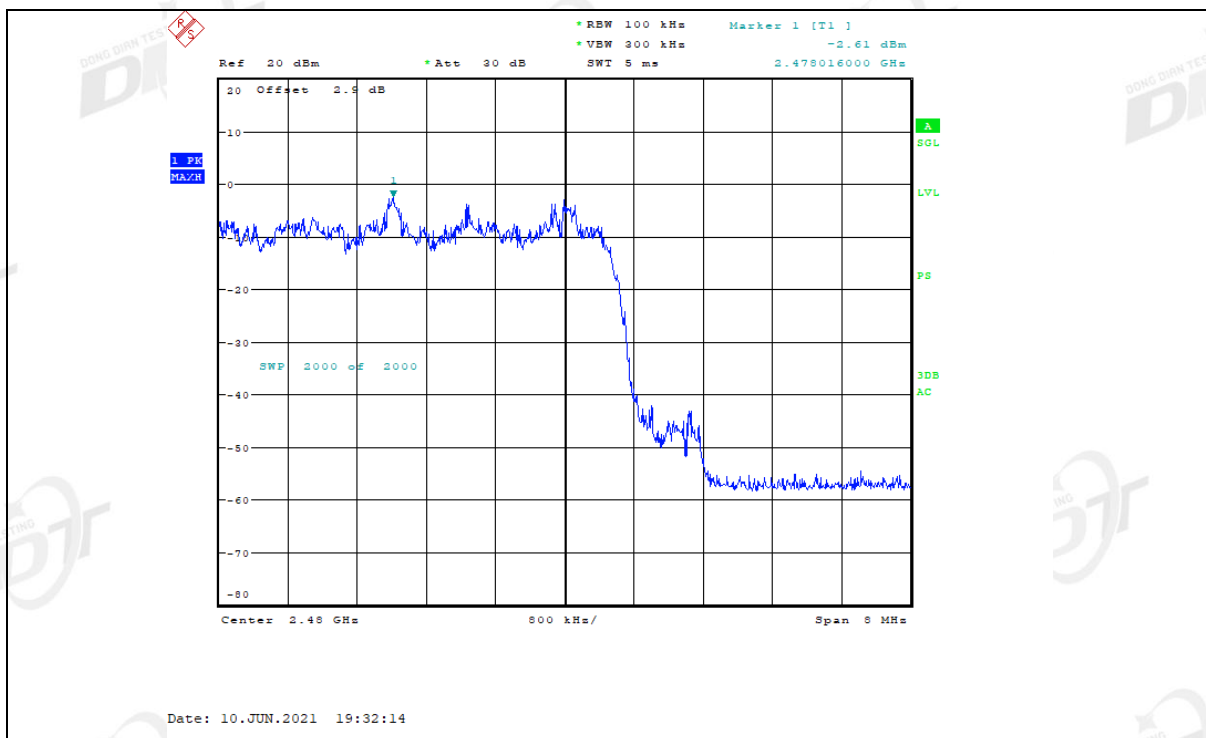

## 10. Radiated Emission

### 10.1. Block diagram of test setup

In 3 m Anechoic Chamber, test setup diagram for 9 kHz - 30 MHz:

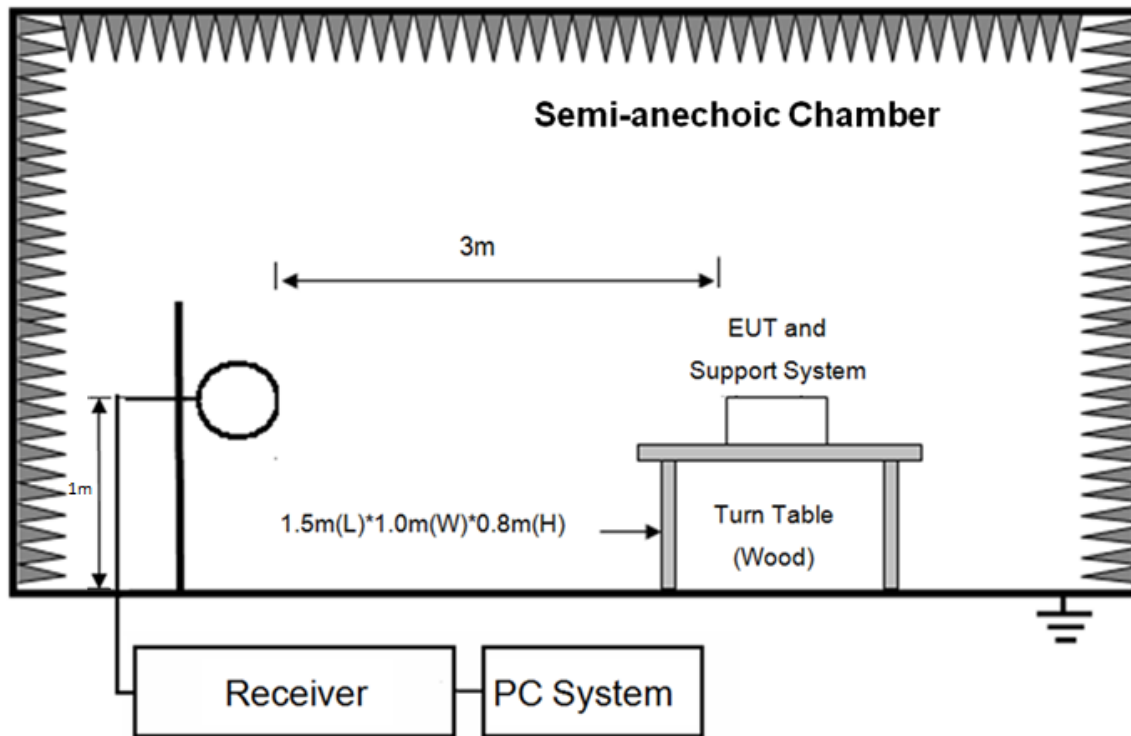

In 3 m Anechoic Chamber, test setup diagram for 30 MHz - 1 GHz:

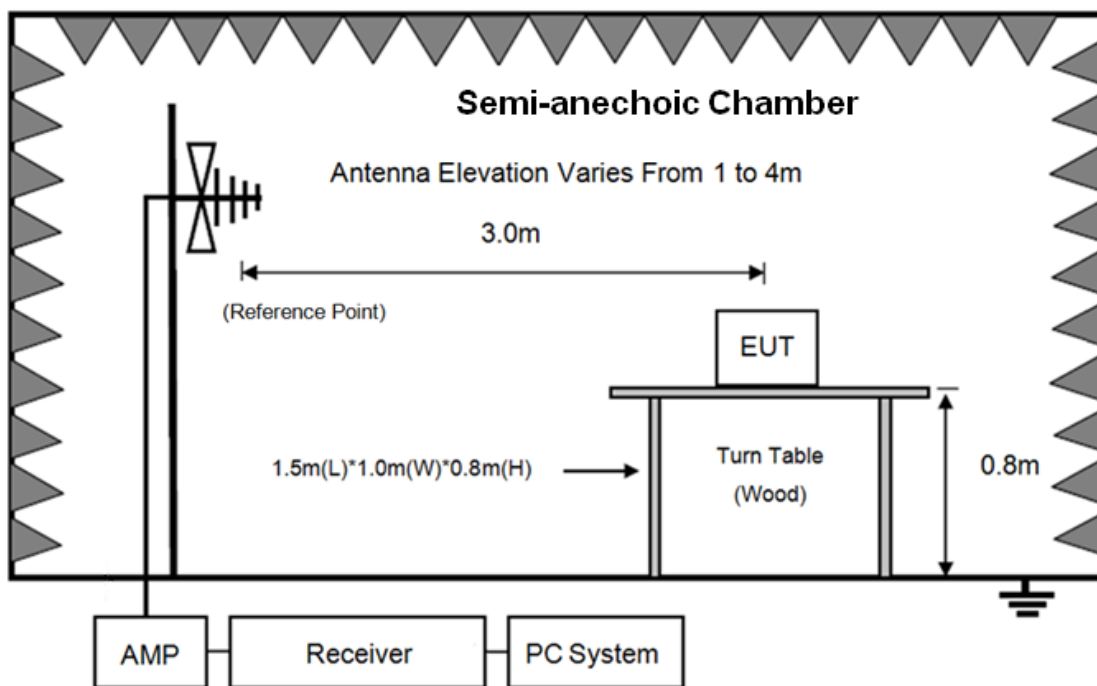

In 3 m Anechoic Chamber, test setup diagram for frequency above 1 GHz:

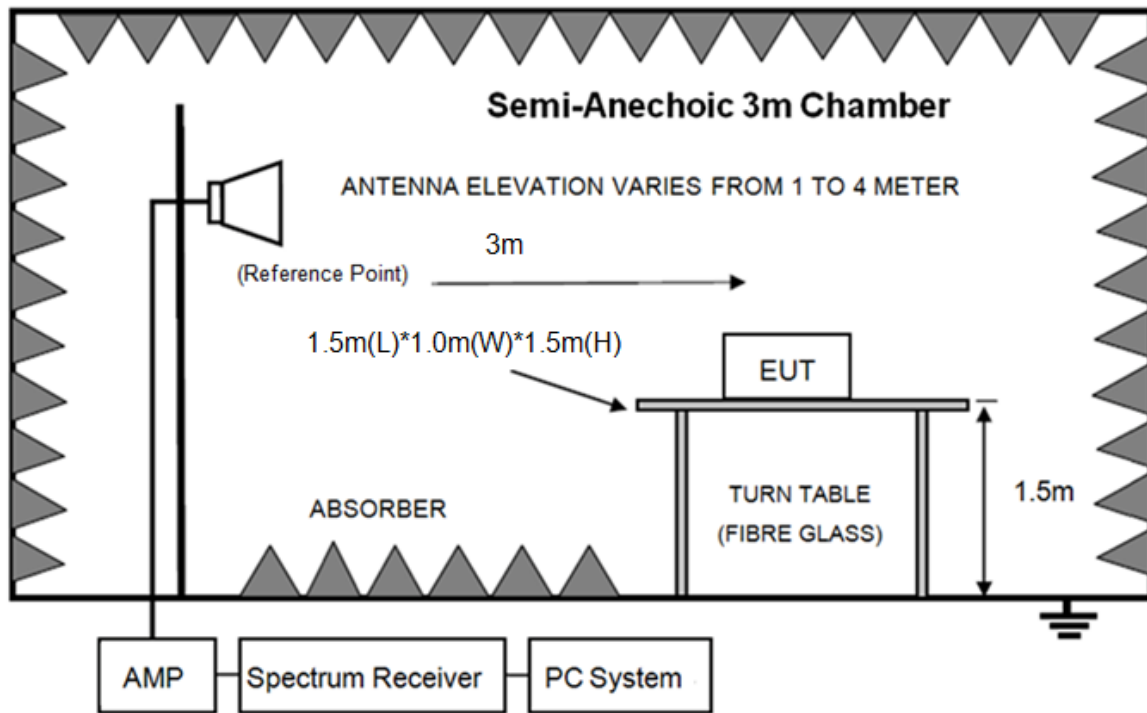

Note: For harmonic emissions test an appropriate high pass filter was inserted in the input port of AMP.

### 10.2. Limit

(1) FCC 15.205 Restricted frequency band

MHz	MHz	MHz	GHz
0.090-0.110	16.42-16.423	399.9-410	4.5-5.15
<sup>1</sup> 0.495-0.505	16.69475-16.69525	608-614	5.35-5.46
2.1735-2.1905	16.80425-16.80475	960-1240	7.25-7.75
4.125-4.128	25.5-25.67	1300-1427	8.025-8.5
4.1772&4.17775	37.5-38.25	1435-1626.5	9.0-9.2
4.2072&4.20775	73-74.6	1645.5-1646.5	9.3-9.5
6.215-6.218	74.8-75.2	1660-1710	10.6-12.7
6.26775-6.26825	108-121.94	1718.8-1722.2	13.25-13.4
6.31175-6.31225	123-138	2200-2300	14.47-14.5
8.291-8.294	149.9-150.05	2310-2390	15.35-16.2
8.362-8.366	156.52475-156.52525	2483.5-2500	17.7-21.4
8.37625-8.38675	156.7-156.9	2690-2900	22.01-23.12
8.41425-8.41475	162.0125-167.17	3260-3267	23.6-24.0
12.29-12.293	167.72-173.2	3332-3339	31.2-31.8
12.51975-12.52025	240-285	3345.8-3358	36.43-36.5
12.57675-12.57725	322-335.4	3600-4400	( <sup>2</sup> )
13.36-13.41			

<sup>1</sup>Until February 1, 1999, this restricted band shall be 0.490-0.510 MHz.

<sup>2</sup>Above 38.6



## (2) FCC 15.209 Limit.

FREQUENCY MHz	DISTANCE Meters	FIELD STRENGTHS LIMIT	
		$\mu\text{V}/\text{m}$	$\text{dB}(\mu\text{V})/\text{m}$
0.009 ~ 0.490	300	2400/F(kHz)	67.6-20log(F)
0.490 ~ 1.705	30	24000/F(kHz)	87.6-20log(F)
1.705 ~ 30.0	30	30	29.54
30 ~ 88	3	100	40.0
88 ~ 216	3	150	43.5
216 ~ 960	3	200	46.0
960 ~ 1000	3	500	54.0
Above 1000	3	74.0 $\text{dB}(\mu\text{V})/\text{m}$ (Peak) 54.0 $\text{dB}(\mu\text{V})/\text{m}$ (Average)	

Note: (1) The emission limits shown in the above table are based on measurements employing a CISPR QP detector except for the frequency bands 9 - 90 kHz, 110 - 490 kHz and above 1000 MHz, radiated emissions limits in these three bands are based on measurements employing an average detector.

(2) At frequencies below 30 MHz, measurement may be performed at a distance closer than that specified, and the limit at closer measurement distance can be extrapolated by below formula:

$$\text{Limit}_{3\text{m}}(\text{dB}\mu\text{V}/\text{m}) = \text{Limit}_{30\text{m}}(\text{dB}\mu\text{V}/\text{m}) + 40\text{Log}(30\text{m}/3\text{m})$$

## (3) Limit for this EUT

All the emissions appearing within 15.205 restricted frequency bands shall not exceed the limits shown in 15.209, all the other emissions shall be at least 20 dB below the fundamental emissions or comply with 15.209 limits.

**10.3. Test Procedure**

- (1) EUT was placed on a non-metallic table, 80 cm above the ground plane inside a semi-anechoic chamber for below 1G and 150 cm above the ground plane inside a fully-anechoic chamber for above 1G.
- (2) Test antenna was located 3 m from the EUT on an adjustable mast, and the antenna used as below table.

Test frequency range	Test antenna used	Test antenna distance
9 kHz - 30 MHz	Active Loop antenna	3 m
30 MHz - 1 GHz	Trilog Broadband Antenna	3 m
1 GHz - 18 GHz	Double Ridged Horn Antenna (1 GHz - 18 GHz)	3 m
18 GHz - 40 GHz	Horn Antenna (18 GHz - 40 GHz)	1 m

According ANSI C63.10:2013 clause 6.4.4.2 and 6.5.3, for measurements below 30 MHz, the loop antenna was positioned with its plane vertical from the EUT and rotated about its vertical axis for maximum response at each azimuth position around the EUT. And the loop antenna also

is positioned with its plane horizontal at the specified distance from the EUT. The center of the loop is 1 m above the ground. For measurement above 30 MHz, the trilob Broadband Antenna or Horn Antenna was located 3 m from EUT, Measurements were made with the antenna positioned in both the horizontal and vertical planes of Polarization, and the measurement antenna was varied from 1 m to 4 m. in height above the reference ground plane to obtain the maximum signal strength.

(3) Below pre-scan procedure was first performed in order to find prominent frequency spectrum radiated emissions from 9 kHz to 25 GHz:

(a) Scanning the peak frequency spectrum with the antenna specified in step (3), and the EUT was rotated 360 degree, the antenna height was varied from 1 m to 4 m (Except loop antenna, it's fixed 1 m above ground.)

(b) Change work frequency or channel of device if practicable.

(c) Change modulation type of device if practicable.

(d) Change power supply range from 85% to 115% of the rated supply voltage

(e) Rotated EUT though three orthogonal axes to determine the attitude of EUT arrangement produces highest emissions.

Spectrum frequency from 9 kHz to 25 GHz (tenth harmonic of fundamental frequency) was investigated, and no any obvious emission were detected from 18 GHz to 25 GHz, so below final test was performed with frequency range from 9 kHz to 18 GHz.

(4) For final emissions measurements at each frequency of interest, the EUT was rotated and the antenna height was varied between 1 m and 4 m in order to maximize the emission. Measurements in both horizontal and vertical polarities were made and the data was recorded. In order to find the maximum emission, the relative positions of equipment and all of the interface cables were changed according to ANSI C63.10:2013 on Radiated Emission test.

(5) The emissions from 9 kHz to 1 GHz were measured based on CISPR QP detector except for the frequency bands 9 - 90 kHz, 110 - 490 kHz, for emissions from 9 kHz - 90 kHz, 110 kHz - 490 kHz and above 1 GHz were measured based on average detector, for emissions above 1 GHz, peak emissions also be measured and need comply with Peak limit.

(6) The emissions from 9 kHz to 1 GHz, QP or average values were measured with EMI receiver with below RBW.

Frequency band	RBW
9 kHz - 150 kHz	200 Hz
150 kHz - 30 MHz	9 kHz
30 MHz - 1 GHz	120 kHz

(7) For emissions above 1GHz, both Peak and Average level were measured with Spectrum Analyzer, and the RBW is set at 1 MHz, VBW is set at 3 MHz for Peak measure; According ANSI C63.10:2013 clause 4.1.4.2.2 procedure for average measure.

(8) X axis, Y axis, Z axis are tested, and worse setup X axis is reported.

#### 10.4. Test result

Pass. (See below detailed test result)

All the emissions except fundamental emission from 9 kHz to 25 GHz were comply with 15.209 limits.

Note1: According exploratory test, the emission levels are 20 dB below the limit detected from 9 kHz to 30 MHz and 18 GHz to 25 GHz, so the final test was performed with frequency range from 30 MHz to 18 GHz and recorded in below.

Note2: For emissions below 1 GHz, according exploratory explorer test, when change Tx mode and channel, have no distinct influence on emissions level, so for emissions below 1 GHz, the final test was only performed with EUT working in right side GFSK, Tx 2402 MHz mode.

Note3: For emissions above 1 GHz. If peak results comply with AV limit, AV Result is deemed to comply with AV limit.

## Radiated Emission test (below 1 GHz) TR-4-E-009 Radiated Emission Test Result

**Test Site** : DDT 3m Chamber 2#  
**Test Date** : 2021-06-04      **Tested By** : Sunny  
**EUT** : Du smart buds      **Model Number** : XD-SWA14-2101  
**Power Supply** : Battery      **Test Mode** : BT mode  
**Condition** : Temp:24.5°C,Humi:55%,Press:100.1kPa      **Antenna/Distance** : 2021 VULB 9163 2#/3m/HORIZONTAL  
**Memo** :

Data: 7

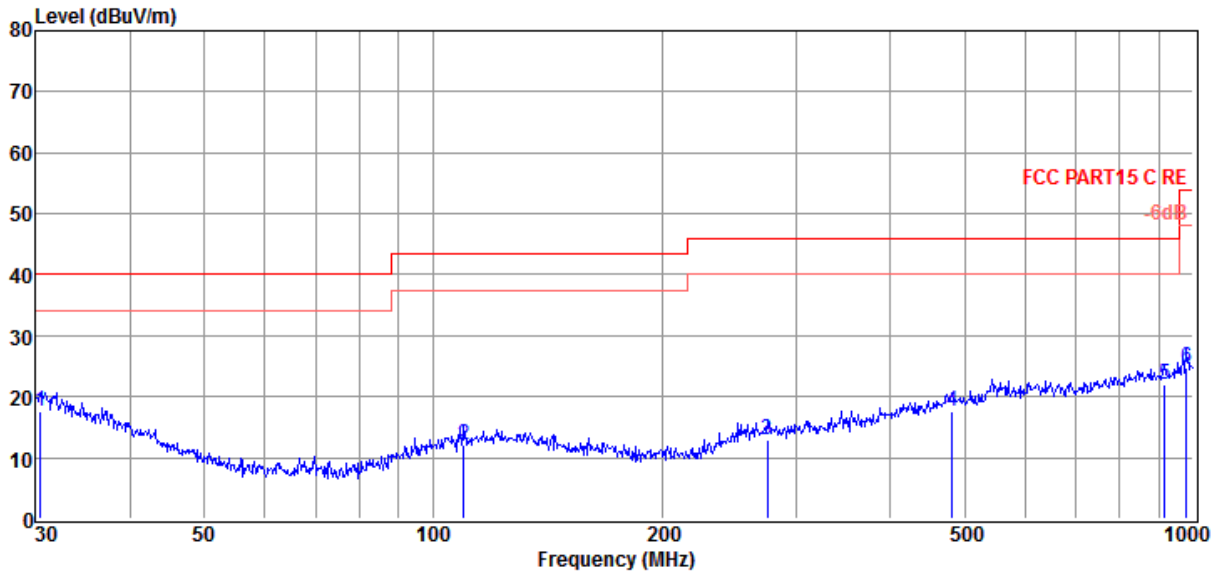

Item (Mark)	Freq. (MHz)	Read Level (dBμV)	Antenna Factor (dB/m)	Cable Loss (dB)	Result Level (dBμV/m)	Limit Line (dBμV/m)	Over Limit (dB)	Detector	Polarization
1	30.42	22.32	24.69	-29.38	17.63	40.00	-22.37	QP	HORIZONTAL
2	109.80	23.03	17.69	-28.74	11.98	43.50	-31.52	QP	HORIZONTAL
3	275.16	21.77	18.61	-27.56	12.82	46.00	-33.18	QP	HORIZONTAL
4	482.22	20.77	23.30	-26.34	17.73	46.00	-28.27	QP	HORIZONTAL
5	916.07	19.32	26.50	-23.89	21.93	46.00	-24.07	QP	HORIZONTAL
6	979.18	20.55	27.00	-22.85	24.70	54.00	-29.30	QP	HORIZONTAL

- Note: 1. Result Level = Read Level + Antenna Factor + Cable loss.  
 2. If Peak Result complies with QP limit, QP Result is deemed to comply with QP limit.  
 3. Test setup: RBW: 120 kHz, VBW: 300 kHz, Sweep time: auto.

## TR-4-E-009 Radiated Emission Test Result

**Test Site** : DDT 3m Chamber 2#  
**Test Date** : 2021-06-04 **Tested By** : Sunny  
**EUT** : Du smart buds **Model Number** : XD-SWA14-2101  
**Power Supply** : Battery **Test Mode** : BT mode  
**Condition** : Temp:24.5°C,Humi:55%,Press:100.1kPa **Antenna/Distance** : 2021 VULB 9163 2#/3m/VERTICAL  
**Memo** :

Data: 8

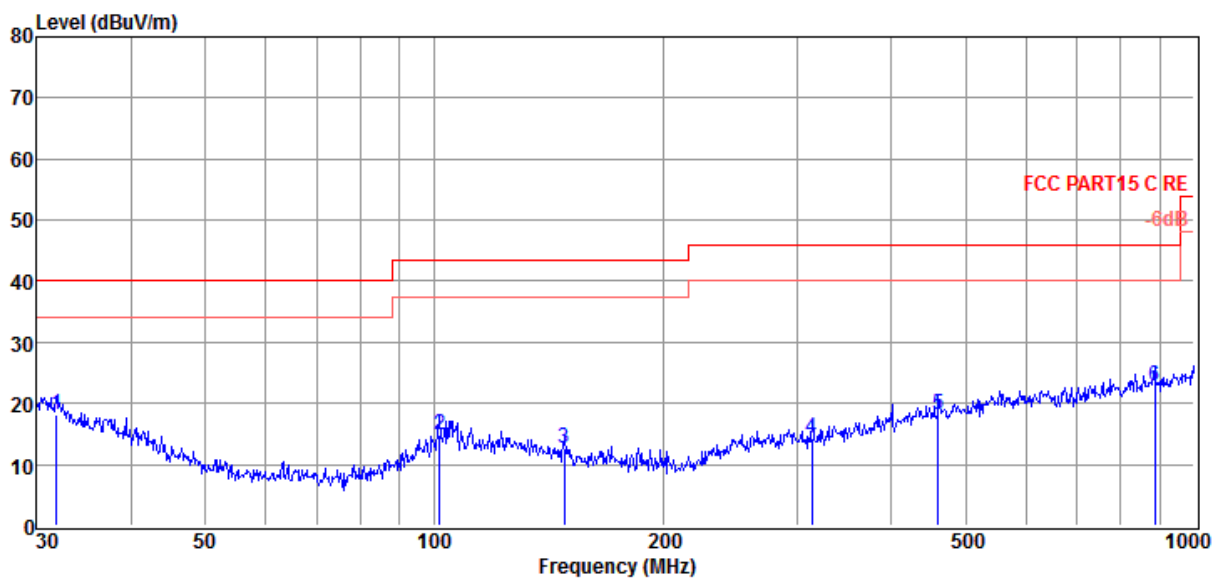

Item (Mark)	Freq. (MHz)	Read Level (dBμV)	Antenna Factor (dB/m)	Cable Loss (dB)	Result Level (dBμV/m)	Limit Line (dBμV/m)	Over Limit (dB)	Detector	Polarization
1	31.84	23.52	23.89	-29.33	18.08	40.00	-21.92	QP	VERTICAL
2	101.64	26.44	17.10	-28.75	14.79	43.50	-28.71	QP	VERTICAL
3	148.44	24.54	16.49	-28.36	12.67	43.50	-30.83	QP	VERTICAL
4	314.38	22.13	19.54	-27.42	14.25	46.00	-31.75	QP	VERTICAL
5	460.73	21.76	22.91	-26.46	18.21	46.00	-27.79	QP	VERTICAL
6	887.61	20.67	26.42	-24.34	22.75	46.00	-23.25	QP	VERTICAL

Note: 1. Result Level = Read Level + Antenna Factor + Cable loss.

2. If Peak Result complies with QP limit, QP Result is deemed to comply with QP limit.

3. Test setup: RBW: 120 kHz, VBW: 300 kHz, Sweep time: auto.

**Radiated Emission test (above 1 GHz)**

Left side

Freq. (MHz)	Read level (dB $\mu$ V)	Antenna Factor (dB/m)	PRM Factor (dB)	Cable Loss (dB)	Result Level (dB $\mu$ V/m)	Limit (dB $\mu$ V/m)	Margin (dB)	Detector type	Polarization
Tx mode 2402 MHz									
4961.00	39.34	32.82	0.00	-32.18	39.98	74.00	-34.02	Peak	HORIZONTAL
7120.00	39.59	36.79	0.00	-31.84	44.54	74.00	-29.46	Peak	HORIZONTAL
9381.00	39.72	37.93	0.00	-30.73	46.92	74.00	-27.08	Peak	HORIZONTAL
11761.00	36.66	38.65	0.00	-29.67	45.64	74.00	-28.36	Peak	HORIZONTAL
13835.00	38.19	41.07	0.00	-29.57	49.69	74.00	-24.31	Peak	HORIZONTAL
17286.00	36.86	42.60	0.00	-28.10	51.36	74.00	-22.64	Peak	HORIZONTAL
4804.00	41.68	32.51	0.00	-32.26	41.93	74.00	-32.07	Peak	VERTICAL
7341.00	40.46	37.15	0.00	-31.53	46.08	74.00	-27.92	Peak	VERTICAL
9789.00	39.90	38.17	0.00	-30.91	47.16	74.00	-26.84	Peak	VERTICAL
12169.00	37.37	38.60	0.00	-29.76	46.21	74.00	-27.79	Peak	VERTICAL
13716.00	39.15	40.83	0.00	-29.55	50.43	74.00	-23.57	Peak	VERTICAL
16555.00	36.93	40.06	0.00	-27.86	49.13	74.00	-24.87	Peak	VERTICAL
Tx mode 2441 MHz									
5250.00	40.54	33.35	0.00	-32.07	41.82	74.00	-32.18	Peak	HORIZONTAL
9415.00	39.41	37.95	0.00	-30.68	46.68	74.00	-27.32	Peak	HORIZONTAL
11540.00	37.17	38.69	0.00	-29.48	46.38	74.00	-27.62	Peak	HORIZONTAL
13716.00	39.89	40.83	0.00	-29.55	51.17	74.00	-22.83	Peak	HORIZONTAL
14515.00	36.50	40.65	0.00	-28.43	48.72	74.00	-25.28	Peak	HORIZONTAL
16844.00	37.03	41.45	0.00	-27.73	50.75	74.00	-23.25	Peak	HORIZONTAL
4882.00	40.36	32.66	0.00	-32.48	40.54	74.00	-33.46	Peak	VERTICAL
7766.00	40.70	37.19	0.00	-31.87	46.02	74.00	-27.98	Peak	VERTICAL
9670.00	39.06	38.10	0.00	-30.81	46.35	74.00	-27.65	Peak	VERTICAL
11710.00	37.37	38.66	0.00	-29.56	46.47	74.00	-27.53	Peak	VERTICAL
13784.00	38.37	40.97	0.00	-29.63	49.71	74.00	-24.29	Peak	VERTICAL
16844.00	37.58	41.45	0.00	-27.73	51.30	74.00	-22.70	Peak	VERTICAL
Tx mode 2480 MHz									
4740.00	39.56	32.38	0.00	-32.20	39.74	74.00	-34.26	Peak	HORIZONTAL
6865.00	39.94	36.38	0.00	-31.83	44.49	74.00	-29.51	Peak	HORIZONTAL
9636.00	39.43	38.08	0.00	-30.84	46.67	74.00	-27.33	Peak	HORIZONTAL
11744.00	37.82	38.65	0.00	-29.64	46.83	74.00	-27.17	Peak	HORIZONTAL
13359.00	39.15	40.15	0.00	-30.12	49.18	74.00	-24.82	Peak	HORIZONTAL
16453.00	36.30	39.68	0.00	-28.04	47.94	74.00	-26.06	Peak	HORIZONTAL
4960.00	40.44	32.82	0.00	-32.18	41.08	74.00	-32.92	Peak	VERTICAL
7766.00	40.64	37.19	0.00	-31.87	45.96	74.00	-28.04	Peak	VERTICAL
9704.00	39.27	38.12	0.00	-30.80	46.59	74.00	-27.41	Peak	VERTICAL
11676.00	38.15	38.66	0.00	-29.46	47.35	74.00	-26.65	Peak	VERTICAL
14379.00	37.15	40.87	0.00	-28.95	49.07	74.00	-24.93	Peak	VERTICAL
16980.00	36.80	42.10	0.00	-27.52	51.38	74.00	-22.62	Peak	VERTICAL
Verdict: Pass									

Note: 1. 30 MHz ~ 25 GHz: (Scan with GFSK,  $\pi/4$ -DQPSK, 8DPSK, the worst case is GFSK Mode)

2. Result Level = Read Level + Antenna Factor + Cable loss - PRM Factor.

3. For emissions above 1GHz. If peak results comply with AV limit, AV Result is deemed to comply with AV limit.

Right side

Freq. (MHz)	Read level (dB $\mu$ V)	Antenna Factor (dB/m)	PRM Factor (dB)	Cable Loss (dB)	Result Level (dB $\mu$ V/m)	Limit (dB $\mu$ V/m)	Margin (dB)	Detector type	Polarization
Tx mode 2402 MHz									
4804.00	47.03	32.51	0.00	-32.26	47.28	74.00	-26.72	Peak	HORIZONTAL
7086.00	39.35	36.74	0.00	-31.84	44.25	74.00	-29.75	Peak	HORIZONTAL
9262.00	40.50	37.86	0.00	-31.39	46.97	74.00	-27.03	Peak	HORIZONTAL
10724.00	37.40	38.59	0.00	-30.19	45.80	74.00	-28.20	Peak	HORIZONTAL
13784.00	38.53	40.97	0.00	-29.63	49.87	74.00	-24.13	Peak	HORIZONTAL
17456.00	36.18	42.84	0.00	-28.45	50.57	74.00	-23.43	Peak	HORIZONTAL
4804.00	43.59	32.51	0.00	-32.26	43.84	74.00	-30.16	Peak	VERTICAL
7545.00	39.87	37.36	0.00	-31.73	45.50	74.00	-28.50	Peak	VERTICAL
9585.00	39.30	38.05	0.00	-30.92	46.43	74.00	-27.57	Peak	VERTICAL
12101.00	37.52	38.60	0.00	-29.75	46.37	74.00	-27.63	Peak	VERTICAL
13716.00	38.52	40.83	0.00	-29.55	49.80	74.00	-24.20	Peak	VERTICAL
17439.00	37.45	42.81	0.00	-28.46	51.80	74.00	-22.20	Peak	VERTICAL
Tx mode 2441 MHz									
4882.00	42.32	32.66	0.00	-32.48	42.50	74.00	-31.50	Peak	HORIZONTAL
7341.00	39.23	37.15	0.00	-31.53	44.85	74.00	-29.15	Peak	HORIZONTAL
9109.00	40.10	37.77	0.00	-31.75	46.12	74.00	-27.88	Peak	HORIZONTAL
10571.00	38.37	38.53	0.00	-30.41	46.49	74.00	-27.51	Peak	HORIZONTAL
12101.00	37.21	38.60	0.00	-29.75	46.06	74.00	-27.94	Peak	HORIZONTAL
14311.00	36.70	40.96	0.00	-28.97	48.69	74.00	-25.31	Peak	HORIZONTAL
5029.00	39.27	32.95	0.00	-32.08	40.14	74.00	-33.86	Peak	VERTICAL
7749.00	40.49	37.20	0.00	-31.81	45.88	74.00	-28.12	Peak	VERTICAL
9636.00	39.22	38.08	0.00	-30.84	46.46	74.00	-27.54	Peak	VERTICAL
12220.00	38.00	38.60	0.00	-29.85	46.75	74.00	-27.25	Peak	VERTICAL
13954.00	37.70	41.31	0.00	-29.32	49.69	74.00	-24.31	Peak	VERTICAL
17031.00	36.08	42.24	0.00	-27.70	50.62	74.00	-23.38	Peak	VERTICAL
Tx mode 2480 MHz									
4960.00	40.67	32.82	0.00	-32.18	41.31	74.00	-32.69	Peak	HORIZONTAL
7511.00	39.19	37.39	0.00	-31.75	44.83	74.00	-29.17	Peak	HORIZONTAL
9840.00	39.12	38.20	0.00	-30.95	46.37	74.00	-27.63	Peak	HORIZONTAL
11149.00	37.81	38.70	0.00	-29.61	46.90	74.00	-27.10	Peak	HORIZONTAL
14124.00	37.94	41.23	0.00	-29.12	50.05	74.00	-23.95	Peak	HORIZONTAL
17456.00	37.10	42.84	0.00	-28.45	51.49	74.00	-22.51	Peak	HORIZONTAL
4960.00	41.30	32.82	0.00	-32.18	41.94	74.00	-32.06	Peak	VERTICAL
8480.00	40.10	37.38	0.00	-31.80	45.68	74.00	-28.32	Peak	VERTICAL
10044.00	38.54	38.32	0.00	-30.86	46.00	74.00	-28.00	Peak	VERTICAL
12135.00	37.20	38.60	0.00	-29.75	46.05	74.00	-27.95	Peak	VERTICAL
13699.00	38.76	40.80	0.00	-29.53	50.03	74.00	-23.97	Peak	VERTICAL
17116.00	36.54	42.36	0.00	-28.25	50.65	74.00	-23.35	Peak	VERTICAL
Verdict: Pass									

Note: 1. 30 MHz ~ 25 GHz: (Scan with GFSK,  $\pi/4$ -DQPSK, 8DPSK, the worst case is GFSK Mode)

2. Result Level = Read Level + Antenna Factor + Cable loss - PRM Factor.

3. For emissions above 1GHz. If peak results comply with AV limit, AV Result is deemed to comply with AV limit.



## 11. RF Conducted Spurious Emissions

### 11.1. Block diagram of test setup

Same as section 4.1

### 11.2. Limits

In any 100 kHz bandwidth outside the frequency bands in which the spread spectrum intentional radiator is operating, the radio frequency power that is produced by the intentional radiator shall be at least 20 dB below that in the 100 kHz bandwidth within the band that contains the highest level of the desired power.

### 11.3. Test procedure

(1) Connect EUT's antenna output to spectrum analyzer by RF cable.

(2) Establish a reference level by using the following procedure:

Center frequency	Test frequency
RBW:	100 kHz
VBW:	300 kHz
Span	Wide enough to capture the peak level of the in-band emission
Detector Mode:	Peak
Sweep time:	auto
Trace mode	Max hold

(3) Allow the trace to stabilize, use the peak marker function to determine the maximum peak power level to establish the reference level.

(4) Set the spectrum analyzer as follows:

RBW:	100 kHz
VBW:	300 kHz
Span	Encompass frequency range to be measured
Number of measurement points	$\geq \text{span}/\text{RBW}$
Detector Mode:	Peak
Sweep time:	auto
Trace mode	Max hold

(5) Allow the trace to stabilize, use the peak marker function to determine the maximum amplitude of all unwanted emissions outside of the authorized frequency band

### 11.4. Test result

Mode	Freq. (MHz)	Verdict
GFSK	Hopping off 2402	Pass
	Hopping off 2441	Pass
	Hopping off 2480	Pass
$\pi/4$ -DQPSK	Hopping off 2402	Pass
	Hopping off 2441	Pass
	Hopping off 2480	Pass
8DPSK	Hopping off 2402	Pass
	Hopping off 2441	Pass
	Hopping off 2480	Pass

### 11.5. Original test data

Left side:

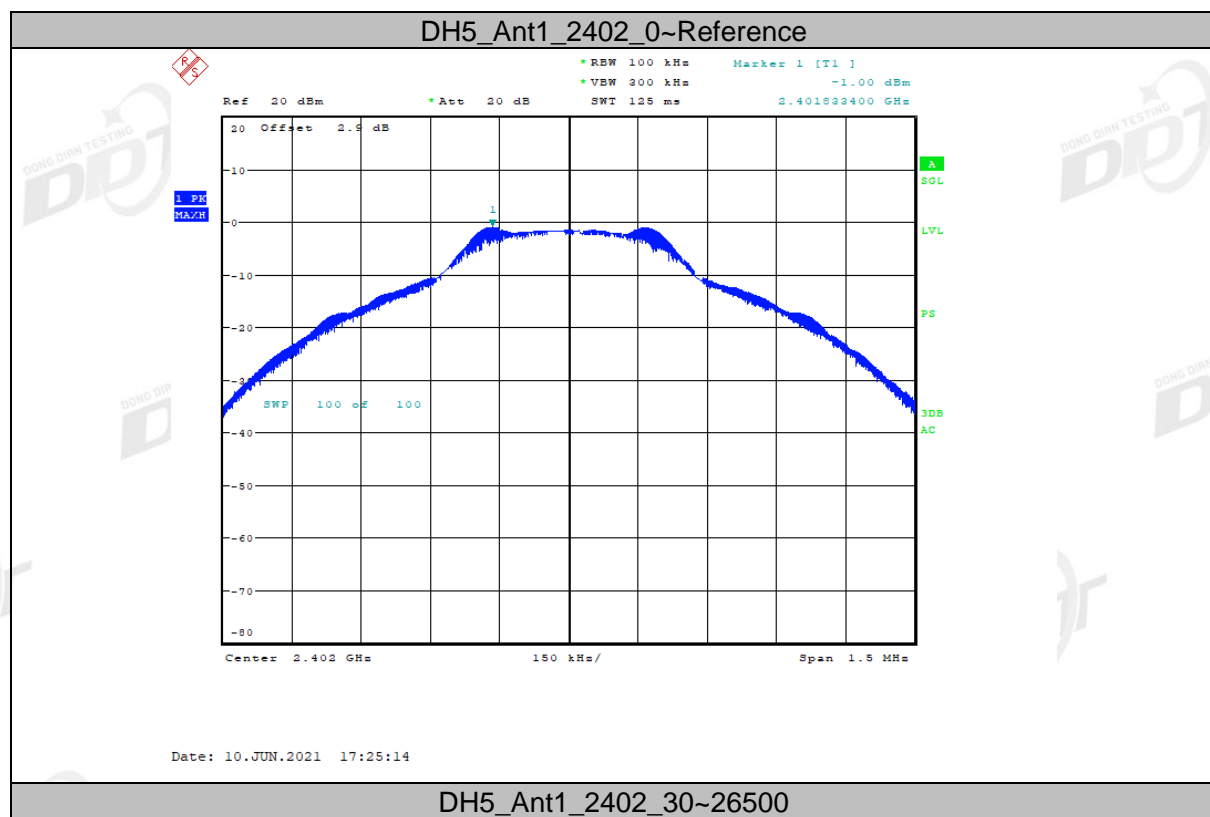

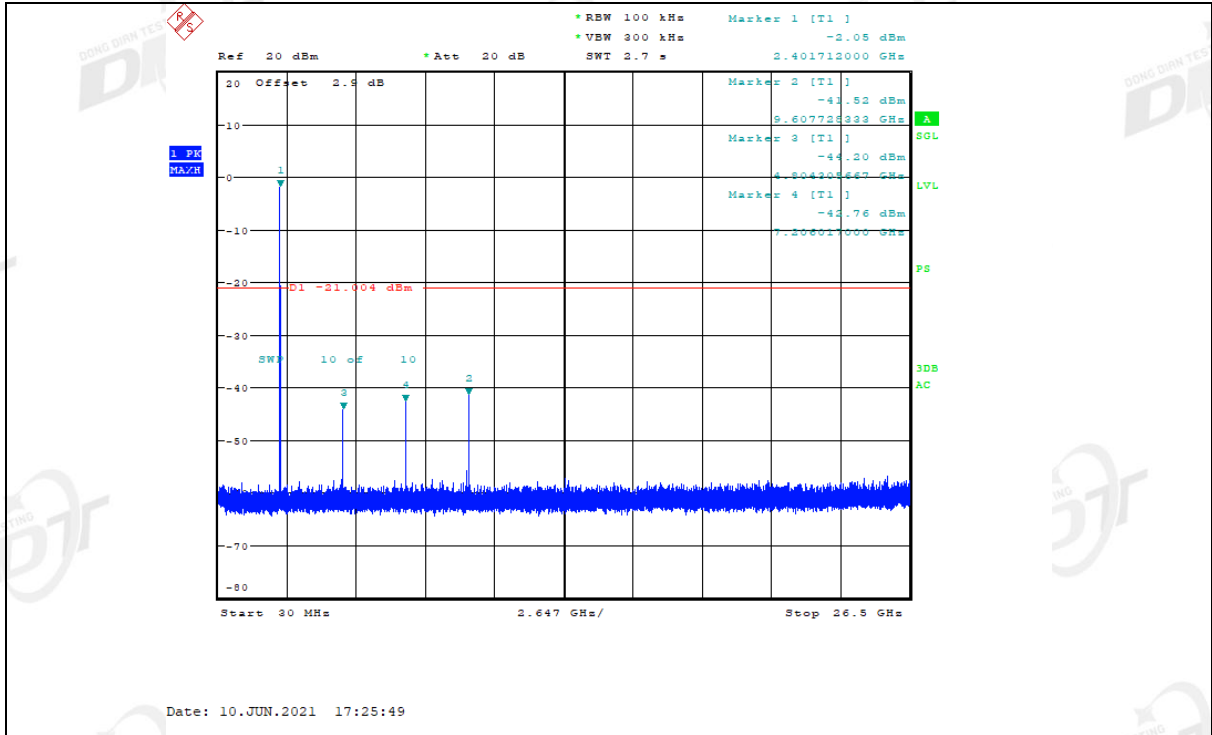

DH5\_Ant1\_2441\_0~Reference

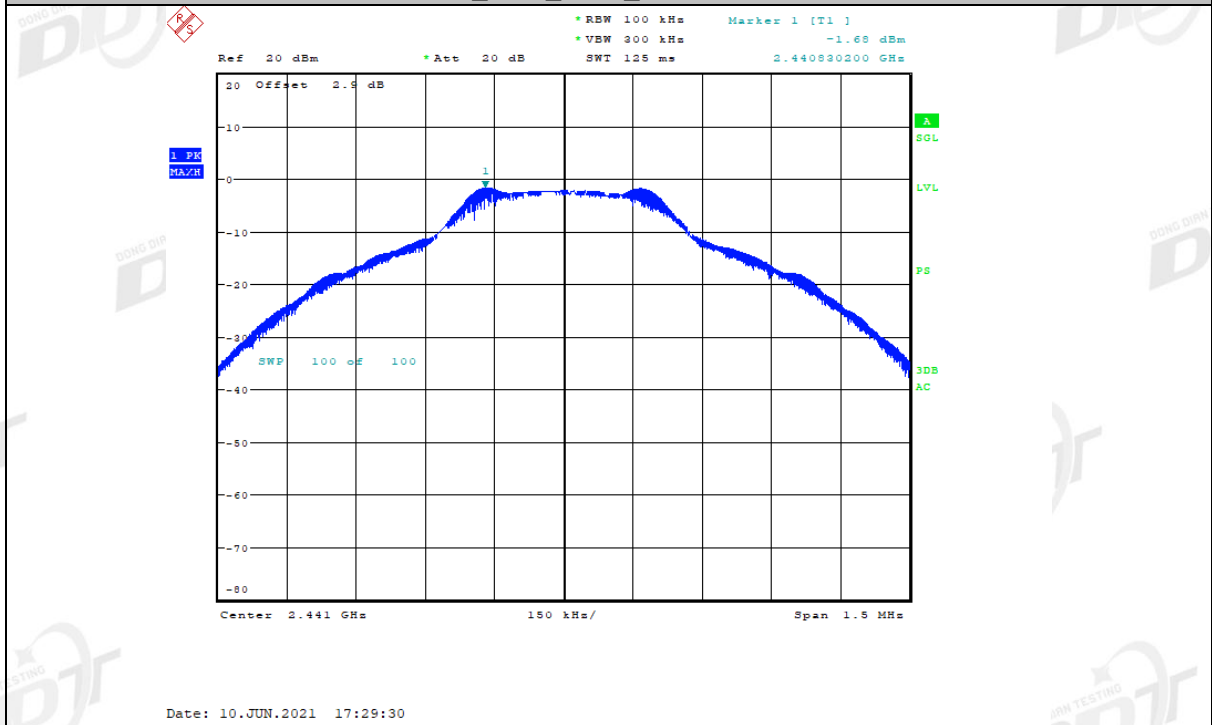

DH5\_Ant1\_2441\_30~26500

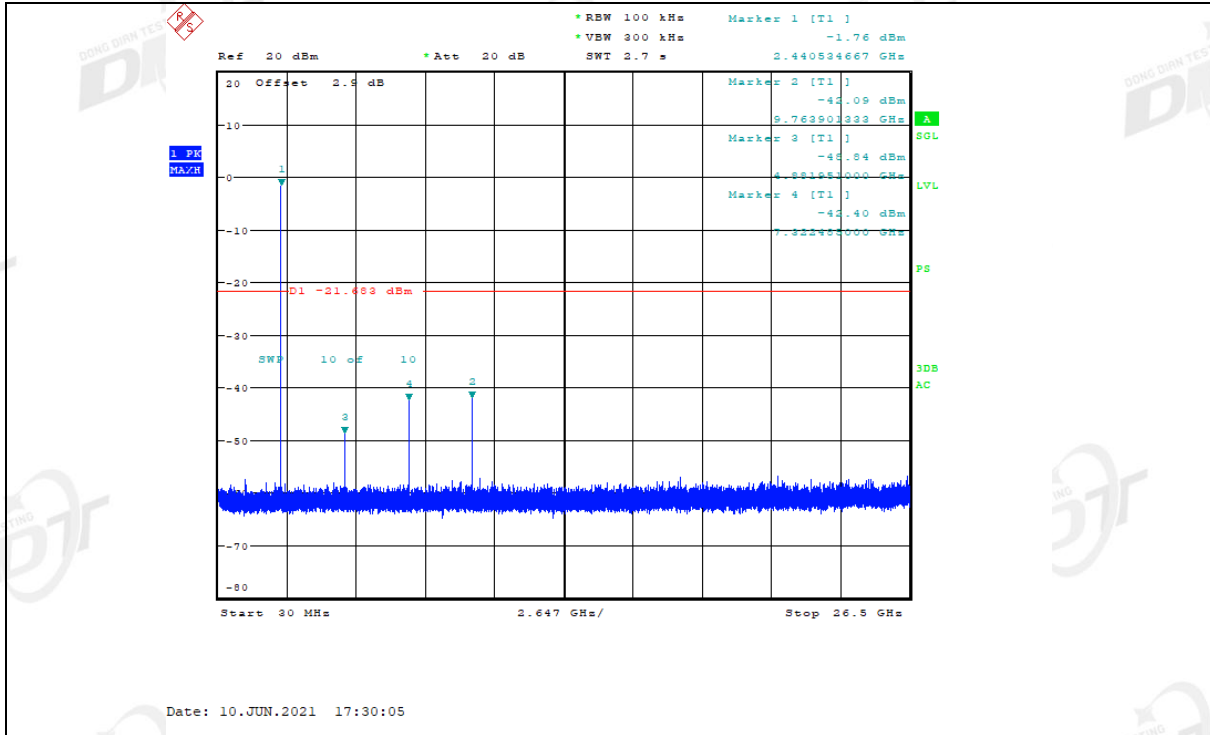

DH5\_Ant1\_2480\_0~Reference

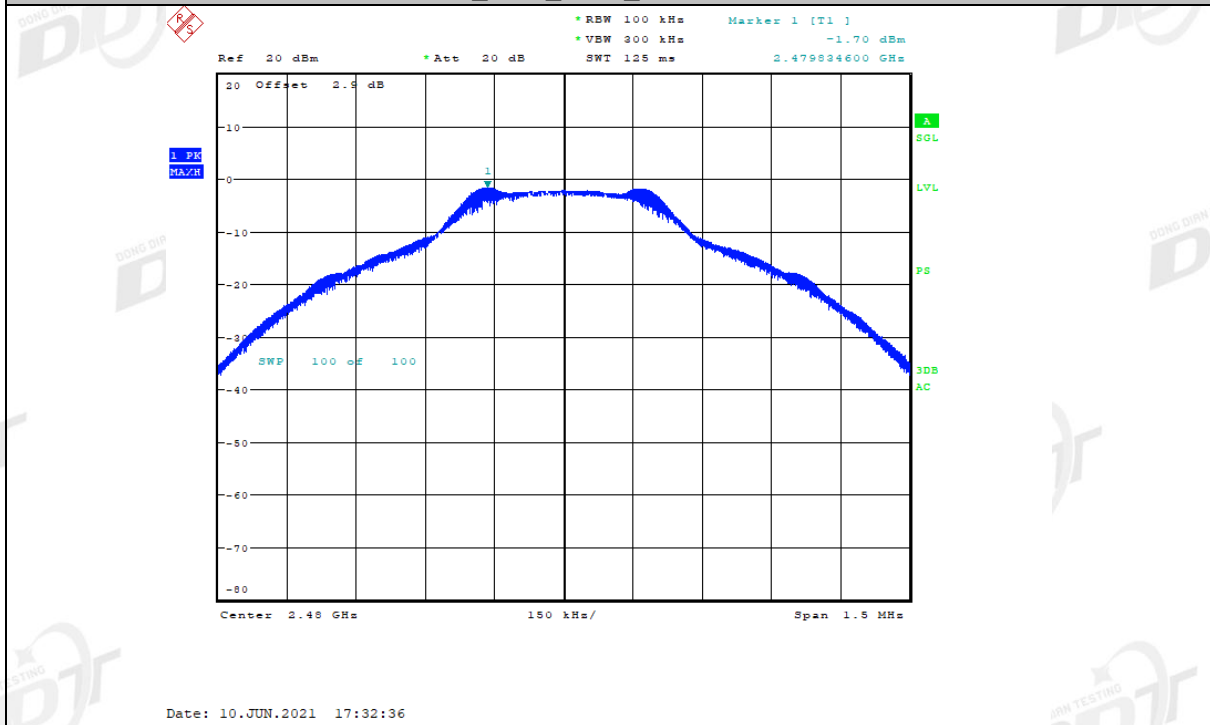

DH5\_Ant1\_2480\_30~26500

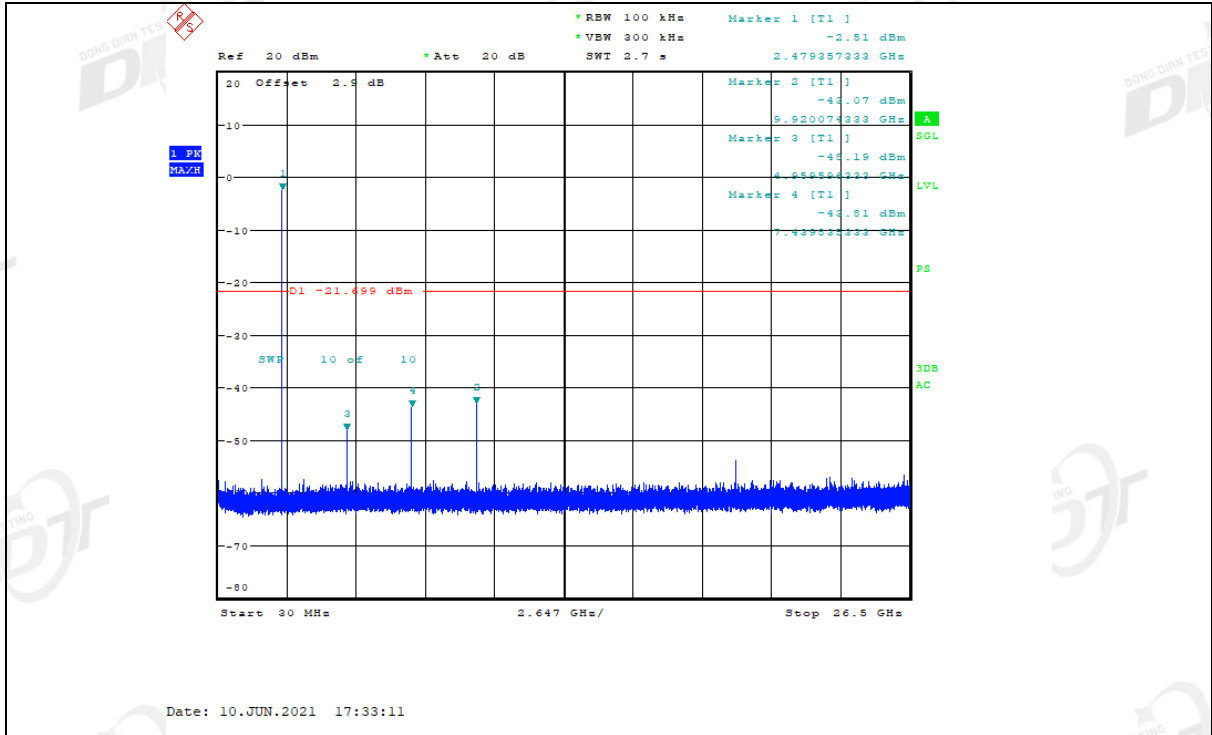

2DH5\_Ant1\_2402\_0-Reference

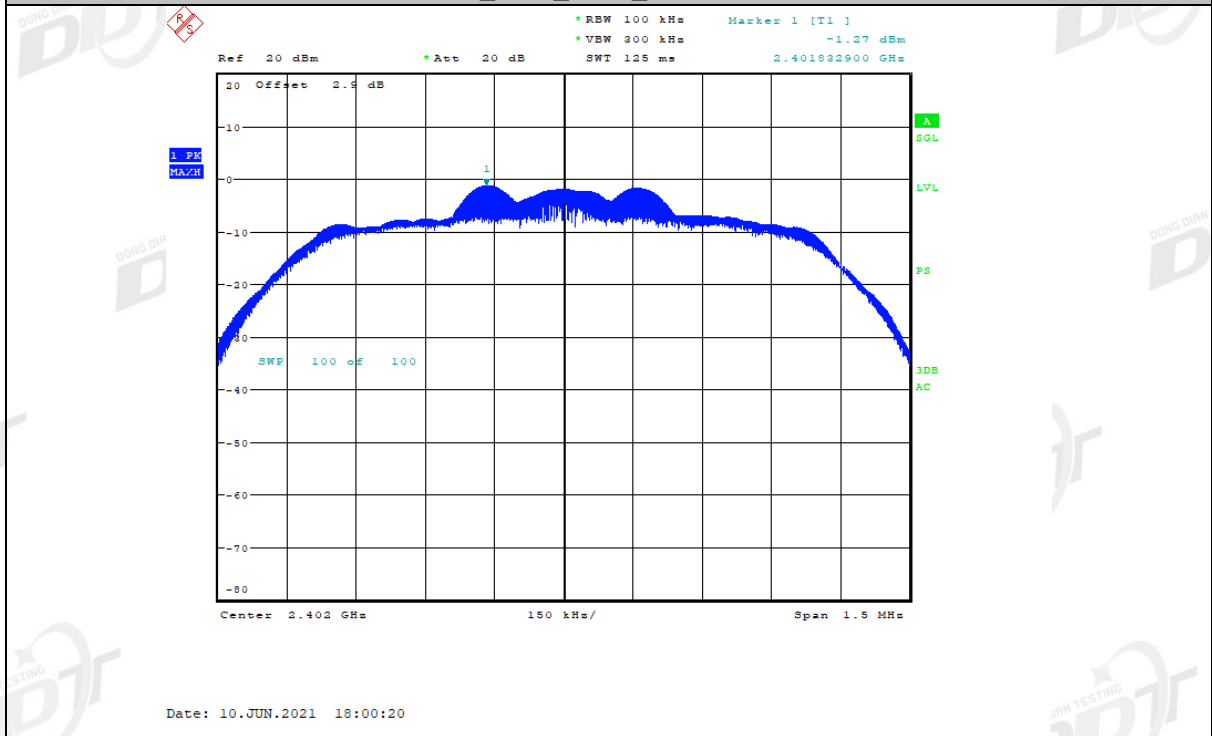

2DH5\_Ant1\_2402\_30~26500

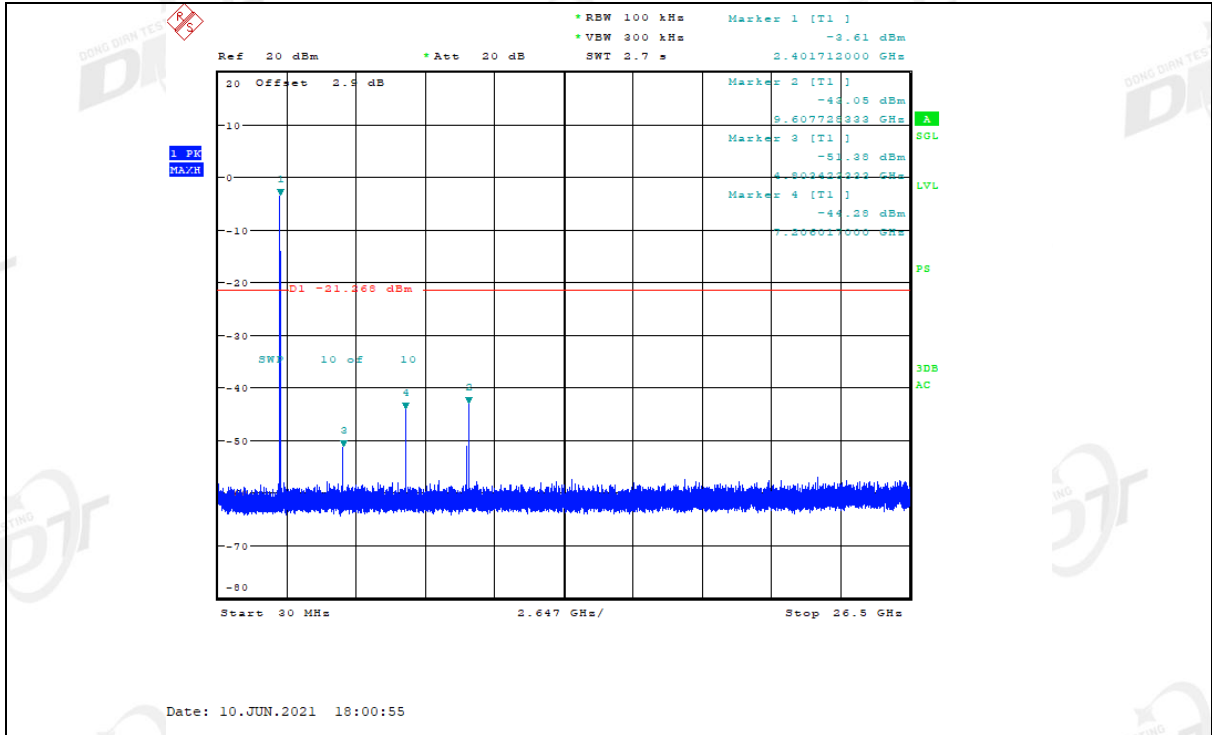

2DH5\_Ant1\_2441\_0-Reference

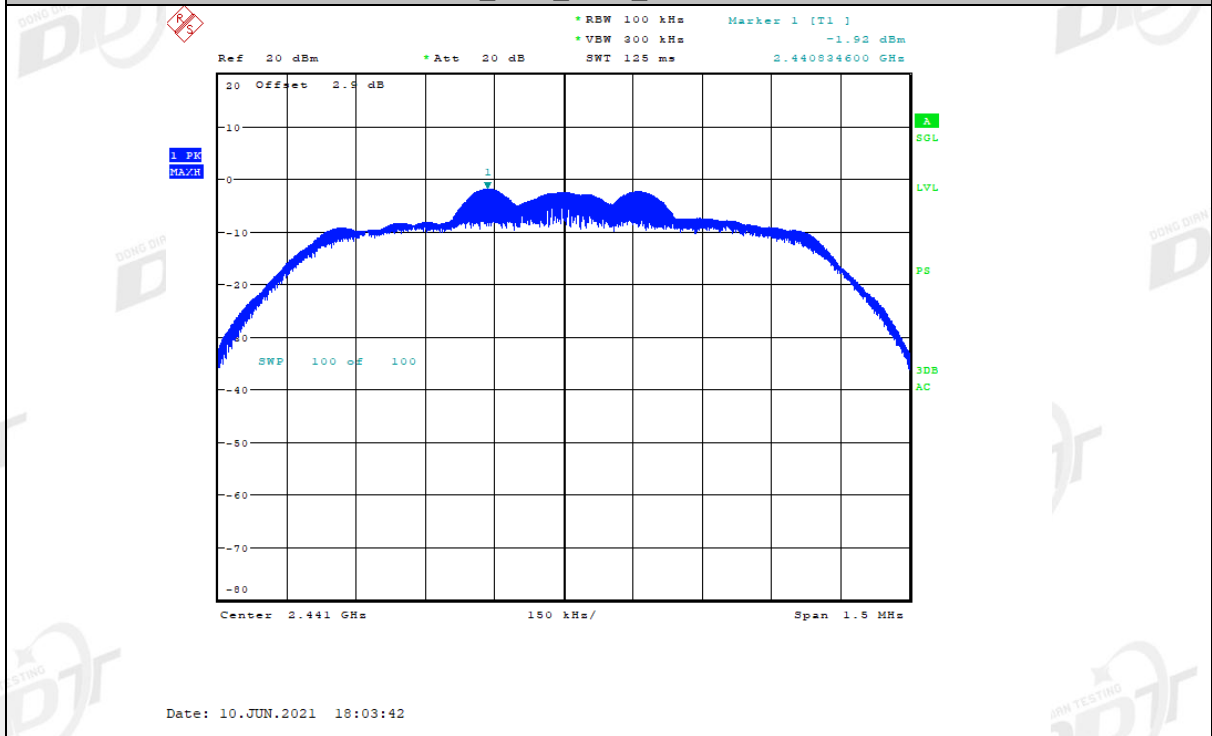

2DH5\_Ant1\_2441\_30~26500

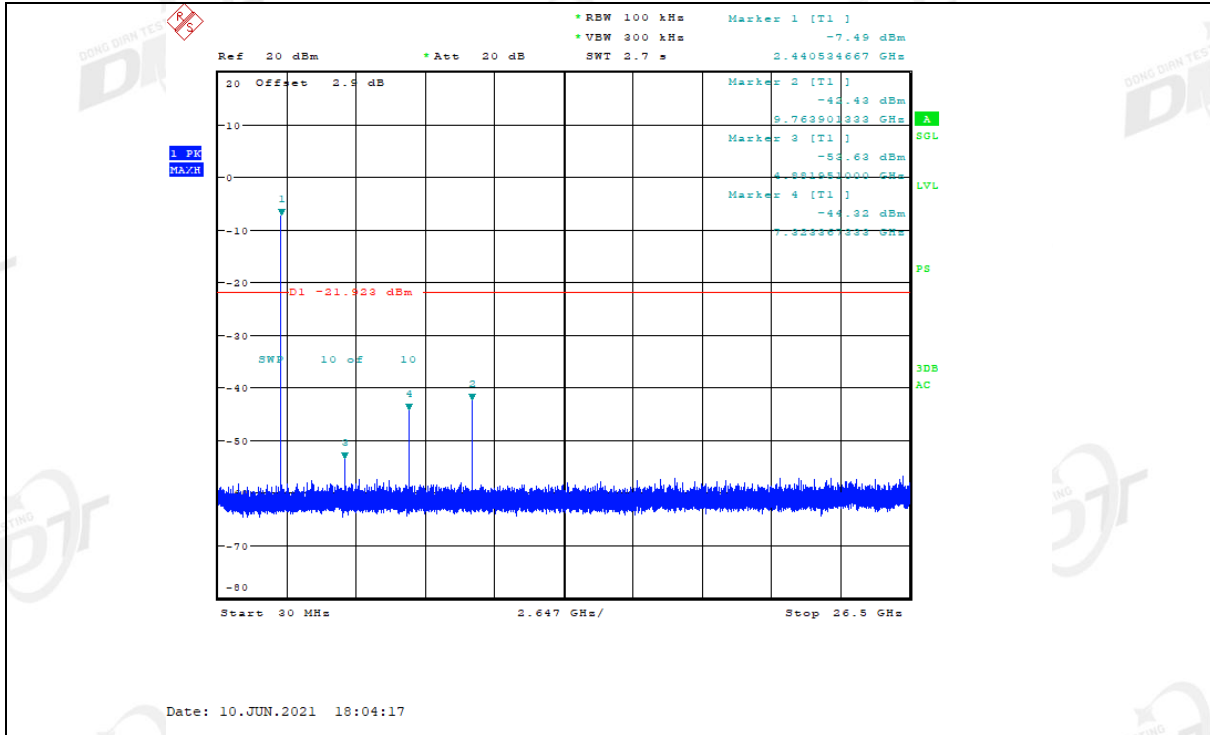

2DH5\_Ant1\_2480\_0-Reference

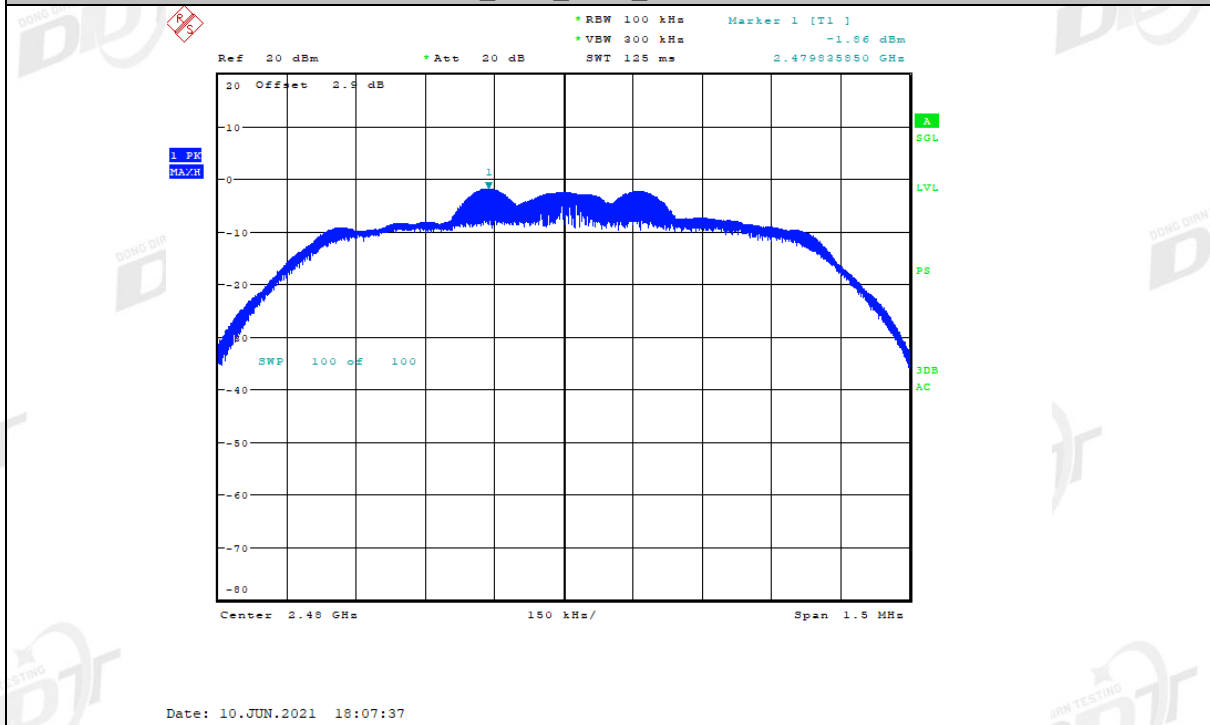

2DH5\_Ant1\_2480\_30~26500

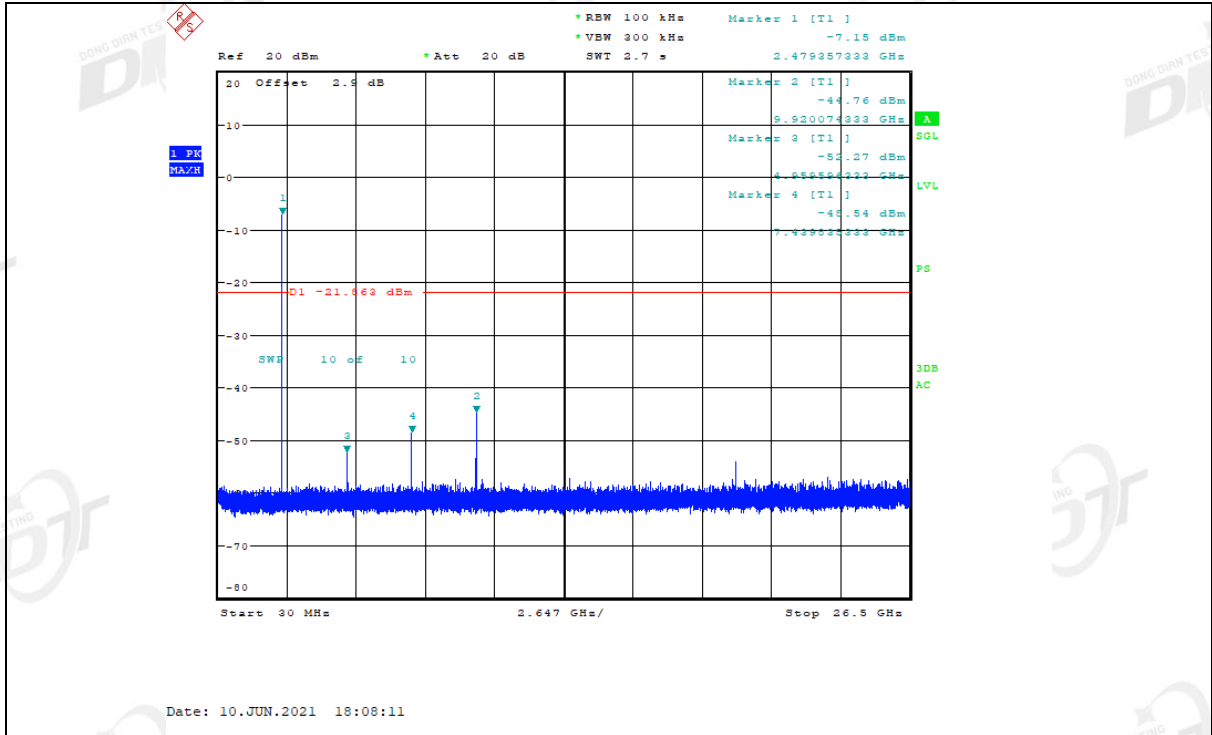

3DH5\_Ant1\_2402\_0-Reference

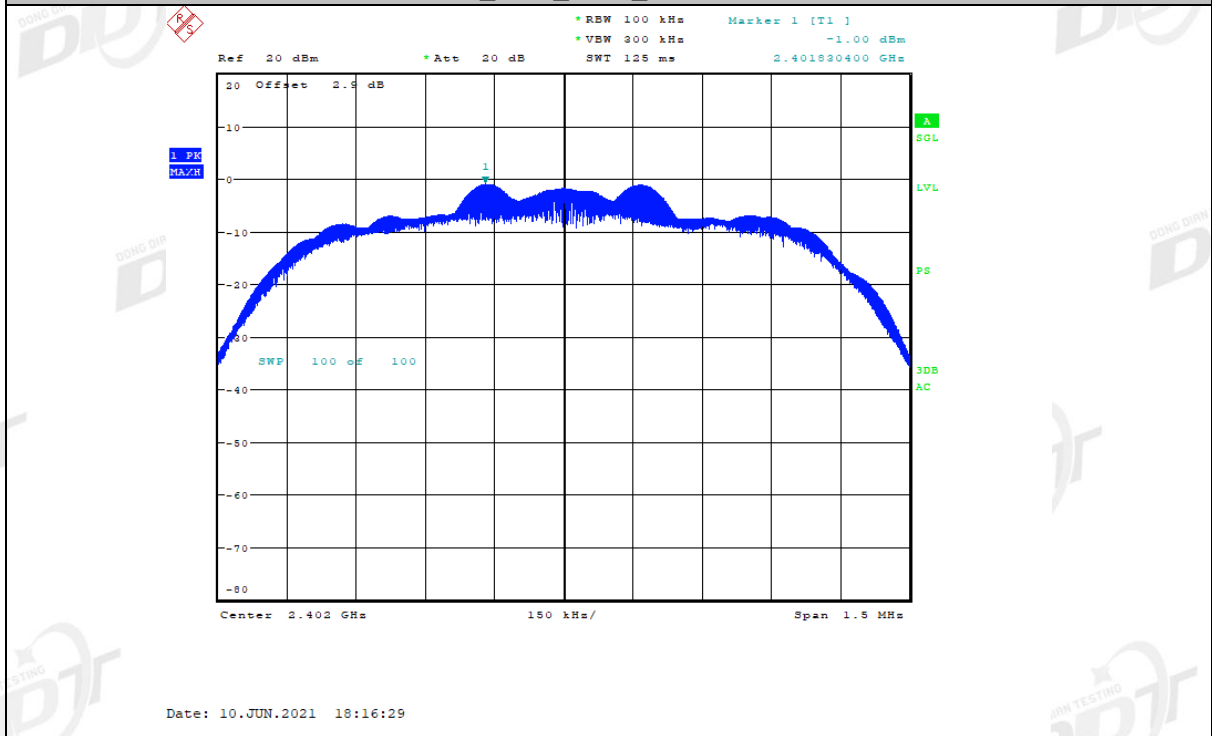

3DH5\_Ant1\_2402\_30~26500



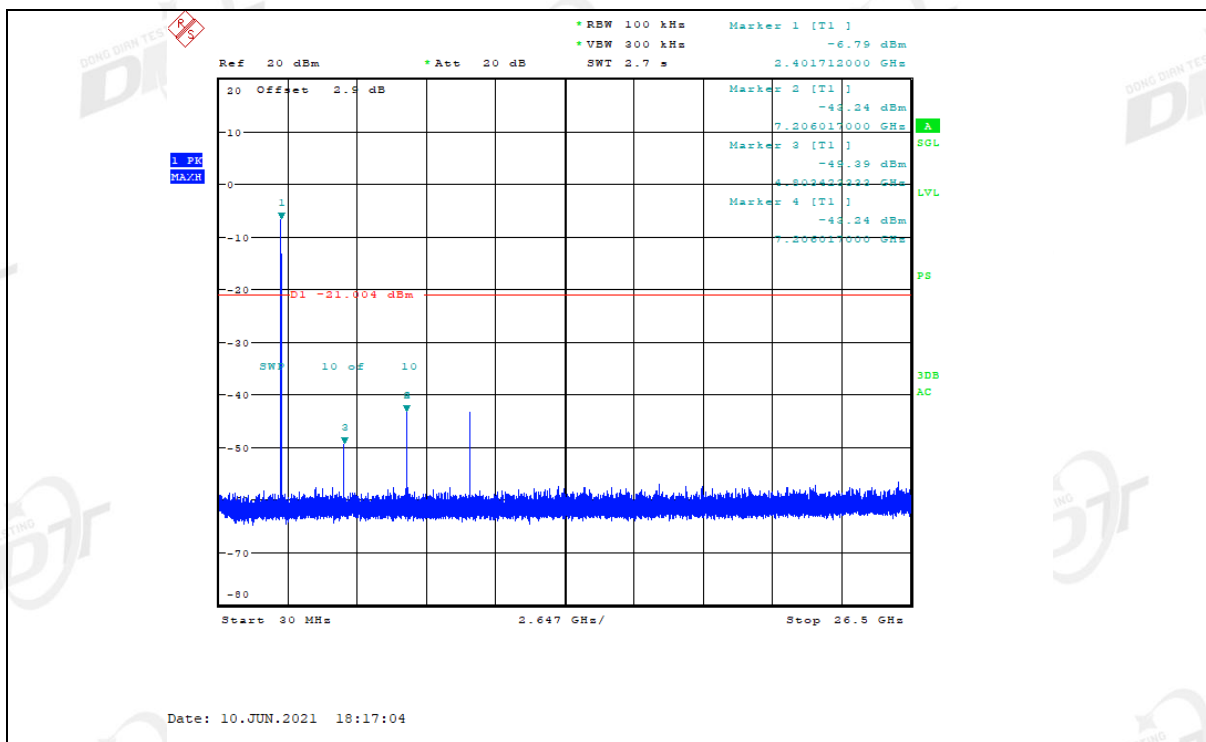

3DH5\_Ant1\_2441\_0-Reference

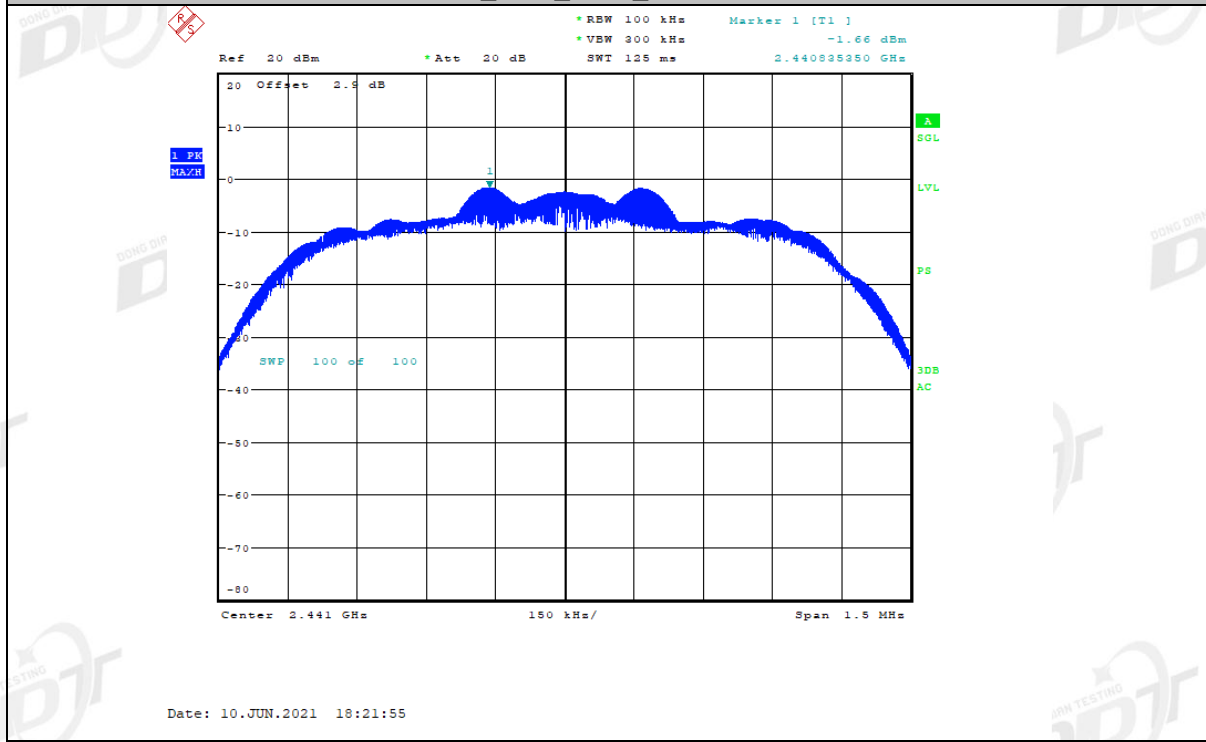

3DH5\_Ant1\_2441\_30~26500

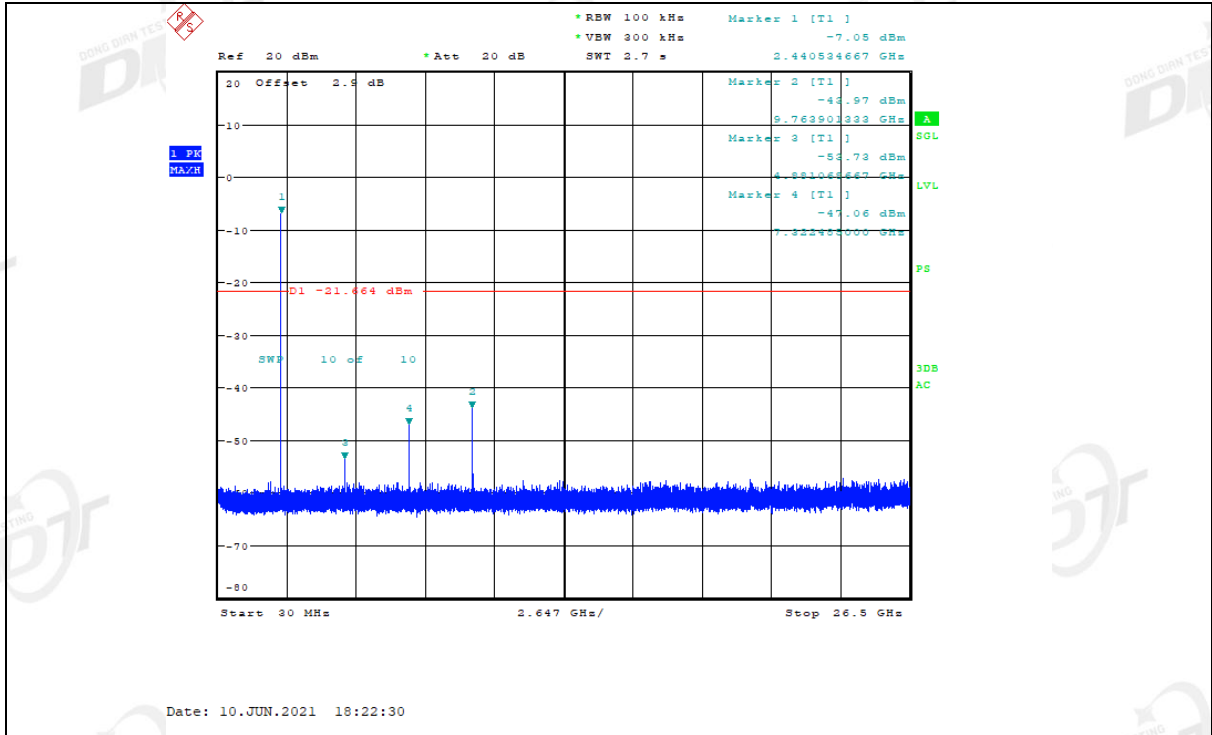

3DH5\_Ant1\_2480\_0-Reference

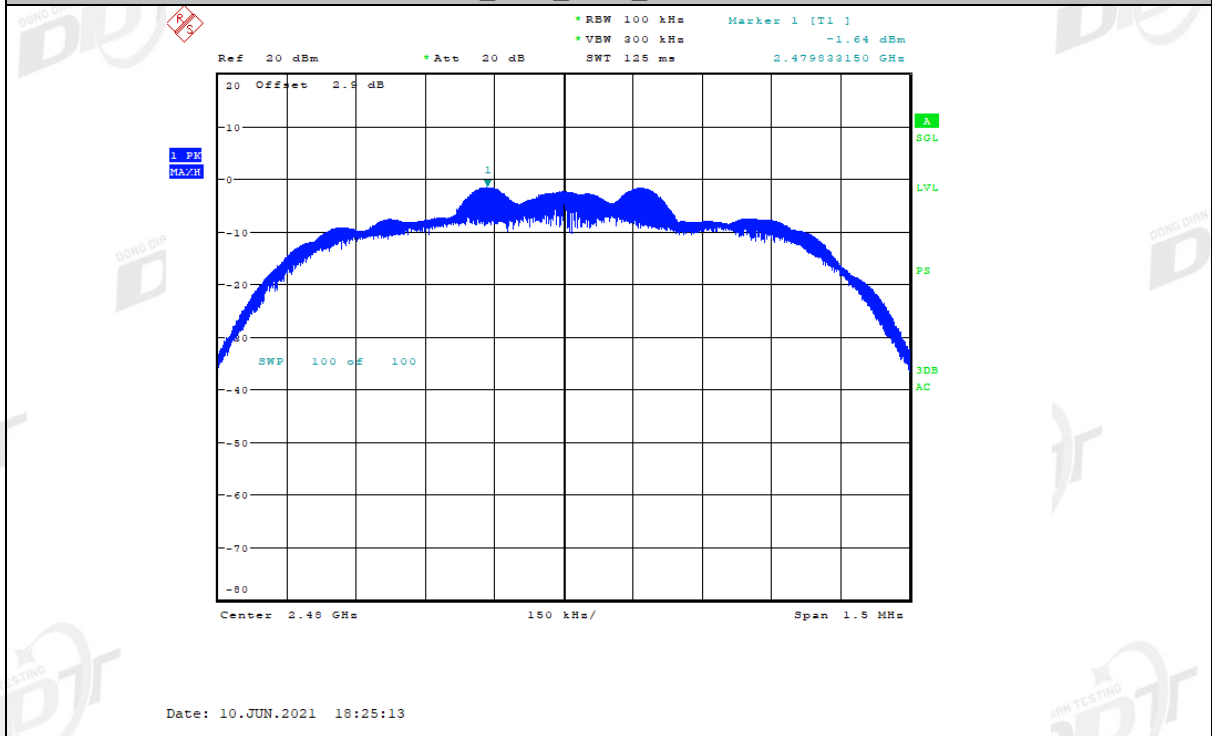

3DH5\_Ant1\_2480\_30~26500

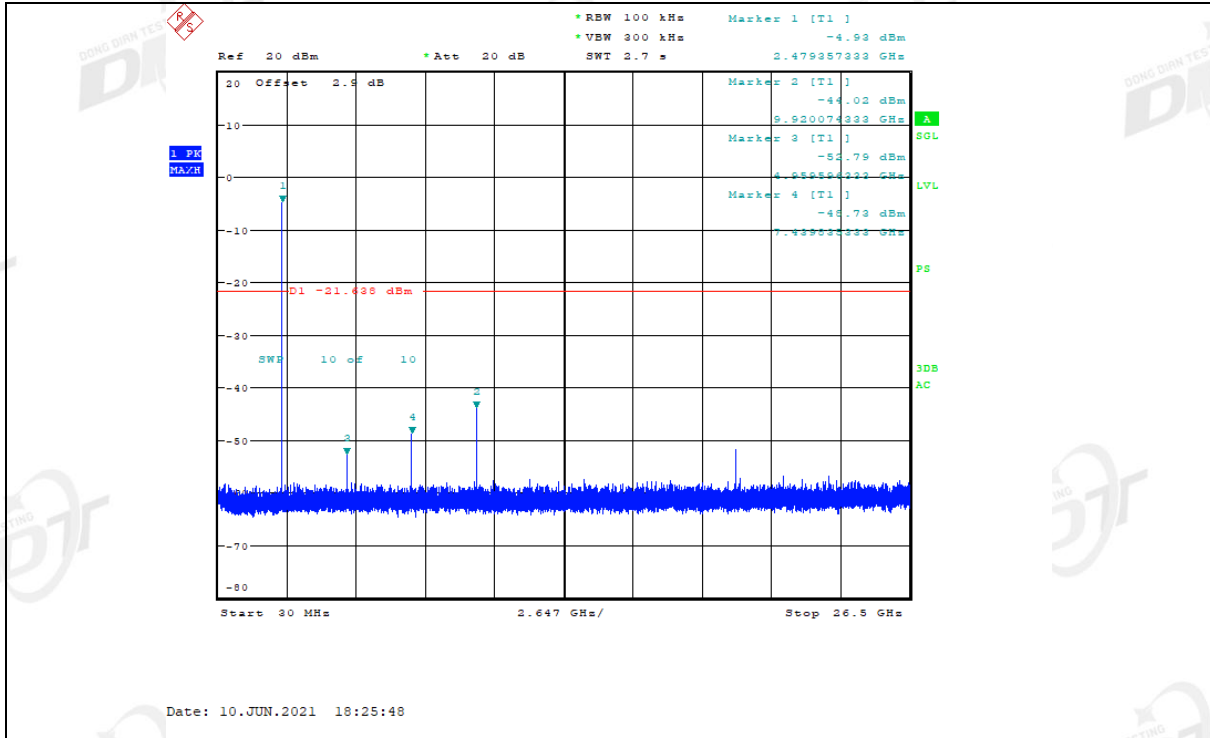

Right side:

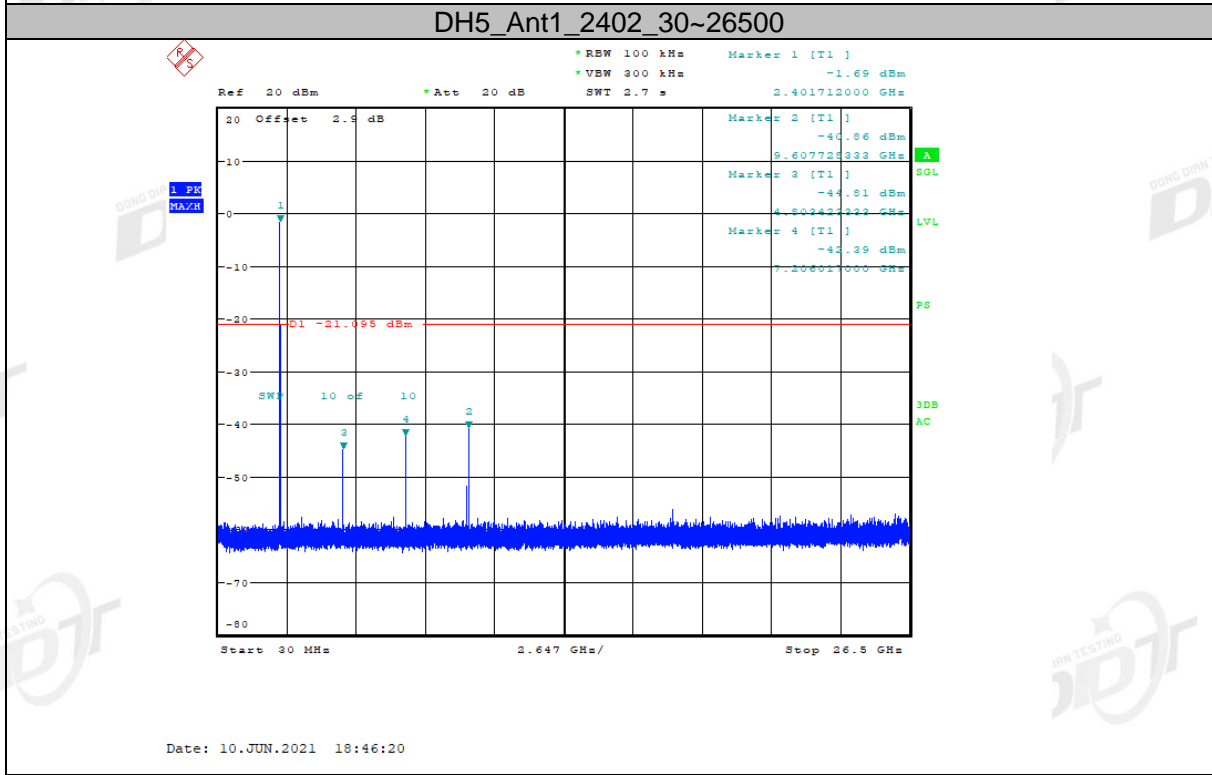
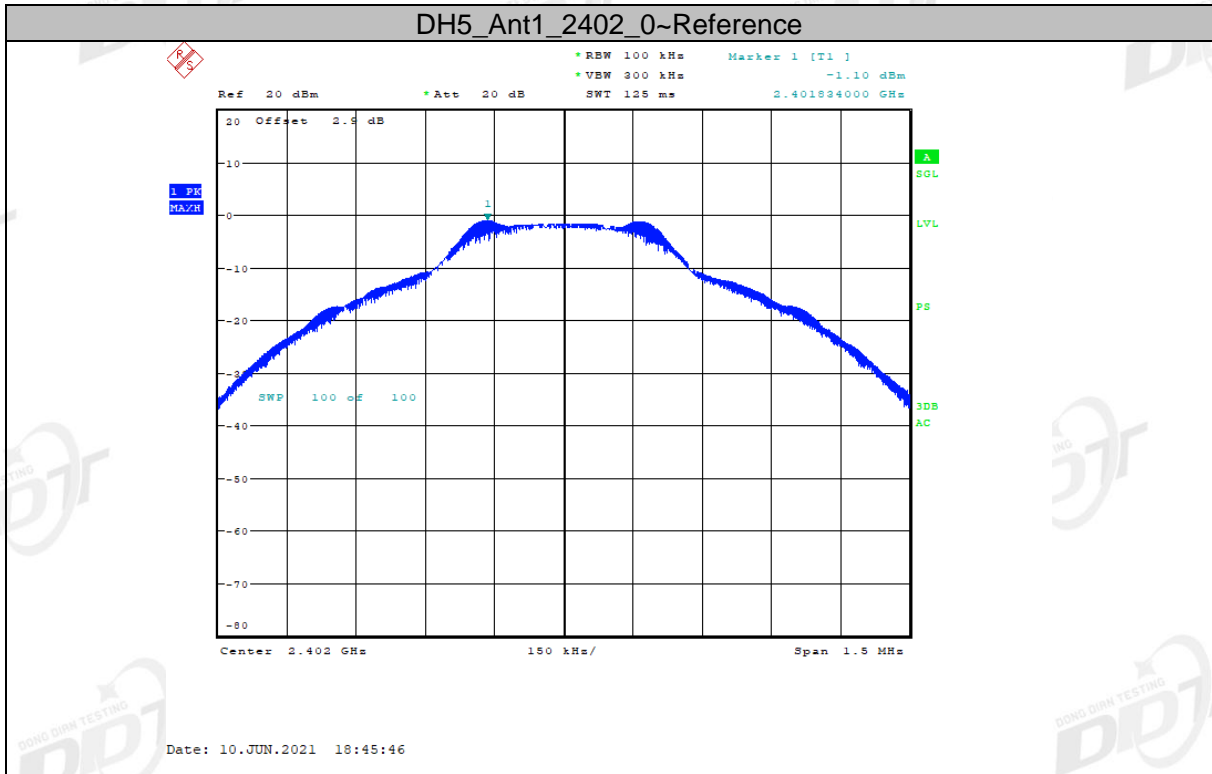

### DH5\_Ant1\_2441\_0~Reference

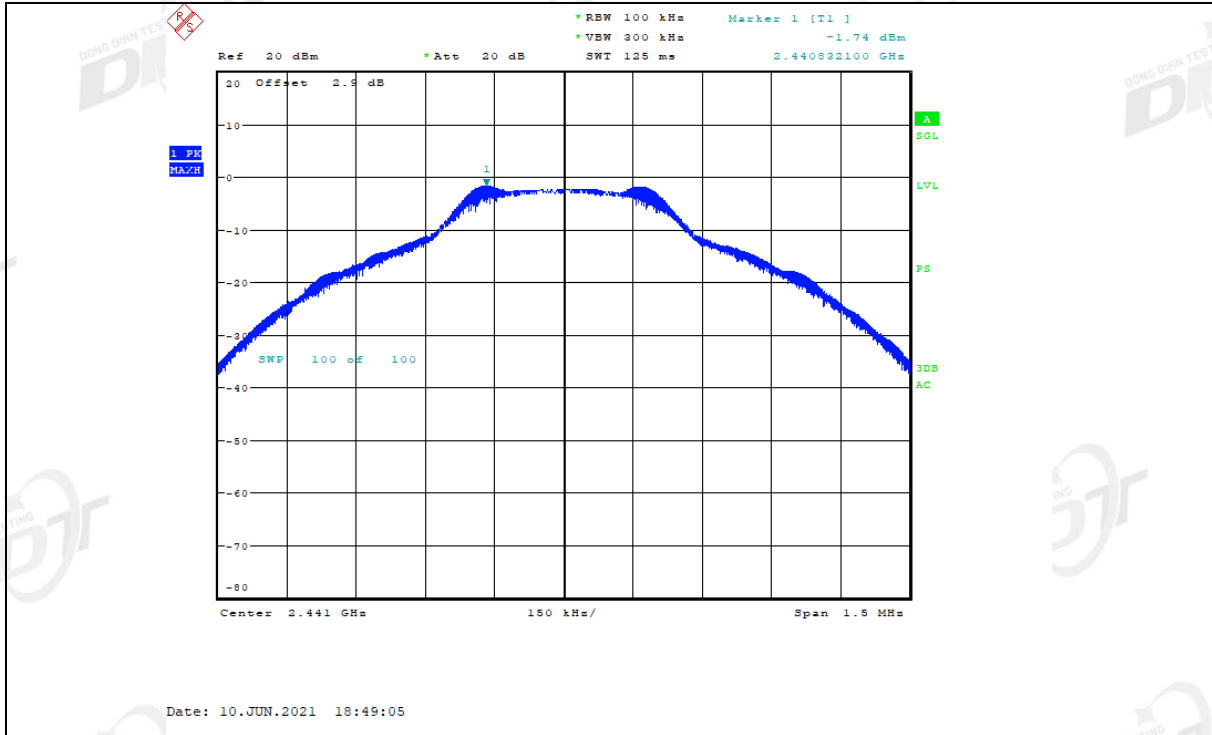

DH5\_Ant1\_2441\_30~26500

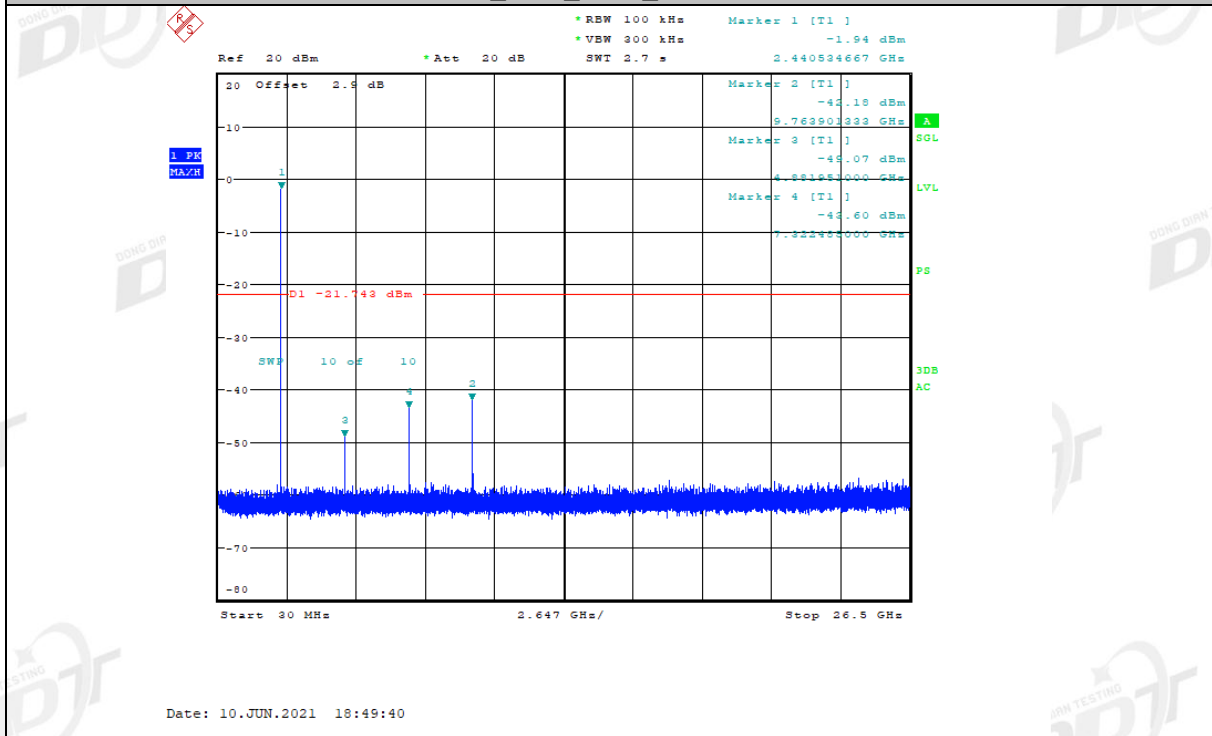

DH5\_Ant1\_2480\_0~Reference

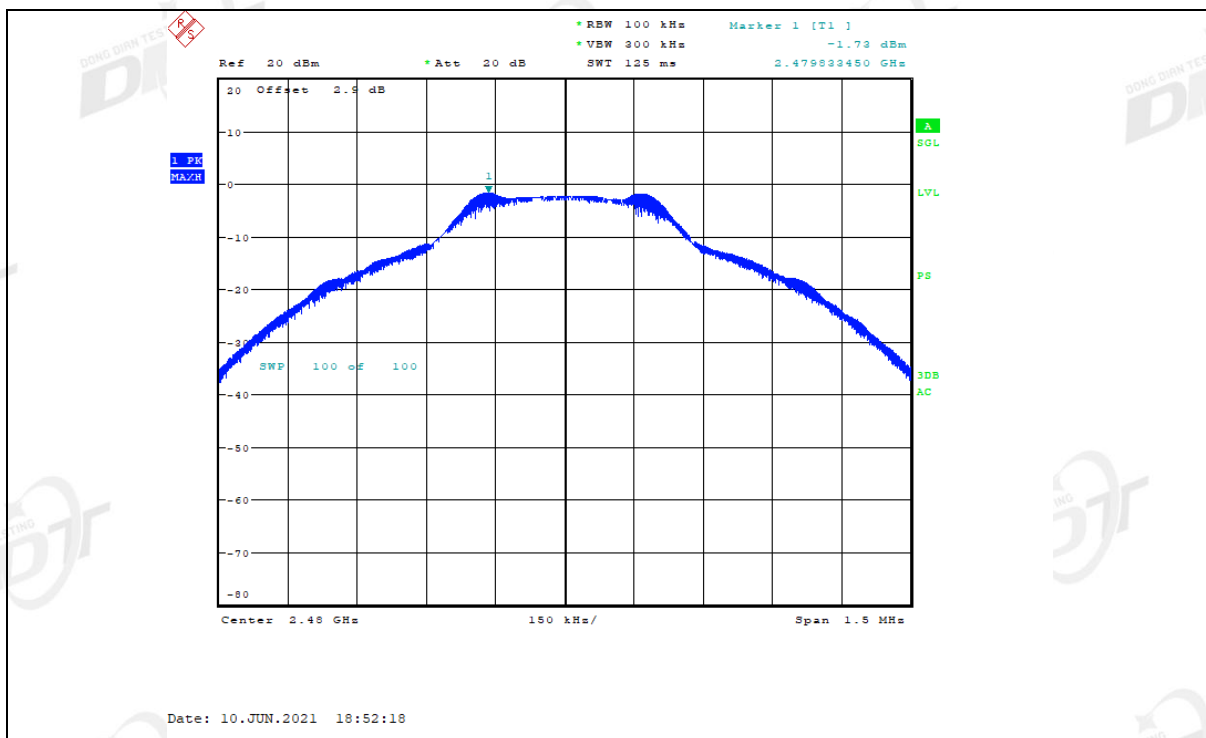

DH5\_Ant1\_2480\_30~26500

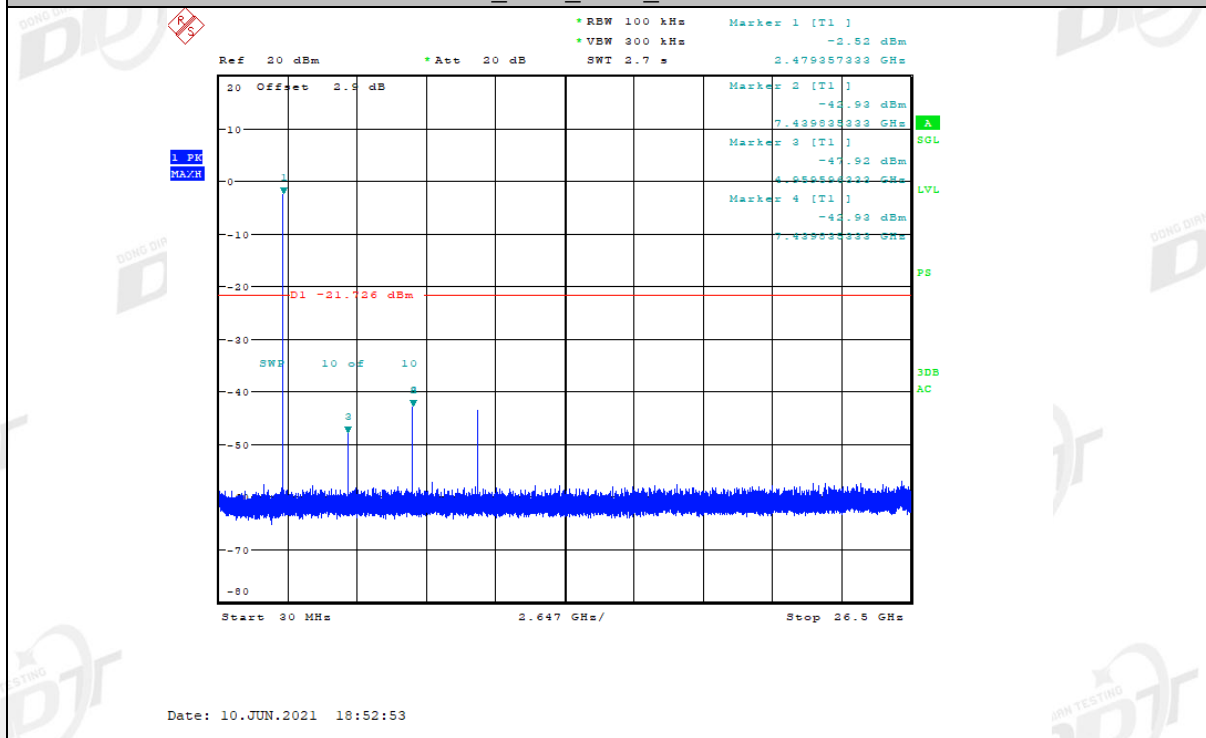

2DH5\_Ant1\_2402\_0~Reference

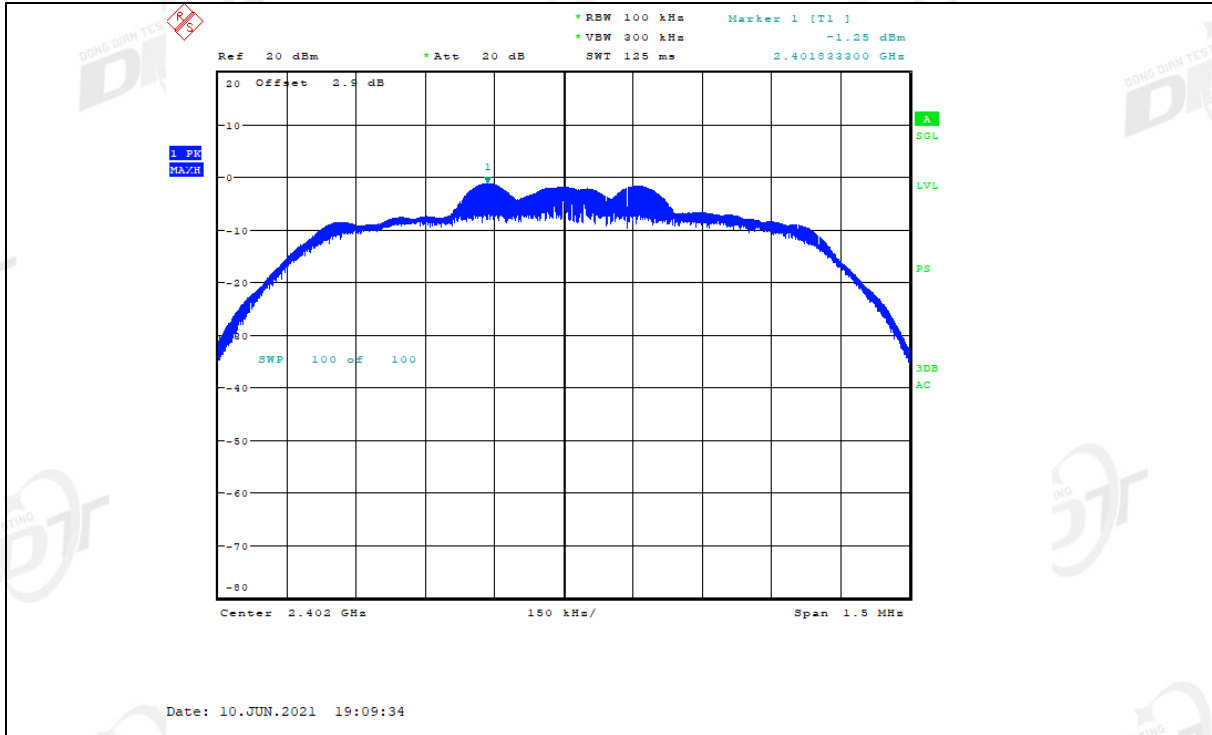

2DH5\_Ant1\_2402\_30~26500

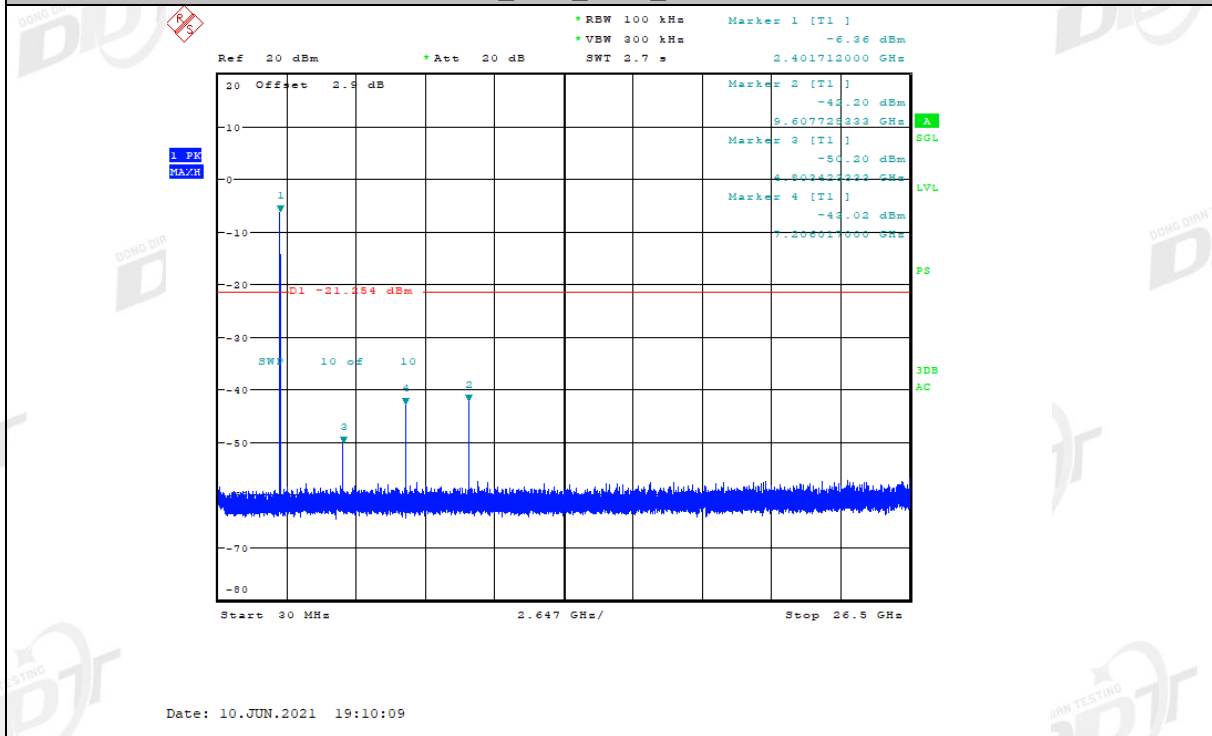

2DH5\_Ant1\_2441\_0~Reference

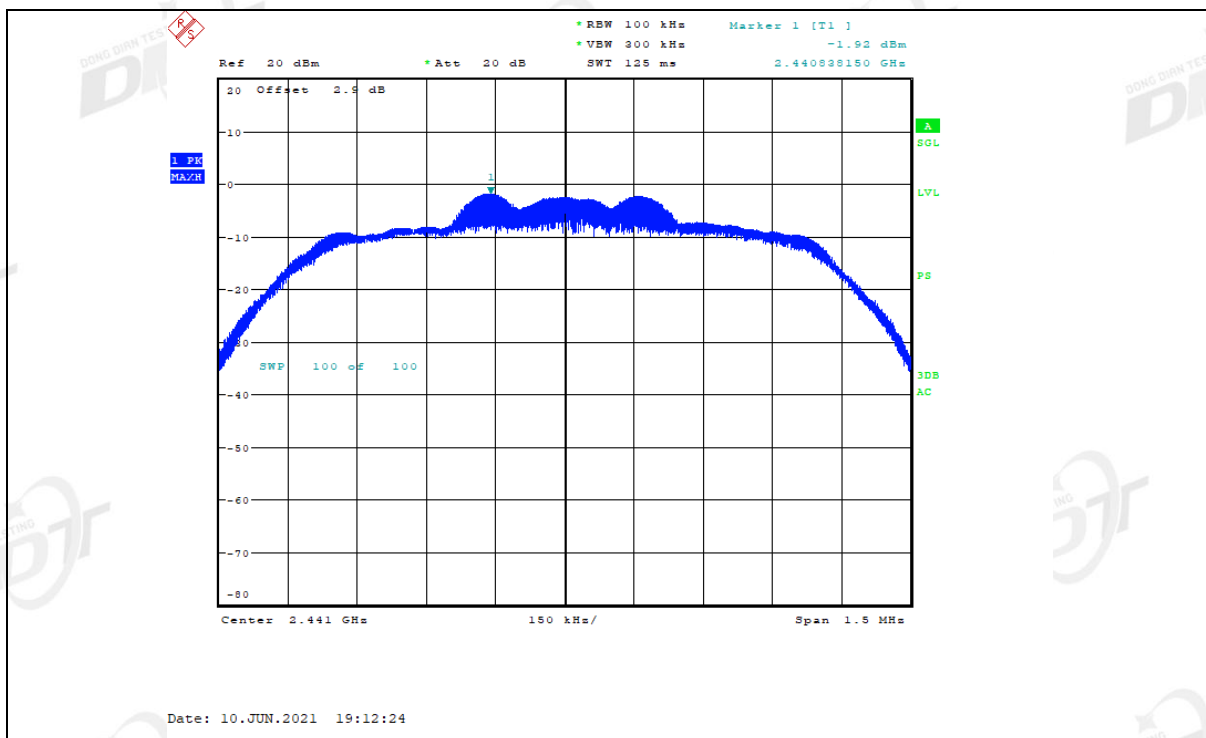

2DH5\_Ant1\_2441\_30~26500

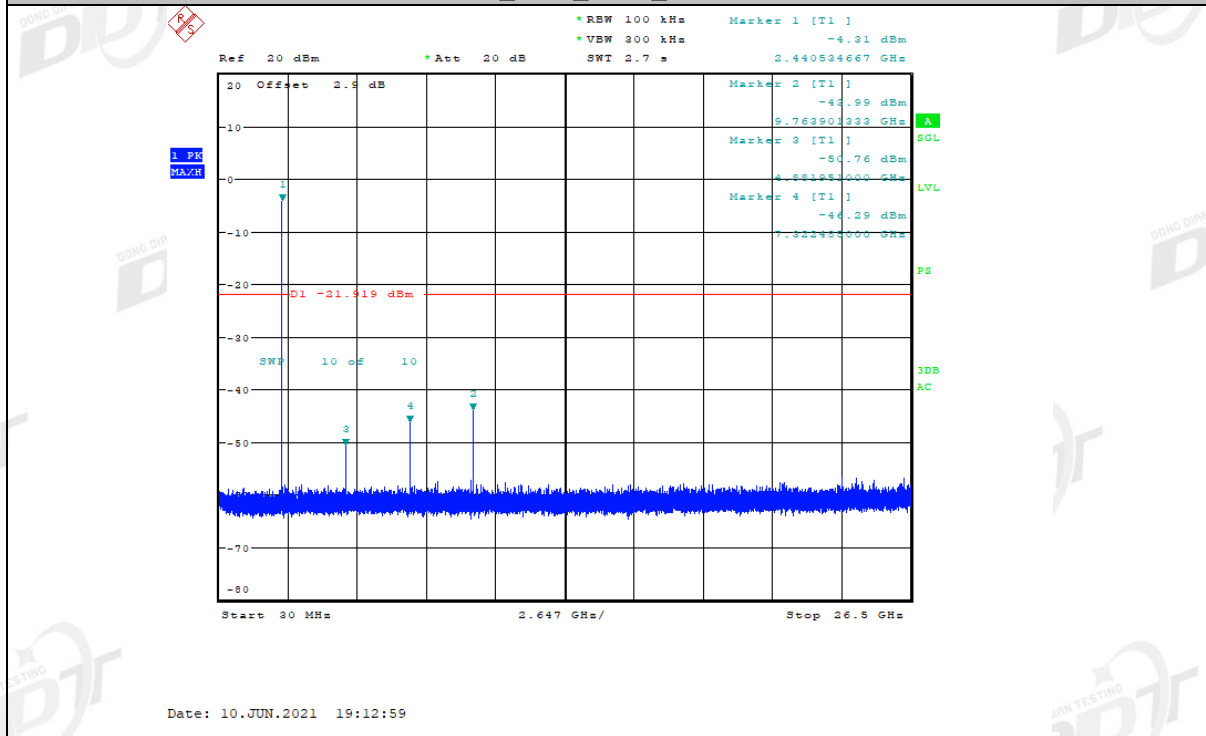

2DH5\_Ant1\_2480\_0-Reference



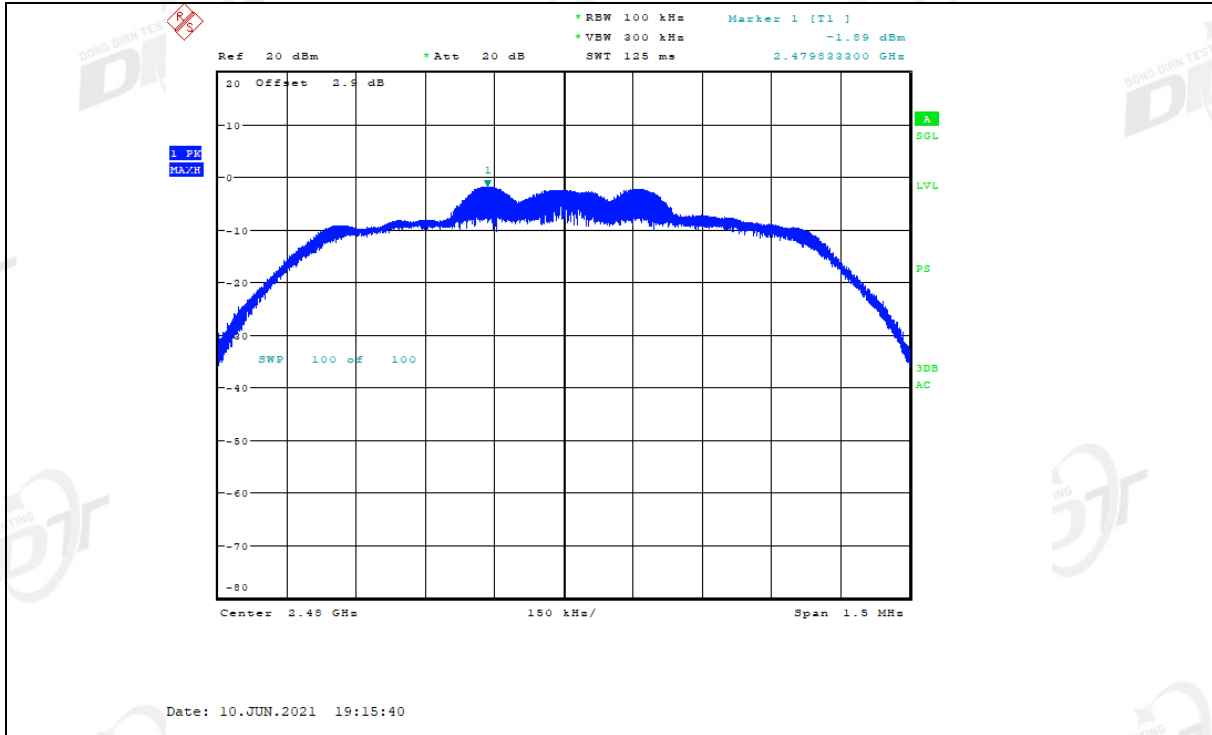

2DH5\_Ant1\_2480\_30~26500

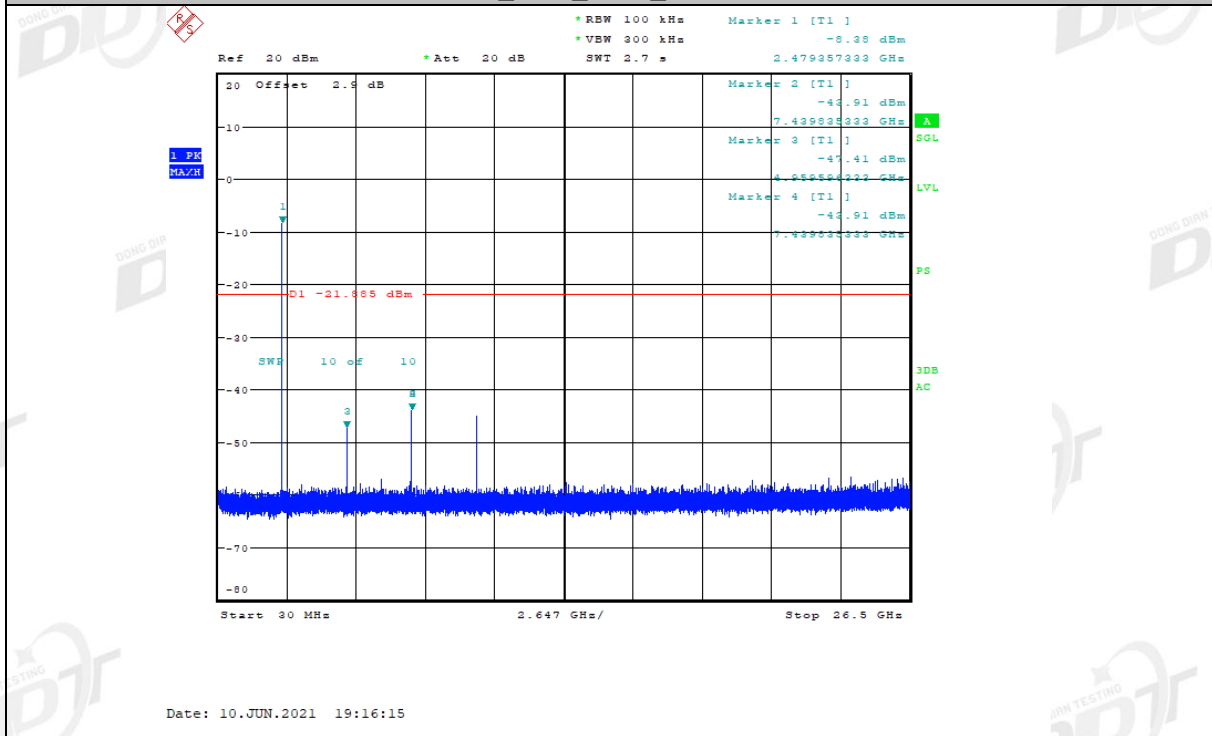

3DH5\_Ant1\_2402\_0-Reference

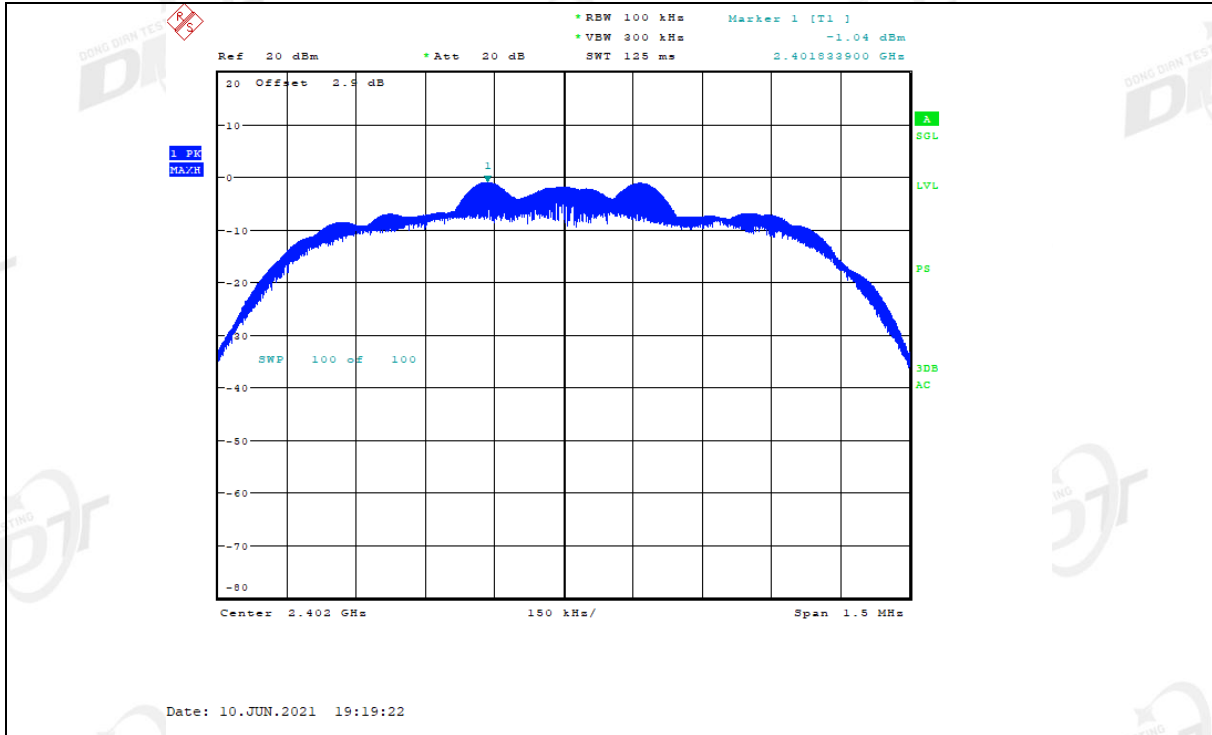

3DH5\_Ant1\_2402\_30~26500

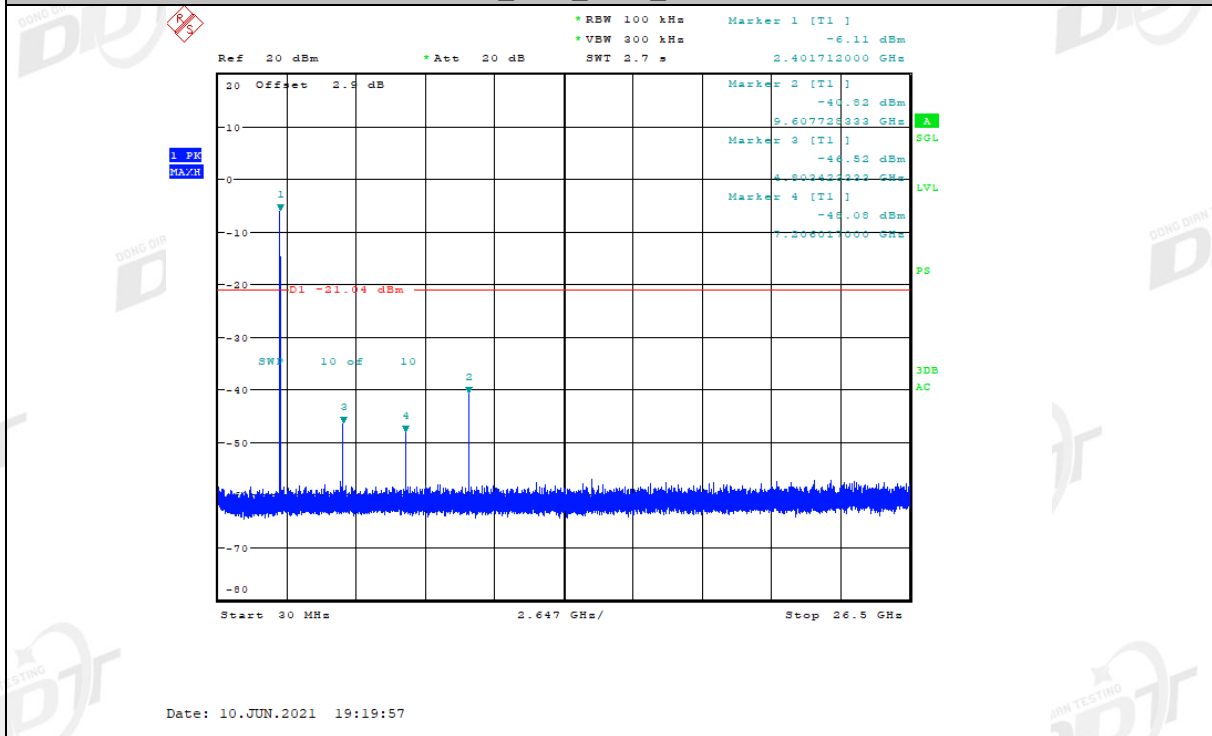

3DH5\_Ant1\_2441\_0-Reference

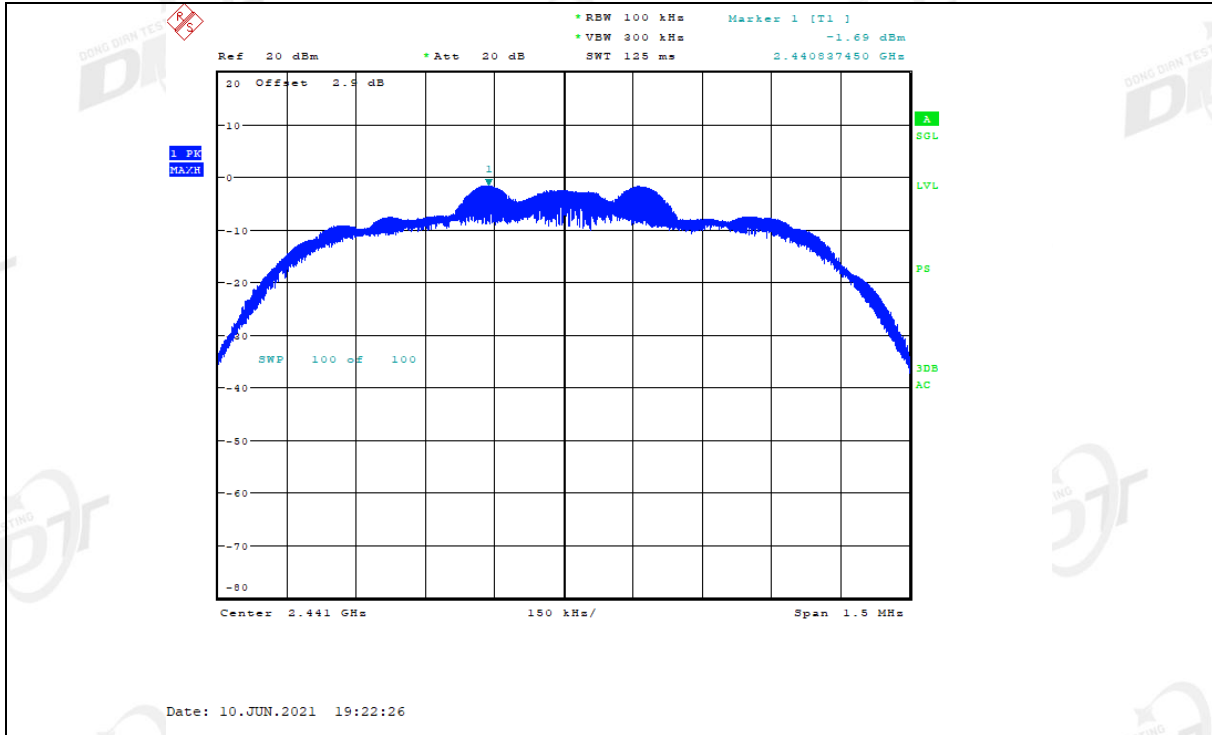

3DH5\_Ant1\_2441\_30~26500

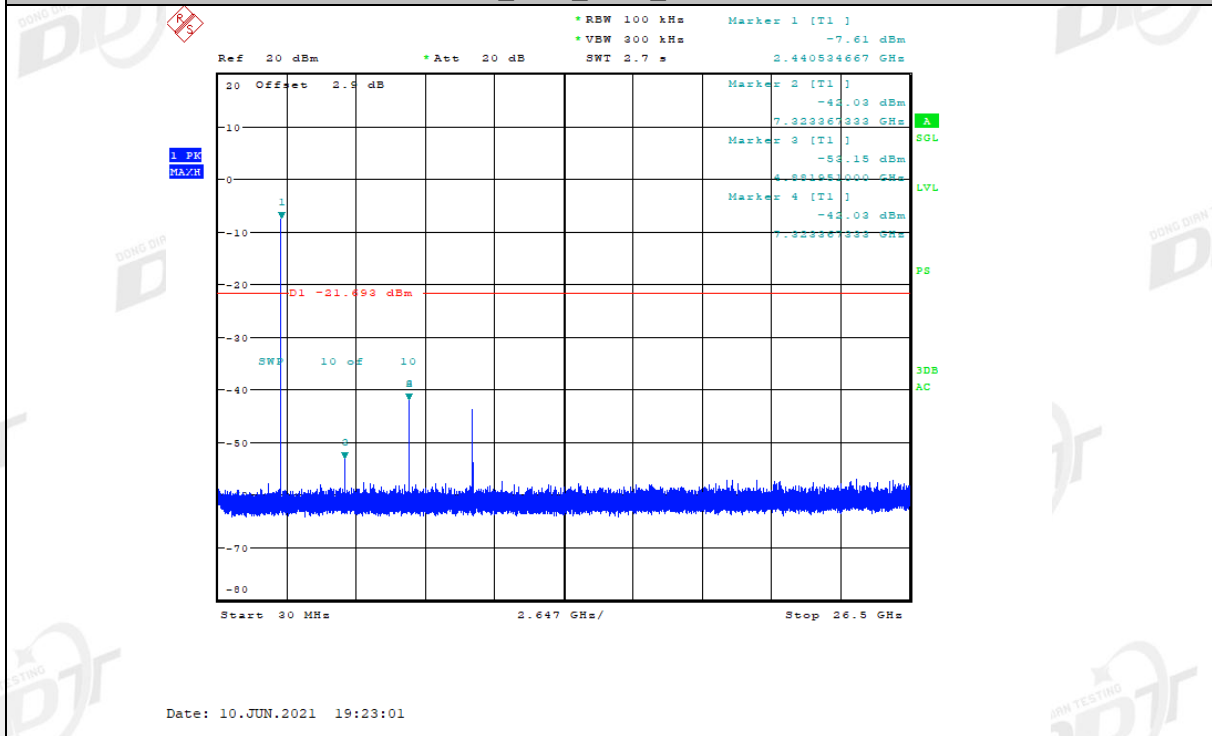

3DH5\_Ant1\_2480\_0-Reference

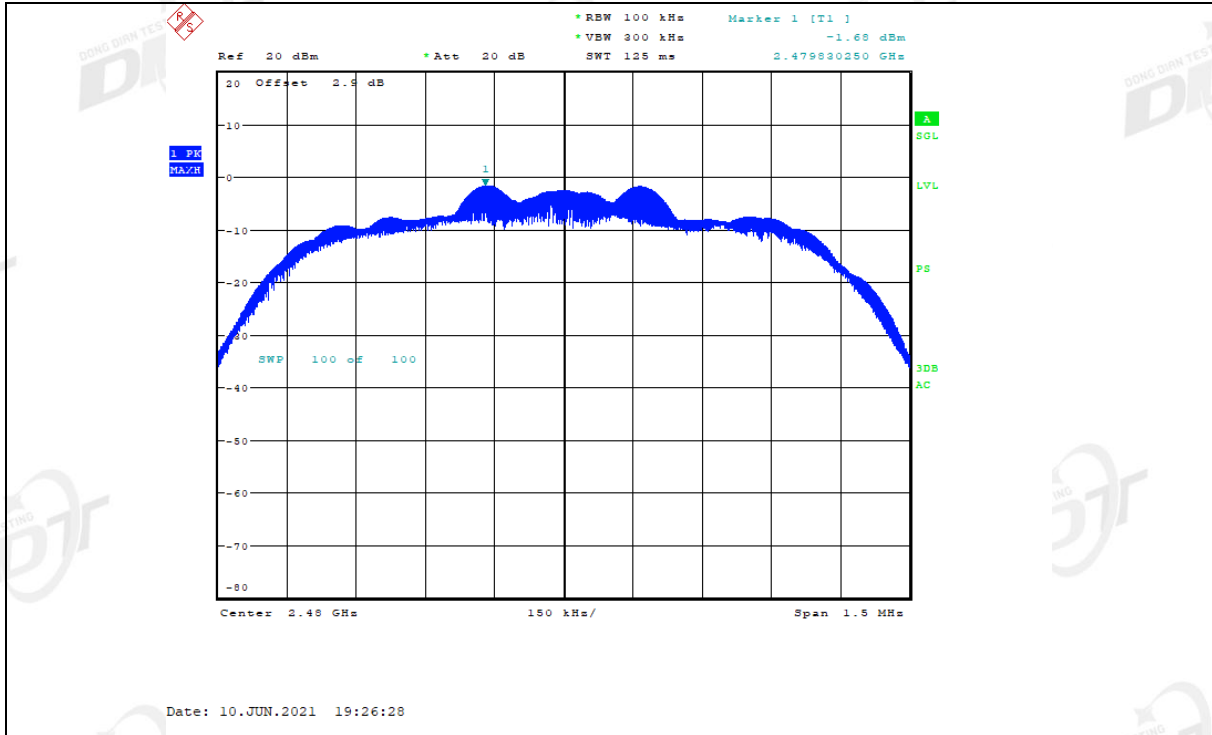

3DH5\_Ant1\_2480\_30~26500

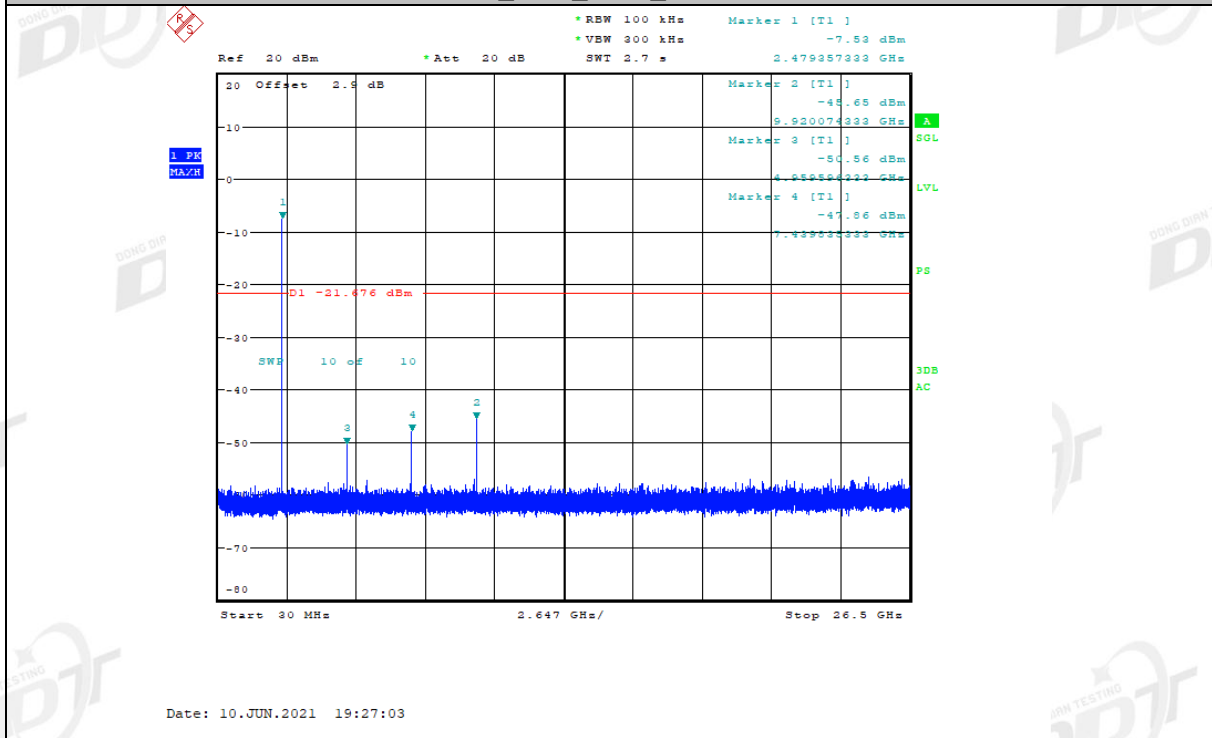

## 12. Band Edge Compliance (Radiated Method)

### 12.1. Block diagram of test setup

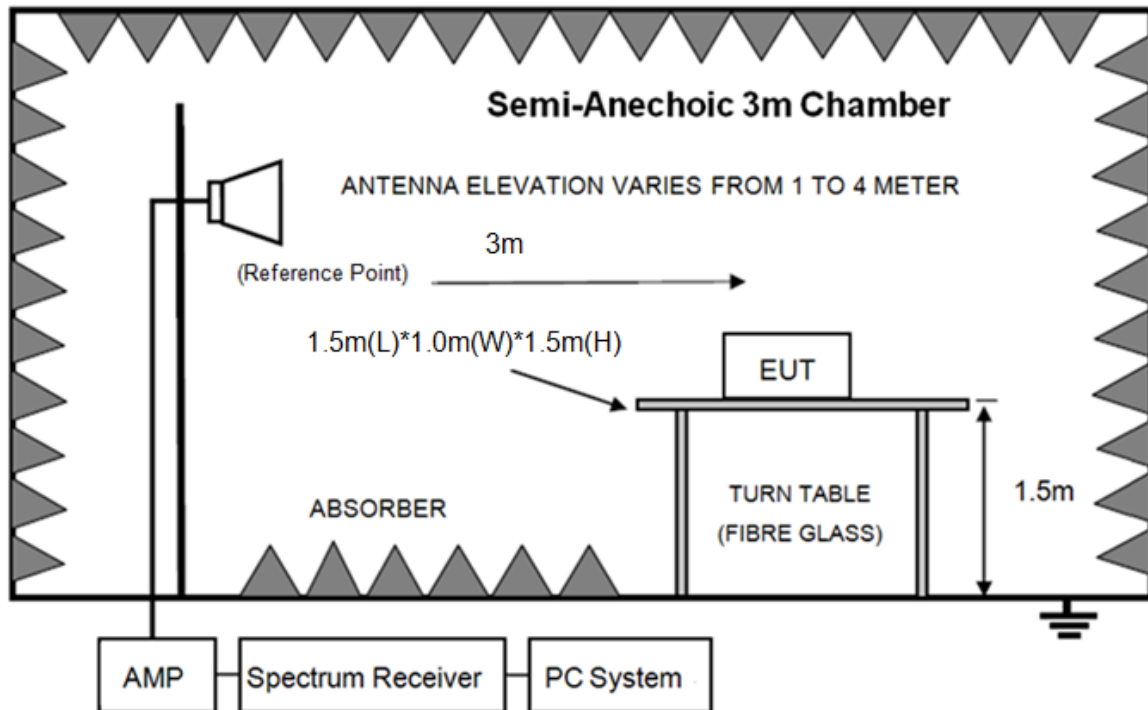

### 12.2. Limit

All restriction band should comply with 15.209, other emission should be at least 20 dB below the fundamental.

### 12.3. Test Procedure

Same with clause 10.3 except change investigated frequency range from 2310 MHz to 2410 MHz and 2470 MHz to 2550 MHz.

Remark: All restriction band have been tested, and only the worst case is shown in report.

### 12.4. Test result

Pass. (See below detailed test result)

Remark: hopping on and hopping off mode all have been test, hopping off mode is worse and reported only.

## TR-4-E-009 Radiated Emission Test Result

**Test Site** : DDT 3m Chamber 2#

E:\E3\_Report\TestData\Q21051406-1E Du smart buds\RF.EM6

**Test Date** : 05-26-2021

**Tested By** : Ella

**EUT** : Du smart buds

**Model Number** : XD-SWA14-2101

**Power Supply** : Battery

**Test Mode** : Tx mode

**Condition** : Temp:24.5°C,Humi:55%,Press:100.1kPa

**Antenna/Distance** : 2021 BBHA9120D/3m/HORIZONTAL

**Memo** : Right DH5 2402MHz

Data: 1

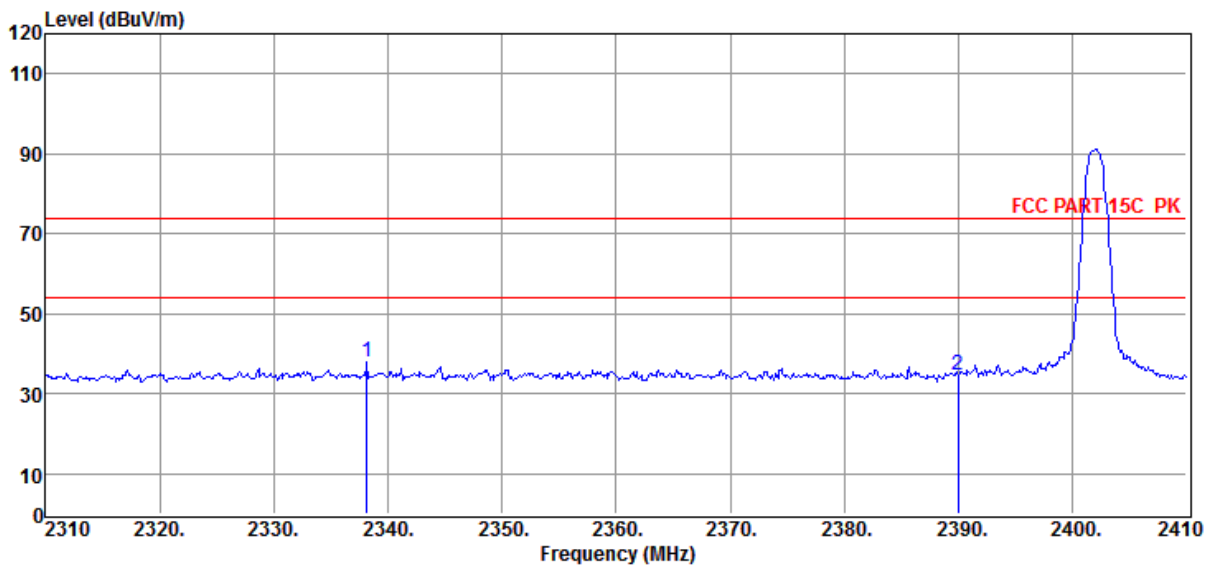

Item (Mark)	Freq. (MHz)	Read Level (dBuV)	Antenna Factor (dB/m)	PRM Factor (dB)	Cable Loss (dB)	Result Level (dBuV/m)	Limit Line (dBuV/m)	Over Limit (dB)	Detector	Polarization
1	2338.20	43.75	28.13	0.00	-33.96	37.92	74.00	-36.08	Peak	HORIZONTAL
2	2390.00	40.57	28.05	0.00	-34.02	34.60	74.00	-39.40	Peak	HORIZONTAL

Note: 1. Result Level = Read Level + Antenna Factor + Cable loss - PRM Factor.

2. If Peak Result complies with AV limit, AV Result is deemed to comply with AV limit.

3. Test setup: RBW: 1 MHz, VBW: 3 MHz, Sweep time: auto.

# TR-4-E-009 Radiated Emission Test Result

**Test Site** : DDT 3m Chamber 2# **E:\E3\_Report\TestData\Q21051406-1E Du smart buds\RF.EM6**  
**Test Date** : 05-26-2021 **Tested By** : Ella  
**EUT** : Du smart buds **Model Number** : XD-SWA14-2101  
**Power Supply** : Battery **Test Mode** : Tx mode  
**Condition** : Temp:24.5°C,Humi:55%,Press:100.1kPa **Antenna/Distance** : 2021 BBHA9120D/3m/VERTICAL  
**Memo** : Right DH5 2402MHz

Data: 2

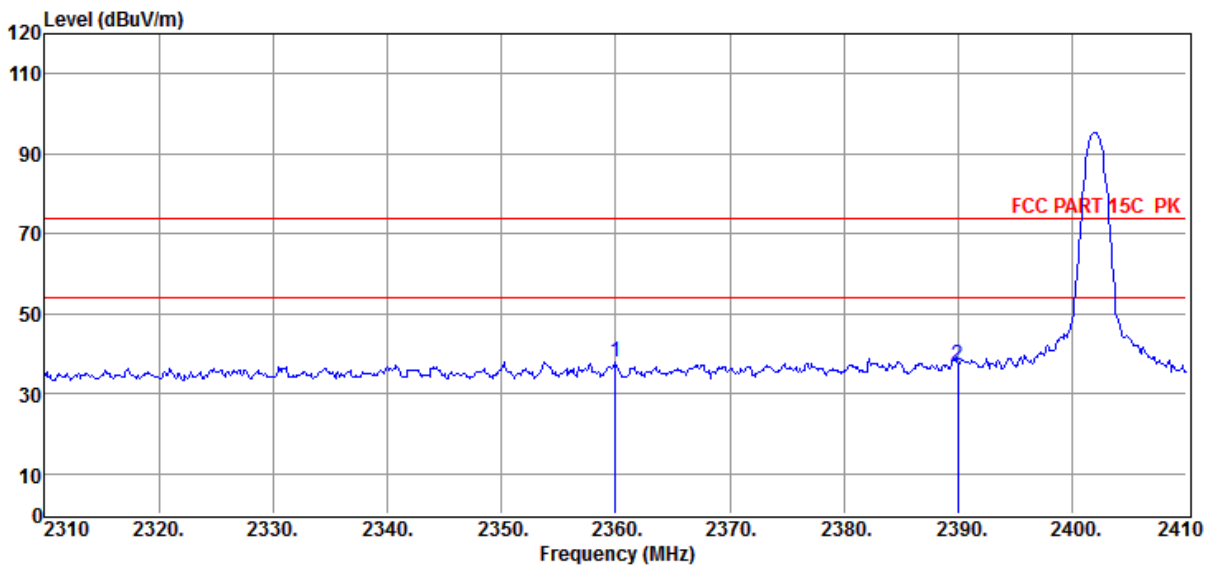

Item (Mark)	Freq. (MHz)	Read Level (dBμV)	Antenna Factor (dB/m)	PRM Factor (dB)	Cable Loss (dB)	Result Level (dBμV/m)	Limit Line (dBμV/m)	Over Limit (dB)	Detector	Polarization
1	2360.00	43.98	28.10	0.00	-33.98	38.10	74.00	-35.90	Peak	VERTICAL
2	2390.00	43.25	28.05	0.00	-34.02	37.28	74.00	-36.72	Peak	VERTICAL

- Note: 1. Result Level = Read Level + Antenna Factor + Cable loss - PRM Factor.  
 2. If Peak Result complies with AV limit, AV Result is deemed to comply with AV limit.  
 3. Test setup: RBW: 1 MHz, VBW: 3 MHz, Sweep time: auto.

# TR-4-E-009 Radiated Emission Test Result

**Test Site** : DDT 3m Chamber 2# **E:\E3\_Report\TestData\Q21051406-1E Du smart buds\RF.EM6**  
**Test Date** : 05-26-2021 **Tested By** : Ella  
**EUT** : Du smart buds **Model Number** : XD-SWA14-2101  
**Power Supply** : Battery **Test Mode** : Tx mode  
**Condition** : Temp:24.5°C,Humi:55%,Press:100.1kPa **Antenna/Distance** : 2021 BBHA9120D/3m/VERTICAL  
**Memo** : Right DH5 2480MHz

Data: 3

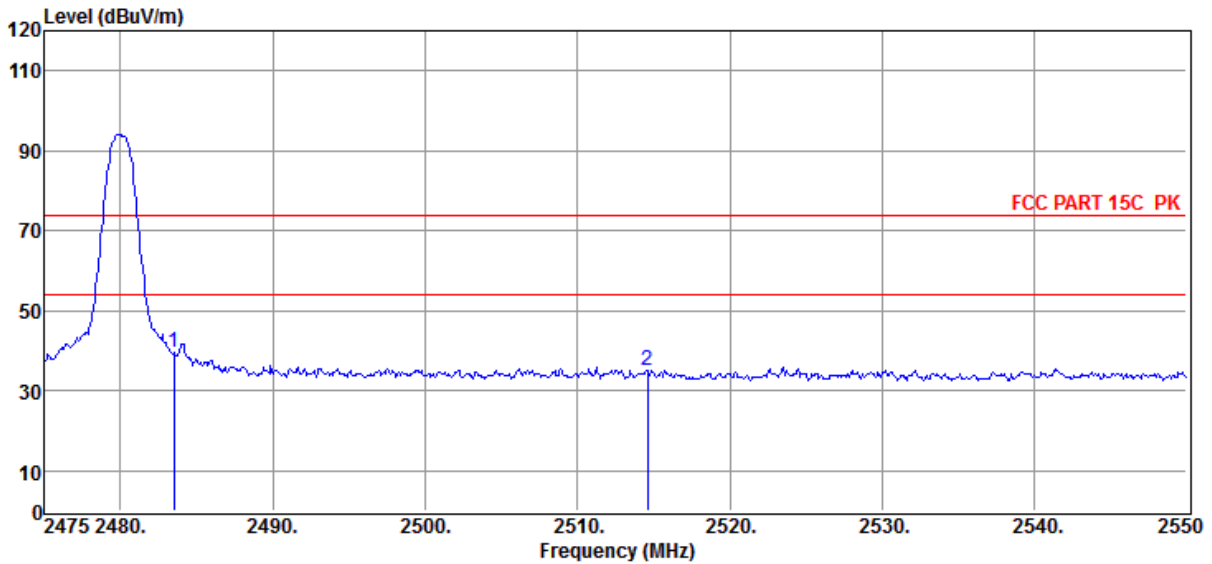

Item (Mark)	Freq. (MHz)	Read Level (dBμV)	Antenna Factor (dB/m)	PRM Factor (dB)	Cable Loss (dB)	Result Level (dBμV/m)	Limit Line (dBμV/m)	Over Limit (dB)	Detector	Polarization
1	2483.50	45.55	27.92	0.00	-33.79	39.68	74.00	-34.32	Peak	VERTICAL
2	2514.60	40.83	27.94	0.00	-33.53	35.24	74.00	-38.76	Peak	VERTICAL

- Note: 1. Result Level = Read Level + Antenna Factor + Cable loss - PRM Factor.  
 2. If Peak Result complies with AV limit, AV Result is deemed to comply with AV limit.  
 3. Test setup: RBW: 1 MHz, VBW: 3 MHz, Sweep time: auto.



## TR-4-E-009 Radiated Emission Test Result

**Test Site** : DDT 3m Chamber 2#

E:\E3\_Report\TestData\Q21051406-1E Du smart buds\RF.EM6

**Test Date** : 05-26-2021

**Tested By** : Ella

**EUT** : Du smart buds

**Model Number** : XD-SWA14-2101

**Power Supply** : Battery

**Test Mode** : Tx mode

**Condition** : Temp:24.5°C,Humi:55%,Press:100.1kPa

**Antenna/Distance** : 2021 BBHA9120D/3m/HORIZONTAL

**Memo** : Right DH5 2480MHz

Data: 4

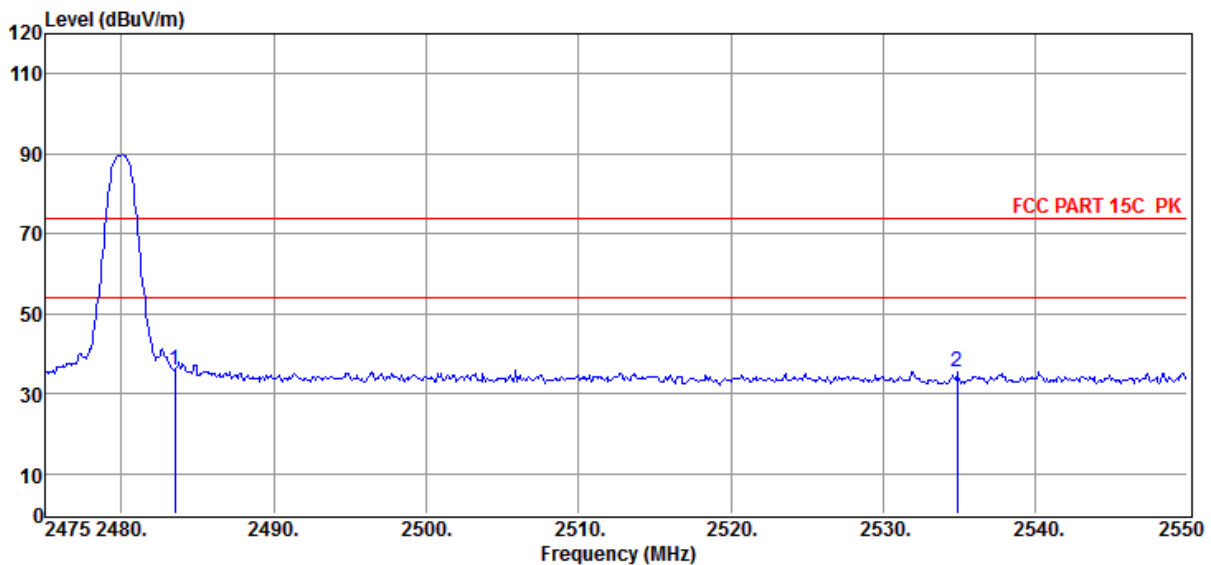

Item (Mark)	Freq. (MHz)	Read Level (dBuV)	Antenna Factor (dB/m)	PRM Factor (dB)	Cable Loss (dB)	Result Level (dBuV/m)	Limit Line (dBuV/m)	Over Limit (dB)	Detector	Polarization
1	2483.50	41.82	27.92	0.00	-33.79	35.95	74.00	-38.05	Peak	HORIZONTAL
2	2534.85	40.99	27.99	0.00	-33.54	35.44	74.00	-38.56	Peak	HORIZONTAL

Note: 1. Result Level = Read Level + Antenna Factor + Cable loss - PRM Factor.

2. If Peak Result complies with AV limit, AV Result is deemed to comply with AV limit.

3. Test setup: RBW: 1 MHz, VBW: 3 MHz, Sweep time: auto.

## TR-4-E-009 Radiated Emission Test Result

**Test Site** : DDT 3m Chamber 2#

E:\E3\_Report\TestData\Q21051406-1E Du smart buds\RF.EM6

**Test Date** : 05-26-2021

**Tested By** : Ella

**EUT** : Du smart buds

**Model Number** : XD-SWA14-2101

**Power Supply** : Battery

**Test Mode** : Tx mode

**Condition** : Temp:24.5°C,Humi:55%,Press:100.1kPa

**Antenna/Distance** : 2021 BBHA9120D/3m/VERTICAL

**Memo** : Right 2DH5 2402MHz

Data: 5

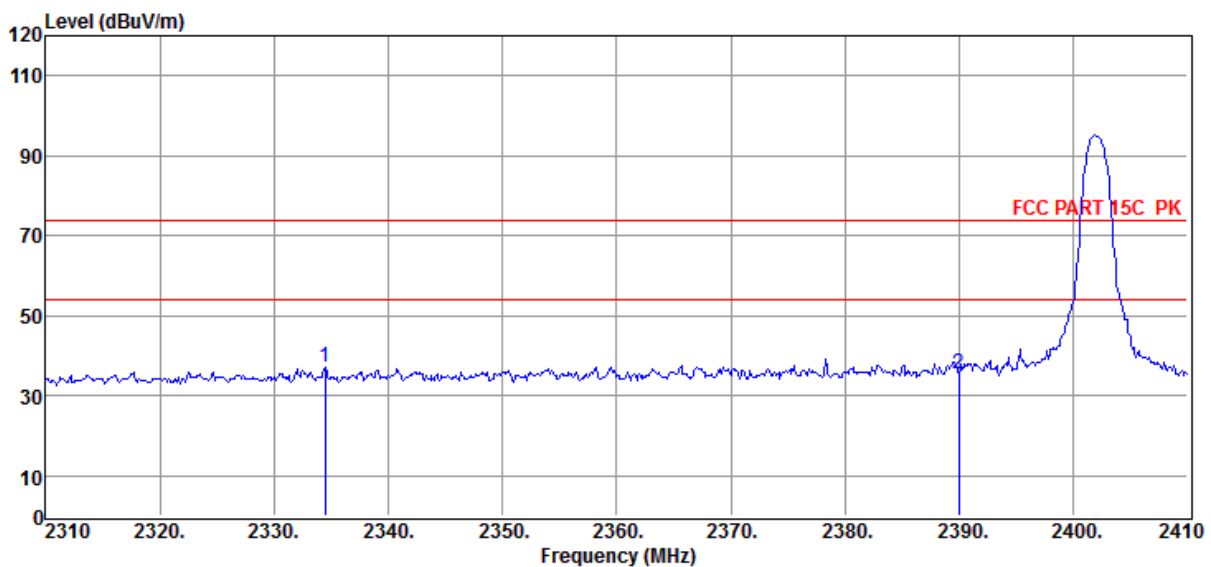

Item (Mark)	Freq. (MHz)	Read Level (dBμV)	Antenna Factor (dB/m)	PRM Factor (dB)	Cable Loss (dB)	Result Level (dBμV/m)	Limit Line (dBμV/m)	Over Limit (dB)	Detector	Polarization
1	2334.50	42.85	28.13	0.00	-33.98	37.00	74.00	-37.00	Peak	VERTICAL
2	2390.00	41.53	28.05	0.00	-34.02	35.56	74.00	-38.44	Peak	VERTICAL

Note: 1. Result Level = Read Level + Antenna Factor + Cable loss - PRM Factor.

2. If Peak Result complies with AV limit, AV Result is deemed to comply with AV limit.

3. Test setup: RBW: 1 MHz, VBW: 3 MHz, Sweep time: auto.

## TR-4-E-009 Radiated Emission Test Result

**Test Site** : DDT 3m Chamber 2#

E:\E3\_Report\TestData\Q21051406-1E Du smart buds\RF.EM6

**Test Date** : 05-26-2021

**Tested By** : Ella

**EUT** : Du smart buds

**Model Number** : XD-SWA14-2101

**Power Supply** : Battery

**Test Mode** : Tx mode

**Condition** : Temp:24.5°C,Humi:55%,Press:100.1kPa

**Antenna/Distance** : 2021 BBHA9120D/3m/HORIZONTAL

**Memo** : Right 2DH5 2402MHz

Data: 6

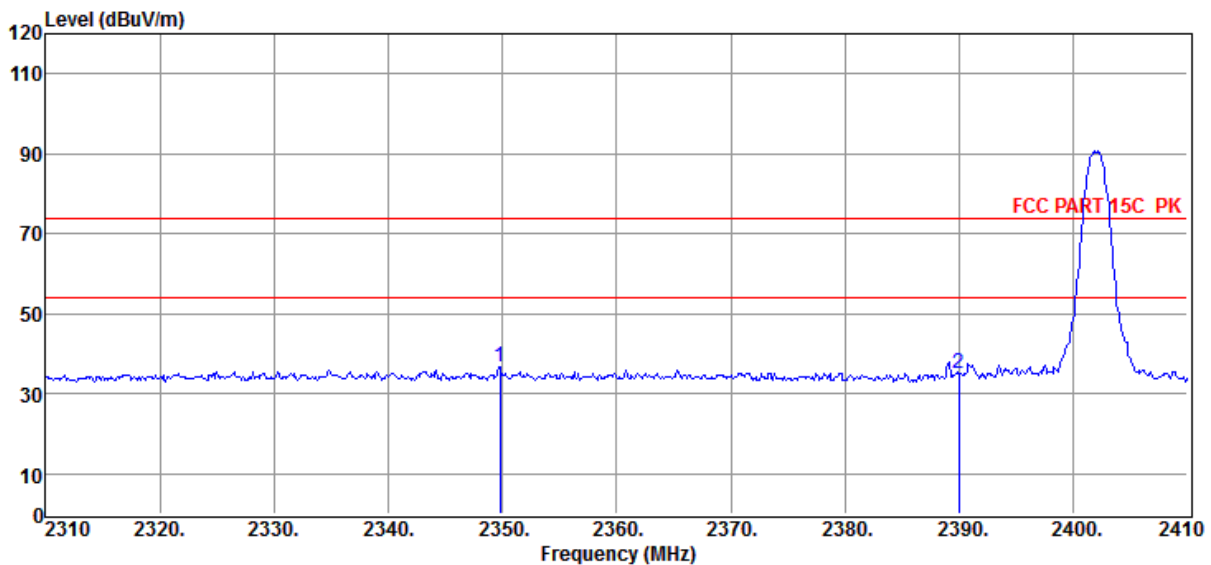

Item (Mark)	Freq. (MHz)	Read Level (dBμV)	Antenna Factor (dB/m)	PRM Factor (dB)	Cable Loss (dB)	Result Level (dBμV/m)	Limit Line (dBμV/m)	Over Limit (dB)	Detector	Polarization
1	2349.80	42.37	28.11	0.00	-33.96	36.52	74.00	-37.48	Peak	HORIZONTAL
2	2390.00	41.13	28.05	0.00	-34.02	35.16	74.00	-38.84	Peak	HORIZONTAL

Note: 1. Result Level = Read Level + Antenna Factor + Cable loss - PRM Factor.

2. If Peak Result complies with AV limit, AV Result is deemed to comply with AV limit.

3. Test setup: RBW: 1 MHz, VBW: 3 MHz, Sweep time: auto.

# TR-4-E-009 Radiated Emission Test Result

**Test Site** : DDT 3m Chamber 2# **E:\E3\_Report\TestData\Q21051406-1E Du smart buds\RF.EM6**  
**Test Date** : 05-26-2021 **Tested By** : Ella  
**EUT** : Du smart buds **Model Number** : XD-SWA14-2101  
**Power Supply** : Battery **Test Mode** : Tx mode  
**Condition** : Temp:24.5°C,Humi:55%,Press:100.1kPa **Antenna/Distance** : 2021 BBHA9120D/3m/HORIZONTAL  
**Memo** : Right 2DH5 2480MHz

Data: 7

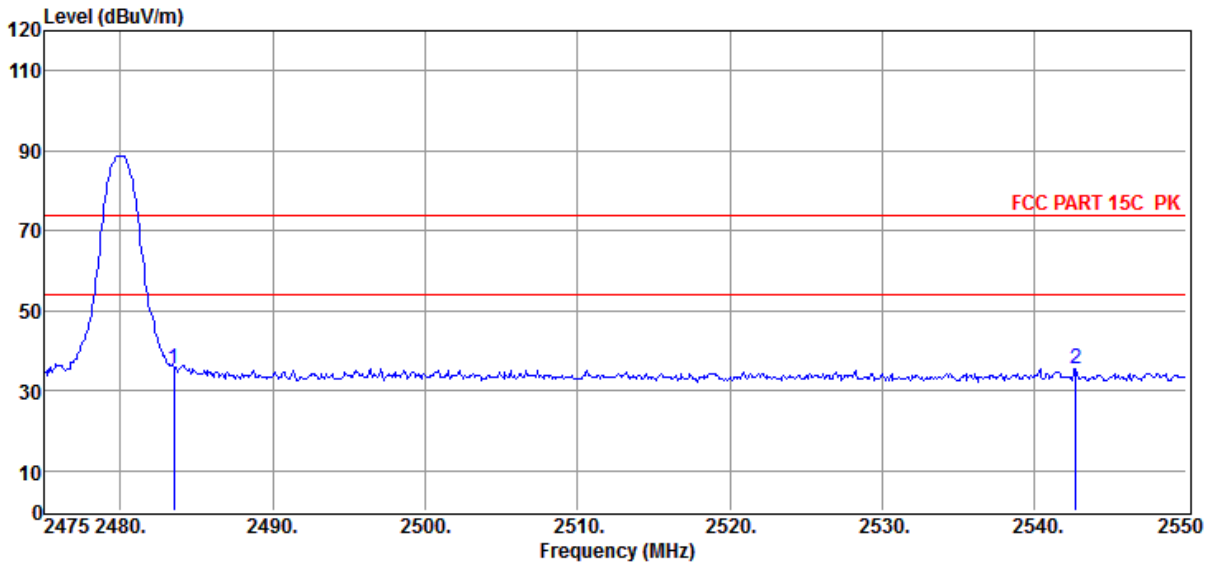

Item (Mark)	Freq. (MHz)	Read Level (dBμV)	Antenna Factor (dB/m)	PRM Factor (dB)	Cable Loss (dB)	Result Level (dBμV/m)	Limit Line (dBμV/m)	Over Limit (dB)	Detector	Polarization
1	2483.50	41.39	27.92	0.00	-33.79	35.52	74.00	-38.48	Peak	HORIZONTAL
2	2542.73	41.08	28.01	0.00	-33.54	35.55	74.00	-38.45	Peak	HORIZONTAL

- Note: 1. Result Level = Read Level + Antenna Factor + Cable loss - PRM Factor.  
 2. If Peak Result complies with AV limit, AV Result is deemed to comply with AV limit.  
 3. Test setup: RBW: 1 MHz, VBW: 3 MHz, Sweep time: auto.

## TR-4-E-009 Radiated Emission Test Result

**Test Site** : DDT 3m Chamber 2#

E:\E3\_Report\TestData\Q21051406-1E Du smart buds\RF.EM6

**Test Date** : 05-26-2021

**Tested By** : Ella

**EUT** : Du smart buds

**Model Number** : XD-SWA14-2101

**Power Supply** : Battery

**Test Mode** : Tx mode

**Condition** : Temp:24.5°C,Humi:55%,Press:100.1kPa

**Antenna/Distance** : 2021 BBHA9120D/3m/VERTICAL

**Memo** : Right 2DH5 2480MHz

Data: 8

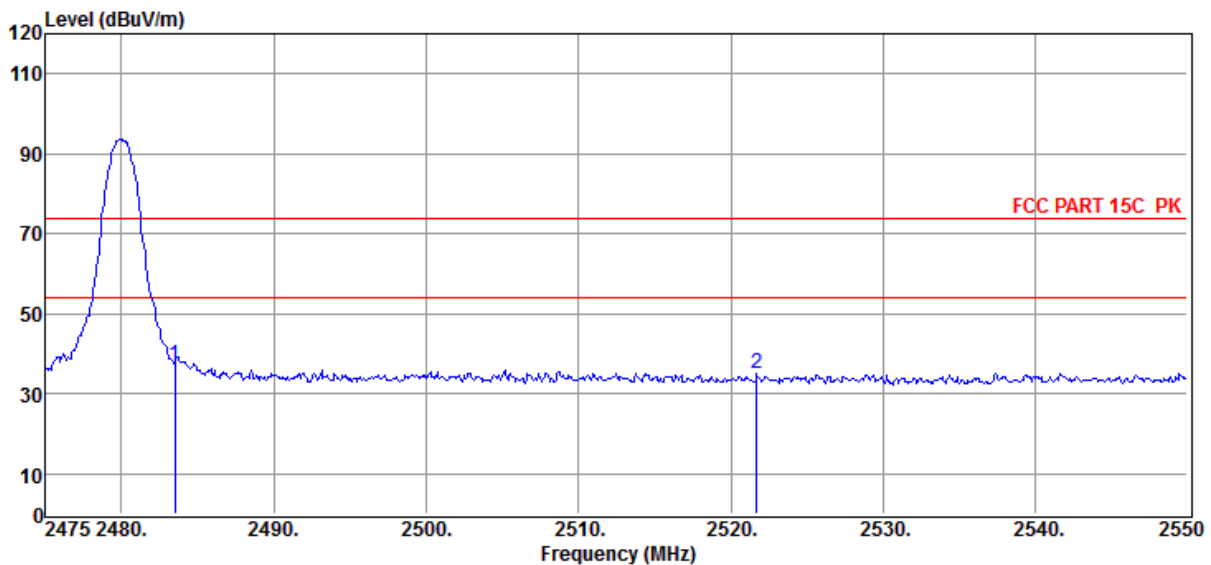

Item (Mark)	Freq. (MHz)	Read Level (dBμV)	Antenna Factor (dB/m)	PRM Factor (dB)	Cable Loss (dB)	Result Level (dBμV/m)	Limit Line (dBμV/m)	Over Limit (dB)	Detector	Polarization
1	2483.48	43.09	27.92	0.00	-33.79	37.22	74.00	-36.78	Peak	VERTICAL
2	2521.73	40.60	27.96	0.00	-33.53	35.03	74.00	-38.97	Peak	VERTICAL

Note: 1. Result Level = Read Level + Antenna Factor + Cable loss - PRM Factor.

2. If Peak Result complies with AV limit, AV Result is deemed to comply with AV limit.

3. Test setup: RBW: 1 MHz, VBW: 3 MHz, Sweep time: auto.

## TR-4-E-009 Radiated Emission Test Result

**Test Site** : DDT 3m Chamber 2#  
**Test Date** : 05-26-2021  
**EUT** : Du smart buds  
**Power Supply** : Battery  
**Condition** : Temp:24.5°C,Humi:55%,Press:100.1kPa  
**Memo** : Right 3DH5 2402MHz  
**E:\E3\_Report\TestData\Q21051406-1E Du smart buds\RF.EM6**  
**Tested By** : Ella  
**Model Number** : XD-SWA14-2101  
**Test Mode** : Tx mode  
**Antenna/Distance** : 2021 BBHA9120D/3m/HORIZONTAL

Data: 9

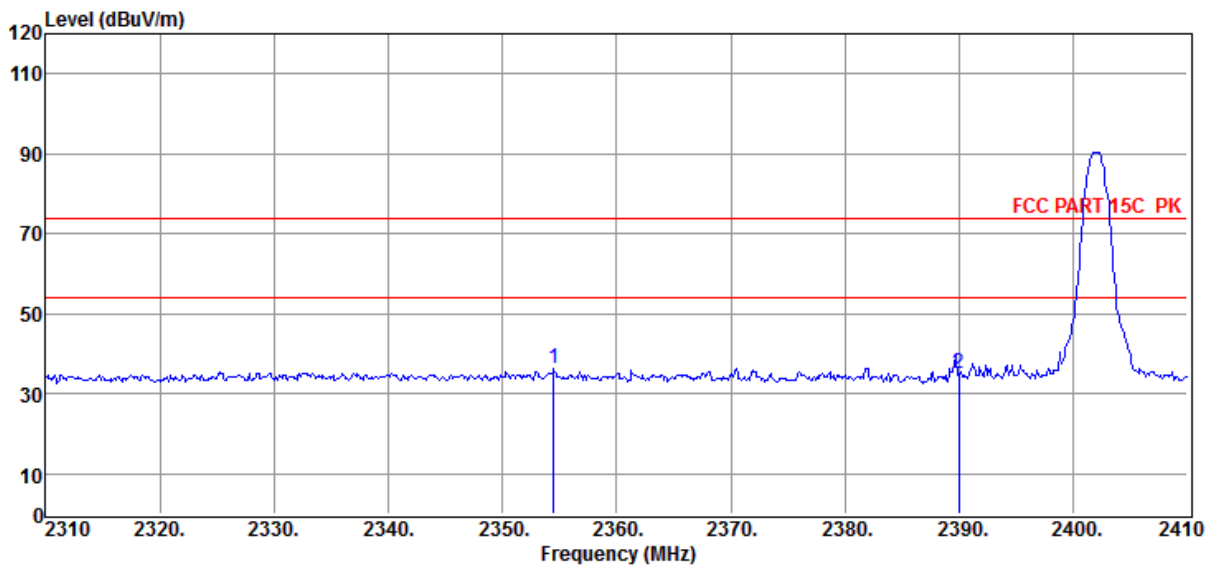

Item (Mark)	Freq. (MHz)	Read Level (dB $\mu$ V)	Antenna Factor (dB/m)	PRM Factor (dB)	Cable Loss (dB)	Result Level (dB $\mu$ V/m)	Limit Line (dB $\mu$ V/m)	Over Limit (dB)	Detector	Polarization
1	2354.50	42.14	28.10	0.00	-33.97	36.27	74.00	-37.73	Peak	HORIZONTAL
2	2390.00	41.01	28.05	0.00	-34.02	35.04	74.00	-38.96	Peak	HORIZONTAL

Note: 1. Result Level = Read Level + Antenna Factor + Cable loss - PRM Factor.

2. If Peak Result complies with AV limit, AV Result is deemed to comply with AV limit.

3. Test setup: RBW: 1 MHz, VBW: 3 MHz, Sweep time: auto.

## TR-4-E-009 Radiated Emission Test Result

**Test Site** : DDT 3m Chamber 2#

E:\E3\_Report\TestData\Q21051406-1E Du smart buds\RF.EM6

**Test Date** : 05-26-2021

**Tested By** : Ella

**EUT** : Du smart buds

**Model Number** : XD-SWA14-2101

**Power Supply** : Battery

**Test Mode** : Tx mode

**Condition** : Temp:24.5°C,Humi:55%,Press:100.1kPa

**Antenna/Distance** : 2021 BBHA9120D/3m/VERTICAL

**Memo** : Right 3DH5 2402MHz

Data: 10

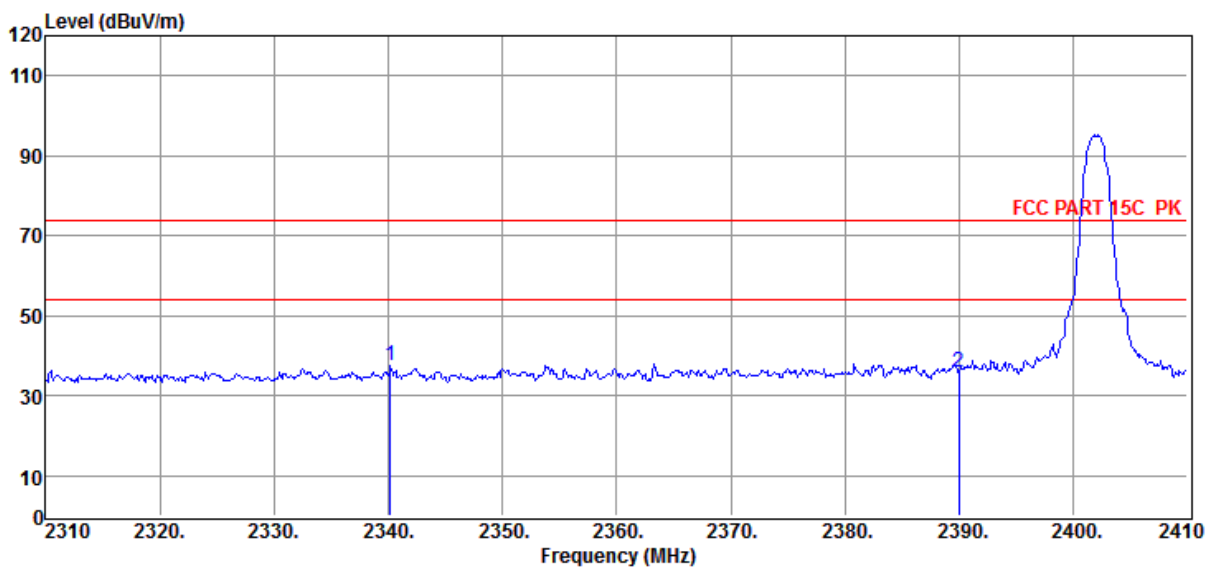

Item (Mark)	Freq. (MHz)	Read Level (dB $\mu$ V)	Antenna Factor (dB/m)	PRM Factor (dB)	Cable Loss (dB)	Result Level (dB $\mu$ V/m)	Limit Line (dB $\mu$ V/m)	Over Limit (dB)	Detector	Polarization
1	2340.20	43.42	28.12	0.00	-33.95	37.59	74.00	-36.41	Peak	VERTICAL
2	2390.00	41.83	28.05	0.00	-34.02	35.86	74.00	-38.14	Peak	VERTICAL

Note: 1. Result Level = Read Level + Antenna Factor + Cable loss - PRM Factor.

2. If Peak Result complies with AV limit, AV Result is deemed to comply with AV limit.

3. Test setup: RBW: 1 MHz, VBW: 3 MHz, Sweep time: auto.

## TR-4-E-009 Radiated Emission Test Result

**Test Site** : DDT 3m Chamber 2#

E:\E3\_Report\TestData\Q21051406-1E Du smart buds\RF.EM6

**Test Date** : 05-26-2021

**Tested By** : Ella

**EUT** : Du smart buds

**Model Number** : XD-SWA14-2101

**Power Supply** : Battery

**Test Mode** : Tx mode

**Condition** : Temp:24.5°C,Humi:55%,Press:100.1kPa

**Antenna/Distance** : 2021 BBHA9120D/3m/VERTICAL

**Memo** : Right 3DH5 2480MHz

Data: 11

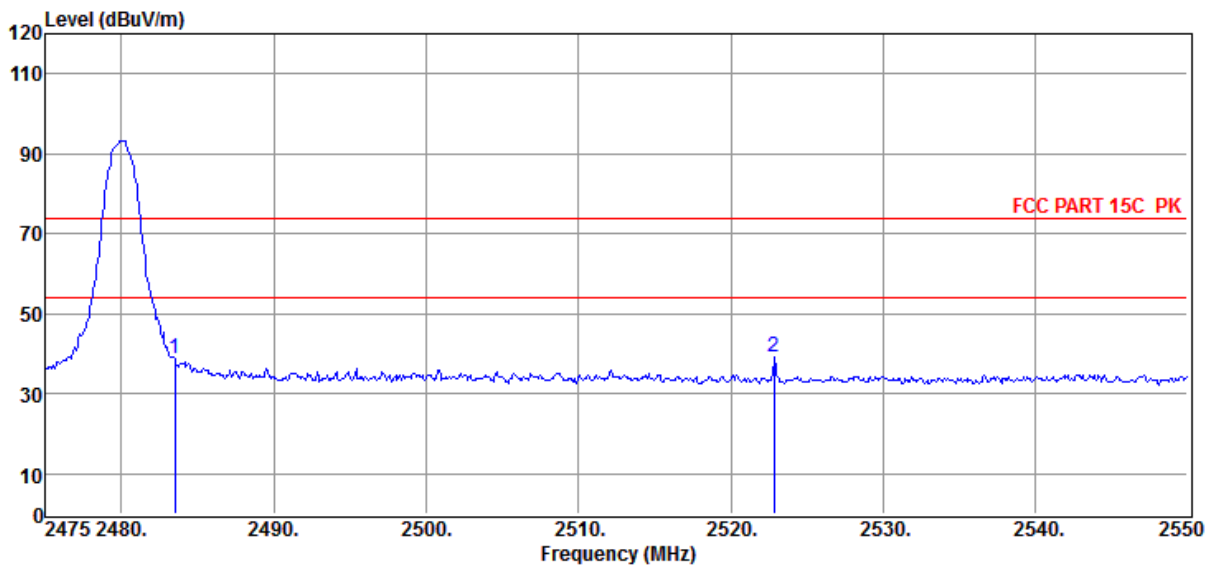

Item (Mark)	Freq. (MHz)	Read Level (dBμV)	Antenna Factor (dB/m)	PRM Factor (dB)	Cable Loss (dB)	Result Level (dBμV/m)	Limit Line (dBμV/m)	Over Limit (dB)	Detector	Polarization
1	2483.50	44.66	27.92	0.00	-33.79	38.79	74.00	-35.21	Peak	VERTICAL
2	2522.85	44.60	27.96	0.00	-33.53	39.03	74.00	-34.97	Peak	VERTICAL

Note: 1. Result Level = Read Level + Antenna Factor + Cable loss - PRM Factor.

2. If Peak Result complies with AV limit, AV Result is deemed to comply with AV limit.

3. Test setup: RBW: 1 MHz, VBW: 3 MHz, Sweep time: auto.



# TR-4-E-009 Radiated Emission Test Result

**Test Site** : DDT 3m Chamber 2# E:\E3\_Report\TestData\Q21051406-1E Du smart buds\RF.EM6  
**Test Date** : 05-26-2021 **Tested By** : Ella  
**EUT** : Du smart buds **Model Number** : XD-SWA14-2101  
**Power Supply** : Battery **Test Mode** : Tx mode  
**Condition** : Temp:24.5°C,Humi:55%,Press:100.1kPa **Antenna/Distance** : 2021 BBHA9120D/3m/HORIZONTAL  
**Memo** : Right 3DH5 2480MHz

Data: 12

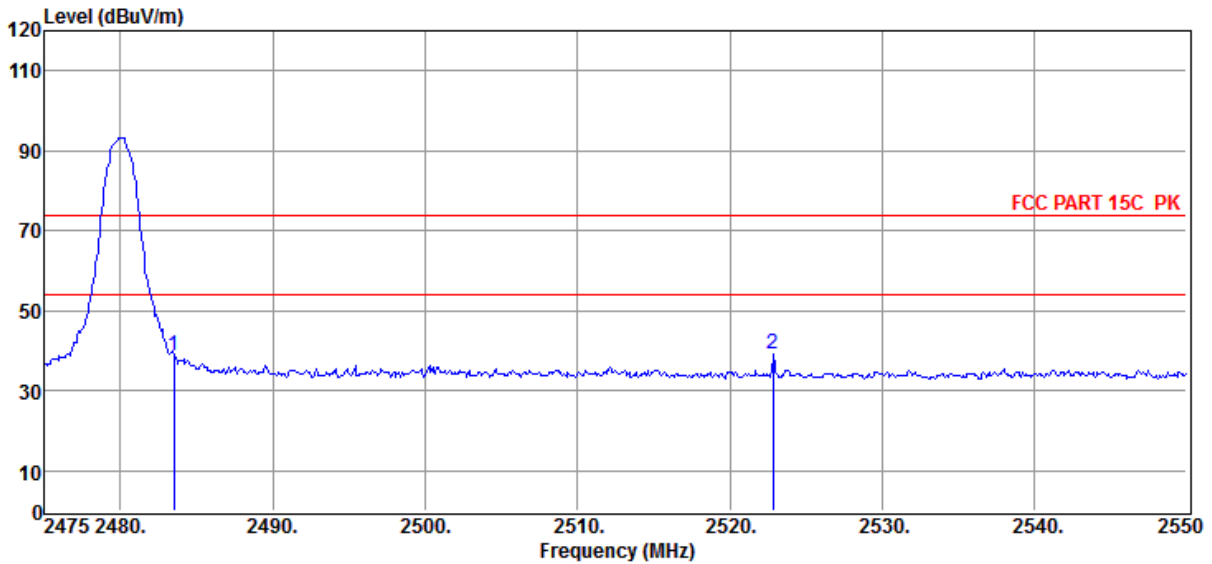

Item (Mark)	Freq. (MHz)	Read Level (dBμV)	Antenna Factor (dB/m)	PRM Factor (dB)	Cable Loss (dB)	Result Level (dBμV/m)	Limit Line (dBμV/m)	Over Limit (dB)	Detector	Polarization
1	2483.50	44.66	27.92	0.00	-33.79	38.79	74.00	-35.21	Peak	HORIZONTAL
2	2522.85	44.60	27.96	0.00	-33.53	39.03	74.00	-34.97	Peak	HORIZONTAL

- Note: 1. Result Level = Read Level + Antenna Factor + Cable loss - PRM Factor.  
 2. If Peak Result complies with AV limit, AV Result is deemed to comply with AV limit.  
 3. Test setup: RBW: 1 MHz, VBW: 3 MHz, Sweep time: auto.

## TR-4-E-009 Radiated Emission Test Result

**Test Site** : DDT 3m Chamber 2# **E:\E3\_Report\TestData\Q21051406-1E Du smart buds\RF.EM6**  
**Test Date** : 05-26-2021 **Tested By** : Ella  
**EUT** : Du smart buds **Model Number** : XD-SWA14-2101  
**Power Supply** : Battery **Test Mode** : Tx mode  
**Condition** : Temp:24.5°C,Humi:55%,Press:100.1kPa **Antenna/Distance** : 2021 BBHA9120D/3m/HORIZONTAL  
**Memo** : Left DH5 2402MHz

Data: 13

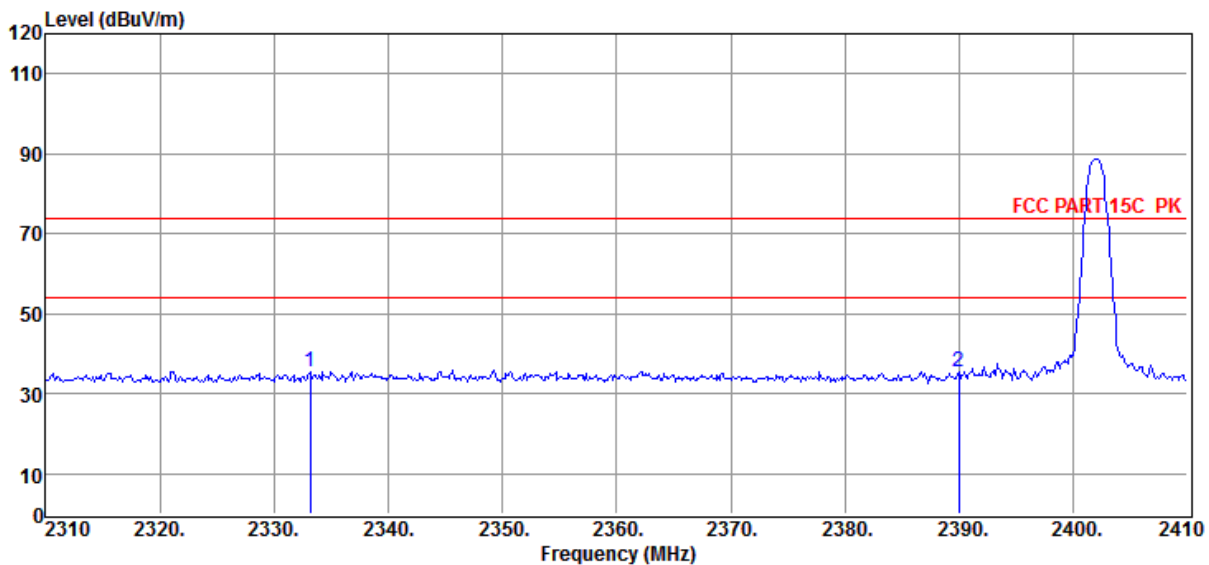

Item (Mark)	Freq. (MHz)	Read Level (dB $\mu$ V)	Antenna Factor (dB/m)	PRM Factor (dB)	Cable Loss (dB)	Result Level (dB $\mu$ V/m)	Limit Line (dB $\mu$ V/m)	Over Limit (dB)	Detector	Polarization
1	2333.20	41.52	28.13	0.00	-33.99	35.66	74.00	-38.34	Peak	HORIZONTAL
2	2390.00	41.47	28.05	0.00	-34.02	35.50	74.00	-38.50	Peak	HORIZONTAL

Note: 1. Result Level = Read Level + Antenna Factor + Cable loss - PRM Factor.

2. If Peak Result complies with AV limit, AV Result is deemed to comply with AV limit.

3. Test setup: RBW: 1 MHz, VBW: 3 MHz, Sweep time: auto.

## TR-4-E-009 Radiated Emission Test Result

**Test Site** : DDT 3m Chamber 2#

E:\E3\_Report\TestData\Q21051406-1E Du smart buds\RF.EM6

**Test Date** : 05-26-2021

**Tested By** : Ella

**EUT** : Du smart buds

**Model Number** : XD-SWA14-2101

**Power Supply** : Battery

**Test Mode** : Tx mode

**Condition** : Temp:24.5°C,Humi:55%,Press:100.1kPa

**Antenna/Distance** : 2021 BBHA9120D/3m/VERTICAL

**Memo** : Left DH5 2402MHz

Data: 14

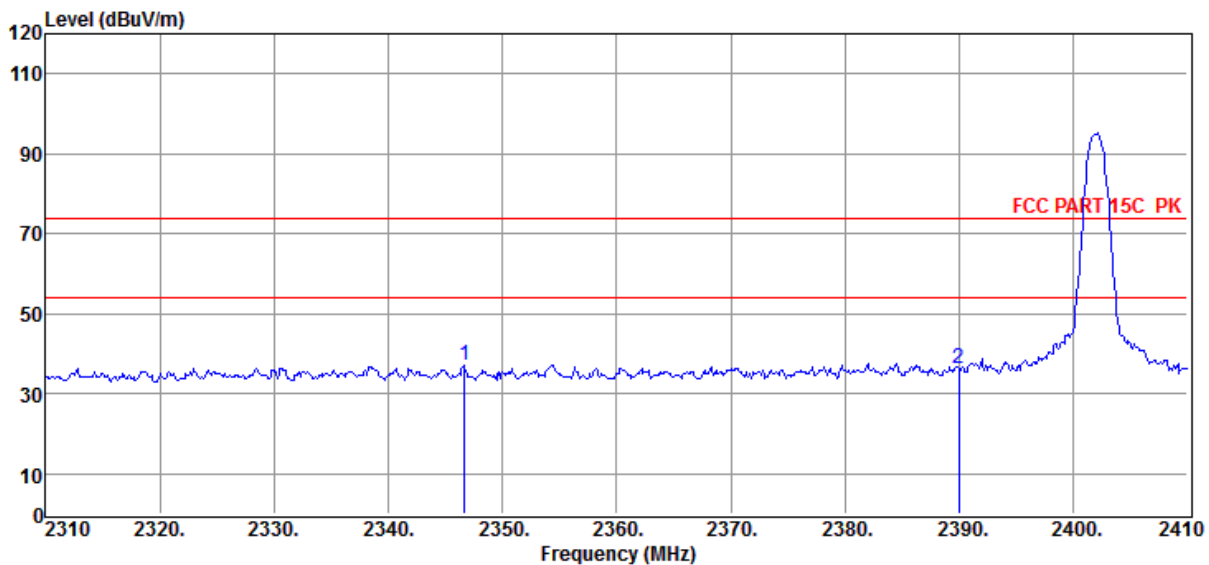

Item (Mark)	Freq. (MHz)	Read Level (dB $\mu$ V)	Antenna Factor (dB/m)	PRM Factor dB	Cable Loss dB	Result Level (dB $\mu$ V/m)	Limit Line (dB $\mu$ V/m)	Over Limit (dB)	Detector	Polarization
1	2346.70	42.95	28.11	0.00	-33.96	37.10	74.00	-36.90	Peak	VERTICAL
2	2390.00	42.34	28.05	0.00	-34.02	36.37	74.00	-37.63	Peak	VERTICAL

Note: 1. Result Level = Read Level + Antenna Factor + Cable loss - PRM Factor.

2. If Peak Result complies with AV limit, AV Result is deemed to comply with AV limit.

3. Test setup: RBW: 1 MHz, VBW: 3 MHz, Sweep time: auto.

# TR-4-E-009 Radiated Emission Test Result

**Test Site** : DDT 3m Chamber 2# **E:\E3\_Report\TestData\Q21051406-1E Du smart buds\RF.EM6**  
**Test Date** : 05-26-2021 **Tested By** : Ella  
**EUT** : Du smart buds **Model Number** : XD-SWA14-2101  
**Power Supply** : Battery **Test Mode** : Tx mode  
**Condition** : Temp:24.5°C,Humi:55%,Press:100.1kPa **Antenna/Distance** : 2021 BBHA9120D/3m/VERTICAL  
**Memo** : Left DH5 2480MHz

Data: 15

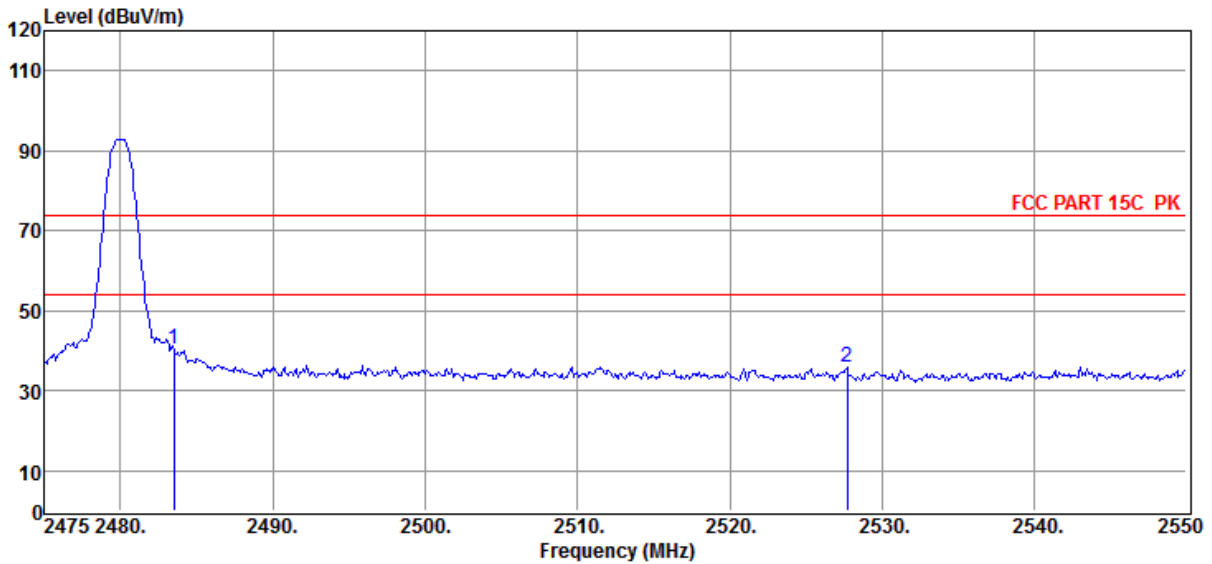

Item (Mark)	Freq. (MHz)	Read Level (dBμV)	Antenna Factor (dB/m)	PRM Factor (dB)	Cable Loss (dB)	Result Level (dBμV/m)	Limit Line (dBμV/m)	Over Limit (dB)	Detector	Polarization
1	2483.50	46.43	27.92	0.00	-33.79	40.56	74.00	-33.44	Peak	VERTICAL
2	2527.73	41.39	27.97	0.00	-33.54	35.82	74.00	-38.18	Peak	VERTICAL

- Note: 1. Result Level = Read Level + Antenna Factor + Cable loss - PRM Factor.  
 2. If Peak Result complies with AV limit, AV Result is deemed to comply with AV limit.  
 3. Test setup: RBW: 1 MHz, VBW: 3 MHz, Sweep time: auto.

## TR-4-E-009 Radiated Emission Test Result

**Test Site** : DDT 3m Chamber 2#

E:\E3\_Report\TestData\Q21051406-1E Du smart buds\RF.EM6

**Test Date** : 05-26-2021

**Tested By** : Ella

**EUT** : Du smart buds

**Model Number** : XD-SWA14-2101

**Power Supply** : Battery

**Test Mode** : Tx mode

**Condition** : Temp:24.5°C,Humi:55%,Press:100.1kPa

**Antenna/Distance** : 2021 BBHA9120D/3m/HORIZONTAL

**Memo** : Left DH5 2480MHz

Data: 16

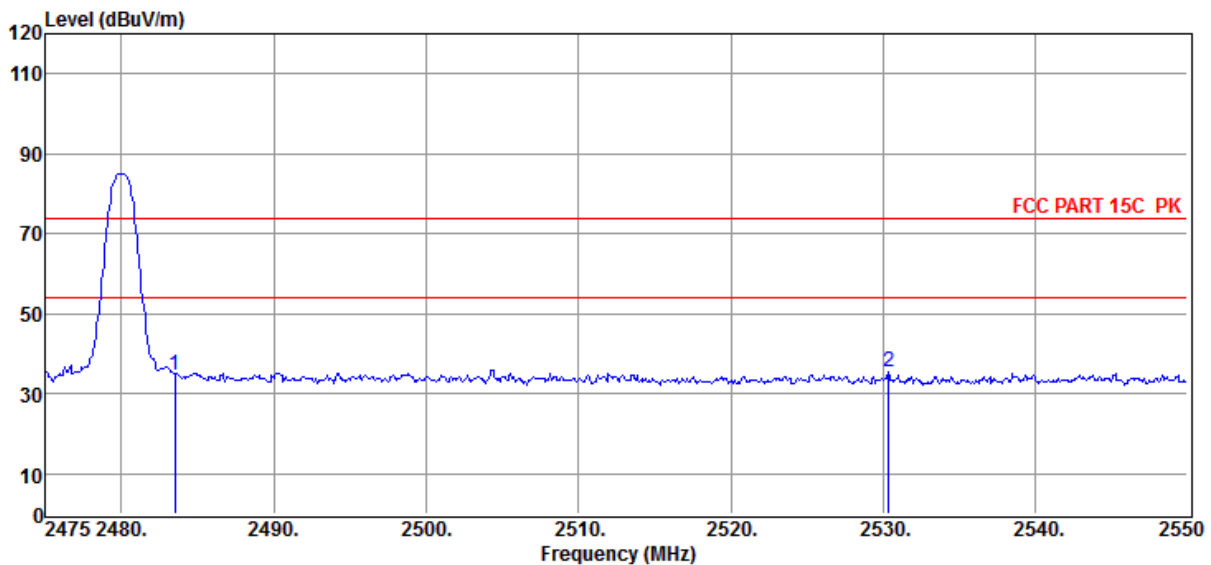

Item (Mark)	Freq. (MHz)	Read Level (dBuV)	Antenna Factor (dB/m)	PRM Factor (dB)	Cable Loss (dB)	Result Level (dBuV/m)	Limit Line (dBuV/m)	Over Limit (dB)	Detector	Polarization
1	2483.50	40.51	27.92	0.00	-33.79	34.64	74.00	-39.36	Peak	HORIZONTAL
2	2530.35	40.97	27.98	0.00	-33.54	35.41	74.00	-38.59	Peak	HORIZONTAL

Note: 1. Result Level = Read Level + Antenna Factor + Cable loss - PRM Factor.

2. If Peak Result complies with AV limit, AV Result is deemed to comply with AV limit.

3. Test setup: RBW: 1 MHz, VBW: 3 MHz, Sweep time: auto.

## TR-4-E-009 Radiated Emission Test Result

**Test Site** : DDT 3m Chamber 2#

E:\E3\_Report\TestData\Q21051406-1E Du smart buds\RF.EM6

**Test Date** : 05-26-2021

**Tested By** : Ella

**EUT** : Du smart buds

**Model Number** : XD-SWA14-2101

**Power Supply** : Battery

**Test Mode** : Tx mode

**Condition** : Temp:24.5°C,Humi:55%,Press:100.1kPa

**Antenna/Distance** : 2021 BBHA9120D/3m/VERTICAL

**Memo** : Left 2DH5 2402MHz

Data: 17

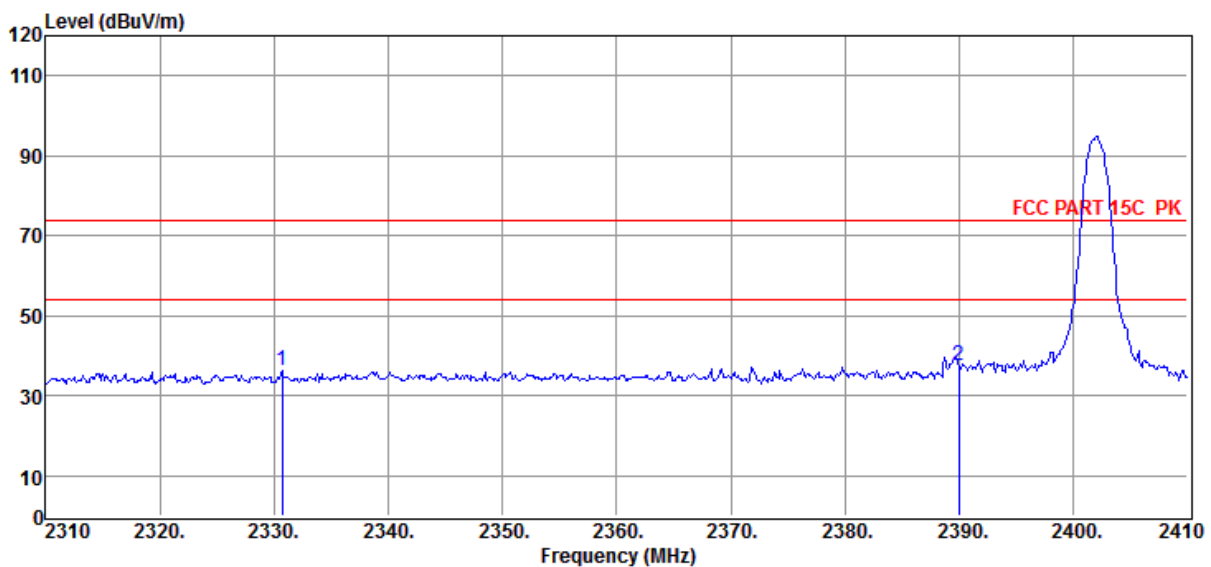

Item (Mark)	Freq. (MHz)	Read Level (dB $\mu$ V)	Antenna Factor (dB/m)	PRM Factor dB	Cable Loss dB	Result Level (dB $\mu$ V/m)	Limit Line (dB $\mu$ V/m)	Over Limit (dB)	Detector	Polarization
1	2330.70	42.17	28.14	0.00	-34.00	36.31	74.00	-37.69	Peak	VERTICAL
2	2390.00	43.59	28.05	0.00	-34.02	37.62	74.00	-36.38	Peak	VERTICAL

Note: 1. Result Level = Read Level + Antenna Factor + Cable loss - PRM Factor.

2. If Peak Result complies with AV limit, AV Result is deemed to comply with AV limit.

3. Test setup: RBW: 1 MHz, VBW: 3 MHz, Sweep time: auto.

# TR-4-E-009 Radiated Emission Test Result

**Test Site** : DDT 3m Chamber 2# E:\E3\_Report\TestData\Q21051406-1E Du smart buds\RF.EM6  
**Test Date** : 05-26-2021 **Tested By** : Ella  
**EUT** : Du smart buds **Model Number** : XD-SWA14-2101  
**Power Supply** : Battery **Test Mode** : Tx mode  
**Condition** : Temp:24.5°C,Humi:55%,Press:100.1kPa **Antenna/Distance** : 2021 BBHA9120D/3m/HORIZONTAL  
**Memo** : Left 2DH5 2402MHz

Data: 18

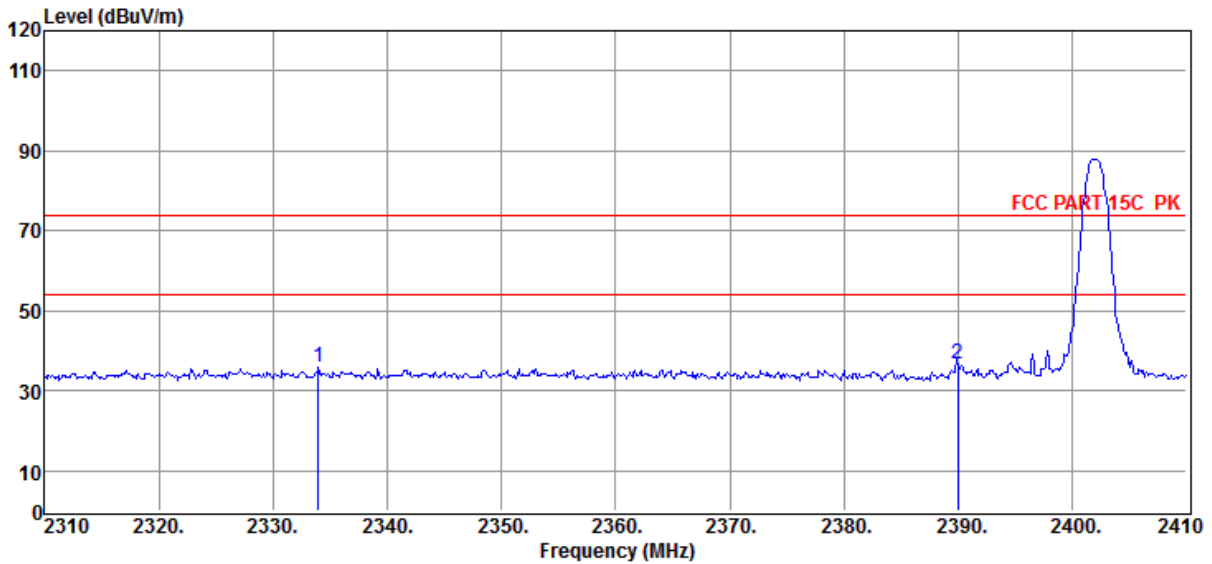

Item (Mark)	Freq. (MHz)	Read Level (dBµV)	Antenna Factor (dB/m)	PRM Factor (dB)	Cable Loss (dB)	Result Level (dBµV/m)	Limit Line (dBµV/m)	Over Limit (dB)	Detector	Polarization
1	2334.00	41.54	28.13	0.00	-33.98	35.69	74.00	-38.31	Peak	HORIZONTAL
2	2390.00	42.79	28.05	0.00	-34.02	36.82	74.00	-37.18	Peak	HORIZONTAL

- Note: 1. Result Level = Read Level + Antenna Factor + Cable loss - PRM Factor.  
 2. If Peak Result complies with AV limit, AV Result is deemed to comply with AV limit.  
 3. Test setup: RBW: 1 MHz, VBW: 3 MHz, Sweep time: auto.

## TR-4-E-009 Radiated Emission Test Result

**Test Site** : DDT 3m Chamber 2#

E:\E3\_Report\TestData\Q21051406-1E Du smart buds\RF.EM6

**Test Date** : 05-26-2021

**Tested By** : Ella

**EUT** : Du smart buds

**Model Number** : XD-SWA14-2101

**Power Supply** : Battery

**Test Mode** : Tx mode

**Condition** : Temp:24.5°C,Humi:55%,Press:100.1kPa

**Antenna/Distance** : 2021 BBHA9120D/3m/HORIZONTAL

**Memo** : Left 2DH5 2480MHz

Data: 19

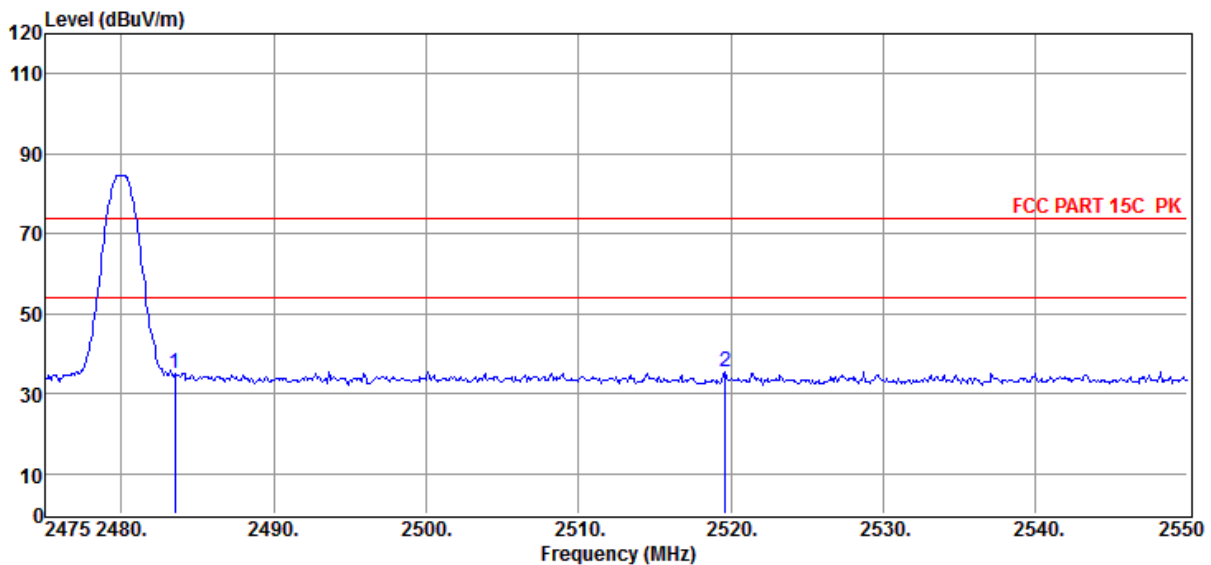

Item (Mark)	Freq. (MHz)	Read Level (dB $\mu$ V)	Antenna Factor (dB/m)	PRM Factor (dB)	Cable Loss (dB)	Result Level (dB $\mu$ V/m)	Limit Line (dB $\mu$ V/m)	Over Limit (dB)	Detector	Polarization
1	2483.50	40.76	27.92	0.00	-33.79	34.89	74.00	-39.11	Peak	HORIZONTAL
2	2519.63	41.02	27.95	0.00	-33.53	35.44	74.00	-38.56	Peak	HORIZONTAL

Note: 1. Result Level = Read Level + Antenna Factor + Cable loss - PRM Factor.

2. If Peak Result complies with AV limit, AV Result is deemed to comply with AV limit.

3. Test setup: RBW: 1 MHz, VBW: 3 MHz, Sweep time: auto.



## TR-4-E-009 Radiated Emission Test Result

**Test Site** : DDT 3m Chamber 2#  
**Test Date** : 05-26-2021  
**EUT** : Du smart buds  
**Power Supply** : Battery  
**Condition** : Temp:24.5°C,Humi:55%,Press:100.1kPa  
**Memo** : Left 2DH5 2480MHz

**E:\E3\_Report\TestData\Q21051406-1E Du smart buds\RF.EM6**  
**Tested By** : Ella  
**Model Number** : XD-SWA14-2101  
**Test Mode** : Tx mode  
**Antenna/Distance** : 2021 BBHA9120D/3m/VERTICAL

Data: 20

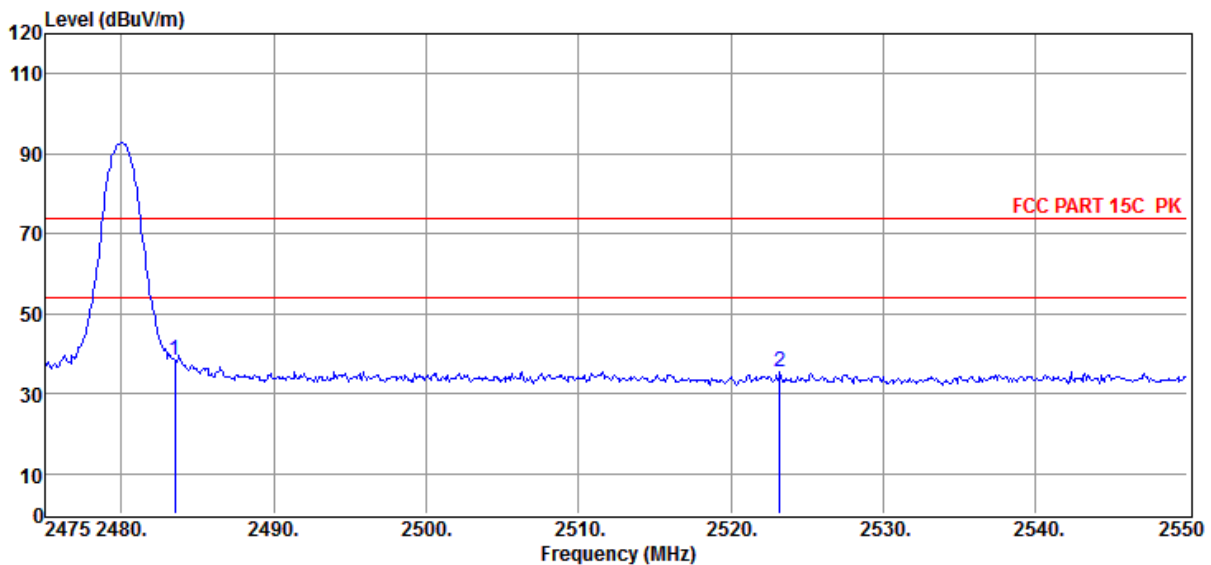

Item (Mark)	Freq. (MHz)	Read Level (dBuV)	Antenna Factor (dB/m)	PRM Factor (dB)	Cable Loss (dB)	Result Level (dBuV/m)	Limit Line (dBuV/m)	Over Limit (dB)	Detector	Polarization
1	2483.50	44.27	27.92	0.00	-33.79	38.40	74.00	-35.60	Peak	VERTICAL
2	2523.23	40.85	27.96	0.00	-33.53	35.28	74.00	-38.72	Peak	VERTICAL

Note: 1. Result Level = Read Level + Antenna Factor + Cable loss - PRM Factor.

2. If Peak Result complies with AV limit, AV Result is deemed to comply with AV limit.

3. Test setup: RBW: 1 MHz, VBW: 3 MHz, Sweep time: auto.

## TR-4-E-009 Radiated Emission Test Result

**Test Site** : DDT 3m Chamber 2#

E:\E3\_Report\TestData\Q21051406-1E Du smart buds\RF.EM6

**Test Date** : 05-26-2021

**Tested By** : Ella

**EUT** : Du smart buds

**Model Number** : XD-SWA14-2101

**Power Supply** : Battery

**Test Mode** : Tx mode

**Condition** : Temp:24.5°C,Humi:55%,Press:100.1kPa

**Antenna/Distance** : 2021 BBHA9120D/3m/HORIZONTAL

**Memo** : Left 3DH5 2402MHz

Data: 21

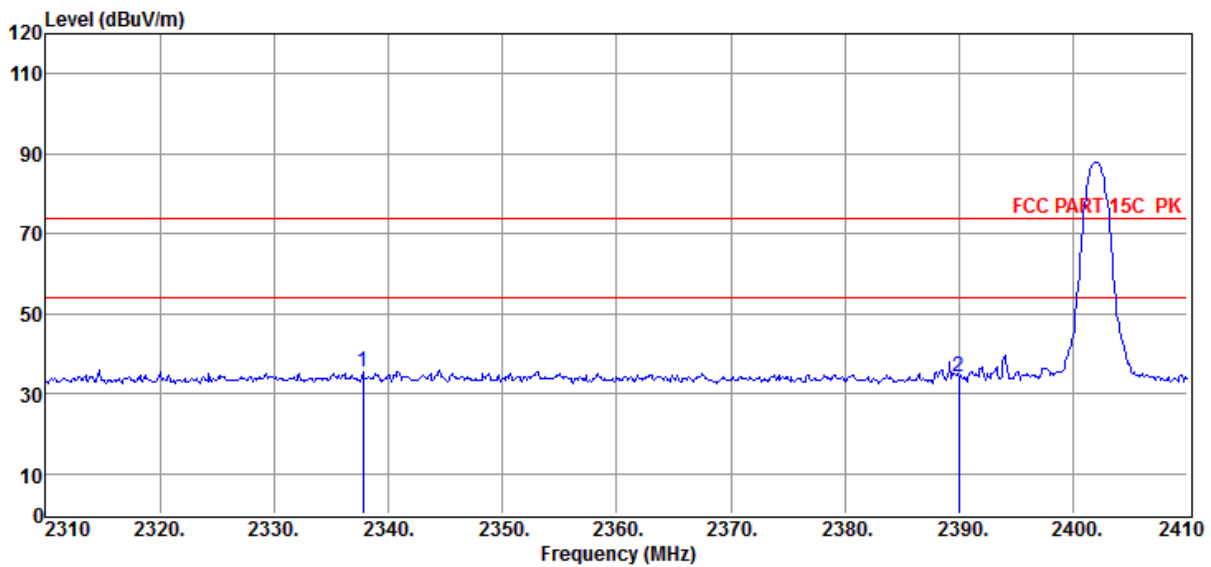

Item (Mark)	Freq. (MHz)	Read Level (dBuV)	Antenna Factor (dB/m)	PRM Factor (dB)	Cable Loss (dB)	Result Level (dBuV/m)	Limit Line (dBuV/m)	Over Limit (dB)	Detector	Polarization
1	2337.80	41.34	28.13	0.00	-33.96	35.51	74.00	-38.49	Peak	HORIZONTAL
2	2390.00	40.11	28.05	0.00	-34.02	34.14	74.00	-39.86	Peak	HORIZONTAL

Note: 1. Result Level = Read Level + Antenna Factor + Cable loss - PRM Factor.

2. If Peak Result complies with AV limit, AV Result is deemed to comply with AV limit.

3. Test setup: RBW: 1 MHz, VBW: 3 MHz, Sweep time: auto.

# TR-4-E-009 Radiated Emission Test Result

**Test Site** : DDT 3m Chamber 2# **E:\E3\_Report\TestData\Q21051406-1E Du smart buds\RF.EM6**  
**Test Date** : 05-26-2021 **Tested By** : Ella  
**EUT** : Du smart buds **Model Number** : XD-SWA14-2101  
**Power Supply** : Battery **Test Mode** : Tx mode  
**Condition** : Temp:24.5°C,Humi:55%,Press:100.1kPa **Antenna/Distance** : 2021 BBHA9120D/3m/VERTICAL  
**Memo** : Left 3DH5 2402MHz

Data: 22

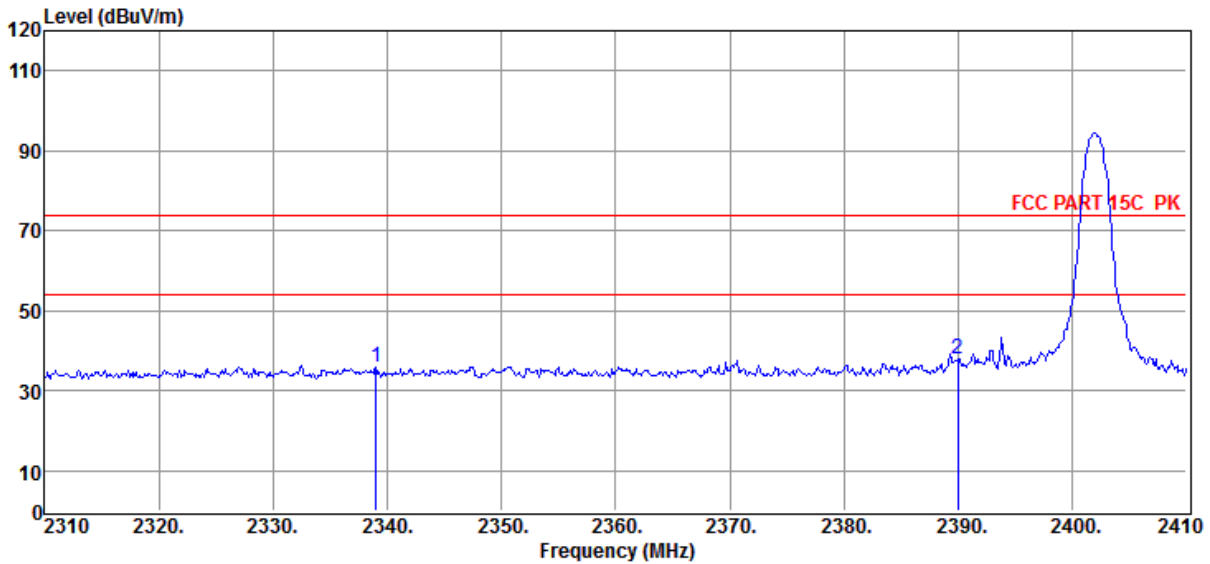

Item (Mark)	Freq. (MHz)	Read Level (dBμV)	Antenna Factor (dB/m)	PRM Factor (dB)	Cable Loss (dB)	Result Level (dBμV/m)	Limit Line (dBμV/m)	Over Limit (dB)	Detector	Polarization
1	2339.00	41.75	28.13	0.00	-33.96	35.92	74.00	-38.08	Peak	VERTICAL
2	2390.00	43.91	28.05	0.00	-34.02	37.94	74.00	-36.06	Peak	VERTICAL

- Note: 1. Result Level = Read Level + Antenna Factor + Cable loss - PRM Factor.  
 2. If Peak Result complies with AV limit, AV Result is deemed to comply with AV limit.  
 3. Test setup: RBW: 1 MHz, VBW: 3 MHz, Sweep time: auto.

## TR-4-E-009 Radiated Emission Test Result

**Test Site** : DDT 3m Chamber 2#

E:\E3\_Report\TestData\Q21051406-1E Du smart buds\RF.EM6

**Test Date** : 05-26-2021

**Tested By** : Ella

**EUT** : Du smart buds

**Model Number** : XD-SWA14-2101

**Power Supply** : Battery

**Test Mode** : Tx mode

**Condition** : Temp:24.5°C,Humi:55%,Press:100.1kPa

**Antenna/Distance** : 2021 BBHA9120D/3m/VERTICAL

**Memo** : Left 3DH5 2480MHz

Data: 23

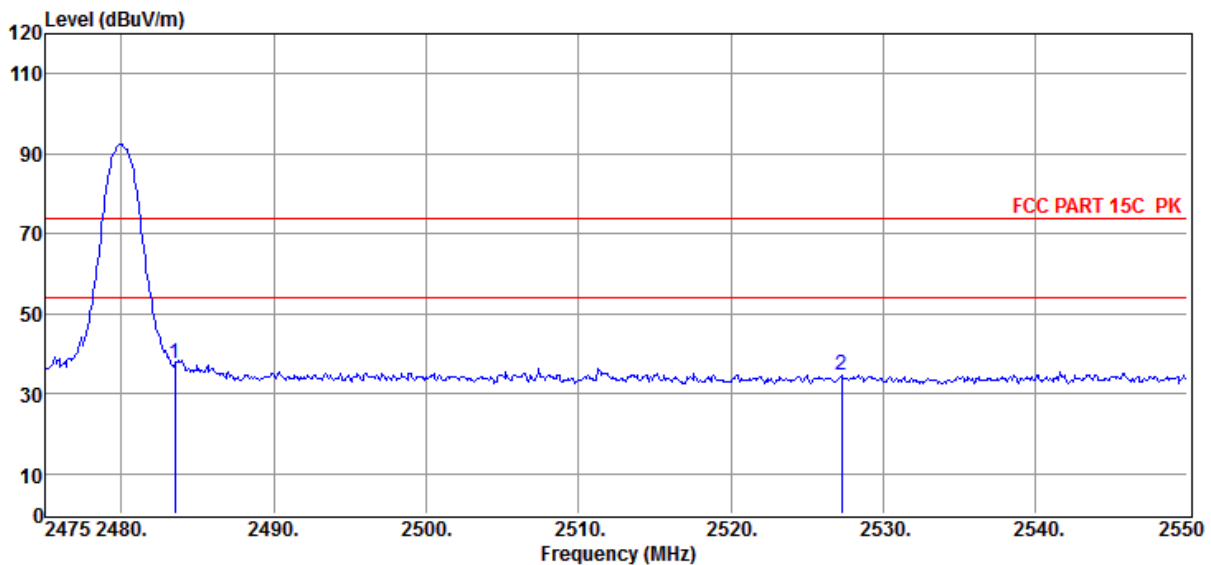

Item (Mark)	Freq. (MHz)	Read Level (dBuV)	Antenna Factor (dB/m)	PRM Factor (dB)	Cable Loss (dB)	Result Level (dBuV/m)	Limit Line (dBuV/m)	Over Limit (dB)	Detector	Polarization
1	2483.50	43.46	27.92	0.00	-33.79	37.59	74.00	-36.41	Peak	VERTICAL
2	2527.28	40.25	27.97	0.00	-33.54	34.68	74.00	-39.32	Peak	VERTICAL

Note: 1. Result Level = Read Level + Antenna Factor + Cable loss - PRM Factor.

2. If Peak Result complies with AV limit, AV Result is deemed to comply with AV limit.

3. Test setup: RBW: 1 MHz, VBW: 3 MHz, Sweep time: auto.

# TR-4-E-009 Radiated Emission Test Result

**Test Site** : DDT 3m Chamber 2# **E:\E3\_Report\TestData\Q21051406-1E Du smart buds\RF.EM6**  
**Test Date** : 05-26-2021 **Tested By** : Ella  
**EUT** : Du smart buds **Model Number** : XD-SWA14-2101  
**Power Supply** : Battery **Test Mode** : Tx mode  
**Condition** : Temp:24.5°C,Humi:55%,Press:100.1kPa **Antenna/Distance** : 2021 BBHA9120D/3m/HORIZONTAL  
**Memo** : Left 3DH5 2480MHz

Data: 24

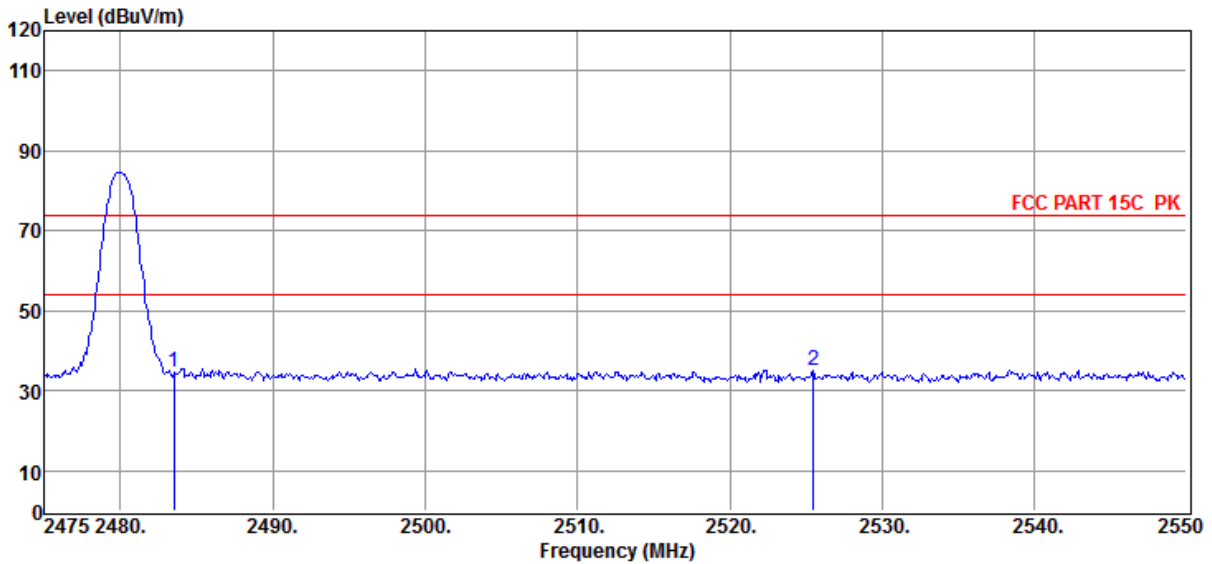

Item (Mark)	Freq. (MHz)	Read Level (dBμV)	Antenna Factor (dB/m)	PRM Factor (dB)	Cable Loss (dB)	Result Level (dBμV/m)	Limit Line (dBμV/m)	Over Limit (dB)	Detector	Polarization
1	2483.50	40.50	27.92	0.00	-33.79	34.63	74.00	-39.37	Peak	HORIZONTAL
2	2525.48	40.82	27.97	0.00	-33.54	35.25	74.00	-38.75	Peak	HORIZONTAL

- Note: 1. Result Level = Read Level + Antenna Factor + Cable loss - PRM Factor.  
 2. If Peak Result complies with AV limit, AV Result is deemed to comply with AV limit.  
 3. Test setup: RBW: 1 MHz, VBW: 3 MHz, Sweep time: auto.

## 13. Power Line Conducted Emission

### 13.1. Block diagram of test setup

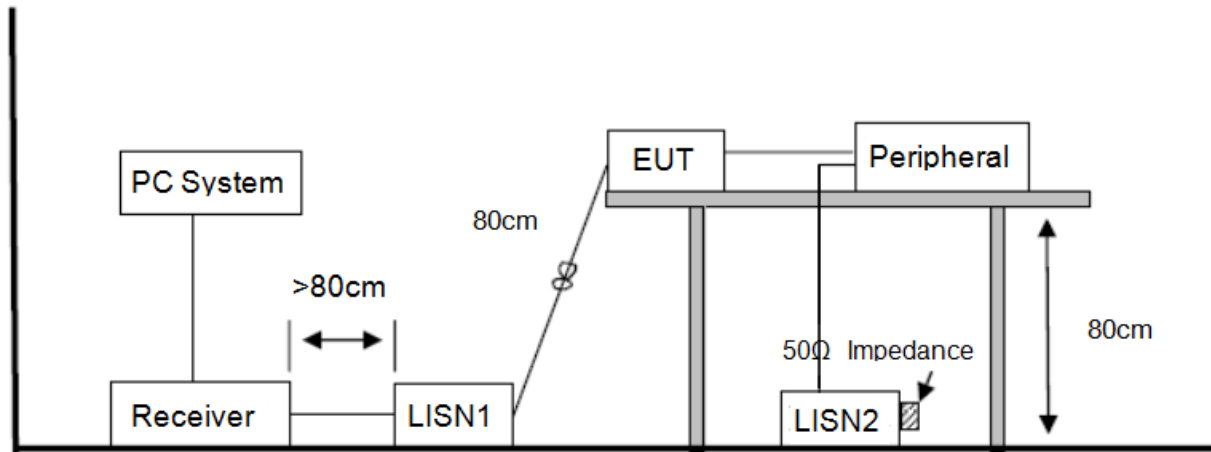

### 13.2. Power line conducted emission limits

Frequency	Quasi-Peak Level dB( $\mu$ V)	Average Level dB( $\mu$ V)
150 kHz ~ 500 kHz	66 ~ 56*	56 ~ 46*
500 kHz ~ 5 MHz	56	46
5 MHz ~ 30 MHz	60	50

Note 1: \* Decreasing linearly with logarithm of frequency.

Note 2: The lower limit shall apply at the transition frequencies.

### 13.3. Test procedure

The EUT and Support equipment, if needed, were put placed on a non-metallic table, 80cm above the ground plane.

Configuration EUT to simulate typical usage as described in clause 2.4 and test equipment as described in clause 10.2 of this report.

All I/O cables were positioned to simulate typical actual usage as per ANSI C63.10.

All support equipment power received from a second LISN.

Emissions were measured on each current carrying line of the EUT using an EMI Test Receiver connected to the LISN powering the EUT.

The Receiver scanned from 150 kHz to 30 MHz for emissions in each of the test modes.

During the above scans, the emissions were maximized by cable manipulation.

The test mode(s) described in clause 2.4 were scanned during the preliminary test.

After the preliminary scan, we found the test mode producing the highest emission level.

The EUT configuration and worse cable configuration of the above highest emission levels were recorded for reference of the final test.

EUT and support equipment were set up on the test bench as per the configuration with highest emission level in the preliminary test.

A scan was taken on both power lines, Neutral and Line, recording at least the six highest emissions.

Emission frequency and amplitude were recorded into a computer in which correction factors were used to calculate the emission level and compare reading to the applicable limit.

The test data of the worst-case condition(s) was recorded.

The bandwidth of test receiver is set at 9 kHz.

#### 13.4. Test result

##### **PASS. (See below detailed test result)**

Note1: All emissions not reported below are too low against the prescribed limits.

Note2: "----" means Peak detection; "-----" means Average detection.

Note3: Pre-test AC conducted emission at both voltage AC 120V/60Hz and AC 240V/50Hz, recorded worse case.

# TR-4-E-010 Conducted Emission Test Result

**Test Site** : DDT 2# Shield Room E:\2021E3ReportTestData\Q21061003-1E CE\CE.EM6  
**Test Date** : 2021-06-15 **Tested By** : Sunny  
**EUT** : Du smart buds **Model Number** : XD-SWA14-2101  
**Power Supply** : AC 120V/60Hz **Test Mode** : Tx mode  
**Condition** : Temp:24.2°C,Humi:45%,Press:100.2kPa **LISN** : ENV216 L/LINE  
**Memo** :

Data: 2

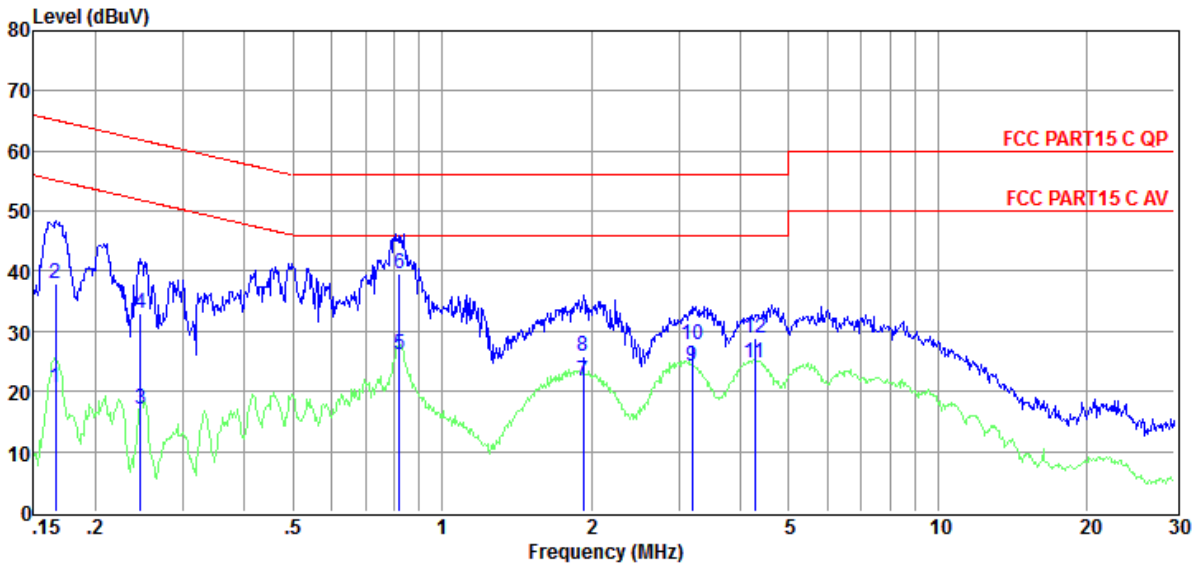

Item (Mark)	Freq. (MHz)	Read Level (dBμV)	Cable Loss (dB)	Result Level (dBμV)	Limit Line (dBμV)	Over Limit (dB)	Detector	Phase
1	0.17	9.96	0.02	20.57	55.13	-34.56	Average	LINE
2	0.17	27.41	0.02	38.02	65.13	-27.11	QP	LINE
3	0.25	6.72	0.05	17.12	51.86	-34.74	Average	LINE
4	0.25	22.63	0.05	33.03	61.86	-28.83	QP	LINE
5	0.82	15.92	0.07	26.09	46.00	-19.91	Average	LINE
6	0.82	29.40	0.07	39.57	56.00	-16.43	QP	LINE
7	1.93	11.57	0.12	21.79	46.00	-24.21	Average	LINE
8	1.93	15.61	0.12	25.83	56.00	-30.17	QP	LINE
9	3.19	13.94	0.15	24.19	46.00	-21.81	Average	LINE
10	3.19	17.52	0.15	27.77	56.00	-28.23	QP	LINE
11	4.27	14.45	0.16	24.72	46.00	-21.28	Average	LINE
12	4.27	18.53	0.16	28.80	56.00	-27.20	QP	LINE

- Note: 1. Result Level = Read Level + LISN Factor + Pulse Limiter Factor + Cable loss.  
 2. If QP Result complies with AV limit, AV Result is deemed to comply with AV limit.  
 3. Test setup: RBW: 200 Hz (9 kHz—150 kHz), 9 kHz (150 kHz—30 MHz).  
 4. Step size: 80Hz (0.009MHz-0.15MHz), 4 kHz (0.15MHz-30MHz), Scan time: auto.



# TR-4-E-010 Conducted Emission Test Result

**Test Site** : DDT 2# Shield Room E:\2021E3ReportTestData\Q21061003-1E CE\CE.EM6  
**Test Date** : 2021-06-15 **Tested By** : Sunny  
**EUT** : Du smart buds **Model Number** : XD-SWA14-2101  
**Power Supply** : AC 120V/60Hz **Test Mode** : Tx mode  
**Condition** : Temp:24.2°C,Humi:45%,Press:100.2kPa **LISN** : ENV216 L/NEUTRAL  
**Memo** :

Data: 4

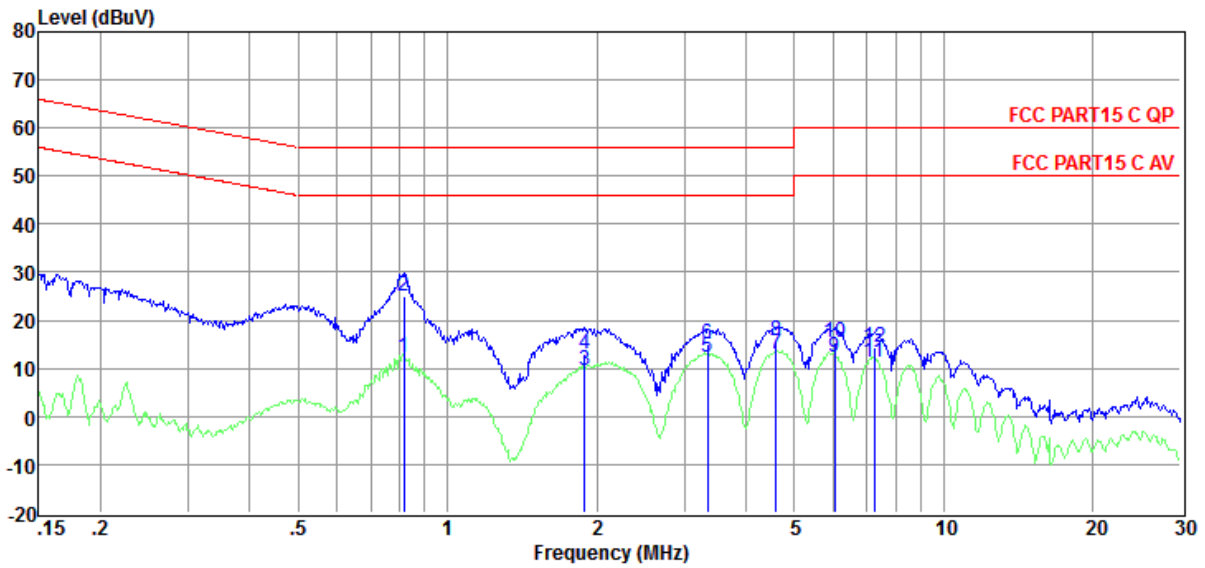

Item (Mark)	Freq. (MHz)	Read Level (dBµV)	Cable Loss (dB)	Result Level (dBµV)	Limit Line (dBµV)	Over Limit (dB)	Detector	Phase
1	0.82	12.36	0.07	12.43	46.00	-33.57	Average	NEUTRAL
2	0.82	25.01	0.07	25.08	56.00	-30.92	QP	NEUTRAL
3	1.89	9.40	0.12	9.52	46.00	-36.48	Average	NEUTRAL
4	1.89	12.78	0.12	12.90	56.00	-43.10	QP	NEUTRAL
5	3.35	12.29	0.15	12.44	46.00	-33.56	Average	NEUTRAL
6	3.35	14.97	0.15	15.12	56.00	-40.88	QP	NEUTRAL
7	4.60	12.67	0.17	12.84	46.00	-33.16	Average	NEUTRAL
8	4.60	15.57	0.17	15.74	56.00	-40.26	QP	NEUTRAL
9	6.02	12.11	0.18	12.29	50.00	-37.71	Average	NEUTRAL
10	6.02	15.06	0.18	15.24	60.00	-44.76	QP	NEUTRAL
11	7.25	11.16	0.19	11.35	50.00	-38.65	Average	NEUTRAL
12	7.25	14.12	0.19	14.31	60.00	-45.69	QP	NEUTRAL

- Note: 1. Result Level = Read Level + LISN Factor + Pulse Limiter Factor + Cable loss.  
 2. If QP Result complies with AV limit, AV Result is deemed to comply with AV limit.  
 3. Test setup: RBW: 200 Hz (9 kHz—150 kHz), 9 kHz (150 kHz—30 MHz).  
 4. Step size: 80Hz (0.009MHz-0.15MHz), 4 kHz (0.15MHz-30MHz), Scan time: auto.

## 14. Antenna Requirements

### 14.1. Limit

For intentional device, according to FCC 47 CFR Section 15.203, an intentional radiator shall be designed to ensure that no antenna other than that furnished by the responsible party shall be used with the device. And according to FCC 47 CFR Section 15.247 (b), if transmitting antennas of directional gain greater than 6 dBi are used, the power shall be reduced by the amount in dB that the directional gain of the antenna exceeds 6 dBi.

### 14.2. Result

The left side antenna used for this product is FPC antenna and right side is FPC antenna and that no antenna other than that furnished by the responsible party shall be used with the device, the maximum peak gain of the left side transmit antenna is 3.27 dBi and right side is 3.27 dBi.