



FCC RADIO TEST REPORT

FCC ID: 2AWJO-ECO02

Product : ECO Hygiene Micro-Station

Trade Mark : Soapy Care

Model Name : ECO-02

Family Model : N/A

Report No. : S20050801802001

Prepared for

Soapy Care Ltd

2nd Oppenheimer st, Rehovot, 7670136 Israel

Prepared by

Shenzhen NTEK Testing Technology Co., Ltd.

1/F, Building E, Fenda Science Park, Sanwei Community, Xixiang Street
Bao'an District, Shenzhen 518126 P.R. China

Tel.: +86-755-6115 6588 Fax.: +86-755-6115 6599

Website: <http://www.ntek.org.cn>

TEST RESULT CERTIFICATION

Applicant's name : Soapy Care Ltd
Address : 2nd Oppenheimer st, Rehovot, 7670136 Israel

Manufacturer's Name : Soapy Care Ltd
Address : 2nd Oppenheimer st, Rehovot, 7670136 Israel

Product description

Product name..... : ECO Hygiene Micro-Station
Model and/or type reference : ECO-02
Family Model: N/A

Standards : FCC Part15.225

Test procedure ANSI C63.10-2013

This device described above has been tested by NTEK, and the test results show that the equipment under test (EUT) is in compliance with the FCC requirements. And it is applicable only to the tested sample identified in the report.

This report shall not be reproduced except in full, without the written approval of NTEK, this document may be altered or revised by NTEK, personnel only, and shall be noted in the revision of the document.

Date of Test :

Date (s) of performance of tests..... : 08 May. 2020 ~ 19 Jun, 2020

Date of Issue..... : 19 Jun, 2020

Test Result..... : **Pass**

Testing Engineer : Mary Hu
(Mary Hu)

Technical Manager : Jason Chen
(Jason Chen)

Authorized Signatory : Sam Chen
(Sam Chen)

| Table of Contents | Page |
|-------------------------------------------------------------|-----------|
| 1 . SUMMARY OF TEST RESULTS | 4 |
| 1.1 TEST FACILITY | 5 |
| 1.2 MEASUREMENT UNCERTAINTY | 5 |
| 2 . GENERAL INFORMATION | 6 |
| 2.1 GENERAL DESCRIPTION OF EUT | 6 |
| 2.2 DESCRIPTION OF TEST MODES | 7 |
| 2.3 BLOCK DIGRAM SHOWING THE CONFIGURATION OF SYSTEM TESTED | 8 |
| 2.4 DESCRIPTION OF SUPPORT UNITS (CONDUCTED MODE) | 9 |
| 2.5 EQUIPMENTS LIST FOR ALL TEST ITEMS | 10 |
| 3 . ANTENNA REQUIREMENT | 11 |
| 3.1 STANDARD REQUIREMENT | 11 |
| 3.2 EUT ANTENNA | 11 |
| 4 . EMC EMISSION TEST | 12 |
| 4.1 CONDUCTED EMISSION MEASUREMENT | 12 |
| 4.1.1 POWER LINE CONDUCTED EMISSION LIMITS | 12 |
| 4.1.2 TEST CONFIGURATION | 12 |
| 4.1.3 TEST PROCEDURE | 12 |
| 4.1.4 TEST RESULT | 13 |
| 4.2 RADIATED EMISSION MEASUREMENT | 15 |
| 4.2.1 RADIATED EMISSION LIMITS | 15 |
| 4.2.2 TEST PROCEDURE | 16 |
| 4.2.3 DEVIATION FROM TEST STANDARD | 16 |
| 4.2.4 TEST SETUP | 17 |
| 4.2.5 TEST RESULTS (BELOW 30MHZ) | 18 |
| 4.2.6 TEST RESULTS (BETWEEN 30 – 1000 MHZ) | 22 |
| 5 . BANDWIDTH TEST | 24 |
| 5.1 TEST PROCEDURE | 24 |
| 5.2 DEVIATION FROM STANDARD | 24 |
| 5.3 TEST SETUP | 24 |
| 5.4 TEST RESULTS | 25 |
| 6. FREQUENCY TOLERANCE | 26 |

1. SUMMARY OF TEST RESULTS

Test procedures according to the technical standards:

| FCC Part15, Subpart C (15.225) | | | |
|--------------------------------------------|----------------------------------------------------------------------|----------|--------|
| Standard Section | Test Item | Judgment | Remark |
| 15.207 | Conducted Emission | Pass | |
| 15.205(a) 15.209 15.225 (a, b, c, d) | Radiated Spurious Emission Field Strength of Fundamental Emission | Pass | |
| 15.225 15.215(c) | 20dB Bandwidth | Pass | |
| 15.225(e) | Frequency Tolerance | Pass | |
| 15.203 | Antenna Requirement | Pass | |

NOTE:

(1) "N/A" denotes test is not applicable in this Test Report.

1.1 TEST FACILITY

All measurement facilities used to collect the measurement data are located at 1/F, Building E, Fenda Science Park, Sanwei Community, Xixiang Street, Bao'an District, Shenzhen 518126 P.R. China.

The sites are constructed in conformance with the requirements of ANSI C63.7, ANSI C63.10 and CISPR Publication 22.

Site Description

CNAS-Lab. : The Laboratory has been assessed and proved to be in compliance with CNAS-CL01:2006 (identical to ISO/IEC 17025:2005)

The Certificate Registration Number is L5516.

IC-Registration

The Certificate Registration Number is 9270A.

CAB identifier:CN0074

FCC- Accredited

Test Firm Registration Number: 463705.

Designation Number: CN1184

A2LA-Lab.

The Certificate Registration Number is 4298.01

This laboratory is accredited in accordance with the recognized International Standard ISO/IEC 17025:2005 General requirements for the competence of testing and calibration laboratories.

This accreditation demonstrates technical competence for a defined scope and the operation of a laboratory quality management system

(refer to joint ISO-ILAC-IAF Communiqué dated 8 January 2009).

Name of Firm

: Shenzhen NTEK Testing Technology Co., Ltd.

Site Location

: 1/F, Building E, Fenda Science Park, Sanwei Community, Xixiang Street, Bao'an District, Shenzhen 518126 P.R. China.

1.2 MEASUREMENT UNCERTAINTY

The reported uncertainty of measurement $y \pm U$, where expanded uncertainty U is based on a standard uncertainty multiplied by a coverage factor of $k=2$, providing a level of confidence of approximately 95 %.

| No. | Item | Uncertainty |
|-----|------------------------------|-------------------------|
| 1 | Conducted Emission Test | $\pm 1.38\text{dB}$ |
| 2 | RF power,conducted | $\pm 0.16\text{dB}$ |
| 3 | Spurious emissions,conducted | $\pm 0.21\text{dB}$ |
| 4 | All emissions,radiated(<1G) | $\pm 4.68\text{dB}$ |
| 5 | All emissions,radiated(>1G) | $\pm 4.89\text{dB}$ |
| 6 | Temperature | $\pm 0.5^\circ\text{C}$ |
| 7 | Humidity | $\pm 2\%$ |

2. GENERAL INFORMATION

2.1 GENERAL DESCRIPTION OF EUT

| | | |
|---------------------|----------------------------------------|----------------|
| Equipment | ECO Hygiene Micro-Station | |
| Trade Mark | Soapy Care | |
| Model Name | ECO-02 | |
| Family Model | N/A | |
| Model Difference | N/A | |
| Product Description | The EUT is a ECO Hygiene Micro-Station | |
| | Operation Frequency: | 13.56MHz |
| | Modulation Type: | ASK |
| | Number Of Channel | 1CH. |
| | Antenna Designation: | Induction coil |
| Adapter | N/A | |
| Rating | Input: AC100-240V 50/60Hz | |
| HW Version | N/A | |
| SW Version | N/A | |

Note:

1. For a more detailed features description, please refer to the manufacturer's specifications or the User's Manual.
- 2.

Table for Filed Antenna

| Ant | Brand | Model Name | Antenna Type | Connector | Gain (dBi) | NOTE |
|-----|-------|------------|----------------|-----------|------------|---------|
| 1 | N/A | N/A | Induction coil | N/A | N/A | Antenna |

2.2 DESCRIPTION OF TEST MODES

To investigate the maximum EMI emission characteristics generates from EUT, the test system was pre-scanning tested base on the consideration of following EUT operation mode or test configuration mode which possible have effect on EMI emission level. Each of these EUT operation mode(s) or test configuration mode(s) mentioned above was evaluated respectively.

| Pretest Mode | Description |
|--------------|-------------|
| Mode 1 | TX-13.56MHz |

| For Conducted Emission | |
|------------------------|-------------|
| Final Test Mode | Description |
| Mode 1 | TX-13.56MHz |

| For Radiated Emission | |
|-----------------------|-------------|
| Final Test Mode | Description |
| Mode 1 | TX-13.56MHz |

2.3 BLOCK DIGRAM SHOWING THE CONFIGURATION OF SYSTEM TESTED

For AC Conducted Emission Mode

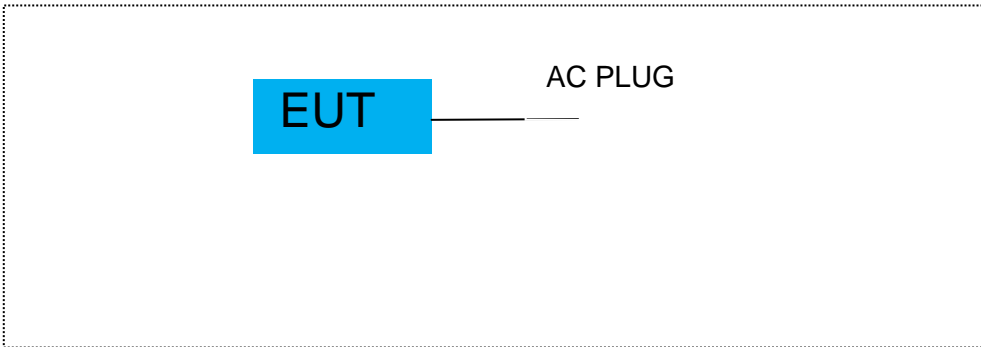

For Radiated Test Cases

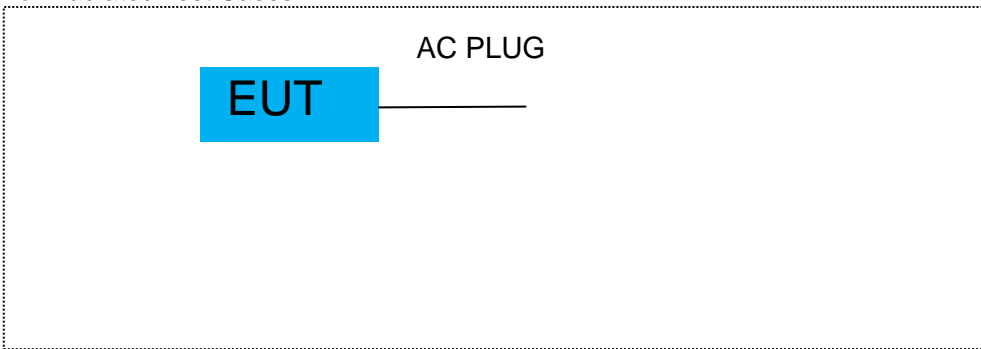

For Conducted Test Cases

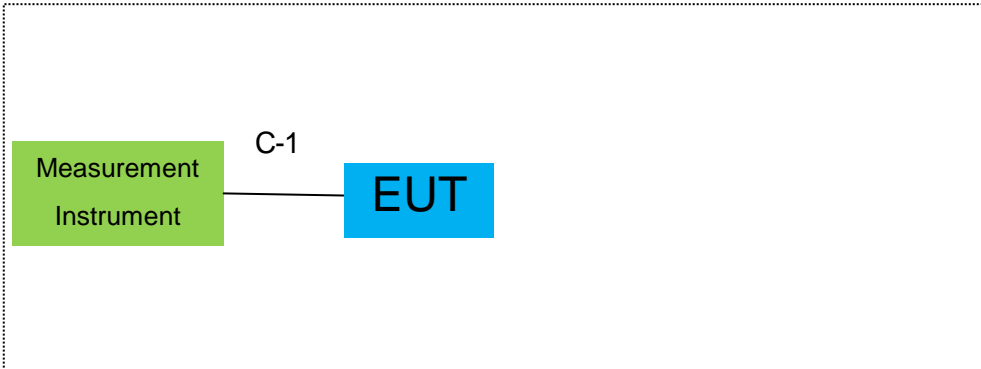

Note:1.The temporary antenna connector is soldered on the PCB board in order to perform conducted tests and this temporary antenna connector is listed in the equipment list.
2.EUT built-in battery-powered, the battery is fully-charged.

2.4 DESCRIPTION OF SUPPORT UNITS (CONDUCTED MODE)

The EUT has been tested as an independent unit together with other necessary accessories or support units. The following support units or accessories were used to form a representative test configuration during the tests.

| Item | Equipment | Brand | Model/Type No. | Series No. | Note |
|------|-----------|-------|----------------|------------|------|
| | | | | | |
| | | | | | |
| | | | | | |
| | | | | | |
| | | | | | |
| | | | | | |
| | | | | | |
| | | | | | |
| | | | | | |
| | | | | | |

| Item | Shielded Type | Ferrite Core | Length | Note |
|------|---------------|--------------|--------|------|
| C-1 | RF Cable | YES | NO | 1.0m |
| | | | | |
| | | | | |
| | | | | |
| | | | | |
| | | | | |

Note:

- (1) The support equipment was authorized by Declaration of Confirmation.
- (2) For detachable type I/O cable should be specified the length in cm in 『Length』 column.

2.5 EQUIPMENTS LIST FOR ALL TEST ITEMS

Radiation & Conducted Test equipment

| Item | Kind of Equipment | Manufacturer | Type No. | Serial No. | Last calibration | Calibrated until | Calibration period |
|------|-----------------------------|--------------|-------------|------------|--------------------------|--------------------------|--------------------|
| 1 | Spectrum Analyzer | Agilent | E4407B | MY45108040 | 2019.05.12 2020.05.11 | 2020.05.11 2021.05.10 | 1 year |
| 2 | Spectrum Analyzer | Agilent | N9020A | MY49100060 | 2019.08.28 | 2020.08.27 | 1 year |
| 3 | Spectrum Analyzer | R&S | FSV40 | 101417 | 2019.08.28 | 2020.08.27 | 1 year |
| 4 | Test Receiver | R&S | ESPI7 | 101318 | 2019.05.12 2020.05.11 | 2020.05.11 2021.05.10 | 1 year |
| 5 | Bilog Antenna | TESEQ | CBL6111D | 31216 | 2020.04.11 | 2021.04.10 | 1 year |
| 6 | 50Ω Coaxial Switch | Anritsu | MP59B | 6200983705 | 2017.05.12 2020.05.11 | 2020.05.11 2023.05.10 | 3 year |
| 7 | Horn Antenna | EM | EM-AH-10180 | 2011071402 | 2020.04.11 | 2021.04.10 | 1 year |
| 8 | Active Loop Antenna | SCHWARZBECK | FMZB 1519B | 055 | 2019.12.11 | 2020.12.10 | 1 year |
| 9 | LF Cable | N/A | R-03 | N/A | 2019.06.28 | 2022.06.27 | 3 year |
| 10 | PSG Analog Signal Generator | Agilent | E8257D | MY51110112 | 2019.08.06 | 2020.08.05 | 1 year |
| 11 | Test Cable (9KHz-30MHz) | N/A | R-01 | N/A | 2019.08.06 | 2022.08.05 | 3 year |
| 12 | Test Cable (30MHz-1GHz) | N/A | R-02 | N/A | 2019.08.06 | 2020.08.05 | 3 year |

AC Conduction Test equipment

| Item | Kind of Equipment | Manufacturer | Type No. | Serial No. | Last calibration | Calibrated until | Calibration period |
|------|-------------------------|--------------|-----------|------------|--------------------------|--------------------------|--------------------|
| 1 | Test Receiver | R&S | ESCI | 101160 | 2019.05.12 2020.05.11 | 2020.05.11 2021.05.10 | 1 year |
| 2 | LISN | R&S | ENV216 | 101313 | 2019.05.12 2020.05.11 | 2020.05.11 2021.05.10 | 1 year |
| 3 | LISN | SCHWARZBECK | NNLK 8129 | 8129245 | 2019.05.12 2020.05.11 | 2020.05.11 2021.05.10 | 1 year |
| 4 | 50Ω Coaxial Switch | ANRITSU CORP | MP59B | 6200983704 | 2017.05.12 2020.05.11 | 2020.05.11 2023.05.10 | 2 year 3 year |
| 5 | Test Cable (9KHz-30MHz) | N/A | C01 | N/A | 2017.05.12 2020.05.11 | 2020.05.11 2023.05.10 | 3 year |
| 6 | Test Cable (9KHz-30MHz) | N/A | C02 | N/A | 2017.05.12 2020.05.11 | 2020.05.11 2023.05.10 | 3 year |
| 7 | Test Cable (9KHz-30MHz) | N/A | C03 | N/A | 2017.05.12 2020.05.11 | 2020.05.11 2023.05.10 | 3 year |

Note:

1. We will use the temporary antenna connector (soldered on the PCB board) When conducted test And this temporary antenna connector is listed within the instrument list
2. Each piece of equipment is scheduled for calibration once a year except the Test Cable & Aux Equipment which is scheduled for calibration every 3 years.

3. ANTENNA REQUIREMENT

3.1 STANDARD REQUIREMENT

15.203 requirement: For intentional device, according to 15.203: an intentional radiator shall be designed to ensure that no antenna other than that furnished by the responsible party shall be used with the device.

3.2 EUT ANTENNA

The EUT antenna is Induction coil antenna. It comply with the standard requirement.

4. EMC EMISSION TEST

4.1 CONDUCTED EMISSION MEASUREMENT

4.1.1 POWER LINE CONDUCTED EMISSION Limits (Frequency Range 150KHz-30MHz)

| Frequency(MHz) | Conducted Emission Limit | |
|----------------|--------------------------|---------|
| | Quasi-peak | Average |
| 0.15-0.5 | 66-56* | 56-46* |
| 0.5-5.0 | 56 | 46 |
| 5.0-30.0 | 60 | 50 |

Note: 1. *Decreases with the logarithm of the frequency
 2. The lower limit shall apply at the transition frequencies
 3. The limit decreases in line with the logarithm of the frequency in the range of 0.15 to 0.50MHz.

4.1.2 TEST CONFIGURATION

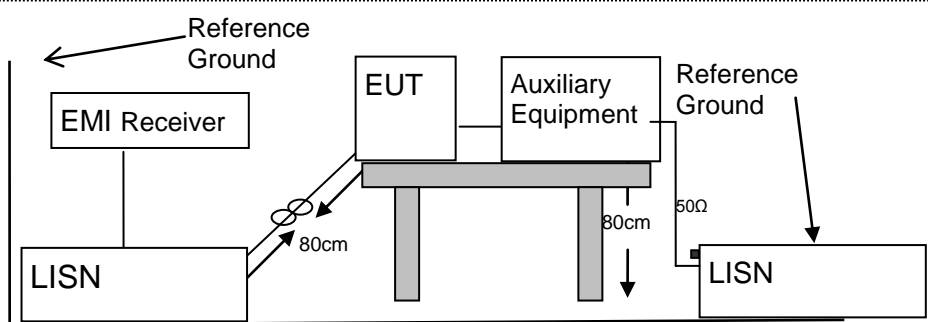

4.1.3 TEST PROCEDURE

According to the requirements in Section 13.1.4.1 of ANSI C63.10-2013 Conducted emissions the EUT measured in the frequency range between 0.15 MHz and 30 MHz using CISPR Quasi-Peak and average detector mode.

1. The EUT was placed 0.4 meter from the conducting wall of the shielding room.
2. The EUT was placed on a table which is 0.8m above ground plane.
3. Connect EUT to the power mains through a line impedance stabilization network (LISN). All other support equipments powered from additional LISN(s). The LISN provide 50 Ohm/ 50uH of coupling impedance for the measuring instrument.
4. Interconnecting cables that hang closer than 40 cm to the ground plane shall be folded back and forth in the center forming a bundle 30 to 40cm long.
5. I/O cables that are not connected to a peripheral shall be bundled in the center. The end of the cable may be terminated, if required, using the correct terminating impedance. The overall length shall not exceed 1 m.
6. LISN at least 80 cm from nearest part of EUT chassis.
7. The frequency range from 150KHz to 30MHz was searched.
8. Set the test-receiver system to Peak Detect Function and specified bandwidth(IF bandwidth=9KHz) with Maximum Hold Mode
9. For the actual test configuration, please refer to the related Item –EUT Test Photos.

4.1.4 TEST RESULT

| | | | |
|----------------|----------------------------------|---------------------|--------|
| EUT : | ECO Hygiene Micro-Station | Model Name : | ECO-02 |
| Temperature : | 26 °C | Relative Humidity : | 54% |
| Pressure : | 1010hPa | Phase : | L |
| Test Voltage : | DC 12V from Adapter AC 120V/60Hz | Test Mode : | Mode 1 |

| Frequency (MHz) | Reading Level (dBμV) | Correct Factor (dB) | Measure-ment (dBμV) | Limits (dBμV) | Margin (dB) | Remark |
|-----------------|----------------------|---------------------|---------------------|---------------|-------------|--------|
| 0.2059 | 35.69 | 9.55 | 45.24 | 63.37 | -18.13 | QP |
| 0.2059 | 16.56 | 9.55 | 26.11 | 53.37 | -27.26 | AVG |
| 0.262 | 29.93 | 9.54 | 39.47 | 61.36 | -21.89 | QP |
| 0.262 | 12.16 | 9.54 | 21.7 | 51.36 | -29.66 | AVG |
| 0.534 | 28.21 | 9.55 | 37.76 | 56 | -18.24 | QP |
| 0.534 | 25.71 | 9.55 | 35.26 | 46 | -10.74 | AVG |
| 1.07 | 24.87 | 9.56 | 34.43 | 56 | -21.57 | QP |
| 1.07 | 20.87 | 9.56 | 30.43 | 46 | -15.57 | AVG |
| 4.1939 | 19.41 | 9.61 | 29.02 | 56 | -26.98 | QP |
| 4.1939 | 10.43 | 9.61 | 20.04 | 46 | -25.96 | AVG |
| 18.9378 | 15.75 | 9.91 | 25.66 | 60 | -34.34 | QP |
| 18.9378 | 6.3 | 9.91 | 16.21 | 50 | -33.79 | AVG |

Remark:

1. All readings are Quasi-Peak and Average values.
2. Factor = Insertion Loss + Cable Loss.

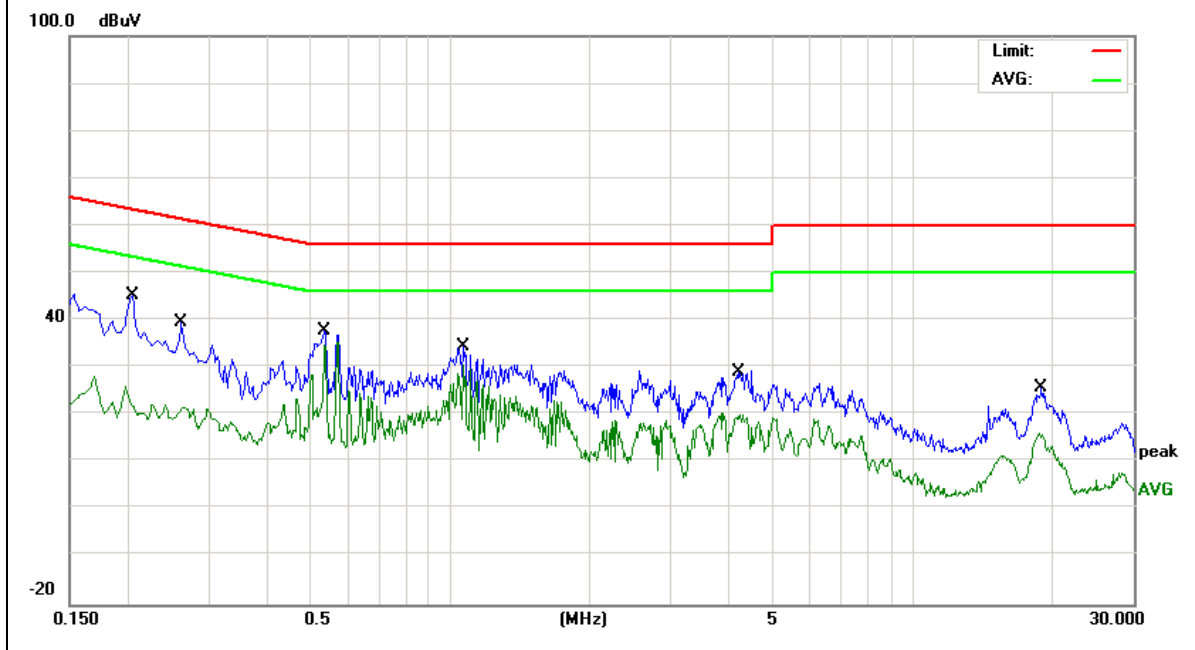

| | | | |
|----------------|----------------------------------|---------------------|--------|
| EUT : | ECO Hygiene Micro-Station | Model Name : | ECO-02 |
| Temperature : | 26 °C | Relative Humidity : | 54% |
| Pressure : | 1010hPa | Phase : | N |
| Test Voltage : | DC 12V from Adapter AC 120V/60Hz | Test Mode : | Mode 1 |

| Frequency (MHz) | Reading Level (dBμV) | Correct Factor (dB) | Measurement (dBμV) | Limits (dBμV) | Margin (dB) | Remark |
|-----------------|----------------------|---------------------|--------------------|---------------|-------------|--------|
| 0.162 | 35.53 | 9.55 | 45.08 | 65.36 | -20.28 | QP |
| 0.162 | 21.58 | 9.55 | 31.13 | 55.36 | -24.23 | AVG |
| 0.502 | 30.06 | 9.54 | 39.6 | 56 | -16.4 | QP |
| 0.502 | 22.79 | 9.54 | 32.33 | 46 | -13.67 | AVG |
| 0.538 | 37.13 | 9.54 | 46.67 | 56 | -9.33 | QP |
| 0.538 | 29.74 | 9.54 | 39.28 | 46 | -6.72 | AVG |
| 0.5699 | 30.17 | 9.54 | 39.71 | 56 | -16.29 | QP |
| 0.5699 | 25.19 | 9.54 | 34.73 | 46 | -11.27 | AVG |
| 2.2139 | 21.29 | 9.57 | 30.86 | 56 | -25.14 | QP |
| 2.2139 | 11.88 | 9.57 | 21.45 | 46 | -24.55 | AVG |
| 18.5418 | 27.16 | 9.87 | 37.03 | 60 | -22.97 | QP |
| 18.5418 | 19.51 | 9.87 | 29.38 | 50 | -20.62 | AVG |

Remark:

1. All readings are Quasi-Peak and Average values.
2. Factor = Insertion Loss + Cable Loss.

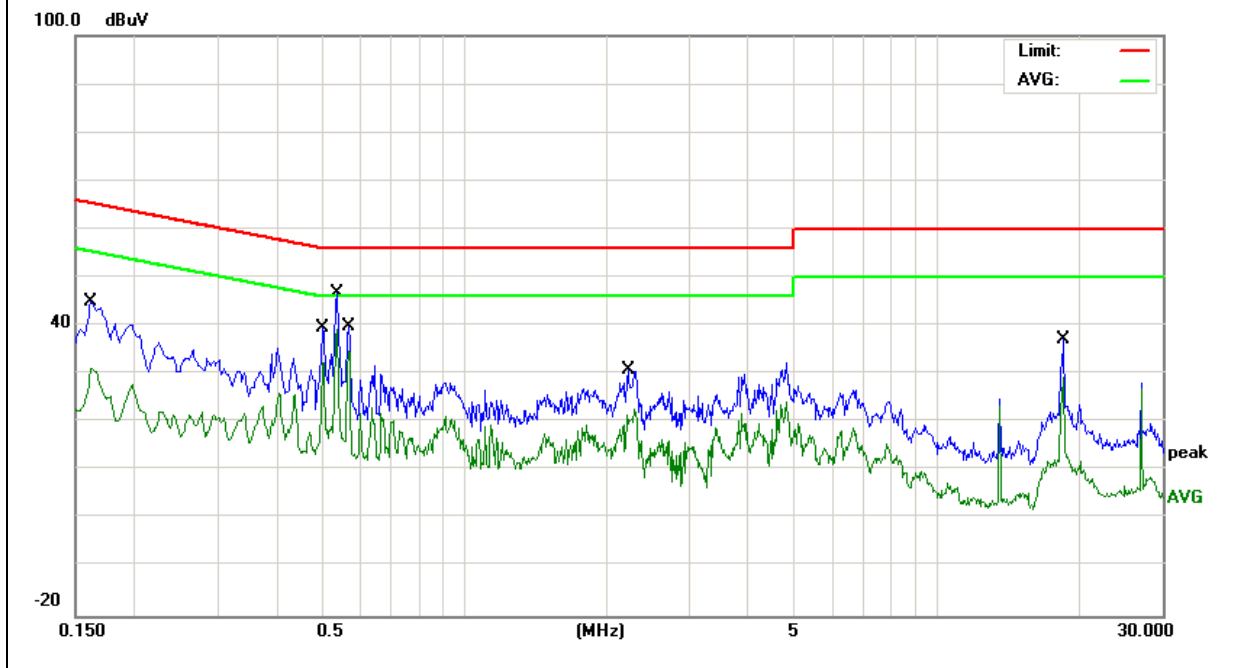

4.2 RADIATED EMISSION MEASUREMENT

4.2.1 Radiated Emission Limits (FCC 15.209)

| Frequencies (MHz) | Field Strength (micorvolts/meter) | Measurement Distance (meters) |
|-------------------|-----------------------------------|-------------------------------|
| 0.009~0.490 | 2400/F(KHz) | 300 |
| 0.490~1.705 | 24000/F(KHz) | 30 |
| 1.705~30.0 | 30 | 30 |
| 30~88 | 100 | 3 |
| 88~216 | 150 | 3 |
| 216~960 | 200 | 3 |
| Above 960 | 500 | 3 |

Note:

- (1) The tighter limit applies at the band edges.
- (2) Emission level (dBuV/m)=20log Emission level (uV/m).

According to FCC Part 15.247(d): radiated emissions which fall in the restricted bands, as defined in §15.205(a) must also comply with the radiated emission limits specified in §15.209(a) (see §15.205(c)).

According to FCC Part15.205, Restricted bands

| MHz | MHz | MHz | GHz |
|-------------------|---------------------|---------------|-------------|
| 0.090-0.110 | 16.42-16.423 | 399.9-410 | 4.5-5.15 |
| 10.495-0.505 | 16.69475-16.69525 | 608-614 | 5.35-5.46 |
| 2.1735-2.1905 | 16.80425-16.80475 | 960-1240 | 7.25-7.75 |
| 4.125-4.128 | 25.5-25.67 | 1300-1427 | 8.025-8.5 |
| 4.17725-4.17775 | 37.5-38.25 | 1435-1626.5 | 9.0-9.2 |
| 4.20725-4.20775 | 73-74.6 | 1645.5-1646.5 | 9.3-9.5 |
| 6.215-6.218 | 74.8-75.2 | 1660-1710 | 10.6-12.7 |
| 6.26775-6.26825 | 123-138 | 2200-2300 | 14.47-14.5 |
| 8.291-8.294 | 149.9-150.05 | 2310-2390 | 15.35-16.2 |
| 8.362-8.366 | 156.52475-156.52525 | 2483.5-2500 | 17.7-21.4 |
| 8.37625-8.38675 | 156.7-156.9 | 2690-2900 | 22.01-23.12 |
| 8.41425-8.41475 | 162.0125-167.17 | 3260-3267 | 23.6-24.0 |
| 12.29-12.293 | 167.72-173.2 | 3332-3339 | 31.2-31.8 |
| 12.51975-12.52025 | 240-285 | 3345.8-3358 | 36.43-36.5 |
| 12.57675-12.57725 | 322-335.4 | 3600-4400 | (2) |
| 13.36-13.41 | | | |

LIMITS OF RADIATED EMISSION MEASUREMENT (FCC 15.225)

- (a) The field strength of any emissions within the band 13.553-13.567 MHz shall not exceed 15,848 microvolts/meter at 30 meters, equal to 124dBuV/m at 3 meters.
- (b) Within the bands 13.410-13.553 MHz and 13.567-13.710 MHz, the field strength of any emissions shall not exceed 334 microvolts/meter at 30 meters, equal to 90.5dBuV/m at 3 meters.
- (c) Within the bands 13.110-13.410 MHz and 13.710-14.010 MHz the field strength of any emissions shall not exceed 106 microvolts/meter at 30 meters, equal to 80.5dBuV/m at 3 meters..
- (d) The field strength of any emissions appearing outside of the 13.110-14.010 MHz band shall not exceed the general radiated emission limits in § 15.209.

| Spectrum Parameter | Setting |
|---------------------------------------|-----------------------|
| Attenuation | Auto |
| Start Frequency | 1000 MHz |
| Stop Frequency | 10th carrier harmonic |
| RB / VB (emission in restricted band) | 1MHz / 1MHz for Peak |

| Receiver Parameter | Setting |
|------------------------|----------------------------------|
| Attenuation | Auto |
| Start ~ Stop Frequency | 9kHz~150kHz / RB 200Hz for QP |
| Start ~ Stop Frequency | 150kHz~30MHz / RB 9kHz for QP |
| Start ~ Stop Frequency | 30MHz~1000MHz / RB 120kHz for QP |

4.2.2 TEST PROCEDURE

- a. The measuring distance of at 3 m shall be used for measurements at frequency up to 1GHz And above 1GHz,
- b. The EUT was placed on the top of a rotating table 0.8 meters above the ground at a 3m meter. The table was rotated 360 degrees to determine the position of the highest radiation.
- c. The height of the equipment or of the substitution antenna shall be 0.8 m; the height of the test antenna shall vary between 1 m to 4 m.
- d. The initial step in collecting conducted emission data is a spectrum analyzer peak detector mode pre-scanning the measurement frequency range. Significant peaks are then marked and then Quasi Peak detector mode re-measured.
- e. If the Peak Mode measured value compliance with and lower than Quasi Peak Mode Limit, the EUT shall be deemed to meet QP Limits and then no additional QP Mode measurement performed.
- f. For the actual test configuration, please refer to the related Item –EUT Test Photos.

Note:

Both horizontal and vertical antenna polarities were tested and performed pretest to three orthogonal axis. The worst case emissions were reported

4.2.3 DEVIATION FROM TEST STANDARD

No deviation

4.2.4 TEST SETUP

(A) Radiated Emission Test-Up Frequency Below 30MHz

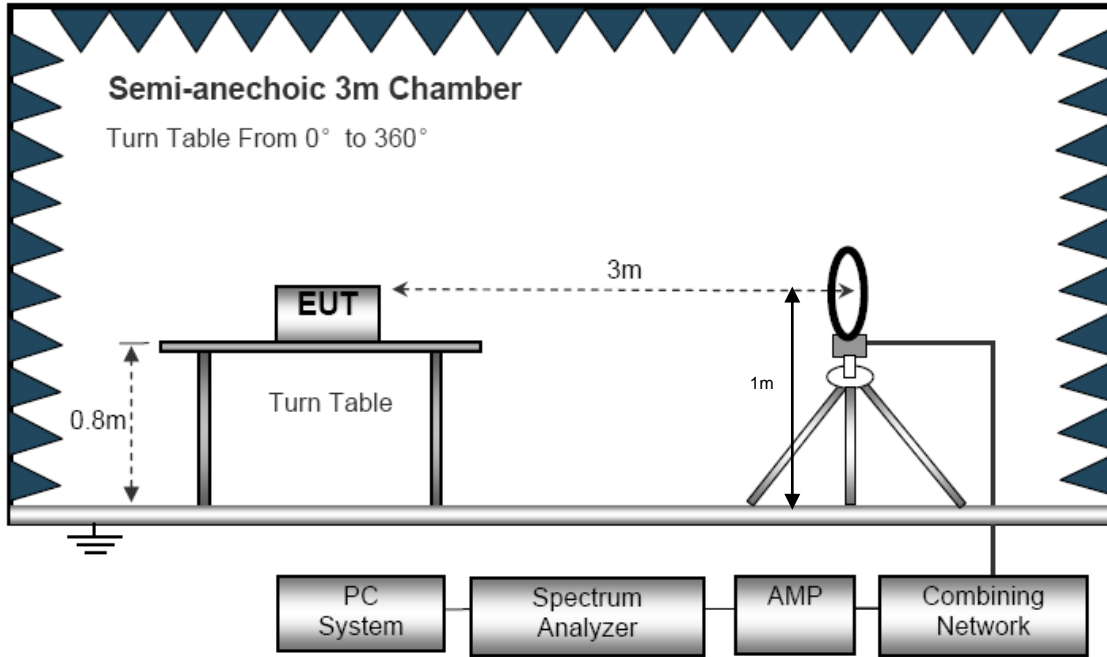

(B) Radiated Emission Test-Up Frequency 30MHz~1GHz

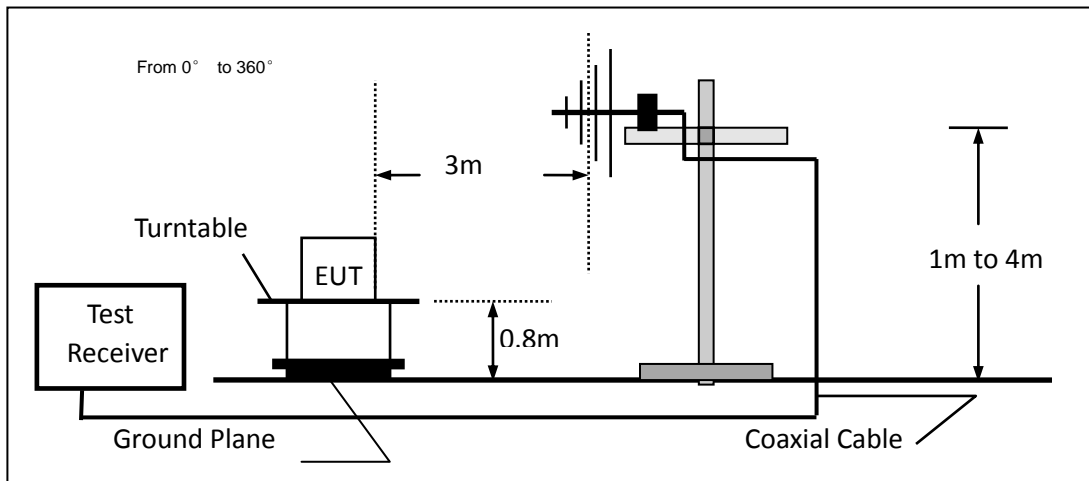

4.2.5 TEST RESULTS (BELOW 30MHz)

| | | | |
|---------------|---------------------------|---------------------|--------|
| EUT : | ECO Hygiene Micro-Station | Model Name. : | ECO-02 |
| Temperature : | 20 °C | Relative Humidity : | 54% |
| Pressure : | 1010 hPa | Test Voltage : | DC 12V |
| Test Mode : | TX-13.56MHz | | |

Measurement Plot (Polarity: X):

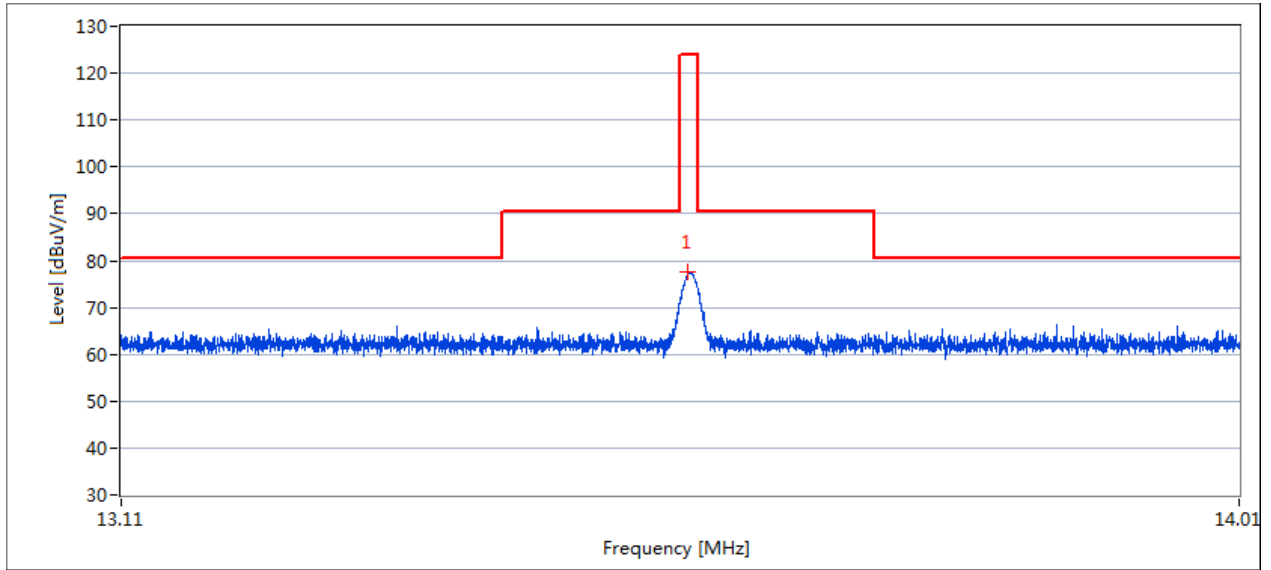

Measurement Result:

| Frequency MHz | Pre-scan Level MaxPeak dBuV/m | Final Test Level MaxPeak dBuV/m | Limit MaxPeak dBuV/m | Margin dB |
|---------------|-------------------------------|---------------------------------|----------------------|-----------|
| 13.559 | 77.5 | 77.4 | 124.0 | 46.6 |

Measurement Plot (Polarity: Y):

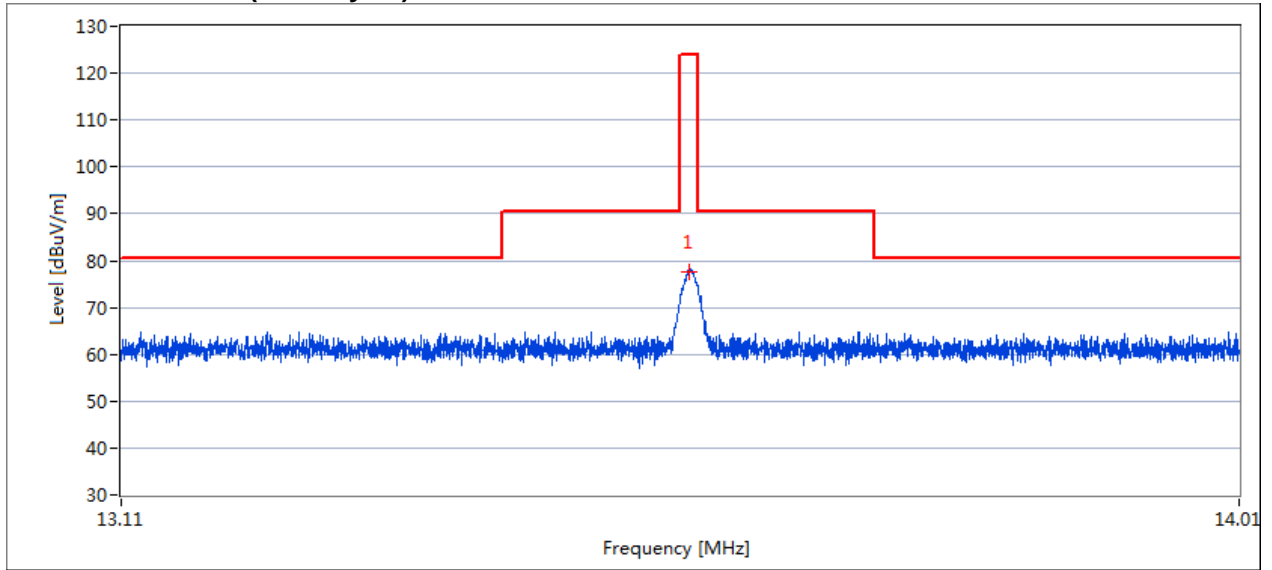

Measurement Result:

| Frequency MHz | Pre-scan Level MaxPeak dBuV/m | Final Test Level MaxPeak dBuV/m | Limit MaxPeak dBuV/m | Margin dB |
|---------------|-------------------------------|---------------------------------|----------------------|-----------|
| 13.560 | 77.6 | 78.0 | 124.0 | 46.0 |

Measurement Plot (Polarity: Z):

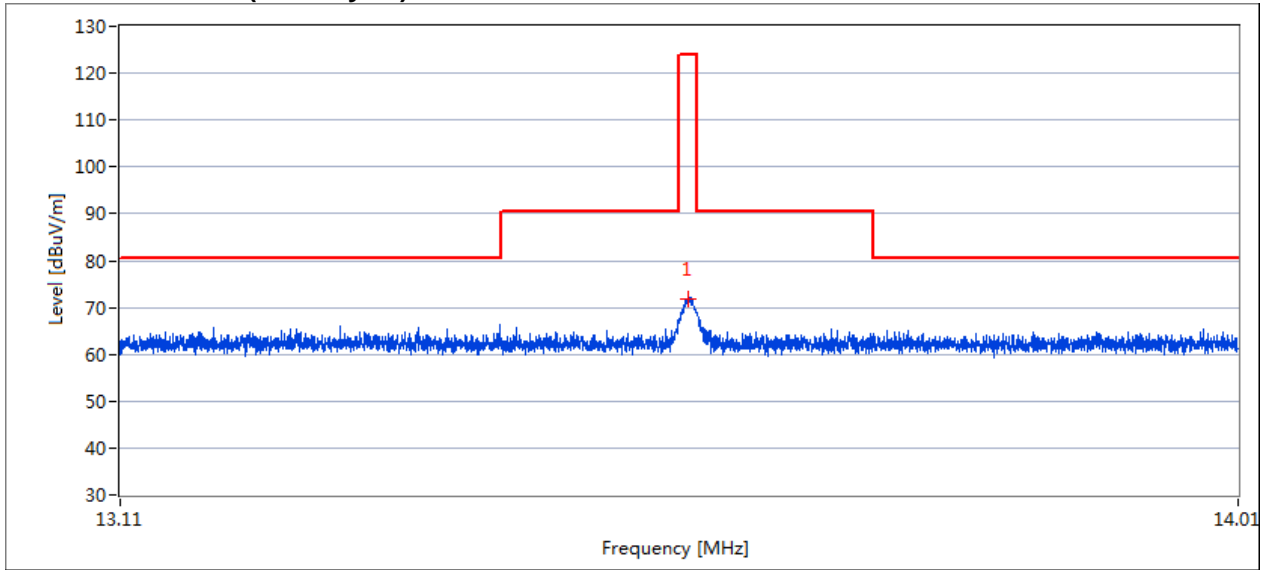

Measurement Result:

| Frequency MHz | Pre-scan Level MaxPeak dBuV/m | Final Test Level MaxPeak dBuV/m | Limit MaxPeak dBuV/m | Margin dB |
|---------------|-------------------------------|---------------------------------|----------------------|-----------|
| 13.560 | 71.8 | 71.9 | 124.0 | 52.1 |

Spurious emissions at 9KHz~13.110MHz & 14.010MHz~30MHz

| Frequency | Ant. Pol. | Emission Level | Limits | Margin | Detector |
|-----------|-----------|----------------|------------|--------|----------|
| | | (dBuV/m) | | | |
| (MHz) | dBuV @3m | @3m | dBuV/m @3m | (dB) | |
| 0.057 | X | 43.15 | 112.488 | -69.34 | QP |
| 0.126 | X | 72.14 | 105.597 | -33.46 | QP |
| 0.754 | X | 42.13 | 73.712 | -31.58 | QP |
| 4.156 | X | 36.56 | 69.542 | -32.98 | QP |
| 12.296 | X | 38.99 | 69.542 | -30.55 | QP |

Note:

Below 30MHz, Pre-test the X, Y, Z axis to find X axis is worst case, so only record X axis test data.

X: Field strength which this device generates since the position of the charging coil and loop antenna differ by 0 degrees.

Y: Field strength which this device generates since the position of the charging coil and loop antenna differ by 90 degrees.

Z: Field strength which this device generates since the position of the charging coil and loop antenna differ by 180 degrees

4.2.6 TEST RESULTS (BETWEEN 30 – 1000 MHZ)

| | | | |
|---------------|---------------------------|---------------------|------------|
| EUT : | ECO Hygiene Micro-Station | Model Name : | ECO-02 |
| Temperature : | 20 °C | Relative Humidity : | 54% |
| Pressure : | 1010 hPa | Test Voltage : | DC 12V |
| Test Mode : | TX | Polarization : | Horizontal |

| Freq. (MHz) | Reading (dBµV/m) | Factor (dB) | Measurement (dBµV/m) | Limit (dBµV/m) | Over (dB) | Detector |
|-------------|------------------|-------------|----------------------|----------------|-----------|----------|
| 135.5062 | 20.13 | 12.49 | 32.62 | 43.5 | -10.88 | peak |
| 271.3245 | 26.46 | 14.34 | 40.8 | 46 | -5.2 | peak |
| 434.0651 | 24.51 | 18.41 | 42.92 | 46 | -3.08 | peak |
| 556.7744 | 20 | 22.44 | 42.44 | 46 | -3.56 | peak |
| 760.7036 | 17.83 | 24.93 | 42.76 | 46 | -3.24 | peak |
| 869.1301 | 16.49 | 25.88 | 42.37 | 46 | -3.63 | peak |

Remark:

Factor = Antenna Factor + Cable Loss.

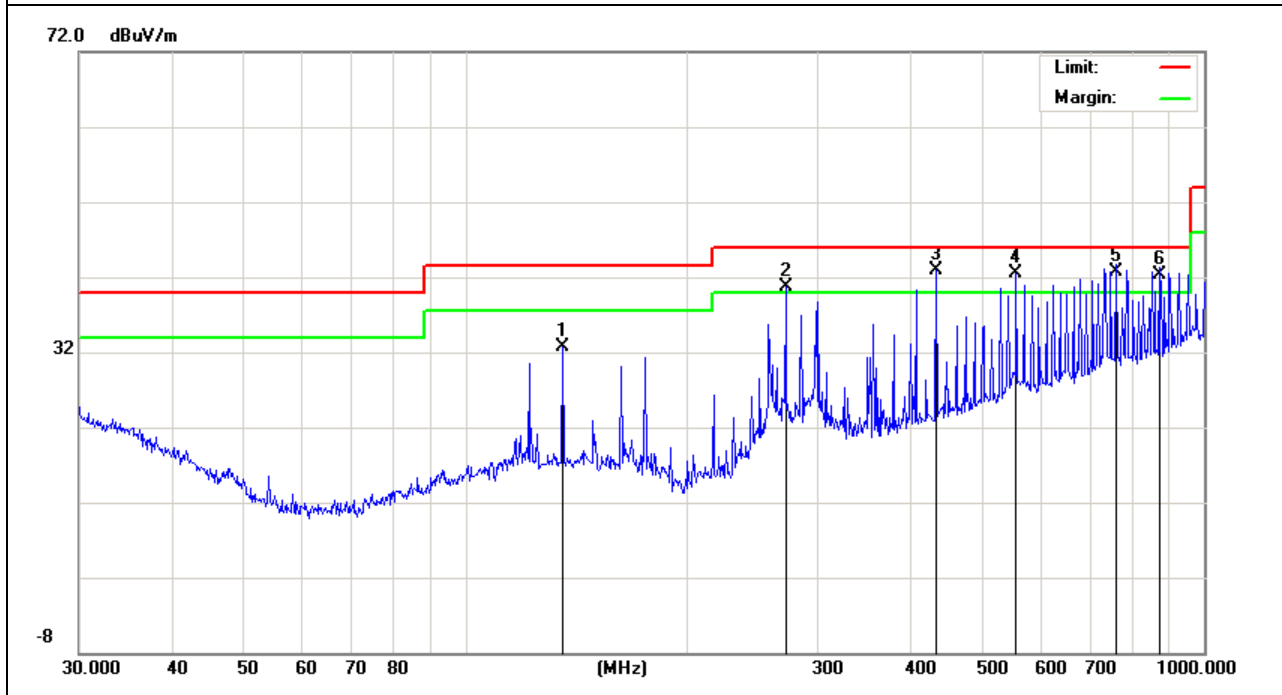

| | | | |
|---------------|---------------------------|---------------------|----------|
| EUT : | ECO Hygiene Micro-Station | Model Name : | ECO-02 |
| Temperature : | 20 °C | Relative Humidity : | 54% |
| Pressure : | 1010 hPa | Test Voltage : | DC 12V |
| Test Mode : | TX | Polarization : | Vertical |

| Freq. (MHz) | Reading (dB μ V/m) | Factor (dB) | Measurement (dB μ V/m) | Limit (dB μ V/m) | Over (dB) | Detector |
|----------------|---------------------------|----------------|-------------------------------|-------------------------|--------------|----------|
| 121.9755 | 21.58 | 12.32 | 33.9 | 43.5 | -9.6 | QP |
| 271.3246 | 24.31 | 14.34 | 38.65 | 46 | -7.35 | QP |
| 556.7744 | 20.03 | 22.44 | 42.47 | 46 | -3.53 | QP |
| 734.4913 | 16.63 | 25.15 | 41.78 | 46 | -4.22 | QP |
| 851.0353 | 16.3 | 26.22 | 42.52 | 46 | -3.48 | QP |
| 925.7563 | 15.49 | 27.51 | 43 | 46 | -3 | QP |

Remark:
Factor = Antenna Factor + Cable Loss.

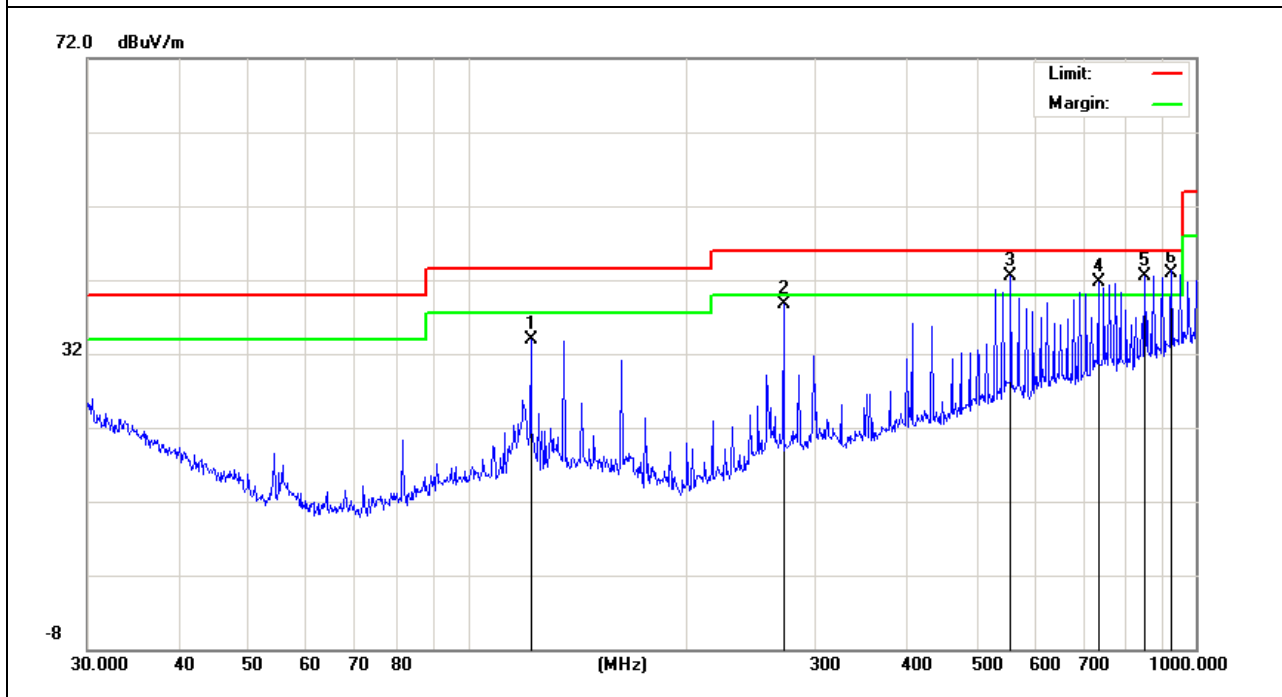

5. BANDWIDTH TEST

5.1 TEST PROCEDURE

1. The transmitter output (antenna port) was connected to the spectrum analyzer in peak mode.
2. 20dB Bandwidth the resolution bandwidth of 1 kHz and the video bandwidth of 1 kHz were used.
3. Measured the spectrum width with power higher than 20dB below carrier.

5.2 DEVIATION FROM STANDARD

15.215

(c) Intentional radiators operating under the alternative provisions to the general emission limits, as contained in §§15.217 through 15.257 and in subpart E of this part, must be designed to ensure that the 20 dB bandwidth of the emission, or whatever bandwidth may otherwise be specified in the specific rule section under which the equipment operates, is contained within the frequency band designated in the rule section under which the equipment is operated

FCC Part15.225

Operation within the band 13.553MHz–13.567MHz

5.3 TEST SETUP



5.4 TEST RESULTS

| | | | |
|---------------|---------------------------|---------------------|--------|
| EUT : | ECO Hygiene Micro-Station | Model Name : | ECO-02 |
| Temperature : | 26 °C | Relative Humidity : | 54% |
| Pressure : | 1020 hPa | Test Power : | DC 12V |
| Test Mode : | TX | | |

| Test Channel | Frequency (MHz) | 20 dBc Bandwidth (kHz) |
|--------------|-----------------|------------------------|
| CH01 | 13.56 | 2.46 |

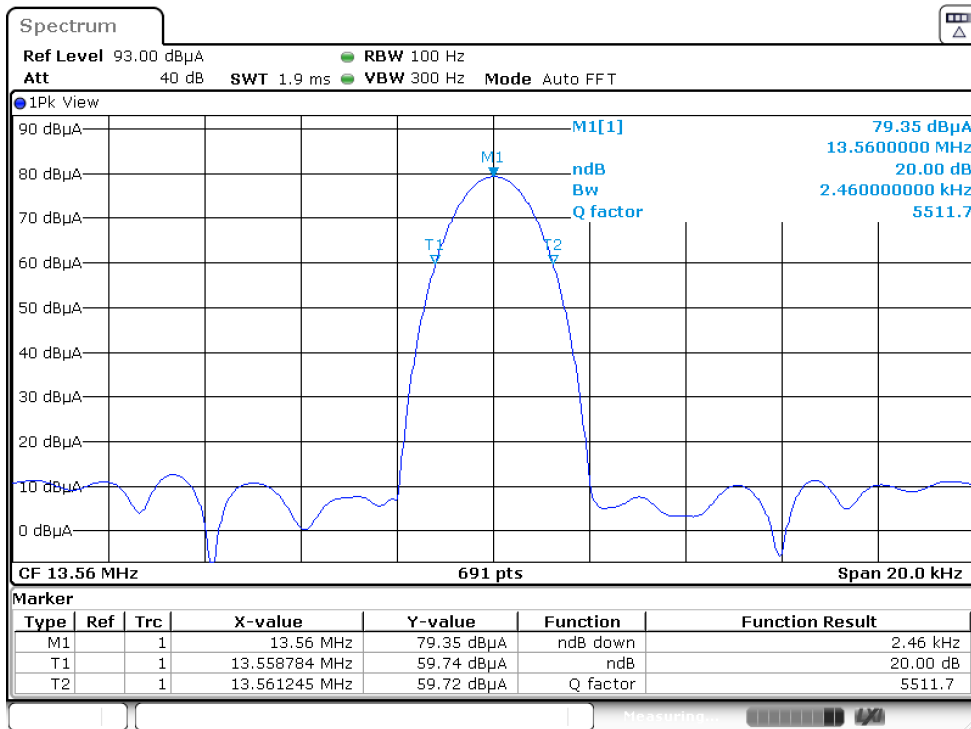

6. FREQUENCY TOLERANCE

6.1 Requirement:

Test FCC Part15.225

Requirement:

Test Method: ANSI C63.10:2013

Requirement: The frequency tolerance of the carrier signal shall be maintained within +/- 0.01% of the operating frequency over a temperature variation of -20 degrees to +50 degrees C at normal supply voltage, and for a variation in the primary supply voltage from 85% to 115% of the rated supply voltage at a temperature of 20 degrees C. For battery operated equipment, the equipment tests shall be performed using a new battery.

6.2 Test Procedure

- 1.The EUT was placed on a turn table which is 0.8m above ground plane.
- 2.Set EUT as normal operation
- 3.Set SPA Center Frequency = fundamental frequency, RBW, VBW= 10kHz, Span =100kHz.
- 4.Set SPA Max hold. Mark peak.

Test Result

| Power Supply | Temperature (°C) | Measured Frequency (MHz) | Frequency Error (MHz) | Result (ppm) | Part 15.225 Limit |
|--------------|------------------|--------------------------|-----------------------|--------------|-------------------|
| DC 13.2V | -20 | 13.56011 | 0.00011 | 8.11 | +/- 0.01%(100ppm) |
| | 20 | 13.56015 | 0.00015 | 11.06 | +/- 0.01%(100ppm) |
| | 50 | 13.56016 | 0.00016 | 11.80 | +/- 0.01%(100ppm) |
| DC 12V | -20 | 13.56017 | 0.00017 | 12.54 | +/- 0.01%(100ppm) |
| | 20 | 13.56013 | 0.00013 | 9.59 | +/- 0.01%(100ppm) |
| | 50 | 13.56016 | 0.00016 | 11.80 | +/- 0.01%(100ppm) |
| DC 10.8V | -20 | 13.56014 | 0.00014 | 10.32 | +/- 0.01%(100ppm) |
| | 20 | 13.56015 | 0.00015 | 11.06 | +/- 0.01%(100ppm) |
| | 50 | 13.56017 | 0.00017 | 12.54 | +/- 0.01%(100ppm) |

END REPORT