



Shenzhen Huaxia Testing Technology Co., Ltd.

1F., Block A of Tongsheng Technology Building, Huahui Road, Dalang Street, Longhua District, Shenzhen, China

Telephone: +86-755-26648640

Fax: +86-755-26648637

Website: www.cqa-cert.com

Report Template Version: V05

Report Template Revision Date: 2021-11-03

TEST REPORT

Report No.: CQASZ20240801545E-02
Applicant: SHENZHEN XINWU TECHNOLOGY LIMITED
Address of Applicant: Floor 6, Building 2, Chungu Science park, Meisheng Huigu Science Park, 83 Dabao Road, Baoan District, Shenzhen
Equipment Under Test (EUT):
Product: WIFI Visualizable Smart DoorBell
Model No.: XW133-X1, XW133-X2, XW133-X3, XW133-X4, XW133-X5, XW133-X6, XW133-X7, XW133-X8, XW133-X9, XW133-X10, XW133-D10
Test Model No.: XW133-X9
Brand Name: N/A
FCC ID: 2AW97-X9
Standards: 47 CFR Part 15, Subpart C
KDB558074 D01 15.247 Meas Guidance v05r02
ANSI C63.10:2013
Date of Receipt: 2024-08-01
Date of Test: 2024-08-01 to 2024-08-28
Date of Issue: 2024-09-05
Test Result : **PASS***

*In the configuration tested, the EUT complied with the standards specified above

Tested By: Lewis Zhou
(Lewis Zhou)

Reviewed By: Timo Lei
(Timo Lei)

Approved By: Alex
(Alex Wang)



The test report is effective only with both signature and specialized stamp, The result(s) shown in this report refer only to the sample(s) tested. Without written approval of CQA, this report can't be reproduced except in full.

1 Version

Revision History Of Report

Report No.	Version	Description	Issue Date
CQASZ20240801545E-02	Rev.01	Initial report	2024-09-05

2 Test Summary

Test Item	Test Requirement	Test method	Result
Antenna Requirement	47 CFR Part 15.203	N/A	PASS
AC Power Line Conducted Emission	47 CFR Part 15.207	ANSI C63.10-2013	PASS
Conducted Peak & Average Output Power	47 CFR Part 15.247	ANSI C63.10-2013	PASS
6dB Occupied Bandwidth	47 CFR Part 15.247	ANSI C63.10-2013	PASS
Power Spectral Density	47 CFR Part 15.247	ANSI C63.10-2013	PASS
Band-edge for RF Conducted Emissions	47 CFR Part 15.247	ANSI C63.10-2013	PASS
RF Conducted Spurious Emissions	47 CFR Part 15.247	ANSI C63.10-2013	PASS
Radiated Spurious Emissions	47 CFR Part 15.209	ANSI C63.10-2013	PASS
Restricted bands around fundamental frequency (Radiated Emission)	47 CFR Part 15.205/15.209	ANSI C63.10-2013	PASS

Remark:

The tested sample(s) and the sample information are provided by the client.

Tx: In this whole report Tx (or tx) means Transmitter.

Rx: In this whole report Rx (or rx) means Receiver.

RF: In this whole report RF means Radiated Frequency.

CH: In this whole report CH means channel.

Volt: In this whole report Volt means Voltage.

Temp: In this whole report Temp means Temperature.

Humid: In this whole report Humid means humidity.

Press: In this whole report Press means Pressure.

N/A: In this whole report not application

3 Contents

	Page
1 VERSION	2
2 TEST SUMMARY	3
3 CONTENTS	4
4 GENERAL INFORMATION	5
4.1 CLIENT INFORMATION	5
4.2 GENERAL DESCRIPTION OF EUT	5
4.3 PRODUCT SPECIFICATION SUBJECTIVE TO THIS STANDARD	5
4.4 TEST ENVIRONMENT AND MODE	7
4.5 DESCRIPTION OF SUPPORT UNITS	8
4.6 TEST LOCATION	8
4.7 TEST FACILITY	8
4.8 STATEMENT OF THE MEASUREMENT UNCERTAINTY	9
4.9 DEVIATION FROM STANDARDS	9
4.10 ABNORMALITIES FROM STANDARD CONDITIONS	9
4.11 OTHER INFORMATION REQUESTED BY THE CUSTOMER	9
4.12 EQUIPMENT LIST	10
5 TEST RESULTS AND MEASUREMENT DATA	11
5.1 ANTENNA REQUIREMENT	11
5.2 CONDUCTED EMISSIONS	12
5.3 CONDUCTED PEAK & AVERAGE OUTPUT POWER	16
<i>Test Result</i>	17
<i>Note:</i>	17
<i>When Duty cycle >98%, D.C.F is not required.</i>	17
<i>Test Graphs</i>	18
5.4 6DB OCCUPIED BANDWIDTH	22
<i>Test Result</i>	23
<i>Test Graphs</i>	24
5.5 POWER SPECTRAL DENSITY	28
<i>Test Result</i>	29
<i>Test Graphs</i>	30
5.6 BAND-EDGE FOR RF CONDUCTED EMISSIONS	34
<i>Test Result</i>	35
5.6.1 <i>Test Graphs</i>	36
5.7 RF CONDUCTED SPURIOUS EMISSIONS	39
<i>Test Result</i>	40
<i>Test Graphs</i>	41
5.8 RADIATED SPURIOUS EMISSIONS	51
5.8.1 <i>Radiated emission below 1GHz</i>	54
5.8.2 <i>Transmitter emission above 1GHz</i>	56
5.9 RESTRICTED BANDS AROUND FUNDAMENTAL FREQUENCY	62
6 PHOTOGRAPHS - EUT TEST SETUP	67
6.1 RADIATED SPURIOUS EMISSION	67
6.2 CONDUCTED EMISSION	68
7 PHOTOGRAPHS - EUT CONSTRUCTIONAL DETAILS	69

4 General Information

4.1 Client Information

Applicant:	SHENZHEN XINWU TECHNOLOGY LIMITED
Address of Applicant:	Floor 6, Building 2, Chungu Science park, Meisheng Huigu Science Park, 83 Dabao Road, Baoan District, Shenzhen
Manufacturer:	SHENZHEN XINWU TECHNOLOGY LIMITED
Address of Manufacturer:	Floor 6, Building 2, Chungu Science park, Meisheng Huigu Science Park, 83 Dabao Road, Baoan District, Shenzhen
Factory:	SHENZHEN XINWU TECHNOLOGY LIMITED
Address of Factory:	Floor 6, Building 2, Chungu Science park, Meisheng Huigu Science Park, 83 Dabao Road, Baoan District, Shenzhen

4.2 General Description of EUT

Product Name:	WIFI Visualizable Smart DoorBell
Model No.:	XW133-X1, XW133-X2, XW133-X3, XW133-X4, XW133-X5, XW133-X6, XW133-X7, XW133-X8, XW133-X9, XW133-X10, XW133-D10
Test Model No.:	XW133-X9
Trade Mark:	N/A
Software Version:	XW133-X9-P0_V1.0
Hardware Version:	XW133-X9-P0_V1.2
Power Supply:	Li-ion battery DC 3.7V 600mAh, Charge by DC 5V for adapter
EUT Supports Radios application:	2.4GHz: Wi-Fi: 802.11b/g/n(HT20): 2412MHz~2462MHz
Simultaneous Transmission	<input type="checkbox"/> Simultaneous TX is supported and evaluated in this report. <input checked="" type="checkbox"/> Simultaneous TX is not supported.

4.3 Product Specification subjective to this standard

Operation Frequency:	IEEE 802.11b/g/n(HT20): 2412MHz to 2462MHz
Channel Numbers:	IEEE 802.11b/g, IEEE 802.11n HT20: 11 Channels
Channel Separation:	5MHz
Type of Modulation:	IEEE for 802.11b: DSSS(CCK,DQPSK,DBPSK) IEEE for 802.11g : OFDM(64QAM, 16QAM, QPSK, BPSK) IEEE for 802.11n(HT20) : OFDM (64QAM, 16QAM, QPSK, BPSK)
Transfer Rate:	IEEE for 802.11b: 1Mbps/2Mbps/5.5Mbps/11Mbps IEEE for 802.11g : 6Mbps/9Mbps/12Mbps/18Mbps/24Mbps/36Mbps/48Mbps/54Mbps IEEE for 802.11n(HT20) : 6.5Mbps/13Mbps/19.5Mbps/26Mbps/39Mbps/52Mbps/58.5Mbps/65Mbps
Product Type:	<input checked="" type="checkbox"/> Mobile <input type="checkbox"/> Portable
Test Software of EUT:	Beken WIFI Test Tool V1.7.2
Antenna Type:	PCB antenna
Antenna Gain:	1.85dBi

Operation Frequency each of channel(802.11b/g/n HT20)							
Channel	Frequency	Channel	Frequency	Channel	Frequency	Channel	Frequency
1	2412MHz	4	2427MHz	7	2442MHz	10	2457MHz
2	2417MHz	5	2432MHz	8	2447MHz	11	2462MHz
3	2422MHz	6	2437MHz	9	2452MHz		

Note:

In section 15.31(m), regards to the operating frequency range over 10 MHz, the Lowest frequency, the middle frequency, and the highest frequency of channel were selected to perform the test, and the selected channel see below:

For 802.11b/g/n (HT20):

Channel	Frequency
The Lowest channel	2412MHz
The Middle channel	2437MHz
The Highest channel	2462MHz

Note:

Software provided by client enabled the EUT to transmit and receive data at lowest, middle and highest channel individually.

4.4 Test Environment and Mode

Operating Environment:	
Radiated Emissions:	
Temperature:	25.3 °C
Humidity:	55 % RH
Atmospheric Pressure:	1009 mbar
Conducted Emissions:	
Temperature:	25.6 °C
Humidity:	60 % RH
Atmospheric Pressure:	1009 mbar
Radio conducted item test (RF Conducted test room):	
Temperature:	25.5 °C
Humidity:	52 % RH
Atmospheric Pressure:	1009 mbar
Test mode:	
Transmitting mode:	EUT is set in RF test mode in all supported modulation types, bandwidth and data rate, etc.

Run Software:

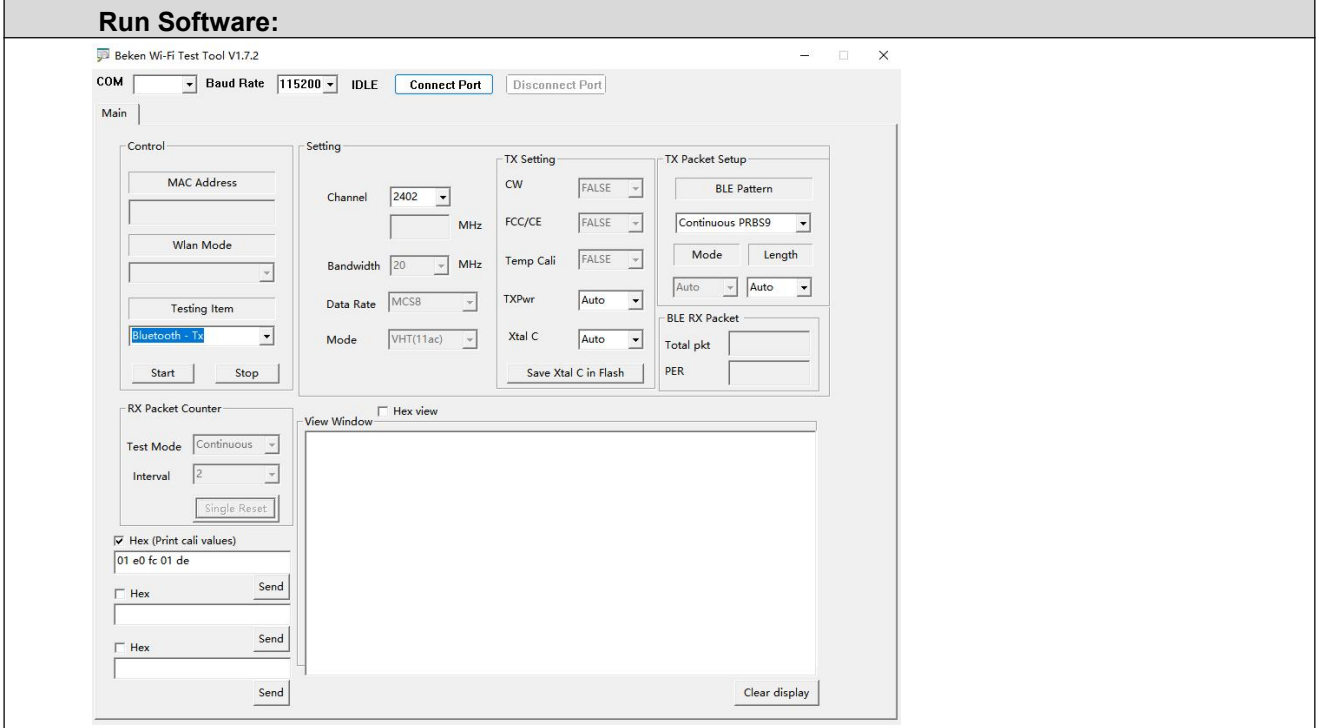

The screenshot shows the Beken Wi-Fi Test Tool V1.7.2 interface. At the top, there are controls for COM port, Baud Rate (115200), and IDLE status. The main area is divided into several sections:

- Control:** Includes fields for MAC Address, Wlan Mode, and Testing Item (set to Bluetooth Tx). Start and Stop buttons are present.
- Setting:** Includes Channel (2402 MHz), Bandwidth (20 MHz), Data Rate (MCS8), and Mode (VHT(11ac)).
- TX Setting:** Includes CW, FCC/CE, Temp Cali, TXPwr, and Xtal C, all set to FALSE or Auto.
- TX Packet Setup:** Includes BLE Pattern (Continuous PRBS9), Mode, and Length, both set to Auto.
- BLE RX Packet:** Includes Total pkt and PER fields.
- RX Packet Counter:** Includes Test Mode (Continuous), Interval (2), and a Single Reset button.
- View Window:** A large empty area for displaying test results, with a Hex view checkbox and a Clear display button.

4.5 Description of Support Units

The EUT has been tested with associated equipment below.

1) Support equipment

Description	Manufacturer	Model No.	Certification	Supplied by
/	/	/	/	/

2) Cable

Cable No.	Description	Manufacturer	Cable Type/Length	Supplied by
/	/	/	/	/

4.6 Test Location

All tests were performed at:

Shenzhen Huaxia Testing Technology Co., Ltd.

1F., Block A of Tongsheng Technology Building, Huahui Road, Dalang Street, Longhua New District, Shenzhen, Guangdong, China

4.7 Test Facility

The test facility is recognized, certified, or accredited by the following organizations:

• **A2LA (Certificate No. 4742.01)**

Shenzhen Huaxia Testing Technology Co., Ltd., Shenzhen EMC Laboratory is accredited by the American Association for Laboratory Accreditation(A2LA). Certificate No. 4742.01.

• **FCC Registration No.: 522263**

Shenzhen Huaxia Testing Technology Co., Ltd., Shenzhen EMC Laboratory has been registered and fully described in a report filed with the (FCC) Federal Communications Commission. The acceptance letter from the FCC is maintained in our files. Registration No.:522263

4.8 Statement of the measurement uncertainty

The data and results referenced in this document are true and accurate.

The reader is cautioned that there may be errors within the calibration limits of the equipment and facilities.

The measurement uncertainty was calculated for all measurements listed in this test report acc. to CISPR 16 - 4 „Specification for radio disturbance and immunity measuring apparatus and methods – Part 4: Uncertainty in EMC Measurements“ and is documented in the **Shenzhen Huaxia Testing Technology Co., Ltd.** quality system acc. to DIN EN ISO/IEC 17025.

Furthermore, component and process variability of devices similar to that tested may result in additional deviation. The manufacturer has the sole responsibility of continued compliance of the device.

Hereafter the best measurement capability for CQA laboratory is reported:

No.	Item	Uncertainty	Notes
1	Radiated Emission (Below 1GHz)	5.12dB	(1)
2	Radiated Emission (Above 1GHz)	4.60dB	(1)
3	Conducted Disturbance (0.15~30MHz)	3.34dB	(1)
4	Radio Frequency	3×10^{-8}	(1)
5	Duty cycle	0.6 %.	(1)
6	Occupied Bandwidth	1.1%	(1)
7	RF conducted power	0.86dB	(1)
8	RF power density	0.74	(1)
9	Conducted Spurious emissions	0.86dB	(1)
10	Temperature test	0.8°C	(1)
11	Humidity test	2.0%	(1)
12	Supply voltages	0.5 %.	(1)
13	Frequency Error	5.5 Hz	(1)

(1)This uncertainty represents an expanded uncertainty expressed at approximately the 95% confidence level using a coverage factor of k=2.

4.9 Deviation from Standards

None.

4.10 Abnormalities from Standard Conditions

None.

4.11 Other Information Requested by the Customer

None.

4.12 Equipment List

Test Equipment	Manufacturer	Model No.	Instrument No.	Calibration Date	Calibration Due Date
EMI Test Receiver	R&S	ESR7	CQA-005	2023/09/08	2024/09/07
Spectrum analyzer	R&S	FSU26	CQA-038	2023/09/08	2024/09/07
Spectrum analyzer	R&S	FSU40	CQA-075	2023/09/08	2024/09/07
Preamplifier	MITEQ	AFS4-00010300-18-10P-4	CQA-035	2023/09/08	2024/09/07
Preamplifier	MITEQ	AMF-6D-02001800-29-20P	CQA-036	2023/09/08	2024/09/07
Preamplifier	EMCI	EMC184055SE	CQA-089	2023/09/08	2024/09/07
Loop antenna	Schwarzbeck	FMZB1516	CQA-060	2021/09/16	2024/09/15
Bilog Antenna	R&S	HL562	CQA-011	2021/09/16	2024/09/15
Horn Antenna	R&S	HF906	CQA-012	2021/09/16	2024/09/15
Horn Antenna	Schwarzbeck	BBHA 9170	CQA-088	2021/09/16	2024/09/15
Coaxial Cable (Above 1GHz)	CQA	N/A	C007	2023/09/08	2024/09/07
Coaxial Cable (Below 1GHz)	CQA	N/A	C013	2023/09/08	2024/09/07
RF cable(9KHz~40GHz)	CQA	RF-01	CQA-079	2023/09/08	2024/09/07
Antenna Connector	CQA	RFC-01	CQA-080	2023/09/08	2024/09/07
Power Sensor	KEYSIGHT	U2021XA	CQA-30	2023/09/08	2024/09/07
N1918A Power Analysis Manager Power Panel	Agilent	N1918A	CQA-074	2023/09/08	2024/09/07
Power meter	R&S	NRVD	CQA-029	2023/09/08	2024/09/07
Power divider	MIDWEST	PWD-2533-02-SMA-79	CQA-067	2023/09/08	2024/09/07
EMI Test Receiver	R&S	ESR7	CQA-005	2023/09/08	2024/09/07
LISN	R&S	ENV216	CQA-003	2023/09/08	2024/09/07
Coaxial cable	CQA	N/A	CQA-C009	2023/09/08	2024/09/07
DC power	KEYSIGHT	E3631A	CQA-028	2023/09/08	2024/09/07

Test software:

	Manufacturer	Software brand
Radiated Emissions test software	Tonscend	JS1120-3
Conducted Emissions test software	Audix	e3
RF Conducted test software	Audix	e3

5 Test results and Measurement Data

5.1 Antenna Requirement

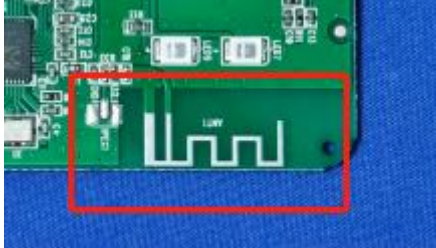
Standard requirement:	47 CFR Part 15C Section 15.203 /247(c)
<p>15.203 requirement: An intentional radiator shall be designed to ensure that no antenna other than that furnished by the responsible party shall be used with the device. The use of a permanently attached antenna or of an antenna that uses a unique coupling to the intentional radiator, the manufacturer may design the unit so that a broken antenna can be replaced by the user, but the use of a standard antenna jack or electrical connector is prohibited.</p> <p>15.247(b) (4) requirement: The conducted output power limit specified in paragraph (b) of this section is based on the use of antennas with directional gains that do not exceed 6 dBi. Except as shown in paragraph (c) of this section, if transmitting antennas of directional gain greater than 6 dBi are used, the conducted output power from the intentional radiator shall be reduced below the stated values in paragraphs (b)(1), (b)(2), and (b)(3) of this section, as appropriate, by the amount in dB that the directional gain of the antenna exceeds 6 dBi.</p>	
EUT Antenna:	
<p>The antenna is PCB antenna. The connection/connection type between the antenna to the EUT's antenna port is: permanently attachment. This is either permanently attachment or a unique coupling that satisfies the requirement.</p>	

5.2 Conducted Emissions

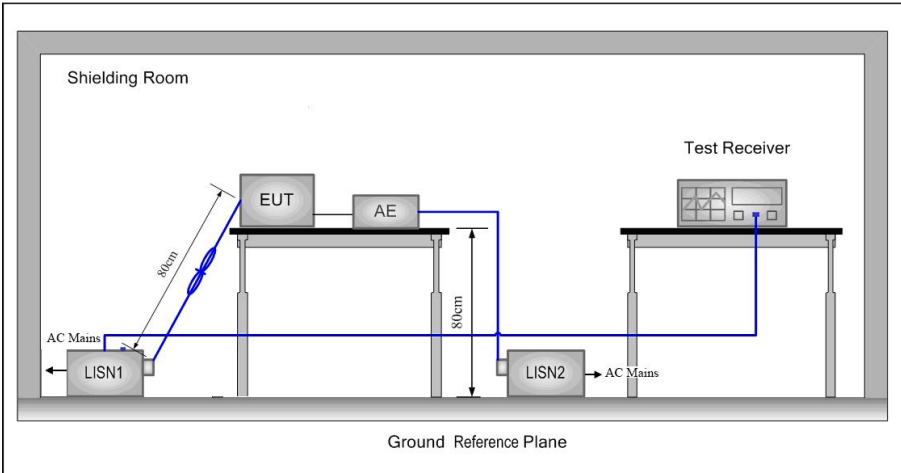
Test Requirement:	47 CFR Part 15C Section 15.207														
Test Method:	ANSI C63.10: 2013														
Test Frequency Range:	150kHz to 30MHz														
Limit:	<table border="1"> <thead> <tr> <th rowspan="2">Frequency range (MHz)</th> <th colspan="2">Limit (dBuV)</th> </tr> <tr> <th>Quasi-peak</th> <th>Average</th> </tr> </thead> <tbody> <tr> <td>0.15-0.5</td> <td>66 to 56*</td> <td>56 to 46*</td> </tr> <tr> <td>0.5-5</td> <td>56</td> <td>46</td> </tr> <tr> <td>5-30</td> <td>60</td> <td>50</td> </tr> </tbody> </table>	Frequency range (MHz)	Limit (dBuV)		Quasi-peak	Average	0.15-0.5	66 to 56*	56 to 46*	0.5-5	56	46	5-30	60	50
	Frequency range (MHz)		Limit (dBuV)												
		Quasi-peak	Average												
	0.15-0.5	66 to 56*	56 to 46*												
	0.5-5	56	46												
5-30	60	50													
* Decreases with the logarithm of the frequency.															
Test Procedure:	1) The mains terminal disturbance voltage test was conducted in a shielded room.														
	2) The EUT was connected to AC power source through a LISN 1 (Line Impedance Stabilization Network) which provides a $50\Omega/50\mu\text{H} + 5\Omega$ linear impedance. The power cables of all other units of the EUT were connected to a second LISN 2, which was bonded to the ground reference plane in the same way as the LISN 1 for the unit being measured. A multiple socket outlet strip was used to connect multiple power cables to a single LISN provided the rating of the LISN was not exceeded.														
	3) The tabletop EUT was placed upon a non-metallic table 0.8m above the ground reference plane. And for floor-standing arrangement, the EUT was placed on the horizontal ground reference plane,														
	4) The test was performed with a vertical ground reference plane. The rear of the EUT shall be 0.4 m from the vertical ground reference plane. The vertical ground reference plane was bonded to the horizontal ground reference plane. The LISN 1 was placed 0.8 m from the boundary of the unit under test and bonded to a ground reference plane for LISNs mounted on top of the ground reference plane. This distance was between the closest points of the LISN 1 and the EUT. All other units of the EUT and associated equipment was at least 0.8 m from the LISN 2.														
	5) In order to find the maximum emission, the relative positions of equipment and all of the interface cables must be changed according to ANSI C63.10: 2013 on conducted measurement.														
Test Setup:															

Exploratory Test Mode:	Transmitting with all kind of modulations, data rates at lowest, middle and highest channel.
Final Test Mode:	Through Pre-scan, find the 1Mbps of rate of 802.11b at middle channel is the worst case. Only the worst case is recorded in the report.
Test Voltage:	AC120V/60Hz
Test Results:	Pass

Measurement Data

Live Line:

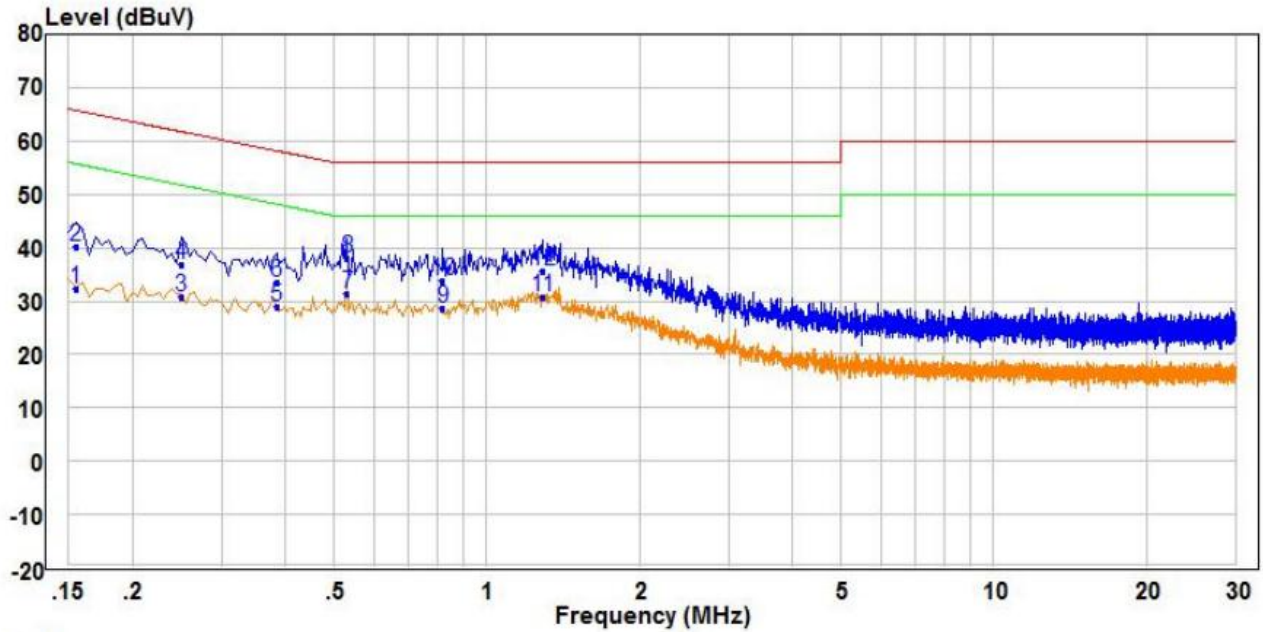

	Read Freq	Read Level	Factor	Limit Level	Limit Line	Over Limit	Remark	Pol/Phase
	MHz	dBuV	dB	dBuV	dBuV	dB		
1	0.155	22.70	9.69	32.39	55.73	-23.34	Average	Line
2	0.155	30.60	9.69	40.29	65.73	-25.44	QP	Line
3	0.250	21.29	9.55	30.84	51.76	-20.92	Average	Line
4	0.250	27.29	9.55	36.84	61.76	-24.92	QP	Line
5	0.385	19.36	9.59	28.95	48.17	-19.22	Average	Line
6	0.385	24.07	9.59	33.66	58.17	-24.51	QP	Line
7	PP 0.530	21.64	9.73	31.37	46.00	-14.63	Average	Line
8	QP 0.530	28.42	9.73	38.15	56.00	-17.85	QP	Line
9	0.820	18.91	9.82	28.73	46.00	-17.27	Average	Line
10	0.820	23.95	9.82	33.77	56.00	-22.23	QP	Line
11	1.290	20.24	10.41	30.65	46.00	-15.35	Average	Line
12	1.290	25.18	10.41	35.59	56.00	-20.41	QP	Line

Remark:

1. The following Quasi-Peak and Average measurements were performed on the EUT:
2. Final Test Level = Receiver Reading + LISN Factor + Cable Loss.
3. If the Peak value under Average limit, the Average value is not recorded in the report.

Neutral Line:

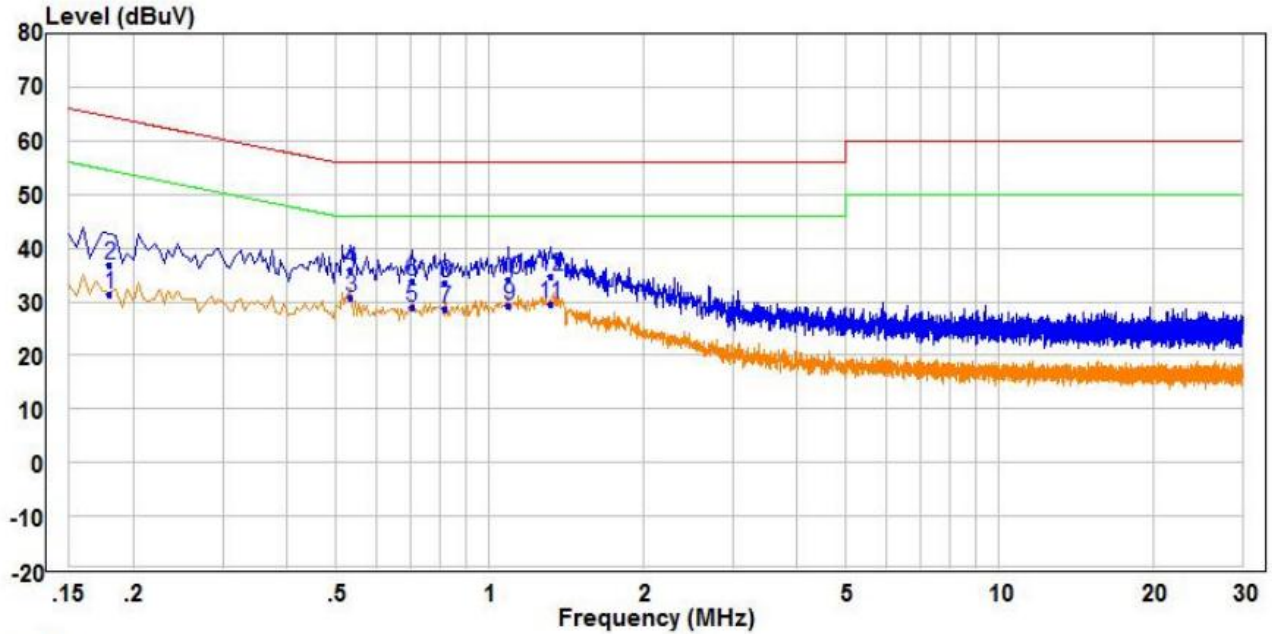

	Read			Limit	Over				
Freq	Level	Factor	Level	Line	Limit	Remark	Pol/Phase		
MHz	dBuV	dB	dBuV	dBuV	dB				
1	0.180	21.86	9.64	31.50	54.49	-22.99	Average	Neutral	
2	0.180	27.35	9.64	36.99	64.49	-27.50	QP	Neutral	
3	PP	0.535	21.12	9.74	30.86	46.00	-15.14	Average	Neutral
4	QP	0.535	26.20	9.74	35.94	56.00	-20.06	QP	Neutral
5	0.705	18.97	9.90	28.87	46.00	-17.13	Average	Neutral	
6	0.705	23.81	9.90	33.71	56.00	-22.29	QP	Neutral	
7	0.820	18.91	9.82	28.73	46.00	-17.27	Average	Neutral	
8	0.820	23.81	9.82	33.63	56.00	-22.37	QP	Neutral	
9	1.090	19.62	9.70	29.32	46.00	-16.68	Average	Neutral	
10	1.090	24.50	9.70	34.20	56.00	-21.80	QP	Neutral	
11	1.315	19.99	9.72	29.71	46.00	-16.29	Average	Neutral	
12	1.315	25.01	9.72	34.73	56.00	-21.27	QP	Neutral	

Remark:

1. The following Quasi-Peak and Average measurements were performed on the EUT:
2. Final Test Level =Receiver Reading + LISN Factor + Cable Loss.
3. If the Peak value under Average limit, the Average value is not recorded in the report.

5.3 Conducted Peak & Average Output Power

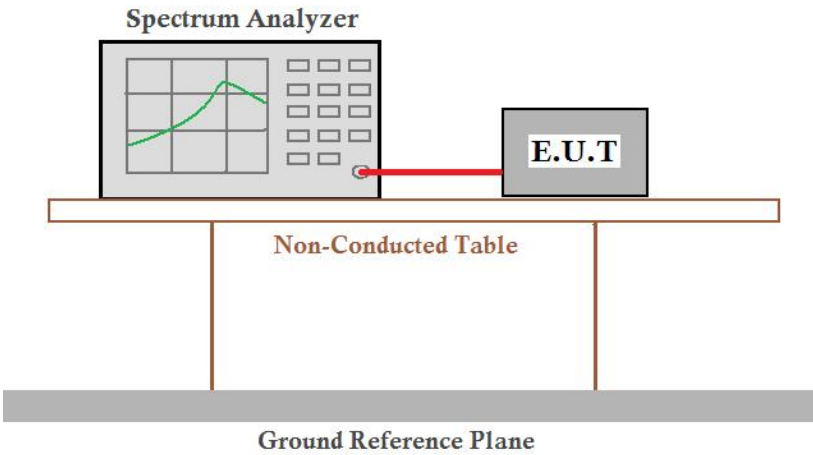
Test Requirement:	47 CFR Part 15C Section 15.247 (b)(3)
Test Method:	ANSI C63.10: 2013
Test Setup:	<p><i>Setup for Power meter measurement method</i></p>  <p><i>Setup for Spectrum analyser measurement method</i></p> 
Exploratory Test Mode:	Transmitting with all kind of modulations, data rates
Final Test Mode:	Only the worst case is recorded in the report.
Limit:	30dBm
Test Results:	Pass

Test Result

Test Mode	Frequency[MHz]	Result [dBm]	Limit [dBm]	Verdict
11B	2412	10.87	≤30.00	PASS
	2437	11.95	≤30.00	PASS
	2462	13.71	≤30.00	PASS
11G	2412	8.82	≤30.00	PASS
	2437	11.03	≤30.00	PASS
	2462	13.06	≤30.00	PASS
11N20SISO	2412	8.40	≤30.00	PASS
	2437	10.86	≤30.00	PASS
	2462	12.94	≤30.00	PASS

Note:

When Duty cycle >98%, D.C.F is not required.

Test Graphs

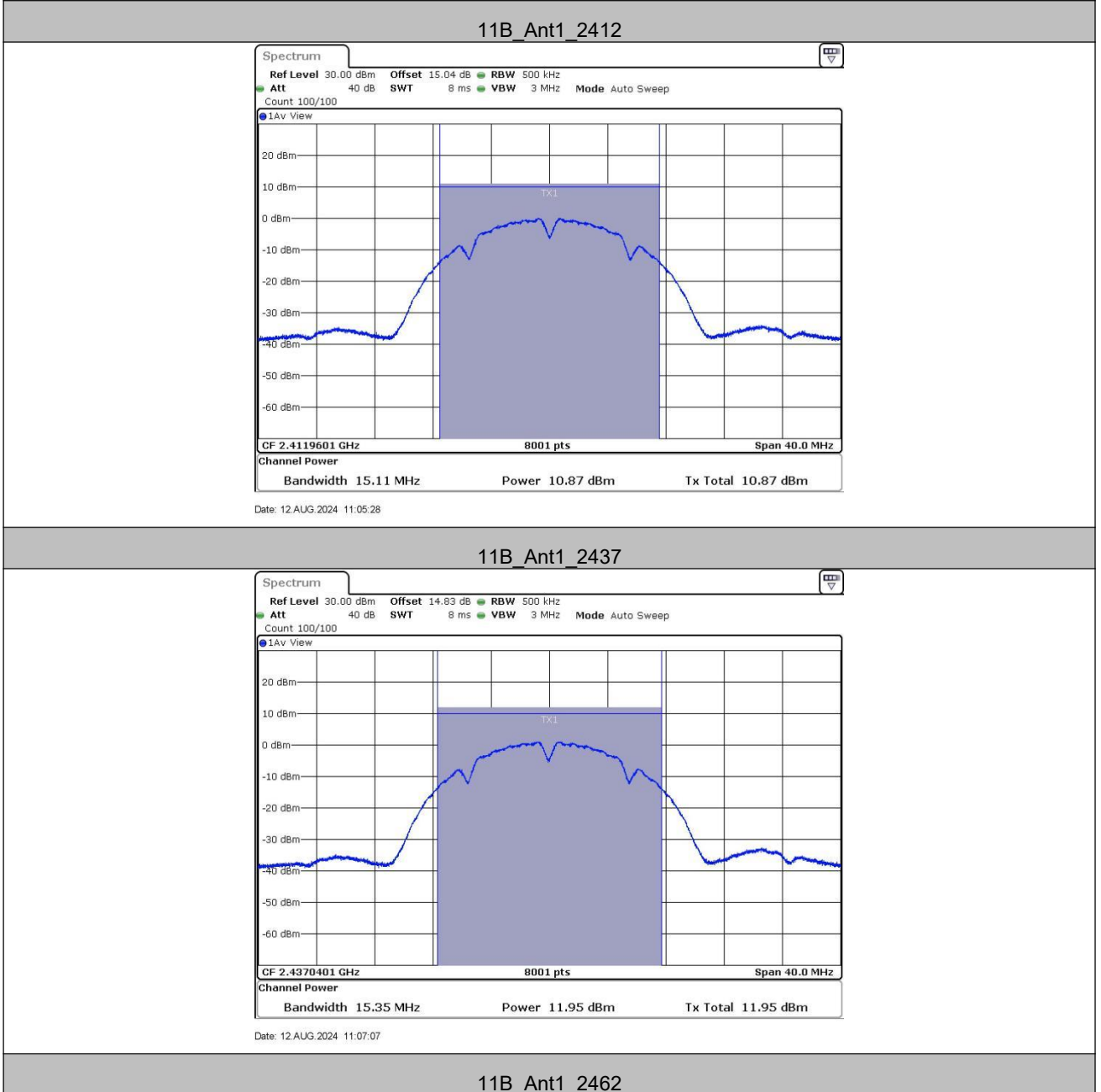

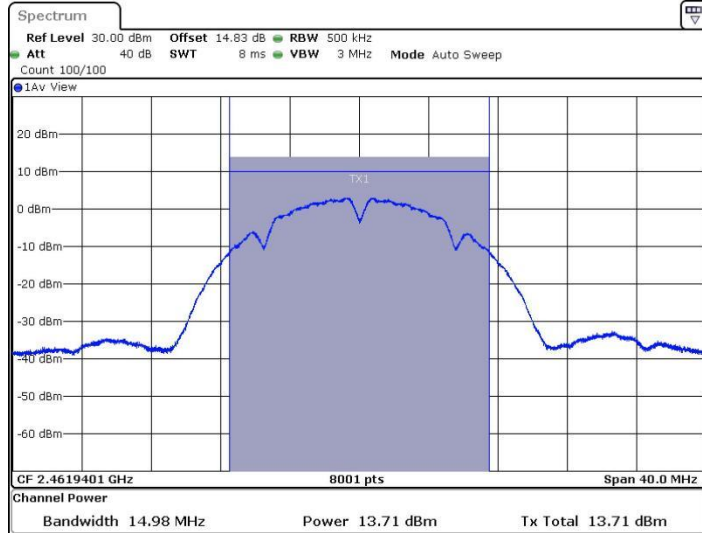

Date: 12 AUG.2024 11:08:50

11G_Ant1_2412

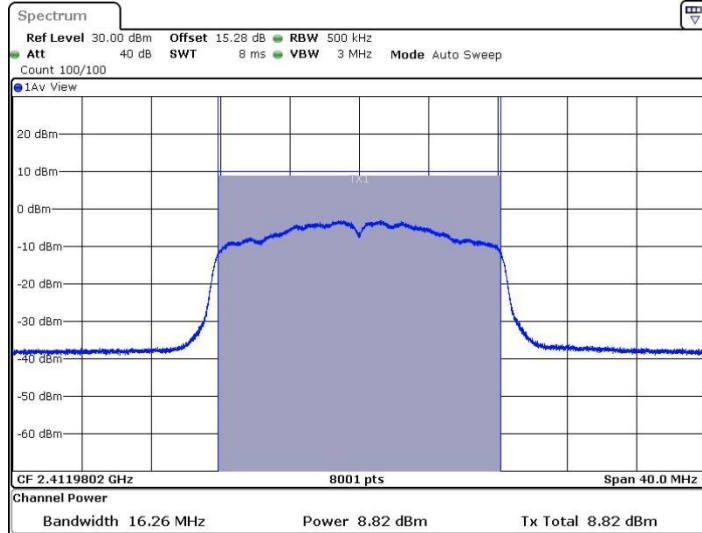

Date: 12 AUG.2024 10:50:53

11G_Ant1_2437

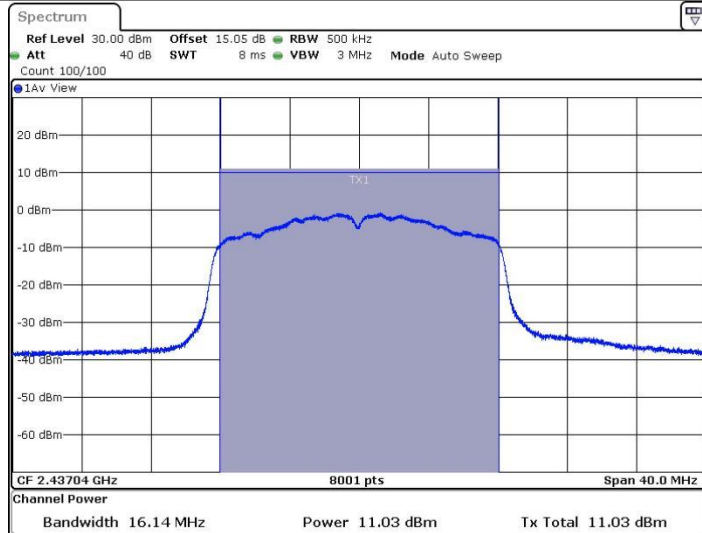

Date: 12 AUG.2024 10:52:53

11G_Ant1_2462

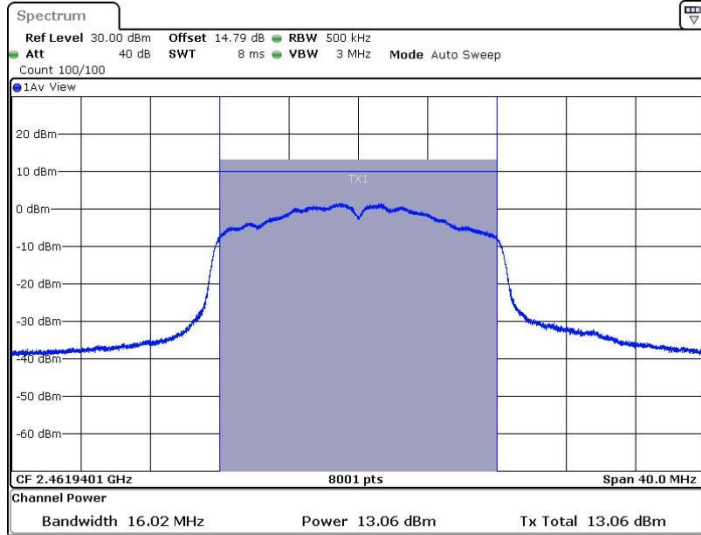

Date: 12 AUG.2024 10:54:26

11N20SISO_Ant1_2412

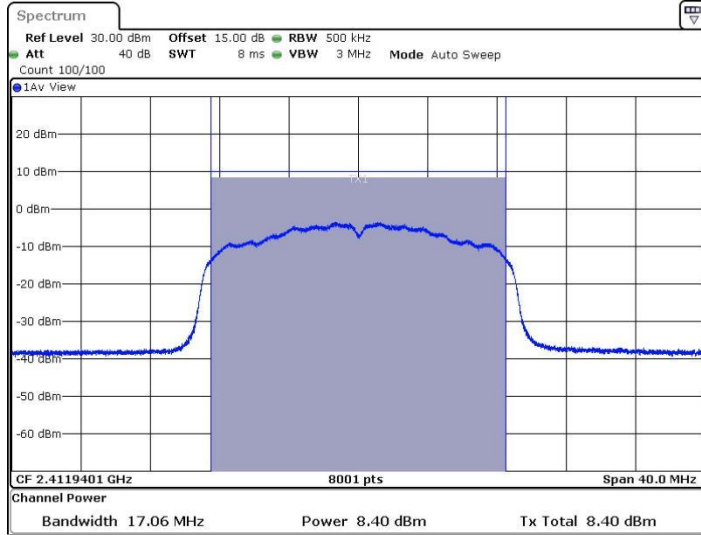

Date: 12 AUG.2024 10:56:29

11N20SISO_Ant1_2437

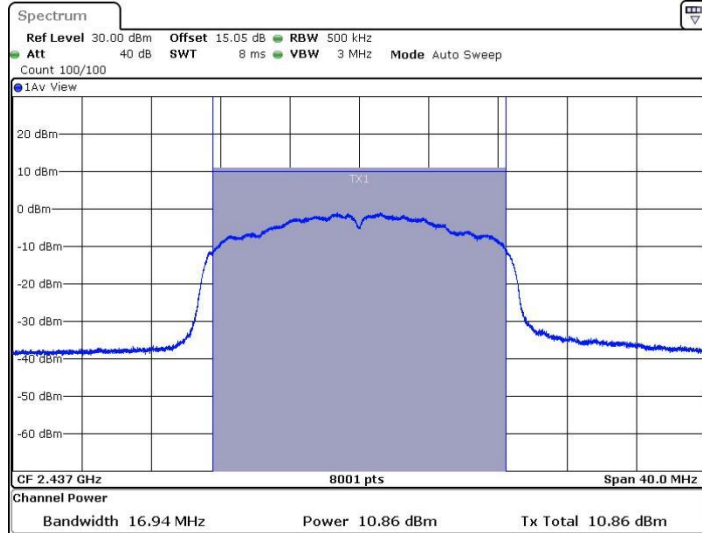

Date: 12.AUG.2024 10:58:24

11N20SISO_Ant1_2462

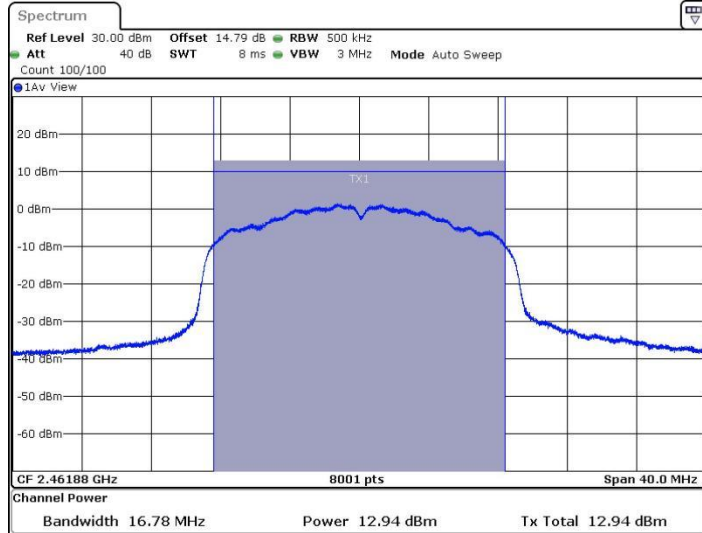

Date: 12.AUG.2024 11:03:24

5.4 6dB Occupied Bandwidth

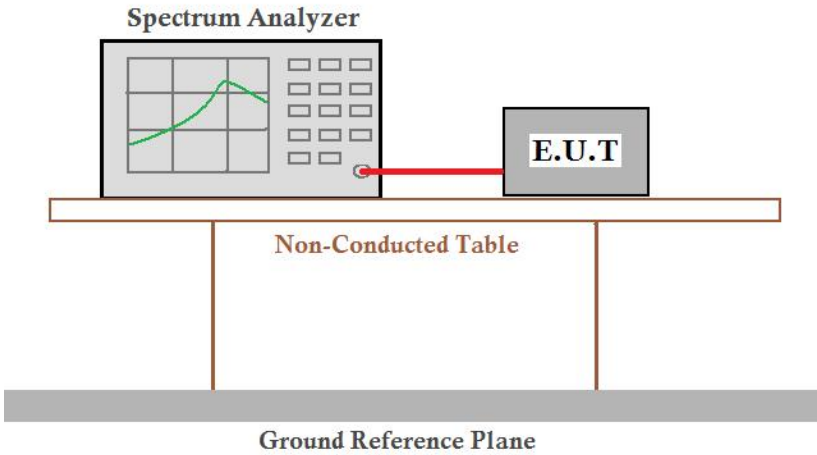
Test Requirement:	47 CFR Part 15C Section 15.247 (a)(2)
Test Method:	ANSI C63.10: 2013
Test Setup:	 <p style="text-align: center;">Offset=cable loss+ attenuation factor</p>
Exploratory Test Mode:	Transmitting with all kind of modulations, data rates
Final Test Mode:	Only the worst case is recorded in the report.
Limit:	≥ 500 kHz
Test Results:	Pass

Test Result

TestMode	Frequency[MHz]	DTS BW [MHz]	FL[MHz]	FH[MHz]	Limit[MHz]	Verdict
11B	2412	10.08	2406.92	2417.00	0.5	PASS
	2437	9.56	2432.40	2441.96	0.5	PASS
	2462	10.00	2456.96	2466.96	0.5	PASS
11G	2412	15.04	2404.44	2419.48	0.5	PASS
	2437	13.80	2430.68	2444.48	0.5	PASS
	2462	11.32	2455.68	2467.00	0.5	PASS
11N20SISO	2412	15.04	2404.44	2419.48	0.5	PASS
	2437	15.00	2429.48	2444.48	0.5	PASS
	2462	11.32	2455.68	2467.00	0.5	PASS

Test Graphs

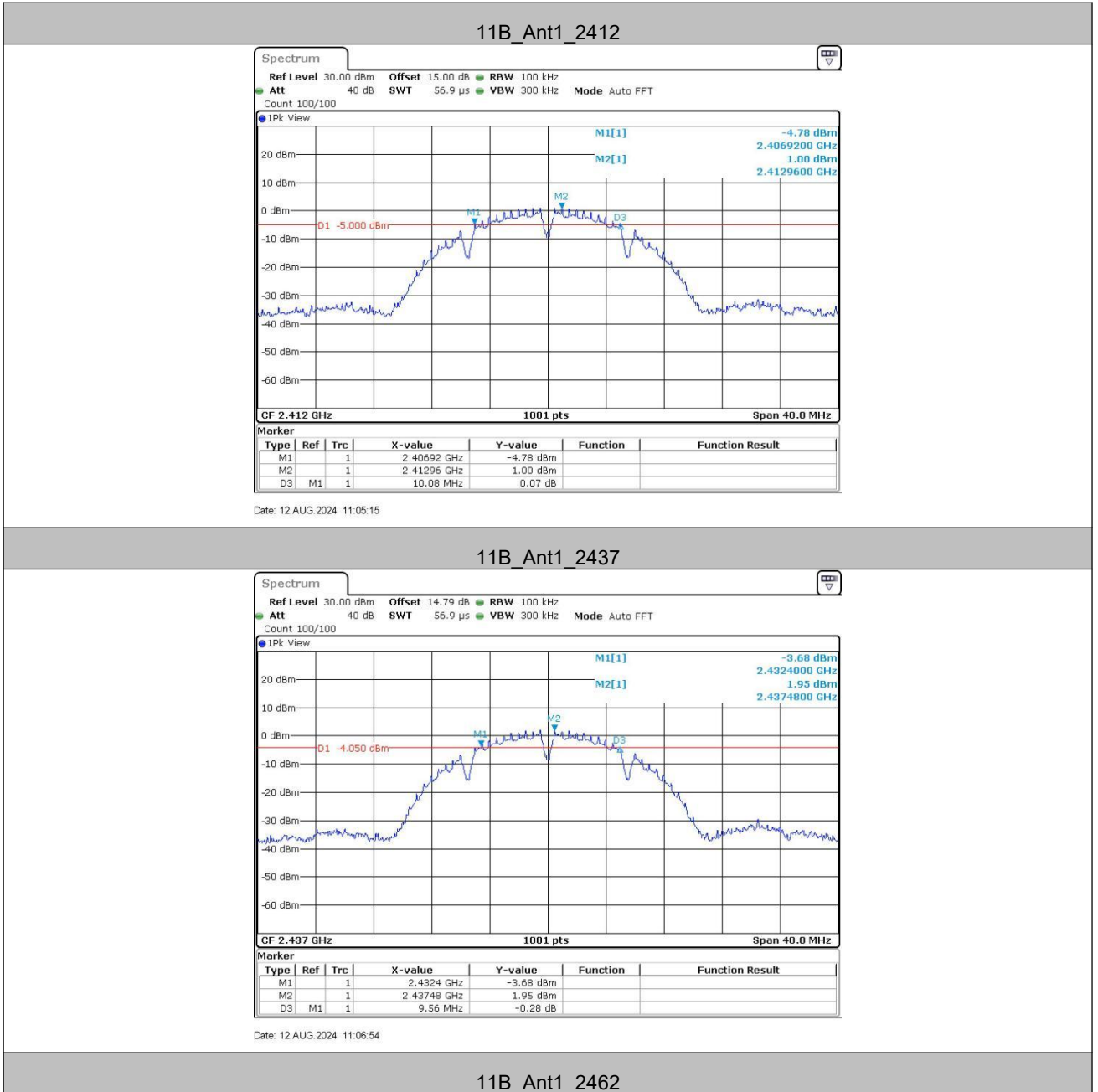

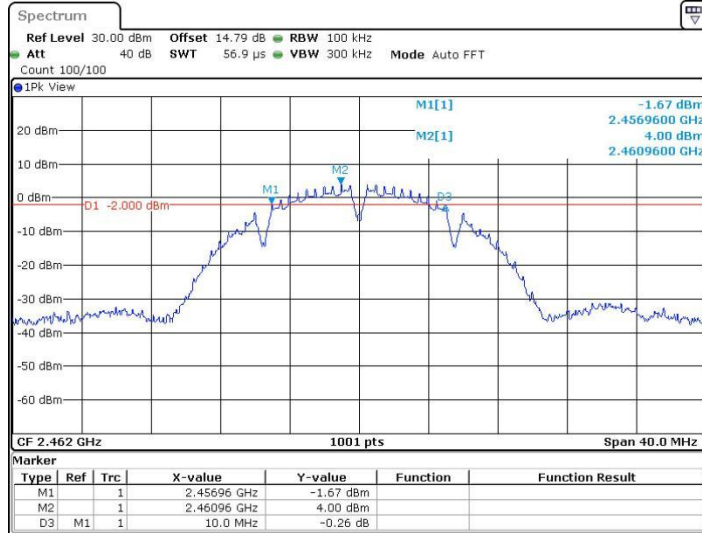

Date: 12.AUG.2024 11:08:37

11G_Ant1_2412

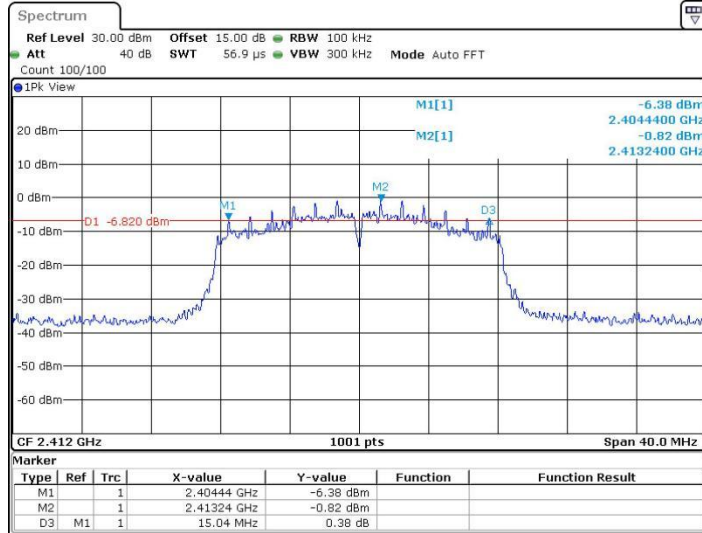

Date: 12.AUG.2024 10:50:40

11G_Ant1_2437

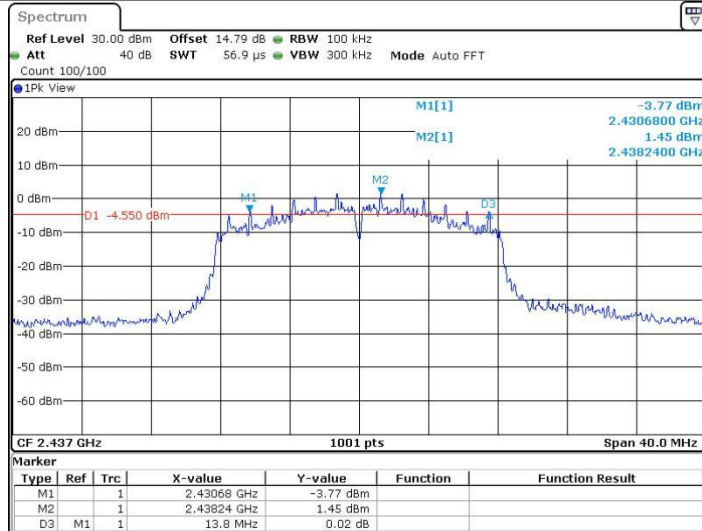

Date: 12.AUG.2024 10:52:40

11G_Ant1_2462

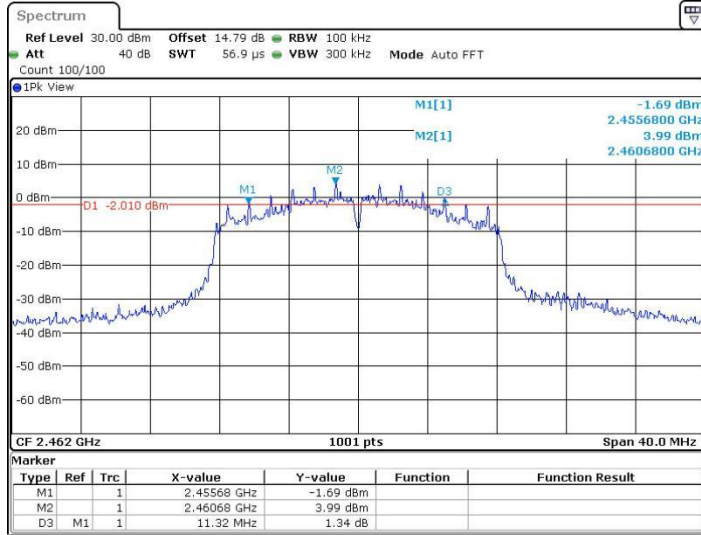

Date: 12 AUG 2024 10:54:13

11N20SISO_Ant1_2412

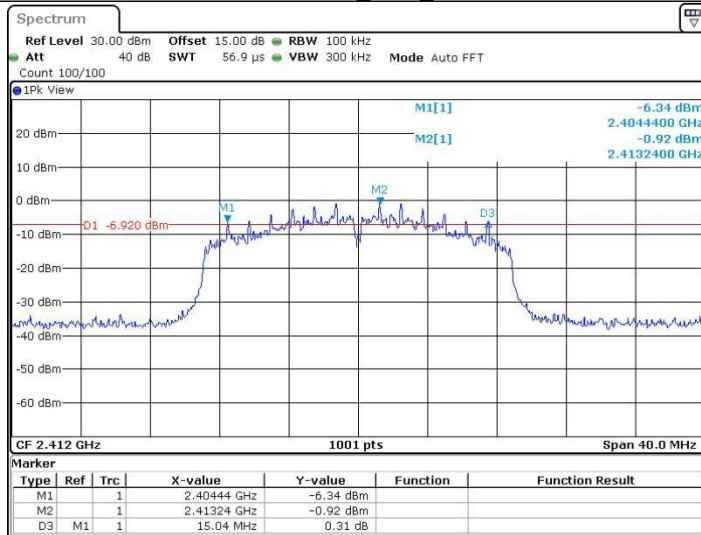

Date: 12 AUG 2024 10:56:16

11N20SISO_Ant1_2437

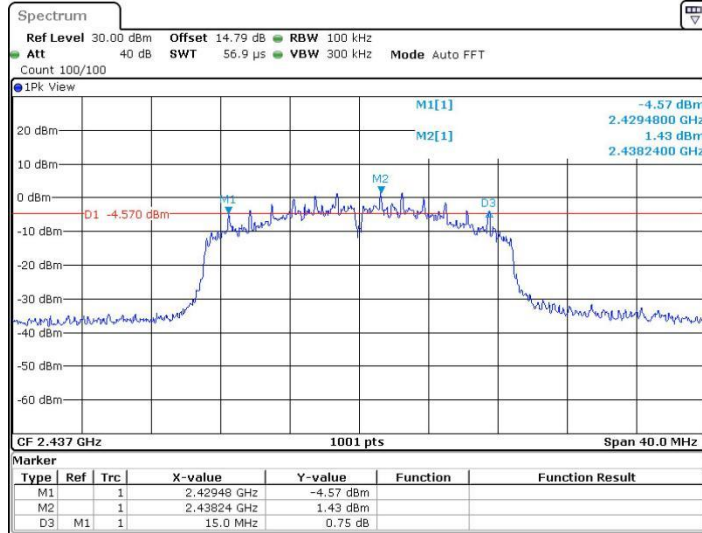

Date: 12 AUG.2024 10:58:11

11N20SISO_Ant1_2462

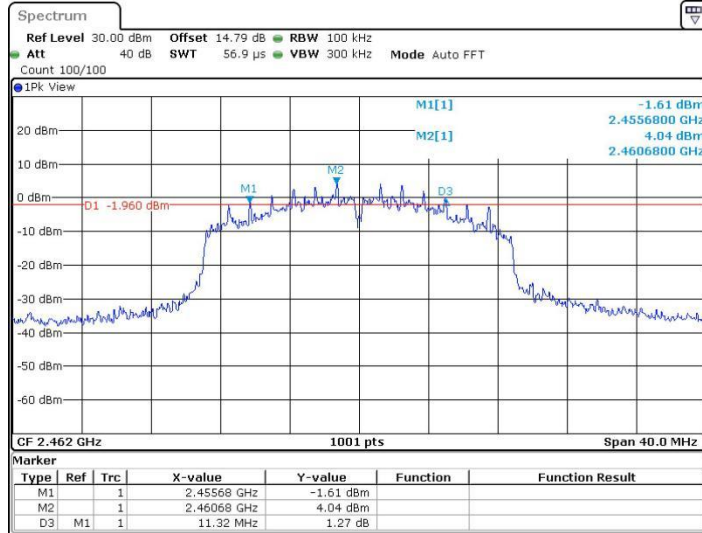

Date: 12 AUG.2024 11:03:11

5.5 Power Spectral Density

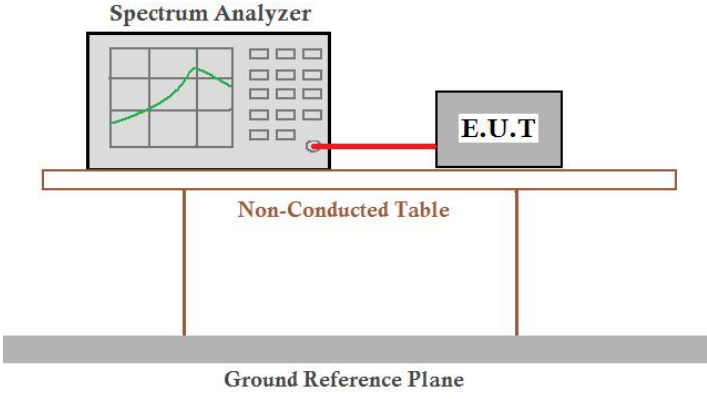
Test Requirement:	47 CFR Part 15C Section 15.247 (e)
Test Method:	ANSI C63.10: 2013
Test Setup:	 <p>Offset=cable loss+ attenuation factor</p>
Exploratory Test Mode:	Transmitting with all kind of modulations, data rates
Final Test Mode:	Only the worst case is recorded in the report.
Limit:	≤8.00dBm/3kHz
Test Results:	Pass

Test Result

TestMode	Frequency[MHz]	Result[dBm/3-100kHz]	Limit[dBm/3kHz]	Verdict
11B	2412	-16.94	≤8.00	PASS
	2437	-16.06	≤8.00	PASS
	2462	-13.7	≤8.00	PASS
11G	2412	-17.16	≤8.00	PASS
	2437	-14.44	≤8.00	PASS
	2462	-11.87	≤8.00	PASS
11N20SISO	2412	-18.08	≤8.00	PASS
	2437	-15.3	≤8.00	PASS
	2462	-13.26	≤8.00	PASS

Note:

When Duty cycle >98%, D.C.F is not required.

Test Graphs

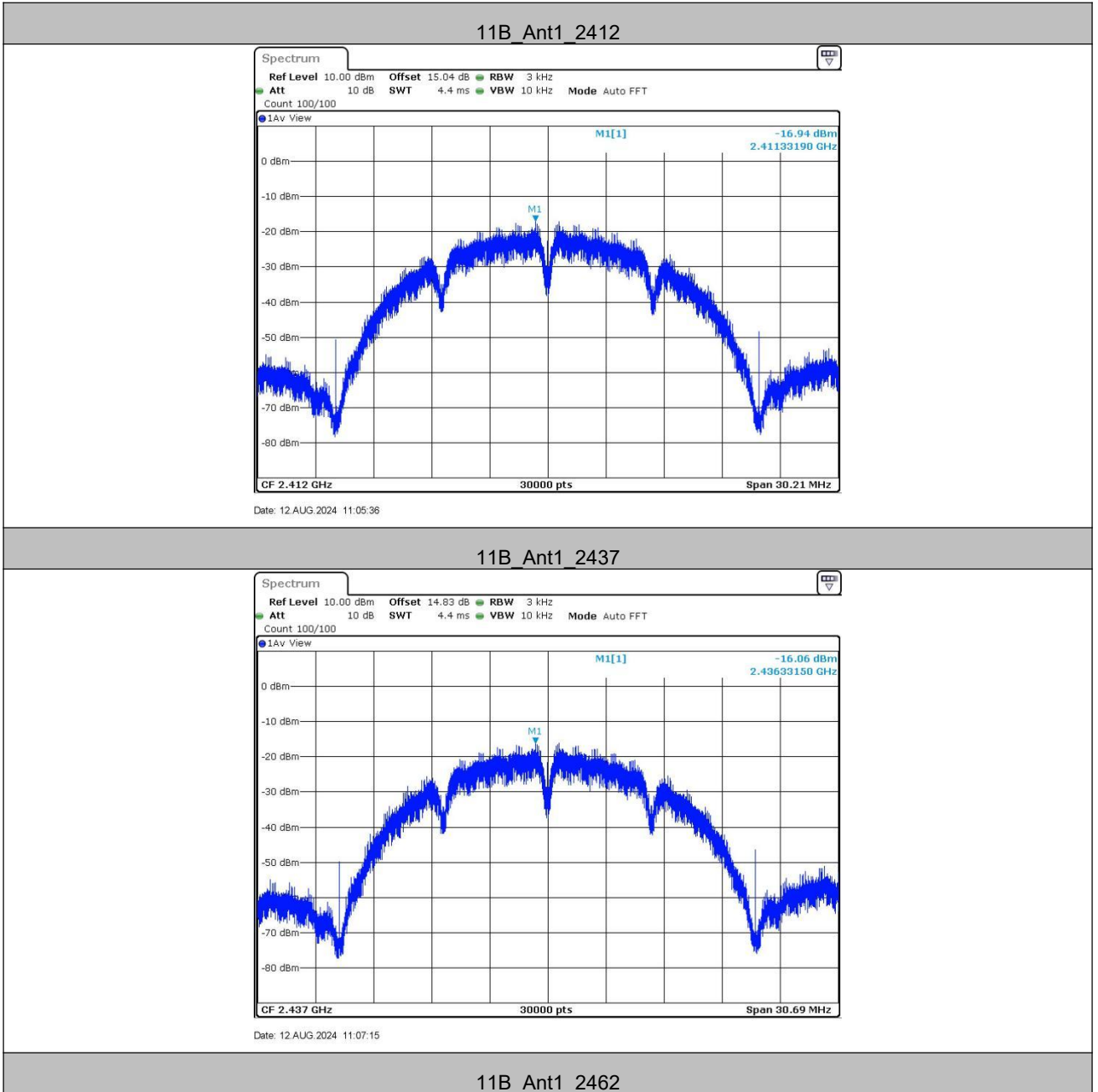

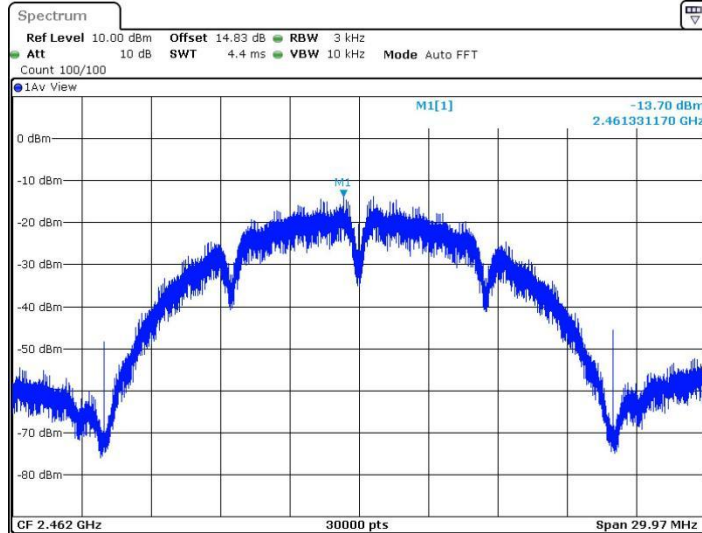

Date: 12.AUG.2024 11:08:58

11G_Ant1_2412

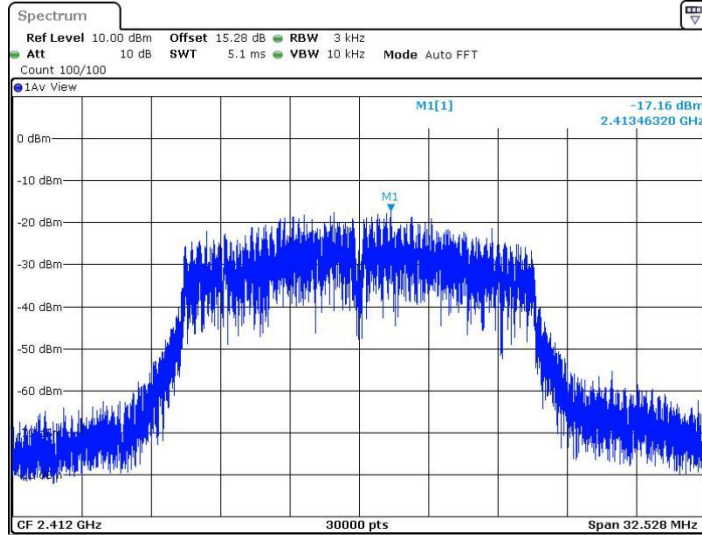

Date: 12.AUG.2024 10:51:01

11G_Ant1_2437

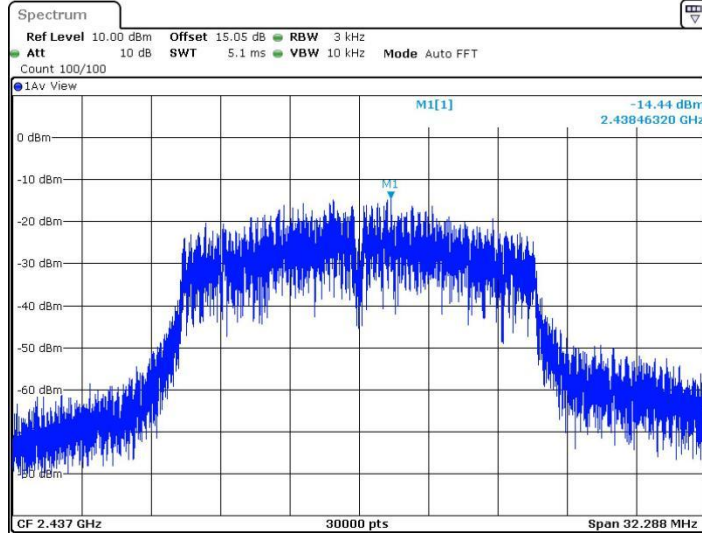

Date: 12.AUG.2024 10:53:01

11G_Ant1_2462

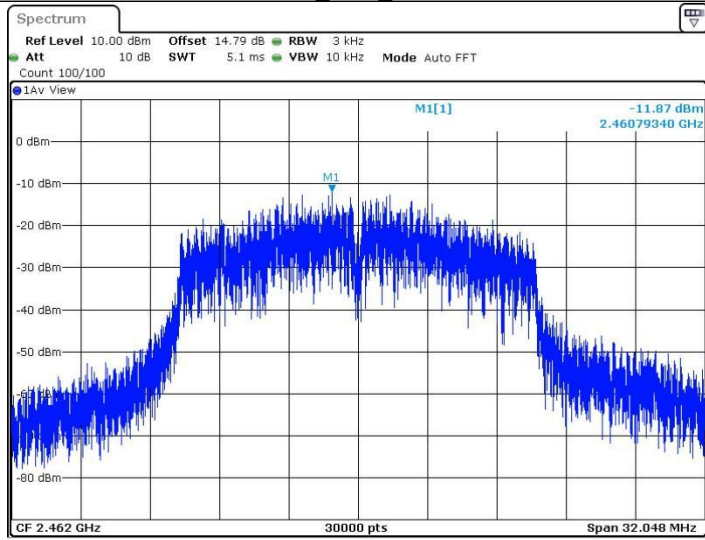

Date: 12 AUG 2024 10:54:34

11N20SISO_Ant1_2412

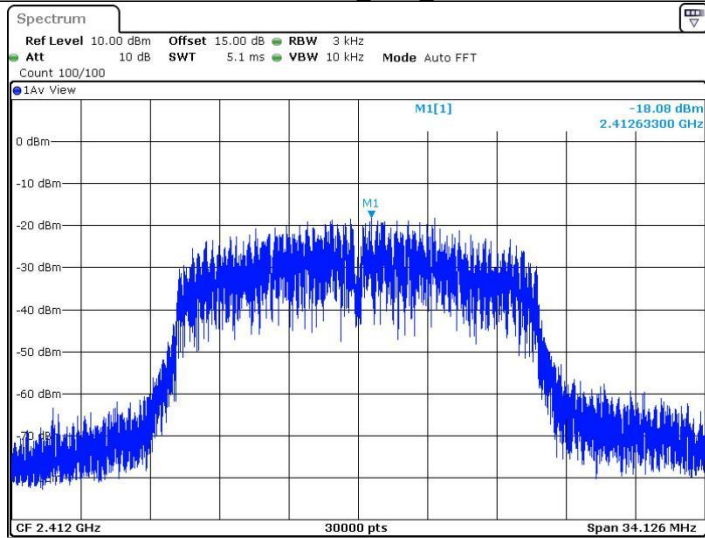

Date: 12 AUG 2024 10:56:37

11N20SISO_Ant1_2437

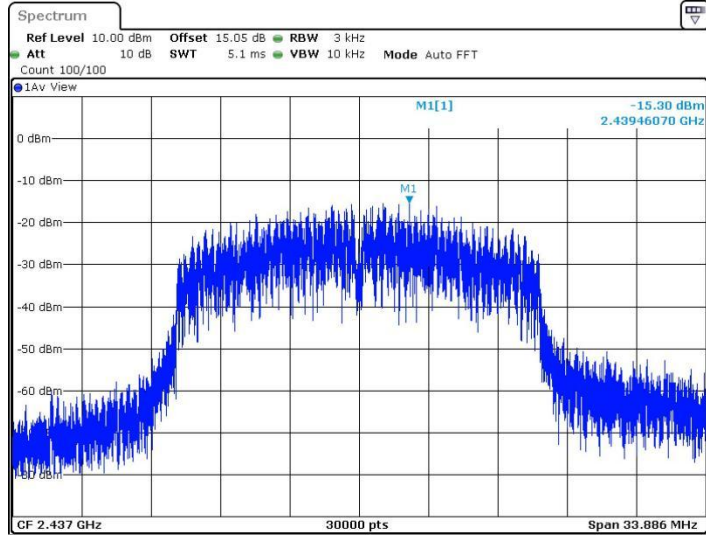

Date: 12.AUG.2024 10:58:32

11N20SISO_Ant1_2462

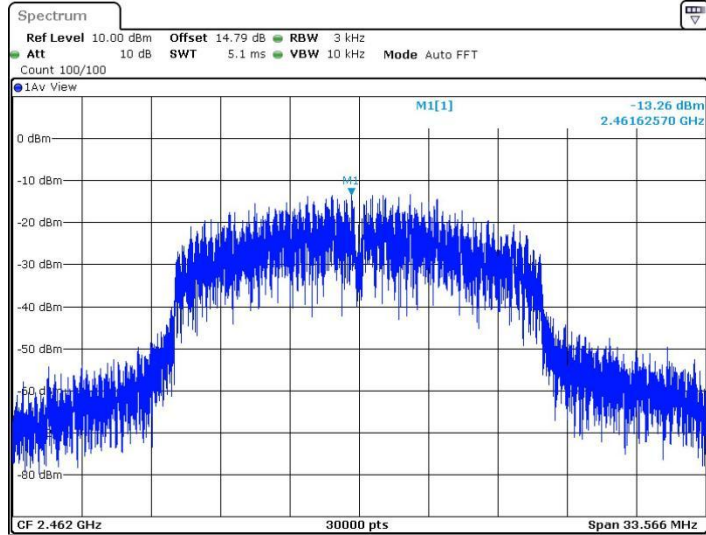

Date: 12.AUG.2024 11:03:32

5.6 Band-edge for RF Conducted Emissions

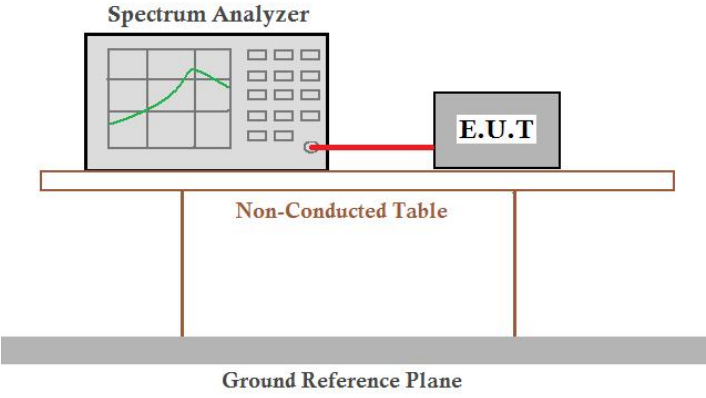
Test Requirement:	47 CFR Part 15C Section 15.247 (d)
Test Method:	ANSI C63.10: 2013
Test Setup:	 <p>Offset=cable loss+ attenuation factor</p>
Exploratory Test Mode:	Transmitting with all kind of modulations, data rates
Final Test Mode:	Only the worst case is recorded in the report.
Limit:	In any 100 kHz bandwidth outside the frequency band in which the spread spectrum intentional radiator is operating, the radio frequency power that is produced by the intentional radiator shall be at least 30 dB below that in the 100 kHz bandwidth within the band that contains the highest level of the desired power, based on either an RF conducted or a radiated measurement.
Test Results:	Pass

Test Result

TestMode	ChName	Frequency[MHz]	RefLevel[dBm]	Result[dBm]	Limit[dBm]	Verdict
11B	Low	2412	0.99	-37.07	≤-29.01	PASS
	High	2462	3.93	-42.77	≤-26.07	PASS
11G	Low	2412	-0.78	-42.49	≤-30.78	PASS
	High	2462	4.05	-42.97	≤-25.95	PASS
11N20SISO	Low	2412	-0.78	-42.4	≤-30.78	PASS
	High	2462	4.08	-43.01	≤-25.92	PASS

5.6.1 Test Graphs

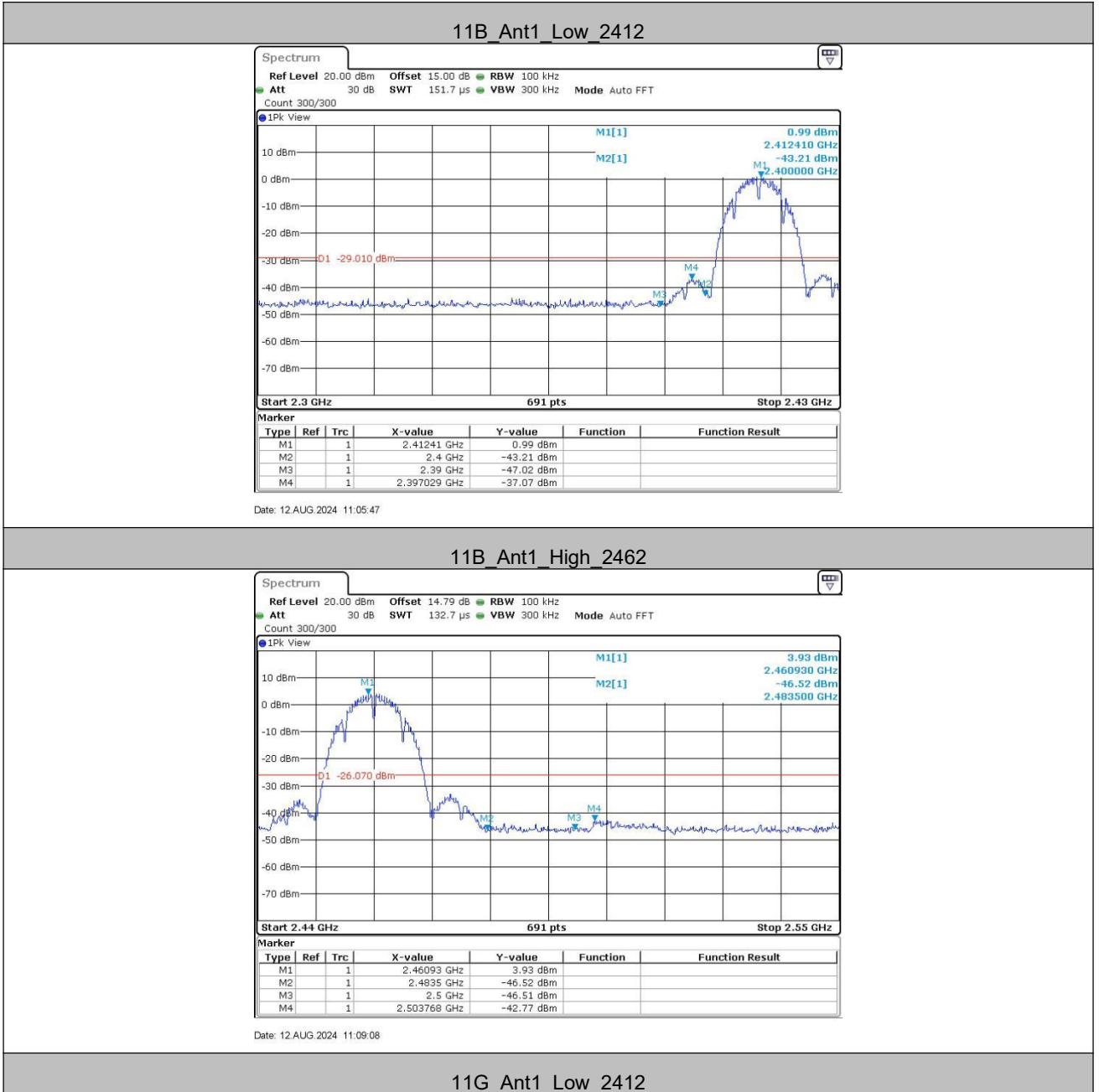

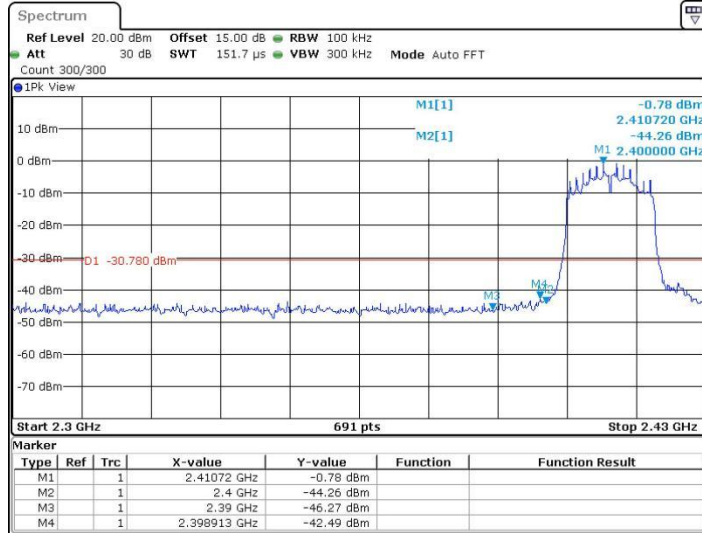

Date: 12.AUG.2024 10:51:11

11G_Ant1_High_2462

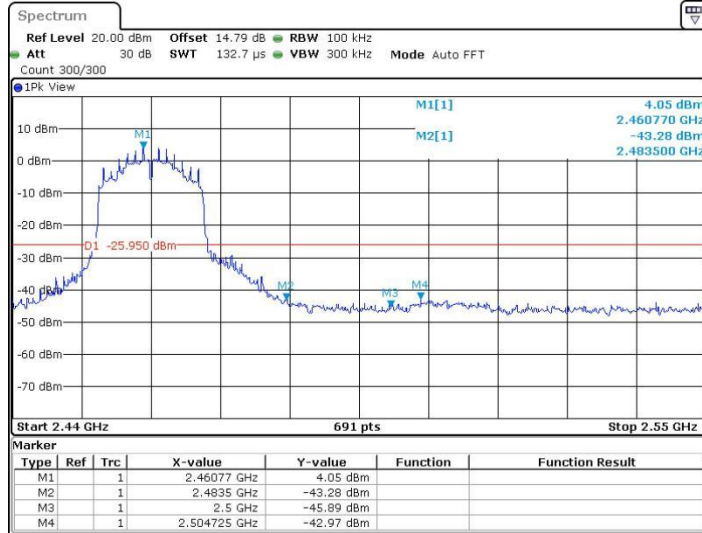

Date: 12.AUG.2024 10:54:44

11N20SISO_Ant1_Low_2412

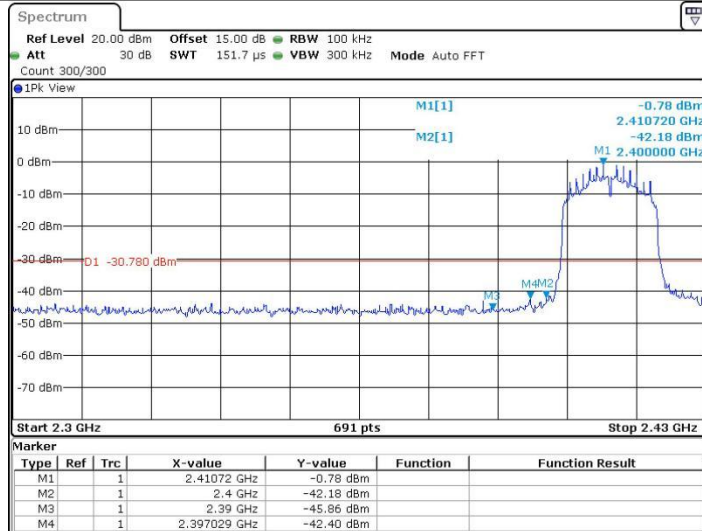

Date: 12.AUG.2024 10:56:47

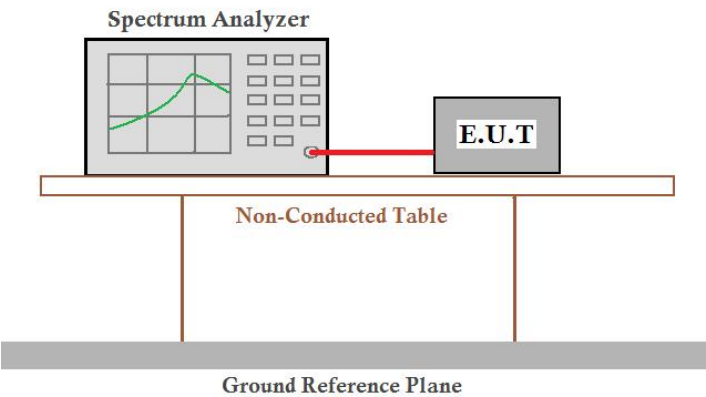

5.7 RF Conducted Spurious Emissions

Test Requirement:	47 CFR Part 15C Section 15.247 (d)
Test Method:	ANSI C63.10: 2013
Test Setup:	 <p>The diagram illustrates the test setup for RF conducted spurious emissions. A Spectrum Analyzer is connected via a red cable to an E.U.T. (Equipment Under Test). Both are placed on a Non-Conducted Table, which is supported by two vertical legs. Below the table is a Ground Reference Plane, represented by a thick grey bar.</p> <p>Offset=cable loss+ attenuation factor</p>
Exploratory Test Mode:	Transmitting with all kind of modulations, data rates
Final Test Mode:	Only the worst case is recorded in the report.
Limit:	In any 100 kHz bandwidth outside the frequency band in which the spread spectrum intentional radiator is operating, the radio frequency power that is produced by the intentional radiator shall be at least 30 dB below that in the 100 kHz bandwidth within the band that contains the highest level of the desired power, based on either an RF conducted or a radiated measurement.
Test Results:	Pass

Test Result

TestMode	Frequency[MHz]	FreqRange [Mhz]	RefLevel [dBm]	Result [dBm]	Limit [dBm]	Verdict
11B	2412	Reference	1.27	1.27	---	PASS
		30~1000	1.27	-51.94	≤-28.73	PASS
		1000~26500	1.27	-48.18	≤-28.73	PASS
	2437	Reference	2.42	2.42	---	PASS
		30~1000	2.42	-51.37	≤-27.58	PASS
		1000~26500	2.42	-48.06	≤-27.58	PASS
	2462	Reference	3.84	3.84	---	PASS
		30~1000	3.84	-52.59	≤-26.16	PASS
		1000~26500	3.84	-47.18	≤-26.16	PASS
11G	2412	Reference	-0.77	-0.77	---	PASS
		30~1000	-0.77	-51.8	≤-30.77	PASS
		1000~26500	-0.77	-48.4	≤-30.77	PASS
	2437	Reference	1.59	1.59	---	PASS
		30~1000	1.59	-51.6	≤-28.41	PASS
		1000~26500	1.59	-48.71	≤-28.41	PASS
	2462	Reference	3.85	3.85	---	PASS
		30~1000	3.85	-52.03	≤-26.15	PASS
		1000~26500	3.85	-48.61	≤-26.15	PASS
11N20SISO	2412	Reference	-0.76	-0.76	---	PASS
		30~1000	-0.76	-51.5	≤-30.76	PASS
		1000~26500	-0.76	-47.97	≤-30.76	PASS
	2437	Reference	1.55	1.55	---	PASS
		30~1000	1.55	-52.22	≤-28.45	PASS
		1000~26500	1.55	-48.54	≤-28.45	PASS
	2462	Reference	3.89	3.89	---	PASS
		30~1000	3.89	-51.98	≤-26.11	PASS
		1000~26500	3.89	-48.83	≤-26.11	PASS

Test Graphs

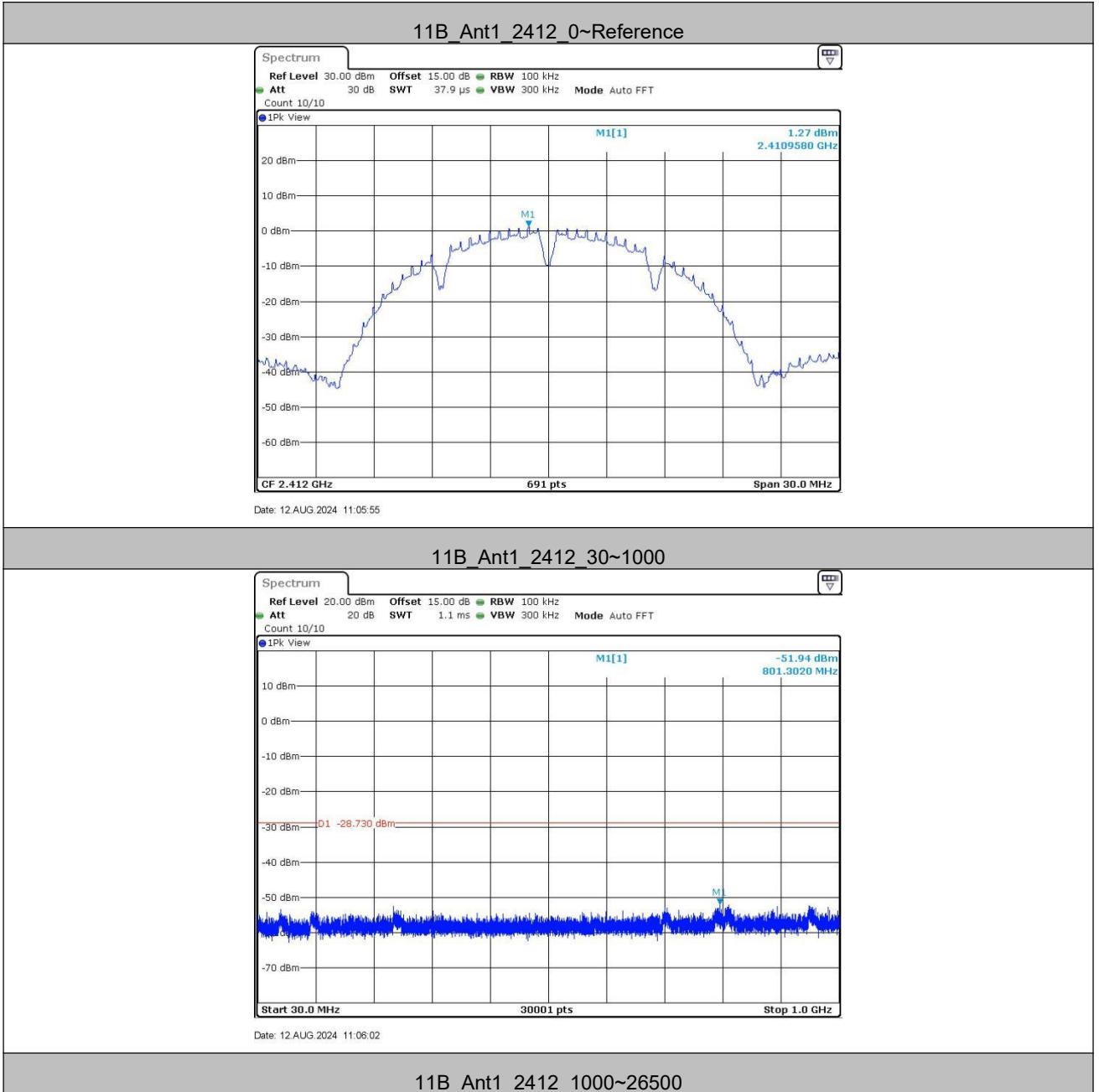

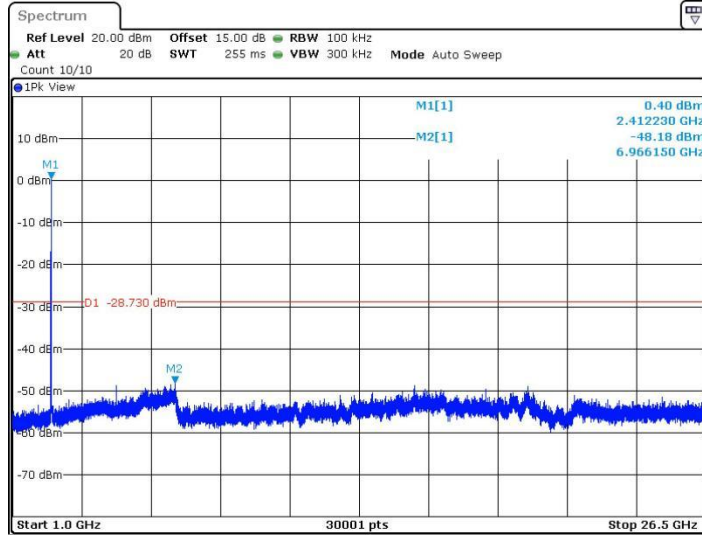

Date: 12.AUG.2024 11:06:24

11B_Ant1_2437_0~Reference

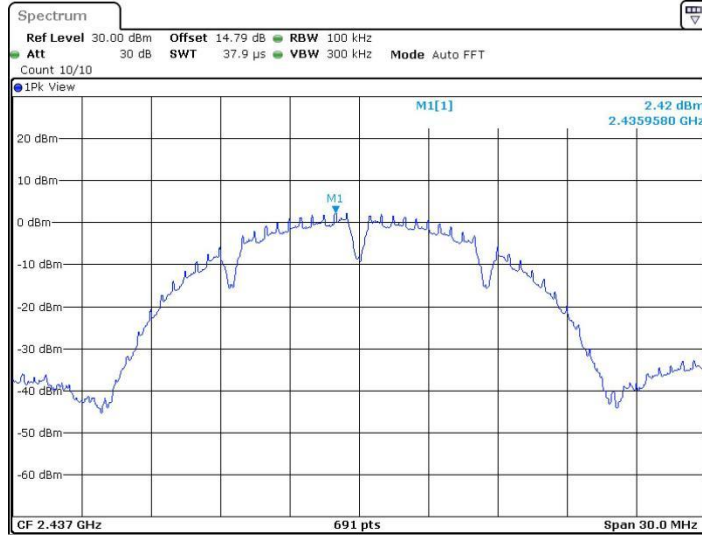

Date: 12.AUG.2024 11:07:24

11B_Ant1_2437_30~1000

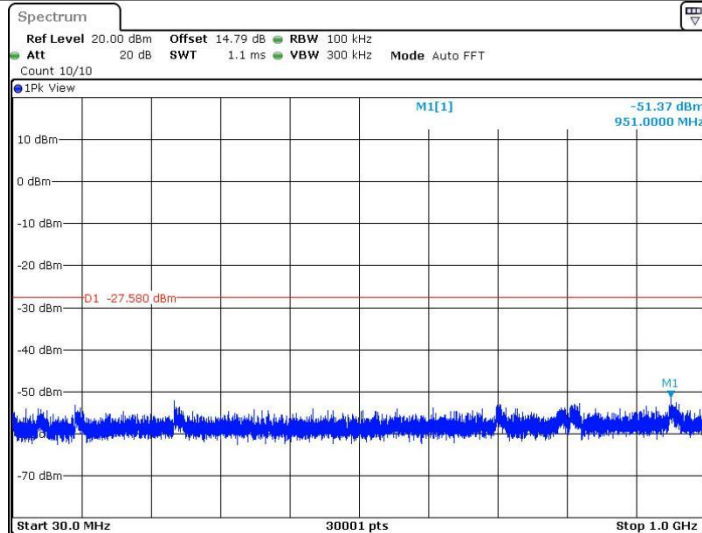

Date: 12.AUG.2024 11:07:30

11B_Ant1_2437_1000~26500

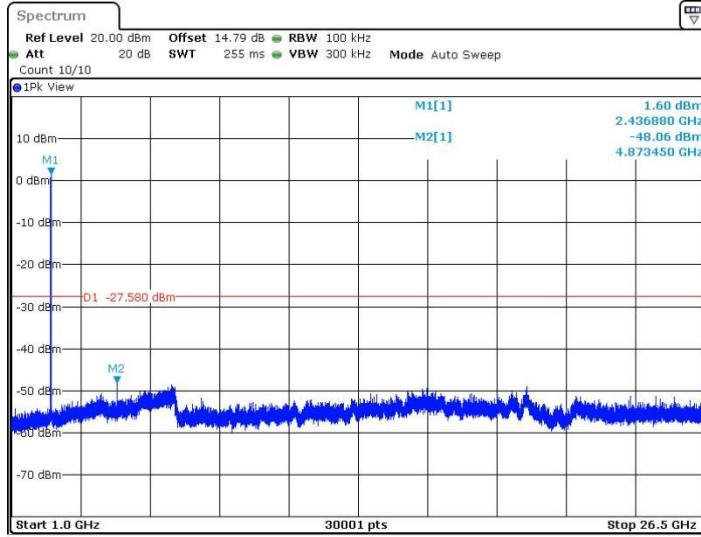

Date: 12 AUG 2024 11:07:52

11B_Ant1_2462_0~Reference

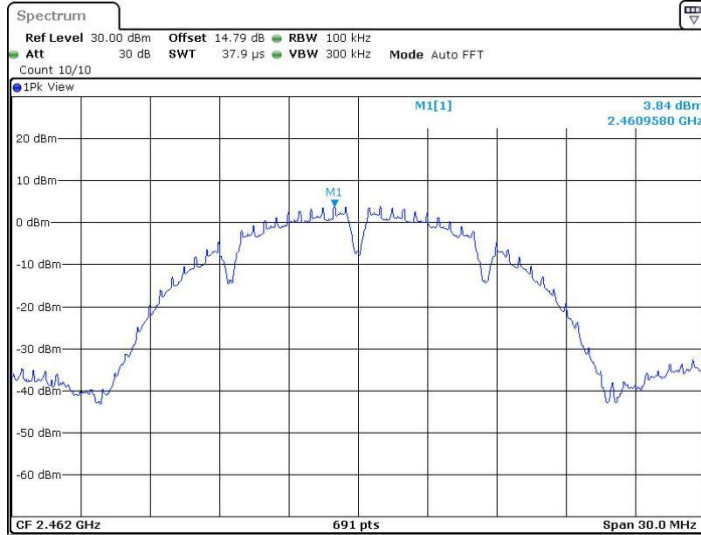

Date: 12 AUG 2024 11:09:17

11B_Ant1_2462_30~1000

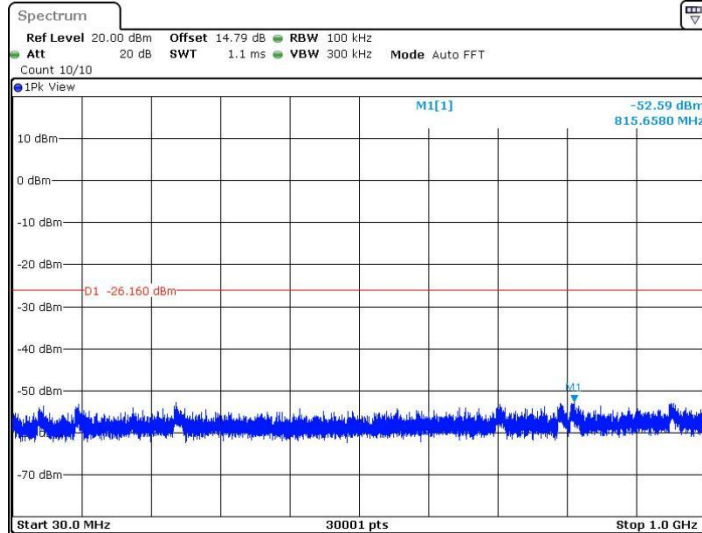

Date: 12 AUG.2024 11:09:23

11B_Ant1_2462_1000~26500

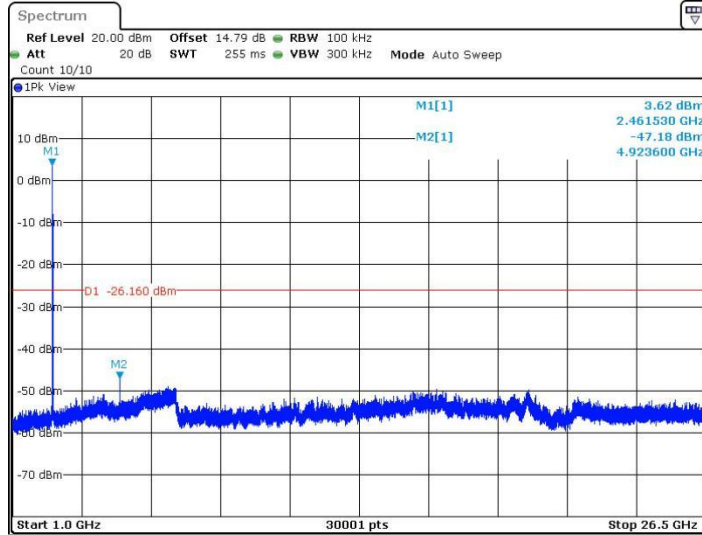

Date: 12 AUG.2024 11:09:45

11G_Ant1_2412_0~Reference

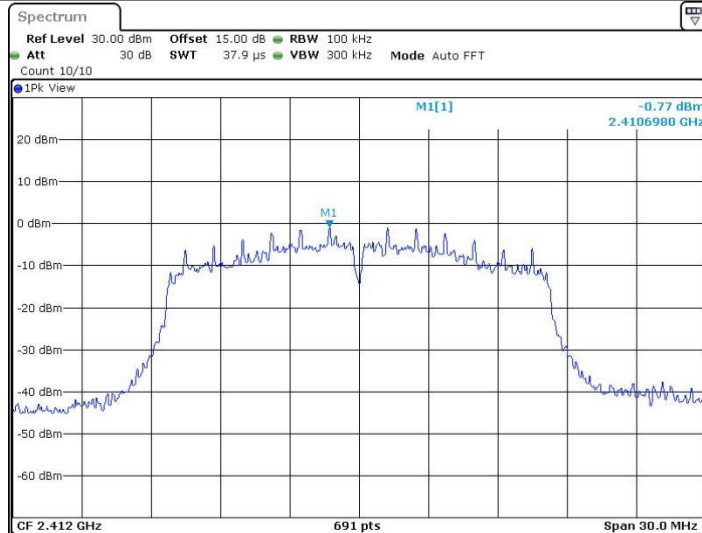

Date: 12 AUG.2024 10:51:20

11G Ant1_2412_30~1000

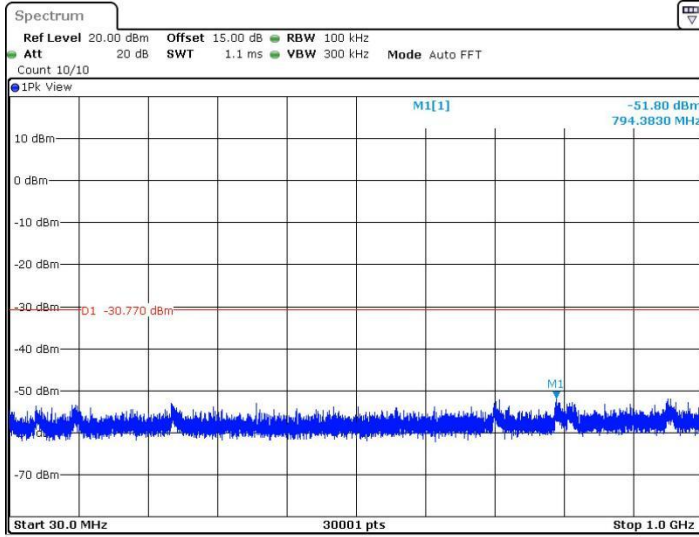

Date: 12 AUG 2024 10:51:27

11G Ant1_2412_1000~26500

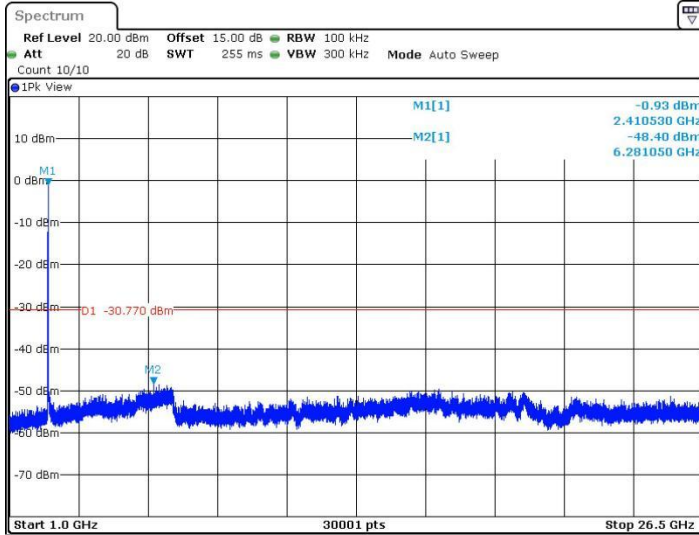

Date: 12 AUG 2024 10:51:49

11G Ant1_2437_0~Reference

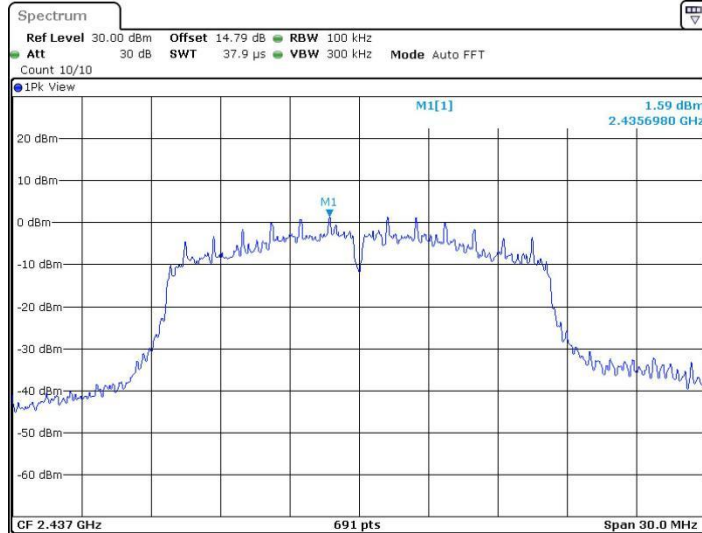

Date: 12.AUG.2024 10:53:10

11G_Ant1_2437_30~1000

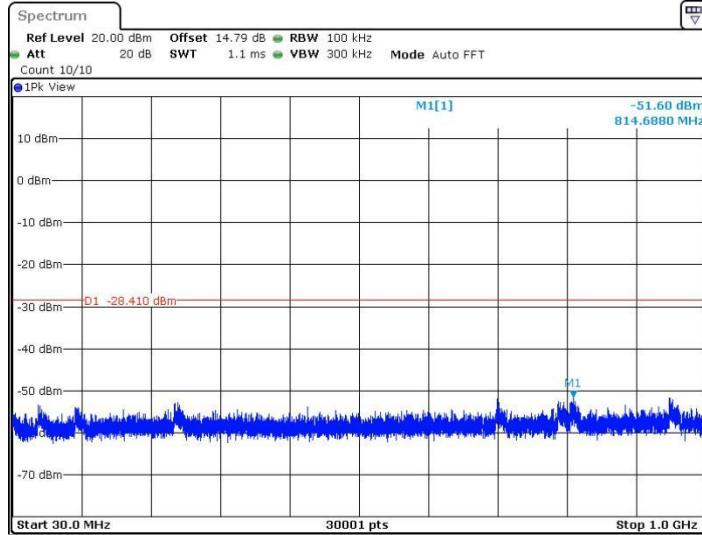

Date: 12.AUG.2024 10:53:16

11G_Ant1_2437_1000~26500

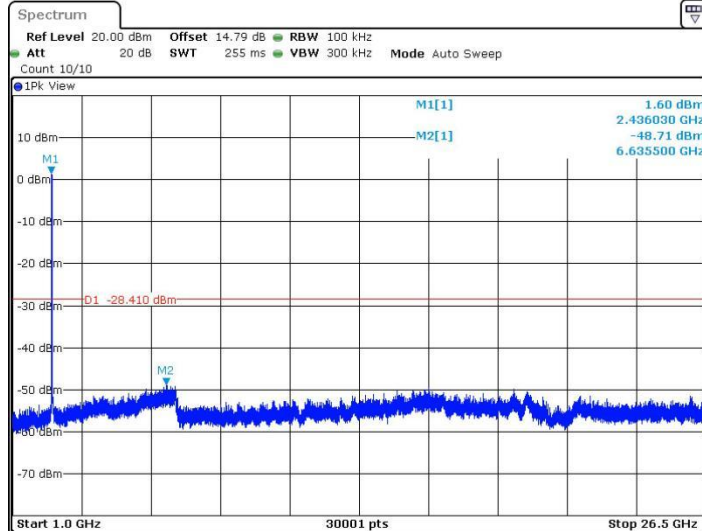

Date: 12.AUG.2024 10:53:38

11G_Ant1_2462_0~Reference

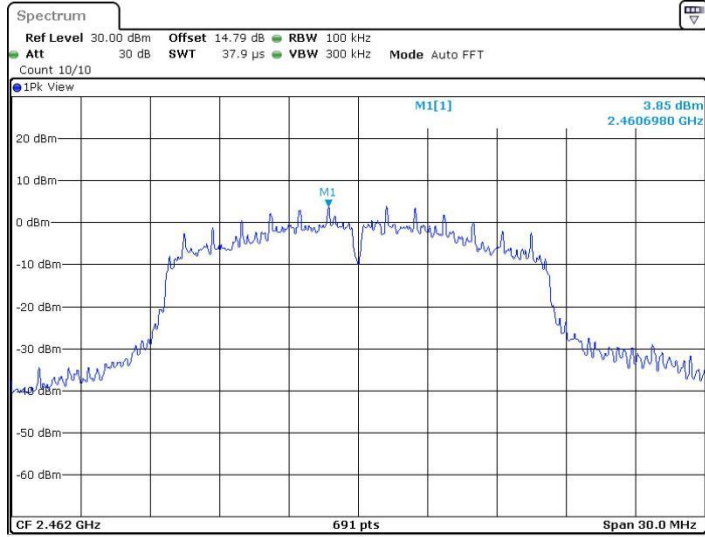

Date: 12 AUG 2024 10:54:53

11G_Ant1_2462_30~1000

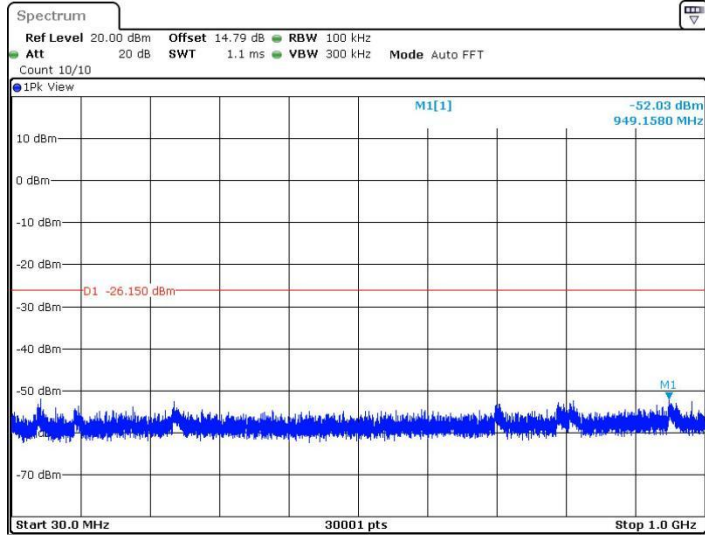

Date: 12 AUG 2024 10:54:59

11G_Ant1_2462_1000~26500

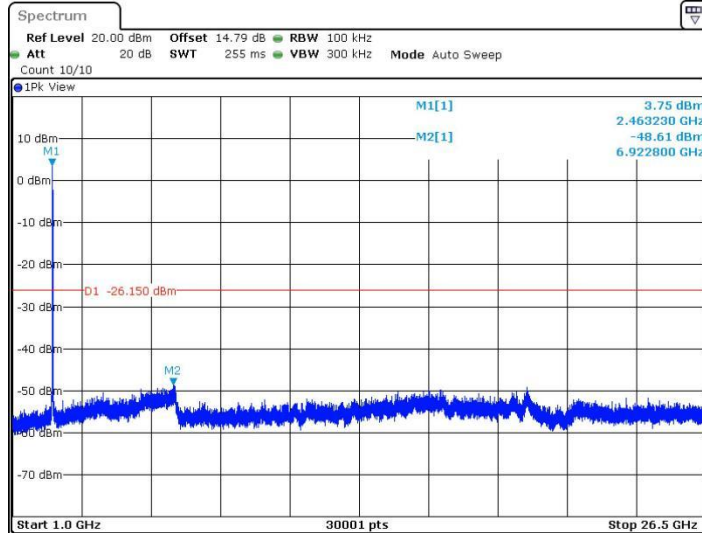

Date: 12.AUG.2024 10:55:21

11N20SISO_Ant1_2412_0~Reference

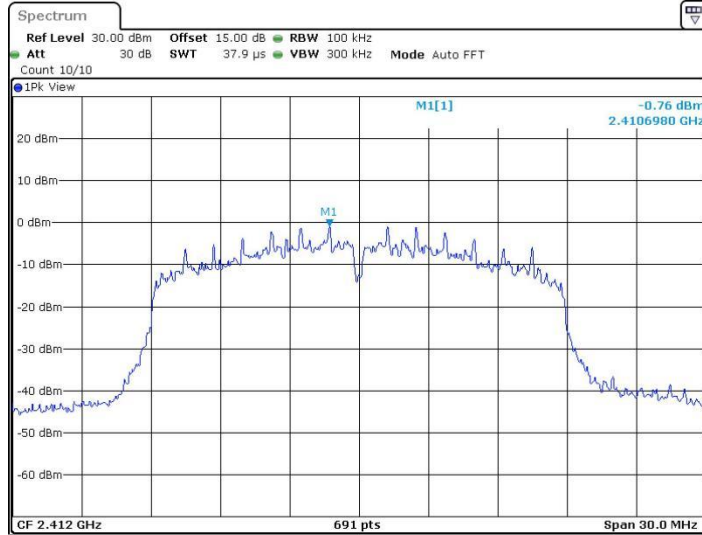

Date: 12.AUG.2024 10:56:56

11N20SISO_Ant1_2412_30~1000

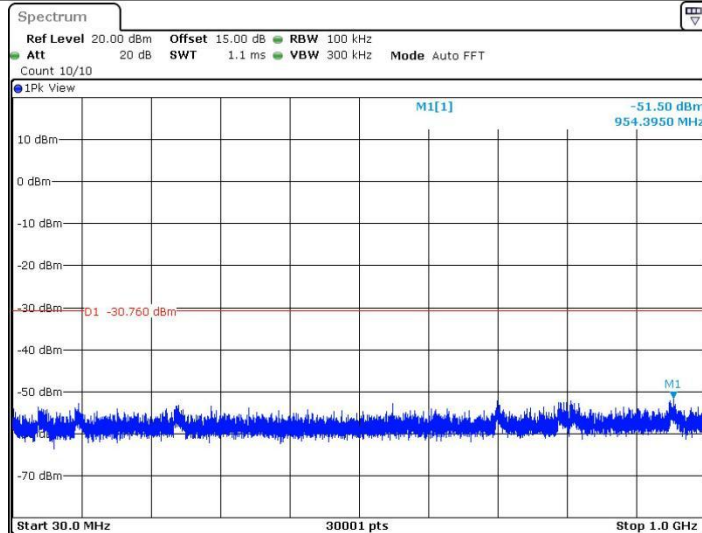

Date: 12.AUG.2024 10:57:02

11N20SISO_Ant1_2412_1000~26500

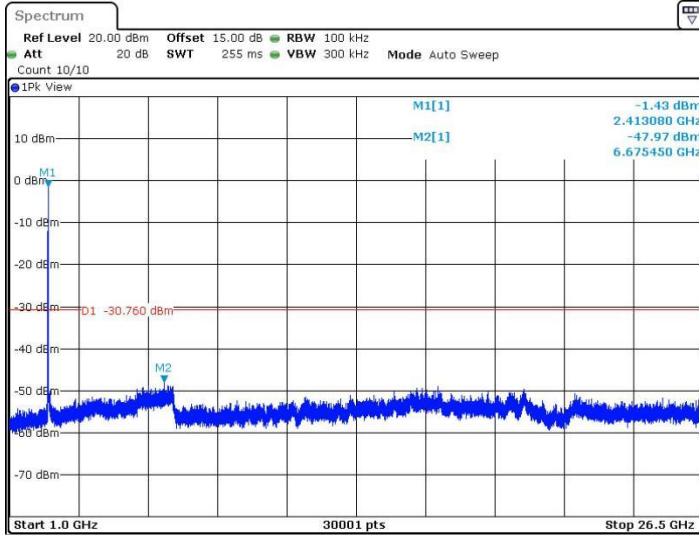

Date: 12 AUG.2024 10:57:25

11N20SISO_Ant1_2437_0~Reference

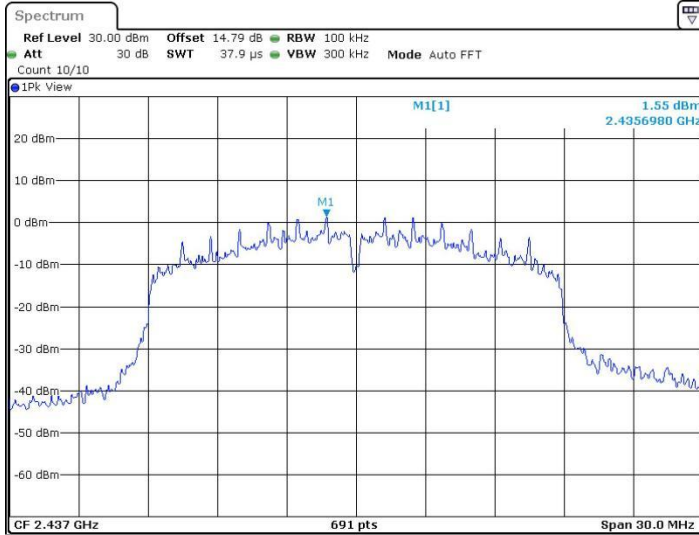

Date: 12 AUG.2024 10:58:41

11N20SISO_Ant1_2437_30~1000

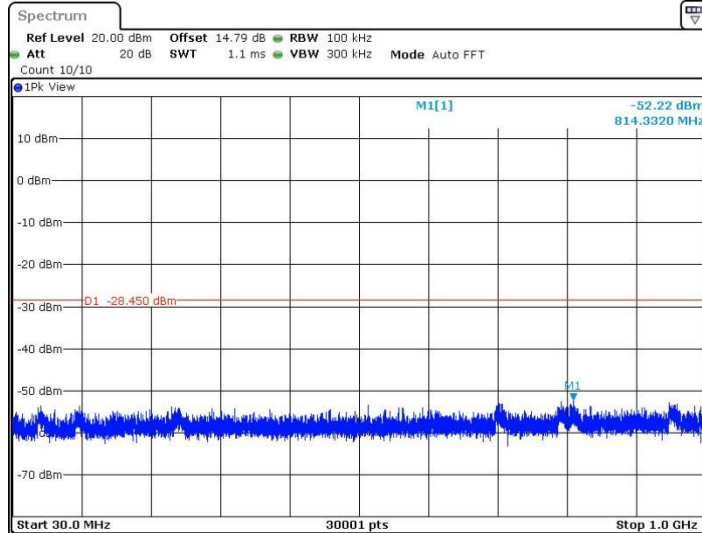

Date: 12.AUG.2024 10:58:47

11N20SISO_Ant1_2437_1000~26500

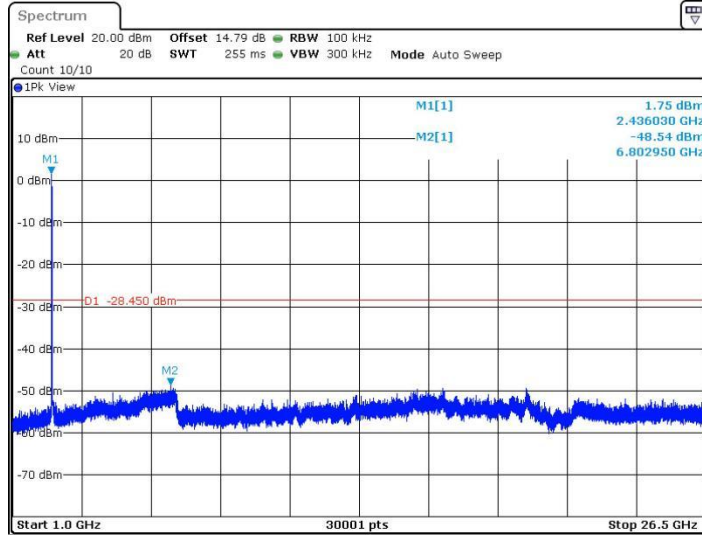

Date: 12.AUG.2024 10:59:09

11N20SISO_Ant1_2462_0~Reference

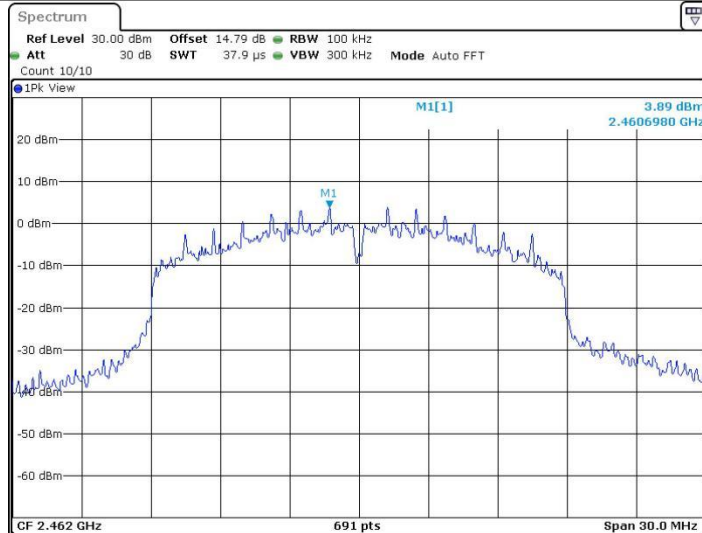

Date: 12.AUG.2024 11:03:51

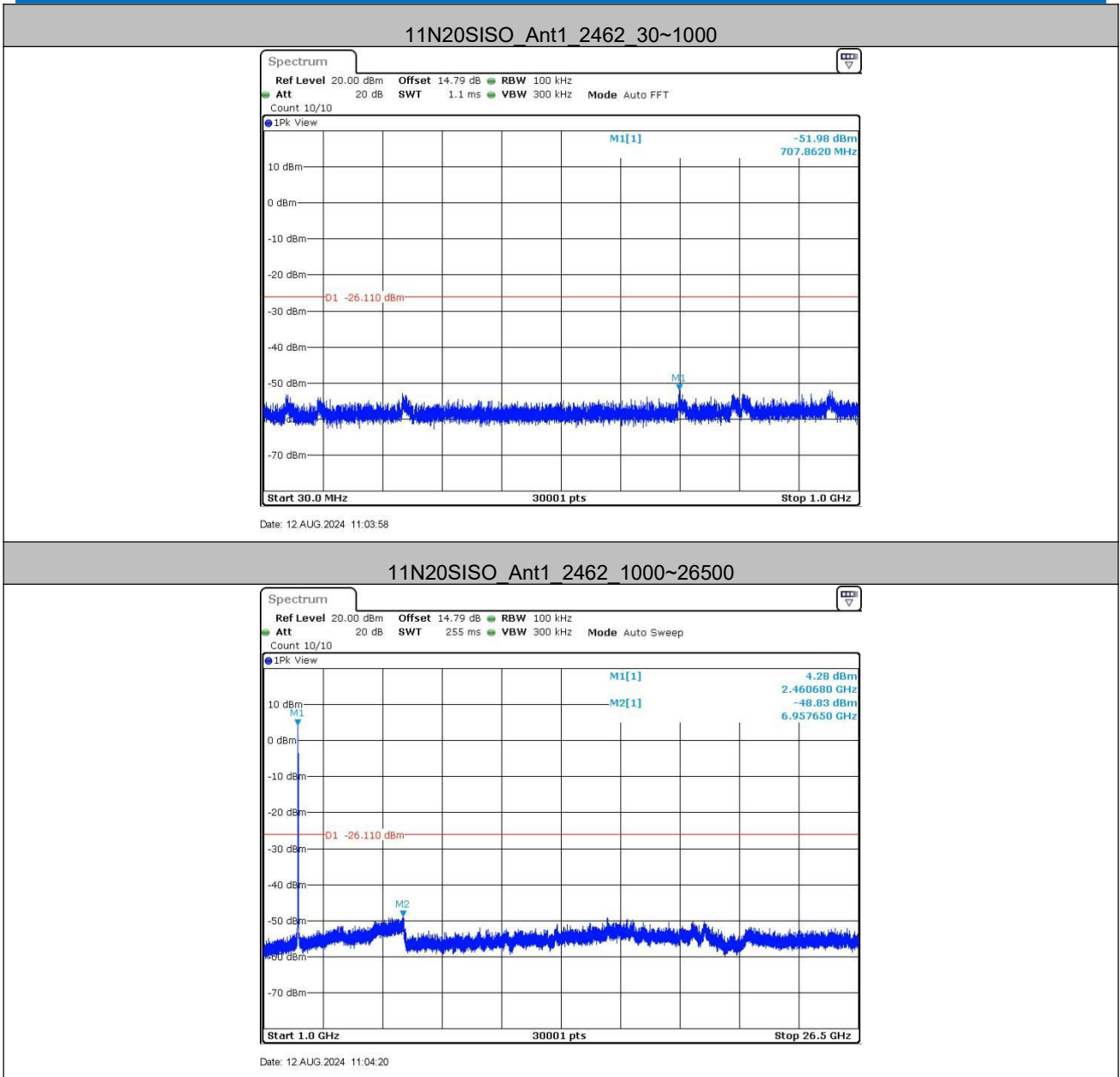

Remark:

Pretest 9kHz to 25GHz, find the highest point when testing, so only the worst data were shown in the test report. Per FCC Part 15.33 (a) and 15.31 (o) ,The amplitude of spurious emissions from intentional radiators which are attenuated more than 20 dB below the permissible value need not be reported unless specifically required elsewhere in this part.

5.8 Radiated Spurious Emissions

Test Requirement:	47 CFR Part 15C Section 15.209 and 15.205				
Test Method:	ANSI C63.10 2013				
Test Site:	Measurement Distance: 3m (Semi-Anechoic Chamber)				
Receiver Setup:	Frequency	Detector	RBW	VBW	Remark
	0.009MHz-0.090MHz	Peak	10kHz	30kHz	Peak
	0.009MHz-0.090MHz	Average	10kHz	30kHz	Average
	0.090MHz-0.110MHz	Quasi-peak	10kHz	30kHz	Quasi-peak
	0.110MHz-0.490MHz	Peak	10kHz	30kHz	Peak
	0.110MHz-0.490MHz	Average	10kHz	30kHz	Average
	0.490MHz -30MHz	Quasi-peak	10kHz	30kHz	Quasi-peak
	30MHz-1GHz	Quasi-peak	100 kHz	300kHz	Quasi-peak
	Above 1GHz	Peak	1MHz	3MHz	Peak
Peak		1MHz	10Hz	Average	
Limit:	Frequency	Field strength (microvolt/meter)	Limit (dBuV/m)	Remark	Measurement distance (m)
	0.009MHz-0.490MHz	2400/F(kHz)	-	-	300
	0.490MHz-1.705MHz	24000/F(kHz)	-	-	30
	1.705MHz-30MHz	30	-	-	30
	30MHz-88MHz	100	40.0	Quasi-peak	3
	88MHz-216MHz	150	43.5	Quasi-peak	3
	216MHz-960MHz	200	46.0	Quasi-peak	3
	960MHz-1GHz	500	54.0	Quasi-peak	3
	Above 1GHz	500	54.0	Average	3
<p>Note: 15.35(b), Unless otherwise specified, the limit on peak radio frequency emissions is 20dB above the maximum permitted average emission limit applicable to the equipment under test. This peak limit applies to the total peak emission level radiated by the device.</p>					

Test Setup:

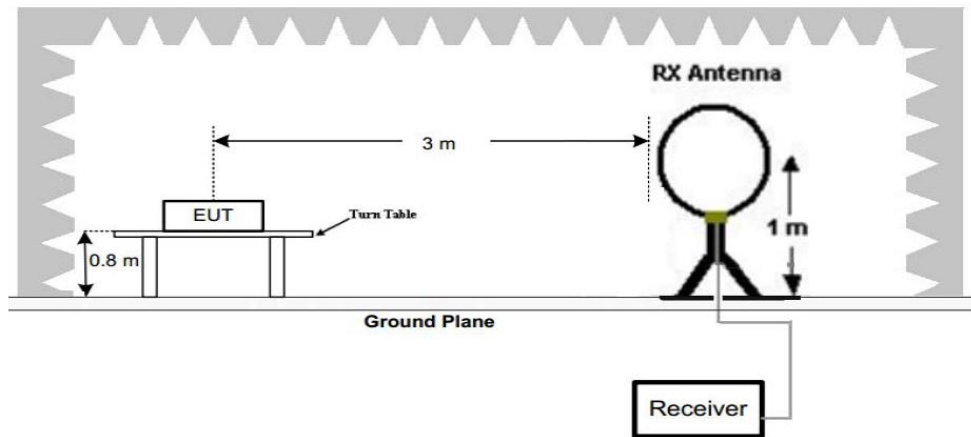

Figure 1. Below 30MHz

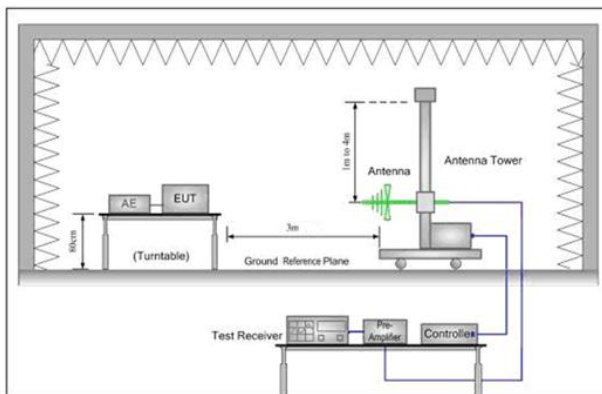

Figure 2. 30MHz to 1GHz

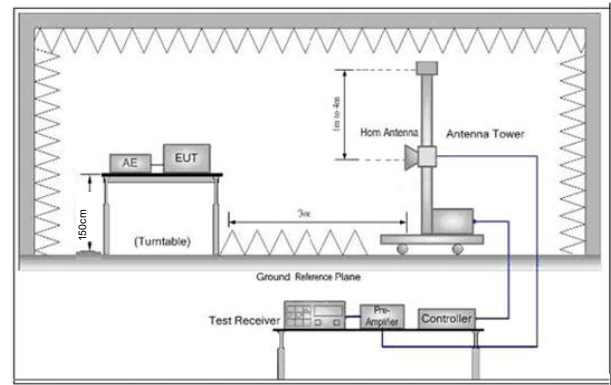

Figure 3. Above 1 GHz

Test Procedure:

- a. 1) Below 1G: The EUT was placed on the top of a rotating table 0.8 meters above the ground at a 3 meter semi-anechoic chamber. The table was rotated 360 degrees to determine the position of the highest radiation.
 2) Above 1G: The EUT was placed on the top of a rotating table 1.5 meters above the ground at a 3 meter semi-anechoic chamber. The table was rotated 360 degrees to determine the position of the highest radiation.
 Note: For the radiated emission test above 1GHz: Place the measurement antenna away from each area of the EUT determined to be a source of emissions at the specified measurement distance, while keeping the measurement antenna aimed at the source of emissions at each frequency of significant emissions, with polarization oriented for maximum response. The measurement antenna may have to be higher or lower than the EUT, depending on the radiation pattern of the emission and staying aimed at the emission source for receiving the maximum signal. The final measurement antenna elevation shall be that which maximizes the emissions. The measurement antenna elevation for maximum emissions shall be restricted to a range of heights of from 1 m to 4 m above the ground or reference ground plane.
- b. The EUT was set 3 meters away from the interference-receiving antenna, which was mounted on the top of a variable-height antenna tower.
- c. The antenna height is varied from one meter to four meters above the ground to determine the maximum value of the field strength. Both horizontal and vertical polarizations of the antenna are set to make the measurement.

	<ul style="list-style-type: none"> d. For each suspected emission, the EUT was arranged to its worst case and then the antenna was tuned to heights from 1 meter to 4 meters(for the test frequency of below 30MHz, the antenna was tuned to heights 1 meter) and the rotatable table was turned from 0 degrees to 360 degrees to find the maximum reading. e. The test-receiver system was set to Peak Detect Function and Specified Bandwidth with Maximum Hold Mode. f. If the emission level of the EUT in peak mode was 10dB lower than the limit specified, then testing could be stopped and the peak values of the EUT would be reported. Otherwise the emissions that did not have 10dB margin would be re-tested one by one using peak, quasi-peak or average method as specified and then reported in a data sheet. g. Test the EUT in the lowest channel, the middle channel, the Highest channel. h. The radiation measurements are performed in X, Y, Z axis positioning for Transmitting mode,And found the X axis positioning which it is worse case . i. Repeat above procedures until all frequencies measured was complete.
Exploratory Test Mode:	Transmitting with all kind of modulations, data rates at lowest, middle and highest channel.
Final Test Mode:	Only the worst case is recorded in the report.
Test Results:	Pass

5.8.1 Radiated emission below 1GHz

30MHz~1GHz
Vertical

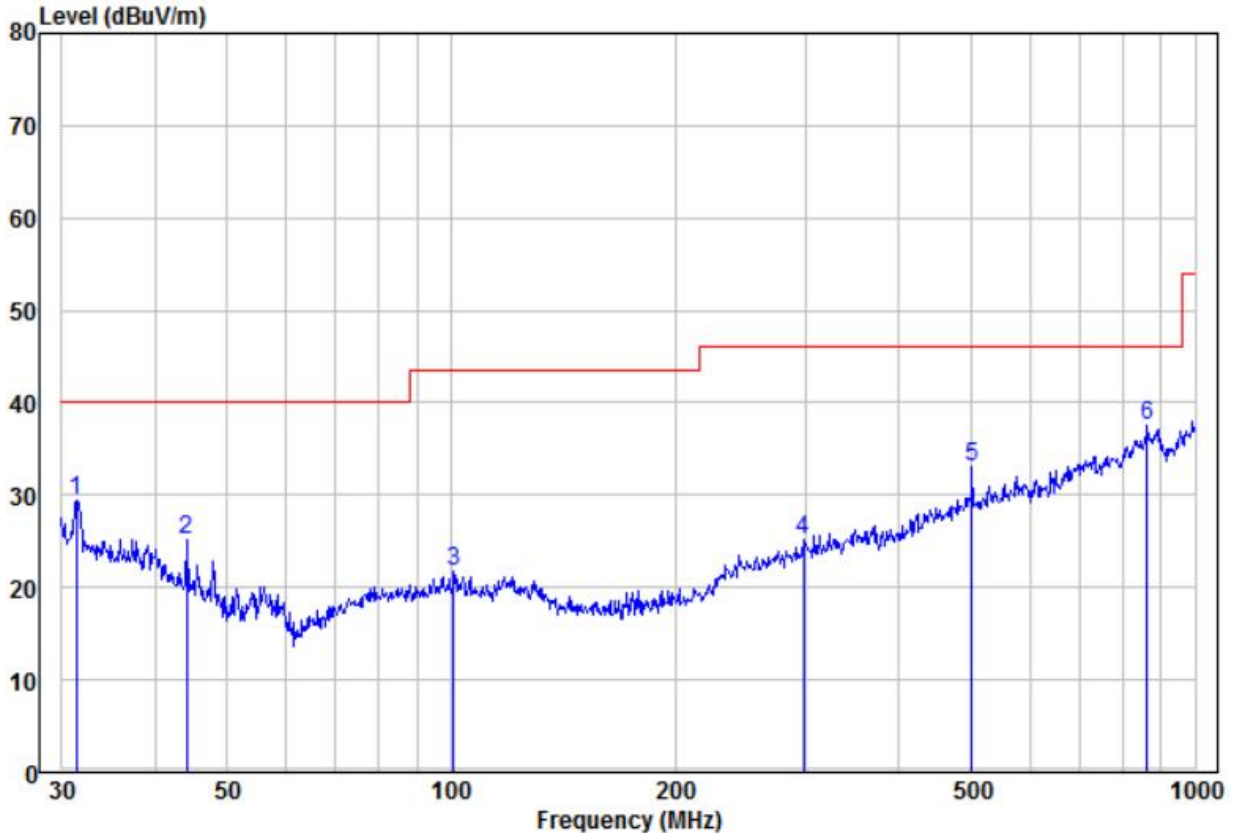

	Read	Limit	Over				
Freq	Level	Factor	Level	Line	Limit	Remark	Pol/Phase
MHz	dBuV	dB/m	dBuV/m	dBuV/m	dB		
1	31.40	13.64	15.79	29.43	40.00	-10.57 Peak	VERTICAL
2	44.12	13.53	11.54	25.07	40.00	-14.93 Peak	VERTICAL
3	100.93	9.94	11.72	21.66	43.50	-21.84 Peak	VERTICAL
4	297.22	9.85	15.22	25.07	46.00	-20.93 Peak	VERTICAL
5	501.18	12.83	20.31	33.14	46.00	-12.86 Peak	VERTICAL
6 pp	863.06	10.72	26.79	37.51	46.00	-8.49 Peak	VERTICAL

Remark:

The field strength is calculated by adding the Antenna Factor, Cable Factor & Preamplifier. The basic equation with a sample calculation is as follows:

Factor= Antenna Factor + Cable Factor – Preamplifier Factor,

Level = Read Level + Factor,

Over Limit=Level-Limit Line.

Horizontal

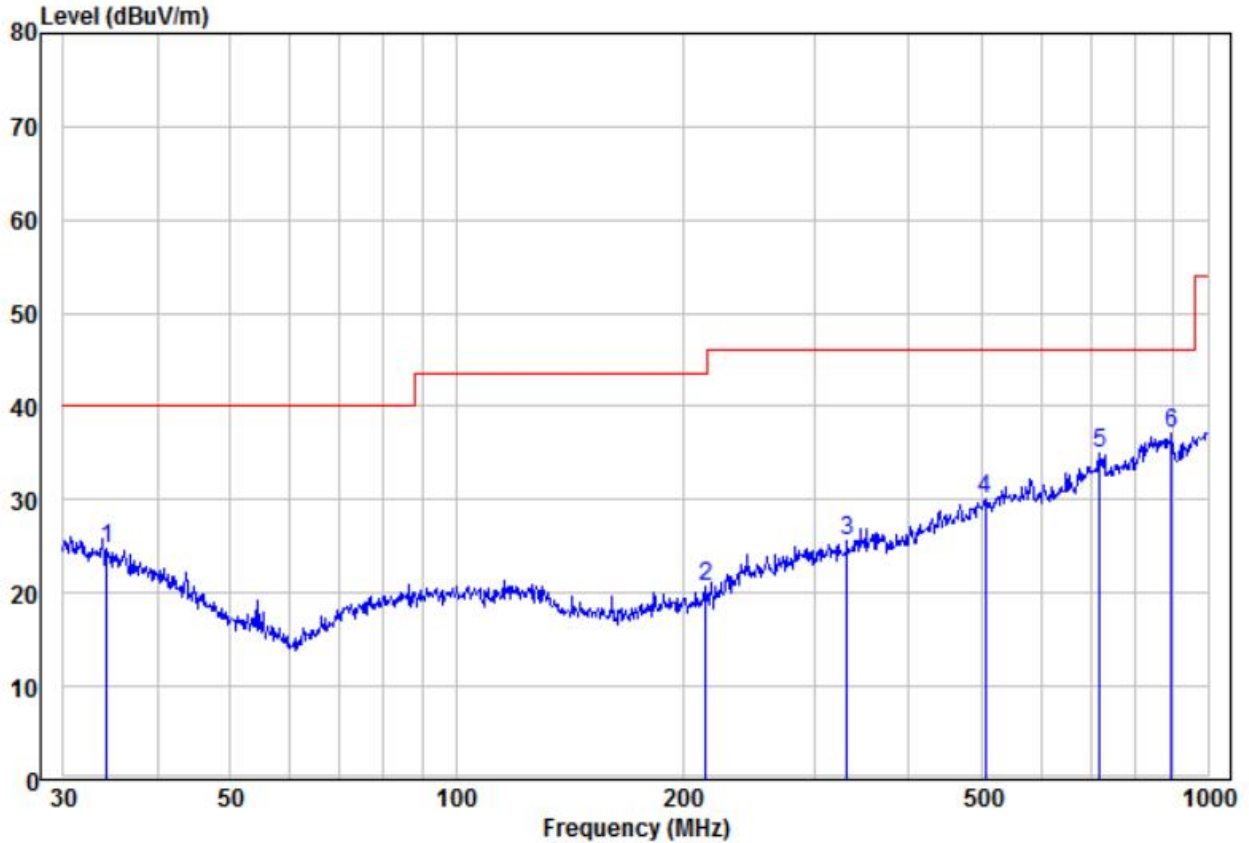

	Read Freq	Read Level	Factor	Level	Limit Line	Over Limit	Remark	Pol/Phase
	MHz	dBuV	dB/m	dBuV/m	dBuV/m	dB		
1	34.28	9.53	15.18	24.71	40.00	-15.29	Peak	HORIZONTAL
2	214.51	10.16	10.47	20.63	43.50	-22.87	Peak	HORIZONTAL
3	331.35	9.53	16.13	25.66	46.00	-20.34	Peak	HORIZONTAL
4	506.48	9.74	20.39	30.13	46.00	-15.87	Peak	HORIZONTAL
5	719.20	11.57	23.51	35.08	46.00	-10.92	Peak	HORIZONTAL
6 pp	893.86	10.42	26.73	37.15	46.00	-8.85	Peak	HORIZONTAL

Remark:

The field strength is calculated by adding the Antenna Factor, Cable Factor & Preamplifier. The basic equation with a sample calculation is as follows:

Factor= Antenna Factor + Cable Factor – Preamplifier Factor,

Level = Read Level + Factor,

Over Limit=Level-Limit Line.

5.8.2 Transmitter emission above 1GHz

Test mode:		802.11b(1Mbps)		Test channel:		Lowest	
Frequency	Meter Reading	Factor	Emission Level	Limits	Over	Detector Type	Ant. Pol.
(MHz)	(dB μ V)	(dB)	(dB μ V/m)	(dB μ V/m)	(dB)		H/V
4824.000	52.98	-4.26	48.72	74	-25.28	peak	H
4824.000	37.26	-4.26	33.00	54	-21.00	AVG	H
7236.000	50.25	1.18	51.43	74	-22.57	peak	H
7236.000	38.64	1.18	39.82	54	-14.18	AVG	H
4824.000	55.11	-4.26	50.85	74	-23.15	peak	V
4824.000	39.62	-4.26	35.36	54	-18.64	AVG	V
7236.000	51.92	1.18	53.10	74	-20.90	peak	V
7236.000	36.16	1.18	37.34	54	-16.66	AVG	V

Test mode:		802.11b(1Mbps)		Test channel:		Middle	
Frequency	Meter Reading	Factor	Emission Level	Limits	Over	Detector Type	Ant. Pol.
(MHz)	(dB μ V)	(dB)	(dB μ V/m)	(dB μ V/m)	(dB)		H/V
4874.000	51.69	-4.12	47.57	74	-26.43	peak	H
4874.000	36.47	-4.12	32.35	54	-21.65	AVG	H
7311.000	49.35	1.46	50.81	74	-23.19	peak	H
7311.000	35.33	1.46	36.79	54	-17.21	AVG	H
4874.000	53.67	-4.12	49.55	74	-24.45	peak	V
4874.000	37.72	-4.12	33.60	54	-20.40	AVG	V
7311.000	48.52	1.46	49.98	74	-24.02	peak	V
7311.000	36.95	1.46	38.41	54	-15.59	AVG	V

Test mode:		802.11b(1Mbps)		Test channel:		Highest	
Frequency	Meter Reading	Factor	Emission Level	Limits	Over	Detector Type	Ant. Pol.
(MHz)	(dBμV)	(dB)	(dBμV/m)	(dBμV/m)	(dB)		H/V
4924.000	52.82	-4.03	48.79	74	-25.21	peak	H
4924.000	37.41	-4.03	33.38	54	-20.62	AVG	H
7386.000	50.93	1.66	52.59	74	-21.41	peak	H
7386.000	37.14	1.66	38.80	54	-15.20	AVG	H
4924.000	53.90	-4.03	49.87	74	-24.13	peak	V
4924.000	38.62	-4.03	34.59	54	-19.41	AVG	V
7386.000	50.73	1.66	52.39	74	-21.61	peak	V
7386.000	37.88	1.66	39.54	54	-14.46	AVG	V

Remark:

- 1) The 1Mbps of rate of 802.11b is the worst case.
- 2) The field strength is calculated by adding the Antenna Factor, Cable Factor & Preamplifier. The basic equation with a sample calculation is as follows:
Final Test Level = Receiver Reading + Antenna Factor + Cable Factor – Preamplifier Factor
- 3) Scan from 9kHz to 25GHz, The disturbance above 13GHz and below 30MHz was very low, and the above harmonics were the highest point could be found when testing, so only the above harmonics had been displayed. The amplitude of spurious emissions from the radiator which are attenuated more than 20dB below the limit need not be reported.

Test mode:		802.11g(6Mbps)		Test channel:		Lowest	
Frequency	Meter Reading	Factor	Emission Level	Limits	Over	Detector Type	Ant. Pol.
(MHz)	(dBμV)	(dB)	(dBμV/m)	(dBμV/m)	(dB)		H/V
4824.000	53.21	-4.26	48.95	74	-25.05	peak	H
4824.000	36.73	-4.26	32.47	54	-21.53	AVG	H
7236.000	50.56	1.18	51.74	74	-22.26	peak	H
7236.000	38.88	1.18	40.06	54	-13.94	AVG	H
4824.000	54.48	-4.26	50.22	74	-23.78	peak	V
4824.000	38.15	-4.26	33.89	54	-20.11	AVG	V
7236.000	51.43	1.18	52.61	74	-21.39	peak	V
7236.000	35.67	1.18	36.85	54	-17.15	AVG	V

Test mode:		802.11g(6Mbps)		Test channel:		Middle	
Frequency	Meter Reading	Factor	Emission Level	Limits	Over	Detector Type	Ant. Pol.
(MHz)	(dBμV)	(dB)	(dBμV/m)	(dBμV/m)	(dB)		H/V
4874.000	53.01	-4.12	48.89	74	-25.11	peak	H
4874.000	37.35	-4.12	33.23	54	-20.77	AVG	H
7311.000	48.97	1.46	50.43	74	-23.57	peak	H
7311.000	35.79	1.46	37.25	54	-16.75	AVG	H
4874.000	53.05	-4.12	48.93	74	-25.07	peak	V
4874.000	37.05	-4.12	32.93	54	-21.07	AVG	V
7311.000	50.01	1.46	51.47	74	-22.53	peak	V
7311.000	35.09	1.46	36.55	54	-17.45	AVG	V

Test mode:		802.11g(6Mbps)		Test channel:		Highest	
Frequency	Meter Reading	Factor	Emission Level	Limits	Over	Detector Type	Ant. Pol.
(MHz)	(dBμV)	(dB)	(dBμV/m)	(dBμV/m)	(dB)		H/V
4924.000	52.90	-4.03	48.87	74	-25.13	peak	H
4924.000	37.71	-4.03	33.68	54	-20.32	AVG	H
7386.000	50.05	1.66	51.71	74	-22.29	peak	H
7386.000	37.49	1.66	39.15	54	-14.85	AVG	H
4924.000	53.40	-4.03	49.37	74	-24.63	peak	V
4924.000	37.10	-4.03	33.07	54	-20.93	AVG	V
7386.000	50.92	1.66	52.58	74	-21.42	peak	V
7386.000	36.91	1.66	38.57	54	-15.43	AVG	V

Remark:

- 1) The 6Mbps of rate of 802.11g is the worst case.
- 2) The field strength is calculated by adding the Antenna Factor, Cable Factor & Preamplifier. The basic equation with a sample calculation is as follows:
Final Test Level = Receiver Reading + Antenna Factor + Cable Factor – Preamplifier Factor
- 3) Scan from 9kHz to 25GHz, The disturbance above 13GHz and below 30MHz was very low, and the above harmonics were the highest point could be found when testing, so only the above harmonics had been displayed. The amplitude of spurious emissions from the radiator which are attenuated more than 20dB below the limit need not be reported.