

TEST REPORT

Application No.: SZCR2504001607WM
Applicant: Realme Chongqing Mobile Telecommunications Corp., Ltd.
Address of Applicant: No.178 Yulong Avenue, Yufengshan, Yubei District, Chongqing, China
Manufacturer: Realme Chongqing Mobile Telecommunications Corp., Ltd.
Address of Manufacturer: No.178 Yulong Avenue, Yufengshan, Yubei District, Chongqing, China
Equipment Under Test (EUT):
EUT Name: Mobile Phone
Model No.: RMX5101
Trade Mark: realme
FCC ID: 2AUYFRMX5101
Standard(s) : 47 CFR Part 15, Subpart E 15.407
Date of Receipt: 2025-04-23
Date of Test: 2025-05-20 to 2025-06-25
Date of Issue: 2025-06-25

Test Result:	Pass*
---------------------	--------------

* In the configuration tested, the EUT complied with the standards specified above.

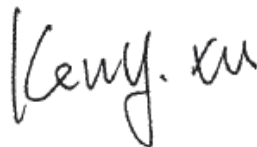

Keny Xu
EMC Laboratory Manager



Revision Record				
Version	Chapter	Date	Modifier	Remark
01		2025-06-25		Original

Authorized for issue by:			
		<i>Sherlock Fang</i>	
		Sherlock Fang/Project Engineer	
		<i>Eric Fu</i>	
		Eric Fu/Reviewer	



Unless otherwise agreed in writing, this document is issued by the Company subject to its General Conditions of Service printed overleaf, available on request or accessible at <https://www.sgs.com/en/Terms-and-Conditions>. Attention is drawn to the limitation of liability, indemnification and jurisdiction issues defined therein. Any holder of this document is advised that information contained hereon reflects the Company's findings at the time of its intervention only and within the limits of Client's instructions, if any. The Company's sole responsibility is to its Client and this document does not exonerate parties to a transaction from exercising all their rights and obligations under the transaction documents. This document cannot be reproduced except in full, without prior written approval of the Company. Any unauthorized alteration, forgery or falsification of the content or appearance of this document is unlawful and offenders may be prosecuted to the fullest extent of the law. Unless otherwise stated the results shown in this test report refer only to the sample(s) tested and such sample(s) are retained for 30 days only.

Attention: To check the authenticity of testing /inspection report & certificate, please contact us at telephone: (86-755) 8307 1443, or email: CN.Doccheck@sgs.com

2 Test Summary

Radio Spectrum Technical Requirement				
Item	Standard	Method	Requirement	Result
Antenna Requirement	47 CFR Part 15, Subpart E 15.407	N/A	47 CFR Part 15, Subpart C 15.203	Pass
Transmission in the Absence of Data		N/A	47 CFR Part 15, Subpart E 15.407 (c)	Pass

Radio Spectrum Matter Part				
Item	Standard	Method	Requirement	Result
Conducted Emissions at AC Power Line (150kHz-30MHz)	47 CFR Part 15, Subpart E 15.407	ANSI C63.10 (2013) Section 6.2	47 CFR Part 15, Subpart C 15.207 & Subpart E 15.407 b(9)	Pass
Maximum Conducted output power		ANSI C63.10 (2013) Section 12.3	47 CFR Part 15, Subpart E 15.407 (a)	Pass
Radiated Emissions (Below 1GHz)		ANSI C63.10 (2013) Section 6.4,6.5	47 CFR Part 15, Subpart C 15.209 & Subpart E 15.407(b)	Pass
Radiated Emissions (Above 1GHz)		ANSI C63.10 (2013) Section 6.6	47 CFR Part 15, Subpart C 15.209 & Subpart E 15.407(b)	Pass
Radiated Emissions which fall in the restricted bands		ANSI C63.10 (2013) Section 6.10.5	47 CFR Part 15, Subpart C 15.209 & Subpart E 15.407(b)	Pass
Channel Move Time		KDB 905462 D02 Section 7.8.3	KDB 905462 D02 Section 5.1	Pass
Duty Cycle		ANSI C63.10 (2013) Section 12.2	ANSI C63.10 (2013) Section 12.2	Pass
99% Bandwidth		ANSI C63.10 (2013) Section 12.4.2	ANSI C63.10 (2013) Section 12.4.2	Pass
26dB Emission bandwidth		ANSI C63.10 (2013) Section 12.4.1	47 CFR Part 15, Subpart E 15.407 (a)	Pass
Minimum 6 dB bandwidth (5.725-5.85 GHz band)		ANSI C63.10 (2013) Section 6.9.2	47 CFR Part 15, Subpart E 15.407 (e)	Pass
Peak Power spectrum density		ANSI C63.10 (2013) Section 12.5	47 CFR Part 15, Subpart E 15.407 (a)	Pass
Frequency Stability		ANSI C63.10 (2013) Section 6.8	47 CFR Part 15, Subpart E 15.407 (g)	Pass
Non-occupancy period		KDB 905462 D02 Section 7.8.3	KDB 905462 D02 Section 5.1	Pass
Channel Closing Transmission Time		KDB 905462 D02 Section 7.8.3	KDB 905462 D02 Section 5.1	Pass



Unless otherwise agreed in writing, this document is issued by the Company subject to its General Conditions of Service printed overleaf, available on request or accessible at <https://www.sgs.com/en/Terms-and-Conditions>. Attention is drawn to the limitation of liability, indemnification and jurisdiction issues defined therein. Any holder of this document is advised that information contained hereon reflects the Company's findings at the time of its intervention only and within the limits of Client's instructions, if any. The Company's sole responsibility is to its Client and this document does not exonerate parties to a transaction from exercising all their rights and obligations under the transaction documents. This document cannot be reproduced except in full, without prior written approval of the Company. Any unauthorized alteration, forgery or falsification of the content or appearance of this document is unlawful and offenders may be prosecuted to the fullest extent of the law. Unless otherwise stated the results shown in this test report refer only to the sample(s) tested and such sample(s) are retained for 30 days only.

Attention: To check the authenticity of testing /inspection report & certificate, please contact us at telephone: (86-755) 8307 1443, or email: CN.Doccheck@sgs.com

3 Contents

	Page
1 Cover Page	1
2 Test Summary	3
3 Contents	4
4 General Information	7
4.1 Details of E.U.T.	7
4.2 Environment Parameter	8
4.3 Description of Support Units	9
4.4 Measurement Uncertainty	9
4.5 Test Location.....	10
4.6 Test Facility	10
4.7 Deviation from Standards.....	10
4.8 Abnormalities from Standard Conditions	10
5 Equipment List	11
6 Radio Spectrum Technical Requirement	14
6.1 Antenna Requirement	14
6.1.1 Test Requirement:	14
6.1.2 Conclusion	14
6.2 Transmission in the Absence of Data	16
6.2.1 Test Requirement:	16
6.2.2 Conclusion	16
7 Radio Spectrum Matter Test Results	17
7.1 Conducted Emissions at AC Power Line (150kHz-30MHz).....	17
7.1.1 E.U.T. Operation	17
7.1.2 Test Mode Description	17
7.1.3 Test Setup Diagram	18
7.1.4 Measurement Procedure and Data.....	18
7.2 Maximum Conducted output power	21
7.2.1 E.U.T. Operation	21
7.2.2 Test Mode Description	21
7.2.3 Test Setup Diagram	22
7.2.4 Measurement Procedure and Data.....	22
7.3 Radiated Emissions (Below 1GHz).....	23
7.3.1 E.U.T. Operation	23
7.3.2 Test Mode Description	23
7.3.3 Test Setup Diagram	24
7.3.4 Measurement Procedure and Data.....	25
7.4 Radiated Emissions (Above 1GHz).....	34
7.4.1 E.U.T. Operation	34



Unless otherwise agreed in writing, this document is issued by the Company subject to its General Conditions of Service printed overleaf, available on request or accessible at <https://www.sgs.com/en/Terms-and-Conditions>. Attention is drawn to the limitation of liability, indemnification and jurisdiction issues defined therein. Any holder of this document is advised that information contained hereon reflects the Company's findings at the time of its intervention only and within the limits of Client's instructions, if any. The Company's sole responsibility is to its Client and this document does not exonerate parties to a transaction from exercising all their rights and obligations under the transaction documents. This document cannot be reproduced except in full, without prior written approval of the Company. Any unauthorized alteration, forgery or falsification of the content or appearance of this document is unlawful and offenders may be prosecuted to the fullest extent of the law. Unless otherwise stated the results shown in this test report refer only to the sample(s) tested and such sample(s) are retained for 30 days only.

Attention: To check the authenticity of testing /inspection report & certificate, please contact us at telephone: (86-755) 8307 1443, or email: CN.Doccheck@sgs.com

7.4.2	Test Mode Description	35
7.4.3	Test Setup Diagram	35
7.4.4	Measurement Procedure and Data	36
7.5	Radiated Emissions which fall in the restricted bands	85
7.5.1	E.U.T. Operation	85
7.5.2	Test Mode Description	86
7.5.3	Test Setup Diagram	86
7.5.4	Measurement Procedure and Data	87
7.6	Channel Move Time	226
7.6.1	E.U.T. Operation	226
7.6.2	Test Mode Description	227
7.6.3	Test Setup Diagram	227
7.6.4	Measurement Procedure and Data	228
7.7	Duty Cycle	229
7.7.1	E.U.T. Operation	229
7.7.2	Test Mode Description	229
7.7.3	Test Setup Diagram	229
7.7.4	Measurement Procedure and Data	229
7.8	99% Bandwidth	230
7.8.1	E.U.T. Operation	230
7.8.2	Test Mode Description	230
7.8.3	Test Setup Diagram	230
7.8.4	Measurement Procedure and Data	230
7.9	26dB Emission bandwidth	231
7.9.1	E.U.T. Operation	231
7.9.2	Test Mode Description	231
7.9.3	Test Setup Diagram	231
7.9.4	Measurement Procedure and Data	231
7.10	Minimum 6 dB bandwidth (5.725-5.85 GHz band)	232
7.10.1	E.U.T. Operation	232
7.10.2	Test Mode Description	232
7.10.3	Test Setup Diagram	232
7.10.4	Measurement Procedure and Data	232
7.11	Peak Power spectrum density	233
7.11.1	E.U.T. Operation	233
7.11.2	Test Mode Description	233
7.11.3	Test Setup Diagram	234
7.11.4	Measurement Procedure and Data	234
7.12	Frequency Stability	235
7.12.1	E.U.T. Operation	235
7.12.2	Test Mode Description	235
7.12.3	Test Setup Diagram	235
7.12.4	Measurement Procedure and Data	235
7.13	Non-occupancy period	236
7.13.1	E.U.T. Operation	236
7.13.2	Test Mode Description	237
7.13.3	Test Setup Diagram	237
7.13.4	Measurement Procedure and Data	238
7.14	Channel Closing Transmission Time	239
7.14.1	E.U.T. Operation	239



Unless otherwise agreed in writing, this document is issued by the Company subject to its General Conditions of Service printed overleaf, available on request or accessible at <https://www.sgs.com/en/Terms-and-Conditions>. Attention is drawn to the limitation of liability, indemnification and jurisdiction issues defined therein. Any holder of this document is advised that information contained hereon reflects the Company's findings at the time of its intervention only and within the limits of Client's instructions, if any. The Company's sole responsibility is to its Client and this document does not exonerate parties to a transaction from exercising all their rights and obligations under the transaction documents. This document cannot be reproduced except in full, without prior written approval of the Company. Any unauthorized alteration, forgery or falsification of the content or appearance of this document is unlawful and offenders may be prosecuted to the fullest extent of the law. Unless otherwise stated the results shown in this test report refer only to the sample(s) tested and such sample(s) are retained for 30 days only.

Attention: To check the authenticity of testing /inspection report & certificate, please contact us at telephone: (86-755) 8307 1443, or email: CN.Doccheck@sgs.com

SGS-CSTC Standards Technical Services Co., Ltd. Shenzhen Branch

SZEMC-TRF-01 Rev. A/1

Report No.: SZCR250400160706

Page: 6 of 556

7.14.2	Test Mode Description.....	240
7.14.3	Test Setup Diagram.....	240
7.14.4	Measurement Procedure and Data.....	241
8	Test Setup Photo	242
9	EUT Constructional Details (EUT Photos)	242
10	Appendix.....	243



Unless otherwise agreed in writing, this document is issued by the Company subject to its General Conditions of Service printed overleaf, available on request or accessible at <https://www.sgs.com/en/Terms-and-Conditions>. Attention is drawn to the limitation of liability, indemnification and jurisdiction issues defined therein. Any holder of this document is advised that information contained hereon reflects the Company's findings at the time of its intervention only and within the limits of Client's instructions, if any. The Company's sole responsibility is to its Client and this document does not exonerate parties to a transaction from exercising all their rights and obligations under the transaction documents. This document cannot be reproduced except in full, without prior written approval of the Company. Any unauthorized alteration, forgery or falsification of the content or appearance of this document is unlawful and offenders may be prosecuted to the fullest extent of the law. Unless otherwise stated the results shown in this test report refer only to the sample(s) tested and such sample(s) are retained for 30 days only.

Attention: To check the authenticity of testing /inspection report & certificate, please contact us at telephone: (86-755) 8307 1443, or email: CN.Doccheck@sgs.com

4 General Information

4.1 Details of E.U.T.

EUT Description:	Mobile Phone	
Model No.:	RMX5101	
Trade Mark:	realme	
Hardware Version:	11	
Software Version:	realme UI 6.0	
Power Supply:	DC 3.83V from internal rechargeable battery which can be charge by AC/DC adapter	
WLAN Mode Supported:	802.11a:	20 MHz channel bandwidth
	802.11n:	20 MHz / 40 MHz channel bandwidth
	802.11ac:	20 MHz / 40 MHz / 80 MHz / 160 MHz channel bandwidth
	802.11ax:	20 MHz / 40 MHz / 80 MHz / 160 MHz channel bandwidth
Operation Frequency:	5150MHz to 5250MHz	
	5250MHz to 5350MHz	
	5470MHz to 5725MHz	
	5725MHz to 5850MHz	
Modulation Type:	802.11a:	OFDM (BPSK, QPSK, 16QAM, 64QAM)
	802.11n:	OFDM (BPSK, QPSK, 16QAM, 64QAM)
	802.11ac:	OFDM (BPSK, QPSK, 16QAM, 64QAM, 256QAM)
	802.11ax:	OFDM/OFDMA (BPSK, QPSK, 16QAM, 64QAM, 256QAM, 3.454QAM)
Channel Spacing:	20MHz:	802.11a/n(HT20)/ac(VHT20)/ax(HE20)
	40MHz:	802.11n(HT40)/ac(VHT40)/ax(HE40)
	80MHz:	802.11ac(VHT80)/ax(HE80)
	160MHz:	802.11ac(VHT160)/ax(HE160)
RU Allocation:	Not support	
Antenna Type:	Fixed Internal Antenna	
Antenna Gain:	5150MHz to 5250MHz: 0.3dBi(Ant9); -0.1dBi(Ant10); 5250MHz to 5350MHz: 0.1dBi(Ant9); 0.8dBi(Ant10); 5470MHz to 5725MHz: -1.3dBi(Ant9); 1.6dBi(Ant10); 5725MHz to 5850MHz: -2.5dBi(Ant9); 0.8dBi(Ant10);	
	Note: The antenna gain are derived from the gain information report provided by the manufacturer.	
Smart System:	<input checked="" type="checkbox"/> SISO	802.11a/n/ac/ax



	<input checked="" type="checkbox"/> MIMO	802.11a/n/ac/lax: 2Tx & 2Rx	
	<input checked="" type="checkbox"/> Diversity	CDD:802.11a: 2Tx & 2Rx	
TPC Function:	<input type="checkbox"/> Support, <input checked="" type="checkbox"/> Not Support		
DFS Function:	<input type="checkbox"/> Master		
	<input type="checkbox"/> Slave with radar detection	<input checked="" type="checkbox"/> Slave without radar detection	
RF Cable:	4900MHz ~ 5250MHz(1.6dB)		5250MHz ~ 5350MHz(1.7dB)
	5470MHz ~ 5725MHz(1.8dB)		5725MHz ~ 5850MHz (2dB)
<p>Remark:</p> <p>As above information is provided and confirmed by the applicant. SGS is not liable to the accuracy, suitability, reliability or/and integrity of the information.</p>			

4.2 Environment Parameter

Environment Parameter	1020 mbar Selected Values During Tests	
Relative Humidity	40.2-50.9 % RH Ambient	
Value	Temperature(°C)	Voltage(V)
NTNV	22.5~25.6	3.83
<p>Note:</p> <p>NV:Normal Voltage LV:Low Extreme Test Voltage HV:High Extreme Test Voltage</p> <p>NT:Normal Temperature LT:Low Extreme Test Temperature HT:High Extreme Test Temperature</p>		



Unless otherwise agreed in writing, this document is issued by the Company subject to its General Conditions of Service printed overleaf, available on request or accessible at <https://www.sgs.com/en/Terms-and-Conditions>. Attention is drawn to the limitation of liability, indemnification and jurisdiction issues defined therein. Any holder of this document is advised that information contained hereon reflects the Company's findings at the time of its intervention only and within the limits of Client's instructions, if any. The Company's sole responsibility is to its Client and this document does not exonerate parties to a transaction from exercising all their rights and obligations under the transaction documents. This document cannot be reproduced except in full, without prior written approval of the Company. Any unauthorized alteration, forgery or falsification of the content or appearance of this document is unlawful and offenders may be prosecuted to the fullest extent of the law. Unless otherwise stated the results shown in this test report refer only to the sample(s) tested and such sample(s) are retained for 30 days only.

Attention: To check the authenticity of testing /inspection report & certificate, please contact us at telephone: (86-755) 8307 1443, or email: CN.Doccheck@sgs.com

No.1 Workshop, M-10, Middle Section, Science & Technology Park, Nanshan District, Shenzhen, Guangdong, China 518057 t (86-755) 26012053 f (86-755) 26710594 www.sgs.com.cn
 中国·广东·深圳市南山区科技园中区M-10栋1号厂房 邮编:518057 t (86-755) 26012053 f (86-755) 26710594 sgs.china@sgs.com

4.3 Description of Support Units

Description	Manufacturer	Model No.	FCC ID
Router	NETGEAR	R7800	PY315100319

4.4 Measurement Uncertainty

Test Item	Measurement Uncertainty
Conducted Emissions at AC Power Line (150kHz-30MHz)	± 3.1dB
Maximum Conducted output power	± 0.75dB
Radiated Emissions (Below 1GHz)	± 6.0dB for 3m; ± 5.0dB for 10m
Radiated Emissions (Above 1GHz)	± 4.6dB (1-18GHz); ± 4.8dB (18-40GHz)
Radiated Emissions which fall in the restricted bands	± 6.0dB (below 1GHz); ± 4.6dB (above 1GHz);
Duty Cycle	± 0.37%
99% Bandwidth	± 3%
26dB Emission bandwidth	± 3%
Minimum 6 dB bandwidth (5.725-5.85 GHz band)	± 3%
Peak Power spectrum density	± 2.84dB
Frequency Stability	± 7.25 x 10-8

Remark:

The U_{lab} (lab Uncertainty) is less than U_{cispr/ETSI} (CISPR/ETSI Uncertainty), so the test results
 – compliance is deemed to occur if no measured disturbance level exceeds the disturbance limit;
 – non-compliance is deemed to occur if any measured disturbance level exceeds the disturbance limit.



Unless otherwise agreed in writing, this document is issued by the Company subject to its General Conditions of Service printed overleaf, available on request or accessible at <https://www.sgs.com/en/Terms-and-Conditions>. Attention is drawn to the limitation of liability, indemnification and jurisdiction issues defined therein. Any holder of this document is advised that information contained hereon reflects the Company's findings at the time of its intervention only and within the limits of Client's instructions, if any. The Company's sole responsibility is to its Client and this document does not exonerate parties to a transaction from exercising all their rights and obligations under the transaction documents. This document cannot be reproduced except in full, without prior written approval of the Company. Any unauthorized alteration, forgery or falsification of the content or appearance of this document is unlawful and offenders may be prosecuted to the fullest extent of the law. Unless otherwise stated the results shown in this test report refer only to the sample(s) tested and such sample(s) are retained for 30 days only.

4.5 Test Location

All tests were performed at:

SGS-CSTC Standards Technical Services Co., Ltd., Shenzhen Branch

No. 1 Workshop, M-10, Middle Section, Science & Technology Park, Nanshan District, Shenzhen, Guangdong, China. 518057.

Tel: +86 755 2601 2053 Fax: +86 755 2671 0594

No tests were sub-contracted.

4.6 Test Facility

The test facility is recognized, certified, or accredited by the following organizations:

• **A2LA (Certificate No. 3816.01)**

SGS-CSTC Standards Technical Services Co., Ltd., Shenzhen EMC Laboratory is accredited by the American Association for Laboratory Accreditation(A2LA). Certificate No. 3816.01.

• **VCCI (Member No. 1937)**

The 3m Fully-anechoic chamber for above 1GHz, 10m Semi-anechoic chamber for below 1GHz, Shielded Room for Mains Port Conducted Interference Measurement and Telecommunication Port Conducted Interference Measurement of SGS-CSTC Standards Technical Services Co., Ltd. Shenzhen EMC laboratory have been registered in accordance with the Regulations for Voluntary Control Measures with Registration No.: G-20026, R-14188, C-12383 and T-11153 respectively.

• **FCC –Designation Number: CN1336**

SGS-CSTC Standards Technical Services Co., Ltd., Shenzhen EMC Laboratory has been recognized as an accredited testing laboratory.

Designation Number: CN1336. Test Firm Registration Number: 787754.

• **Innovation, Science and Economic Development Canada**

SGS-CSTC Standards Technical Services Co., Ltd., Shenzhen EMC Laboratory has been recognized by ISED as an accredited testing laboratory.

CAB identifier: CN0006.

IC#: 4620C.

4.7 Deviation from Standards

None

4.8 Abnormalities from Standard Conditions

None



5 Equipment List

Conducted Emissions at AC Power Line (150kHz-30MHz)					
Equipment	Manufacturer	Model No.	Inventory No.	Cal Date	Cal Due Date
Shielding Room	ZhongYu Electron	GB-88	SEM001-06	2025-05-07	2028-05-06
EMI Test Receiver	Rohde&Schwarz	ESR	SZ-WRG-M-047	2025-01-08	2026-01-07
Matching Pad	N/A	N/A	SEM021-23	2025-03-19	2026-03-18
Matching Pad	N/A	N/A	SEM021-24	2025-03-19	2026-03-18
Measurement Software	AUDIX	e3 V8.2014-6-27a	N/A	N/A	N/A
Coaxial Cable	SGS	N/A	SEM024-01	2024-07-06	2025-07-05
LISN	Rohde&Schwarz	ENV216	SEM007-01	2024-08-15	2025-08-14
LISN	ETS-LINDGREN	3816/2	SEM007-02	2025-03-03	2026-03-02

Radiated Emissions (Below 1GHz)					
Equipment	Manufacturer	Model No.	Inventory No.	Cal Date	Cal Due Date
Loop Antenna	ETS-Lindgren	6502	SEM003-08	2023-11-20	2025-11-19
3m Semi-Anechoic Chamber	ETS-LINDGREN	N/A	SEM001-01	2023-06-19	2026-06-18
MXE EMI Receiver	Agilent Technologies	N9038A	SEM004-15	2024-08-14	2025-08-13
BiConiLog Antenna	ETS-LINDGREN	3142C	SEM003-01	2023-09-16	2025-09-15
Pre-Amplifier	Agilent Technologies	8447D	SEM005-01	2025-03-04	2026-03-03
Measurement Software	AUDIX	e3 V8.2014-6-27	N/A	N/A	N/A
Coaxial Cable	SGS	N/A	SEM025-01	2024-07-06	2025-07-05



Unless otherwise agreed in writing, this document is issued by the Company subject to its General Conditions of Service printed overleaf, available on request or accessible at <https://www.sgs.com/en/Terms-and-Conditions>. Attention is drawn to the limitation of liability, indemnification and jurisdiction issues defined therein. Any holder of this document is advised that information contained hereon reflects the Company's findings at the time of its intervention only and within the limits of Client's instructions, if any. The Company's sole responsibility is to its Client and this document does not exonerate parties to a transaction from exercising all their rights and obligations under the transaction documents. This document cannot be reproduced except in full, without prior written approval of the Company. Any unauthorized alteration, forgery or falsification of the content or appearance of this document is unlawful and offenders may be prosecuted to the fullest extent of the law. Unless otherwise stated the results shown in this test report refer only to the sample(s) tested and such sample(s) are retained for 30 days only.

Attention: To check the authenticity of testing /inspection report & certificate, please contact us at telephone: (86-755) 8307 1443, or email: CN.Doccheck@sgs.com

SGS-CSTC Standards Technical Services Co., Ltd. Shenzhen Branch

SZEMC-TRF-01 Rev. A/1

Report No.: SZCR250400160706

Page: 12 of 556

Radiated Emissions (Above 1GHz)					
Equipment	Manufacturer	Model No.	Inventory No.	Cal Date	Cal Due Date
Signal & Spectrum Analyzer	Rohde & Schwarz	FSV	SZ-WRG-M-048	2025-01-07	2026-01-06
Low Noise Amplifier 1G-18GHz	Tonscend	TAP01018050	SZ-WRG-M-051	2025-01-07	2026-01-06
Low Noise Amplifier 18G-40GHz	Tonscend	TAP18040048	SZ-WRG-M-052	2025-01-08	2026-01-07
Double Ridge Horn Antenna 1GHz-18GHz	SCHWARZBECK	BBHA 93.83 D	SZ-WRG-M-055	2023-12-21	2025-12-20
SHF-EHF Horn 15GHz-40GHz	SCHWARZBECK	BBHA 9170	SZ-WRG-M-056	2023-12-25	2025-12-24
RSE Test Software	AUDIX	e3 V8.2014-6-27	N/A	N/A	N/A
Chamber	CRTSGSSAC966	N/A	SZ-WRG-C-063	2025-01-06	2028-01-05
Humidity and Temperature Indicator	deli	8838	SEM002-46	2024-07-24	2025-07-23

Radiated Emissions which fall in the restricted bands					
Equipment	Manufacturer	Model No.	Inventory No.	Cal Date	Cal Due Date
Signal & Spectrum Analyzer	Rohde & Schwarz	FSV	SZ-WRG-M-048	2025-01-07	2026-01-06
Low Noise Amplifier 30M-8GHz	Tonscend	TAP30M8G30	SZ-WRG-M-050	2025-01-07	2026-01-06
Double Ridge Horn Antenna 1GHz-18GHz	SCHWARZBECK	BBHA 93.83 D	SZ-WRG-M-055	2023-12-21	2025-12-20
SHF-EHF Horn 15GHz-40GHz	SCHWARZBECK	BBHA 9170	SZ-WRG-M-056	2023-12-25	2025-12-24
RSE Test Software	AUDIX	e3 V8.2014-6-27	N/A	N/A	N/A
Chamber	CRTSGSSAC966	N/A	SZ-WRG-C-063	2025-01-06	2028-01-05
Humidity and Temperature Indicator	deli	8838	SEM002-46	2024-07-24	2025-07-23



Unless otherwise agreed in writing, this document is issued by the Company subject to its General Conditions of Service printed overleaf, available on request or accessible at <https://www.sgs.com/en/Terms-and-Conditions>. Attention is drawn to the limitation of liability, indemnification and jurisdiction issues defined therein. Any holder of this document is advised that information contained hereon reflects the Company's findings at the time of its intervention only and within the limits of Client's instructions, if any. The Company's sole responsibility is to its Client and this document does not exonerate parties to a transaction from exercising all their rights and obligations under the transaction documents. This document cannot be reproduced except in full, without prior written approval of the Company. Any unauthorized alteration, forgery or falsification of the content or appearance of this document is unlawful and offenders may be prosecuted to the fullest extent of the law. Unless otherwise stated the results shown in this test report refer only to the sample(s) tested and such sample(s) are retained for 30 days only.

Attention: To check the authenticity of testing /inspection report & certificate, please contact us at telephone: (86-755) 8307 1443, or email: CN.Doccheck@sgs.com

SGS-CSTC Standards Technical Services Co., Ltd. Shenzhen Branch

SZEMC-TRF-01 Rev. A/1

Report No.: SZCR250400160706

Page: 13 of 556

Channel Move Time					
Equipment	Manufacturer	Model No.	Inventory No.	Cal Date	Cal Due Date
Manual Step Attenuator	KEYSIGHT	8494B	SEM021-05	2025-03-03	2026-03-02
Manual Step Attenuator	KEYSIGHT	8496B	SEM021-06	2025-03-03	2026-03-02
Measurement Software	KEYSIGHT	Signal Studio for DFS Radar Profiles V2.2.0.0	N/A	N/A	N/A
Measurement Software	Agilent	ISMonitor10	N/A	N/A	N/A
MXG Vector Signal Generator	Agilent	N5182A	SEM006-21	2025-03-03	2026-03-02
MXA Signal Analyzer	KEYSIGHT	N9020A	SEM004-22	2025-03-04	2026-03-03

RF Conducted Test					
Equipment	Manufacturer	Model No.	Inventory No.	Cal Date	Cal Due Date
DC Power Supply	Chroma	62012P-80-60	SEM011-11	2024-08-14	2025-08-13
MXA Signal Analyzer	KEYSIGHT	N9020A	SEM004-19	2025-03-04	2026-03-03
Signal Generator	KEYSIGHT	N5173B	SEM006-05	2024-09-14	2025-09-13
Measurement Software	TST PASS	TST PASS V2.0	N/A	N/A	N/A
Coaxial Cable	SGS	N/A	SEM031-01	2024-07-06	2025-07-05
Attenuator	Huber+Suhner	6620_SMA-50-1	SEM021-09	2025-03-03	2026-03-02
Programmable Temperature & Humidity Chamber	Votsch Industrietechnik GmbH	VT 4002	SEM002-15	2025-02-26	2026-02-25
Manual Step Attenuator	KEYSIGHT	8494B	SEM021-05	2025-03-03	2026-03-02
Manual Step Attenuator	KEYSIGHT	8496B	SEM021-06	2025-03-03	2026-03-02
MXG Vector Signal Generator	Agilent	N5182A	SEM006-21	2025-03-03	2026-03-02
MXA Signal Analyzer	KEYSIGHT	N9020A	SEM004-22	2025-03-04	2026-03-03

General used equipment					
Equipment	Manufacturer	Model No.	Inventory No.	Cal Date	Cal Due Date
Humidity/ Temperature Indicator	deli	8838	SEM002-32	2024-07-24	2025-07-23
Humidity/ Temperature Indicator	deli	8838	SEM002-33	2024-07-24	2025-07-23
Barometer	Changchun Meteorological Industry Factory	DYM3	SEM002-01	2025-03-03	2026-03-02



Unless otherwise agreed in writing, this document is issued by the Company subject to its General Conditions of Service printed overleaf, available on request or accessible at <https://www.sgs.com/en/Terms-and-Conditions>. Attention is drawn to the limitation of liability, indemnification and jurisdiction issues defined therein. Any holder of this document is advised that information contained herein reflects the Company's findings at the time of its intervention only and within the limits of Client's instructions, if any. The Company's sole responsibility is to its Client and this document does not exonerate parties to a transaction from exercising all their rights and obligations under the transaction documents. This document cannot be reproduced except in full, without prior written approval of the Company. Any unauthorized alteration, forgery or falsification of the content or appearance of this document is unlawful and offenders may be prosecuted to the fullest extent of the law. Unless otherwise stated the results shown in this test report refer only to the sample(s) tested and such sample(s) are retained for 30 days only.

Attention: To check the authenticity of testing /inspection report & certificate, please contact us at telephone: (86-755) 8307 1443, or email: CN.Doccheck@sgs.com

6 Radio Spectrum Technical Requirement

6.1 Antenna Requirement

6.1.1 Test Requirement:

47 CFR Part 15, Subpart C 15.203

6.1.2 Conclusion

15.203 requirement:

An intentional radiator shall be designed to ensure that no antenna other than that furnished by the responsible party shall be used with the device. The use of a permanently attached antenna or of an antenna that uses a unique coupling to the intentional radiator, the manufacturer may design the unit so that a broken antenna can be replaced by the user, but the use of a standard antenna jack or electrical connector is prohibited.

EUT Antenna:

The antenna is a Fixed Internal Antenna, and the connection port is integrated inside the product, and the antenna cannot be replaced.

5150MHz to 5250MHz: 0.3dBi(Ant9); -0.1dBi(Ant10);*
5250MHz to 5350MHz: 0.1dBi(Ant9); 0.8dBi(Ant10);*
5470MHz to 5725MHz: -1.3dBi(Ant9); 1.6dBi(Ant10);*
5725MHz to 5850MHz: -2.5dBi(Ant9); 0.8dBi(Ant10);*

*Note:

The antenna gain are derived from the gain information report provided by the manufacturer.

Remark:

As above information is provided and confirmed by the applicant. SGS is not liable to the accuracy, suitability, reliability or/and integrity of the information.



Cyclic Delay Diversity (CDD) System:

FCC KDB 662911 D01 Multiple Transmitter Output v02r01

If all antennas have the same gain, G_{ANT} , Directional gain = G_{ANT} + Array Gain, where Array Gain is as follows.

- For power spectral density (PSD) measurements on all devices,
 $Array\ Gain = 10 \log(N_{ANT}/N_{SS}=1) \text{ dB}$.
- For power measurements on IEEE 802.11 devices:
 $Array\ Gain = 0 \text{ dB}$ (i.e., no array gain) for $N_{ANT} \leq 4$;

For power, the directional gain may be calculated by using the formulas applicable to equal gain antennas with G_{ANT} set equal to the gain of the antenna having the highest gain.

For PSD, the directional gain calculation is following F)2)f)ii) of KDB 662911 D01 v02r01.

The Power and PSD limit should be modified if the directional gain of eut is over 6dbi.

The EUT supports CDD System.

All antennas have Unequal antenna gain:

Operation Frequency	ANT Gain0 (dBi)	ANT Gain1 (dBi)	Directional gain For Power (dBi)	Directional gain For PSD (dBi)	Power Limit Reduction (dBm)	PSD Limit Reduction (dBm)
5150MHz to 5250MHz	0.3	-0.1	0.3	3.11	0	0
5250MHz to 5350MHz	0.1	0.8	0.8	3.47	0	0
5470MHz to 5725MHz	-1.3	1.6	1.6	3.28	0	0
5725MHz to 5850MHz	-2.5	0.8	0.8	2.32	0	0

5150MHz to 5250MHz:

Power Limit Reduction = Directional gain – 6dBi, (Directional gain < 6dBi) =0

PSD Limit Reduction = Directional gain – 6dBi, (Directional gain < 6dBi) =0

5250MHz to 5350MHz:

Power Limit Reduction = Directional gain – 6dBi, (Directional gain < 6dBi) =0

PSD Limit Reduction = Directional gain – 6dBi, (Directional gain < 6dBi) =0

5470MHz to 5725MHz:

Power Limit Reduction = Directional gain – 6dBi, (Directional gain < 6dBi) =0

PSD Limit Reduction = Directional gain – 6dBi, (Directional gain < 6dBi) =0

5725MHz to 5850MHz:

Power Limit Reduction = Directional gain – 6dBi, (Directional gain < 6dBi) =0

PSD Limit Reduction = Directional gain – 6dBi, (Directional gain < 6dBi) =0



Unless otherwise agreed in writing, this document is issued by the Company subject to its General Conditions of Service printed overleaf, available on request or accessible at <https://www.sgs.com/en/Terms-and-Conditions>. Attention is drawn to the limitation of liability, indemnification and jurisdiction issues defined therein. Any holder of this document is advised that information contained hereon reflects the Company's findings at the time of its intervention only and within the limits of Client's instructions, if any. The Company's sole responsibility is to its Client and this document does not exonerate parties to a transaction from exercising all their rights and obligations under the transaction documents. This document cannot be reproduced except in full, without prior written approval of the Company. Any unauthorized alteration, forgery or falsification of the content or appearance of this document is unlawful and offenders may be prosecuted to the fullest extent of the law. Unless otherwise stated the results shown in this test report refer only to the sample(s) tested and such sample(s) are retained for 30 days only.

Attention: To check the authenticity of testing /inspection report & certificate, please contact us at telephone: (86-755) 8307 1443, or email: CN.Doccheck@sgs.com

6.2 Transmission in the Absence of Data

6.2.1 Test Requirement:

47 CFR Part 15, Subpart E 15.407 (c)

6.2.2 Conclusion

Standard Requirement:

The device shall automatically discontinue transmission in case of either absence of information to transmit or operational failure. These provisions are not intended to preclude the transmission of control or signalling information or the use of repetitive codes used by certain digital technologies to complete frame or burst intervals.

Applicants shall include in their application for equipment authorization a description of how this requirement is met.

EUT Details:

WIFI chip support automatically discontinue transmission in case of either absence of information to transmit or operational failure, if the chip detect absence of information to transmit or operational failure, it will be automatically shut off.



7 Radio Spectrum Matter Test Results

7.1 Conducted Emissions at AC Power Line (150kHz-30MHz)

Test Requirement 47 CFR Part 15, Subpart C 15.207 & Subpart E 15.407 b(9)

Test Method: ANSI C63.10 (2013) Section 6.2

Limit:

Frequency of emission(MHz)	Conducted limit(dB μ V)	
	Quasi-peak	Average
0.15-0.5	66 to 56*	56 to 46*
0.5-5	56	46
5-30	60	50

*Decreases with the logarithm of the frequency.

7.1.1 E.U.T. Operation

Operating Environment:

Temperature: 22.5 °C Humidity: 44.5 % RH Atmospheric Pressure: 1020 mbar

7.1.2 Test Mode Description

Pre-scan / Final test	Mode Code	Description
Final test	14	Charge + TX mode (U-NII-1) _Keep the EUT in continuously transmitting mode with all modulation types and being charged. All data rates for each modulation type have been tested, Only the data of worst case is recorded in the report.
Pre-scan	15	Charge + TX mode (U-NII-2A) _Keep the EUT in continuously transmitting mode with all modulation types and being charged. All data rates for each modulation type have been tested, Only the data of worst case is recorded in the report.
Pre-scan	16	Charge + TX mode (U-NII-2C) _Keep the EUT in continuously transmitting mode with all modulation types and being charged. All data rates for each modulation type have been tested, Only the data of worst case is recorded in the report.
Pre-scan	17	Charge + TX mode (U-NII-3) _Keep the EUT in continuously transmitting mode with all modulation types and being charged. All data rates for each modulation type have been tested, Only the data of worst case is recorded in the report.



Unless otherwise agreed in writing, this document is issued by the Company subject to its General Conditions of Service printed overleaf, available on request or accessible at <https://www.sgs.com/en/Terms-and-Conditions>. Attention is drawn to the limitation of liability, indemnification and jurisdiction issues defined therein. Any holder of this document is advised that information contained hereon reflects the Company's findings at the time of its intervention only and within the limits of Client's instructions, if any. The Company's sole responsibility is to its Client and this document does not exonerate parties to a transaction from exercising all their rights and obligations under the transaction documents. This document cannot be reproduced except in full, without prior written approval of the Company. Any unauthorized alteration, forgery or falsification of the content or appearance of this document is unlawful and offenders may be prosecuted to the fullest extent of the law. Unless otherwise stated the results shown in this test report refer only to the sample(s) tested and such sample(s) are retained for 30 days only.

Attention: To check the authenticity of testing /inspection report & certificate, please contact us at telephone: (86-755) 8307 1443, or email: CN.Doccheck@sgs.com

7.1.3 Test Setup Diagram

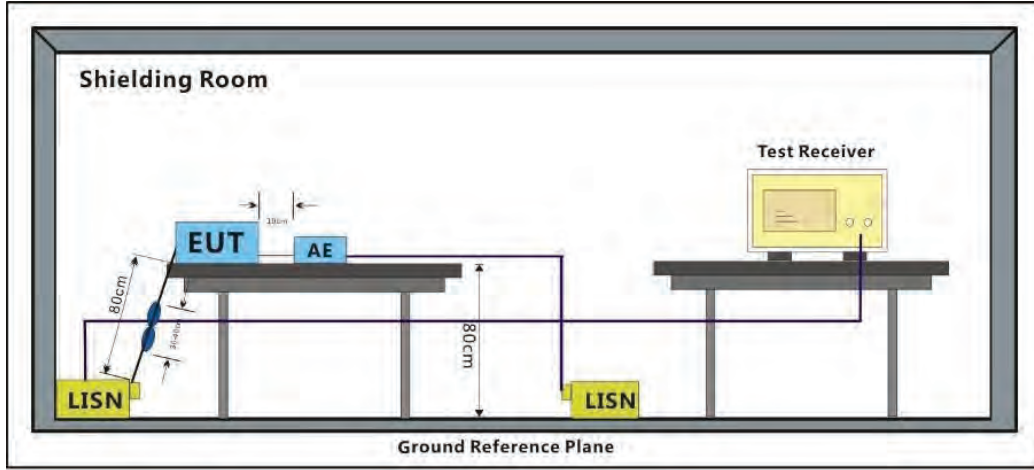

7.1.4 Measurement Procedure and Data

- 1) The mains terminal disturbance voltage test was conducted in a shielded room.
- 2) The EUT was connected to AC power source through a LISN 1 (Line Impedance Stabilization Network) which provides a 50ohm/50μH + 5ohm linear impedance. The power cables of all other units of the EUT were connected to a second LISN 2, which was bonded to the ground reference plane in the same way as the LISN 1 for the unit being measured. A multiple socket outlet strip was used to connect multiple power cables to a single LISN provided the rating of the LISN was not exceeded.
- 3) The tabletop EUT was placed upon a non-metallic table 0.8m above the ground reference plane. And for floor-standing arrangement, the EUT was placed on the horizontal ground reference plane,
- 4) The test was performed with a vertical ground reference plane. The rear of the EUT shall be 0.4 m from the vertical ground reference plane. The vertical ground reference plane was bonded to the horizontal ground reference plane. The LISN 1 was placed 0.8 m from the boundary of the unit under test and bonded to a ground reference plane for LISNs mounted on top of the ground reference plane. This distance was between the closest points of the LISN 1 and the EUT. All other units of the EUT and associated equipment was at least 0.8 m from the LISN 2.
- 5) In order to find the maximum emission, the relative positions of equipment and all of the interface cables must be changed according to ANSI C63.10 on conducted measurement.

Remark 1: Level=Read Level+ Cable Loss+ LISN Factor

Remark 2: Pre-test AC 120V/50-60Hz&AC 240V/50-60Hz then choose the AC 120/60Hz as worst case.



Unless otherwise agreed in writing, this document is issued by the Company subject to its General Conditions of Service printed overleaf, available on request or accessible at <https://www.sgs.com/en/Terms-and-Conditions>. Attention is drawn to the limitation of liability, indemnification and jurisdiction issues defined therein. Any holder of this document is advised that information contained hereon reflects the Company's findings at the time of its intervention only and within the limits of Client's instructions, if any. The Company's sole responsibility is to its Client and this document does not exonerate parties to a transaction from exercising all their rights and obligations under the transaction documents. This document cannot be reproduced except in full, without prior written approval of the Company. Any unauthorized alteration, forgery or falsification of the content or appearance of this document is unlawful and offenders may be prosecuted to the fullest extent of the law. Unless otherwise stated the results shown in this test report refer only to the sample(s) tested and such sample(s) are retained for 30 days only.

Attention: To check the authenticity of testing /inspection report & certificate, please contact us at telephone: (86-755) 8307 1443, or email: CN.Doccheck@sgs.com

Test Mode: 14; Line: Live line

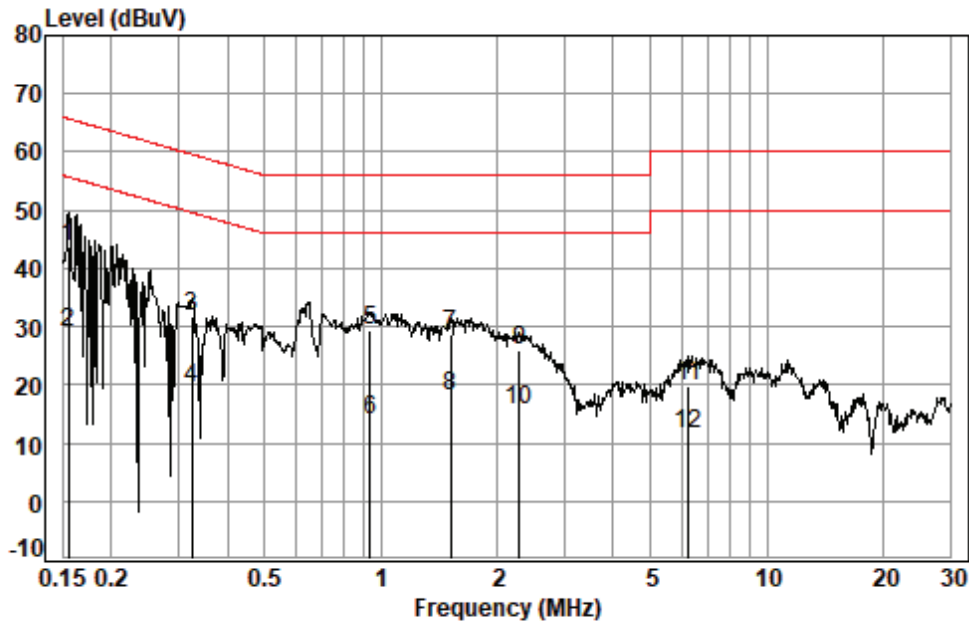

Site : Shielding Room
 Condition: Line
 Job No. : 01607WM
 Test mode: 14

	Freq	Cable Loss	LISN Factor	Read Level	Limit Level	Limit Line	Over Limit	Remark
	MHz	dB	dB	dBuV	dBuV	dBuV	dB	
1 *	0.1548	0.06	10.19	33.60	43.85	65.74	-21.89	QP
2 *	0.1548	0.06	10.19	18.68	28.93	55.74	-26.81	Average
3	0.3234	0.07	9.80	21.91	31.78	59.62	-27.84	QP
4	0.3234	0.07	9.80	9.40	19.27	49.62	-30.35	Average
5	0.9381	0.09	9.59	19.71	29.39	56.00	-26.61	QP
6	0.9381	0.09	9.59	4.44	14.12	46.00	-31.88	Average
7	1.5193	0.10	9.58	18.85	28.53	56.00	-27.47	QP
8	1.5193	0.10	9.58	8.28	17.96	46.00	-28.04	Average
9	2.2847	0.11	9.60	16.14	25.85	56.00	-30.15	QP
10	2.2847	0.11	9.60	6.00	15.71	46.00	-30.29	Average
11	6.2520	0.15	9.67	10.12	19.94	60.00	-40.06	QP
12	6.2520	0.15	9.67	1.62	11.44	50.00	-38.56	Average



Unless otherwise agreed in writing, this document is issued by the Company subject to its General Conditions of Service printed overleaf, available on request or accessible at <https://www.sgs.com/en/Terms-and-Conditions>. Attention is drawn to the limitation of liability, indemnification and jurisdiction issues defined therein. Any holder of this document is advised that information contained hereon reflects the Company's findings at the time of its intervention only and within the limits of Client's instructions, if any. The Company's sole responsibility is to its Client and this document does not exonerate parties to a transaction from exercising all their rights and obligations under the transaction documents. This document cannot be reproduced except in full, without prior written approval of the Company. Any unauthorized alteration, forgery or falsification of the content or appearance of this document is unlawful and offenders may be prosecuted to the fullest extent of the law. Unless otherwise stated the results shown in this test report refer only to the sample(s) tested and such sample(s) are retained for 30 days only.

Attention: To check the authenticity of testing /inspection report & certificate, please contact us at telephone: (86-755) 8307 1443, or email: CN.Doccheck@sgs.com
 No.1 Workshop, M-10, Middle Section, Science & Technology Park, Nanshan District, Shenzhen, Guangdong, China 518057 t (86-755) 26012053 f (86-755) 26710594 www.sgs.com.cn
 中国·广东·深圳市南山区科技园中区M-10栋1号厂房 邮编: 518057 t (86-755) 26012053 f (86-755) 26710594 sgs.china@sgs.com

Test Mode: 14; Line: Neutral Line

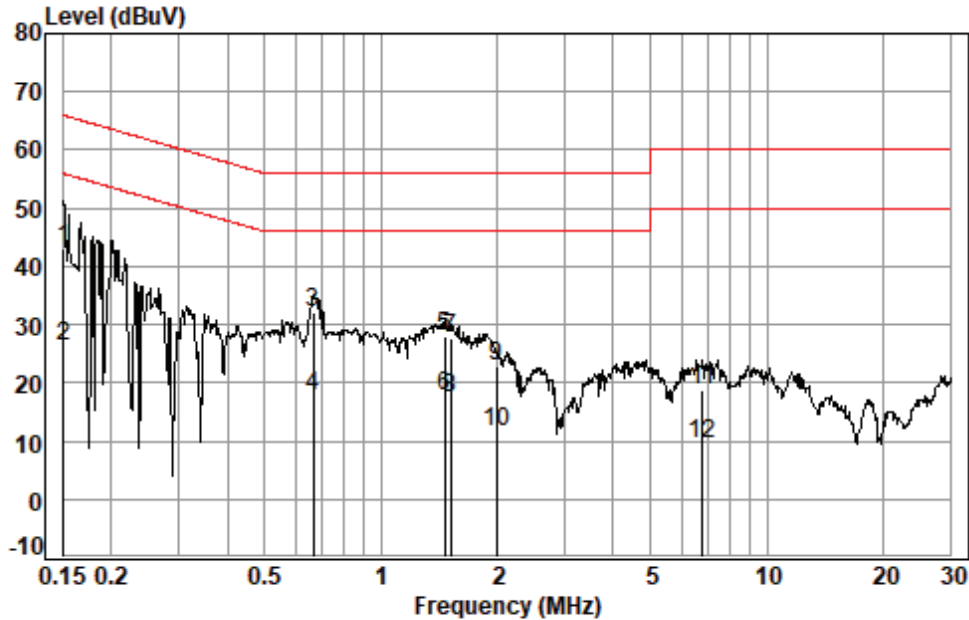

Site : Shielding Room
 Condition: Neutral
 Job No. : 01607WM
 Test mode: 14

	Freq	Cable Loss	LISN Factor	Read Level	Limit Level	Limit Line	Over Limit	Remark
	MHz	dB	dB	dBuV	dBuV	dBuV	dB	
1 *	0.1508	0.06	10.15	32.84	43.05	65.96	-22.91	QP
2	0.1508	0.06	10.15	15.91	26.12	55.96	-29.84	Average
3	0.6683	0.08	9.66	22.40	32.14	56.00	-23.86	QP
4 *	0.6683	0.08	9.66	8.04	17.78	46.00	-28.22	Average
5	1.4640	0.10	9.55	18.40	28.05	56.00	-27.95	QP
6	1.4640	0.10	9.55	8.01	17.66	46.00	-28.34	Average
7	1.5193	0.10	9.55	18.09	27.74	56.00	-28.26	QP
8	1.5193	0.10	9.55	7.56	17.21	46.00	-28.79	Average
9	1.9906	0.10	9.55	13.19	22.84	56.00	-33.16	QP
10	1.9906	0.10	9.55	2.01	11.66	46.00	-34.34	Average
11	6.8051	0.16	9.64	8.98	18.78	60.00	-41.22	QP
12	6.8051	0.16	9.64	-0.23	9.57	50.00	-40.43	Average



Unless otherwise agreed in writing, this document is issued by the Company subject to its General Conditions of Service printed overleaf, available on request or accessible at <https://www.sgs.com/en/Terms-and-Conditions>. Attention is drawn to the limitation of liability, indemnification and jurisdiction issues defined therein. Any holder of this document is advised that information contained hereon reflects the Company's findings at the time of its intervention only and within the limits of Client's instructions, if any. The Company's sole responsibility is to its Client and this document does not exonerate parties to a transaction from exercising all their rights and obligations under the transaction documents. This document cannot be reproduced except in full, without prior written approval of the Company. Any unauthorized alteration, forgery or falsification of the content or appearance of this document is unlawful and offenders may be prosecuted to the fullest extent of the law. Unless otherwise stated the results shown in this test report refer only to the sample(s) tested and such sample(s) are retained for 30 days only.

Attention: To check the authenticity of testing /inspection report & certificate, please contact us at telephone: (86-755) 8307 1443, or email: CN.Doccheck@sgs.com
 No.1 Workshop, M-10, Middle Section, Science & Technology Park, Nanshan District, Shenzhen, Guangdong, China 518057 t (86-755) 26012053 f (86-755) 26710594 www.sgs.com.cn
 中国·广东·深圳市南山区科技园中区M-10栋1号厂房 邮编: 518057 t (86-755) 26012053 f (86-755) 26710594 sgs.china@sgs.com

7.2 Maximum Conducted output power

Test Requirement 47 CFR Part 15, Subpart E 15.407 (a)

Test Method: ANSI C63.10 (2013) Section 12.3

Limit:

Frequency band(MHz)	Limit
5150-5250	≤1W(30dBm) for master device
	≤250mW(24dBm) for client device
5250-5350	≤250mW(24dBm) or 11dBm+10logB*
5470-5725	≤250mW(24dBm) or 11dBm+10logB*
5725-5850	≤1W(30dBm)
Remark:	* Where B is the 26dB emission bandwidth in MHz. The maximum conducted output power must be measured over any interval of continuous transmission using instrumentation calibrated in terms of an rms-equivalent voltage.

7.2.1 E.U.T. Operation

Operating Environment:

Temperature: 25.1 °C Humidity: 40.2 % RH Atmospheric Pressure: 1020 mbar

7.2.2 Test Mode Description

Pre-scan / Final test	Mode Code	Description
Final test	09	TX mode (U-NII-1)_Keep the EUT in continuously transmitting mode with all modulation types. All data rates for each modulation type have been tested, Only the data of worst case is recorded in the report.
Final test	10	TX mode (U-NII-2A) _Keep the EUT in continuously transmitting mode with all modulation types. All data rates for each modulation type have been tested, Only the data of worst case is recorded in the report.
Final test	11	TX mode (U-NII-2C) _Keep the EUT in continuously transmitting mode with all modulation types. All data rates for each modulation type have been tested, Only the data of worst case is recorded in the report.
Final test	12	TX mode (U-NII-3) _Keep the EUT in continuously transmitting mode with all modulation types. All data rates for each modulation type have been tested, Only the data of worst case is recorded in the report.



7.2.3 Test Setup Diagram

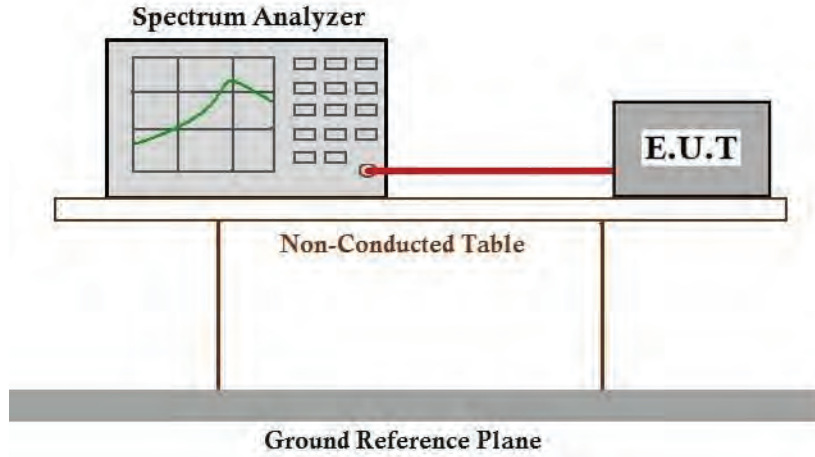

7.2.4 Measurement Procedure and Data

$$AV \text{ Output power Level} = \text{Reading level} + \text{Cable loss} + \text{DCCF}$$

Please Refer to Appendix for Details



Unless otherwise agreed in writing, this document is issued by the Company subject to its General Conditions of Service printed overleaf, available on request or accessible at <https://www.sgs.com/en/Terms-and-Conditions>. Attention is drawn to the limitation of liability, indemnification and jurisdiction issues defined therein. Any holder of this document is advised that information contained hereon reflects the Company's findings at the time of its intervention only and within the limits of Client's instructions, if any. The Company's sole responsibility is to its Client and this document does not exonerate parties to a transaction from exercising all their rights and obligations under the transaction documents. This document cannot be reproduced except in full, without prior written approval of the Company. Any unauthorized alteration, forgery or falsification of the content or appearance of this document is unlawful and offenders may be prosecuted to the fullest extent of the law. Unless otherwise stated the results shown in this test report refer only to the sample(s) tested and such sample(s) are retained for 30 days only.

Attention: To check the authenticity of testing /inspection report & certificate, please contact us at telephone: (86-755) 8307 1443, or email: CN.Doccheck@sgs.com
 No.1 Workshop, M-10, Middle Section, Science & Technology Park, Nanshan District, Shenzhen, Guangdong, China 518057 t (86-755) 26012053 f (86-755) 26710594 www.sgs.com.cn
 中国·广东·深圳市南山区科技园中区M-10栋1号厂房 邮编: 518057 t (86-755) 26012053 f (86-755) 26710594 sgs.china@sgs.com

7.3 Radiated Emissions (Below 1GHz)

Test Requirement 47 CFR Part 15, Subpart C 15.209 & Subpart E 15.407(b)

Test Method: ANSI C63.10 (2013) Section 6.4,6.5

Limit:

Frequency(MHz)	Field strength(microvolts/meter)	Measurement distance(meters)
0.009-0.490	2400/F(kHz)	300
0.490-1.705	24000/F(kHz)	30
1.705-30.0	30	30
30-88	100	3
88-216	150	3
216-960	200	3
960-1000	500	3

7.3.1 E.U.T. Operation

Operating Environment:

Temperature: 23.6 °C Humidity: 42.8 % RH Atmospheric Pressure: 1020 mbar

7.3.2 Test Mode Description

Pre-scan / Final test	Mode Code	Description
Final test	14	Charge + TX mode (U-NII-1) _Keep the EUT in continuously transmitting mode with all modulation types and being charged. All data rates for each modulation type have been tested, Only the data of worst case is recorded in the report.
Final test	15	Charge + TX mode (U-NII-2A) _Keep the EUT in continuously transmitting mode with all modulation types and being charged. All data rates for each modulation type have been tested, Only the data of worst case is recorded in the report.
Final test	16	Charge + TX mode (U-NII-2C) _Keep the EUT in continuously transmitting mode with all modulation types and being charged. All data rates for each modulation type have been tested, Only the data of worst case is recorded in the report.
Final test	17	Charge + TX mode (U-NII-3) _Keep the EUT in continuously transmitting mode with all modulation types and being charged. All data rates for each modulation type have been tested, Only the data of worst case is recorded in the report.



Unless otherwise agreed in writing, this document is issued by the Company subject to its General Conditions of Service printed overleaf, available on request or accessible at <https://www.sgs.com/en/Terms-and-Conditions>. Attention is drawn to the limitation of liability, indemnification and jurisdiction issues defined therein. Any holder of this document is advised that information contained hereon reflects the Company's findings at the time of its intervention only and within the limits of Client's instructions, if any. The Company's sole responsibility is to its Client and this document does not exonerate parties to a transaction from exercising all their rights and obligations under the transaction documents. This document cannot be reproduced except in full, without prior written approval of the Company. Any unauthorized alteration, forgery or falsification of the content or appearance of this document is unlawful and offenders may be prosecuted to the fullest extent of the law. Unless otherwise stated the results shown in this test report refer only to the sample(s) tested and such sample(s) are retained for 30 days only.

Attention: To check the authenticity of testing /inspection report & certificate, please contact us at telephone: (86-755) 8307 1443, or email: CN.Doccheck@sgs.com
 No.1 Workshop, M-10, Middle Section, Science & Technology Park, Nanshan District, Shenzhen, Guangdong, China 518057 t (86-755) 26012053 f (86-755) 26710594 www.sgs.com.cn
 中国·广东·深圳市南山区科技园中区M-10栋1号厂房 邮编: 518057 t (86-755) 26012053 f (86-755) 26710594 sgs.china@sgs.com

7.3.3 Test Setup Diagram

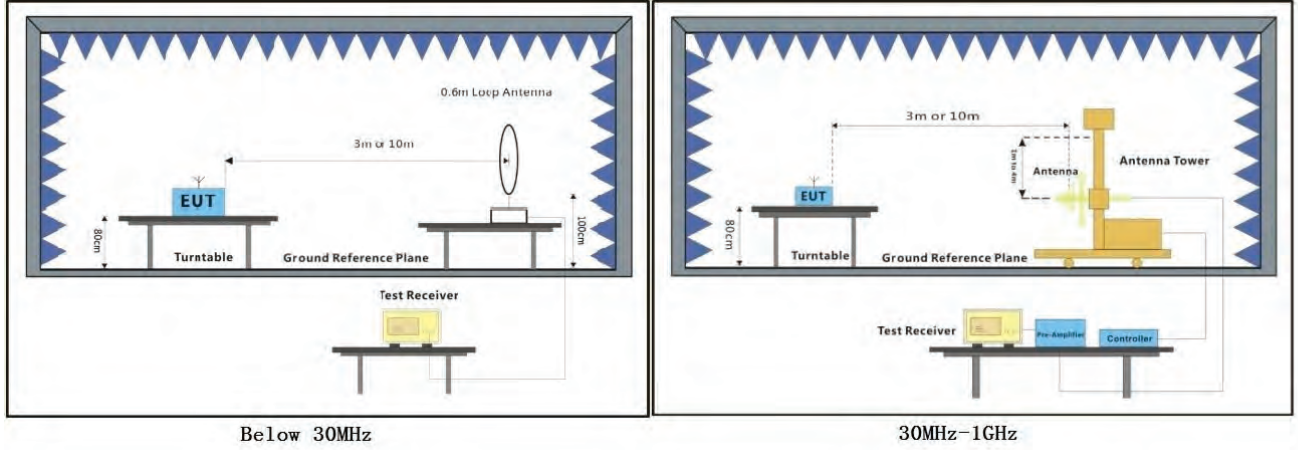

Below 30MHz

30MHz-1GHz



Unless otherwise agreed in writing, this document is issued by the Company subject to its General Conditions of Service printed overleaf, available on request or accessible at <https://www.sgs.com/en/Terms-and-Conditions>. Attention is drawn to the limitation of liability, indemnification and jurisdiction issues defined therein. Any holder of this document is advised that information contained hereon reflects the Company's findings at the time of its intervention only and within the limits of Client's instructions, if any. The Company's sole responsibility is to its Client and this document does not exonerate parties to a transaction from exercising all their rights and obligations under the transaction documents. This document cannot be reproduced except in full, without prior written approval of the Company. Any unauthorized alteration, forgery or falsification of the content or appearance of this document is unlawful and offenders may be prosecuted to the fullest extent of the law. Unless otherwise stated the results shown in this test report refer only to the sample(s) tested and such sample(s) are retained for 30 days only.

Attention: To check the authenticity of testing /inspection report & certificate, please contact us at telephone: (86-755) 8307 1443, or email: CN.Doccheck@sgs.com
 No.1 Workshop, M-10, Middle Section, Science & Technology Park, Nanshan District, Shenzhen, Guangdong, China 518057 t (86-755) 26012053 f (86-755) 26710594 www.sgs.com.cn
 中国·广东·深圳市南山区科技园中区M-10栋1号厂房 邮编: 518057 t (86-755) 26012053 f (86-755) 26710594 sgs.china@sgs.com

7.3.4 Measurement Procedure and Data

- a. For below 1GHz, the EUT was placed on the top of a rotating table 0.8 meters above the ground at a 3 meter semi-anechoic chamber. The table was rotated 360 degrees to determine the position of the highest radiation.
- b. The EUT was set 3 or 10 meters away from the interference-receiving antenna, which was mounted on the top of a variable-height antenna tower.
- c. The antenna height is varied from one meter to four meters above the ground to determine the maximum value of the field strength. Both horizontal and vertical polarizations of the antenna are set to make the measurement.
- d. For each suspected emission, the EUT was arranged to its worst case and then the antenna was tuned to heights from 1 meter to 4 meters (for the test frequency of below 30MHz, the antenna was tuned to heights 1 meter) and the rotatable table was turned from 0 degrees to 360 degrees to find the maximum reading.
- e. The test-receiver system was set to Peak Detect Function and Specified Bandwidth with Maximum Hold Mode.
- f. If the emission level of the EUT in peak mode was 10dB lower than the limit specified, then testing could be stopped and the peak values of the EUT would be reported. Otherwise the emissions that did not have 10dB margin would be re-tested one by one using quasi-peak method as specified and then reported in a data sheet.
- g. Test the EUT in the lowest channel, the middle channel, the Highest channel.
- h. The radiation measurements are performed in X, Y, Z axis positioning for Transmitting mode, and found the X axis positioning which it is the worst case.
- i. Repeat above procedures until all frequencies measured was complete.

Remark:

1. Level= Read Level+ Cable Loss+ Antenna Factor- Preamp Factor
2. For emission below 1GHz, through the pre-scan found the worst case is the lowest channel of 802.11a. Only the worst case is recorded in the report.
3. Scan from 9kHz to 30MHz, the disturbance below 30MHz was very low. The points marked on above plots are the highest emissions could be found when testing, so only above points had been displayed. The amplitude of spurious emissions from the radiator which are attenuated more than 20dB below the limit need not be reported.



Test Mode: 14; Polarity: Horizontal

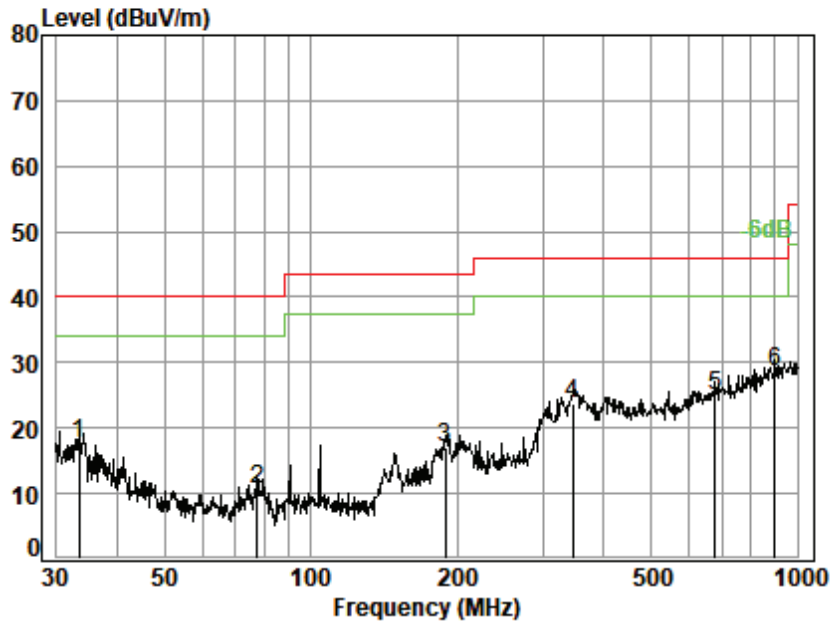

Site : chamber
 Condition: 3m HORIZONTAL
 Job No. : 01607WM
 Test Mode: 14

	Ant Freq	Cable Factor	Preamp Loss	Read Level	Limit Level	Over Line	Remark
	MHz	dB/m	dB	dBuV	dBuV/m	dBuV/m	dB
1	33.328	19.73	0.71	27.78	25.12	40.00	-22.22 QP
2	77.593	10.39	1.07	27.65	26.75	40.00	-29.44 QP
3	189.074	14.29	1.72	27.22	28.13	43.50	-26.58 QP
4	345.595	19.58	2.39	26.94	28.80	46.00	-22.17 QP
5	677.580	25.78	3.48	27.78	23.55	46.00	-20.97 QP
6 q	900.147	27.82	4.12	26.76	23.38	46.00	-17.44 QP



Unless otherwise agreed in writing, this document is issued by the Company subject to its General Conditions of Service printed overleaf, available on request or accessible at <https://www.sgs.com/en/Terms-and-Conditions>. Attention is drawn to the limitation of liability, indemnification and jurisdiction issues defined therein. Any holder of this document is advised that information contained hereon reflects the Company's findings at the time of its intervention only and within the limits of Client's instructions, if any. The Company's sole responsibility is to its Client and this document does not exonerate parties to a transaction from exercising all their rights and obligations under the transaction documents. This document cannot be reproduced except in full, without prior written approval of the Company. Any unauthorized alteration, forgery or falsification of the content or appearance of this document is unlawful and offenders may be prosecuted to the fullest extent of the law. Unless otherwise stated the results shown in this test report refer only to the sample(s) tested and such sample(s) are retained for 30 days only.

Attention: To check the authenticity of testing /inspection report & certificate, please contact us at telephone: (86-755) 8307 1443, or email: CN.Doccheck@sgs.com
 No.1 Workshop, M-10, Middle Section, Science & Technology Park, Nanshan District, Shenzhen, Guangdong, China 518057 t (86-755) 26012053 f (86-755) 26710594 www.sgs.com.cn
 中国·广东·深圳市南山区科技园中区M-10栋1号厂房 邮编: 518057 t (86-755) 26012053 f (86-755) 26710594 sgs.china@sgs.com

Test Mode: 14; Polarity: Vertical

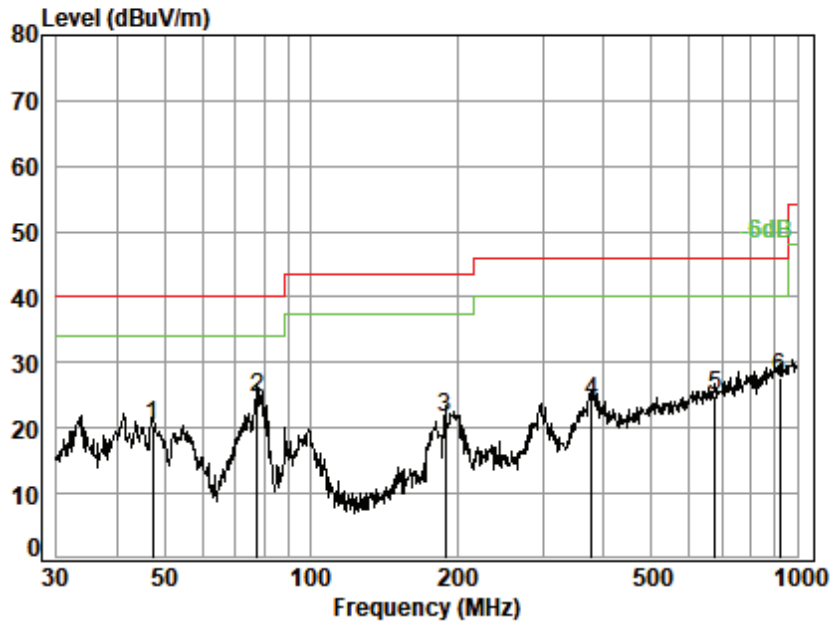

Site : chamber
 Condition: 3m VERTICAL
 Job No. : 01607WM
 Test Mode: 14

	Ant Freq	Cable Factor	Preamp Loss	Read Preamp	Read Level	Limit Level	Over Line	Remark
	MHz	dB/m	dB	dB	dBuV	dBuV/m	dBuV/m	dB
1	47.326	13.53	0.84	27.74	33.72	20.35	40.00	-19.65 QP
2 q	77.593	10.39	1.07	27.65	40.90	24.71	40.00	-15.29 QP
3	189.074	14.29	1.72	27.22	32.74	21.53	43.50	-21.97 QP
4	377.259	20.80	2.50	27.06	27.66	23.90	46.00	-22.10 QP
5	677.580	25.78	3.48	27.78	23.35	24.83	46.00	-21.17 QP
6	919.287	28.17	4.17	26.63	21.97	27.68	46.00	-18.32 QP



Unless otherwise agreed in writing, this document is issued by the Company subject to its General Conditions of Service printed overleaf, available on request or accessible at <https://www.sgs.com/en/Terms-and-Conditions>. Attention is drawn to the limitation of liability, indemnification and jurisdiction issues defined therein. Any holder of this document is advised that information contained hereon reflects the Company's findings at the time of its intervention only and within the limits of Client's instructions, if any. The Company's sole responsibility is to its Client and this document does not exonerate parties to a transaction from exercising all their rights and obligations under the transaction documents. This document cannot be reproduced except in full, without prior written approval of the Company. Any unauthorized alteration, forgery or falsification of the content or appearance of this document is unlawful and offenders may be prosecuted to the fullest extent of the law. Unless otherwise stated the results shown in this test report refer only to the sample(s) tested and such sample(s) are retained for 30 days only.

Attention: To check the authenticity of testing /inspection report & certificate, please contact us at telephone: (86-755) 8307 1443, or email: CN.Doccheck@sgs.com
 No.1 Workshop, M-10, Middle Section, Science & Technology Park, Nanshan District, Shenzhen, Guangdong, China 518057 t (86-755) 26012053 f (86-755) 26710594 www.sgs.com.cn
 中国·广东·深圳市南山区科技园中区M-10栋1号厂房 邮编: 518057 t (86-755) 26012053 f (86-755) 26710594 sgs.china@sgs.com

Test Mode: 15; Polarity: Horizontal

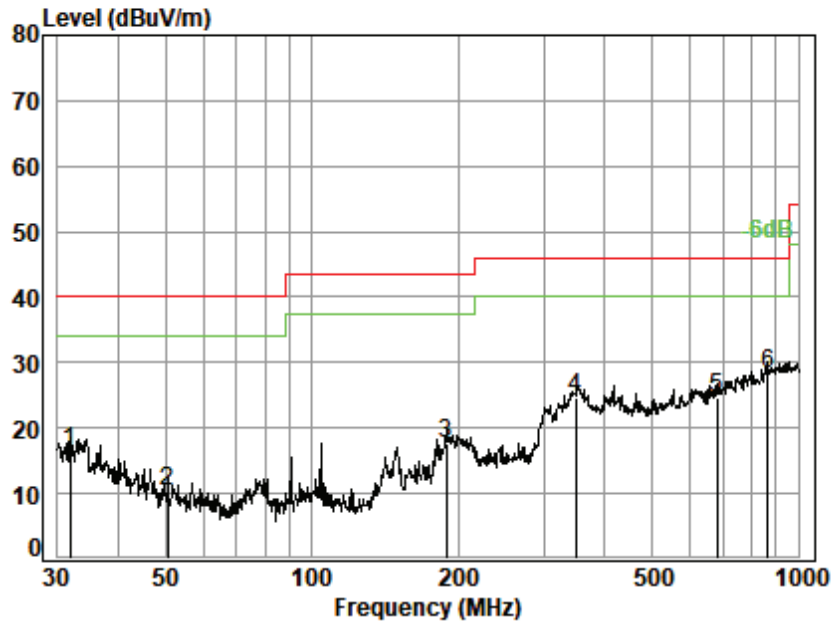

Site : chamber
 Condition: 3m HORIZONTAL
 Job No. : 01607WM
 Test Mode: 15

	Ant Freq	Ant Factor	Cable Loss	Preamp Factor	Read Level	Limit Level	Limit Line	Over Limit	Remark
	MHz	dB/m	dB	dB	dBuV	dBuV/m	dBuV/m	dB	
1	31.843	20.34	0.69	27.79	23.21	16.45	40.00	-23.55	QP
2	50.586	12.67	0.87	27.73	24.57	10.38	40.00	-29.62	QP
3	189.074	14.29	1.72	27.22	28.88	17.67	43.50	-25.83	QP
4	349.250	19.86	2.40	26.95	29.26	24.57	46.00	-21.43	QP
5	679.960	25.86	3.48	27.77	23.21	24.78	46.00	-21.22	QP
6 q	866.088	27.66	4.04	27.01	23.48	28.17	46.00	-17.83	QP



Unless otherwise agreed in writing, this document is issued by the Company subject to its General Conditions of Service printed overleaf, available on request or accessible at <https://www.sgs.com/en/Terms-and-Conditions>. Attention is drawn to the limitation of liability, indemnification and jurisdiction issues defined therein. Any holder of this document is advised that information contained hereon reflects the Company's findings at the time of its intervention only and within the limits of Client's instructions, if any. The Company's sole responsibility is to its Client and this document does not exonerate parties to a transaction from exercising all their rights and obligations under the transaction documents. This document cannot be reproduced except in full, without prior written approval of the Company. Any unauthorized alteration, forgery or falsification of the content or appearance of this document is unlawful and offenders may be prosecuted to the fullest extent of the law. Unless otherwise stated the results shown in this test report refer only to the sample(s) tested and such sample(s) are retained for 30 days only.

Test Mode: 15; Polarity: Vertical

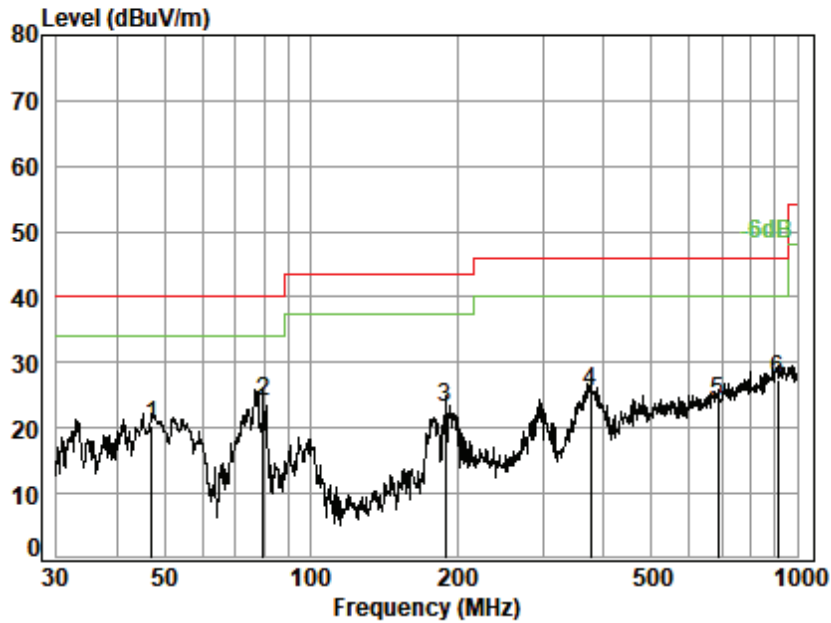

Site : chamber
 Condition: 3m VERTICAL
 Job No. : 01607WM
 Test Mode: 15

	Ant Freq	Cable Factor	Preamp Loss	Read Level	Limit Level	Over Line	Over Limit	Remark
	MHz	dB/m	dB	dBuV	dBuV/m	dBuV/m	dB	
1	47.160	13.59	0.84	27.74	33.58	20.27	40.00	-19.73 QP
2	79.800	10.44	1.09	27.65	40.10	23.98	40.00	-16.02 QP
3	189.074	14.29	1.72	27.22	34.27	23.06	43.50	-20.44 QP
4	375.939	20.74	2.50	27.06	29.49	25.67	46.00	-20.33 QP
5	687.151	25.71	3.50	27.76	22.45	23.90	46.00	-22.10 QP
6	912.862	28.01	4.16	26.67	21.93	27.43	46.00	-18.57 QP



Unless otherwise agreed in writing, this document is issued by the Company subject to its General Conditions of Service printed overleaf, available on request or accessible at <https://www.sgs.com/en/Terms-and-Conditions>. Attention is drawn to the limitation of liability, indemnification and jurisdiction issues defined therein. Any holder of this document is advised that information contained hereon reflects the Company's findings at the time of its intervention only and within the limits of Client's instructions, if any. The Company's sole responsibility is to its Client and this document does not exonerate parties to a transaction from exercising all their rights and obligations under the transaction documents. This document cannot be reproduced except in full, without prior written approval of the Company. Any unauthorized alteration, forgery or falsification of the content or appearance of this document is unlawful and offenders may be prosecuted to the fullest extent of the law. Unless otherwise stated the results shown in this test report refer only to the sample(s) tested and such sample(s) are retained for 30 days only.

Attention: To check the authenticity of testing /inspection report & certificate, please contact us at telephone: (86-755) 8307 1443, or email: CN.Doccheck@sgs.com
 No.1 Workshop, M-10, Middle Section, Science & Technology Park, Nanshan District, Shenzhen, Guangdong, China 518057 t (86-755) 26012053 f (86-755) 26710594 www.sgs.com.cn
 中国·广东·深圳市南山区科技园中区M-10栋1号厂房 邮编: 518057 t (86-755) 26012053 f (86-755) 26710594 sgs.china@sgs.com

Test Mode: 16; Polarity: Horizontal

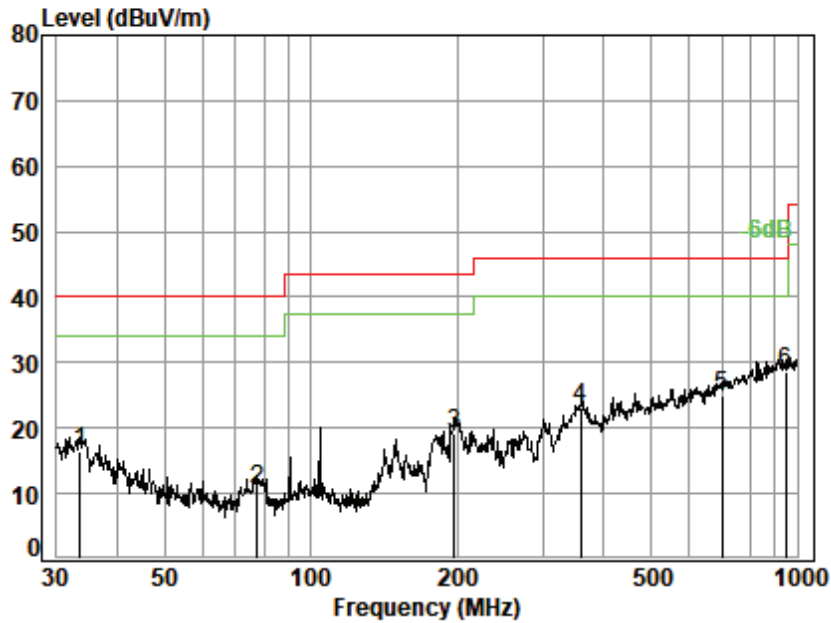

Site : chamber
 Condition: 3m HORIZONTAL
 Job No. : 01607WM
 Test Mode: 16

	Ant Freq	Cable Factor	Preamp Loss	Read Level	Limit Level	Over Line	Remark
	MHz	dB/m	dB	dBuV	dBuV/m	dBuV/m	dB
1	33.562	19.63	0.71	27.78	23.95	40.00	-23.49 QP
2	77.593	10.39	1.07	27.65	26.96	40.00	-29.23 QP
3	197.200	14.10	1.75	27.18	30.57	43.50	-24.26 QP
4	359.186	20.20	2.44	26.99	27.57	46.00	-22.78 QP
5	699.305	25.93	3.54	27.73	23.18	46.00	-21.08 QP
6 q	948.761	28.23	4.25	26.42	22.46	46.00	-17.48 QP



Unless otherwise agreed in writing, this document is issued by the Company subject to its General Conditions of Service printed overleaf, available on request or accessible at <https://www.sgs.com/en/Terms-and-Conditions>. Attention is drawn to the limitation of liability, indemnification and jurisdiction issues defined therein. Any holder of this document is advised that information contained hereon reflects the Company's findings at the time of its intervention only and within the limits of Client's instructions, if any. The Company's sole responsibility is to its Client and this document does not exonerate parties to a transaction from exercising all their rights and obligations under the transaction documents. This document cannot be reproduced except in full, without prior written approval of the Company. Any unauthorized alteration, forgery or falsification of the content or appearance of this document is unlawful and offenders may be prosecuted to the fullest extent of the law. Unless otherwise stated the results shown in this test report refer only to the sample(s) tested and such sample(s) are retained for 30 days only.

Test Mode: 16; Polarity: Vertical

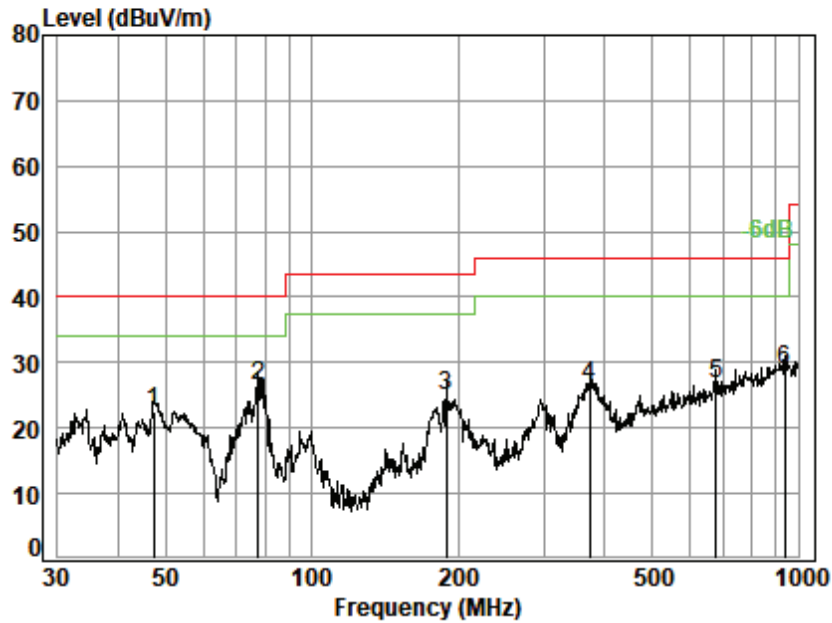

Site : chamber
 Condition: 3m VERTICAL
 Job No. : 01607WM
 Test Mode: 16

	Ant Freq	Cable Factor	Preamp Loss	Read Level	Limit Level	Over Line	Limit	Over Limit	Remark
	MHz	dB/m	dB	dB	dBuV	dBuV/m	dBuV/m	dB	
1	47.326	13.53	0.84	27.74	35.90	22.53	40.00	-17.47	QP
2	77.593	10.39	1.07	27.65	42.65	26.46	40.00	-13.54	QP
3	189.074	14.29	1.72	27.22	36.25	25.04	43.50	-18.46	QP
4	373.311	20.61	2.49	27.05	30.29	26.34	46.00	-19.66	QP
5	677.580	25.78	3.48	27.78	25.28	26.76	46.00	-19.24	QP
6	938.833	28.15	4.22	26.49	23.01	28.89	46.00	-17.11	QP



Unless otherwise agreed in writing, this document is issued by the Company subject to its General Conditions of Service printed overleaf, available on request or accessible at <https://www.sgs.com/en/Terms-and-Conditions>. Attention is drawn to the limitation of liability, indemnification and jurisdiction issues defined therein. Any holder of this document is advised that information contained hereon reflects the Company's findings at the time of its intervention only and within the limits of Client's instructions, if any. The Company's sole responsibility is to its Client and this document does not exonerate parties to a transaction from exercising all their rights and obligations under the transaction documents. This document cannot be reproduced except in full, without prior written approval of the Company. Any unauthorized alteration, forgery or falsification of the content or appearance of this document is unlawful and offenders may be prosecuted to the fullest extent of the law. Unless otherwise stated the results shown in this test report refer only to the sample(s) tested and such sample(s) are retained for 30 days only.

Attention: To check the authenticity of testing /inspection report & certificate, please contact us at telephone: (86-755) 8307 1443, or email: CN.Doccheck@sgs.com
 No.1 Workshop, M-10, Middle Section, Science & Technology Park, Nanshan District, Shenzhen, Guangdong, China 518057 t (86-755) 26012053 f (86-755) 26710594 www.sgs.com.cn
 中国·广东·深圳市南山区科技园中区M-10栋1号厂房 邮编: 518057 t (86-755) 26012053 f (86-755) 26710594 sgs.china@sgs.com

Test Mode: 17; Polarity: Horizontal

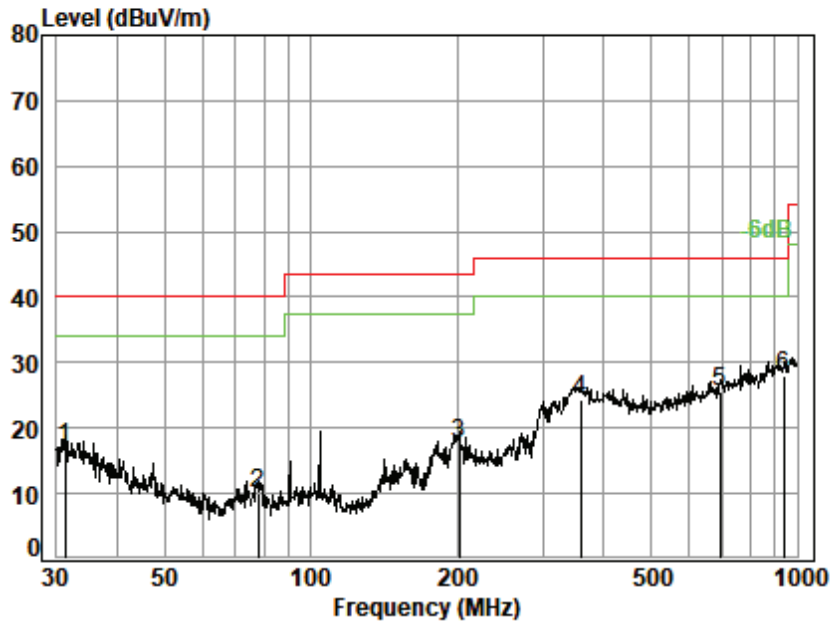

Site : chamber
 Condition: 3m HORIZONTAL
 Job No. : 01607WM
 Test Mode: 17

	Ant Freq	Cable Factor	Preamp Loss	Read Level	Limit Level	Over Line	Remark
	MHz	dB/m	dB	dBuV	dBuV/m	dBuV/m	dB
1	31.180	20.65	0.68	27.79	23.35	16.89	40.00 -23.11 QP
2	77.865	10.39	1.08	27.65	26.14	9.96	40.00 -30.04 QP
3	201.393	14.22	1.77	27.16	28.72	17.55	43.50 -25.95 QP
4	357.929	20.16	2.43	26.99	28.67	24.27	46.00 -21.73 QP
5	694.417	25.82	3.52	27.74	23.91	25.51	46.00 -20.49 QP
6 q	938.833	28.15	4.22	26.49	22.18	28.06	46.00 -17.94 QP



Unless otherwise agreed in writing, this document is issued by the Company subject to its General Conditions of Service printed overleaf, available on request or accessible at <https://www.sgs.com/en/Terms-and-Conditions>. Attention is drawn to the limitation of liability, indemnification and jurisdiction issues defined therein. Any holder of this document is advised that information contained hereon reflects the Company's findings at the time of its intervention only and within the limits of Client's instructions, if any. The Company's sole responsibility is to its Client and this document does not exonerate parties to a transaction from exercising all their rights and obligations under the transaction documents. This document cannot be reproduced except in full, without prior written approval of the Company. Any unauthorized alteration, forgery or falsification of the content or appearance of this document is unlawful and offenders may be prosecuted to the fullest extent of the law. Unless otherwise stated the results shown in this test report refer only to the sample(s) tested and such sample(s) are retained for 30 days only.

Attention: To check the authenticity of testing /inspection report & certificate, please contact us at telephone: (86-755) 8307 1443, or email: CN.Doccheck@sgs.com
 No.1 Workshop, M-10, Middle Section, Science & Technology Park, Nanshan District, Shenzhen, Guangdong, China 518057 t (86-755) 26012053 f (86-755) 26710594 www.sgs.com.cn
 中国·广东·深圳市南山区科技园中区M-10栋1号厂房 邮编: 518057 t (86-755) 26012053 f (86-755) 26710594 sgs.china@sgs.com

Test Mode: 17; Polarity: Vertical

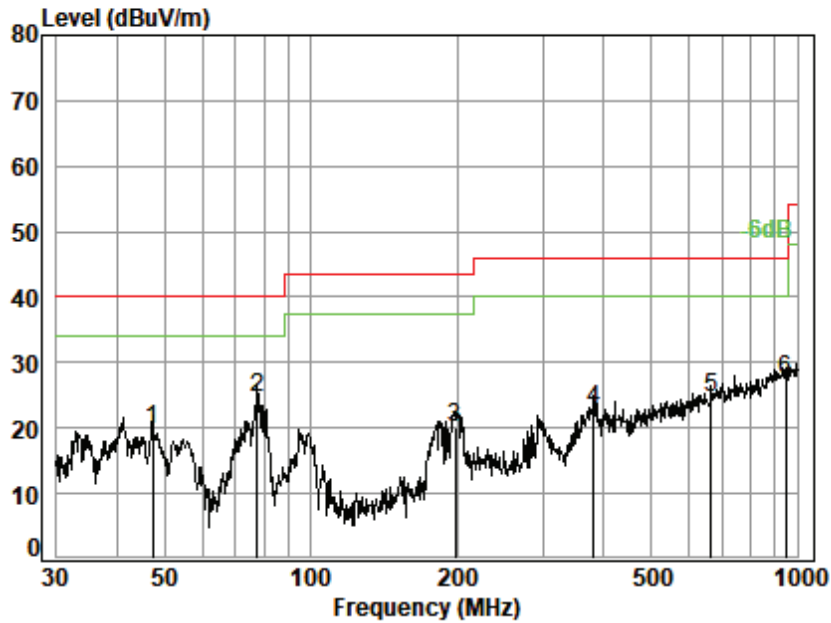

Site : chamber
 Condition: 3m VERTICAL
 Job No. : 01607WM
 Test Mode: 17

	Ant Freq	Ant Factor	Cable Loss	Preamp Factor	Read Level	Limit Level	Limit Line	Over Limit	Remark
	MHz	dB/m	dB	dB	dBuV	dBuV/m	dBuV/m	dB	
1	47.326	13.53	0.84	27.74	33.22	19.85	40.00	-20.15	QP
2	77.593	10.39	1.07	27.65	40.69	24.50	40.00	-15.50	QP
3	197.893	14.08	1.75	27.18	31.51	20.16	43.50	-23.34	QP
4	381.249	20.91	2.52	27.08	26.49	22.84	46.00	-23.16	QP
5	663.473	25.32	3.44	27.81	23.61	24.56	46.00	-21.44	QP
6	945.440	28.26	4.24	26.44	21.26	27.32	46.00	-18.68	QP



Unless otherwise agreed in writing, this document is issued by the Company subject to its General Conditions of Service printed overleaf, available on request or accessible at <https://www.sgs.com/en/Terms-and-Conditions>. Attention is drawn to the limitation of liability, indemnification and jurisdiction issues defined therein. Any holder of this document is advised that information contained hereon reflects the Company's findings at the time of its intervention only and within the limits of Client's instructions, if any. The Company's sole responsibility is to its Client and this document does not exonerate parties to a transaction from exercising all their rights and obligations under the transaction documents. This document cannot be reproduced except in full, without prior written approval of the Company. Any unauthorized alteration, forgery or falsification of the content or appearance of this document is unlawful and offenders may be prosecuted to the fullest extent of the law. Unless otherwise stated the results shown in this test report refer only to the sample(s) tested and such sample(s) are retained for 30 days only.

Attention: To check the authenticity of testing /inspection report & certificate, please contact us at telephone: (86-755) 8307 1443, or email: CN.Doccheck@sgs.com
 No.1 Workshop, M-10, Middle Section, Science & Technology Park, Nanshan District, Shenzhen, Guangdong, China 518057 t (86-755) 26012053 f (86-755) 26710594 www.sgs.com.cn
 中国·广东·深圳市南山区科技园中区M-10栋1号厂房 邮编: 518057 t (86-755) 26012053 f (86-755) 26710594 sgs.china@sgs.com

7.4 Radiated Emissions (Above 1GHz)

Test Requirement 47 CFR Part 15, Subpart C 15.209 & Subpart E 15.407(b)

Test Method: ANSI C63.10 (2013) Section 6.6

Measurement Distance: 3m

Limit:

Frequency(MHz)	Field strength(microvolts/meter)	Measurement distance(meters)
0.009-0.490	2400/F(kHz)	300
0.490-1.705	24000/F(kHz)	30
1.705-30.0	30	30
30-88	100	3
88-216	150	3
216-960	200	3
Above 960	500	3

*(1) For transmitters operating in the 5.15-5.25 GHz band: All emissions outside of the 5.15-5.35 GHz band shall not exceed an e.i.r.p. of -27 dBm/MHz.

(2) For transmitters operating in the 5.25-5.35 GHz band: All emissions outside of the 5.15-5.35 GHz band shall not exceed an e.i.r.p. of -27 dBm/MHz.

(3) For transmitters operating in the 5.47-5.725 GHz band: All emissions outside of the 5.47-5.725 GHz band shall not exceed an e.i.r.p. of -27 dBm/MHz.

(4) For transmitters operating in the 5.725-5.85 GHz band:

(i) All emissions shall be limited to a level of -27 dBm/MHz at 75 MHz or more above or below the band edge increasing linearly to 10 dBm/MHz at 25 MHz above or below the band edge, and from 25 MHz above or below the band edge increasing linearly to a level of 15.6 dBm/MHz at 5 MHz above or below the band edge, and from 5 MHz above or below the band edge increasing linearly to a level of 27 dBm/MHz at the band edge.

Remark: The emission limits shown in the above table are based on measurements employing a CISPR quasi-peak detector except for the frequency bands 9-90kHz, 110-490kHz and above 1000 MHz. Radiated emission limits in these three bands are based on measurements employing an average detector, the peak field strength of any emission shall not exceed the maximum permitted average limits specified above by more than 20 dB under any condition of modulation.

7.4.1 E.U.T. Operation

Operating Environment:

Temperature: 24.5 °C Humidity: 50.8 % RH Atmospheric Pressure: 1020 mbar



Unless otherwise agreed in writing, this document is issued by the Company subject to its General Conditions of Service printed overleaf, available on request or accessible at <https://www.sgs.com/en/Terms-and-Conditions>. Attention is drawn to the limitation of liability, indemnification and jurisdiction issues defined therein. Any holder of this document is advised that information contained hereon reflects the Company's findings at the time of its intervention only and within the limits of Client's instructions, if any. The Company's sole responsibility is to its Client and this document does not exonerate parties to a transaction from exercising all their rights and obligations under the transaction documents. This document cannot be reproduced except in full, without prior written approval of the Company. Any unauthorized alteration, forgery or falsification of the content or appearance of this document is unlawful and offenders may be prosecuted to the fullest extent of the law. Unless otherwise stated the results shown in this test report refer only to the sample(s) tested and such sample(s) are retained for 30 days only.

Attention: To check the authenticity of testing /inspection report & certificate, please contact us at telephone: (86-755) 8307 1443, or email: CN.Doccheck@sgs.com
 No.1 Workshop, M-10, Middle Section, Science & Technology Park, Nanshan District, Shenzhen, Guangdong, China 518057 t (86-755) 26012053 f (86-755) 26710594 www.sgs.com.cn
 中国·广东·深圳市南山区科技园中区M-10栋1号厂房 邮编: 518057 t (86-755) 26012053 f (86-755) 26710594 sgs.china@sgs.com

7.4.2 Test Mode Description

Pre-scan / Final test	Mode Code	Description
Final test	14	Charge + TX mode (U-NII-1) _Keep the EUT in continuously transmitting mode with all modulation types and being charged. All data rates for each modulation type have been tested, Only the data of worst case is recorded in the report.
Final test	15	Charge + TX mode (U-NII-2A) _Keep the EUT in continuously transmitting mode with all modulation types and being charged. All data rates for each modulation type have been tested, Only the data of worst case is recorded in the report.
Final test	16	Charge + TX mode (U-NII-2C) _Keep the EUT in continuously transmitting mode with all modulation types and being charged. All data rates for each modulation type have been tested, Only the data of worst case is recorded in the report.
Final test	17	Charge + TX mode (U-NII-3) _Keep the EUT in continuously transmitting mode with all modulation types and being charged. All data rates for each modulation type have been tested, Only the data of worst case is recorded in the report.

7.4.3 Test Setup Diagram

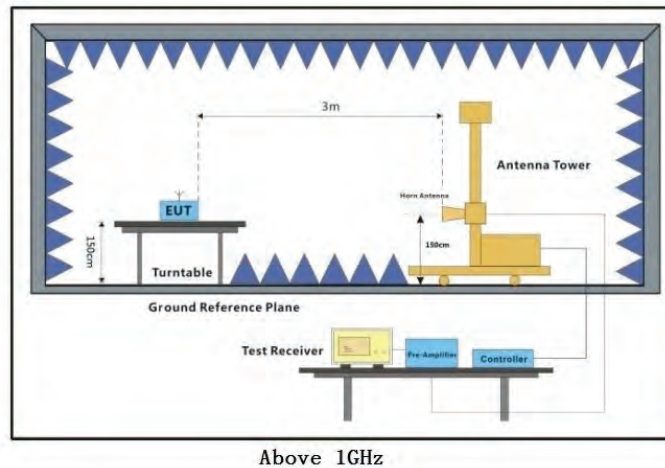

Unless otherwise agreed in writing, this document is issued by the Company subject to its General Conditions of Service printed overleaf, available on request or accessible at <https://www.sgs.com/en/Terms-and-Conditions>. Attention is drawn to the limitation of liability, indemnification and jurisdiction issues defined therein. Any holder of this document is advised that information contained hereon reflects the Company's findings at the time of its intervention only and within the limits of Client's instructions, if any. The Company's sole responsibility is to its Client and this document does not exonerate parties to a transaction from exercising all their rights and obligations under the transaction documents. This document cannot be reproduced except in full, without prior written approval of the Company. Any unauthorized alteration, forgery or falsification of the content or appearance of this document is unlawful and offenders may be prosecuted to the fullest extent of the law. Unless otherwise stated the results shown in this test report refer only to the sample(s) tested and such sample(s) are retained for 30 days only.

Attention: To check the authenticity of testing /inspection report & certificate, please contact us at telephone: (86-755) 8307 1443, or email: CN.Doccheck@sgs.com
 No.1 Workshop, M-10, Middle Section, Science & Technology Park, Nanshan District, Shenzhen, Guangdong, China 518057 t (86-755) 26012053 f (86-755) 26710594 www.sgs.com.cn
 中国·广东·深圳市南山区科技园中区M-10栋1号厂房 邮编: 518057 t (86-755) 26012053 f (86-755) 26710594 sgs.china@sgs.com

7.4.4 Measurement Procedure and Data

- a. For above 1GHz, the EUT was placed on the top of a rotating table 1.5 meters above the ground at a 3 meter fully-anechoic chamber. The table was rotated 360 degrees to determine the position of the highest radiation.
- b. The EUT was set 3 meters away from the interference-receiving antenna, which was mounted on the top of a variable-height antenna tower.
- c. The antenna height is varied from one meter to four meters above the ground to determine the maximum value of the field strength. Both horizontal and vertical polarizations of the antenna are set to make the measurement.
- d. For each suspected emission, the EUT was arranged to its worst case and then the antenna was tuned to heights from 1 meter to 4 meters (for the test frequency of below 30MHz, the antenna was tuned to heights 1 meter) and the rotatable table was turned from 0 degrees to 360 degrees to find the maximum reading.
- e. The test-receiver system was set to Peak Detect Function and Specified Bandwidth with Maximum Hold Mode.
- f. If the emission level of the EUT in peak mode was 10dB lower than the limit specified, then testing could be stopped and the peak values of the EUT would be reported. Otherwise the emissions that did not have 10dB margin would be re-tested one by one using peak or average method as specified and then reported in a data sheet.
- g. Test the EUT in the lowest channel, the middle channel, the Highest channel.
- h. The radiation measurements are performed in X, Y, Z axis positioning for Transmitting mode, and found the X axis positioning which it is the worst case.
- i. Repeat above procedures until all frequencies measured was complete.

Remark:

1. Level= Read Level+ Cable Loss+ Antenna Factor- Preamp Factor
2. Scan from 18GHz to 40GHz, the disturbance above 18GHz was very low. The points marked on above plots are the highest emissions could be found when testing, so only above points had been displayed. The amplitude of spurious emissions from the radiator which are attenuated more than 20dB below the limit need not be reported.
3. As shown in this section, for frequencies above 1GHz, the field strength limits are based on average limits. However, the peak field strength of any emission shall not exceed the maximum permitted average limits specified above by more than 20 dB under any condition of modulation. For the emissions whose peak level is lower than the average limit, only the peak measurement is shown in the report.
4. The disturbance above 18GHz were very low and the harmonics were the highest point could be found when testing, so only the above harmonics had been displayed.
5. For devices with multiple operating modes, measurements on the middle channel is used to determine the worst-case mode(s). Only the worst case mode with the highest output power and the mode with the highest output power spectral density for each modulation family (e.g., OFDM and direct sequence spread spectrum) is recorded in the test report.
6. The resolution bandwidth of test receiver/spectrum analyzer is 1MHz and the video bandwidth is 3MHz for Peak detection (PK) and Average detection (AV) at frequency above 1GHz.
7. For fundamental and harmonic signal measurement, the resolution bandwidth of test receiver/spectrum analyzer is 1MHz and the video bandwidth is $\geq 1/T$ (Duty cycle < 98%) or 10Hz (Duty cycle $\geq 98\%$) for Average detection (AV) at frequency above 1GHz.



11a_TX_CH_36_Horizontal

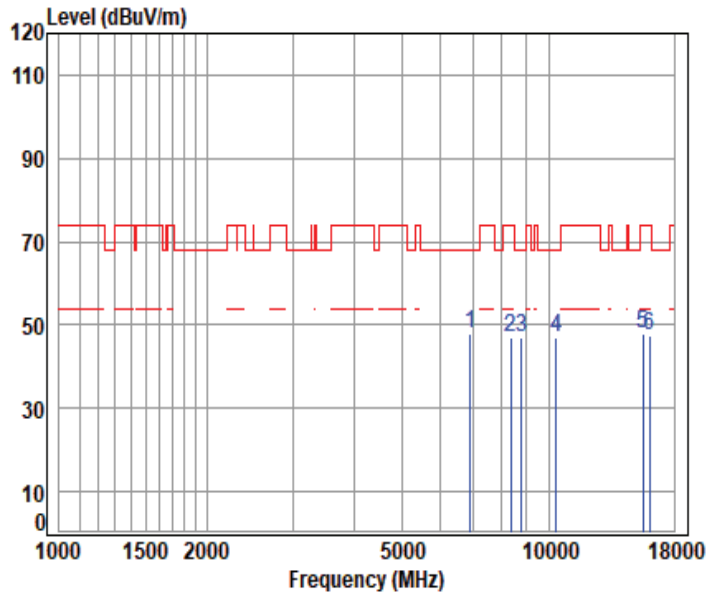

Condition: 3m HORIZONTAL

Job No : 01607WM

Mode : 5180 TX RSE

: 5G Wi-Fi 11a

	Cable	Ant	Preamp	Read	Limit	Over		
Freq	Loss	Factor	Factor	Level	Level	Line	Limit	Remark
MHz	dB	dB/m	dB	dBuV	dBuV/m	dBuV/m	dB	
1 pp 6902.598	11.37	36.19	56.72	56.99	47.83	68.20	-20.37	peak
2 8342.406	11.70	38.58	56.37	53.02	46.93	74.00	-27.07	peak
3 8796.179	12.24	38.50	56.20	52.50	47.04	68.20	-21.16	peak
4 10360.000	13.60	39.00	55.68	50.00	46.92	68.20	-21.28	peak
5 15540.000	17.00	38.56	54.05	46.19	47.70	74.00	-26.30	peak
6 16043.010	17.12	38.56	54.00	45.96	47.64	74.00	-26.36	peak



Unless otherwise agreed in writing, this document is issued by the Company subject to its General Conditions of Service printed overleaf, available on request or accessible at <https://www.sgs.com/en/Terms-and-Conditions>. Attention is drawn to the limitation of liability, indemnification and jurisdiction issues defined therein. Any holder of this document is advised that information contained hereon reflects the Company's findings at the time of its intervention only and within the limits of Client's instructions, if any. The Company's sole responsibility is to its Client and this document does not exonerate parties to a transaction from exercising all their rights and obligations under the transaction documents. This document cannot be reproduced except in full, without prior written approval of the Company. Any unauthorized alteration, forgery or falsification of the content or appearance of this document is unlawful and offenders may be prosecuted to the fullest extent of the law. Unless otherwise stated the results shown in this test report refer only to the sample(s) tested and such sample(s) are retained for 30 days only.

11a_TX_CH_36_Veritical

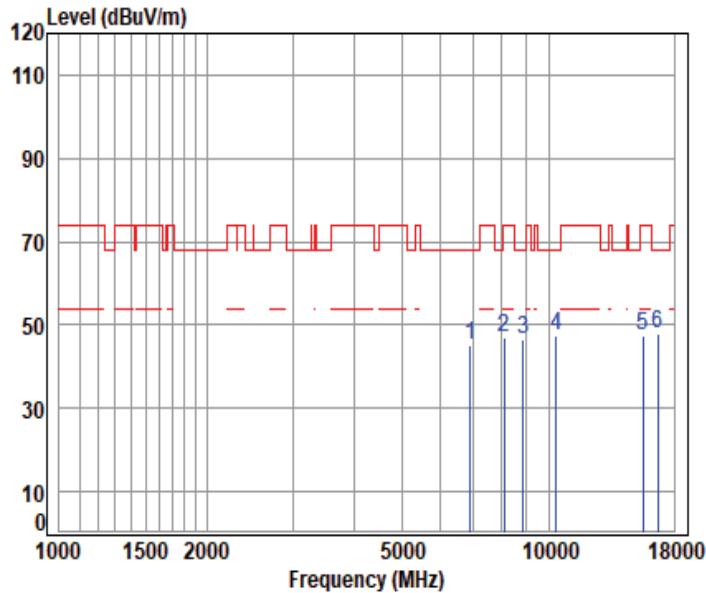

Condition: 3m VERTICAL

Job No : 01607WM

Mode : 5180 TX RSE

: 5G Wi-Fi 11a

	Cable	Ant	Preamp	Read	Limit	Over			
Freq	Loss	Factor	Factor	Level	Level	Line	Limit	Remark	
MHz	dB	dB/m	dB	dBuV	dBuV/m	dBuV/m	dB		
1	6916.673	11.37	36.17	56.73	54.26	45.07	68.20	-23.13 peak	
2	8091.342	11.46	37.80	56.46	54.15	46.95	74.00	-27.05 peak	
3	8850.100	12.23	38.50	56.18	52.20	46.75	68.20	-21.45 peak	
4	10360.000	13.60	39.00	55.68	50.43	47.35	68.20	-20.85 peak	
5	15540.000	17.00	38.56	54.05	45.74	47.25	74.00	-26.75 peak	
6	pp16710.150	17.58	39.42	54.07	44.90	47.83	68.20	-20.37 peak	



11a_TX_CH_44_Horizontal

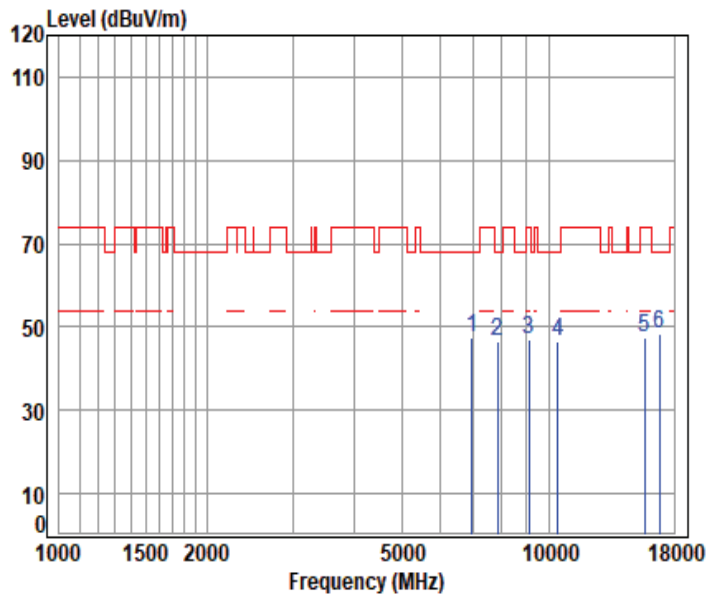

Condition: 3m HORIZONTAL

Job No : 01607WM

Mode : 5220 TX RSE

: 5G Wi-Fi 11a

	Cable	Ant	Preamp	Read	Limit	Over		
Freq	Loss	Factor	Factor	Level	Level	Line	Limit	Remark
MHz	dB	dB/m	dB	dBuV	dBuV/m	dBuV/m	dB	
1	6959.073	11.37	36.12	56.77	56.51	47.23	68.20	-20.97 peak
2	7863.837	11.46	37.46	56.54	54.15	46.53	68.20	-21.67 peak
3	9106.138	12.13	38.61	56.09	52.23	46.88	74.00	-27.12 peak
4	10440.000	13.63	39.04	55.66	49.60	46.61	68.20	-21.59 peak
5	15660.000	17.23	38.56	54.03	45.61	47.37	74.00	-26.63 peak
6	pp16795.470	17.47	39.59	54.08	45.52	48.50	68.20	-19.70 peak



Unless otherwise agreed in writing, this document is issued by the Company subject to its General Conditions of Service printed overleaf, available on request or accessible at <https://www.sgs.com/en/Terms-and-Conditions>. Attention is drawn to the limitation of liability, indemnification and jurisdiction issues defined therein. Any holder of this document is advised that information contained hereon reflects the Company's findings at the time of its intervention only and within the limits of Client's instructions, if any. The Company's sole responsibility is to its Client and this document does not exonerate parties to a transaction from exercising all their rights and obligations under the transaction documents. This document cannot be reproduced except in full, without prior written approval of the Company. Any unauthorized alteration, forgery or falsification of the content or appearance of this document is unlawful and offenders may be prosecuted to the fullest extent of the law. Unless otherwise stated the results shown in this test report refer only to the sample(s) tested and such sample(s) are retained for 30 days only.

Attention: To check the authenticity of testing /inspection report & certificate, please contact us at telephone: (86-755) 8307 1443, or email: CN.Doccheck@sgs.com
 No.1 Workshop, M-10, Middle Section, Science & Technology Park, Nanshan District, Shenzhen, Guangdong, China 518057 t (86-755) 26012053 f (86-755) 26710594 www.sgs.com.cn
 中国·广东·深圳市南山区科技园中区M-10栋1号厂房 邮编: 518057 t (86-755) 26012053 f (86-755) 26710594 sgs.china@sgs.com

11a_TX_CH_44_Vertical

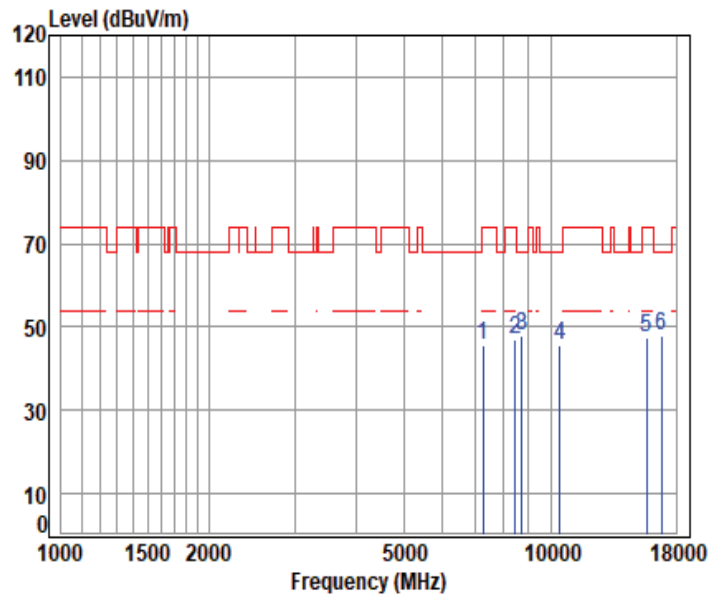

Condition: 3m VERTICAL

Job No : 01607WM

Mode : 5220 TX RSE

: 5G Wi-Fi 11a

	Cable	Ant	Preamp	Read	Limit	Over			
Freq	Loss	Factor	Factor	Level	Level	Line	Limit	Remark	
MHz	dB	dB/m	dB	dBuV	dBuV/m	dBuV/m	dB		
1	7278.053	11.51	36.66	56.71	54.01	45.47	74.00	-28.53 peak	
2	8453.606	11.99	38.39	56.33	53.01	47.06	74.00	-26.94 peak	
3	pp 8715.911	12.12	38.57	56.23	53.37	47.83	68.20	-20.37 peak	
4	10440.000	13.63	39.04	55.66	48.67	45.68	68.20	-22.52 peak	
5	15660.000	17.23	38.56	54.03	45.77	47.53	74.00	-26.47 peak	
6	16778.370	17.49	39.56	54.08	44.83	47.80	68.20	-20.40 peak	



Unless otherwise agreed in writing, this document is issued by the Company subject to its General Conditions of Service printed overleaf, available on request or accessible at <https://www.sgs.com/en/Terms-and-Conditions>. Attention is drawn to the limitation of liability, indemnification and jurisdiction issues defined therein. Any holder of this document is advised that information contained hereon reflects the Company's findings at the time of its intervention only and within the limits of Client's instructions, if any. The Company's sole responsibility is to its Client and this document does not exonerate parties to a transaction from exercising all their rights and obligations under the transaction documents. This document cannot be reproduced except in full, without prior written approval of the Company. Any unauthorized alteration, forgery or falsification of the content or appearance of this document is unlawful and offenders may be prosecuted to the fullest extent of the law. Unless otherwise stated the results shown in this test report refer only to the sample(s) tested and such sample(s) are retained for 30 days only.

Attention: To check the authenticity of testing /inspection report & certificate, please contact us at telephone: (86-755) 8307 1443, or email: CN.Doccheck@sgs.com

11a_TX_CH_48_Horizontal

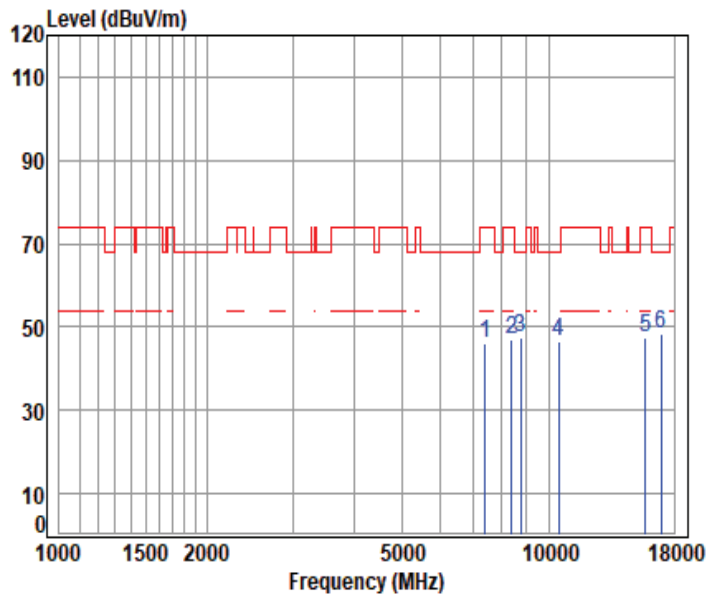

Condition: 3m HORIZONTAL

Job No : 01607WM

Mode : 5240 TX RSE

: 5G Wi-Fi 11a

	Cable	Ant	Preamp	Read	Limit	Over		
Freq	Loss	Factor	Factor	Level	Level	Line	Limit	Remark
MHz	dB	dB/m	dB	dBuV	dBuV/m	dBuV/m	dB	
1	7412.722	11.47	36.73	56.67	54.54	46.07	74.00	-27.93 peak
2	8385.002	11.65	38.63	56.35	53.10	47.03	74.00	-26.97 peak
3	8742.585	12.16	38.51	56.22	53.12	47.57	68.20	-20.63 peak
4	10480.000	13.64	39.08	55.65	49.52	46.59	68.20	-21.61 peak
5	15720.000	17.22	38.58	54.03	45.81	47.58	74.00	-26.42 peak
6	pp16950.140	18.12	39.65	54.10	44.61	48.28	68.20	-19.92 peak



Unless otherwise agreed in writing, this document is issued by the Company subject to its General Conditions of Service printed overleaf, available on request or accessible at <https://www.sgs.com/en/Terms-and-Conditions>. Attention is drawn to the limitation of liability, indemnification and jurisdiction issues defined therein. Any holder of this document is advised that information contained hereon reflects the Company's findings at the time of its intervention only and within the limits of Client's instructions, if any. The Company's sole responsibility is to its Client and this document does not exonerate parties to a transaction from exercising all their rights and obligations under the transaction documents. This document cannot be reproduced except in full, without prior written approval of the Company. Any unauthorized alteration, forgery or falsification of the content or appearance of this document is unlawful and offenders may be prosecuted to the fullest extent of the law. Unless otherwise stated the results shown in this test report refer only to the sample(s) tested and such sample(s) are retained for 30 days only.

Attention: To check the authenticity of testing /inspection report & certificate, please contact us at telephone: (86-755) 8307 1443, or email: CN.Doccheck@sgs.com
 No.1 Workshop, M-10, Middle Section, Science & Technology Park, Nanshan District, Shenzhen, Guangdong, China 518057 t (86-755) 26012053 f (86-755) 26710594 www.sgs.com.cn
 中国·广东·深圳市南山区科技园中区M-10栋1号厂房 邮编: 518057 t (86-755) 26012053 f (86-755) 26710594 sgs.china@sgs.com

11a_TX_CH_48_Veritical

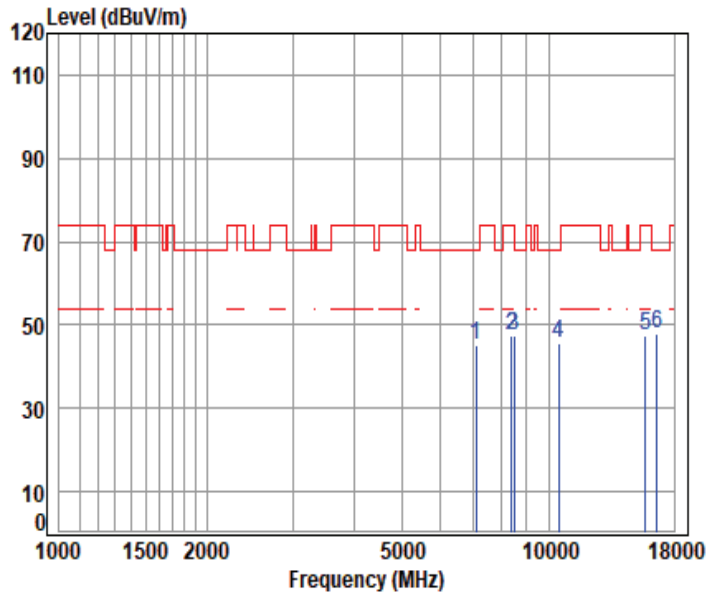

Condition: 3m VERTICAL

Job No : 01607WM

Mode : 5240 TX RSE

: 5G Wi-Fi 11a

	Cable	Ant	Preamp	Read	Limit	Over		
Freq	Loss	Factor	Factor	Level	Level	Line	Limit	Remark
MHz	dB	dB/m	dB	dBuV	dBuV/m	dBuV/m	dB	
1	7095.063	11.96	36.39	56.77	53.55	45.13	68.20	-23.07 peak
2	8385.002	11.65	38.63	56.35	53.34	47.27	74.00	-26.73 peak
3	8496.769	12.29	38.31	56.31	53.25	47.54	74.00	-26.46 peak
4	10480.000	13.64	39.08	55.65	48.66	45.73	68.20	-22.47 peak
5	15720.000	17.22	38.58	54.03	45.65	47.42	74.00	-26.58 peak
6	pp16591.430	17.66	39.17	54.06	44.99	47.76	68.20	-20.44 peak



Unless otherwise agreed in writing, this document is issued by the Company subject to its General Conditions of Service printed overleaf, available on request or accessible at <https://www.sgs.com/en/Terms-and-Conditions>. Attention is drawn to the limitation of liability, indemnification and jurisdiction issues defined therein. Any holder of this document is advised that information contained hereon reflects the Company's findings at the time of its intervention only and within the limits of Client's instructions, if any. The Company's sole responsibility is to its Client and this document does not exonerate parties to a transaction from exercising all their rights and obligations under the transaction documents. This document cannot be reproduced except in full, without prior written approval of the Company. Any unauthorized alteration, forgery or falsification of the content or appearance of this document is unlawful and offenders may be prosecuted to the fullest extent of the law. Unless otherwise stated the results shown in this test report refer only to the sample(s) tested and such sample(s) are retained for 30 days only.

Attention: To check the authenticity of testing /inspection report & certificate, please contact us at telephone: (86-755) 8307 1443, or email: CN.Doccheck@sgs.com
 No.1 Workshop, M-10, Middle Section, Science & Technology Park, Nanshan District, Shenzhen, Guangdong, China 518057 t (86-755) 26012053 f (86-755) 26710594 www.sgsgroup.com.cn
 中国·广东·深圳市南山区科技园中区M-10栋1号厂房 邮编: 518057 t (86-755) 26012053 f (86-755) 26710594 sgs.china@sgs.com

11ax_20M_TX_CH_36_Horizontal

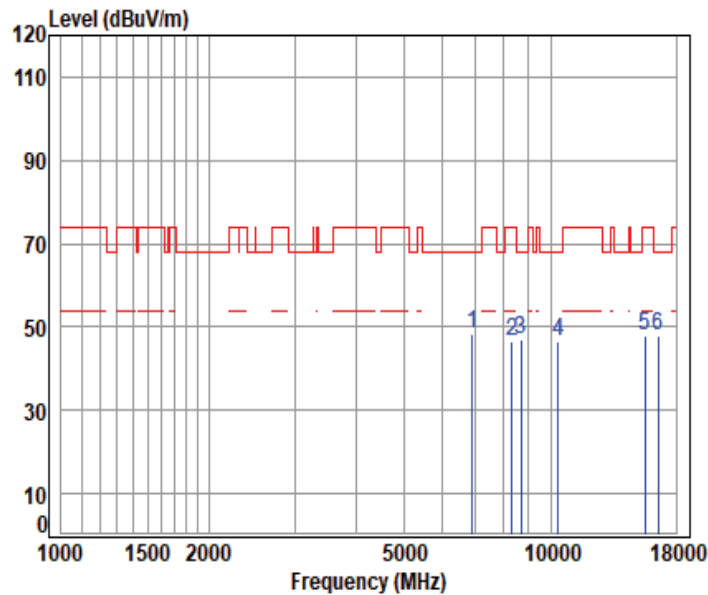

Condition: 3m HORIZONTAL

Job No : 01607WM

Mode : 5180 TX RSE

: 5G Wi-Fi 11ax20

	Cable	Ant	Preamp	Read	Limit	Over			
Freq	Loss	Factor	Factor	Level	Level	Line	Limit	Remark	
MHz	dB	dB/m	dB	dBuV	dBuV/m	dBuV/m	dB		
1 pp 6902.598	11.37	36.19	56.72	57.70	48.54	68.20	-19.66	peak	
2 8325.429	11.73	38.31	56.37	52.79	46.46	74.00	-27.54	peak	
3 8671.635	12.05	38.49	56.25	52.73	47.02	68.20	-21.18	peak	
4 10360.000	13.60	39.00	55.68	49.66	46.58	68.20	-21.62	peak	
5 15540.000	17.00	38.56	54.05	46.38	47.89	74.00	-26.11	peak	
6 16523.970	17.72	38.97	54.05	45.14	47.78	68.20	-20.42	peak	



Unless otherwise agreed in writing, this document is issued by the Company subject to its General Conditions of Service printed overleaf, available on request or accessible at <https://www.sgs.com/en/Terms-and-Conditions>. Attention is drawn to the limitation of liability, indemnification and jurisdiction issues defined therein. Any holder of this document is advised that information contained hereon reflects the Company's findings at the time of its intervention only and within the limits of Client's instructions, if any. The Company's sole responsibility is to its Client and this document does not exonerate parties to a transaction from exercising all their rights and obligations under the transaction documents. This document cannot be reproduced except in full, without prior written approval of the Company. Any unauthorized alteration, forgery or falsification of the content or appearance of this document is unlawful and offenders may be prosecuted to the fullest extent of the law. Unless otherwise stated the results shown in this test report refer only to the sample(s) tested and such sample(s) are retained for 30 days only.

Attention: To check the authenticity of testing /inspection report & certificate, please contact us at telephone: (86-755) 8307 1443, or email: CN.Doccheck@sgs.com
 No.1 Workshop, M-10, Middle Section, Science & Technology Park, Nanshan District, Shenzhen, Guangdong, China 518057 t (86-755) 26012053 f (86-755) 26710594 www.sgsgroup.com.cn
 中国·广东·深圳市南山区科技园中区M-10栋1号厂房 邮编: 518057 t (86-755) 26012053 f (86-755) 26710594 sgs.china@sgs.com

11ax_20M_TX_CH_36_Vertical

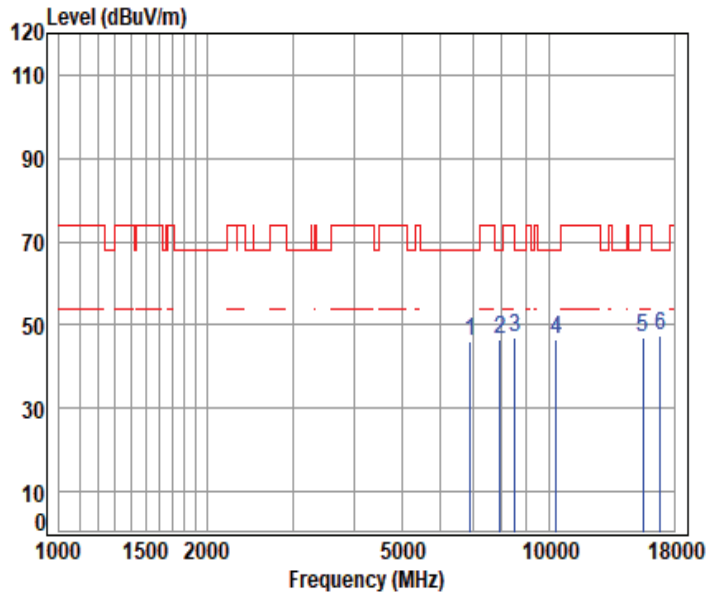

Condition: 3m VERTICAL

Job No : 01607WM

Mode : 5180 TX RSE

: 5G Wi-Fi 11ax20

	Cable	Ant	Preamp	Read	Limit	Over			
Freq	Loss	Factor	Factor	Level	Level	Line	Limit	Remark	
MHz	dB	dB/m	dB	dBuV	dBuV/m	dBuV/m	dB		
1	6902.598	11.37	36.19	56.72	55.44	46.28	68.20	-21.92 peak	
2	7936.257	11.55	37.67	56.52	53.72	46.42	68.20	-21.78 peak	
3	8505.428	12.29	38.30	56.31	52.52	46.80	68.20	-21.40 peak	
4	10360.000	13.60	39.00	55.68	49.50	46.42	68.20	-21.78 peak	
5	15540.000	17.00	38.56	54.05	45.71	47.22	74.00	-26.78 peak	
6	pp16881.220	18.04	39.60	54.09	43.77	47.32	68.20	-20.88 peak	



11ax_20M_TX_CH_44_Horizontal

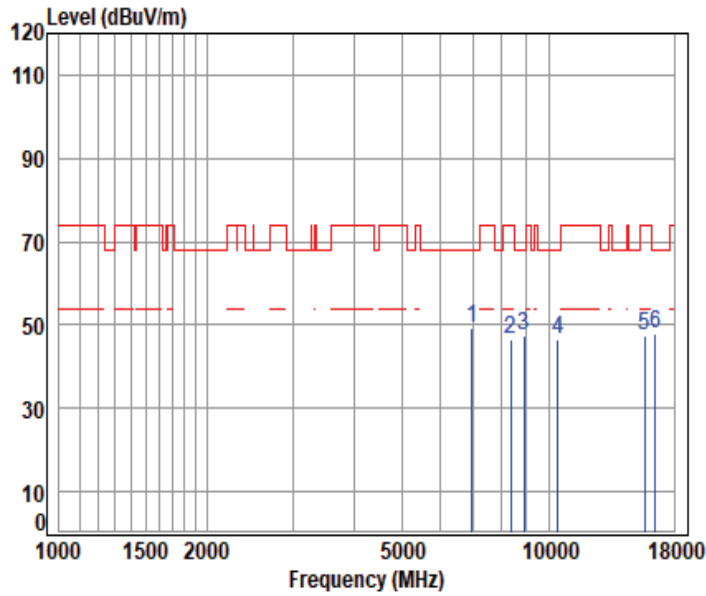

Condition: 3m HORIZONTAL

Job No : 01607WM

Mode : 5220 TX RSE

: 5G Wi-Fi 11ax20

	Cable	Ant	Preamp	Read	Limit	Over			
Freq	Loss	Factor	Factor	Level	Level	Line	Limit	Remark	
MHz	dB	dB/m	dB	dBuV	dBuV/m	dBuV/m	dB		
1 pp 6959.073	11.37	36.12	56.77	58.58	49.30	68.20	-18.90	peak	
2 8342.406	11.70	38.58	56.37	52.81	46.72	74.00	-27.28	peak	
3 8886.231	12.22	38.57	56.17	53.03	47.65	68.20	-20.55	peak	
4 10440.000	13.63	39.04	55.66	49.38	46.39	68.20	-21.81	peak	
5 15660.000	17.23	38.56	54.03	45.65	47.41	74.00	-26.59	peak	
6 16456.780	17.49	38.86	54.05	45.56	47.86	68.20	-20.34	peak	



11ax_20M_TX_CH_44_Vertical

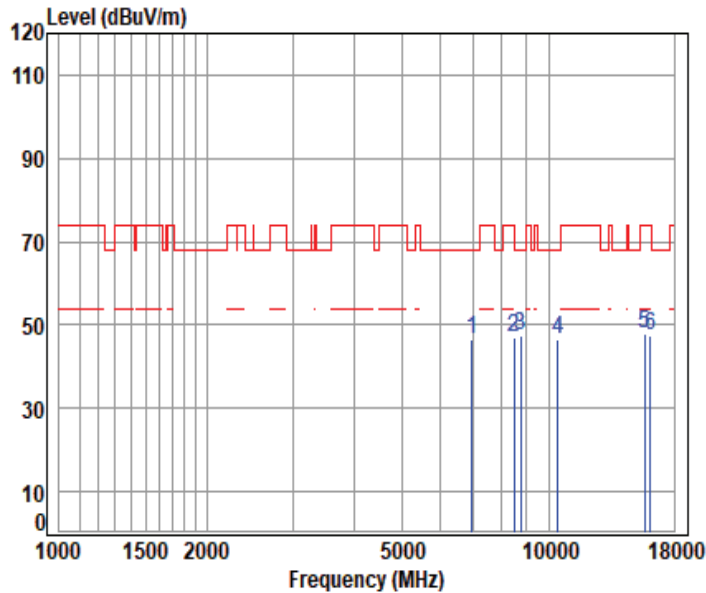

Condition: 3m VERTICAL

Job No : 01607WM

Mode : 5220 TX RSE

: 5G Wi-Fi 11ax20

	Cable	Ant	Preamp	Read	Limit	Over			
Freq	Loss	Factor	Factor	Level	Level	Line	Limit	Remark	
MHz	dB	dB/m	dB	dBuV	dBuV/m	dBuV/m	dB		
1	6959.073	11.37	36.12	56.77	55.79	46.51	68.20	-21.69 peak	
2	8488.119	12.23	38.32	56.31	52.70	46.94	74.00	-27.06 peak	
3	pp 8751.494	12.17	38.50	56.22	53.17	47.62	68.20	-20.58 peak	
4	10440.000	13.63	39.04	55.66	49.46	46.47	68.20	-21.73 peak	
5	15660.000	17.23	38.56	54.03	46.08	47.84	74.00	-26.16 peak	
6	16092.110	17.08	38.51	54.01	46.09	47.67	74.00	-26.33 peak	



Unless otherwise agreed in writing, this document is issued by the Company subject to its General Conditions of Service printed overleaf, available on request or accessible at <https://www.sgs.com/en/Terms-and-Conditions>. Attention is drawn to the limitation of liability, indemnification and jurisdiction issues defined therein. Any holder of this document is advised that information contained hereon reflects the Company's findings at the time of its intervention only and within the limits of Client's instructions, if any. The Company's sole responsibility is to its Client and this document does not exonerate parties to a transaction from exercising all their rights and obligations under the transaction documents. This document cannot be reproduced except in full, without prior written approval of the Company. Any unauthorized alteration, forgery or falsification of the content or appearance of this document is unlawful and offenders may be prosecuted to the fullest extent of the law. Unless otherwise stated the results shown in this test report refer only to the sample(s) tested and such sample(s) are retained for 30 days only.

Attention: To check the authenticity of testing /inspection report & certificate, please contact us at telephone: (86-755) 8307 1443, or email: CN.Doccheck@sgs.com
 No.1 Workshop, M-10, Middle Section, Science & Technology Park, Nanshan District, Shenzhen, Guangdong, China 518057 t (86-755) 26012053 f (86-755) 26710594 www.sgs.com.cn
 中国·广东·深圳市南山区科技园中区M-10栋1号厂房 邮编: 518057 t (86-755) 26012053 f (86-755) 26710594 sgs.china@sgs.com

11ax_20M_TX_CH_48_Horizontal

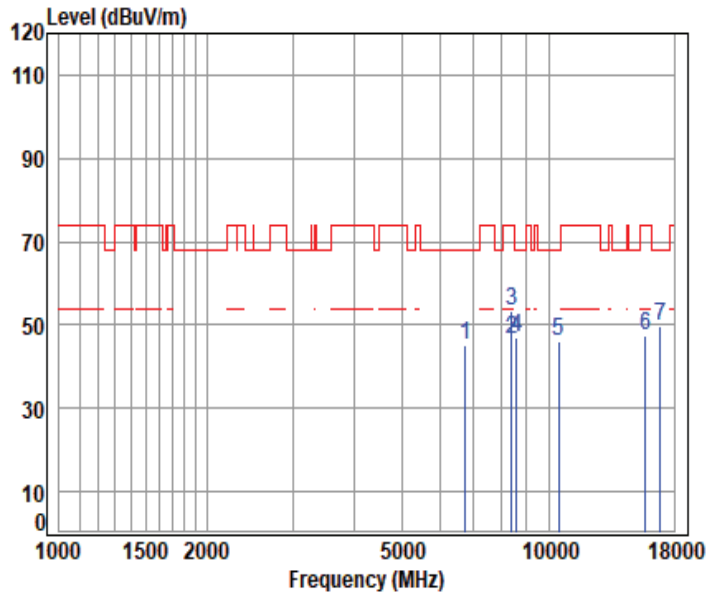

Condition: 3m HORIZONTAL

Job No : 01607WM

Mode : 5240 TX RSE

: 5G Wi-Fi 11ax20

	Cable	Ant	Preamp	Read	Limit	Over		
Freq	Loss	Factor	Factor	Level	Level	Line	Limit	Remark
MHz	dB	dB/m	dB	dBuV	dBuV/m	dBuV/m	dB	
1	6735.905	11.40	35.62	56.58	54.65	45.09	68.20	-23.11 peak
2	pp 8385.002	11.65	38.63	56.35	52.71	46.64	54.00	-7.36 Average
3	8385.002	11.65	38.63	56.35	59.36	53.29	74.00	-20.71 peak
4	8583.757	12.02	38.44	56.28	52.83	47.01	68.20	-21.19 peak
5	10480.000	13.64	39.08	55.65	48.80	45.87	68.20	-22.33 peak
6	15720.000	17.22	38.58	54.03	45.53	47.30	74.00	-26.70 peak
7	pk16864.040	17.92	39.60	54.09	46.50	49.93	68.20	-18.27 peak



Unless otherwise agreed in writing, this document is issued by the Company subject to its General Conditions of Service printed overleaf, available on request or accessible at <https://www.sgs.com/en/Terms-and-Conditions>. Attention is drawn to the limitation of liability, indemnification and jurisdiction issues defined therein. Any holder of this document is advised that information contained hereon reflects the Company's findings at the time of its intervention only and within the limits of Client's instructions, if any. The Company's sole responsibility is to its Client and this document does not exonerate parties to a transaction from exercising all their rights and obligations under the transaction documents. This document cannot be reproduced except in full, without prior written approval of the Company. Any unauthorized alteration, forgery or falsification of the content or appearance of this document is unlawful and offenders may be prosecuted to the fullest extent of the law. Unless otherwise stated the results shown in this test report refer only to the sample(s) tested and such sample(s) are retained for 30 days only.

Attention: To check the authenticity of testing /inspection report & certificate, please contact us at telephone: (86-755) 8307 1443, or email: CN.Doccheck@sgs.com
 No.1 Workshop, M-10, Middle Section, Science & Technology Park, Nanshan District, Shenzhen, Guangdong, China 518057 t (86-755) 26012053 f (86-755) 26710594 www.sgsgroup.com.cn
 中国·广东·深圳市南山区科技园中区M-10栋1号厂房 邮编: 518057 t (86-755) 26012053 f (86-755) 26710594 sgs.china@sgs.com

11ax_20M_TX_CH_48_Vertical

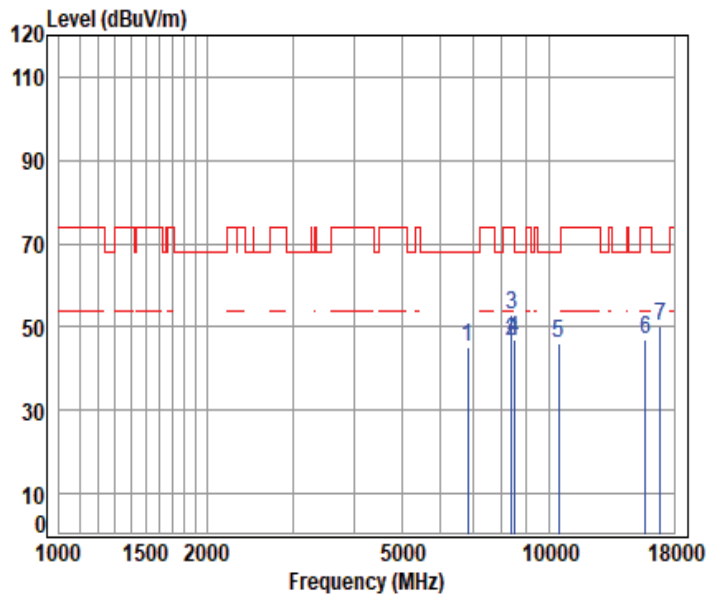

Condition: 3m VERTICAL

Job No : 01607WM

Mode : 5240 TX RSE

: 5G Wi-Fi 11ax20

	Cable Freq	Loss	Ant Factor	Preamp Factor	Read Level	Limit Level	Over Limit	Remark
	MHz	dB	dB/m	dB	dBuV	dBuV/m	dBuV/m	dB
1	6825.690	11.37	35.95	56.65	54.48	45.15	68.20	-23.05 peak
2	pp 8385.002	11.65	38.63	56.35	52.45	46.38	54.00	-7.62 Average
3	8385.002	11.65	38.63	56.35	58.78	52.71	74.00	-21.29 peak
4	8496.769	12.29	38.31	56.31	52.60	46.89	74.00	-27.11 peak
5	10480.000	13.64	39.08	55.65	49.19	46.26	68.20	-21.94 peak
6	15720.000	17.22	38.58	54.03	45.24	47.01	74.00	-26.99 peak
7	pk16864.040	17.92	39.60	54.09	46.60	50.03	68.20	-18.17 peak



Unless otherwise agreed in writing, this document is issued by the Company subject to its General Conditions of Service printed overleaf, available on request or accessible at <https://www.sgs.com/en/Terms-and-Conditions>. Attention is drawn to the limitation of liability, indemnification and jurisdiction issues defined therein. Any holder of this document is advised that information contained hereon reflects the Company's findings at the time of its intervention only and within the limits of Client's instructions, if any. The Company's sole responsibility is to its Client and this document does not exonerate parties to a transaction from exercising all their rights and obligations under the transaction documents. This document cannot be reproduced except in full, without prior written approval of the Company. Any unauthorized alteration, forgery or falsification of the content or appearance of this document is unlawful and offenders may be prosecuted to the fullest extent of the law. Unless otherwise stated the results shown in this test report refer only to the sample(s) tested and such sample(s) are retained for 30 days only.

Attention: To check the authenticity of testing /inspection report & certificate, please contact us at telephone: (86-755) 8307 1443, or email: CN.Doccheck@sgs.com
 No.1 Workshop, M-10, Middle Section, Science & Technology Park, Nanshan District, Shenzhen, Guangdong, China 518057 t (86-755) 26012053 f (86-755) 26710594 www.sgs.com.cn
 中国·广东·深圳市南山区科技园中区M-10栋1号厂房 邮编: 518057 t (86-755) 26012053 f (86-755) 26710594 sgs.china@sgs.com

11a_TX_CH_52_Horizontal

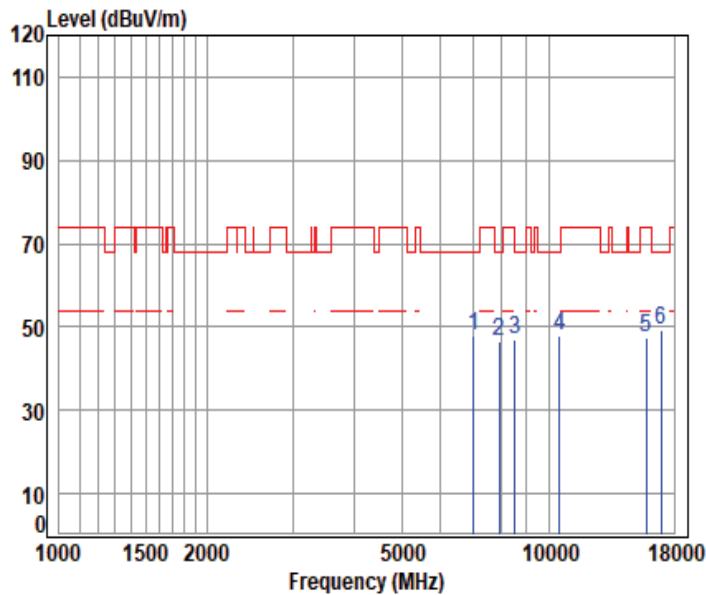

Condition: 3m HORIZONTAL

Job No : 01607WM

Mode : 5260 TX RSE

: 5G Wi-Fi 11a

	Cable	Ant	Preamp	Read	Limit	Over			
Freq	Loss	Factor	Factor	Level	Level	Line	Limit	Remark	
MHz	dB	dB/m	dB	dBuV	dBuV/m	dBuV/m	dB		
1	7016.012	11.47	36.23	56.79	57.04	47.95	68.20	-20.25 peak	
2	7928.178	11.55	37.66	56.52	53.69	46.38	68.20	-21.82 peak	
3	8522.772	12.23	38.30	56.30	52.81	47.04	68.20	-21.16 peak	
4	10520.000	13.63	39.14	55.63	50.63	47.77	68.20	-20.43 peak	
5	15780.000	17.08	38.52	54.02	46.00	47.58	74.00	-26.42 peak	
6	pp16915.650	18.16	39.62	54.09	45.39	49.08	68.20	-19.12 peak	



11a_TX_CH_52_Vertical

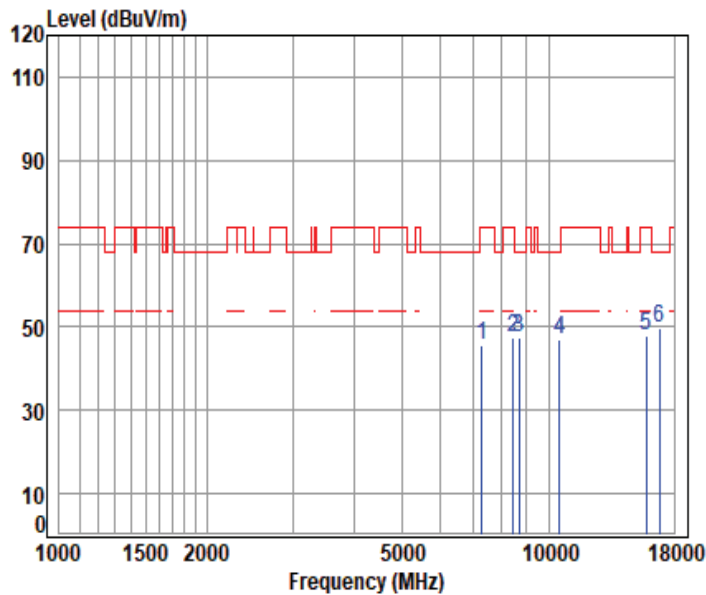

Condition: 3m VERTICAL

Job No : 01607WM

Mode : 5260 TX RSE

: 5G Wi-Fi 11a

	Cable	Ant	Preamp	Read	Limit	Over		
Freq	Loss	Factor	Factor	Level	Level	Line	Limit	Remark
MHz	dB	dB/m	dB	dBuV	dBuV/m	dBuV/m	dB	
1	7285.470	11.51	36.67	56.71	54.01	45.48	74.00	-28.52 peak
2	8462.222	12.05	38.38	56.32	53.30	47.41	74.00	-26.59 peak
3	8689.318	12.08	38.56	56.24	53.06	47.46	68.20	-20.74 peak
4	10520.000	13.63	39.14	55.63	49.71	46.85	68.20	-21.35 peak
5	15780.000	17.08	38.52	54.02	46.26	47.84	74.00	-26.16 peak
6	pp16795.470	17.47	39.59	54.08	46.64	49.62	68.20	-18.58 peak



Unless otherwise agreed in writing, this document is issued by the Company subject to its General Conditions of Service printed overleaf, available on request or accessible at <https://www.sgs.com/en/Terms-and-Conditions>. Attention is drawn to the limitation of liability, indemnification and jurisdiction issues defined therein. Any holder of this document is advised that information contained hereon reflects the Company's findings at the time of its intervention only and within the limits of Client's instructions, if any. The Company's sole responsibility is to its Client and this document does not exonerate parties to a transaction from exercising all their rights and obligations under the transaction documents. This document cannot be reproduced except in full, without prior written approval of the Company. Any unauthorized alteration, forgery or falsification of the content or appearance of this document is unlawful and offenders may be prosecuted to the fullest extent of the law. Unless otherwise stated the results shown in this test report refer only to the sample(s) tested and such sample(s) are retained for 30 days only.

Attention: To check the authenticity of testing /inspection report & certificate, please contact us at telephone: (86-755) 8307 1443, or email: CN.Doccheck@sgs.com

11a_TX_CH_60_Horizontal

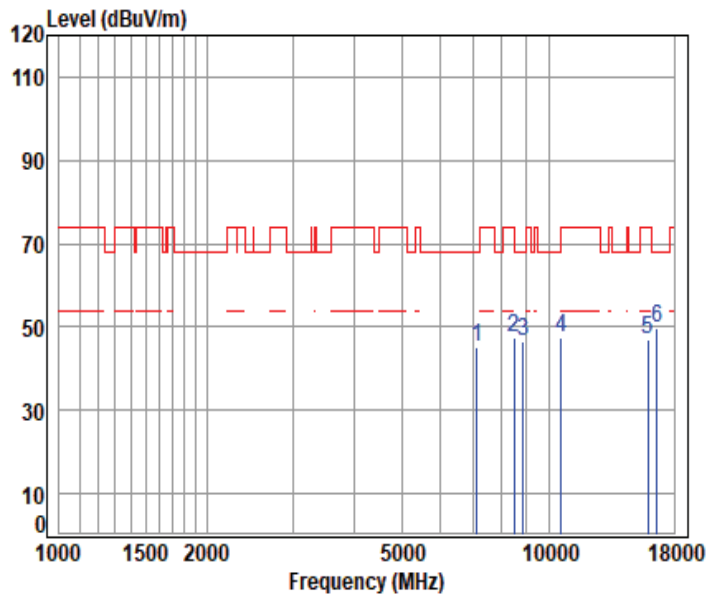

Condition: 3m HORIZONTAL

Job No : 01607WM

Mode : 5300 TX RSE

: 5G Wi-Fi 11a

	Cable	Ant	Preamp	Read	Limit	Over			
Freq	Loss	Factor	Factor	Level	Level	Line	Limit	Remark	
MHz	dB	dB/m	dB	dBuV	dBuV/m	dBuV/m	dB		
1	7116.776	11.91	36.43	56.76	53.65	45.23	68.20	-22.97 peak	
2	8479.478	12.17	38.34	56.32	53.42	47.61	74.00	-26.39 peak	
3	8859.119	12.23	38.52	56.18	52.18	46.75	68.20	-21.45 peak	
4	10600.000	13.59	39.30	55.61	49.98	47.26	68.20	-20.94 peak	
5	15900.000	17.28	38.70	54.01	45.17	47.14	74.00	-26.86 peak	
6	pp16591.430	17.66	39.17	54.06	46.76	49.53	68.20	-18.67 peak	



Unless otherwise agreed in writing, this document is issued by the Company subject to its General Conditions of Service printed overleaf, available on request or accessible at <https://www.sgs.com/en/Terms-and-Conditions>. Attention is drawn to the limitation of liability, indemnification and jurisdiction issues defined therein. Any holder of this document is advised that information contained hereon reflects the Company's findings at the time of its intervention only and within the limits of Client's instructions, if any. The Company's sole responsibility is to its Client and this document does not exonerate parties to a transaction from exercising all their rights and obligations under the transaction documents. This document cannot be reproduced except in full, without prior written approval of the Company. Any unauthorized alteration, forgery or falsification of the content or appearance of this document is unlawful and offenders may be prosecuted to the fullest extent of the law. Unless otherwise stated the results shown in this test report refer only to the sample(s) tested and such sample(s) are retained for 30 days only.

Attention: To check the authenticity of testing /inspection report & certificate, please contact us at telephone: (86-755) 8307 1443, or email: CN.Doccheck@sgs.com
 No.1 Workshop, M-10, Middle Section, Science & Technology Park, Nanshan District, Shenzhen, Guangdong, China 518057 t (86-755) 26012053 f (86-755) 26710594 www.sgs.com.cn
 中国·广东·深圳市南山区科技园中区M-10栋1号厂房 邮编: 518057 t (86-755) 26012053 f (86-755) 26710594 sgs.china@sgs.com

11a_TX_CH_60_Vertical

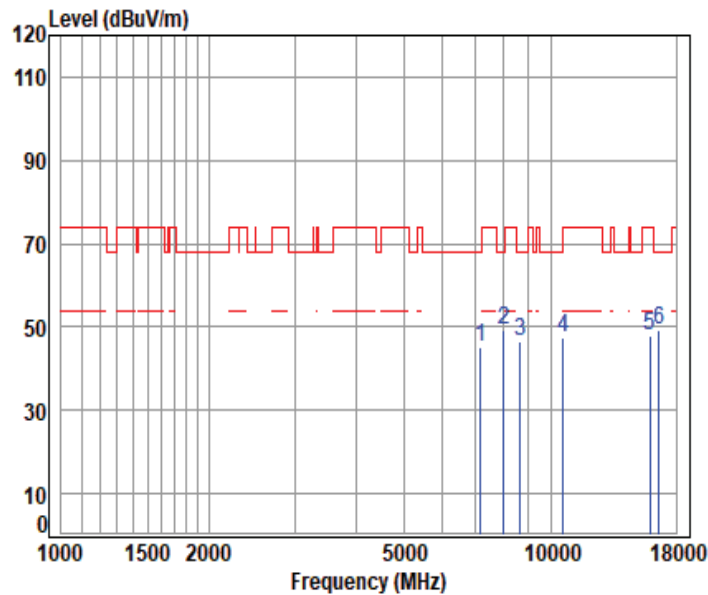

Condition: 3m VERTICAL

Job No : 01607WM

Mode : 5300 TX RSE

: 5G Wi-Fi 11a

	Cable	Ant	Preamp	Read	Limit	Over		
Freq	Loss	Factor	Factor	Level	Level	Line	Limit	Remark
MHz	dB	dB/m	dB	dBuV	dBuV/m	dBuV/m	dB	
1	7167.700	11.67	36.54	56.75	53.93	45.39	68.20	-22.81 peak
2	7993.045	11.56	37.79	56.50	56.52	49.37	68.20	-18.83 peak
3	8653.987	12.03	38.42	56.25	52.42	46.62	68.20	-21.58 peak
4	10600.000	13.59	39.30	55.61	50.01	47.29	68.20	-20.91 peak
5	15900.000	17.28	38.70	54.01	45.94	47.91	74.00	-26.09 peak
6	pp16668.340	17.64	39.22	54.06	46.65	49.45	68.20	-18.75 peak



11a_TX_CH_64_Horizontal

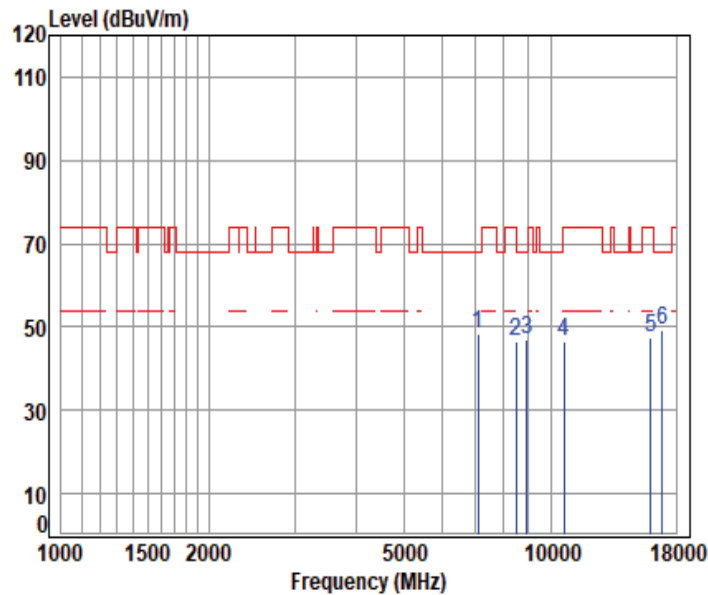

Condition: 3m HORIZONTAL

Job No : 01607WM

Mode : 5320 TX RSE

: 5G Wi-Fi 11a

	Cable	Ant	Preamp	Read	Limit	Over			
Freq	Loss	Factor	Factor	Level	Level	Line	Limit	Remark	
MHz	dB	dB/m	dB	dBuV	dBuV/m	dBuV/m	dB		
1	7095.063	11.96	36.39	56.77	56.79	48.37	68.20	-19.83 peak	
2	8488.119	12.23	38.32	56.31	52.29	46.53	74.00	-27.47 peak	
3	8913.427	12.21	38.57	56.16	52.46	47.08	68.20	-21.12 peak	
4	10640.000	13.77	39.34	55.60	48.93	46.44	74.00	-27.56 peak	
5	15960.000	17.20	38.64	54.00	45.72	47.56	74.00	-26.44 peak	
6	pp16864.040	17.92	39.60	54.09	45.87	49.30	68.20	-18.90 peak	



Unless otherwise agreed in writing, this document is issued by the Company subject to its General Conditions of Service printed overleaf, available on request or accessible at <https://www.sgs.com/en/Terms-and-Conditions>. Attention is drawn to the limitation of liability, indemnification and jurisdiction issues defined therein. Any holder of this document is advised that information contained hereon reflects the Company's findings at the time of its intervention only and within the limits of Client's instructions, if any. The Company's sole responsibility is to its Client and this document does not exonerate parties to a transaction from exercising all their rights and obligations under the transaction documents. This document cannot be reproduced except in full, without prior written approval of the Company. Any unauthorized alteration, forgery or falsification of the content or appearance of this document is unlawful and offenders may be prosecuted to the fullest extent of the law. Unless otherwise stated the results shown in this test report refer only to the sample(s) tested and such sample(s) are retained for 30 days only.

Attention: To check the authenticity of testing /inspection report & certificate, please contact us at telephone: (86-755) 8307 1443, or email: CN.Doccheck@sgs.com
 No.1 Workshop, M-10, Middle Section, Science & Technology Park, Nanshan District, Shenzhen, Guangdong, China 518057 t (86-755) 26012053 f (86-755) 26710594 www.sgsgroup.com.cn
 中国·广东·深圳市南山区科技园中区M-10栋1号厂房 邮编: 518057 t (86-755) 26012053 f (86-755) 26710594 sgs.china@sgs.com

11a_TX_CH_64_Veritical

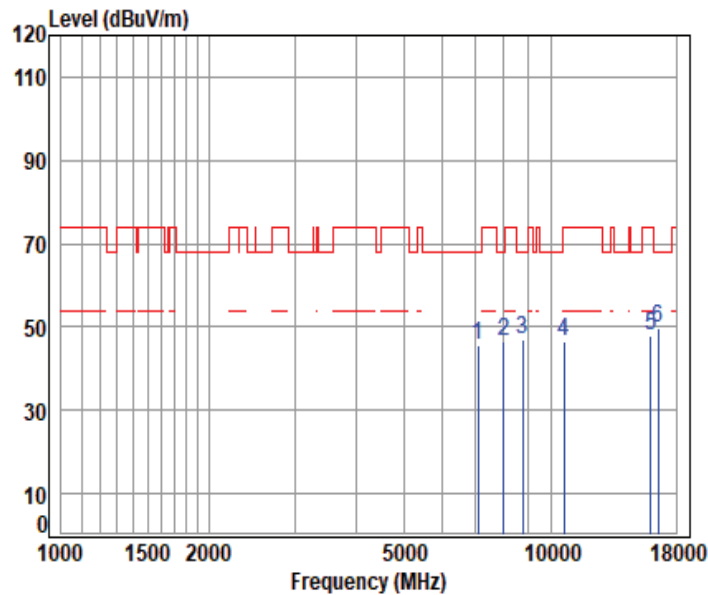

Condition: 3m VERTICAL

Job No : 01607WM

Mode : 5320 TX RSE

: 5G Wi-Fi 11a

	Cable	Ant	Preamp	Read	Limit	Over			
Freq	Loss	Factor	Factor	Level	Level	Line	Limit	Remark	
MHz	dB	dB/m	dB	dBuV	dBuV/m	dBuV/m	dB		
1	7095.063	11.96	36.39	56.77	54.24	45.82	68.20	-22.38 peak	
2	7993.045	11.56	37.79	56.50	53.84	46.69	68.20	-21.51 peak	
3	8742.585	12.16	38.51	56.22	52.32	46.77	68.20	-21.43 peak	
4	10640.000	13.77	39.34	55.60	48.94	46.45	74.00	-27.55 peak	
5	15960.000	17.20	38.64	54.00	46.04	47.88	74.00	-26.12 peak	
6	pp16574.540	17.67	39.12	54.06	47.01	49.74	68.20	-18.46 peak	



Unless otherwise agreed in writing, this document is issued by the Company subject to its General Conditions of Service printed overleaf, available on request or accessible at <https://www.sgs.com/en/Terms-and-Conditions>. Attention is drawn to the limitation of liability, indemnification and jurisdiction issues defined therein. Any holder of this document is advised that information contained hereon reflects the Company's findings at the time of its intervention only and within the limits of Client's instructions, if any. The Company's sole responsibility is to its Client and this document does not exonerate parties to a transaction from exercising all their rights and obligations under the transaction documents. This document cannot be reproduced except in full, without prior written approval of the Company. Any unauthorized alteration, forgery or falsification of the content or appearance of this document is unlawful and offenders may be prosecuted to the fullest extent of the law. Unless otherwise stated the results shown in this test report refer only to the sample(s) tested and such sample(s) are retained for 30 days only.

Attention: To check the authenticity of testing /inspection report & certificate, please contact us at telephone: (86-755) 8307 1443, or email: CN.Doccheck@sgs.com

11ax_20M_TX_CH_52_Horizontal

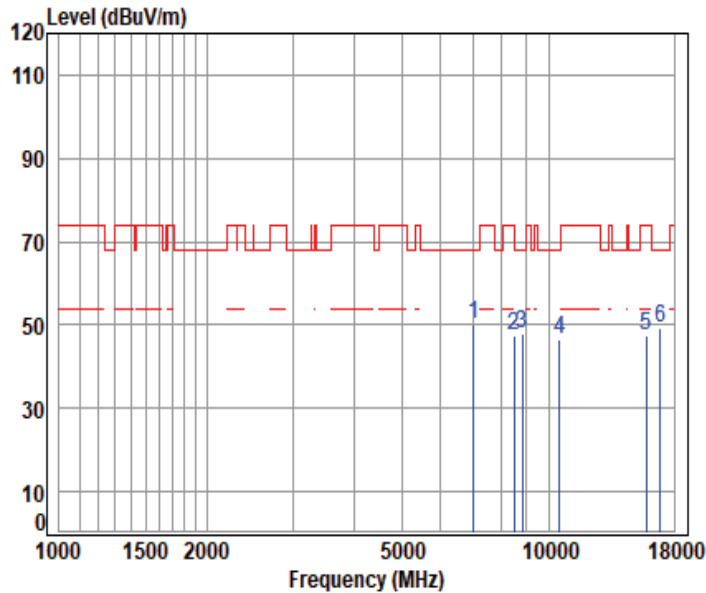

Condition: 3m HORIZONTAL

Job No : 01607WM

Mode : 5260 TX RSE

: 5G Wi-Fi 11ax20

	Cable	Ant	Preamp	Read	Limit	Over			
Freq	Loss	Factor	Factor	Level	Level	Line	Limit	Remark	
MHz	dB	dB/m	dB	dBuV	dBuV/m	dBuV/m	dB		
1 pp 7016.012	11.47	36.23	56.79	59.32	50.23	68.20	-17.97	peak	
2 8496.769	12.29	38.31	56.31	53.21	47.50	74.00	-26.50	peak	
3 8823.098	12.24	38.50	56.19	53.44	47.99	68.20	-20.21	peak	
4 10520.000	13.63	39.14	55.63	49.21	46.35	68.20	-21.85	peak	
5 15780.000	17.08	38.52	54.02	45.88	47.46	74.00	-26.54	peak	
6 16881.220	18.04	39.60	54.09	45.58	49.13	68.20	-19.07	peak	



Unless otherwise agreed in writing, this document is issued by the Company subject to its General Conditions of Service printed overleaf, available on request or accessible at <https://www.sgs.com/en/Terms-and-Conditions>. Attention is drawn to the limitation of liability, indemnification and jurisdiction issues defined therein. Any holder of this document is advised that information contained hereon reflects the Company's findings at the time of its intervention only and within the limits of Client's instructions, if any. The Company's sole responsibility is to its Client and this document does not exonerate parties to a transaction from exercising all their rights and obligations under the transaction documents. This document cannot be reproduced except in full, without prior written approval of the Company. Any unauthorized alteration, forgery or falsification of the content or appearance of this document is unlawful and offenders may be prosecuted to the fullest extent of the law. Unless otherwise stated the results shown in this test report refer only to the sample(s) tested and such sample(s) are retained for 30 days only.

11ax_20M_TX_CH_52_Vertical

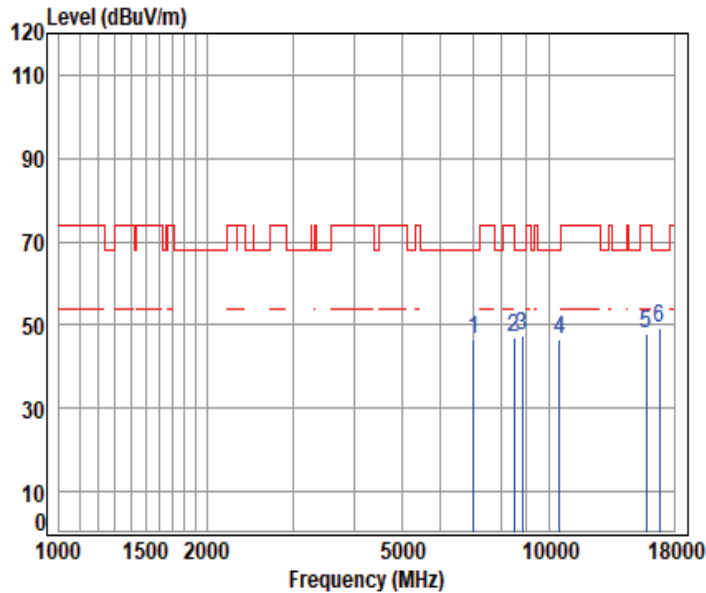

Condition: 3m VERTICAL

Job No : 01607WM

Mode : 5260 TX RSE

: 5G Wi-Fi 11ax20

	Cable	Ant	Preamp	Read	Limit	Over			
Freq	Loss	Factor	Factor	Level	Level	Line	Limit	Remark	
MHz	dB	dB/m	dB	dBuV	dBuV/m	dBuV/m	dB		
1	7016.012	11.47	36.23	56.79	55.78	46.69	68.20	-21.51 peak	
2	8496.769	12.29	38.31	56.31	52.59	46.88	74.00	-27.12 peak	
3	8832.090	12.24	38.50	56.19	52.72	47.27	68.20	-20.93 peak	
4	10520.000	13.63	39.14	55.63	49.39	46.53	68.20	-21.67 peak	
5	15780.000	17.08	38.52	54.02	46.21	47.79	74.00	-26.21 peak	
6	pp16812.580	17.55	39.60	54.08	46.25	49.32	68.20	-18.88 peak	



Unless otherwise agreed in writing, this document is issued by the Company subject to its General Conditions of Service printed overleaf, available on request or accessible at <https://www.sgs.com/en/Terms-and-Conditions>. Attention is drawn to the limitation of liability, indemnification and jurisdiction issues defined therein. Any holder of this document is advised that information contained hereon reflects the Company's findings at the time of its intervention only and within the limits of Client's instructions, if any. The Company's sole responsibility is to its Client and this document does not exonerate parties to a transaction from exercising all their rights and obligations under the transaction documents. This document cannot be reproduced except in full, without prior written approval of the Company. Any unauthorized alteration, forgery or falsification of the content or appearance of this document is unlawful and offenders may be prosecuted to the fullest extent of the law. Unless otherwise stated the results shown in this test report refer only to the sample(s) tested and such sample(s) are retained for 30 days only.

Attention: To check the authenticity of testing /inspection report & certificate, please contact us at telephone: (86-755) 8307 1443, or email: CN.Doccheck@sgs.com
 No.1 Workshop, M-10, Middle Section, Science & Technology Park, Nanshan District, Shenzhen, Guangdong, China 518057 t (86-755) 26012053 f (86-755) 26710594 www.sgs.com.cn
 中国·广东·深圳市南山区科技园中区M-10栋1号厂房 邮编: 518057 t (86-755) 26012053 f (86-755) 26710594 sgs.china@sgs.com

11ax_20M_TX_CH_60_Horizontal

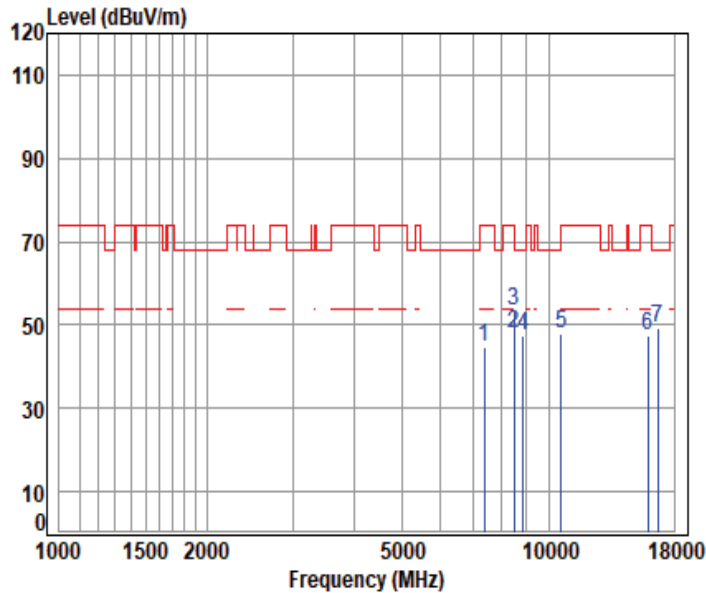

Condition: 3m HORIZONTAL

Job No : 01607WM

Mode : 5300 TX RSE

: 5G Wi-Fi 11ax20

	Cable	Ant	Preamp	Read	Limit	Over		
Freq	Loss	Factor	Factor	Level	Level	Line	Limit	Remark
MHz	dB	dB/m	dB	dBuV	dBuV/m	dBuV/m	dB	
1	7367.558	11.50	36.76	56.69	53.35	44.92	74.00	-29.08 peak
2	pp 8479.478	12.17	38.34	56.32	53.57	47.76	54.00	-6.24 Average
3	8479.478	12.17	38.34	56.32	59.14	53.33	74.00	-20.67 peak
4	8850.100	12.23	38.50	56.18	52.90	47.45	68.20	-20.75 peak
5	10600.000	13.59	39.30	55.61	50.60	47.88	68.20	-20.32 peak
6	15900.000	17.28	38.70	54.01	45.30	47.27	74.00	-26.73 peak
7	pk16710.150	17.58	39.42	54.07	46.38	49.31	68.20	-18.89 peak



Unless otherwise agreed in writing, this document is issued by the Company subject to its General Conditions of Service printed overleaf, available on request or accessible at <https://www.sgs.com/en/Terms-and-Conditions>. Attention is drawn to the limitation of liability, indemnification and jurisdiction issues defined therein. Any holder of this document is advised that information contained hereon reflects the Company's findings at the time of its intervention only and within the limits of Client's instructions, if any. The Company's sole responsibility is to its Client and this document does not exonerate parties to a transaction from exercising all their rights and obligations under the transaction documents. This document cannot be reproduced except in full, without prior written approval of the Company. Any unauthorized alteration, forgery or falsification of the content or appearance of this document is unlawful and offenders may be prosecuted to the fullest extent of the law. Unless otherwise stated the results shown in this test report refer only to the sample(s) tested and such sample(s) are retained for 30 days only.

Attention: To check the authenticity of testing /inspection report & certificate, please contact us at telephone: (86-755) 8307 1443, or email: CN.Doccheck@sgs.com
 No.1 Workshop, M-10, Middle Section, Science & Technology Park, Nanshan District, Shenzhen, Guangdong, China 518057 t (86-755) 26012053 f (86-755) 26710594 www.sgs.com.cn
 中国·广东·深圳市南山区科技园中区M-10栋1号厂房 邮编: 518057 t (86-755) 26012053 f (86-755) 26710594 sgs.china@sgs.com

11ax_20M_TX_CH_60_Vertical

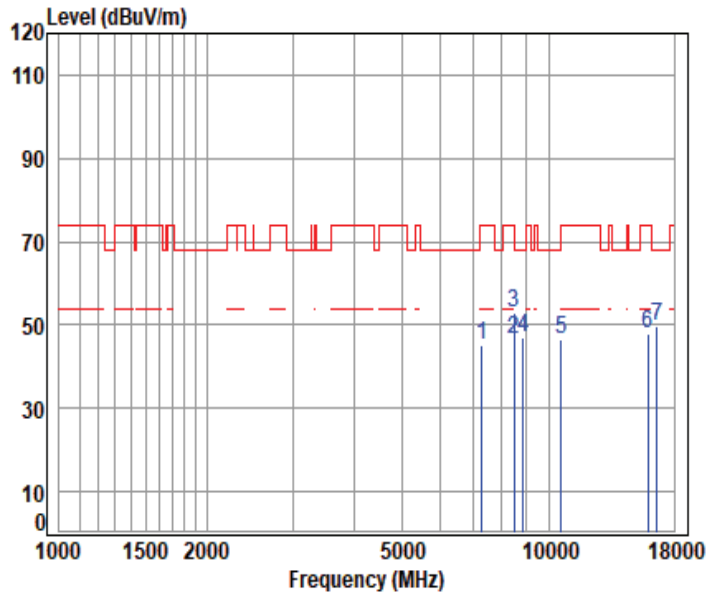

Condition: 3m VERTICAL

Job No : 01607WM

Mode : 5300 TX RSE

: 5G Wi-Fi 11ax20

	Cable	Ant	Preamp	Read	Limit	Over		
Freq	Loss	Factor	Factor	Level	Level	Line	Limit	Remark
MHz	dB	dB/m	dB	dBuV	dBuV/m	dBuV/m	dB	
1	7285.470	11.51	36.67	56.71	53.67	45.14	74.00	-28.86 peak
2	pp 8479.478	12.17	38.34	56.32	52.29	46.48	54.00	-7.52 Average
3	8479.478	12.17	38.34	56.32	58.78	52.97	74.00	-21.03 peak
4	8850.100	12.23	38.50	56.18	52.44	46.99	68.20	-21.21 peak
5	10600.000	13.59	39.30	55.61	49.43	46.71	68.20	-21.49 peak
6	15900.000	17.28	38.70	54.01	45.82	47.79	74.00	-26.21 peak
7	pk16625.260	17.63	39.25	54.07	46.73	49.54	68.20	-18.66 peak



Unless otherwise agreed in writing, this document is issued by the Company subject to its General Conditions of Service printed overleaf, available on request or accessible at <https://www.sgs.com/en/Terms-and-Conditions>. Attention is drawn to the limitation of liability, indemnification and jurisdiction issues defined therein. Any holder of this document is advised that information contained hereon reflects the Company's findings at the time of its intervention only and within the limits of Client's instructions, if any. The Company's sole responsibility is to its Client and this document does not exonerate parties to a transaction from exercising all their rights and obligations under the transaction documents. This document cannot be reproduced except in full, without prior written approval of the Company. Any unauthorized alteration, forgery or falsification of the content or appearance of this document is unlawful and offenders may be prosecuted to the fullest extent of the law. Unless otherwise stated the results shown in this test report refer only to the sample(s) tested and such sample(s) are retained for 30 days only.

Attention: To check the authenticity of testing /inspection report & certificate, please contact us at telephone: (86-755) 8307 1443, or email: CN.Doccheck@sgs.com
 No.1 Workshop, M-10, Middle Section, Science & Technology Park, Nanshan District, Shenzhen, Guangdong, China 518057 t (86-755) 26012053 f (86-755) 26710594 www.sgs.com.cn
 中国·广东·深圳市南山区科技园中区M-10栋1号厂房 邮编: 518057 t (86-755) 26012053 f (86-755) 26710594 sgs.china@sgs.com

11ax_20M_TX_CH_64_Horizontal

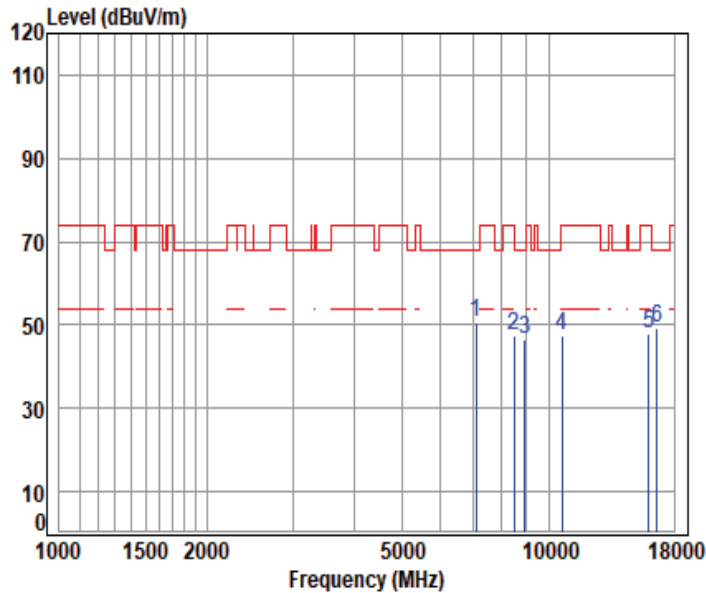

Condition: 3m HORIZONTAL

Job No : 01607WM

Mode : 5320 TX RSE

: 5G Wi-Fi 11ax20

	Cable	Ant	Preamp	Read	Limit	Over			
Freq	Loss	Factor	Factor	Level	Level	Line	Limit	Remark	
MHz	dB	dB/m	dB	dBuV	dBuV/m	dBuV/m	dB		
1 pp 7095.063	11.96	36.39	56.77	59.00	50.58	68.20	-17.62	peak	
2 8488.119	12.23	38.32	56.31	53.08	47.32	74.00	-26.68	peak	
3 8931.603	12.20	38.54	56.15	52.09	46.68	68.20	-21.52	peak	
4 10640.000	13.77	39.34	55.60	49.74	47.25	74.00	-26.75	peak	
5 15960.000	17.20	38.64	54.00	46.03	47.87	74.00	-26.13	peak	
6 16608.340	17.64	39.22	54.06	46.61	49.41	68.20	-18.79	peak	



Unless otherwise agreed in writing, this document is issued by the Company subject to its General Conditions of Service printed overleaf, available on request or accessible at <https://www.sgs.com/en/Terms-and-Conditions>. Attention is drawn to the limitation of liability, indemnification and jurisdiction issues defined therein. Any holder of this document is advised that information contained hereon reflects the Company's findings at the time of its intervention only and within the limits of Client's instructions, if any. The Company's sole responsibility is to its Client and this document does not exonerate parties to a transaction from exercising all their rights and obligations under the transaction documents. This document cannot be reproduced except in full, without prior written approval of the Company. Any unauthorized alteration, forgery or falsification of the content or appearance of this document is unlawful and offenders may be prosecuted to the fullest extent of the law. Unless otherwise stated the results shown in this test report refer only to the sample(s) tested and such sample(s) are retained for 30 days only.

Attention: To check the authenticity of testing /inspection report & certificate, please contact us at telephone: (86-755) 8307 1443, or email: CN.Doccheck@sgs.com
 No.1 Workshop, M-10, Middle Section, Science & Technology Park, Nanshan District, Shenzhen, Guangdong, China 518057 t (86-755) 26012053 f (86-755) 26710594 www.sgsgroup.com.cn
 中国·广东·深圳市南山区科技园中区M-10栋1号厂房 邮编: 518057 t (86-755) 26012053 f (86-755) 26710594 sgs.china@sgs.com

11ax_20M_TX_CH_64_Vertical

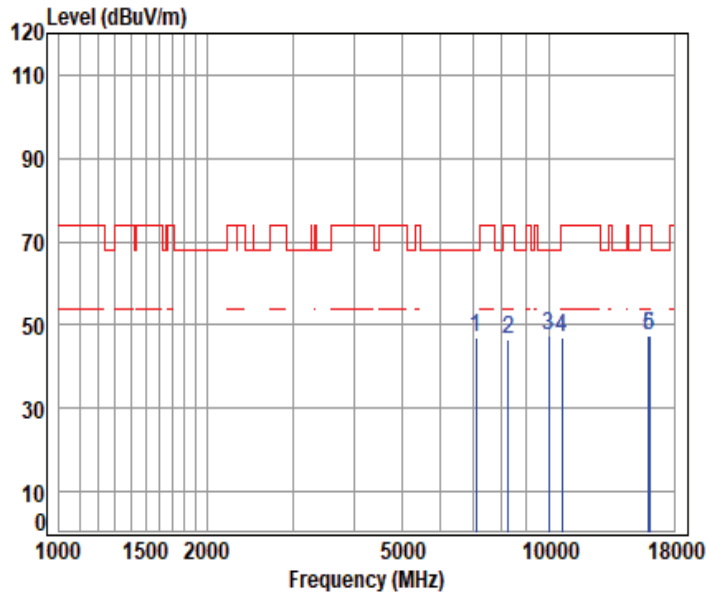

Condition: 3m VERTICAL

Job No : 01607WM

Mode : 5320 TX RSE

: 5G Wi-Fi 11ax20

	Cable	Ant	Preamp	Read	Limit	Over		
Freq	Loss	Factor	Factor	Level	Level	Line	Limit	Remark
MHz	dB	dB/m	dB	dBuV	dBuV/m	dBuV/m	dB	
1	7095.063	11.96	36.39	56.77	55.51	47.09	68.20	-21.11 peak
2	8266.280	11.70	37.83	56.40	53.28	46.41	74.00	-27.59 peak
3	pp 9990.539	12.99	38.90	55.80	51.55	47.64	68.20	-20.56 peak
4	10640.000	13.77	39.34	55.60	49.33	46.84	74.00	-27.16 peak
5	15960.000	17.20	38.64	54.00	45.66	47.50	74.00	-26.50 peak
6	16043.010	17.12	38.56	54.00	45.67	47.35	74.00	-26.65 peak



Unless otherwise agreed in writing, this document is issued by the Company subject to its General Conditions of Service printed overleaf, available on request or accessible at <https://www.sgs.com/en/Terms-and-Conditions>. Attention is drawn to the limitation of liability, indemnification and jurisdiction issues defined therein. Any holder of this document is advised that information contained hereon reflects the Company's findings at the time of its intervention only and within the limits of Client's instructions, if any. The Company's sole responsibility is to its Client and this document does not exonerate parties to a transaction from exercising all their rights and obligations under the transaction documents. This document cannot be reproduced except in full, without prior written approval of the Company. Any unauthorized alteration, forgery or falsification of the content or appearance of this document is unlawful and offenders may be prosecuted to the fullest extent of the law. Unless otherwise stated the results shown in this test report refer only to the sample(s) tested and such sample(s) are retained for 30 days only.

Attention: To check the authenticity of testing /inspection report & certificate, please contact us at telephone: (86-755) 8307 1443, or email: CN.Doccheck@sgs.com
 No.1 Workshop, M-10, Middle Section, Science & Technology Park, Nanshan District, Shenzhen, Guangdong, China 518057 t (86-755) 26012053 f (86-755) 26710594 www.sgsgroup.com.cn
 中国·广东·深圳市南山区科技园中区M-10栋1号厂房 邮编: 518057 t (86-755) 26012053 f (86-755) 26710594 sgs.china@sgs.com

11a_TX_CH_100_Horizontal

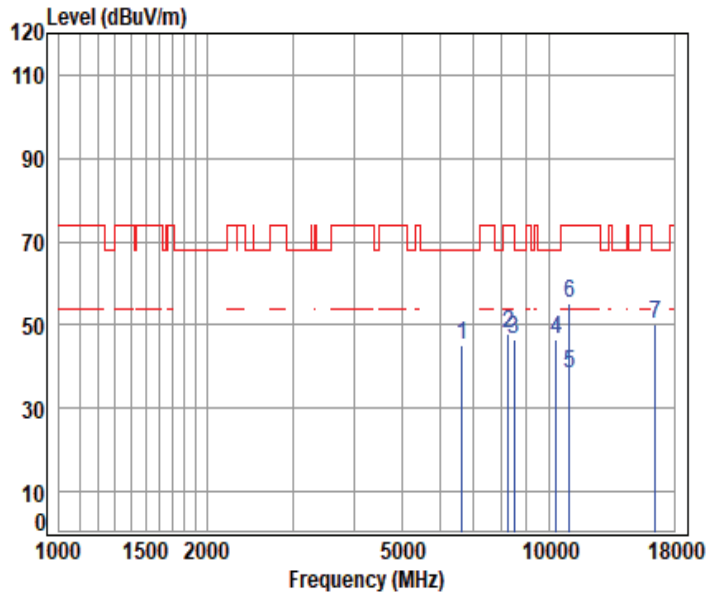

Condition: 3m HORIZONTAL

Job No : 01607WM

Mode : 5500 TX RSE

: 5G Wi-Fi 11a

	Cable	Ant	Preamp	Read	Limit	Over			
Freq	Loss	Factor	Factor	Level	Level	Line	Limit	Remark	
MHz	dB	dB/m	dB	dBuV	dBuV/m	dBuV/m	dB		
1	6647.300	11.51	35.48	56.50	54.78	45.27	68.20	-22.93 peak	
2	8249.458	11.66	37.80	56.40	54.68	47.74	74.00	-26.26 peak	
3	8496.769	12.29	38.31	56.31	52.27	46.56	74.00	-27.44 peak	
4	10353.130	13.60	39.00	55.69	49.63	46.54	68.20	-21.66 peak	
5	pp11000.000	14.17	39.40	55.49	40.41	38.49	54.00	-15.51 Average	
6	11000.000	14.17	39.40	55.49	57.07	55.15	74.00	-18.85 peak	
7	pk16500.000	17.74	38.90	54.05	47.79	50.38	68.20	-17.82 peak	



Unless otherwise agreed in writing, this document is issued by the Company subject to its General Conditions of Service printed overleaf, available on request or accessible at <https://www.sgs.com/en/Terms-and-Conditions>. Attention is drawn to the limitation of liability, indemnification and jurisdiction issues defined therein. Any holder of this document is advised that information contained hereon reflects the Company's findings at the time of its intervention only and within the limits of Client's instructions, if any. The Company's sole responsibility is to its Client and this document does not exonerate parties to a transaction from exercising all their rights and obligations under the transaction documents. This document cannot be reproduced except in full, without prior written approval of the Company. Any unauthorized alteration, forgery or falsification of the content or appearance of this document is unlawful and offenders may be prosecuted to the fullest extent of the law. Unless otherwise stated the results shown in this test report refer only to the sample(s) tested and such sample(s) are retained for 30 days only.

Attention: To check the authenticity of testing /inspection report & certificate, please contact us at telephone: (86-755) 8307 1443, or email: CN.Doccheck@sgs.com
 No.1 Workshop, M-10, Middle Section, Science & Technology Park, Nanshan District, Shenzhen, Guangdong, China 518057 t (86-755) 26012053 f (86-755) 26710594 www.sgsgroup.com.cn
 中国·广东·深圳市南山区科技园中区M-10栋1号厂房 邮编: 518057 t (86-755) 26012053 f (86-755) 26710594 sgs.china@sgs.com

11a_TX_CH_100_Vertical

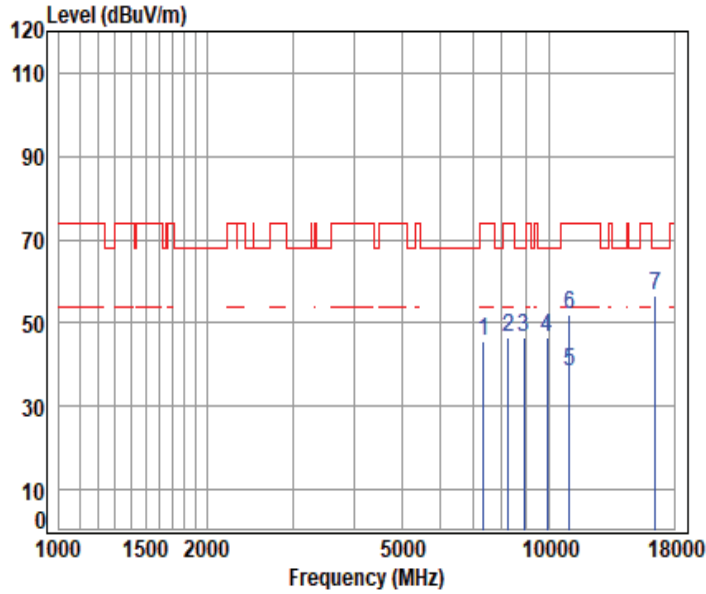

Condition: 3m VERTICAL

Job No : 01607WM

Mode : 5500 TX RSE

: 5G Wi-Fi 11a

	Cable	Ant	Preamp	Read	Limit	Over		
Freq	Loss	Factor	Factor	Level	Level	Line	Limit	Remark
MHz	dB	dB/m	dB	dBuV	dBuV/m	dBuV/m	dB	
1	7352.564	11.50	36.79	56.69	53.95	45.55	74.00	-28.45 peak
2	8249.458	11.66	37.80	56.40	53.39	46.45	74.00	-27.55 peak
3	8904.353	12.22	38.59	56.16	51.96	46.61	68.20	-21.59 peak
4	9929.669	12.86	38.90	55.82	50.60	46.54	68.20	-21.66 peak
5	av11000.000	14.17	39.40	55.49	40.12	38.20	54.00	-15.80 Average
6	11000.000	14.17	39.40	55.49	54.08	52.16	74.00	-21.84 peak
7	pp16500.000	17.74	38.90	54.05	54.19	56.78	68.20	-11.42 peak



Unless otherwise agreed in writing, this document is issued by the Company subject to its General Conditions of Service printed overleaf, available on request or accessible at <https://www.sgs.com/en/Terms-and-Conditions>. Attention is drawn to the limitation of liability, indemnification and jurisdiction issues defined therein. Any holder of this document is advised that information contained hereon reflects the Company's findings at the time of its intervention only and within the limits of Client's instructions, if any. The Company's sole responsibility is to its Client and this document does not exonerate parties to a transaction from exercising all their rights and obligations under the transaction documents. This document cannot be reproduced except in full, without prior written approval of the Company. Any unauthorized alteration, forgery or falsification of the content or appearance of this document is unlawful and offenders may be prosecuted to the fullest extent of the law. Unless otherwise stated the results shown in this test report refer only to the sample(s) tested and such sample(s) are retained for 30 days only.

Attention: To check the authenticity of testing /inspection report & certificate, please contact us at telephone: (86-755) 8307 1443, or email: CN.Doccheck@sgs.com
 No.1 Workshop, M-10, Middle Section, Science & Technology Park, Nanshan District, Shenzhen, Guangdong, China 518057 t (86-755) 26012053 f (86-755) 26710594 www.sgs.com.cn
 中国·广东·深圳市南山区科技园中区M-10栋1号厂房 邮编: 518057 t (86-755) 26012053 f (86-755) 26710594 sgs.china@sgs.com

11a_TX_CH_116_Horizontal

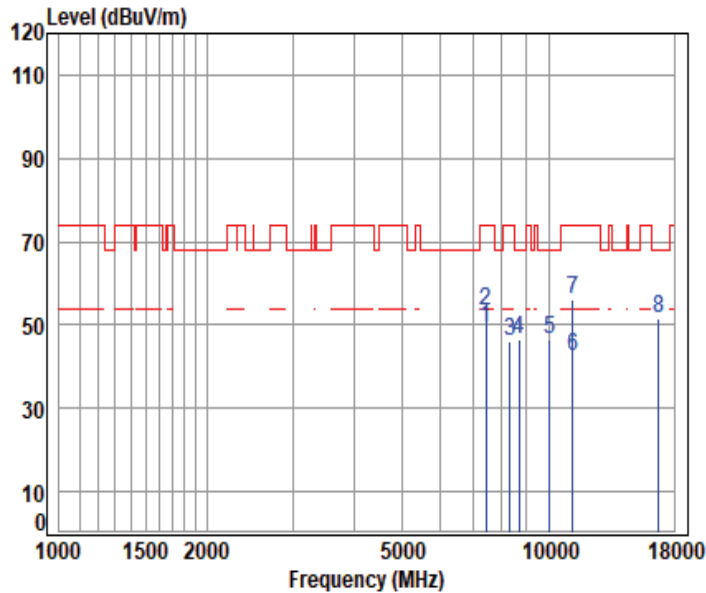

Condition: 3m HORIZONTAL

Job No : 01607WM

Mode : 5580 TX RSE

: 5G Wi-Fi 11a

	Cable	Ant	Preamp	Read	Limit	Over			
Freq	Loss	Factor	Factor	Level	Level	Line	Limit	Remark	
MHz	dB	dB/m	dB	dBuV	dBuV/m	dBuV/m	dB		
1 pp 7442.985	11.38	36.79	56.66	57.56	49.07	54.00	-4.93	Average	
2 7442.985	11.38	36.79	56.66	61.68	53.19	74.00	-20.81	peak	
3 8325.429	11.73	38.31	56.37	52.49	46.16	74.00	-27.84	peak	
4 8671.635	12.05	38.49	56.25	52.33	46.62	68.20	-21.58	peak	
5 10010.910	13.04	38.92	55.80	50.39	46.55	68.20	-21.65	peak	
6 11160.000	14.72	39.56	55.44	43.39	42.23	54.00	-11.77	Average	
7 11160.000	14.72	39.56	55.44	57.41	56.25	74.00	-17.75	peak	
8 pk16740.000	17.54	39.48	54.08	48.63	51.57	68.20	-16.63	peak	



11a_TX_CH_116_Vertical

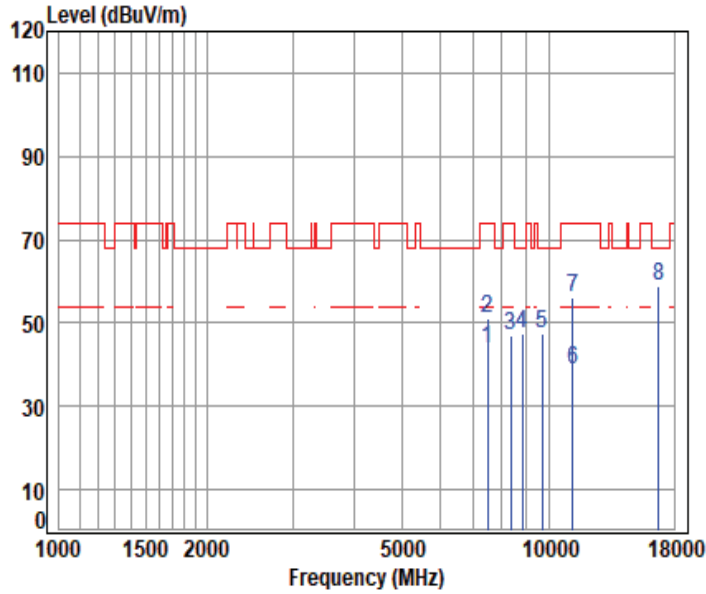

Condition: 3m VERTICAL
 Job No : 01607WM
 Mode : 5580 TX RSE
 : 5G Wi-Fi 11a

	Cable	Ant	Preamp	Read	Limit	Over		
Freq	Loss	Factor	Factor	Level	Level	Line	Limit	Remark
MHz	dB	dB/m	dB	dBuV	dBuV/m	dBuV/m	dB	
1 av 7496.243	11.24	36.80	56.65	52.61	44.00	54.00	-10.00	Average
2 7496.243	11.24	36.80	56.65	59.91	51.30	74.00	-22.70	peak
3 8367.938	11.67	38.66	56.36	52.99	46.96	74.00	-27.04	peak
4 8832.090	12.24	38.50	56.19	52.72	47.27	68.20	-20.93	peak
5 9680.010	12.65	38.70	55.90	52.02	47.47	68.20	-20.73	peak
6 11160.000	14.72	39.56	55.44	40.08	38.92	54.00	-15.08	Average
7 11160.000	14.72	39.56	55.44	57.36	56.20	74.00	-17.80	peak
8 pp16740.000	17.54	39.48	54.08	55.99	58.93	68.20	-9.27	peak



11a_TX_CH_140_Horizontal

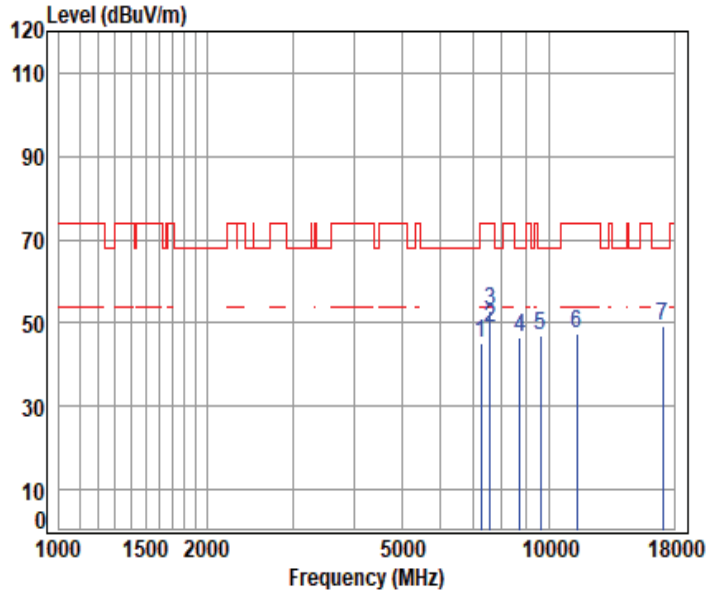

Condition: 3m HORIZONTAL
 Job No : 01607WM
 Mode : 5700 TX RSE
 : 5G Wi-Fi 11a

	Cable	Ant	Preamp	Read	Limit	Over			
Freq	Loss	Factor	Factor	Level	Level	Line	Limit	Remark	
MHz	dB	dB/m	dB	dBuV	dBuV/m	dBuV/m	dB		
1	7278.053	11.51	36.66	56.71	53.87	45.33	74.00	-28.67 peak	
2	pp 7596.164	11.10	36.80	56.62	57.36	48.64	54.00	-5.36 Average	
3	7596.164	11.10	36.80	56.62	61.56	52.84	74.00	-21.16 peak	
4	8707.038	12.10	38.59	56.23	52.22	46.68	68.20	-21.52 peak	
5	9601.452	12.43	38.80	55.93	51.64	46.94	68.20	-21.26 peak	
6	11400.000	14.21	39.70	55.37	48.85	47.39	74.00	-26.61 peak	
7	pk17100.000	18.47	39.80	54.11	45.23	49.39	68.20	-18.81 peak	



Unless otherwise agreed in writing, this document is issued by the Company subject to its General Conditions of Service printed overleaf, available on request or accessible at <https://www.sgs.com/en/Terms-and-Conditions>. Attention is drawn to the limitation of liability, indemnification and jurisdiction issues defined therein. Any holder of this document is advised that information contained hereon reflects the Company's findings at the time of its intervention only and within the limits of Client's instructions, if any. The Company's sole responsibility is to its Client and this document does not exonerate parties to a transaction from exercising all their rights and obligations under the transaction documents. This document cannot be reproduced except in full, without prior written approval of the Company. Any unauthorized alteration, forgery or falsification of the content or appearance of this document is unlawful and offenders may be prosecuted to the fullest extent of the law. Unless otherwise stated the results shown in this test report refer only to the sample(s) tested and such sample(s) are retained for 30 days only.

11a_TX_CH_140_Vertical

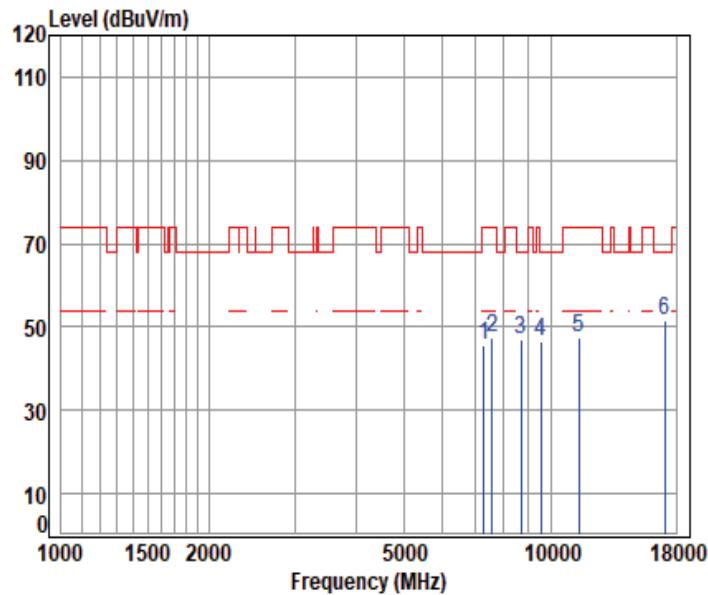

Condition: 3m VERTICAL

Job No : 01607WM

Mode : 5700 TX RSE

: 5G Wi-Fi 11a

	Cable	Ant	Preamp	Read	Limit	Over		
Freq	Loss	Factor	Factor	Level	Level	Line	Limit	Remark
MHz	dB	dB/m	dB	dBuV	dBuV/m	dBuV/m	dB	
1	7300.327	11.51	36.70	56.71	53.94	45.44	74.00	-28.56 peak
2	7596.164	11.10	36.80	56.62	56.18	47.46	74.00	-26.54 peak
3	8680.473	12.06	38.52	56.24	52.72	47.06	68.20	-21.14 peak
4	9542.952	12.50	38.81	55.95	51.24	46.60	68.20	-21.60 peak
5	11400.000	14.21	39.70	55.37	48.99	47.53	74.00	-26.47 peak
6	pp17100.000	18.47	39.80	54.11	47.51	51.67	68.20	-16.53 peak



11ax_20M_TX_CH_100_Horizontal

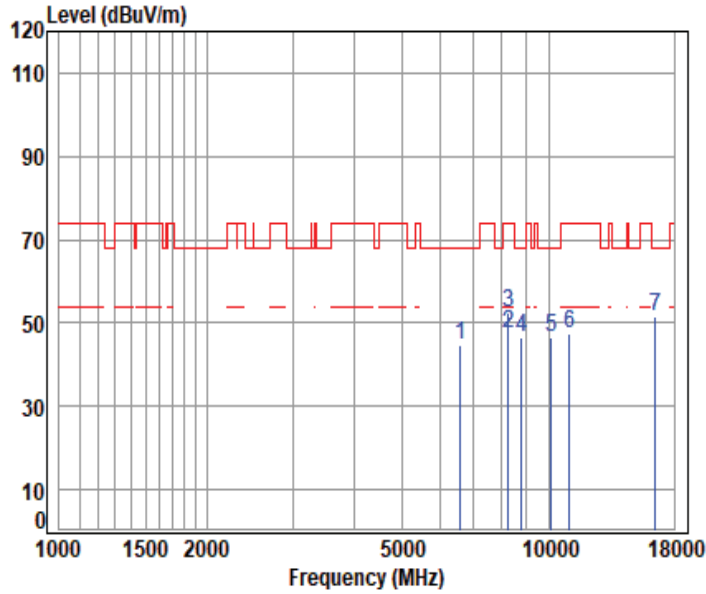

Condition: 3m HORIZONTAL

Job No : 01607WM

Mode : 5500 TX RSE

: 5G Wi-Fi 11ax20

	Cable	Ant	Preamp	Read	Limit	Over			
Freq	Loss	Factor	Factor	Level	Level	Line	Limit	Remark	
MHz	dB	dB/m	dB	dBuV	dBuV/m	dBuV/m	dB		
1	6593.354	11.60	35.17	56.45	54.50	44.82	68.20	-23.38 peak	
2	pp 8249.458	11.66	37.80	56.40	54.29	47.35	54.00	-6.65 Average	
3	8249.458	11.66	37.80	56.40	59.22	52.28	74.00	-21.72 peak	
4	8796.179	12.24	38.50	56.20	52.22	46.76	68.20	-21.44 peak	
5	10103.110	13.26	39.10	55.77	49.97	46.56	68.20	-21.64 peak	
6	11000.000	14.17	39.40	55.49	49.50	47.58	74.00	-26.42 peak	
7	pk16500.000	17.74	38.90	54.05	49.16	51.75	68.20	-16.45 peak	



Unless otherwise agreed in writing, this document is issued by the Company subject to its General Conditions of Service printed overleaf, available on request or accessible at <https://www.sgs.com/en/Terms-and-Conditions>. Attention is drawn to the limitation of liability, indemnification and jurisdiction issues defined therein. Any holder of this document is advised that information contained hereon reflects the Company's findings at the time of its intervention only and within the limits of Client's instructions, if any. The Company's sole responsibility is to its Client and this document does not exonerate parties to a transaction from exercising all their rights and obligations under the transaction documents. This document cannot be reproduced except in full, without prior written approval of the Company. Any unauthorized alteration, forgery or falsification of the content or appearance of this document is unlawful and offenders may be prosecuted to the fullest extent of the law. Unless otherwise stated the results shown in this test report refer only to the sample(s) tested and such sample(s) are retained for 30 days only.

Attention: To check the authenticity of testing /inspection report & certificate, please contact us at telephone: (86-755) 8307 1443, or email: CN.Doccheck@sgs.com
 No.1 Workshop, M-10, Middle Section, Science & Technology Park, Nanshan District, Shenzhen, Guangdong, China 518057 t (86-755) 26012053 f (86-755) 26710594 www.sgs.com.cn
 中国·广东·深圳市南山区科技园中区M-10栋1号厂房 邮编: 518057 t (86-755) 26012053 f (86-755) 26710594 sgs.china@sgs.com

11ax_20M_TX_CH_100_Vercial

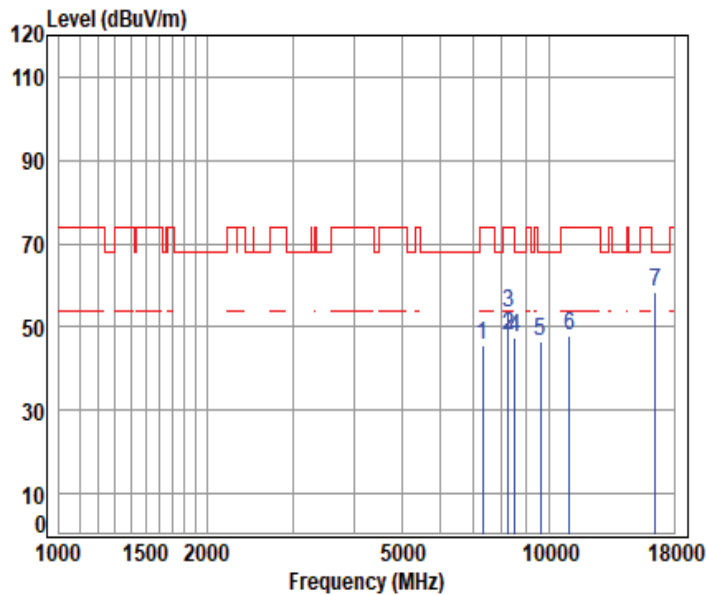

Condition: 3m VERTICAL

Job No : 01607WM

Mode : 5500 TX RSE

: 5G Wi-Fi 11ax20

	Cable	Ant	Preamp	Read	Limit	Over		
Freq	Loss	Factor	Factor	Level	Level	Line	Limit	Remark
MHz	dB	dB/m	dB	dBuV	dBuV/m	dBuV/m	dB	
1	7322.668	11.51	36.75	56.70	54.18	45.74	74.00	-28.26 peak
2	pp 8249.458	11.66	37.80	56.40	54.89	47.95	54.00	-6.05 Average
3	8249.458	11.66	37.80	56.40	60.31	53.37	74.00	-20.63 peak
4	8505.428	12.29	38.30	56.31	53.27	47.55	68.20	-20.65 peak
5	9611.236	12.46	38.78	55.92	51.40	46.72	68.20	-21.48 peak
6	11000.000	14.17	39.40	55.49	49.87	47.95	74.00	-26.05 peak
7	pk16500.000	17.74	38.90	54.05	55.90	58.49	68.20	-9.71 peak



Unless otherwise agreed in writing, this document is issued by the Company subject to its General Conditions of Service printed overleaf, available on request or accessible at <https://www.sgs.com/en/Terms-and-Conditions>. Attention is drawn to the limitation of liability, indemnification and jurisdiction issues defined therein. Any holder of this document is advised that information contained hereon reflects the Company's findings at the time of its intervention only and within the limits of Client's instructions, if any. The Company's sole responsibility is to its Client and this document does not exonerate parties to a transaction from exercising all their rights and obligations under the transaction documents. This document cannot be reproduced except in full, without prior written approval of the Company. Any unauthorized alteration, forgery or falsification of the content or appearance of this document is unlawful and offenders may be prosecuted to the fullest extent of the law. Unless otherwise stated the results shown in this test report refer only to the sample(s) tested and such sample(s) are retained for 30 days only.

Attention: To check the authenticity of testing /inspection report & certificate, please contact us at telephone: (86-755) 8307 1443, or email: CN.Doccheck@sgs.com
 No.1 Workshop, M-10, Middle Section, Science & Technology Park, Nanshan District, Shenzhen, Guangdong, China 518057 t (86-755) 26012053 f (86-755) 26710594 www.sgs.com.cn
 中国·广东·深圳市南山区科技园中区M-10栋1号厂房 邮编: 518057 t (86-755) 26012053 f (86-755) 26710594 sgs.china@sgs.com

11ax_20M_TX_CH_116_Horizontal

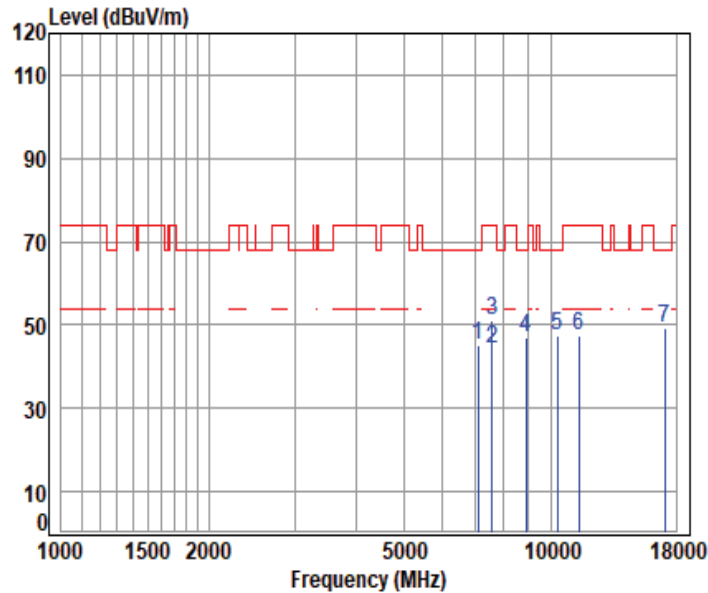

Condition: 3m VERTICAL

Job No : 01607WM

Mode : 5700 TX RSE

: 5G Wi-Fi 11ax20

	Cable Freq	Ant Loss	Preamp Factor	Read Level	Limit Line	Over Limit	Remark
	MHz	dB	dB/m	dBuV	dBuV/m	dBuV/m	dB
1	7109.531	11.95	36.42	56.77	53.36	68.20	-23.24 peak
2 pp	7596.164	11.10	36.80	56.62	52.98	54.00	-9.74 Average
3	7596.164	11.10	36.80	56.62	59.61	74.00	-23.11 peak
4	8904.353	12.22	38.59	56.16	52.29	68.20	-21.26 peak
5	10290.050	13.53	39.01	55.71	50.40	68.20	-20.97 peak
6	11400.000	14.21	39.70	55.37	48.83	74.00	-26.63 peak
7 pk	17100.000	18.47	39.80	54.11	45.30	68.20	-18.74 peak



Unless otherwise agreed in writing, this document is issued by the Company subject to its General Conditions of Service printed overleaf, available on request or accessible at <https://www.sgs.com/en/Terms-and-Conditions>. Attention is drawn to the limitation of liability, indemnification and jurisdiction issues defined therein. Any holder of this document is advised that information contained hereon reflects the Company's findings at the time of its intervention only and within the limits of Client's instructions, if any. The Company's sole responsibility is to its Client and this document does not exonerate parties to a transaction from exercising all their rights and obligations under the transaction documents. This document cannot be reproduced except in full, without prior written approval of the Company. Any unauthorized alteration, forgery or falsification of the content or appearance of this document is unlawful and offenders may be prosecuted to the fullest extent of the law. Unless otherwise stated the results shown in this test report refer only to the sample(s) tested and such sample(s) are retained for 30 days only.

Attention: To check the authenticity of testing /inspection report & certificate, please contact us at telephone: (86-755) 8307 1443, or email: CN.Doccheck@sgs.com
 No.1 Workshop, M-10, Middle Section, Science & Technology Park, Nanshan District, Shenzhen, Guangdong, China 518057 t (86-755) 26012053 f (86-755) 26710594 www.sgsgroup.com.cn
 中国·广东·深圳市南山区科技园中区M-10栋1号厂房 邮编: 518057 t (86-755) 26012053 f (86-755) 26710594 sgs.china@sgs.com

11ax_20M_TX_CH_116_Vercial

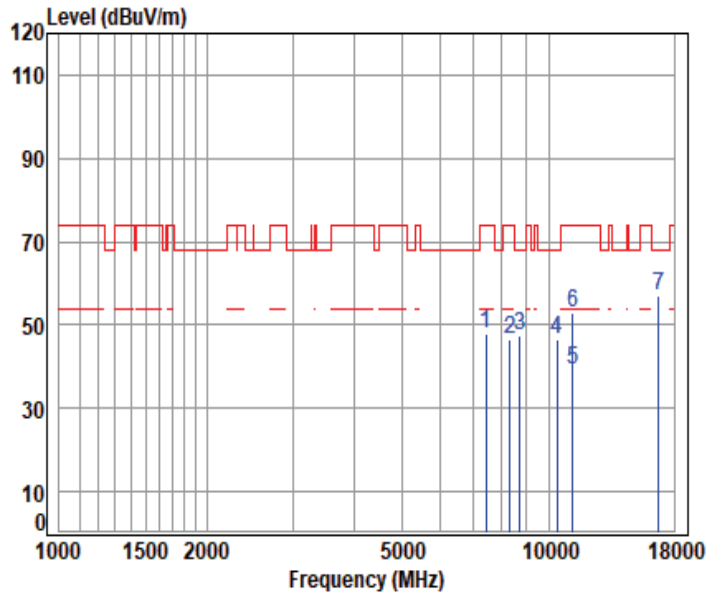

Condition: 3m VERTICAL

Job No : 01607WM

Mode : 5580 TX RSE

: 5G Wi-Fi 11ax20

	Cable Freq	Loss	Ant Factor	Preamp Factor	Read Level	Limit Line	Over Limit	Remark
	MHz	dB	dB/m	dB	dBuV	dBuV/m	dBuV/m	dB
1	7442.985	11.38	36.79	56.66	56.48	47.99	74.00	-26.01 peak
2	8333.913	11.72	38.44	56.37	52.92	46.71	74.00	-27.29 peak
3	8707.038	12.10	38.59	56.23	52.90	47.36	68.20	-20.84 peak
4	10395.390	13.62	39.00	55.67	49.51	46.46	68.20	-21.74 peak
5	av11160.000	14.72	39.56	55.44	40.23	39.07	54.00	-14.93 Average
6	11160.000	14.72	39.56	55.44	54.25	53.09	74.00	-20.91 peak
7	pp16740.000	17.54	39.48	54.08	54.11	57.05	68.20	-11.15 peak



Unless otherwise agreed in writing, this document is issued by the Company subject to its General Conditions of Service printed overleaf, available on request or accessible at <https://www.sgs.com/en/Terms-and-Conditions>. Attention is drawn to the limitation of liability, indemnification and jurisdiction issues defined therein. Any holder of this document is advised that information contained hereon reflects the Company's findings at the time of its intervention only and within the limits of Client's instructions, if any. The Company's sole responsibility is to its Client and this document does not exonerate parties to a transaction from exercising all their rights and obligations under the transaction documents. This document cannot be reproduced except in full, without prior written approval of the Company. Any unauthorized alteration, forgery or falsification of the content or appearance of this document is unlawful and offenders may be prosecuted to the fullest extent of the law. Unless otherwise stated the results shown in this test report refer only to the sample(s) tested and such sample(s) are retained for 30 days only.

Attention: To check the authenticity of testing /inspection report & certificate, please contact us at telephone: (86-755) 8307 1443, or email: CN.Doccheck@sgs.com
 No.1 Workshop, M-10, Middle Section, Science & Technology Park, Nanshan District, Shenzhen, Guangdong, China 518057 t (86-755) 26012053 f (86-755) 26710594 www.sgsgroup.com.cn
 中国·广东·深圳市南山区科技园中区M-10栋1号厂房 邮编: 518057 t (86-755) 26012053 f (86-755) 26710594 sgs.china@sgs.com

11ax_20M_TX_CH_140_Horizontal

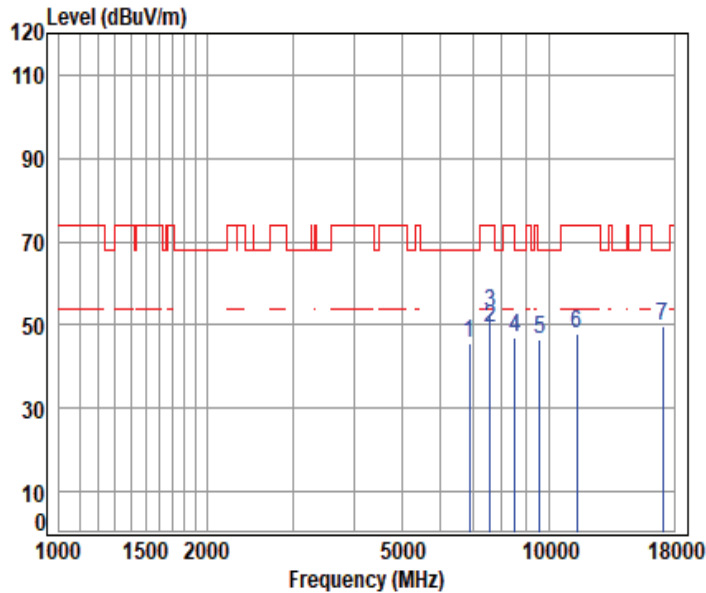

Condition: 3m HORIZONTAL

Job No : 01607WM

Mode : 5700 TX RSE

: 5G Wi-Fi 11ax20

	Cable	Ant	Preamp	Read	Limit	Over			
Freq	Loss	Factor	Factor	Level	Level	Line	Limit	Remark	
MHz	dB	dB/m	dB	dBuV	dBuV/m	dBuV/m	dB		
1	6867.533	11.37	36.07	56.69	54.68	45.43	68.20	-22.77 peak	
2	pp 7596.164	11.10	36.80	56.62	58.21	49.49	54.00	-4.51 Average	
3	7596.164	11.10	36.80	56.62	61.75	53.03	74.00	-20.97 peak	
4	8514.096	12.26	38.30	56.30	52.81	47.07	68.20	-21.13 peak	
5	9562.412	12.48	38.80	55.94	51.01	46.35	68.20	-21.85 peak	
6	11400.000	14.21	39.70	55.37	49.24	47.78	74.00	-26.22 peak	
7	pk17100.000	18.47	39.80	54.11	45.62	49.78	68.20	-18.42 peak	



Unless otherwise agreed in writing, this document is issued by the Company subject to its General Conditions of Service printed overleaf, available on request or accessible at <https://www.sgs.com/en/Terms-and-Conditions>. Attention is drawn to the limitation of liability, indemnification and jurisdiction issues defined therein. Any holder of this document is advised that information contained hereon reflects the Company's findings at the time of its intervention only and within the limits of Client's instructions, if any. The Company's sole responsibility is to its Client and this document does not exonerate parties to a transaction from exercising all their rights and obligations under the transaction documents. This document cannot be reproduced except in full, without prior written approval of the Company. Any unauthorized alteration, forgery or falsification of the content or appearance of this document is unlawful and offenders may be prosecuted to the fullest extent of the law. Unless otherwise stated the results shown in this test report refer only to the sample(s) tested and such sample(s) are retained for 30 days only.

Attention: To check the authenticity of testing /inspection report & certificate, please contact us at telephone: (86-755) 8307 1443, or email: CN.Doccheck@sgs.com
 No.1 Workshop, M-10, Middle Section, Science & Technology Park, Nanshan District, Shenzhen, Guangdong, China 518057 t (86-755) 26012053 f (86-755) 26710594 www.sgsgroup.com.cn
 中国·广东·深圳市南山区科技园中区M-10栋1号厂房 邮编: 518057 t (86-755) 26012053 f (86-755) 26710594 sgs.china@sgs.com

11ax_20M_TX_CH_140_Vercial

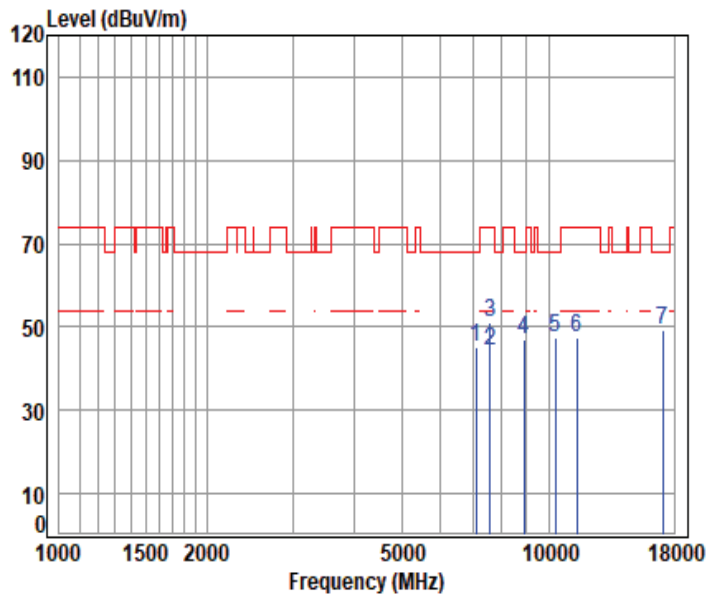

Condition: 3m VERTICAL

Job No : 01607WM

Mode : 5700 TX RSE

: 5G Wi-Fi 11ax20

	Cable	Ant	Preamp	Read	Limit	Over			
Freq	Loss	Factor	Factor	Level	Level	Line	Limit	Remark	
MHz	dB	dB/m	dB	dBuV	dBuV/m	dBuV/m	dB		
1	7109.531	11.95	36.42	56.77	53.36	44.96	68.20	-23.24 peak	
2	pp 7596.164	11.10	36.80	56.62	52.98	44.26	54.00	-9.74 Average	
3	7596.164	11.10	36.80	56.62	59.61	50.89	74.00	-23.11 peak	
4	8904.353	12.22	38.59	56.16	52.29	46.94	68.20	-21.26 peak	
5	10290.050	13.53	39.01	55.71	50.40	47.23	68.20	-20.97 peak	
6	11400.000	14.21	39.70	55.37	48.83	47.37	74.00	-26.63 peak	
7	pk17100.000	18.47	39.80	54.11	45.30	49.46	68.20	-18.74 peak	



Unless otherwise agreed in writing, this document is issued by the Company subject to its General Conditions of Service printed overleaf, available on request or accessible at <https://www.sgs.com/en/Terms-and-Conditions>. Attention is drawn to the limitation of liability, indemnification and jurisdiction issues defined therein. Any holder of this document is advised that information contained hereon reflects the Company's findings at the time of its intervention only and within the limits of Client's instructions, if any. The Company's sole responsibility is to its Client and this document does not exonerate parties to a transaction from exercising all their rights and obligations under the transaction documents. This document cannot be reproduced except in full, without prior written approval of the Company. Any unauthorized alteration, forgery or falsification of the content or appearance of this document is unlawful and offenders may be prosecuted to the fullest extent of the law. Unless otherwise stated the results shown in this test report refer only to the sample(s) tested and such sample(s) are retained for 30 days only.

Attention: To check the authenticity of testing /inspection report & certificate, please contact us at telephone: (86-755) 8307 1443, or email: CN.Doccheck@sgs.com
 No.1 Workshop, M-10, Middle Section, Science & Technology Park, Nanshan District, Shenzhen, Guangdong, China 518057 t (86-755) 26012053 f (86-755) 26710594 www.sgs.com.cn
 中国·广东·深圳市南山区科技园中区M-10栋1号厂房 邮编: 518057 t (86-755) 26012053 f (86-755) 26710594 sgs.china@sgs.com

11a_TX_CH_149_Horizontal

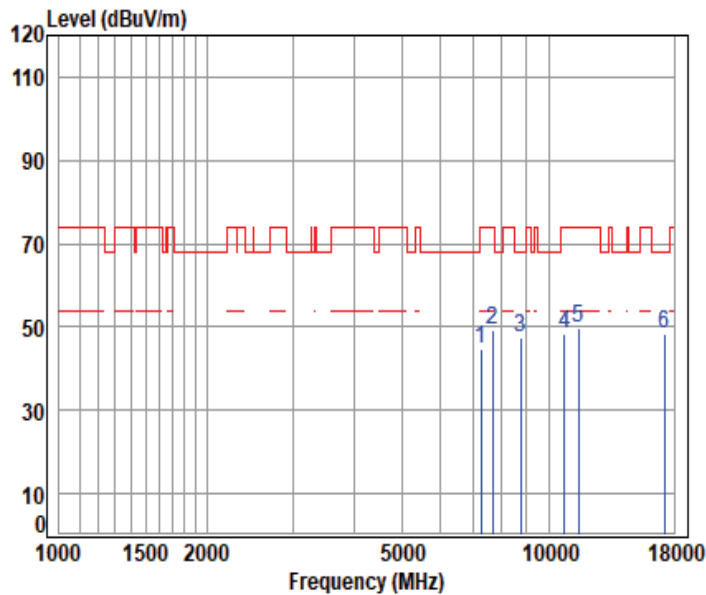

Condition: 3m HORIZONTAL

Job No : 01607WM

Mode : 5745 TX RSE

: 5.8G Wi-Fi 11a

	Cable	Ant	Preamp	Read	Limit	Over		
Freq	Loss	Factor	Factor	Level	Level	Line	Limit	Remark
MHz	dB	dB/m	dB	dBuV	dBuV/m	dBuV/m	dB	
1	7270.644	11.51	36.64	56.48	52.93	44.60	74.00	-29.40 peak
2	7658.314	11.30	36.90	56.17	57.15	49.18	74.00	-24.82 peak
3	8742.585	12.16	38.51	55.23	52.10	47.54	68.20	-20.66 peak
4	10772.670	13.78	39.33	53.64	48.97	48.44	74.00	-25.56 peak
5	11490.000	14.97	39.61	53.65	48.69	49.62	74.00	-24.38 peak
6	pp17235.000	17.83	40.01	54.35	44.83	48.32	68.20	-19.88 peak



Unless otherwise agreed in writing, this document is issued by the Company subject to its General Conditions of Service printed overleaf, available on request or accessible at <https://www.sgs.com/en/Terms-and-Conditions>. Attention is drawn to the limitation of liability, indemnification and jurisdiction issues defined therein. Any holder of this document is advised that information contained hereon reflects the Company's findings at the time of its intervention only and within the limits of Client's instructions, if any. The Company's sole responsibility is to its Client and this document does not exonerate parties to a transaction from exercising all their rights and obligations under the transaction documents. This document cannot be reproduced except in full, without prior written approval of the Company. Any unauthorized alteration, forgery or falsification of the content or appearance of this document is unlawful and offenders may be prosecuted to the fullest extent of the law. Unless otherwise stated the results shown in this test report refer only to the sample(s) tested and such sample(s) are retained for 30 days only.

Attention: To check the authenticity of testing /inspection report & certificate, please contact us at telephone: (86-755) 8307 1443, or email: CN.Doccheck@sgs.com

11a_TX_CH_149_Vertical

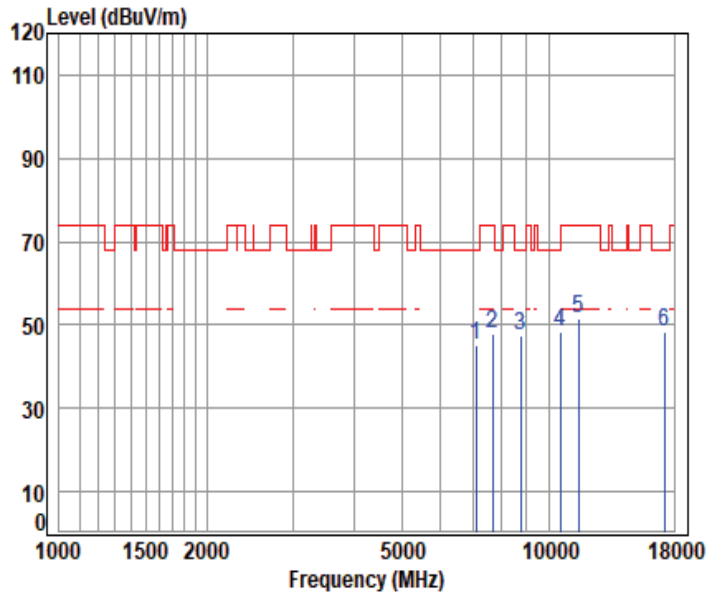

Condition: 3m VERTICAL

Job No : 01607WM

Mode : 5745 TX RSE

: 5.8G Wi-Fi 11a

	Cable	Ant	Preamp	Read	Limit	Over			
Freq	Loss	Factor	Factor	Level	Level	Line	Limit	Remark	
MHz	dB	dB/m	dB	dBuV	dBuV/m	dBuV/m	dB		
1	7109.531	11.95	36.42	56.61	53.56	45.32	68.20	-22.88 peak	
2	7658.314	11.30	36.90	56.17	55.94	47.97	74.00	-26.03 peak	
3	8760.413	12.19	38.50	55.22	51.97	47.44	68.20	-20.76 peak	
4	10533.960	13.62	39.17	53.78	49.37	48.38	68.20	-19.82 peak	
5	11490.000	14.97	39.61	53.65	50.52	51.45	74.00	-22.55 peak	
6	pp17235.000	17.83	40.01	54.35	44.94	48.43	68.20	-19.77 peak	



Unless otherwise agreed in writing, this document is issued by the Company subject to its General Conditions of Service printed overleaf, available on request or accessible at <https://www.sgs.com/en/Terms-and-Conditions>. Attention is drawn to the limitation of liability, indemnification and jurisdiction issues defined therein. Any holder of this document is advised that information contained hereon reflects the Company's findings at the time of its intervention only and within the limits of Client's instructions, if any. The Company's sole responsibility is to its Client and this document does not exonerate parties to a transaction from exercising all their rights and obligations under the transaction documents. This document cannot be reproduced except in full, without prior written approval of the Company. Any unauthorized alteration, forgery or falsification of the content or appearance of this document is unlawful and offenders may be prosecuted to the fullest extent of the law. Unless otherwise stated the results shown in this test report refer only to the sample(s) tested and such sample(s) are retained for 30 days only.

Attention: To check the authenticity of testing /inspection report & certificate, please contact us at telephone: (86-755) 8307 1443, or email: CN.Doccheck@sgs.com
 No.1 Workshop, M-10, Middle Section, Science & Technology Park, Nanshan District, Shenzhen, Guangdong, China 518057 t (86-755) 26012053 f (86-755) 26710594 www.sgs.com.cn
 中国·广东·深圳市南山区科技园中区M-10栋1号厂房 邮编: 518057 t (86-755) 26012053 f (86-755) 26710594 sgs.china@sgs.com

11a_TX_CH_157_Horizontal

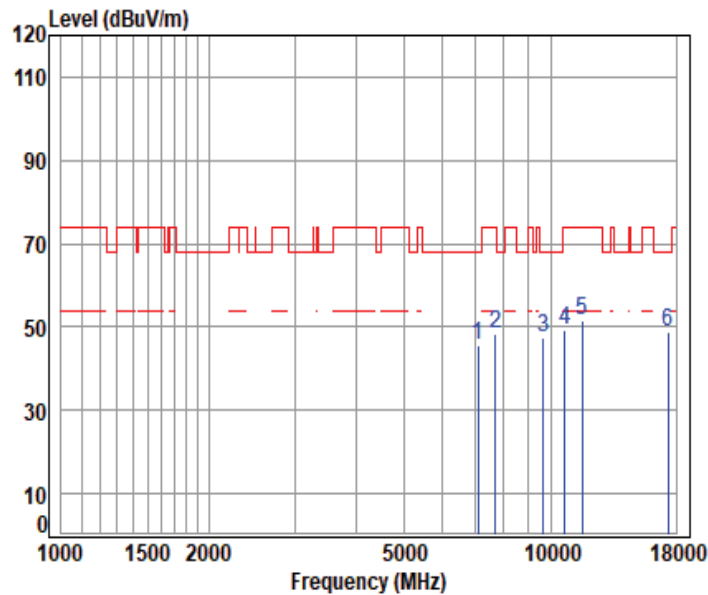

Condition: 3m HORIZONTAL

Job No : 01607WM

Mode : 5785 TX RSE

: 5.8G Wi-Fi 11a

	Cable	Ant	Preamp	Read	Limit	Over			
Freq	Loss	Factor	Factor	Level	Level	Line	Limit	Remark	
MHz	dB	dB/m	dB	dBuV	dBuV/m	dBuV/m	dB		
1	7102.293	11.98	36.40	56.62	53.71	45.47	68.20	-22.73 peak	
2	7713.113	11.43	36.93	56.13	56.17	48.40	74.00	-25.60 peak	
3	9630.836	12.51	38.74	54.43	50.63	47.45	68.20	-20.75 peak	
4	10674.370	13.92	39.37	53.70	49.58	49.17	74.00	-24.83 peak	
5	11570.000	14.78	39.60	53.67	50.83	51.54	74.00	-22.46 peak	
6	pp17355.000	18.00	40.31	54.37	44.98	48.92	68.20	-19.28 peak	



Unless otherwise agreed in writing, this document is issued by the Company subject to its General Conditions of Service printed overleaf, available on request or accessible at <https://www.sgs.com/en/Terms-and-Conditions>. Attention is drawn to the limitation of liability, indemnification and jurisdiction issues defined therein. Any holder of this document is advised that information contained hereon reflects the Company's findings at the time of its intervention only and within the limits of Client's instructions, if any. The Company's sole responsibility is to its Client and this document does not exonerate parties to a transaction from exercising all their rights and obligations under the transaction documents. This document cannot be reproduced except in full, without prior written approval of the Company. Any unauthorized alteration, forgery or falsification of the content or appearance of this document is unlawful and offenders may be prosecuted to the fullest extent of the law. Unless otherwise stated the results shown in this test report refer only to the sample(s) tested and such sample(s) are retained for 30 days only.

Attention: To check the authenticity of testing /inspection report & certificate, please contact us at telephone: (86-755) 8307 1443, or email: CN.Doccheck@sgs.com
 No.1 Workshop, M-10, Middle Section, Science & Technology Park, Nanshan District, Shenzhen, Guangdong, China 518057 t (86-755) 26012053 f (86-755) 26710594 www.sgs.com.cn
 中国·广东·深圳市南山区科技园中区M-10栋1号厂房 邮编: 518057 t (86-755) 26012053 f (86-755) 26710594 sgs.china@sgs.com

11a_TX_CH_157_Vertical

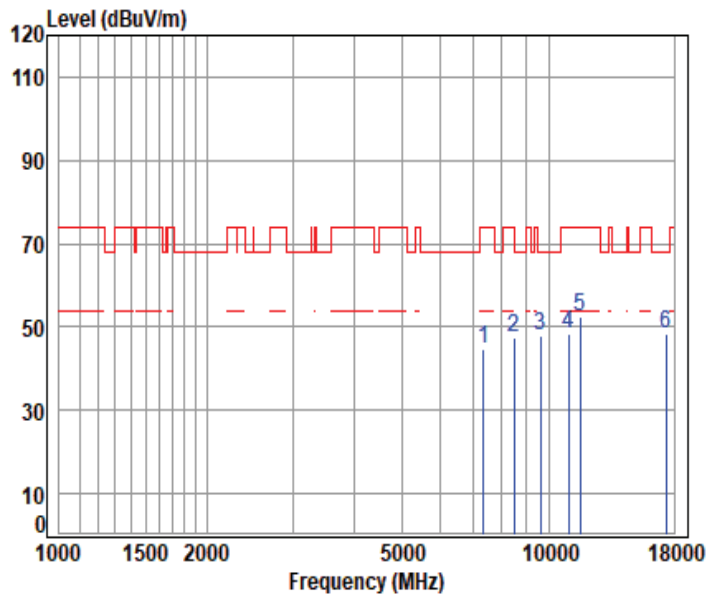

Condition: 3m VERTICAL

Job No : 01607WM

Mode : 5785 TX RSE

: 5.8G Wi-Fi 11a

	Cable	Ant	Preamp	Read	Limit	Over			
Freq	Loss	Factor	Factor	Level	Level	Line	Limit	Remark	
MHz	dB	dB/m	dB	dBuV	dBuV/m	dBuV/m	dB		
1	7345.079	11.51	36.79	56.42	52.82	44.70	74.00	-29.30 peak	
2	8488.119	12.23	38.32	55.46	52.52	47.61	74.00	-26.39 peak	
3	9611.236	12.46	38.78	54.45	51.08	47.87	68.20	-20.33 peak	
4	10960.830	14.09	39.36	53.52	48.57	48.50	74.00	-25.50 peak	
5	11570.000	14.78	39.60	53.67	51.71	52.42	74.00	-21.58 peak	
6	pp17355.000	18.00	40.31	54.37	44.65	48.59	68.20	-19.61 peak	



Unless otherwise agreed in writing, this document is issued by the Company subject to its General Conditions of Service printed overleaf, available on request or accessible at <https://www.sgs.com/en/Terms-and-Conditions>. Attention is drawn to the limitation of liability, indemnification and jurisdiction issues defined therein. Any holder of this document is advised that information contained hereon reflects the Company's findings at the time of its intervention only and within the limits of Client's instructions, if any. The Company's sole responsibility is to its Client and this document does not exonerate parties to a transaction from exercising all their rights and obligations under the transaction documents. This document cannot be reproduced except in full, without prior written approval of the Company. Any unauthorized alteration, forgery or falsification of the content or appearance of this document is unlawful and offenders may be prosecuted to the fullest extent of the law. Unless otherwise stated the results shown in this test report refer only to the sample(s) tested and such sample(s) are retained for 30 days only.

Attention: To check the authenticity of testing /inspection report & certificate, please contact us at telephone: (86-755) 8307 1443, or email: CN.Doccheck@sgs.com
 No.1 Workshop, M-10, Middle Section, Science & Technology Park, Nanshan District, Shenzhen, Guangdong, China 518057 t (86-755) 26012053 f (86-755) 26710594 www.sgs.com.cn
 中国·广东·深圳市南山区科技园中区M-10栋1号厂房 邮编: 518057 t (86-755) 26012053 f (86-755) 26710594 sgs.china@sgs.com

11a_TX_CH_165_Horizontal

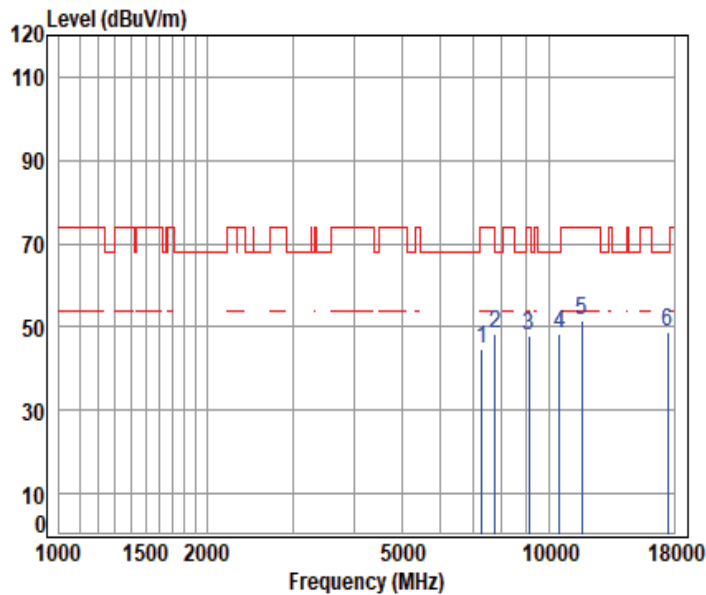

Condition: 3m HORIZONTAL

Job No : 01607WM

Mode : 5825 TX RSE

: 5.8G Wi-Fi 11a

	Cable	Ant	Preamp	Read	Limit	Over			
Freq	Loss	Factor	Factor	Level	Level	Line	Limit	Remark	
MHz	dB	dB/m	dB	dBuV	dBuV/m	dBuV/m	dB		
1	7285.470	11.51	36.67	56.47	53.18	44.89	74.00	-29.11 peak	
2	7768.304	11.35	37.07	56.09	56.24	48.57	68.20	-19.63 peak	
3	9096.867	12.12	38.60	54.91	52.03	47.84	74.00	-26.16 peak	
4	10523.230	13.63	39.15	53.79	49.27	48.26	68.20	-19.94 peak	
5	11650.000	14.69	39.55	53.69	51.13	51.68	74.00	-22.32 peak	
6	pp17475.000	18.35	40.78	54.40	44.04	48.77	68.20	-19.43 peak	



Unless otherwise agreed in writing, this document is issued by the Company subject to its General Conditions of Service printed overleaf, available on request or accessible at <https://www.sgs.com/en/Terms-and-Conditions>. Attention is drawn to the limitation of liability, indemnification and jurisdiction issues defined therein. Any holder of this document is advised that information contained hereon reflects the Company's findings at the time of its intervention only and within the limits of Client's instructions, if any. The Company's sole responsibility is to its Client and this document does not exonerate parties to a transaction from exercising all their rights and obligations under the transaction documents. This document cannot be reproduced except in full, without prior written approval of the Company. Any unauthorized alteration, forgery or falsification of the content or appearance of this document is unlawful and offenders may be prosecuted to the fullest extent of the law. Unless otherwise stated the results shown in this test report refer only to the sample(s) tested and such sample(s) are retained for 30 days only.

Attention: To check the authenticity of testing /inspection report & certificate, please contact us at telephone: (86-755) 8307 1443, or email: CN.Doccheck@sgs.com
 No.1 Workshop, M-10, Middle Section, Science & Technology Park, Nanshan District, Shenzhen, Guangdong, China 518057 t (86-755) 26012053 f (86-755) 26710594 www.sgs.com.cn
 中国·广东·深圳市南山区科技园中区M-10栋1号厂房 邮编: 518057 t (86-755) 26012053 f (86-755) 26710594 sgs.china@sgs.com

11a_TX_CH_165_Verical

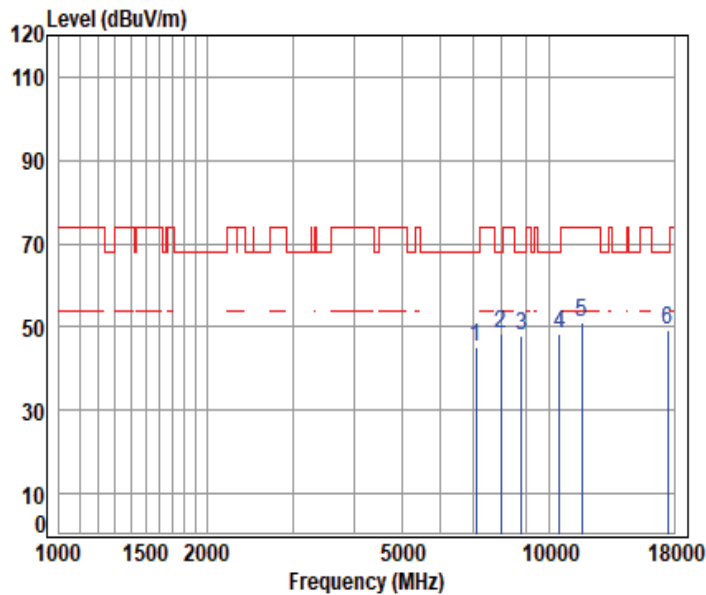

Condition: 3m VERTICAL

Job No : 01607WM

Mode : 5825 TX RSE

: 5.8G Wi-Fi 11a

	Cable	Ant	Preamp	Read	Limit	Over			
Freq	Loss	Factor	Factor	Level	Level	Line	Limit	Remark	
MHz	dB	dB/m	dB	dBuV	dBuV/m	dBuV/m	dB		
1	7109.531	11.95	36.42	56.61	53.26	45.02	68.20	-23.18 peak	
2	7976.779	11.56	37.75	55.92	54.80	48.19	68.20	-20.01 peak	
3	8778.277	12.22	38.50	55.20	52.55	48.07	68.20	-20.13 peak	
4	10501.820	13.64	39.10	53.80	49.41	48.35	68.20	-19.85 peak	
5	11650.000	14.69	39.55	53.69	50.45	51.00	74.00	-23.00 peak	
6	pp17475.000	18.35	40.78	54.40	44.62	49.35	68.20	-18.85 peak	



11ax_20M_TX_CH_149_Horizontal

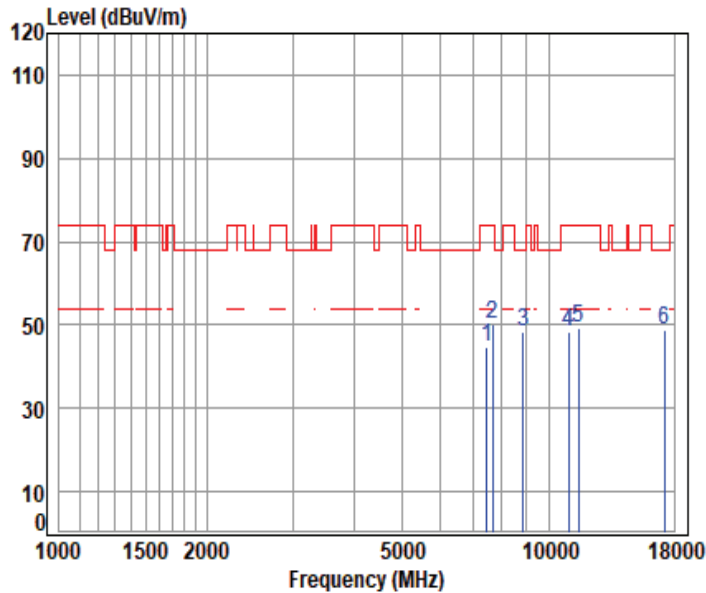

Condition: 3m HORIZONTAL

Job No : 01607WM

Mode : 5745 TX RSE

: 5.8G Wi-Fi 11ax20

	Cable	Ant	Preamp	Read	Limit	Over		
Freq	Loss	Factor	Factor	Level	Level	Line	Limit	Remark
MHz	dB	dB/m	dB	dBuV	dBuV/m	dBuV/m	dB	
1	7458.163	11.34	36.80	56.33	52.99	44.80	74.00	-29.20 peak
2	7658.314	11.30	36.90	56.17	58.07	50.10	74.00	-23.90 peak
3	8850.100	12.23	38.50	55.13	52.70	48.30	68.20	-19.90 peak
4	10983.190	14.13	39.38	53.51	48.58	48.58	74.00	-25.42 peak
5	11490.000	14.97	39.61	53.65	48.30	49.23	74.00	-24.77 peak
6	pp17235.000	17.83	40.01	54.35	45.53	49.02	68.20	-19.18 peak



Unless otherwise agreed in writing, this document is issued by the Company subject to its General Conditions of Service printed overleaf, available on request or accessible at <https://www.sgs.com/en/Terms-and-Conditions>. Attention is drawn to the limitation of liability, indemnification and jurisdiction issues defined therein. Any holder of this document is advised that information contained hereon reflects the Company's findings at the time of its intervention only and within the limits of Client's instructions, if any. The Company's sole responsibility is to its Client and this document does not exonerate parties to a transaction from exercising all their rights and obligations under the transaction documents. This document cannot be reproduced except in full, without prior written approval of the Company. Any unauthorized alteration, forgery or falsification of the content or appearance of this document is unlawful and offenders may be prosecuted to the fullest extent of the law. Unless otherwise stated the results shown in this test report refer only to the sample(s) tested and such sample(s) are retained for 30 days only.

Attention: To check the authenticity of testing /inspection report & certificate, please contact us at telephone: (86-755) 8307 1443, or email: CN.Doccheck@sgs.com
 No.1 Workshop, M-10, Middle Section, Science & Technology Park, Nanshan District, Shenzhen, Guangdong, China 518057 t (86-755) 26012053 f (86-755) 26710594 www.sgsgroup.com.cn
 中国·广东·深圳市南山区科技园中区M-10栋1号厂房 邮编: 518057 t (86-755) 26012053 f (86-755) 26710594 sgs.china@sgs.com

11ax_20M_TX_CH_149_Vertical

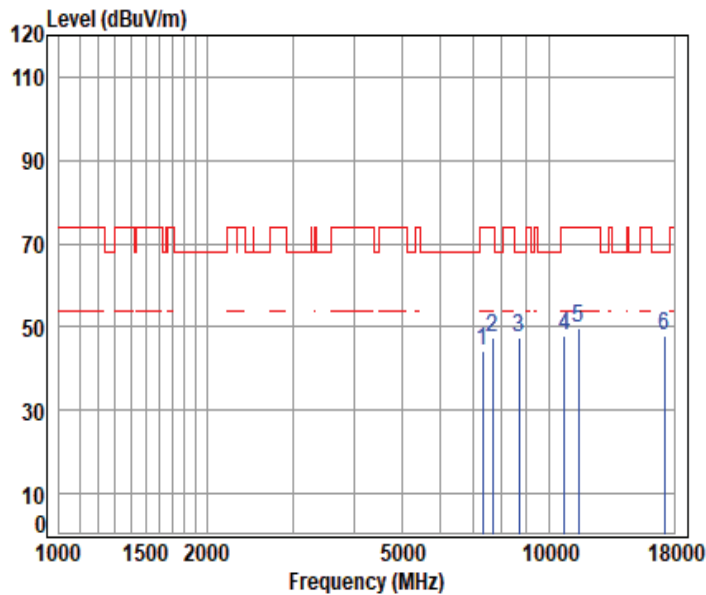

Condition: 3m VERTICAL

Job No : 01607WM

Mode : 5745 TX RSE

: 5.8G Wi-Fi 11ax20

	Cable	Ant	Preamp	Read	Limit	Over		
Freq	Loss	Factor	Factor	Level	Level	Line	Limit	Remark
MHz	dB	dB/m	dB	dBuV	dBuV/m	dBuV/m	dB	
1	7330.131	11.51	36.76	56.44	52.52	44.35	74.00	-29.65 peak
2	7658.314	11.30	36.90	56.17	55.42	47.45	74.00	-26.55 peak
3	8698.174	12.09	38.59	55.27	51.90	47.31	68.20	-20.89 peak
4	10761.710	13.82	39.34	53.64	48.52	48.04	74.00	-25.96 peak
5	11490.000	14.97	39.61	53.65	49.02	49.95	74.00	-24.05 peak
6	pp17235.000	17.83	40.01	54.35	44.21	47.70	68.20	-20.50 peak



Unless otherwise agreed in writing, this document is issued by the Company subject to its General Conditions of Service printed overleaf, available on request or accessible at <https://www.sgs.com/en/Terms-and-Conditions>. Attention is drawn to the limitation of liability, indemnification and jurisdiction issues defined therein. Any holder of this document is advised that information contained hereon reflects the Company's findings at the time of its intervention only and within the limits of Client's instructions, if any. The Company's sole responsibility is to its Client and this document does not exonerate parties to a transaction from exercising all their rights and obligations under the transaction documents. This document cannot be reproduced except in full, without prior written approval of the Company. Any unauthorized alteration, forgery or falsification of the content or appearance of this document is unlawful and offenders may be prosecuted to the fullest extent of the law. Unless otherwise stated the results shown in this test report refer only to the sample(s) tested and such sample(s) are retained for 30 days only.

Attention: To check the authenticity of testing /inspection report & certificate, please contact us at telephone: (86-755) 8307 1443, or email: CN.Doccheck@sgs.com
 No.1 Workshop, M-10, Middle Section, Science & Technology Park, Nanshan District, Shenzhen, Guangdong, China 518057 t (86-755) 26012053 f (86-755) 26710594 www.sgs.com.cn
 中国·广东·深圳市南山区科技园中区M-10栋1号厂房 邮编: 518057 t (86-755) 26012053 f (86-755) 26710594 sgs.china@sgs.com

11ax_20M_TX_CH_157_Horizontal

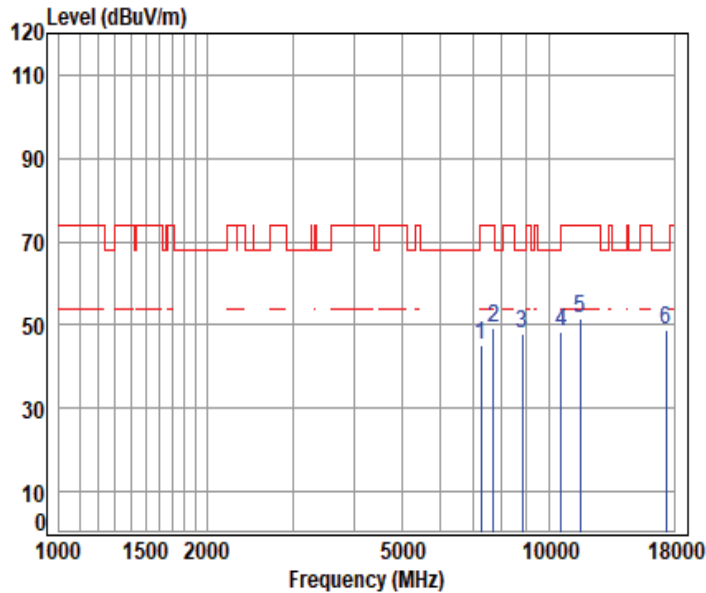

Condition: 3m HORIZONTAL

Job No : 01607WM

Mode : 5785 TX RSE

: 5.8G Wi-Fi 11ax20

	Cable	Ant	Preamp	Read	Limit	Over			
Freq	Loss	Factor	Factor	Level	Level	Line	Limit	Remark	
MHz	dB	dB/m	dB	dBuV	dBuV/m	dBuV/m	dB		
1	7270.644	11.51	36.64	56.48	53.28	44.95	74.00	-29.05 peak	
2	7713.113	11.43	36.93	56.13	56.89	49.12	74.00	-24.88 peak	
3	8814.115	12.25	38.50	55.17	52.23	47.81	68.20	-20.39 peak	
4	10598.530	13.59	39.30	53.74	49.26	48.41	68.20	-19.79 peak	
5	11570.000	14.78	39.60	53.67	50.89	51.60	74.00	-22.40 peak	
6	pp17355.000	18.00	40.31	54.37	44.93	48.87	68.20	-19.33 peak	



Unless otherwise agreed in writing, this document is issued by the Company subject to its General Conditions of Service printed overleaf, available on request or accessible at <https://www.sgs.com/en/Terms-and-Conditions>. Attention is drawn to the limitation of liability, indemnification and jurisdiction issues defined therein. Any holder of this document is advised that information contained hereon reflects the Company's findings at the time of its intervention only and within the limits of Client's instructions, if any. The Company's sole responsibility is to its Client and this document does not exonerate parties to a transaction from exercising all their rights and obligations under the transaction documents. This document cannot be reproduced except in full, without prior written approval of the Company. Any unauthorized alteration, forgery or falsification of the content or appearance of this document is unlawful and offenders may be prosecuted to the fullest extent of the law. Unless otherwise stated the results shown in this test report refer only to the sample(s) tested and such sample(s) are retained for 30 days only.

Attention: To check the authenticity of testing /inspection report & certificate, please contact us at telephone: (86-755) 8307 1443, or email: CN.Doccheck@sgs.com
 No.1 Workshop, M-10, Middle Section, Science & Technology Park, Nanshan District, Shenzhen, Guangdong, China 518057 t (86-755) 26012053 f (86-755) 26710594 www.sgs.com.cn
 中国·广东·深圳市南山区科技园中区M-10栋1号厂房 邮编: 518057 t (86-755) 26012053 f (86-755) 26710594 sgs.china@sgs.com

11ax_20M_TX_CH_157_Vertical

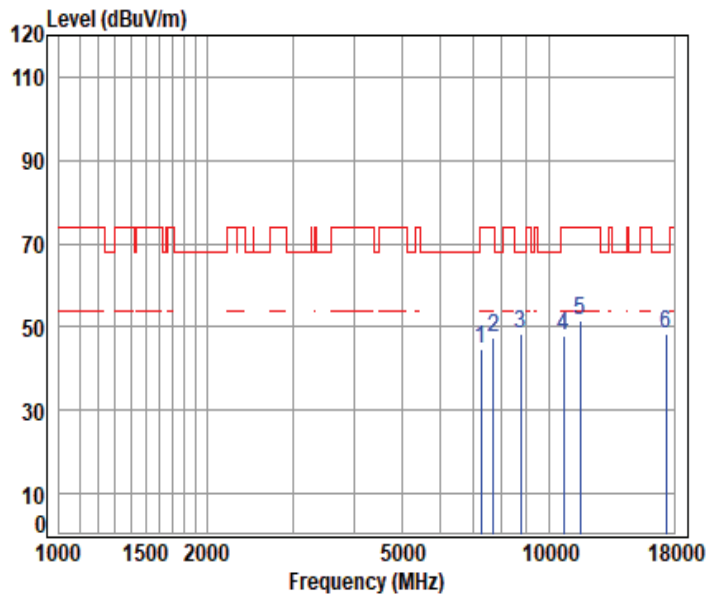

Condition: 3m VERTICAL

Job No : 01607WM

Mode : 5785 TX RSE

: 5.8G Wi-Fi 11ax20

	Cable	Ant	Preamp	Read	Limit	Over			
Freq	Loss	Factor	Factor	Level	Level	Line	Limit	Remark	
MHz	dB	dB/m	dB	dBuV	dBuV/m	dBuV/m	dB		
1	7278.053	11.51	36.66	56.48	53.23	44.92	74.00	-29.08 peak	
2	7713.113	11.43	36.93	56.13	55.24	47.47	74.00	-26.53 peak	
3	8760.413	12.19	38.50	55.22	52.70	48.17	68.20	-20.03 peak	
4	10717.950	13.98	39.38	53.67	48.42	48.11	74.00	-25.89 peak	
5	11570.000	14.78	39.60	53.67	50.87	51.58	74.00	-22.42 peak	
6	pp17355.000	18.00	40.31	54.37	44.60	48.54	68.20	-19.66 peak	



Unless otherwise agreed in writing, this document is issued by the Company subject to its General Conditions of Service printed overleaf, available on request or accessible at <https://www.sgs.com/en/Terms-and-Conditions>. Attention is drawn to the limitation of liability, indemnification and jurisdiction issues defined therein. Any holder of this document is advised that information contained hereon reflects the Company's findings at the time of its intervention only and within the limits of Client's instructions, if any. The Company's sole responsibility is to its Client and this document does not exonerate parties to a transaction from exercising all their rights and obligations under the transaction documents. This document cannot be reproduced except in full, without prior written approval of the Company. Any unauthorized alteration, forgery or falsification of the content or appearance of this document is unlawful and offenders may be prosecuted to the fullest extent of the law. Unless otherwise stated the results shown in this test report refer only to the sample(s) tested and such sample(s) are retained for 30 days only.

Attention: To check the authenticity of testing /inspection report & certificate, please contact us at telephone: (86-755) 8307 1443, or email: CN.Doccheck@sgs.com
 No.1 Workshop, M-10, Middle Section, Science & Technology Park, Nanshan District, Shenzhen, Guangdong, China 518057 t (86-755) 26012053 f (86-755) 26710594 www.sgs.com.cn
 中国·广东·深圳市南山区科技园中区M-10栋1号厂房 邮编: 518057 t (86-755) 26012053 f (86-755) 26710594 sgs.china@sgs.com

11ax_20M_TX_CH_165_Horizontal

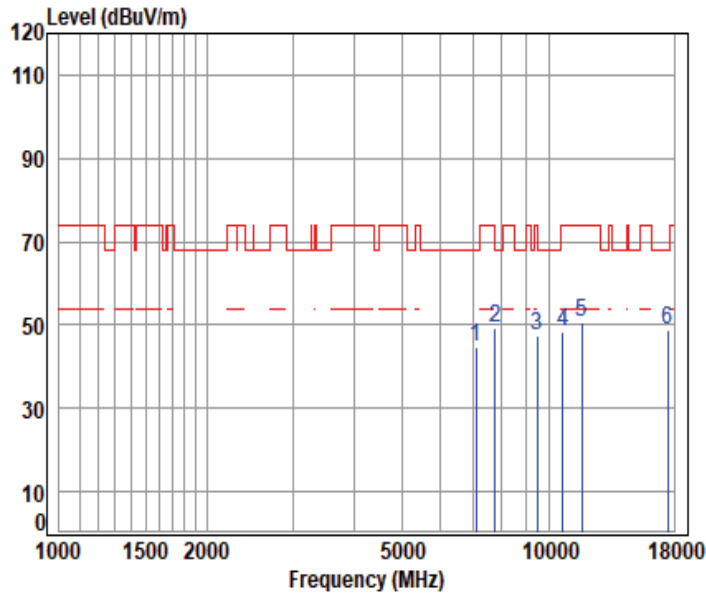

Condition: 3m HORIZONTAL

Job No : 01607WM

Mode : 5825 TX RSE

: 5.8G Wi-Fi 11ax20

	Cable Freq	Loss	Ant Factor	Preamp Factor	Read Level	Limit Level	Over Limit	Remark
	MHz	dB	dB/m	dB	dBuV	dBuV/m	dBuV/m	dB
1	7102.293	11.98	36.40	56.62	52.94	44.70	68.20	-23.50 peak
2	pp 7768.304	11.35	37.07	56.09	57.00	49.33	68.20	-18.87 peak
3	9446.244	12.42	38.80	54.60	50.85	47.47	74.00	-26.53 peak
4	10663.500	13.88	39.36	53.70	48.93	48.47	74.00	-25.53 peak
5	11650.000	14.69	39.55	53.69	50.23	50.78	74.00	-23.22 peak
6	17475.000	18.35	40.78	54.40	43.97	48.70	68.20	-19.50 peak



Unless otherwise agreed in writing, this document is issued by the Company subject to its General Conditions of Service printed overleaf, available on request or accessible at <https://www.sgs.com/en/Terms-and-Conditions>. Attention is drawn to the limitation of liability, indemnification and jurisdiction issues defined therein. Any holder of this document is advised that information contained hereon reflects the Company's findings at the time of its intervention only and within the limits of Client's instructions, if any. The Company's sole responsibility is to its Client and this document does not exonerate parties to a transaction from exercising all their rights and obligations under the transaction documents. This document cannot be reproduced except in full, without prior written approval of the Company. Any unauthorized alteration, forgery or falsification of the content or appearance of this document is unlawful and offenders may be prosecuted to the fullest extent of the law. Unless otherwise stated the results shown in this test report refer only to the sample(s) tested and such sample(s) are retained for 30 days only.

Attention: To check the authenticity of testing /inspection report & certificate, please contact us at telephone: (86-755) 8307 1443, or email: CN.Doccheck@sgs.com
 No.1 Workshop, M-10, Middle Section, Science & Technology Park, Nanshan District, Shenzhen, Guangdong, China 518057 t (86-755) 26012053 f (86-755) 26710594 www.sgs.com.cn
 中国·广东·深圳市南山区科技园中区M-10栋1号厂房 邮编: 518057 t (86-755) 26012053 f (86-755) 26710594 sgs.china@sgs.com

11ax_20M_TX_CH_165_Vercial

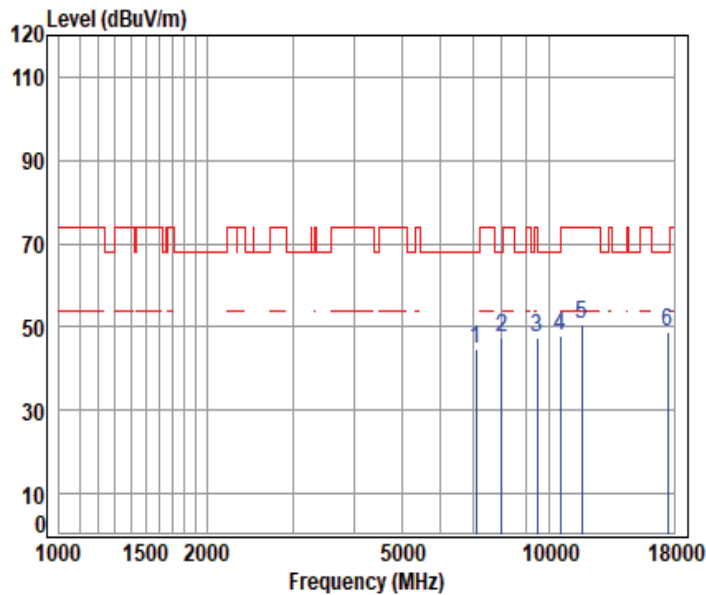

Condition: 3m VERTICAL

Job No : 01607WM

Mode : 5825 TX RSE

: 5.8G Wi-Fi 11ax20

	Cable	Ant	Preamp	Read	Limit	Over			
Freq	Loss	Factor	Factor	Level	Level	Line	Limit	Remark	
MHz	dB	dB/m	dB	dBuV	dBuV/m	dBuV/m	dB		
1	7095.063	11.96	36.39	56.62	53.17	44.90	68.20	-23.30 peak	
2	7993.045	11.56	37.79	55.91	53.80	47.24	68.20	-20.96 peak	
3	9446.244	12.42	38.80	54.60	50.63	47.25	74.00	-26.75 peak	
4	10533.960	13.62	39.17	53.78	49.05	48.06	68.20	-20.14 peak	
5	11650.000	14.69	39.55	53.69	50.01	50.56	74.00	-23.44 peak	
6	pp17475.000	18.35	40.78	54.40	43.87	48.60	68.20	-19.60 peak	



Unless otherwise agreed in writing, this document is issued by the Company subject to its General Conditions of Service printed overleaf, available on request or accessible at <https://www.sgs.com/en/Terms-and-Conditions>. Attention is drawn to the limitation of liability, indemnification and jurisdiction issues defined therein. Any holder of this document is advised that information contained hereon reflects the Company's findings at the time of its intervention only and within the limits of Client's instructions, if any. The Company's sole responsibility is to its Client and this document does not exonerate parties to a transaction from exercising all their rights and obligations under the transaction documents. This document cannot be reproduced except in full, without prior written approval of the Company. Any unauthorized alteration, forgery or falsification of the content or appearance of this document is unlawful and offenders may be prosecuted to the fullest extent of the law. Unless otherwise stated the results shown in this test report refer only to the sample(s) tested and such sample(s) are retained for 30 days only.

Attention: To check the authenticity of testing /inspection report & certificate, please contact us at telephone: (86-755) 8307 1443, or email: CN.Doccheck@sgs.com
 No.1 Workshop, M-10, Middle Section, Science & Technology Park, Nanshan District, Shenzhen, Guangdong, China 518057 t (86-755) 26012053 f (86-755) 26710594 www.sgs.com.cn
 中国·广东·深圳市南山区科技园中区M-10栋1号厂房 邮编: 518057 t (86-755) 26012053 f (86-755) 26710594 sgs.china@sgs.com

7.5 Radiated Emissions which fall in the restricted bands

Test Requirement 47 CFR Part 15, Subpart C 15.209 & Subpart E 15.407(b)

Test Method: ANSI C63.10 (2013) Section 6.10.5

Measurement Distance: 3m

Limit:

Frequency(MHz)	Field strength(microvolts/meter)	Measurement distance(meters)
0.009-0.490	2400/F(kHz)	300
0.490-1.705	24000/F(kHz)	30
1.705-30.0	30	30
30-88	100	3
88-216	150	3
216-960	200	3
Above 960	500	3

*(1) For transmitters operating in the 5.15-5.25 GHz band: All emissions outside of the 5.15-5.35 GHz band shall not exceed an e.i.r.p. of -27 dBm/MHz.

(2) For transmitters operating in the 5.25-5.35 GHz band: All emissions outside of the 5.15-5.35 GHz band shall not exceed an e.i.r.p. of -27 dBm/MHz.

(3) For transmitters operating in the 5.47-5.725 GHz band: All emissions outside of the 5.47-5.725 GHz band shall not exceed an e.i.r.p. of -27 dBm/MHz.

(4) For transmitters operating in the 5.725-5.85 GHz band:

(i) All emissions shall be limited to a level of -27 dBm/MHz at 75 MHz or more above or below the band edge increasing linearly to 10 dBm/MHz at 25 MHz above or below the band edge, and from 25 MHz above or below the band edge increasing linearly to a level of 15.6 dBm/MHz at 5 MHz above or below the band edge, and from 5 MHz above or below the band edge increasing linearly to a level of 27 dBm/MHz at the band edge.

Remark: The emission limits shown in the above table are based on measurements employing a CISPR quasi-peak detector except for the frequency bands 9-90kHz, 110-490kHz and above 1000 MHz. Radiated emission limits in these three bands are based on measurements employing an average detector, the peak field strength of any emission shall not exceed the maximum permitted average limits specified above by more than 20 dB under any condition of modulation.

7.5.1 E.U.T. Operation

Operating Environment:

Temperature: 24.5 °C Humidity: 50.9 % RH Atmospheric Pressure: 1020 mbar



Unless otherwise agreed in writing, this document is issued by the Company subject to its General Conditions of Service printed overleaf, available on request or accessible at <https://www.sgs.com/en/Terms-and-Conditions>. Attention is drawn to the limitation of liability, indemnification and jurisdiction issues defined therein. Any holder of this document is advised that information contained hereon reflects the Company's findings at the time of its intervention only and within the limits of Client's instructions, if any. The Company's sole responsibility is to its Client and this document does not exonerate parties to a transaction from exercising all their rights and obligations under the transaction documents. This document cannot be reproduced except in full, without prior written approval of the Company. Any unauthorized alteration, forgery or falsification of the content or appearance of this document is unlawful and offenders may be prosecuted to the fullest extent of the law. Unless otherwise stated the results shown in this test report refer only to the sample(s) tested and such sample(s) are retained for 30 days only.

Attention: To check the authenticity of testing /inspection report & certificate, please contact us at telephone: (86-755) 8307 1443, or email: CN.Doccheck@sgs.com
 No.1 Workshop, M-10, Middle Section, Science & Technology Park, Nanshan District, Shenzhen, Guangdong, China 518057 t (86-755) 26012053 f (86-755) 26710594 www.sgs.com.cn
 中国·广东·深圳市南山区科技园中区M-10栋1号厂房 邮编: 518057 t (86-755) 26012053 f (86-755) 26710594 sgs.china@sgs.com

7.5.2 Test Mode Description

Pre-scan / Final test	Mode Code	Description
Final test	14	Charge + TX mode (U-NII-1) _Keep the EUT in continuously transmitting mode with all modulation types and being charged. All data rates for each modulation type have been tested, Only the data of worst case is recorded in the report.
Final test	15	Charge + TX mode (U-NII-2A) _Keep the EUT in continuously transmitting mode with all modulation types and being charged. All data rates for each modulation type have been tested, Only the data of worst case is recorded in the report.
Final test	16	Charge + TX mode (U-NII-2C) _Keep the EUT in continuously transmitting mode with all modulation types and being charged. All data rates for each modulation type have been tested, Only the data of worst case is recorded in the report.
Final test	17	Charge + TX mode (U-NII-3) _Keep the EUT in continuously transmitting mode with all modulation types and being charged. All data rates for each modulation type have been tested, Only the data of worst case is recorded in the report.

7.5.3 Test Setup Diagram

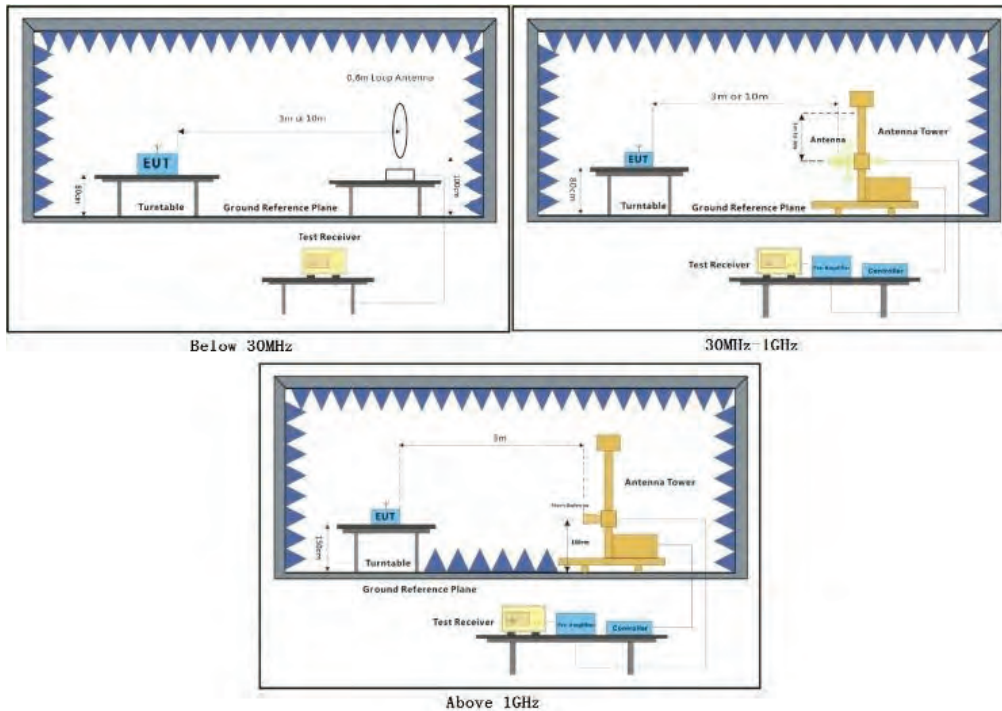

Unless otherwise agreed in writing, this document is issued by the Company subject to its General Conditions of Service printed overleaf, available on request or accessible at <https://www.sgs.com/en/Terms-and-Conditions>. Attention is drawn to the limitation of liability, indemnification and jurisdiction issues defined therein. Any holder of this document is advised that information contained hereon reflects the Company's findings at the time of its intervention only and within the limits of Client's instructions, if any. The Company's sole responsibility is to its Client and this document does not exonerate parties to a transaction from exercising all their rights and obligations under the transaction documents. This document cannot be reproduced except in full, without prior written approval of the Company. Any unauthorized alteration, forgery or falsification of the content or appearance of this document is unlawful and offenders may be prosecuted to the fullest extent of the law. Unless otherwise stated the results shown in this test report refer only to the sample(s) tested and such sample(s) are retained for 30 days only.

Attention: To check the authenticity of testing /inspection report & certificate, please contact us at telephone: (86-755) 8307 1443, or email: CN.Doccheck@sgs.com

No.1 Workshop, M-10, Middle Section, Science & Technology Park, Nanshan District, Shenzhen, Guangdong, China 518057 t (86-755) 26012053 f (86-755) 26710594 www.sgs.com.cn
 中国·广东·深圳市南山区科技园中区M-10栋1号厂房 邮编: 518057 t (86-755) 26012053 f (86-755) 26710594 sgs.china@sgs.com

7.5.4 Measurement Procedure and Data

- a. For below 1GHz, the EUT was placed on the top of a rotating table 0.8 meters above the ground at a 3 or 10 meter semi-anechoic chamber. The table was rotated 360 degrees to determine the position of the highest radiation.
- b. For above 1GHz, the EUT was placed on the top of a rotating table 1.5 meters above the ground at a 3 meter fully-anechoic chamber. The table was rotated 360 degrees to determine the position of the highest radiation.
- c. The EUT was set 3 or 10 meters away from the interference-receiving antenna, which was mounted on the top of a variable-height antenna tower.
- d. The antenna height is varied from one meter to four meters above the ground to determine the maximum value of the field strength. Both horizontal and vertical polarizations of the antenna are set to make the measurement.
- e. For each suspected emission, the EUT was arranged to its worst case and then the antenna was tuned to heights from 1 meter to 4 meters (for the test frequency of below 30MHz, the antenna was tuned to heights 1 meter) and the rotatable table was turned from 0 degrees to 360 degrees to find the maximum reading.
- f. The test-receiver system was set to Peak Detect Function and Specified Bandwidth with Maximum Hold Mode.
- g. If the emission level of the EUT in peak mode was 10dB lower than the limit specified, then testing could be stopped and the peak values of the EUT would be reported. Otherwise the emissions that did not have 10dB margin would be re-tested one by one using peak, quasi-peak or average method as specified and then reported in a data sheet.
- h. Test the EUT in the lowest channel, the middle channel, the Highest channel.
- i. The radiation measurements are performed in X, Y, Z axis positioning for Transmitting mode, and found the X axis positioning which it is the worst case.
- j. Repeat above procedures until all frequencies measured was complete.

Remark 1: Level= Read Level+ Cable Loss+ Antenna Factor- Preamp Factor

Remark 2. The resolution bandwidth of test receiver/spectrum analyzer is 1MHz and the video bandwidth is 3MHz for Peak detection (PK) and Average detection (AV) at frequency above 1GHz.

Remark 3. For fundamental and harmonic signal measurement, the resolution bandwidth of test receiver/spectrum analyzer is 1MHz and the video bandwidth is $\geq 1/T$ (Duty cycle < 98%) or 10Hz (Duty cycle $\geq 98\%$) for Average detection (AV) at frequency above 1GHz.



11a_TX_CH_36_Horizontal-Peak

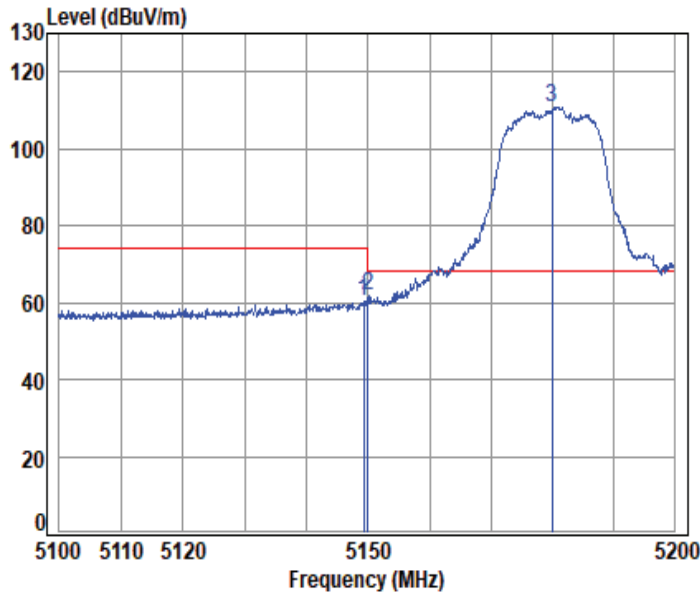

Condition: 3m HORIZONTAL

Job No : 01607WM

Mode : 5180 Band edge

: 5G Wi-Fi 11a

	Cable	Ant	Preamp	Read	Limit	Over			
Freq	Loss	Factor	Factor	Level	Level	Line	Limit	Remark	
MHz	dB	dB/m	dB	dBuV	dBuV/m	dBuV/m	dB		
1	5149.257	10.14	32.40	30.55	48.17	60.16	74.00	-13.84	peak
2	5149.980	10.14	32.40	30.55	49.73	61.72	74.00	-12.28	peak
3	pp 5180.000	10.25	32.46	30.56	98.72	110.87	68.20	42.67	peak



Unless otherwise agreed in writing, this document is issued by the Company subject to its General Conditions of Service printed overleaf, available on request or accessible at <https://www.sgs.com/en/Terms-and-Conditions>. Attention is drawn to the limitation of liability, indemnification and jurisdiction issues defined therein. Any holder of this document is advised that information contained hereon reflects the Company's findings at the time of its intervention only and within the limits of Client's instructions, if any. The Company's sole responsibility is to its Client and this document does not exonerate parties to a transaction from exercising all their rights and obligations under the transaction documents. This document cannot be reproduced except in full, without prior written approval of the Company. Any unauthorized alteration, forgery or falsification of the content or appearance of this document is unlawful and offenders may be prosecuted to the fullest extent of the law. Unless otherwise stated the results shown in this test report refer only to the sample(s) tested and such sample(s) are retained for 30 days only.

11a_TX_CH_36_Horizontal-Avg

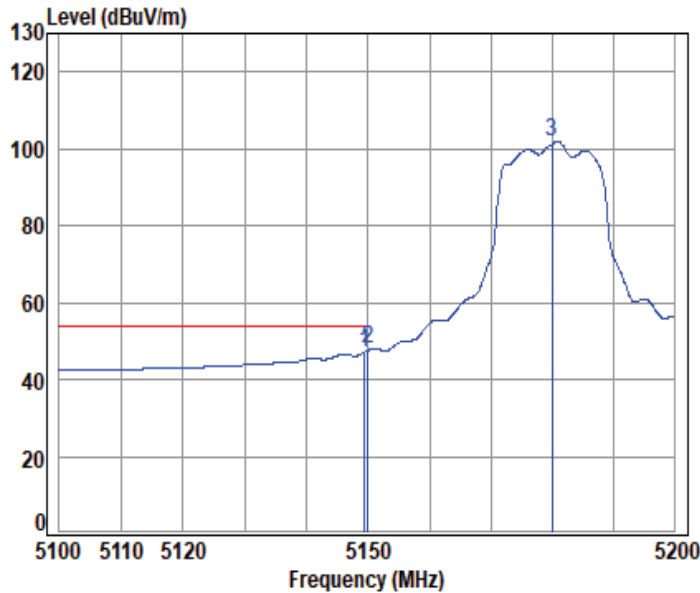

Condition: 3m HORIZONTAL

Job No : 01607WM

Mode : 5180 Band edge

: 5G Wi-Fi 11a

	Cable	Ant	Preamp	Read	Limit	Over			
Freq	Loss	Factor	Factor	Level	Level	Line	Limit	Remark	
MHz	dB	dB/m	dB	dBuV	dBuV/m	dBuV/m	dB		
1	5149.458	10.14	32.40	30.55	35.21	47.20	54.00	-6.80	Average
2	pp 5149.980	10.14	32.40	30.55	35.82	47.81	54.00	-6.19	Average
3	5180.000	10.25	32.46	30.56	89.85	102.00	-----	-----	Average



Unless otherwise agreed in writing, this document is issued by the Company subject to its General Conditions of Service printed overleaf, available on request or accessible at <https://www.sgs.com/en/Terms-and-Conditions>. Attention is drawn to the limitation of liability, indemnification and jurisdiction issues defined therein. Any holder of this document is advised that information contained hereon reflects the Company's findings at the time of its intervention only and within the limits of Client's instructions, if any. The Company's sole responsibility is to its Client and this document does not exonerate parties to a transaction from exercising all their rights and obligations under the transaction documents. This document cannot be reproduced except in full, without prior written approval of the Company. Any unauthorized alteration, forgery or falsification of the content or appearance of this document is unlawful and offenders may be prosecuted to the fullest extent of the law. Unless otherwise stated the results shown in this test report refer only to the sample(s) tested and such sample(s) are retained for 30 days only.

11a_TX_CH_36_Verical-Peak

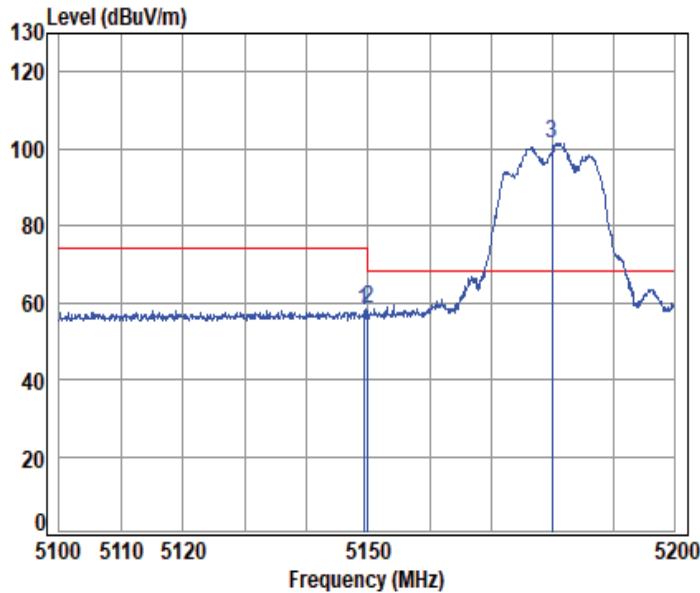

Condition: 3m VERTICAL

Job No : 01607WM

Mode : 5180 Band edge

: 5G Wi-Fi 11a

	Cable	Ant	Preamp	Read	Limit	Over			
Freq	Loss	Factor	Factor	Level	Level	Line	Limit	Remark	
MHz	dB	dB/m	dB	dBuV	dBuV/m	dBuV/m	dB		
1	5149.257	10.14	32.40	30.55	46.08	58.07	74.00	-15.93	peak
2	5149.980	10.14	32.40	30.55	46.21	58.20	74.00	-15.80	peak
3	pp 5180.000	10.25	32.46	30.56	89.14	101.29	68.20	33.09	peak



Unless otherwise agreed in writing, this document is issued by the Company subject to its General Conditions of Service printed overleaf, available on request or accessible at <https://www.sgs.com/en/Terms-and-Conditions>. Attention is drawn to the limitation of liability, indemnification and jurisdiction issues defined therein. Any holder of this document is advised that information contained hereon reflects the Company's findings at the time of its intervention only and within the limits of Client's instructions, if any. The Company's sole responsibility is to its Client and this document does not exonerate parties to a transaction from exercising all their rights and obligations under the transaction documents. This document cannot be reproduced except in full, without prior written approval of the Company. Any unauthorized alteration, forgery or falsification of the content or appearance of this document is unlawful and offenders may be prosecuted to the fullest extent of the law. Unless otherwise stated the results shown in this test report refer only to the sample(s) tested and such sample(s) are retained for 30 days only.

11a_TX_CH_36_Vercial-Avg

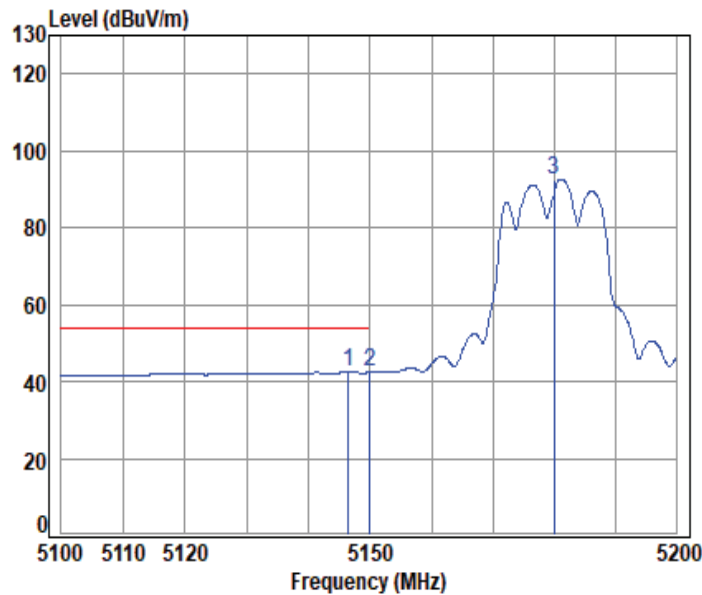

Condition: 3m VERTICAL

Job No : 01607WM

Mode : 5180 Band edge

: 5G Wi-Fi 11a

	Cable	Ant	Preamp	Read	Limit	Over			
Freq	Loss	Factor	Factor	Level	Level	Line	Limit	Remark	
MHz	dB	dB/m	dB	dBuV	dBuV/m	dBuV/m	dB		
1	5146.458	10.13	32.39	30.55	30.46	42.43	54.00	-11.57	Average
2	pp 5149.980	10.14	32.40	30.55	30.50	42.49	54.00	-11.51	Average
3	5180.000	10.25	32.46	30.56	80.43	92.58	-----	-----	Average



Unless otherwise agreed in writing, this document is issued by the Company subject to its General Conditions of Service printed overleaf, available on request or accessible at <https://www.sgs.com/en/Terms-and-Conditions>. Attention is drawn to the limitation of liability, indemnification and jurisdiction issues defined therein. Any holder of this document is advised that information contained hereon reflects the Company's findings at the time of its intervention only and within the limits of Client's instructions, if any. The Company's sole responsibility is to its Client and this document does not exonerate parties to a transaction from exercising all their rights and obligations under the transaction documents. This document cannot be reproduced except in full, without prior written approval of the Company. Any unauthorized alteration, forgery or falsification of the content or appearance of this document is unlawful and offenders may be prosecuted to the fullest extent of the law. Unless otherwise stated the results shown in this test report refer only to the sample(s) tested and such sample(s) are retained for 30 days only.

Attention: To check the authenticity of testing /inspection report & certificate, please contact us at telephone: (86-755) 8307 1443, or email: CN.Doccheck@sgs.com
 No.1 Workshop, M-10, Middle Section, Science & Technology Park, Nanshan District, Shenzhen, Guangdong, China 518057 t (86-755) 26012053 f (86-755) 26710594 www.sgs.com.cn
 中国·广东·深圳市南山区科技园中区M-10栋1号厂房 邮编: 518057 t (86-755) 26012053 f (86-755) 26710594 sgs.china@sgs.com

11ac_VHT(20M)_TX_CH_36_Horizontal-Peak

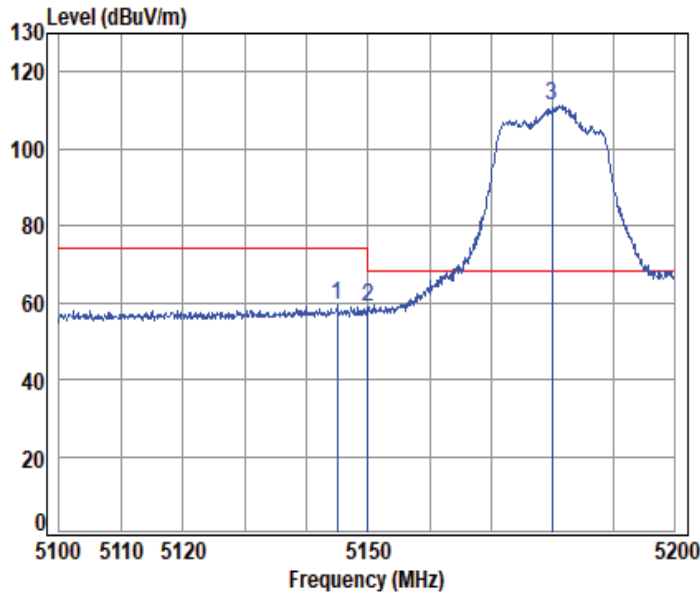

Condition: 3m HORIZONTAL

Job No : 01607WM

Mode : 5180 Band edge

: 5G Wi-Fi 11ac20

	Cable	Ant	Preamp	Read	Limit	Over			
Freq	Loss	Factor	Factor	Level	Level	Line	Limit	Remark	
MHz	dB	dB/m	dB	dBuV	dBuV/m	dBuV/m	dB		
1	5144.959	10.12	32.39	30.55	47.51	59.47	74.00	-14.53 peak	
2	5149.980	10.14	32.40	30.55	46.92	58.91	74.00	-15.09 peak	
3	pp 5180.000	10.25	32.46	30.56	99.05	111.20	68.20	43.00 peak	



11ac_VHT(20M)_TX_CH_36_Horizontal-Avg

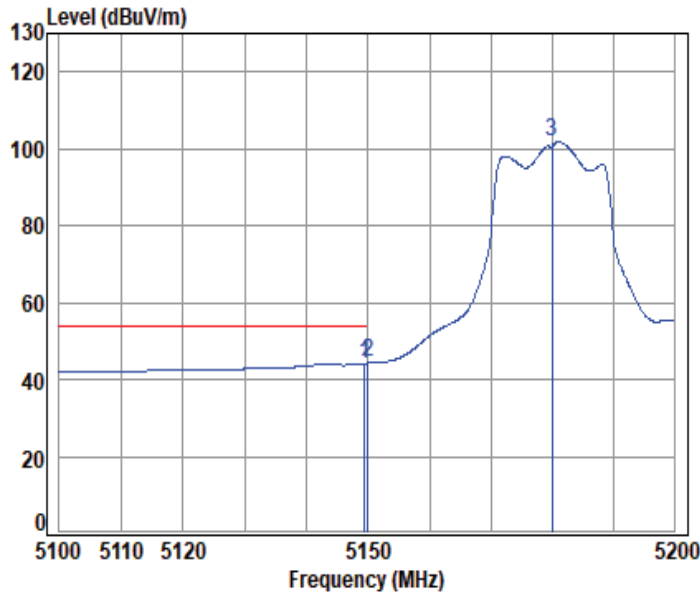

Condition: 3m HORIZONTAL

Job No : 01607WM

Mode : 5180 Band edge

: 5G Wi-Fi 11ac20

	Cable	Ant	Preamp	Read	Limit	Over			
Freq	Loss	Factor	Factor	Level	Level	Line	Limit	Remark	
MHz	dB	dB/m	dB	dBuV	dBuV/m	dBuV/m	dB		
1	5149.458	10.14	32.40	30.55	32.18	44.17	54.00	-9.83	Average
2	pp 5149.980	10.14	32.40	30.55	32.34	44.33	54.00	-9.67	Average
3	5180.000	10.25	32.46	30.56	89.66	101.81	-----	-----	Average



Unless otherwise agreed in writing, this document is issued by the Company subject to its General Conditions of Service printed overleaf, available on request or accessible at <https://www.sgs.com/en/Terms-and-Conditions>. Attention is drawn to the limitation of liability, indemnification and jurisdiction issues defined therein. Any holder of this document is advised that information contained hereon reflects the Company's findings at the time of its intervention only and within the limits of Client's instructions, if any. The Company's sole responsibility is to its Client and this document does not exonerate parties to a transaction from exercising all their rights and obligations under the transaction documents. This document cannot be reproduced except in full, without prior written approval of the Company. Any unauthorized alteration, forgery or falsification of the content or appearance of this document is unlawful and offenders may be prosecuted to the fullest extent of the law. Unless otherwise stated the results shown in this test report refer only to the sample(s) tested and such sample(s) are retained for 30 days only.

Attention: To check the authenticity of testing /inspection report & certificate, please contact us at telephone: (86-755) 8307 1443, or email: CN.Doccheck@sgs.com
 No.1 Workshop, M-10, Middle Section, Science & Technology Park, Nanshan District, Shenzhen, Guangdong, China 518057 t (86-755) 26012053 f (86-755) 26710594 www.sgs.com.cn
 中国·广东·深圳市南山区科技园中区M-10栋1号厂房 邮编: 518057 t (86-755) 26012053 f (86-755) 26710594 sgs.china@sgs.com

11ac_VHT(20M)_TX_CH_36_Vertical-Peak

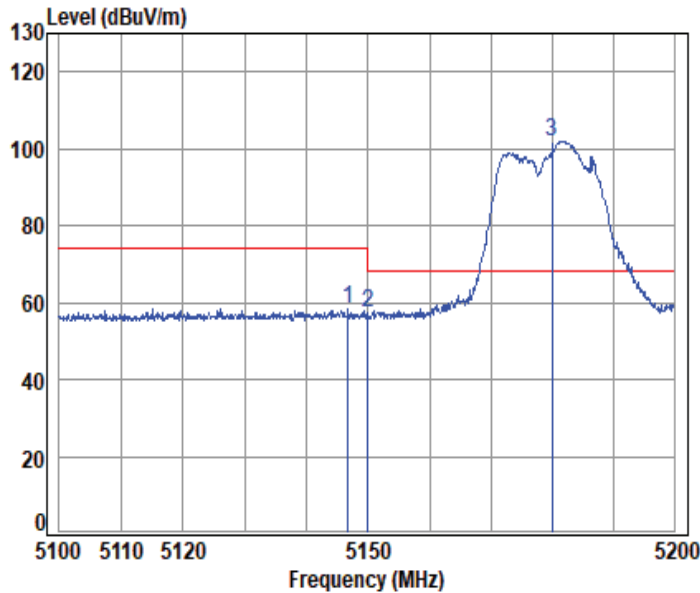

Condition: 3m VERTICAL

Job No : 01607WM

Mode : 5180 Band edge

: 5G Wi-Fi 11ac20

	Cable	Ant	Preamp	Read	Limit	Over			
Freq	Loss	Factor	Factor	Level	Level	Line	Limit	Remark	
MHz	dB	dB/m	dB	dBuV	dBuV/m	dBuV/m	dB		
1	5146.758	10.13	32.39	30.55	46.60	58.57	74.00	-15.43 peak	
2	5149.980	10.14	32.40	30.55	45.15	57.14	74.00	-16.86 peak	
3	pp 5180.000	10.25	32.46	30.56	89.91	102.06	68.20	33.86 peak	



Unless otherwise agreed in writing, this document is issued by the Company subject to its General Conditions of Service printed overleaf, available on request or accessible at <https://www.sgs.com/en/Terms-and-Conditions>. Attention is drawn to the limitation of liability, indemnification and jurisdiction issues defined therein. Any holder of this document is advised that information contained hereon reflects the Company's findings at the time of its intervention only and within the limits of Client's instructions, if any. The Company's sole responsibility is to its Client and this document does not exonerate parties to a transaction from exercising all their rights and obligations under the transaction documents. This document cannot be reproduced except in full, without prior written approval of the Company. Any unauthorized alteration, forgery or falsification of the content or appearance of this document is unlawful and offenders may be prosecuted to the fullest extent of the law. Unless otherwise stated the results shown in this test report refer only to the sample(s) tested and such sample(s) are retained for 30 days only.

Attention: To check the authenticity of testing /inspection report & certificate, please contact us at telephone: (86-755) 8307 1443, or email: CN.Doccheck@sgs.com
 No.1 Workshop, M-10, Middle Section, Science & Technology Park, Nanshan District, Shenzhen, Guangdong, China 518057 t (86-755) 26012053 f (86-755) 26710594 www.sgs.com.cn
 中国·广东·深圳市南山区科技园中区M-10栋1号厂房 邮编: 518057 t (86-755) 26012053 f (86-755) 26710594 sgs.china@sgs.com

11ac_VHT(20M)_TX_CH_36_Vertical-Avg

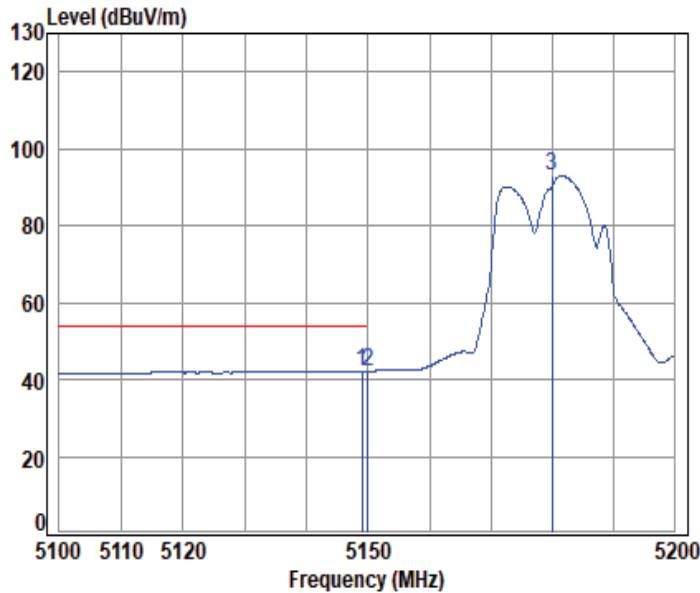

Condition: 3m VERTICAL

Job No : 01607WM

Mode : 5180 Band edge

: 5G Wi-Fi 11ac20

	Cable	Ant	Preamp	Read	Limit	Over			
	Freq	Loss	Factor	Factor	Level	Level	Line	Limit	Remark
	MHz	dB	dB/m	dB	dBuV	dBuV/m	dBuV/m	dB	
1	5148.958	10.14	32.40	30.55	30.20	42.19	54.00	-11.81	Average
2	pp 5149.980	10.14	32.40	30.55	30.21	42.20	54.00	-11.80	Average
3	5180.000	10.25	32.46	30.56	80.73	92.88	-----	-----	Average



Unless otherwise agreed in writing, this document is issued by the Company subject to its General Conditions of Service printed overleaf, available on request or accessible at <https://www.sgs.com/en/Terms-and-Conditions>. Attention is drawn to the limitation of liability, indemnification and jurisdiction issues defined therein. Any holder of this document is advised that information contained hereon reflects the Company's findings at the time of its intervention only and within the limits of Client's instructions, if any. The Company's sole responsibility is to its Client and this document does not exonerate parties to a transaction from exercising all their rights and obligations under the transaction documents. This document cannot be reproduced except in full, without prior written approval of the Company. Any unauthorized alteration, forgery or falsification of the content or appearance of this document is unlawful and offenders may be prosecuted to the fullest extent of the law. Unless otherwise stated the results shown in this test report refer only to the sample(s) tested and such sample(s) are retained for 30 days only.

Attention: To check the authenticity of testing /inspection report & certificate, please contact us at telephone: (86-755) 8307 1443, or email: CN.Doccheck@sgs.com
 No.1 Workshop, M-10, Middle Section, Science & Technology Park, Nanshan District, Shenzhen, Guangdong, China 518057 t (86-755) 26012053 f (86-755) 26710594 www.sgsgroup.com.cn
 中国·广东·深圳市南山区科技园中区M-10栋1号厂房 邮编: 518057 t (86-755) 26012053 f (86-755) 26710594 sgs.china@sgs.com

11ac_VHT(40M)_TX_CH_38_Horizontal-Peak

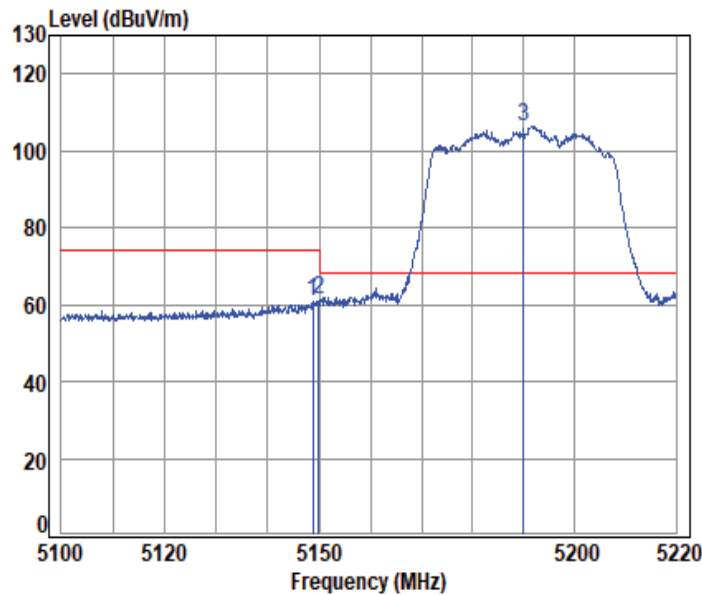

Condition: 3m HORIZONTAL

Job No : 01607WM

Mode : 5190 Band edge

: 5G Wi-Fi 11ac40

	Cable	Ant	Preamp	Read	Limit	Over			
Freq	Loss	Factor	Factor	Level	Level	Line	Limit	Remark	
MHz	dB	dB/m	dB	dBuV	dBuV/m	dBuV/m	dB		
1	5148.743	10.14	32.40	30.55	48.71	60.70	74.00	-13.30	peak
2	5149.980	10.14	32.40	30.55	49.22	61.21	74.00	-12.79	peak
3	pp 5190.000	10.29	32.48	30.56	94.11	106.32	68.20	38.12	peak



Unless otherwise agreed in writing, this document is issued by the Company subject to its General Conditions of Service printed overleaf, available on request or accessible at <https://www.sgs.com/en/Terms-and-Conditions>. Attention is drawn to the limitation of liability, indemnification and jurisdiction issues defined therein. Any holder of this document is advised that information contained hereon reflects the Company's findings at the time of its intervention only and within the limits of Client's instructions, if any. The Company's sole responsibility is to its Client and this document does not exonerate parties to a transaction from exercising all their rights and obligations under the transaction documents. This document cannot be reproduced except in full, without prior written approval of the Company. Any unauthorized alteration, forgery or falsification of the content or appearance of this document is unlawful and offenders may be prosecuted to the fullest extent of the law. Unless otherwise stated the results shown in this test report refer only to the sample(s) tested and such sample(s) are retained for 30 days only.

Attention: To check the authenticity of testing /inspection report & certificate, please contact us at telephone: (86-755) 8307 1443, or email: CN.Doccheck@sgs.com
 No.1 Workshop, M-10, Middle Section, Science & Technology Park, Nanshan District, Shenzhen, Guangdong, China 518057 t (86-755) 26012053 f (86-755) 26710594 www.sgsgroup.com.cn
 中国·广东·深圳市南山区科技园中区M-10栋1号厂房 邮编: 518057 t (86-755) 26012053 f (86-755) 26710594 sgs.china@sgs.com

11ac_VHT(40M)_TX_CH_38_Horizontal-Avg

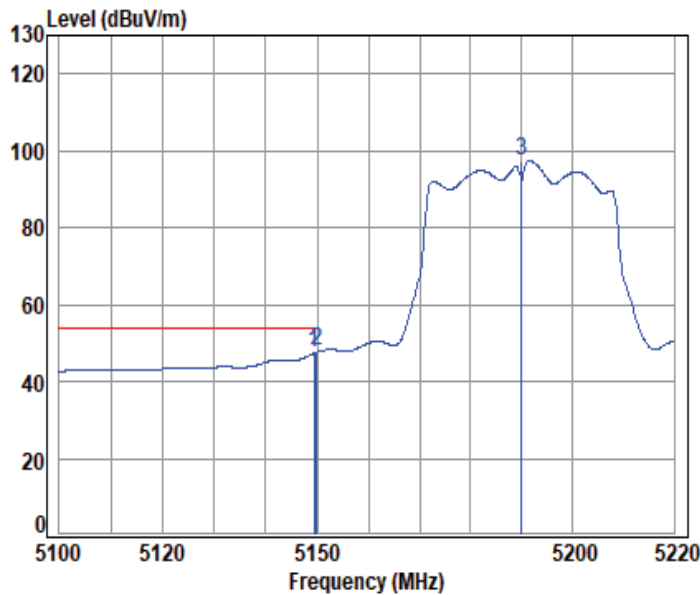

Condition: 3m HORIZONTAL

Job No : 01607WM

Mode : 5190 Band edge

: 5G Wi-Fi 11ac40

	Cable	Ant	Preamp	Read	Limit	Over			
Freq	Loss	Factor	Factor	Level	Level	Line	Limit	Remark	
MHz	dB	dB/m	dB	dBuV	dBuV/m	dBuV/m	dB		
1	5149.461	10.14	32.40	30.55	35.39	47.38	54.00	-6.62	Average
2	pp 5149.980	10.14	32.40	30.55	35.79	47.78	54.00	-6.22	Average
3	5190.000	10.29	32.48	30.56	85.22	97.43	-----	-----	Average



Unless otherwise agreed in writing, this document is issued by the Company subject to its General Conditions of Service printed overleaf, available on request or accessible at <https://www.sgs.com/en/Terms-and-Conditions>. Attention is drawn to the limitation of liability, indemnification and jurisdiction issues defined therein. Any holder of this document is advised that information contained hereon reflects the Company's findings at the time of its intervention only and within the limits of Client's instructions, if any. The Company's sole responsibility is to its Client and this document does not exonerate parties to a transaction from exercising all their rights and obligations under the transaction documents. This document cannot be reproduced except in full, without prior written approval of the Company. Any unauthorized alteration, forgery or falsification of the content or appearance of this document is unlawful and offenders may be prosecuted to the fullest extent of the law. Unless otherwise stated the results shown in this test report refer only to the sample(s) tested and such sample(s) are retained for 30 days only.

11ac_VHT(40M)_TX_CH_38_Vertical-Peak

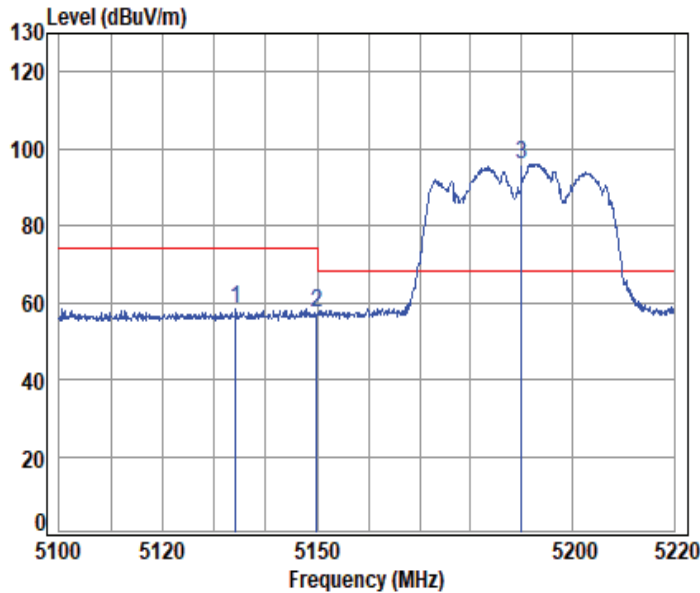

Condition: 3m VERTICAL

Job No : 01607WM

Mode : 5190 Band edge

: 5G Wi-Fi 11ac40

	Cable	Ant	Preamp	Read	Limit	Over		
Freq	Loss	Factor	Factor	Level	Level	Line	Limit	Remark
MHz	dB	dB/m	dB	dBuV	dBuV/m	dBuV/m	dB	
1	5134.155	10.08	32.37	30.54	46.39	58.30	74.00	-15.70 peak
2	5149.980	10.14	32.40	30.55	45.19	57.18	74.00	-16.82 peak
3	pp 5190.000	10.29	32.48	30.56	83.81	96.02	68.20	27.82 peak



Unless otherwise agreed in writing, this document is issued by the Company subject to its General Conditions of Service printed overleaf, available on request or accessible at <https://www.sgs.com/en/Terms-and-Conditions>. Attention is drawn to the limitation of liability, indemnification and jurisdiction issues defined therein. Any holder of this document is advised that information contained hereon reflects the Company's findings at the time of its intervention only and within the limits of Client's instructions, if any. The Company's sole responsibility is to its Client and this document does not exonerate parties to a transaction from exercising all their rights and obligations under the transaction documents. This document cannot be reproduced except in full, without prior written approval of the Company. Any unauthorized alteration, forgery or falsification of the content or appearance of this document is unlawful and offenders may be prosecuted to the fullest extent of the law. Unless otherwise stated the results shown in this test report refer only to the sample(s) tested and such sample(s) are retained for 30 days only.

Attention: To check the authenticity of testing /inspection report & certificate, please contact us at telephone: (86-755) 8307 1443, or email: CN.Doccheck@sgs.com
 No.1 Workshop, M-10, Middle Section, Science & Technology Park, Nanshan District, Shenzhen, Guangdong, China 518057 t (86-755) 26012053 f (86-755) 26710594 www.sgsgroup.com.cn
 中国·广东·深圳市南山区科技园中区M-10栋1号厂房 邮编: 518057 t (86-755) 26012053 f (86-755) 26710594 sgs.china@sgs.com

11ac_VHT(40M)_TX_CH_38_Vertical-Avg

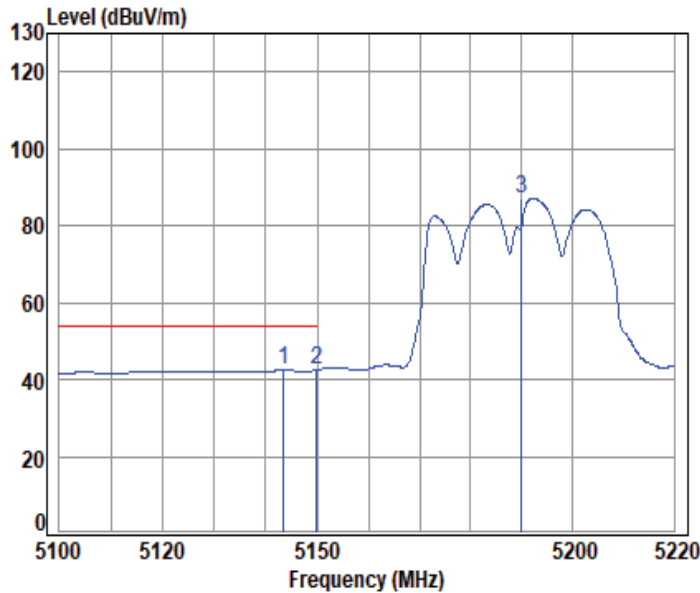

Condition: 3m VERTICAL

Job No : 01607WM

Mode : 5190 Band edge

: 5G Wi-Fi 11ac40

	Cable	Ant	Preamp	Read	Limit	Over			
Freq	Loss	Factor	Factor	Level	Level	Line	Limit	Remark	
MHz	dB	dB/m	dB	dBuV	dBuV/m	dBuV/m	dB		
1	5143.477	10.12	32.39	30.55	30.41	42.37	54.00	-11.63	Average
2	pp 5149.980	10.14	32.40	30.55	30.55	42.54	54.00	-11.46	Average
3	5190.000	10.29	32.48	30.56	74.75	86.96	-----	-----	Average



Unless otherwise agreed in writing, this document is issued by the Company subject to its General Conditions of Service printed overleaf, available on request or accessible at <https://www.sgs.com/en/Terms-and-Conditions>. Attention is drawn to the limitation of liability, indemnification and jurisdiction issues defined therein. Any holder of this document is advised that information contained hereon reflects the Company's findings at the time of its intervention only and within the limits of Client's instructions, if any. The Company's sole responsibility is to its Client and this document does not exonerate parties to a transaction from exercising all their rights and obligations under the transaction documents. This document cannot be reproduced except in full, without prior written approval of the Company. Any unauthorized alteration, forgery or falsification of the content or appearance of this document is unlawful and offenders may be prosecuted to the fullest extent of the law. Unless otherwise stated the results shown in this test report refer only to the sample(s) tested and such sample(s) are retained for 30 days only.

Attention: To check the authenticity of testing /inspection report & certificate, please contact us at telephone: (86-755) 8307 1443, or email: CN.Doccheck@sgs.com
 No.1 Workshop, M-10, Middle Section, Science & Technology Park, Nanshan District, Shenzhen, Guangdong, China 518057 t (86-755) 26012053 f (86-755) 26710594 www.sgs.com.cn
 中国·广东·深圳市南山区科技园中区M-10栋1号厂房 邮编: 518057 t (86-755) 26012053 f (86-755) 26710594 sgs.china@sgs.com

11ac_VHT(80M)_TX_CH_42_Horizontal-Peak

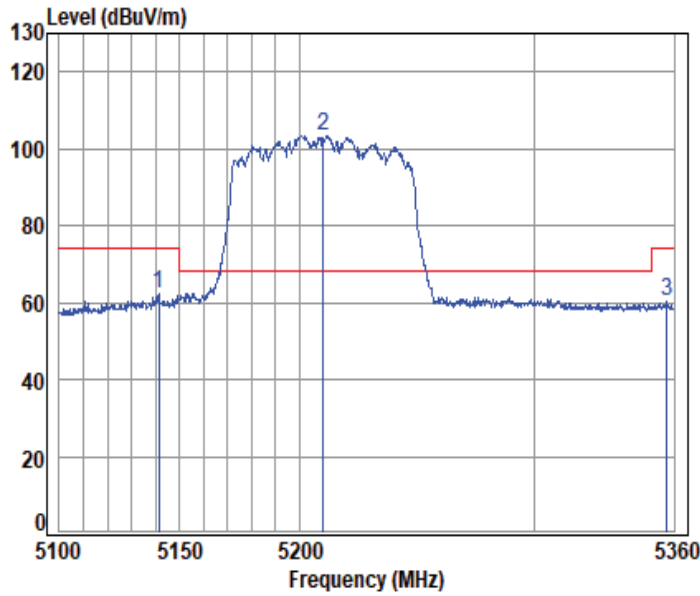

Condition: 3m HORIZONTAL

Job No : 01607WM

Mode : 5210 Band edge

: 5G Wi-Fi 11ac80

	Cable	Ant	Preamp	Read	Limit	Over			
Freq	Loss	Factor	Factor	Level	Level	Line	Limit	Remark	
MHz	dB	dB/m	dB	dBuV	dBuV/m	dBuV/m	dB		
1	5141.248	10.11	32.38	30.55	50.53	62.47	74.00	-11.53 peak	
2	pp 5210.000	10.32	32.52	30.57	91.22	103.49	68.20	35.29 peak	
3	5357.069	10.47	32.80	30.61	47.52	60.18	74.00	-13.82 peak	



Unless otherwise agreed in writing, this document is issued by the Company subject to its General Conditions of Service printed overleaf, available on request or accessible at <https://www.sgs.com/en/Terms-and-Conditions>. Attention is drawn to the limitation of liability, indemnification and jurisdiction issues defined therein. Any holder of this document is advised that information contained hereon reflects the Company's findings at the time of its intervention only and within the limits of Client's instructions, if any. The Company's sole responsibility is to its Client and this document does not exonerate parties to a transaction from exercising all their rights and obligations under the transaction documents. This document cannot be reproduced except in full, without prior written approval of the Company. Any unauthorized alteration, forgery or falsification of the content or appearance of this document is unlawful and offenders may be prosecuted to the fullest extent of the law. Unless otherwise stated the results shown in this test report refer only to the sample(s) tested and such sample(s) are retained for 30 days only.

Attention: To check the authenticity of testing /inspection report & certificate, please contact us at telephone: (86-755) 8307 1443, or email: CN.Doccheck@sgs.com
 No.1 Workshop, M-10, Middle Section, Science & Technology Park, Nanshan District, Shenzhen, Guangdong, China 518057 t (86-755) 26012053 f (86-755) 26710594 www.sgs.com.cn
 中国·广东·深圳市南山区科技园中区M-10栋1号厂房 邮编: 518057 t (86-755) 26012053 f (86-755) 26710594 sgs.china@sgs.com

11ac_VHT(80M)_TX_CH_42_Horizontal-Avg

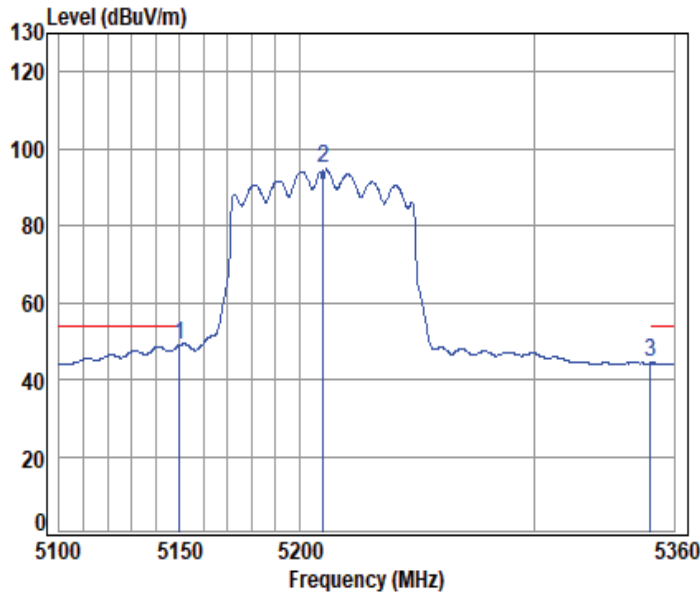

Condition: 3m HORIZONTAL

Job No : 01607WM

Mode : 5210 Band edge

: 5G Wi-Fi 11ac80

	Cable	Ant	Preamp	Read	Limit	Over			
Freq	Loss	Factor	Factor	Level	Level	Line	Limit	Remark	
MHz	dB	dB/m	dB	dBuV	dBuV/m	dBuV/m	dB		
1 pp 5149.947	10.14	32.40	30.55	37.00	48.99	54.00	-5.01	Average	
2 5210.000	10.32	32.52	30.57	82.45	94.72	-----	-----	Average	
3 5349.882	10.45	32.80	30.61	31.61	44.25	-----	-----	Average	



Unless otherwise agreed in writing, this document is issued by the Company subject to its General Conditions of Service printed overleaf, available on request or accessible at <https://www.sgs.com/en/Terms-and-Conditions>. Attention is drawn to the limitation of liability, indemnification and jurisdiction issues defined therein. Any holder of this document is advised that information contained hereon reflects the Company's findings at the time of its intervention only and within the limits of Client's instructions, if any. The Company's sole responsibility is to its Client and this document does not exonerate parties to a transaction from exercising all their rights and obligations under the transaction documents. This document cannot be reproduced except in full, without prior written approval of the Company. Any unauthorized alteration, forgery or falsification of the content or appearance of this document is unlawful and offenders may be prosecuted to the fullest extent of the law. Unless otherwise stated the results shown in this test report refer only to the sample(s) tested and such sample(s) are retained for 30 days only.

Attention: To check the authenticity of testing /inspection report & certificate, please contact us at telephone: (86-755) 8307 1443, or email: CN.Doccheck@sgs.com
 No.1 Workshop, M-10, Middle Section, Science & Technology Park, Nanshan District, Shenzhen, Guangdong, China 518057 t (86-755) 26012053 f (86-755) 26710594 www.sgs.com.cn
 中国·广东·深圳市南山区科技园中区M-10栋1号厂房 邮编: 518057 t (86-755) 26012053 f (86-755) 26710594 sgs.china@sgs.com

11ac_VHT(80M)_TX_CH_42_Vertical-Peak

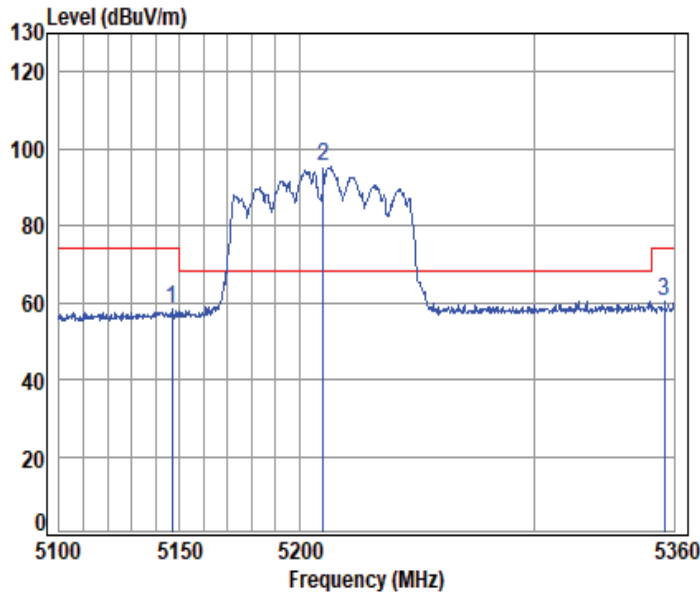

Condition: 3m VERTICAL

Job No : 01607WM

Mode : 5210 Band edge

: 5G Wi-Fi 11ac80

	Cable	Ant	Preamp	Read	Limit	Over		
Freq	Loss	Factor	Factor	Level	Level	Line	Limit	Remark
MHz	dB	dB/m	dB	dBuV	dBuV/m	dBuV/m	dB	
1	5146.619	10.13	32.39	30.55	46.54	58.51	74.00	-15.49 peak
2	pp 5210.000	10.32	32.52	30.57	83.03	95.30	68.20	27.10 peak
3	5356.004	10.47	32.80	30.61	47.61	60.27	74.00	-13.73 peak



11ac_VHT(80M)_TX_CH_42_Vertical-Avg

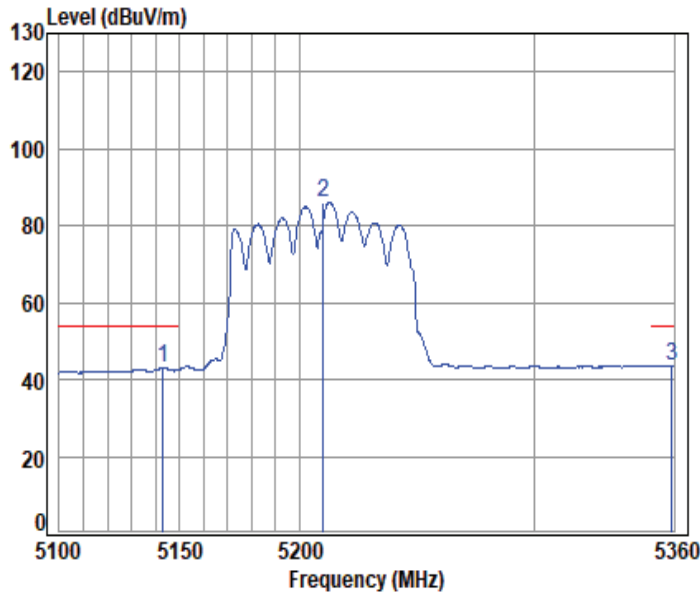

Condition: 3m VERTICAL

Job No : 01607WM

Mode : 5210 Band edge

: 5G Wi-Fi 11ac80

	Cable	Ant	Preamp	Read	Limit	Over			
Freq	Loss	Factor	Factor	Level	Level	Line	Limit	Remark	
MHz	dB	dB/m	dB	dBuV	dBuV/m	dBuV/m	dB		
1	5143.037	10.11	32.39	30.55	31.01	42.96	54.00	-11.04	Average
2	5210.000	10.32	32.52	30.57	73.68	85.95	-----	-----	Average
3	pp 5359.201	10.48	32.80	30.61	30.88	43.55	54.00	-10.45	Average



11ax_20M_TX_CH_36_Horizontal-Peak

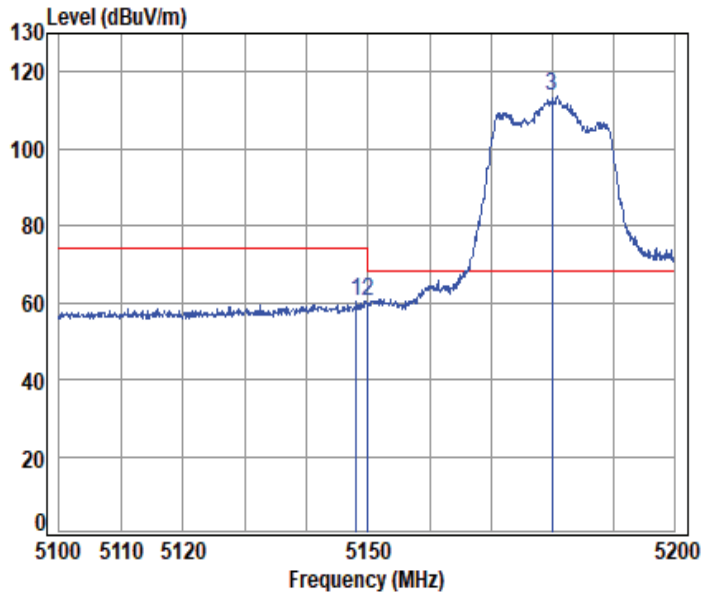

Condition: 3m HORIZONTAL

Job No : 01607WM

Mode : 5180 Band edge

: 5G Wi-Fi 11ax20

	Cable	Ant	Preamp	Read	Limit	Over			
	Freq	Loss	Factor	Factor	Level	Level	Line	Limit	Remark
	MHz	dB	dB/m	dB	dBuV	dBuV/m	dBuV/m	dB	
1	5148.058	10.13	32.40	30.55	48.54	60.52	74.00	-13.48	peak
2	5149.980	10.14	32.40	30.55	48.33	60.32	74.00	-13.68	peak
3	pp 5180.000	10.25	32.46	30.56	101.39	113.54	68.20	45.34	peak



Unless otherwise agreed in writing, this document is issued by the Company subject to its General Conditions of Service printed overleaf, available on request or accessible at <https://www.sgs.com/en/Terms-and-Conditions>. Attention is drawn to the limitation of liability, indemnification and jurisdiction issues defined therein. Any holder of this document is advised that information contained hereon reflects the Company's findings at the time of its intervention only and within the limits of Client's instructions, if any. The Company's sole responsibility is to its Client and this document does not exonerate parties to a transaction from exercising all their rights and obligations under the transaction documents. This document cannot be reproduced except in full, without prior written approval of the Company. Any unauthorized alteration, forgery or falsification of the content or appearance of this document is unlawful and offenders may be prosecuted to the fullest extent of the law. Unless otherwise stated the results shown in this test report refer only to the sample(s) tested and such sample(s) are retained for 30 days only.

Attention: To check the authenticity of testing /inspection report & certificate, please contact us at telephone: (86-755) 8307 1443, or email: CN.Doccheck@sgs.com
 No.1 Workshop, M-10, Middle Section, Science & Technology Park, Nanshan District, Shenzhen, Guangdong, China 518057 t (86-755) 26012053 f (86-755) 26710594 www.sgs.com.cn
 中国·广东·深圳市南山区科技园中区M-10栋1号厂房 邮编: 518057 t (86-755) 26012053 f (86-755) 26710594 sgs.china@sgs.com

11ax_20M_TX_CH_36_Horizontal-Avg

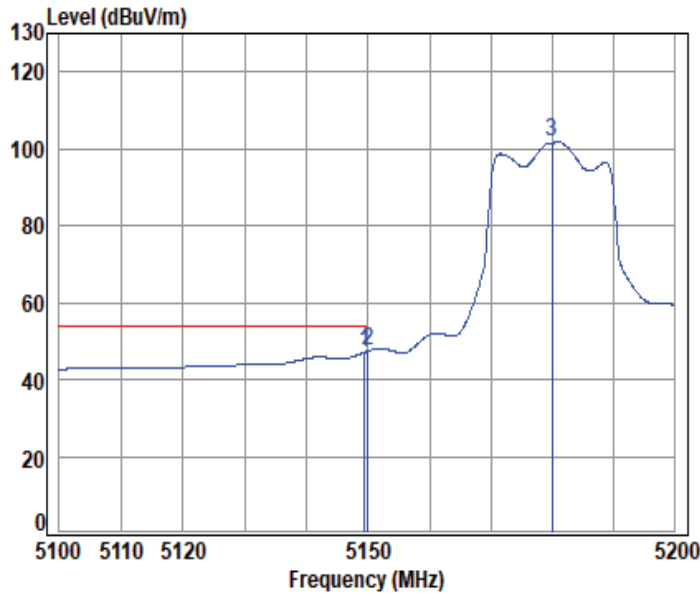

Condition: 3m HORIZONTAL

Job No : 01607WM

Mode : 5180 Band edge

: 5G Wi-Fi 11ax20

	Cable	Ant	Preamp	Read	Limit	Over			
Freq	Loss	Factor	Factor	Level	Level	Line	Limit	Remark	
MHz	dB	dB/m	dB	dBuV	dBuV/m	dBuV/m	dB		
1	5149.458	10.14	32.40	30.55	35.14	47.13	54.00	-6.87	Average
2	pp 5149.980	10.14	32.40	30.55	35.59	47.58	54.00	-6.42	Average
3	5180.000	10.25	32.46	30.56	89.79	101.94	-----	-----	Average



Unless otherwise agreed in writing, this document is issued by the Company subject to its General Conditions of Service printed overleaf, available on request or accessible at <https://www.sgs.com/en/Terms-and-Conditions>. Attention is drawn to the limitation of liability, indemnification and jurisdiction issues defined therein. Any holder of this document is advised that information contained hereon reflects the Company's findings at the time of its intervention only and within the limits of Client's instructions, if any. The Company's sole responsibility is to its Client and this document does not exonerate parties to a transaction from exercising all their rights and obligations under the transaction documents. This document cannot be reproduced except in full, without prior written approval of the Company. Any unauthorized alteration, forgery or falsification of the content or appearance of this document is unlawful and offenders may be prosecuted to the fullest extent of the law. Unless otherwise stated the results shown in this test report refer only to the sample(s) tested and such sample(s) are retained for 30 days only.

Attention: To check the authenticity of testing /inspection report & certificate, please contact us at telephone: (86-755) 8307 1443, or email: CN.Doccheck@sgs.com
 No.1 Workshop, M-10, Middle Section, Science & Technology Park, Nanshan District, Shenzhen, Guangdong, China 518057 t (86-755) 26012053 f (86-755) 26710594 www.sgs.com.cn
 中国·广东·深圳市南山区科技园中区M-10栋1号厂房 邮编: 518057 t (86-755) 26012053 f (86-755) 26710594 sgs.china@sgs.com

11ax_20M_TX_CH_36_Vertical-Peak

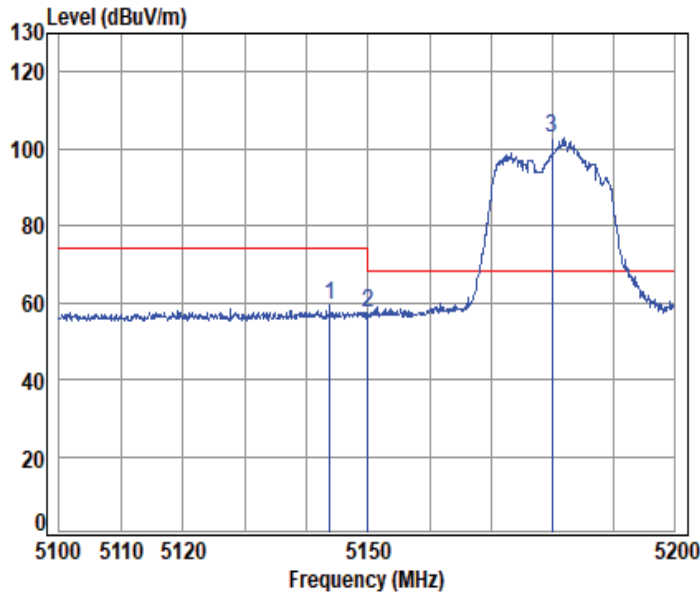

Condition: 3m VERTICAL

Job No : 01607WM

Mode : 5180 Band edge

: 5G Wi-Fi 11ax20

	Cable	Ant	Preamp	Read	Limit	Over			
Freq	Loss	Factor	Factor	Level	Level	Line	Limit	Remark	
MHz	dB	dB/m	dB	dBuV	dBuV/m	dBuV/m	dB		
1	5143.761	10.12	32.39	30.55	47.42	59.38	74.00	-14.62	peak
2	5149.980	10.14	32.40	30.55	45.45	57.44	74.00	-16.56	peak
3	pp 5180.000	10.25	32.46	30.56	90.61	102.76	68.20	34.56	peak



Unless otherwise agreed in writing, this document is issued by the Company subject to its General Conditions of Service printed overleaf, available on request or accessible at <https://www.sgs.com/en/Terms-and-Conditions>. Attention is drawn to the limitation of liability, indemnification and jurisdiction issues defined therein. Any holder of this document is advised that information contained hereon reflects the Company's findings at the time of its intervention only and within the limits of Client's instructions, if any. The Company's sole responsibility is to its Client and this document does not exonerate parties to a transaction from exercising all their rights and obligations under the transaction documents. This document cannot be reproduced except in full, without prior written approval of the Company. Any unauthorized alteration, forgery or falsification of the content or appearance of this document is unlawful and offenders may be prosecuted to the fullest extent of the law. Unless otherwise stated the results shown in this test report refer only to the sample(s) tested and such sample(s) are retained for 30 days only.

Attention: To check the authenticity of testing /inspection report & certificate, please contact us at telephone: (86-755) 8307 1443, or email: CN.Doccheck@sgs.com
 No.1 Workshop, M-10, Middle Section, Science & Technology Park, Nanshan District, Shenzhen, Guangdong, China 518057 t (86-755) 26012053 f (86-755) 26710594 www.sgs.com.cn
 中国·广东·深圳市南山区科技园中区M-10栋1号厂房 邮编: 518057 t (86-755) 26012053 f (86-755) 26710594 sgs.china@sgs.com

11ax_20M_TX_CH_36_Vertical-Avg

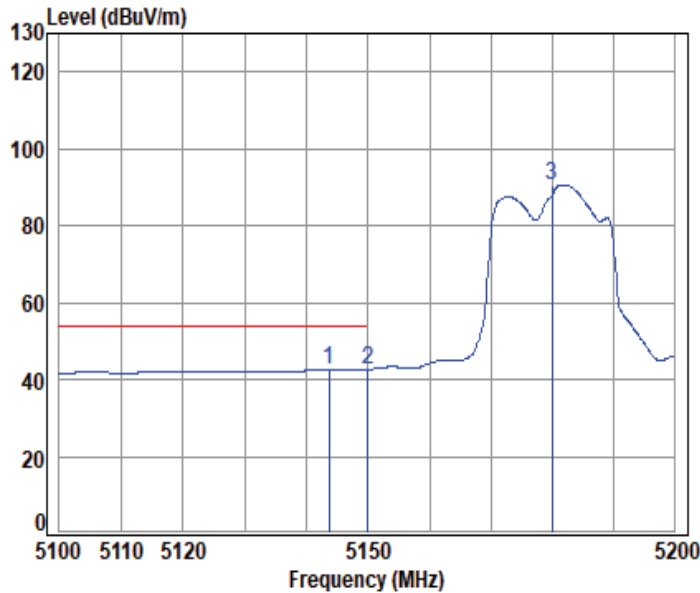

Condition: 3m VERTICAL

Job No : 01607WM

Mode : 5180 Band edge

: 5G Wi-Fi 11ax20

	Cable	Ant	Preamp	Read	Limit	Over			
Freq	Loss	Factor	Factor	Level	Level	Line	Limit	Remark	
MHz	dB	dB/m	dB	dBuV	dBuV/m	dBuV/m	dB		
1	5143.661	10.12	32.39	30.55	30.61	42.57	54.00	-11.43	Average
2	pp 5149.980	10.14	32.40	30.55	30.63	42.62	54.00	-11.38	Average
3	5180.000	10.25	32.46	30.56	78.48	90.63	-----	-----	Average



11ax_40M_TX_CH_38_Horizontal-Peak

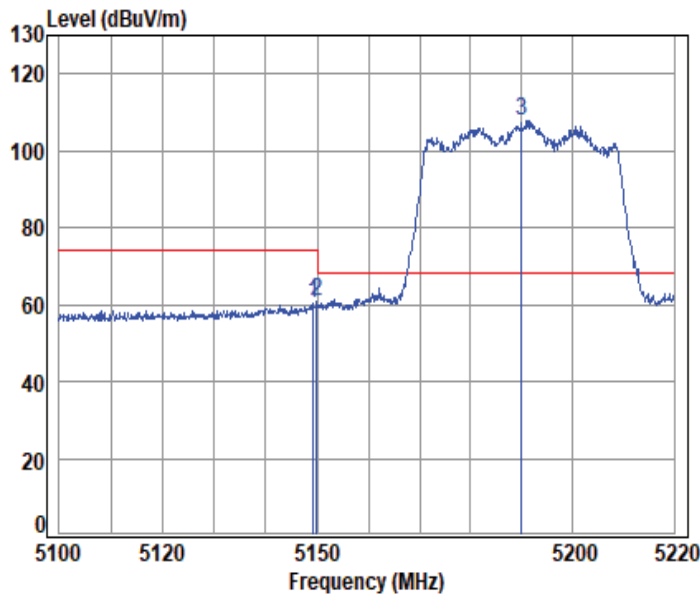

Condition: 3m HORIZONTAL

Job No : 01607WM

Mode : 5190 Band edge

: 5G Wi-Fi 11ax40

	Cable	Ant	Preamp	Read	Limit	Over			
Freq	Loss	Factor	Factor	Level	Level	Line	Limit	Remark	
MHz	dB	dB/m	dB	dBuV	dBuV/m	dBuV/m	dB		
1	5149.342	10.14	32.40	30.55	48.33	60.32	74.00	-13.68	peak
2	5149.980	10.14	32.40	30.55	48.79	60.78	74.00	-13.22	peak
3	pp 5190.000	10.29	32.48	30.56	95.65	107.86	68.20	39.66	peak



Unless otherwise agreed in writing, this document is issued by the Company subject to its General Conditions of Service printed overleaf, available on request or accessible at <https://www.sgs.com/en/Terms-and-Conditions>. Attention is drawn to the limitation of liability, indemnification and jurisdiction issues defined therein. Any holder of this document is advised that information contained hereon reflects the Company's findings at the time of its intervention only and within the limits of Client's instructions, if any. The Company's sole responsibility is to its Client and this document does not exonerate parties to a transaction from exercising all their rights and obligations under the transaction documents. This document cannot be reproduced except in full, without prior written approval of the Company. Any unauthorized alteration, forgery or falsification of the content or appearance of this document is unlawful and offenders may be prosecuted to the fullest extent of the law. Unless otherwise stated the results shown in this test report refer only to the sample(s) tested and such sample(s) are retained for 30 days only.

Attention: To check the authenticity of testing /inspection report & certificate, please contact us at telephone: (86-755) 8307 1443, or email: CN.Doccheck@sgs.com
 No.1 Workshop, M-10, Middle Section, Science & Technology Park, Nanshan District, Shenzhen, Guangdong, China 518057 t (86-755) 26012053 f (86-755) 26710594 www.sgs.com.cn
 中国·广东·深圳市南山区科技园中区M-10栋1号厂房 邮编: 518057 t (86-755) 26012053 f (86-755) 26710594 sgs.china@sgs.com

11ax_40M_TX_CH_38_Horizontal-Avg

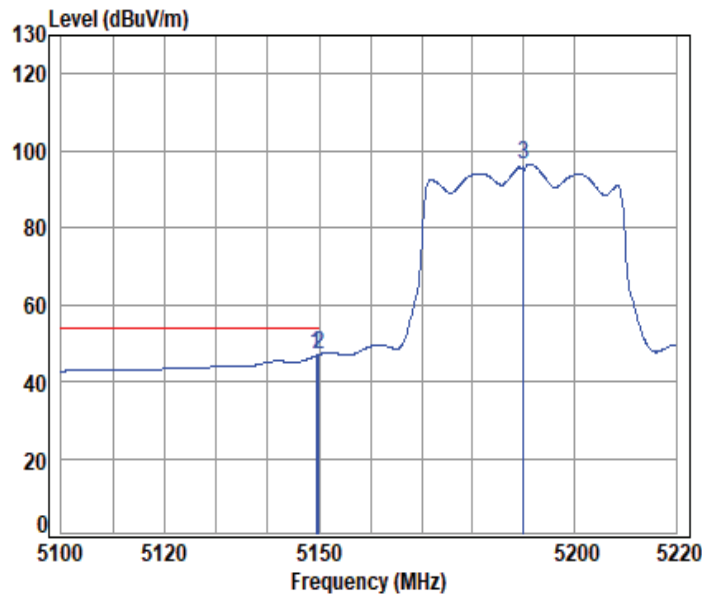

Condition: 3m HORIZONTAL

Job No : 01607WM

Mode : 5190 Band edge

: 5G Wi-Fi 11ax40

	Cable	Ant	Preamp	Read	Limit	Over			
Freq	Loss	Factor	Factor	Level	Level	Line	Limit	Remark	
MHz	dB	dB/m	dB	dBuV	dBuV/m	dBuV/m	dB		
1	5149.461	10.14	32.40	30.55	34.76	46.75	54.00	-7.25	Average
2	pp 5149.980	10.14	32.40	30.55	35.10	47.09	54.00	-6.91	Average
3	5190.000	10.29	32.48	30.56	84.41	96.62	-----	-----	Average



Unless otherwise agreed in writing, this document is issued by the Company subject to its General Conditions of Service printed overleaf, available on request or accessible at <https://www.sgs.com/en/Terms-and-Conditions>. Attention is drawn to the limitation of liability, indemnification and jurisdiction issues defined therein. Any holder of this document is advised that information contained hereon reflects the Company's findings at the time of its intervention only and within the limits of Client's instructions, if any. The Company's sole responsibility is to its Client and this document does not exonerate parties to a transaction from exercising all their rights and obligations under the transaction documents. This document cannot be reproduced except in full, without prior written approval of the Company. Any unauthorized alteration, forgery or falsification of the content or appearance of this document is unlawful and offenders may be prosecuted to the fullest extent of the law. Unless otherwise stated the results shown in this test report refer only to the sample(s) tested and such sample(s) are retained for 30 days only.

Attention: To check the authenticity of testing /inspection report & certificate, please contact us at telephone: (86-755) 8307 1443, or email: CN.Doccheck@sgs.com
 No.1 Workshop, M-10, Middle Section, Science & Technology Park, Nanshan District, Shenzhen, Guangdong, China 518057 t (86-755) 26012053 f (86-755) 26710594 www.sgs.com.cn
 中国·广东·深圳市南山区科技园中区M-10栋1号厂房 邮编: 518057 t (86-755) 26012053 f (86-755) 26710594 sgs.china@sgs.com

11ax_40M_TX_CH_38_Verical-Peak

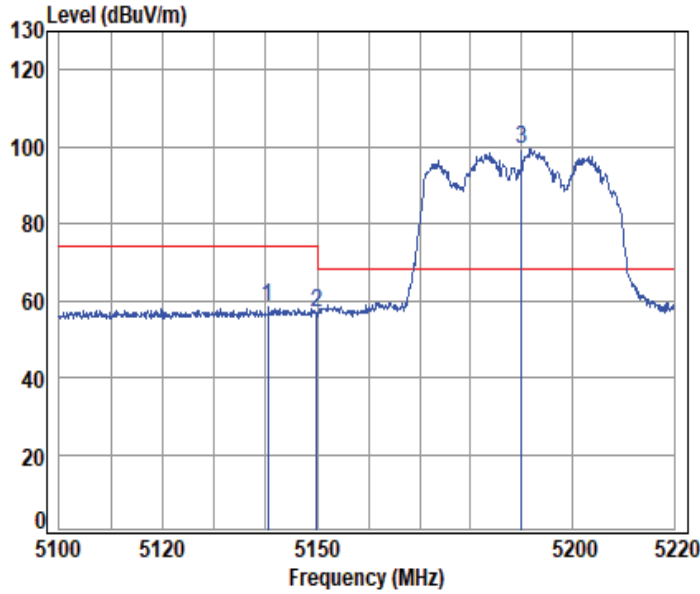

Condition: 3m VERTICAL

Job No : 01607WM

Mode : 5190 Band edge

: 5G Wi-Fi 11ax40

	Cable	Ant	Preamp	Read	Limit	Over		
Freq	Loss	Factor	Factor	Level	Level	Line	Limit	Remark
MHz	dB	dB/m	dB	dBuV	dBuV/m	dBuV/m	dB	
1	5140.487	10.10	32.38	30.55	46.37	58.30	74.00	-15.70 peak
2	5149.980	10.14	32.40	30.55	44.97	56.96	74.00	-17.04 peak
3	pp 5190.000	10.29	32.48	30.56	87.34	99.55	68.20	31.35 peak



Unless otherwise agreed in writing, this document is issued by the Company subject to its General Conditions of Service printed overleaf, available on request or accessible at <https://www.sgs.com/en/Terms-and-Conditions>. Attention is drawn to the limitation of liability, indemnification and jurisdiction issues defined therein. Any holder of this document is advised that information contained hereon reflects the Company's findings at the time of its intervention only and within the limits of Client's instructions, if any. The Company's sole responsibility is to its Client and this document does not exonerate parties to a transaction from exercising all their rights and obligations under the transaction documents. This document cannot be reproduced except in full, without prior written approval of the Company. Any unauthorized alteration, forgery or falsification of the content or appearance of this document is unlawful and offenders may be prosecuted to the fullest extent of the law. Unless otherwise stated the results shown in this test report refer only to the sample(s) tested and such sample(s) are retained for 30 days only.

11ax_40M_TX_CH_38_Verical-Avg

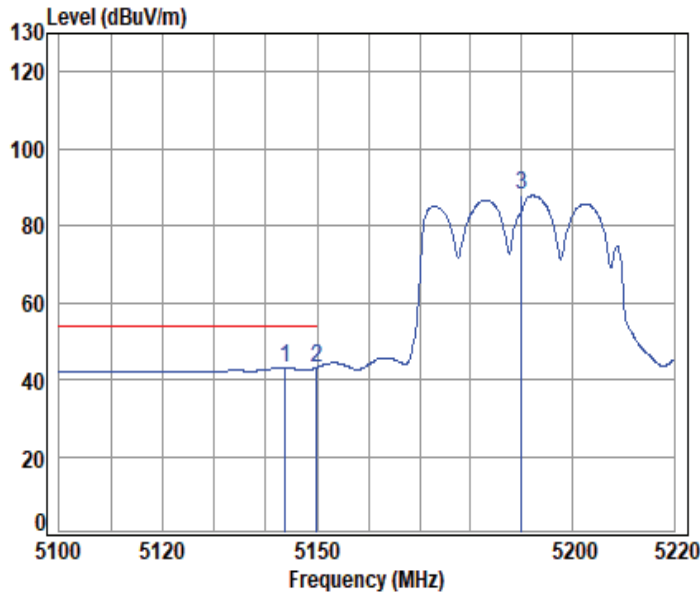

Condition: 3m VERTICAL

Job No : 01607WM

Mode : 5190 Band edge

: 5G Wi-Fi 11ax40

	Cable	Ant	Preamp	Read	Limit	Over			
Freq	Loss	Factor	Factor	Level	Level	Line	Limit	Remark	
MHz	dB	dB/m	dB	dBuV	dBuV/m	dBuV/m	dB		
1	5143.716	10.12	32.39	30.55	31.10	43.00	54.00	-10.94	Average
2	pp 5149.980	10.14	32.40	30.55	31.21	43.20	54.00	-10.80	Average
3	5190.000	10.29	32.48	30.56	75.58	87.79	-----	-----	Average



Unless otherwise agreed in writing, this document is issued by the Company subject to its General Conditions of Service printed overleaf, available on request or accessible at <https://www.sgs.com/en/Terms-and-Conditions>. Attention is drawn to the limitation of liability, indemnification and jurisdiction issues defined therein. Any holder of this document is advised that information contained hereon reflects the Company's findings at the time of its intervention only and within the limits of Client's instructions, if any. The Company's sole responsibility is to its Client and this document does not exonerate parties to a transaction from exercising all their rights and obligations under the transaction documents. This document cannot be reproduced except in full, without prior written approval of the Company. Any unauthorized alteration, forgery or falsification of the content or appearance of this document is unlawful and offenders may be prosecuted to the fullest extent of the law. Unless otherwise stated the results shown in this test report refer only to the sample(s) tested and such sample(s) are retained for 30 days only.

Attention: To check the authenticity of testing /inspection report & certificate, please contact us at telephone: (86-755) 8307 1443, or email: CN.Doccheck@sgs.com
 No.1 Workshop, M-10, Middle Section, Science & Technology Park, Nanshan District, Shenzhen, Guangdong, China 518057 t (86-755) 26012053 f (86-755) 26710594 www.sgs.com.cn
 中国·广东·深圳市南山区科技园中区M-10栋1号厂房 邮编: 518057 t (86-755) 26012053 f (86-755) 26710594 sgs.china@sgs.com

11ax_80M_TX_CH_42_Horizontal-Peak

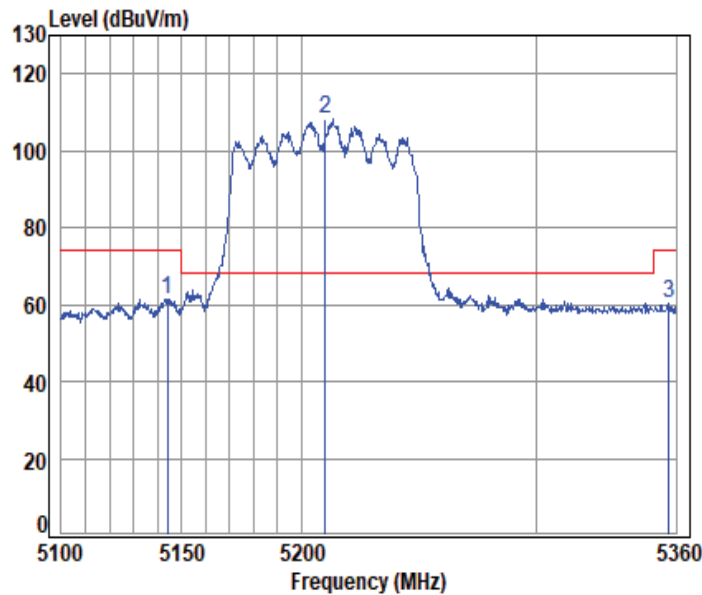

Condition: 3m HORIZONTAL

Job No : 01607WM

Mode : 5210 Band edge

: 5G Wi-Fi 11ax80

	Cable	Ant	Preamp	Read	Limit	Over		
Freq	Loss	Factor	Factor	Level	Level	Line	Limit	Remark
MHz	dB	dB/m	dB	dBuV	dBuV/m	dBuV/m	dB	
1	5144.060	10.12	32.39	30.55	49.50	61.46	74.00	-12.54 peak
2	pp 5210.000	10.32	32.52	30.57	95.90	108.17	68.20	39.97 peak
3	5357.069	10.47	32.80	30.61	47.73	60.39	74.00	-13.61 peak



Unless otherwise agreed in writing, this document is issued by the Company subject to its General Conditions of Service printed overleaf, available on request or accessible at <https://www.sgs.com/en/Terms-and-Conditions>. Attention is drawn to the limitation of liability, indemnification and jurisdiction issues defined therein. Any holder of this document is advised that information contained hereon reflects the Company's findings at the time of its intervention only and within the limits of Client's instructions, if any. The Company's sole responsibility is to its Client and this document does not exonerate parties to a transaction from exercising all their rights and obligations under the transaction documents. This document cannot be reproduced except in full, without prior written approval of the Company. Any unauthorized alteration, forgery or falsification of the content or appearance of this document is unlawful and offenders may be prosecuted to the fullest extent of the law. Unless otherwise stated the results shown in this test report refer only to the sample(s) tested and such sample(s) are retained for 30 days only.

Attention: To check the authenticity of testing /inspection report & certificate, please contact us at telephone: (86-755) 8307 1443, or email: CN.Doccheck@sgs.com
 No.1 Workshop, M-10, Middle Section, Science & Technology Park, Nanshan District, Shenzhen, Guangdong, China 518057 t (86-755) 26012053 f (86-755) 26710594 www.sgs.com.cn
 中国·广东·深圳市南山区科技园中区M-10栋1号厂房 邮编: 518057 t (86-755) 26012053 f (86-755) 26710594 sgs.china@sgs.com

11ax_80M_TX_CH_42_Horizontal-Avg

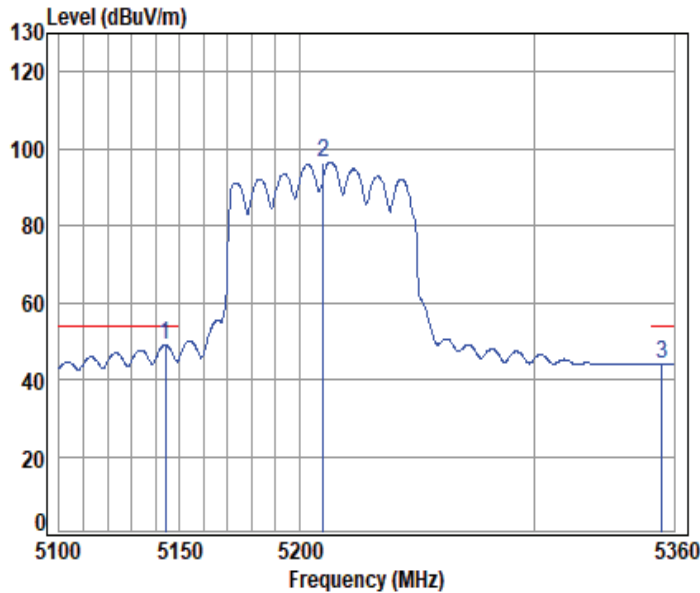

Condition: 3m HORIZONTAL

Job No : 01607WM

Mode : 5210 Band edge

: 5G Wi-Fi 11ax80

	Cable	Ant	Preamp	Read	Limit	Over			
Freq	Loss	Factor	Factor	Level	Level	Line	Limit	Remark	
MHz	dB	dB/m	dB	dBuV	dBuV/m	dBuV/m	dB		
1 pp 5144.060	10.12	32.39	30.55	36.98	48.94	54.00	-5.06	Average	
2 5210.000	10.32	32.52	30.57	84.32	96.59	-----	-----	Average	
3 5354.672	10.47	32.80	30.61	31.48	44.14	54.00	-9.86	Average	



Unless otherwise agreed in writing, this document is issued by the Company subject to its General Conditions of Service printed overleaf, available on request or accessible at <https://www.sgs.com/en/Terms-and-Conditions>. Attention is drawn to the limitation of liability, indemnification and jurisdiction issues defined therein. Any holder of this document is advised that information contained hereon reflects the Company's findings at the time of its intervention only and within the limits of Client's instructions, if any. The Company's sole responsibility is to its Client and this document does not exonerate parties to a transaction from exercising all their rights and obligations under the transaction documents. This document cannot be reproduced except in full, without prior written approval of the Company. Any unauthorized alteration, forgery or falsification of the content or appearance of this document is unlawful and offenders may be prosecuted to the fullest extent of the law. Unless otherwise stated the results shown in this test report refer only to the sample(s) tested and such sample(s) are retained for 30 days only.

Attention: To check the authenticity of testing /inspection report & certificate, please contact us at telephone: (86-755) 8307 1443, or email: CN.Doccheck@sgs.com

11ax_80M_TX_CH_42_Vertical-Peak

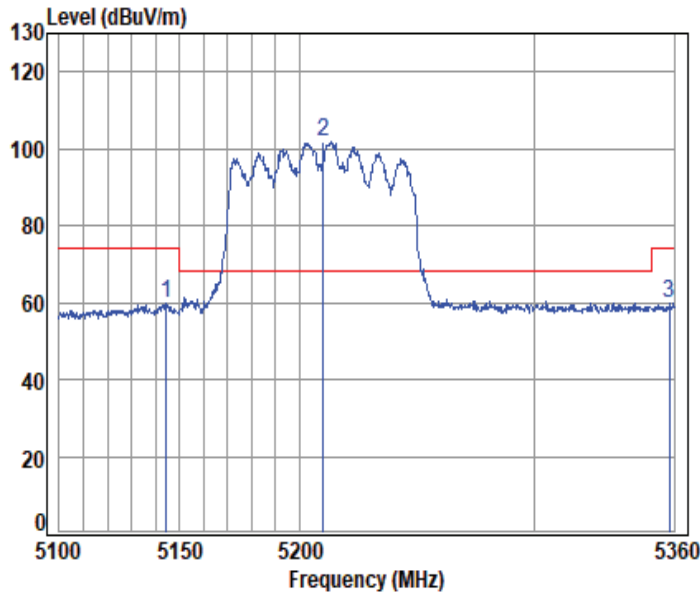

Condition: 3m VERTICAL

Job No : 01607WM

Mode : 5210 Band edge

: 5G Wi-Fi 11ax80

	Cable	Ant	Preamp	Read	Limit	Over		
Freq	Loss	Factor	Factor	Level	Level	Line	Limit	Remark
MHz	dB	dB/m	dB	dBuV	dBuV/m	dBuV/m	dB	
1	5144.316	10.12	32.39	30.55	47.65	59.61	74.00	-14.39 peak
2	pp 5210.000	10.32	32.52	30.57	89.47	101.74	68.20	33.54 peak
3	5357.868	10.48	32.80	30.61	47.32	59.99	74.00	-14.01 peak



Unless otherwise agreed in writing, this document is issued by the Company subject to its General Conditions of Service printed overleaf, available on request or accessible at <https://www.sgs.com/en/Terms-and-Conditions>. Attention is drawn to the limitation of liability, indemnification and jurisdiction issues defined therein. Any holder of this document is advised that information contained hereon reflects the Company's findings at the time of its intervention only and within the limits of Client's instructions, if any. The Company's sole responsibility is to its Client and this document does not exonerate parties to a transaction from exercising all their rights and obligations under the transaction documents. This document cannot be reproduced except in full, without prior written approval of the Company. Any unauthorized alteration, forgery or falsification of the content or appearance of this document is unlawful and offenders may be prosecuted to the fullest extent of the law. Unless otherwise stated the results shown in this test report refer only to the sample(s) tested and such sample(s) are retained for 30 days only.

Attention: To check the authenticity of testing /inspection report & certificate, please contact us at telephone: (86-755) 8307 1443, or email: CN.Doccheck@sgs.com
 No.1 Workshop, M-10, Middle Section, Science & Technology Park, Nanshan District, Shenzhen, Guangdong, China 518057 t (86-755) 26012053 f (86-755) 26710594 www.sgs.com.cn
 中国·广东·深圳市南山区科技园中区M-10栋1号厂房 邮编: 518057 t (86-755) 26012053 f (86-755) 26710594 sgs.china@sgs.com

11ax_80M_TX_CH_42_Vertical-Avg

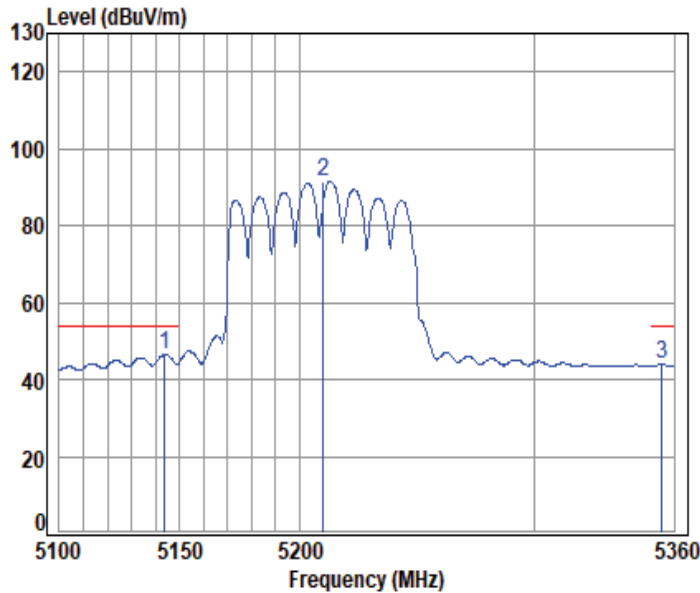

Condition: 3m VERTICAL

Job No : 01607WM

Mode : 5210 Band edge

: 5G Wi-Fi 11ax80

	Cable	Ant	Preamp	Read	Limit	Over			
Freq	Loss	Factor	Factor	Level	Level	Line	Limit	Remark	
MHz	dB	dB/m	dB	dBuV	dBuV/m	dBuV/m	dB		
1 pp 5143.805	10.12	32.39	30.55	34.53	46.49	54.00	-7.51	Average	
2 5210.000	10.32	32.52	30.57	79.09	91.36	-----	-----	Average	
3 5354.672	10.47	32.80	30.61	31.14	43.80	54.00	-10.20	Average	



Unless otherwise agreed in writing, this document is issued by the Company subject to its General Conditions of Service printed overleaf, available on request or accessible at <https://www.sgs.com/en/Terms-and-Conditions>. Attention is drawn to the limitation of liability, indemnification and jurisdiction issues defined therein. Any holder of this document is advised that information contained hereon reflects the Company's findings at the time of its intervention only and within the limits of Client's instructions, if any. The Company's sole responsibility is to its Client and this document does not exonerate parties to a transaction from exercising all their rights and obligations under the transaction documents. This document cannot be reproduced except in full, without prior written approval of the Company. Any unauthorized alteration, forgery or falsification of the content or appearance of this document is unlawful and offenders may be prosecuted to the fullest extent of the law. Unless otherwise stated the results shown in this test report refer only to the sample(s) tested and such sample(s) are retained for 30 days only.

Attention: To check the authenticity of testing /inspection report & certificate, please contact us at telephone: (86-755) 8307 1443, or email: CN.Doccheck@sgs.com
 No.1 Workshop, M-10, Middle Section, Science & Technology Park, Nanshan District, Shenzhen, Guangdong, China 518057 t (86-755) 26012053 f (86-755) 26710594 www.sgs.com.cn
 中国·广东·深圳市南山区科技园中区M-10栋1号厂房 邮编: 518057 t (86-755) 26012053 f (86-755) 26710594 sgs.china@sgs.com

11a_TX_CH_64_Horizontal-Peak

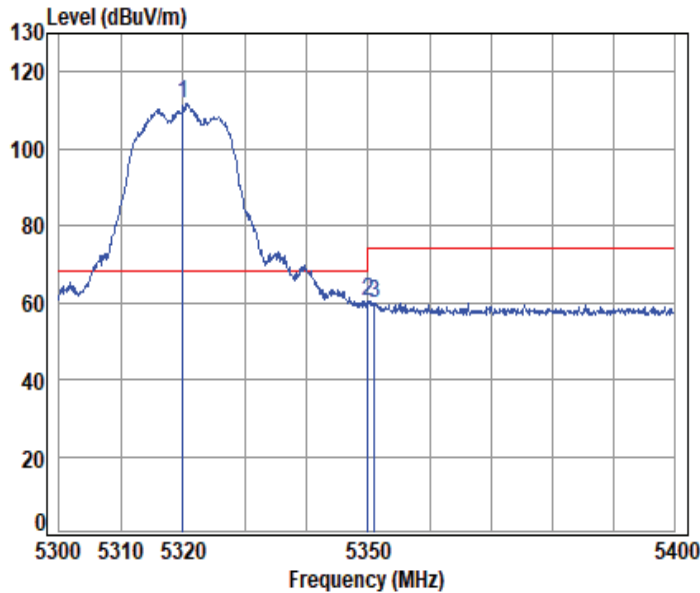

Condition: 3m HORIZONTAL

Job No : 01607WM

Mode : 5320 Band edge

: 5G Wi-Fi 11a

	Cable	Ant	Preamp	Read	Limit	Over			
Freq	Loss	Factor	Factor	Level	Level	Line	Limit	Remark	
MHz	dB	dB/m	dB	dBuV	dBuV/m	dBuV/m	dB		
1 pp 5320.000	10.35	32.74	30.60	99.04	111.53	68.20	43.33	peak	
2 5350.020	10.45	32.80	30.61	47.69	60.33	74.00	-13.67	peak	
3 5351.066	10.45	32.80	30.61	47.36	60.00	74.00	-14.00	peak	



Unless otherwise agreed in writing, this document is issued by the Company subject to its General Conditions of Service printed overleaf, available on request or accessible at <https://www.sgs.com/en/Terms-and-Conditions>. Attention is drawn to the limitation of liability, indemnification and jurisdiction issues defined therein. Any holder of this document is advised that information contained hereon reflects the Company's findings at the time of its intervention only and within the limits of Client's instructions, if any. The Company's sole responsibility is to its Client and this document does not exonerate parties to a transaction from exercising all their rights and obligations under the transaction documents. This document cannot be reproduced except in full, without prior written approval of the Company. Any unauthorized alteration, forgery or falsification of the content or appearance of this document is unlawful and offenders may be prosecuted to the fullest extent of the law. Unless otherwise stated the results shown in this test report refer only to the sample(s) tested and such sample(s) are retained for 30 days only.

Attention: To check the authenticity of testing /inspection report & certificate, please contact us at telephone: (86-755) 8307 1443, or email: CN.Doccheck@sgs.com
 No.1 Workshop, M-10, Middle Section, Science & Technology Park, Nanshan District, Shenzhen, Guangdong, China 518057 t (86-755) 26012053 f (86-755) 26710594 www.sgs.com.cn
 中国·广东·深圳市南山区科技园中区M-10栋1号厂房 邮编: 518057 t (86-755) 26012053 f (86-755) 26710594 sgs.china@sgs.com

11a_TX_CH_64_Horizontal-Avg

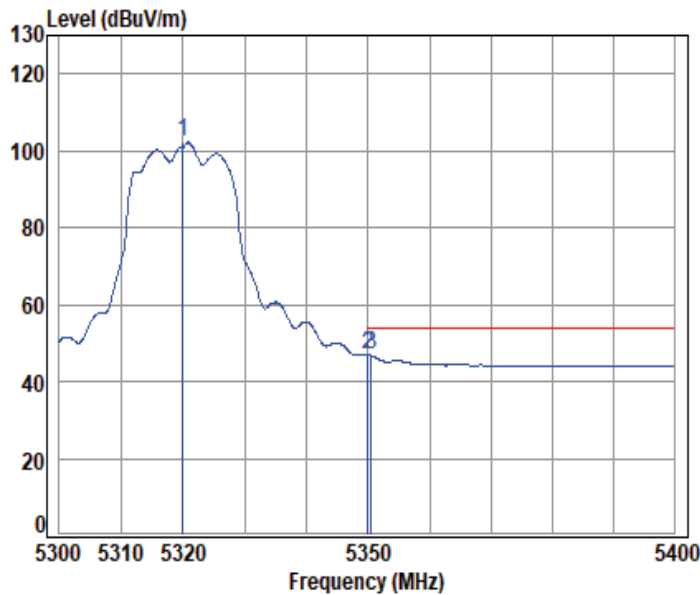

Condition: 3m HORIZONTAL

Job No : 01607WM

Mode : 5320 Band edge

: 5G Wi-Fi 11a

	Cable	Ant	Preamp	Read	Limit	Over		
Freq	Loss	Factor	Factor	Level	Level	Line	Limit	Remark
MHz	dB	dB/m	dB	dBuV	dBuV/m	dBuV/m	dB	
1	5320.000	10.35	32.74	30.60	89.60	102.09	-----	----- Average
2	pp 5350.020	10.45	32.80	30.61	34.40	47.04	54.00	-6.96 Average
3	5350.566	10.45	32.80	30.61	34.12	46.76	54.00	-7.24 Average



Unless otherwise agreed in writing, this document is issued by the Company subject to its General Conditions of Service printed overleaf, available on request or accessible at <https://www.sgs.com/en/Terms-and-Conditions>. Attention is drawn to the limitation of liability, indemnification and jurisdiction issues defined therein. Any holder of this document is advised that information contained hereon reflects the Company's findings at the time of its intervention only and within the limits of Client's instructions, if any. The Company's sole responsibility is to its Client and this document does not exonerate parties to a transaction from exercising all their rights and obligations under the transaction documents. This document cannot be reproduced except in full, without prior written approval of the Company. Any unauthorized alteration, forgery or falsification of the content or appearance of this document is unlawful and offenders may be prosecuted to the fullest extent of the law. Unless otherwise stated the results shown in this test report refer only to the sample(s) tested and such sample(s) are retained for 30 days only.

Attention: To check the authenticity of testing /inspection report & certificate, please contact us at telephone: (86-755) 8307 1443, or email: CN.Doccheck@sgs.com
 No.1 Workshop, M-10, Middle Section, Science & Technology Park, Nanshan District, Shenzhen, Guangdong, China 518057 t (86-755) 26012053 f (86-755) 26710594 www.sgs.com.cn
 中国·广东·深圳市南山区科技园中区M-10栋1号厂房 邮编: 518057 t (86-755) 26012053 f (86-755) 26710594 sgs.china@sgs.com

11a_TX_CH_64_Verical-Peak

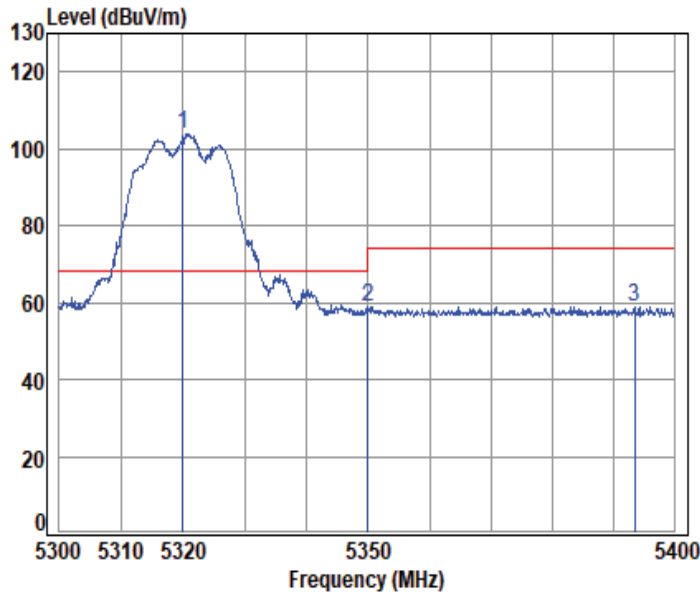

Condition: 3m VERTICAL

Job No : 01607WM

Mode : 5320 Band edge

: 5G Wi-Fi 11a

	Cable	Ant	Preamp	Read	Limit	Over		
Freq	Loss	Factor	Factor	Level	Level	Line	Limit	Remark
MHz	dB	dB/m	dB	dBuV	dBuV/m	dBuV/m	dB	
1 pp 5320.000	10.35	32.74	30.60	91.51	104.00	68.20	35.80	peak
2 5350.020	10.45	32.80	30.61	46.08	58.72	74.00	-15.28	peak
3 5393.544	10.60	32.80	30.62	46.16	58.94	74.00	-15.06	peak



Unless otherwise agreed in writing, this document is issued by the Company subject to its General Conditions of Service printed overleaf, available on request or accessible at <https://www.sgs.com/en/Terms-and-Conditions>. Attention is drawn to the limitation of liability, indemnification and jurisdiction issues defined therein. Any holder of this document is advised that information contained hereon reflects the Company's findings at the time of its intervention only and within the limits of Client's instructions, if any. The Company's sole responsibility is to its Client and this document does not exonerate parties to a transaction from exercising all their rights and obligations under the transaction documents. This document cannot be reproduced except in full, without prior written approval of the Company. Any unauthorized alteration, forgery or falsification of the content or appearance of this document is unlawful and offenders may be prosecuted to the fullest extent of the law. Unless otherwise stated the results shown in this test report refer only to the sample(s) tested and such sample(s) are retained for 30 days only.

Attention: To check the authenticity of testing /inspection report & certificate, please contact us at telephone: (86-755) 8307 1443, or email: CN.Doccheck@sgs.com
 No.1 Workshop, M-10, Middle Section, Science & Technology Park, Nanshan District, Shenzhen, Guangdong, China 518057 t (86-755) 26012053 f (86-755) 26710594 www.sgs.com.cn
 中国·广东·深圳市南山区科技园中区M-10栋1号厂房 邮编: 518057 t (86-755) 26012053 f (86-755) 26710594 sgs.china@sgs.com

11a_TX_CH_64_Vertical-Avg

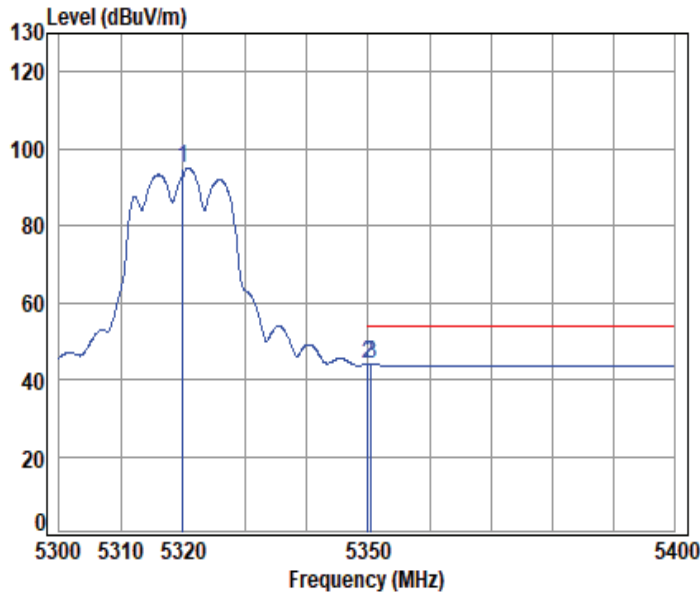

Condition: 3m VERTICAL

Job No : 01607WM

Mode : 5320 Band edge

: 5G Wi-Fi 11a

	Cable	Ant	Preamp	Read	Limit	Over		
Freq	Loss	Factor	Factor	Level	Level	Line	Limit	Remark
MHz	dB	dB/m	dB	dBuV	dBuV/m	dBuV/m	dB	
1	5320.000	10.35	32.74	30.60	82.50	94.99	-----	----- Average
2	pp 5350.020	10.45	32.80	30.61	31.43	44.07	54.00	-9.93 Average
3	5350.566	10.45	32.80	30.61	31.43	44.07	54.00	-9.93 Average



Unless otherwise agreed in writing, this document is issued by the Company subject to its General Conditions of Service printed overleaf, available on request or accessible at <https://www.sgs.com/en/Terms-and-Conditions>. Attention is drawn to the limitation of liability, indemnification and jurisdiction issues defined therein. Any holder of this document is advised that information contained hereon reflects the Company's findings at the time of its intervention only and within the limits of Client's instructions, if any. The Company's sole responsibility is to its Client and this document does not exonerate parties to a transaction from exercising all their rights and obligations under the transaction documents. This document cannot be reproduced except in full, without prior written approval of the Company. Any unauthorized alteration, forgery or falsification of the content or appearance of this document is unlawful and offenders may be prosecuted to the fullest extent of the law. Unless otherwise stated the results shown in this test report refer only to the sample(s) tested and such sample(s) are retained for 30 days only.

Attention: To check the authenticity of testing /inspection report & certificate, please contact us at telephone: (86-755) 8307 1443, or email: CN.Doccheck@sgs.com
 No.1 Workshop, M-10, Middle Section, Science & Technology Park, Nanshan District, Shenzhen, Guangdong, China 518057 t (86-755) 26012053 f (86-755) 26710594 www.sgsgroup.com.cn
 中国·广东·深圳市南山区科技园中区M-10栋1号厂房 邮编: 518057 t (86-755) 26012053 f (86-755) 26710594 sgs.china@sgs.com

11ac_VHT(20M)_TX_CH_64_Horizontal-Peak

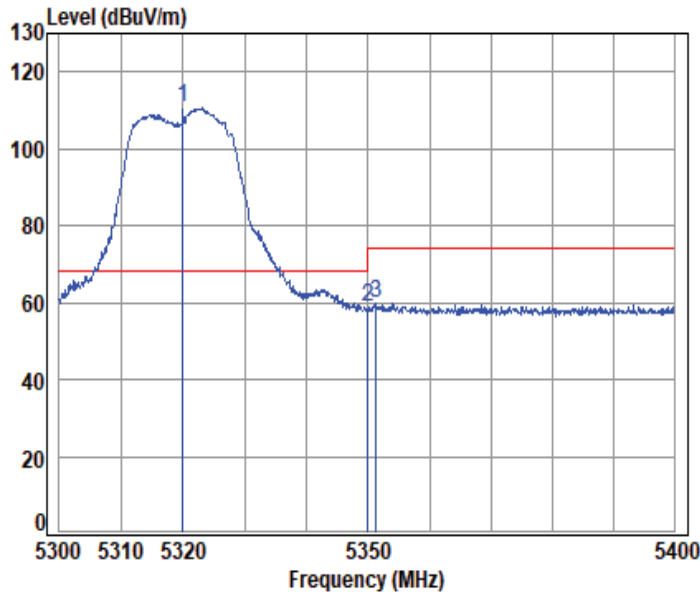

Condition: 3m HORIZONTAL

Job No : 01607WM

Mode : 5320 Band edge

: 5G Wi-Fi 11ac20

	Cable	Ant	Preamp	Read	Limit	Over		
Freq	Loss	Factor	Factor	Level	Level	Line	Limit	Remark
MHz	dB	dB/m	dB	dBuV	dBuV/m	dBuV/m	dB	
1 pp 5320.000	10.35	32.74	30.60	98.16	110.65	68.20	42.45	peak
2 5350.020	10.45	32.80	30.61	46.07	58.71	74.00	-15.29	peak
3 5351.267	10.45	32.80	30.61	47.19	59.83	74.00	-14.17	peak



Unless otherwise agreed in writing, this document is issued by the Company subject to its General Conditions of Service printed overleaf, available on request or accessible at <https://www.sgs.com/en/Terms-and-Conditions>. Attention is drawn to the limitation of liability, indemnification and jurisdiction issues defined therein. Any holder of this document is advised that information contained hereon reflects the Company's findings at the time of its intervention only and within the limits of Client's instructions, if any. The Company's sole responsibility is to its Client and this document does not exonerate parties to a transaction from exercising all their rights and obligations under the transaction documents. This document cannot be reproduced except in full, without prior written approval of the Company. Any unauthorized alteration, forgery or falsification of the content or appearance of this document is unlawful and offenders may be prosecuted to the fullest extent of the law. Unless otherwise stated the results shown in this test report refer only to the sample(s) tested and such sample(s) are retained for 30 days only.

Attention: To check the authenticity of testing /inspection report & certificate, please contact us at telephone: (86-755) 8307 1443, or email: CN.Doccheck@sgs.com
 No.1 Workshop, M-10, Middle Section, Science & Technology Park, Nanshan District, Shenzhen, Guangdong, China 518057 t (86-755) 26012053 f (86-755) 26710594 www.sgs.com.cn
 中国·广东·深圳市南山区科技园中区M-10栋1号厂房 邮编: 518057 t (86-755) 26012053 f (86-755) 26710594 sgs.china@sgs.com

11ac_VHT(20M)_TX_CH_64_Horizontal-Avg

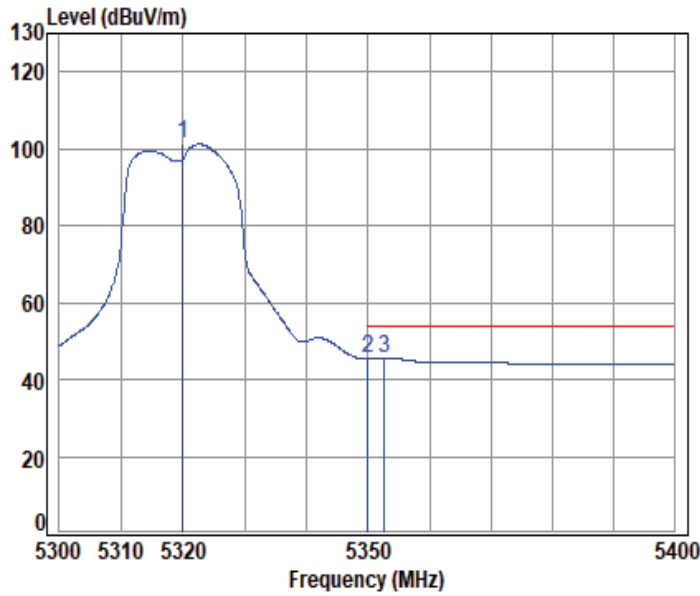

Condition: 3m HORIZONTAL

Job No : 01607WM

Mode : 5320 Band edge

: 5G Wi-Fi 11ac20

	Cable	Ant	Preamp	Read	Limit	Over		
Freq	Loss	Factor	Factor	Level	Level	Line	Limit	Remark
MHz	dB	dB/m	dB	dBuV	dBuV/m	dBuV/m	dB	
1	5320.000	10.35	32.74	30.60	88.66	101.15	-----	----- Average
2	5350.020	10.45	32.80	30.61	32.79	45.43	54.00	-8.57 Average
3	pp 5352.667	10.46	32.80	30.61	33.06	45.71	54.00	-8.29 Average



Unless otherwise agreed in writing, this document is issued by the Company subject to its General Conditions of Service printed overleaf, available on request or accessible at <https://www.sgs.com/en/Terms-and-Conditions>. Attention is drawn to the limitation of liability, indemnification and jurisdiction issues defined therein. Any holder of this document is advised that information contained hereon reflects the Company's findings at the time of its intervention only and within the limits of Client's instructions, if any. The Company's sole responsibility is to its Client and this document does not exonerate parties to a transaction from exercising all their rights and obligations under the transaction documents. This document cannot be reproduced except in full, without prior written approval of the Company. Any unauthorized alteration, forgery or falsification of the content or appearance of this document is unlawful and offenders may be prosecuted to the fullest extent of the law. Unless otherwise stated the results shown in this test report refer only to the sample(s) tested and such sample(s) are retained for 30 days only.

11ac_VHT(20M)_TX_CH_64_Vertical-Peak

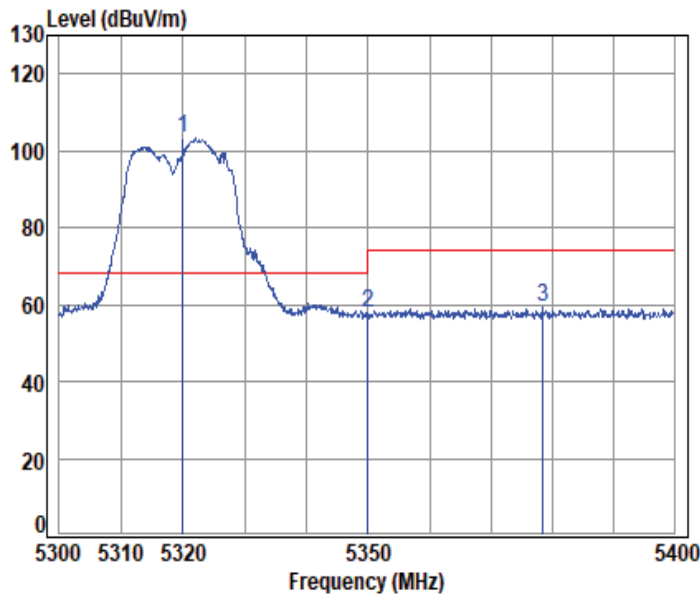

Condition: 3m VERTICAL

Job No : 01607WM

Mode : 5320 Band edge

: 5G Wi-Fi 11ac20

	Cable	Ant	Preamp	Read	Limit	Over			
Freq	Loss	Factor	Factor	Level	Level	Line	Limit	Remark	
MHz	dB	dB/m	dB	dBuV	dBuV/m	dBuV/m	dB		
1 pp 5320.000	10.35	32.74	30.60	90.67	103.16	68.20	34.96	peak	
2 5350.020	10.45	32.80	30.61	44.98	57.62	74.00	-16.38	peak	
3 5378.543	10.55	32.80	30.62	46.37	59.10	74.00	-14.90	peak	



11ac_VHT(20M)_TX_CH_64_Vertical-Avg

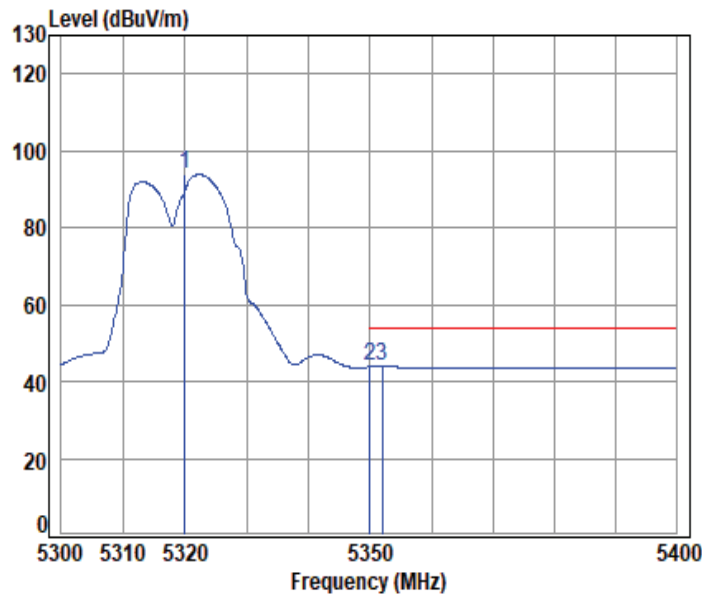

Condition: 3m VERTICAL

Job No : 01607WM

Mode : 5320 Band edge

: 5G Wi-Fi 11ac20

	Cable	Ant	Preamp	Read	Limit	Over		
Freq	Loss	Factor	Factor	Level	Level	Line	Limit	Remark
MHz	dB	dB/m	dB	dBuV	dBuV/m	dBuV/m	dB	
1	5320.000	10.35	32.74	30.60	81.31	93.80	-----	----- Average
2	5350.020	10.45	32.80	30.61	31.20	43.84	54.00	-10.16 Average
3	pp 5351.967	10.46	32.80	30.61	31.27	43.92	54.00	-10.08 Average



Unless otherwise agreed in writing, this document is issued by the Company subject to its General Conditions of Service printed overleaf, available on request or accessible at <https://www.sgs.com/en/Terms-and-Conditions>. Attention is drawn to the limitation of liability, indemnification and jurisdiction issues defined therein. Any holder of this document is advised that information contained hereon reflects the Company's findings at the time of its intervention only and within the limits of Client's instructions, if any. The Company's sole responsibility is to its Client and this document does not exonerate parties to a transaction from exercising all their rights and obligations under the transaction documents. This document cannot be reproduced except in full, without prior written approval of the Company. Any unauthorized alteration, forgery or falsification of the content or appearance of this document is unlawful and offenders may be prosecuted to the fullest extent of the law. Unless otherwise stated the results shown in this test report refer only to the sample(s) tested and such sample(s) are retained for 30 days only.

Attention: To check the authenticity of testing /inspection report & certificate, please contact us at telephone: (86-755) 8307 1443, or email: CN.Doccheck@sgs.com
 No.1 Workshop, M-10, Middle Section, Science & Technology Park, Nanshan District, Shenzhen, Guangdong, China 518057 t (86-755) 26012053 f (86-755) 26710594 www.sgs.com.cn
 中国·广东·深圳市南山区科技园中区M-10栋1号厂房 邮编: 518057 t (86-755) 26012053 f (86-755) 26710594 sgs.china@sgs.com

11ac_VHT(40M)_TX_CH_62_Horizontal-Peak

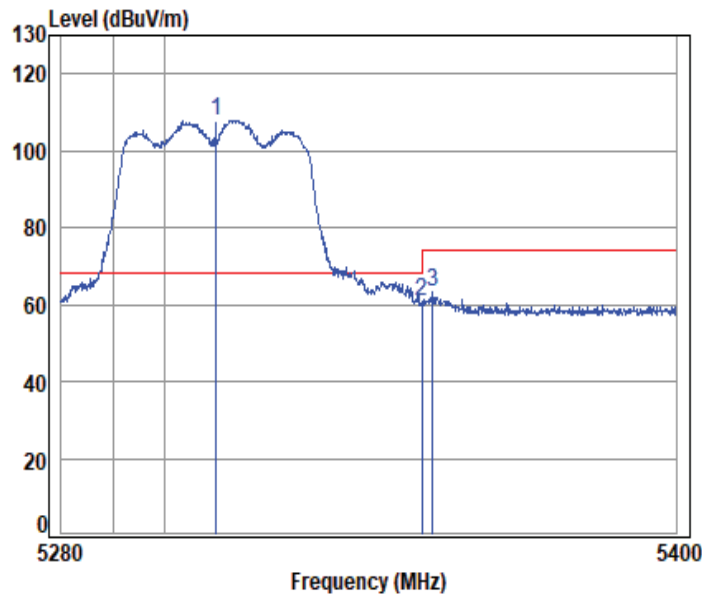

Condition: 3m HORIZONTAL

Job No : 01607WM

Mode : 5310 Band edge

: 5G Wi-Fi 11ac40

	Cable	Ant	Preamp	Read	Limit	Over			
Freq	Loss	Factor	Factor	Level	Level	Line	Limit	Remark	
MHz	dB	dB/m	dB	dBuV	dBuV/m	dBuV/m	dB		
1 pp 5310.000	10.31	32.72	30.60	95.56	107.99	68.20	39.79	peak	
2 5350.020	10.45	32.80	30.61	47.98	60.62	74.00	-13.38	peak	
3 5352.157	10.46	32.80	30.61	50.42	63.07	74.00	-10.93	peak	



Unless otherwise agreed in writing, this document is issued by the Company subject to its General Conditions of Service printed overleaf, available on request or accessible at <https://www.sgs.com/en/Terms-and-Conditions>. Attention is drawn to the limitation of liability, indemnification and jurisdiction issues defined therein. Any holder of this document is advised that information contained hereon reflects the Company's findings at the time of its intervention only and within the limits of Client's instructions, if any. The Company's sole responsibility is to its Client and this document does not exonerate parties to a transaction from exercising all their rights and obligations under the transaction documents. This document cannot be reproduced except in full, without prior written approval of the Company. Any unauthorized alteration, forgery or falsification of the content or appearance of this document is unlawful and offenders may be prosecuted to the fullest extent of the law. Unless otherwise stated the results shown in this test report refer only to the sample(s) tested and such sample(s) are retained for 30 days only.

Attention: To check the authenticity of testing /inspection report & certificate, please contact us at telephone: (86-755) 8307 1443, or email: CN.Doccheck@sgs.com
 No.1 Workshop, M-10, Middle Section, Science & Technology Park, Nanshan District, Shenzhen, Guangdong, China 518057 t (86-755) 26012053 f (86-755) 26710594 www.sgs.com.cn
 中国·广东·深圳市南山区科技园中区M-10栋1号厂房 邮编: 518057 t (86-755) 26012053 f (86-755) 26710594 sgs.china@sgs.com

11ac_VHT(40M)_TX_CH_62_Horizontal-Avg

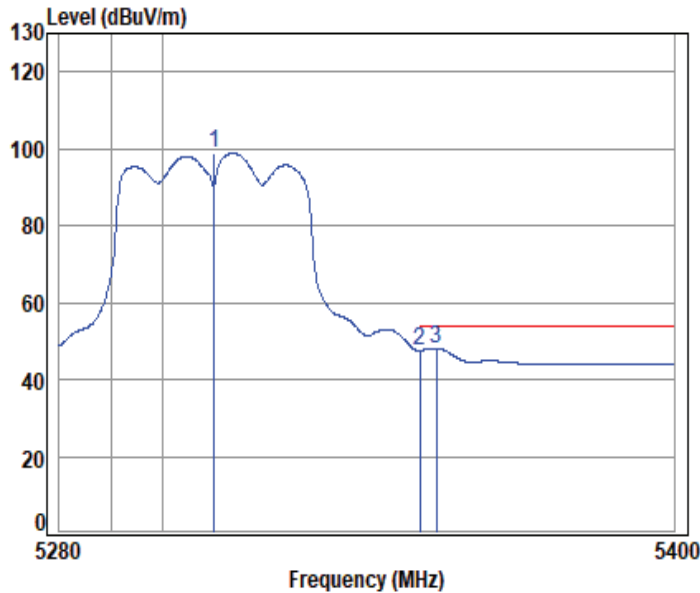

Condition: 3m HORIZONTAL

Job No : 01607WM

Mode : 5310 Band edge

: 5G Wi-Fi 11ac40

	Cable	Ant	Preamp	Read	Limit	Over		
Freq	Loss	Factor	Factor	Level	Level	Line	Limit	Remark
MHz	dB	dB/m	dB	dBuV	dBuV/m	dBuV/m	dB	
1	5310.000	10.31	32.72	30.60	86.37	98.80	-----	----- Average
2	5350.020	10.45	32.80	30.61	34.89	47.53	54.00	-6.47 Average
3	pp 5353.360	10.46	32.80	30.61	35.48	48.13	54.00	-5.87 Average



Unless otherwise agreed in writing, this document is issued by the Company subject to its General Conditions of Service printed overleaf, available on request or accessible at <https://www.sgs.com/en/Terms-and-Conditions>. Attention is drawn to the limitation of liability, indemnification and jurisdiction issues defined therein. Any holder of this document is advised that information contained hereon reflects the Company's findings at the time of its intervention only and within the limits of Client's instructions, if any. The Company's sole responsibility is to its Client and this document does not exonerate parties to a transaction from exercising all their rights and obligations under the transaction documents. This document cannot be reproduced except in full, without prior written approval of the Company. Any unauthorized alteration, forgery or falsification of the content or appearance of this document is unlawful and offenders may be prosecuted to the fullest extent of the law. Unless otherwise stated the results shown in this test report refer only to the sample(s) tested and such sample(s) are retained for 30 days only.

Attention: To check the authenticity of testing /inspection report & certificate, please contact us at telephone: (86-755) 8307 1443, or email: CN.Doccheck@sgs.com
 No.1 Workshop, M-10, Middle Section, Science & Technology Park, Nanshan District, Shenzhen, Guangdong, China 518057 t (86-755) 26012053 f (86-755) 26710594 www.sgs.com.cn
 中国·广东·深圳市南山区科技园中区M-10栋1号厂房 邮编: 518057 t (86-755) 26012053 f (86-755) 26710594 sgs.china@sgs.com

11ac_VHT(40M)_TX_CH_62_Vertical-Peak

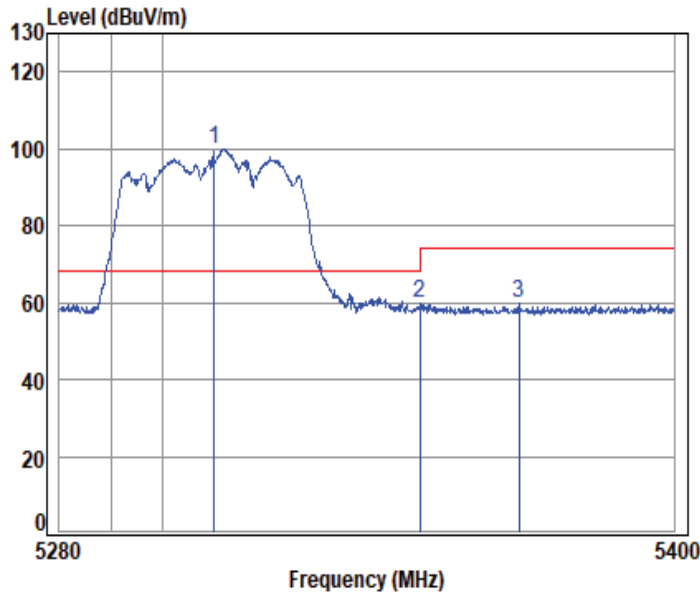

Condition: 3m VERTICAL

Job No : 01607WM

Mode : 5310 Band edge

: 5G Wi-Fi 11ac40

	Cable	Ant	Preamp	Read	Limit	Over			
Freq	Loss	Factor	Factor	Level	Level	Line	Limit	Remark	
MHz	dB	dB/m	dB	dBuV	dBuV/m	dBuV/m	dB		
1 pp 5310.000	10.31	32.72	30.60	87.27	99.70	68.20	31.50	peak	
2 5350.020	10.45	32.80	30.61	47.00	59.64	74.00	-14.36	peak	
3 5369.505	10.52	32.80	30.62	46.92	59.62	74.00	-14.38	peak	



Unless otherwise agreed in writing, this document is issued by the Company subject to its General Conditions of Service printed overleaf, available on request or accessible at <https://www.sgs.com/en/Terms-and-Conditions>. Attention is drawn to the limitation of liability, indemnification and jurisdiction issues defined therein. Any holder of this document is advised that information contained hereon reflects the Company's findings at the time of its intervention only and within the limits of Client's instructions, if any. The Company's sole responsibility is to its Client and this document does not exonerate parties to a transaction from exercising all their rights and obligations under the transaction documents. This document cannot be reproduced except in full, without prior written approval of the Company. Any unauthorized alteration, forgery or falsification of the content or appearance of this document is unlawful and offenders may be prosecuted to the fullest extent of the law. Unless otherwise stated the results shown in this test report refer only to the sample(s) tested and such sample(s) are retained for 30 days only.

Attention: To check the authenticity of testing /inspection report & certificate, please contact us at telephone: (86-755) 8307 1443, or email: CN.Doccheck@sgs.com
 No.1 Workshop, M-10, Middle Section, Science & Technology Park, Nanshan District, Shenzhen, Guangdong, China 518057 t (86-755) 26012053 f (86-755) 26710594 www.sgs.com.cn
 中国·广东·深圳市南山区科技园中区M-10栋1号厂房 邮编: 518057 t (86-755) 26012053 f (86-755) 26710594 sgs.china@sgs.com

11ac_VHT(40M)_TX_CH_62_Vertical-Avg

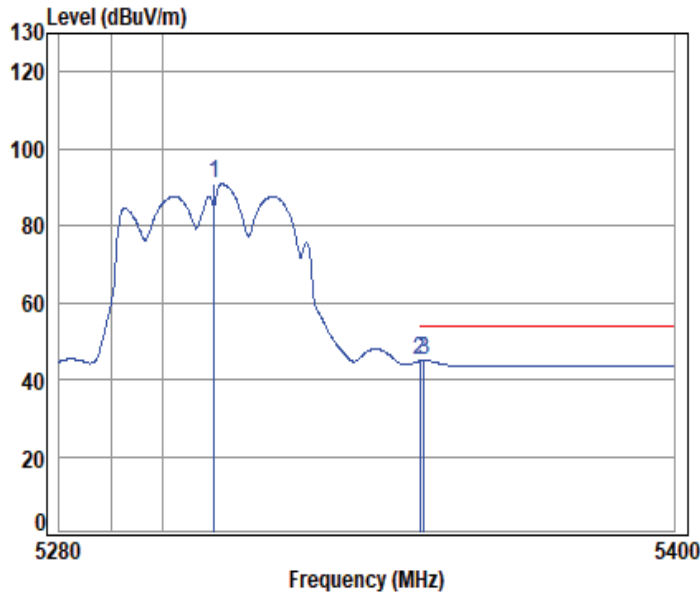

Condition: 3m VERTICAL

Job No : 01607WM

Mode : 5310 Band edge

: 5G Wi-Fi 11ac40

	Cable	Ant	Preamp	Read	Limit	Over		
Freq	Loss	Factor	Factor	Level	Level	Line	Limit	Remark
MHz	dB	dB/m	dB	dBuV	dBuV/m	dBuV/m	dB	
1	5310.000	10.31	32.72	30.60	78.32	90.75	-----	----- Average
2	5350.020	10.45	32.80	30.61	32.18	44.82	54.00	-9.18 Average
3 pp	5350.955	10.45	32.80	30.61	32.24	44.88	54.00	-9.12 Average



Unless otherwise agreed in writing, this document is issued by the Company subject to its General Conditions of Service printed overleaf, available on request or accessible at <https://www.sgs.com/en/Terms-and-Conditions>. Attention is drawn to the limitation of liability, indemnification and jurisdiction issues defined therein. Any holder of this document is advised that information contained hereon reflects the Company's findings at the time of its intervention only and within the limits of Client's instructions, if any. The Company's sole responsibility is to its Client and this document does not exonerate parties to a transaction from exercising all their rights and obligations under the transaction documents. This document cannot be reproduced except in full, without prior written approval of the Company. Any unauthorized alteration, forgery or falsification of the content or appearance of this document is unlawful and offenders may be prosecuted to the fullest extent of the law. Unless otherwise stated the results shown in this test report refer only to the sample(s) tested and such sample(s) are retained for 30 days only.

Attention: To check the authenticity of testing /inspection report & certificate, please contact us at telephone: (86-755) 8307 1443, or email: CN.Doccheck@sgs.com
 No.1 Workshop, M-10, Middle Section, Science & Technology Park, Nanshan District, Shenzhen, Guangdong, China 518057 t (86-755) 26012053 f (86-755) 26710594 www.sgs.com.cn
 中国·广东·深圳市南山区科技园中区M-10栋1号厂房 邮编: 518057 t (86-755) 26012053 f (86-755) 26710594 sgs.china@sgs.com

11ac_VHT(80M)_TX_CH_58_Horizontal-Peak

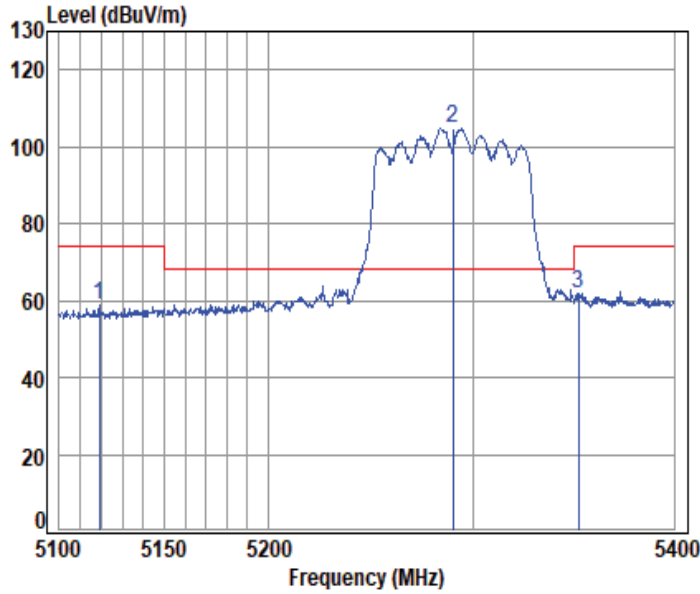

Condition: 3m HORIZONTAL

Job No : 01607WM

Mode : 5290 Band edge

: 5G Wi-Fi 11ac80

	Cable	Ant	Preamp	Read	Limit	Over			
Freq	Loss	Factor	Factor	Level	Level	Line	Limit	Remark	
MHz	dB	dB/m	dB	dBuV	dBuV/m	dBuV/m	dB		
1	5118.983	10.02	32.34	30.54	46.95	58.77	74.00	-15.23 peak	
2	pp 5290.000	10.28	32.68	30.59	92.64	105.01	68.20	36.81 peak	
3	5352.064	10.46	32.80	30.61	49.30	61.95	74.00	-12.05 peak	



Unless otherwise agreed in writing, this document is issued by the Company subject to its General Conditions of Service printed overleaf, available on request or accessible at <https://www.sgs.com/en/Terms-and-Conditions>. Attention is drawn to the limitation of liability, indemnification and jurisdiction issues defined therein. Any holder of this document is advised that information contained hereon reflects the Company's findings at the time of its intervention only and within the limits of Client's instructions, if any. The Company's sole responsibility is to its Client and this document does not exonerate parties to a transaction from exercising all their rights and obligations under the transaction documents. This document cannot be reproduced except in full, without prior written approval of the Company. Any unauthorized alteration, forgery or falsification of the content or appearance of this document is unlawful and offenders may be prosecuted to the fullest extent of the law. Unless otherwise stated the results shown in this test report refer only to the sample(s) tested and such sample(s) are retained for 30 days only.

Attention: To check the authenticity of testing /inspection report & certificate, please contact us at telephone: (86-755) 8307 1443, or email: CN.Doccheck@sgs.com
 No.1 Workshop, M-10, Middle Section, Science & Technology Park, Nanshan District, Shenzhen, Guangdong, China 518057 t (86-755) 26012053 f (86-755) 26710594 www.sgs.com.cn
 中国·广东·深圳市南山区科技园中区M-10栋1号厂房 邮编: 518057 t (86-755) 26012053 f (86-755) 26710594 sgs.china@sgs.com

11ac_VHT(80M)_TX_CH_58_Horizontal-Avg

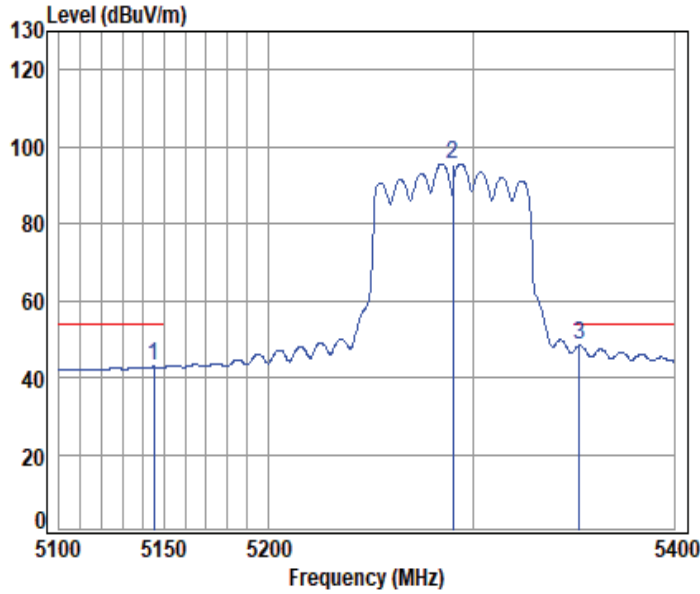

Condition: 3m HORIZONTAL

Job No : 01607WM

Mode : 5290 Band edge

: 5G Wi-Fi 11ac80

	Cable	Ant	Preamp	Read	Limit	Over			
Freq	Loss	Factor	Factor	Level	Level	Line	Limit	Remark	
MHz	dB	dB/m	dB	dBuV	dBuV/m	dBuV/m	dB		
1	5145.090	10.12	32.39	30.55	30.82	42.78	54.00	-11.22	Average
2	5290.000	10.28	32.68	30.59	83.22	95.59	-----	-----	Average
3	pp 5352.676	10.46	32.80	30.61	35.72	48.37	54.00	-5.63	Average



Unless otherwise agreed in writing, this document is issued by the Company subject to its General Conditions of Service printed overleaf, available on request or accessible at <https://www.sgs.com/en/Terms-and-Conditions>. Attention is drawn to the limitation of liability, indemnification and jurisdiction issues defined therein. Any holder of this document is advised that information contained hereon reflects the Company's findings at the time of its intervention only and within the limits of Client's instructions, if any. The Company's sole responsibility is to its Client and this document does not exonerate parties to a transaction from exercising all their rights and obligations under the transaction documents. This document cannot be reproduced except in full, without prior written approval of the Company. Any unauthorized alteration, forgery or falsification of the content or appearance of this document is unlawful and offenders may be prosecuted to the fullest extent of the law. Unless otherwise stated the results shown in this test report refer only to the sample(s) tested and such sample(s) are retained for 30 days only.

Attention: To check the authenticity of testing /inspection report & certificate, please contact us at telephone: (86-755) 8307 1443, or email: CN.Doccheck@sgs.com
 No.1 Workshop, M-10, Middle Section, Science & Technology Park, Nanshan District, Shenzhen, Guangdong, China 518057 t (86-755) 26012053 f (86-755) 26710594 www.sgs.com.cn
 中国·广东·深圳市南山区科技园中区M-10栋1号厂房 邮编: 518057 t (86-755) 26012053 f (86-755) 26710594 sgs.china@sgs.com

11ac_VHT(80M)_TX_CH_58_Vertical-Peak

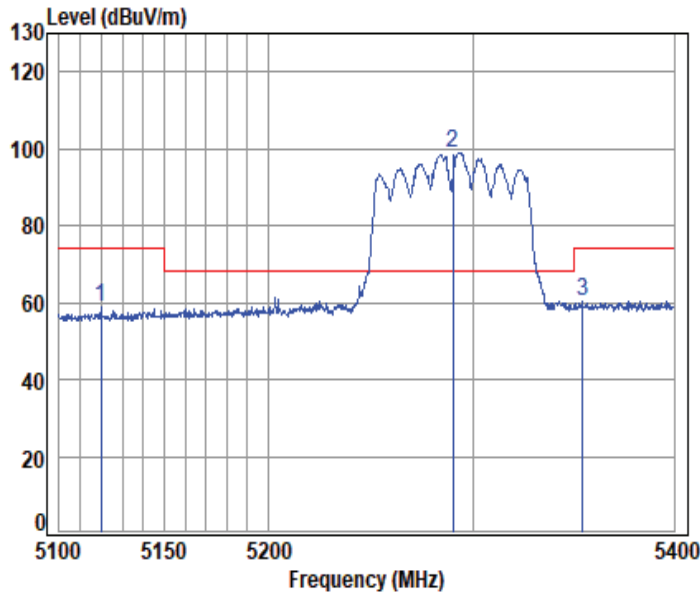

Condition: 3m VERTICAL

Job No : 01607WM

Mode : 5290 Band edge

: 5G Wi-Fi 11ac80

	Cable	Ant	Preamp	Read	Limit	Over			
Freq	Loss	Factor	Factor	Level	Level	Line	Limit	Remark	
MHz	dB	dB/m	dB	dBuV	dBuV/m	dBuV/m	dB		
1	5119.861	10.03	32.34	30.54	46.94	58.77	74.00	-15.23 peak	
2	pp 5290.000	10.28	32.68	30.59	86.50	98.87	68.20	30.67 peak	
3	5354.206	10.46	32.80	30.61	47.41	60.06	74.00	-13.94 peak	



Unless otherwise agreed in writing, this document is issued by the Company subject to its General Conditions of Service printed overleaf, available on request or accessible at <https://www.sgs.com/en/Terms-and-Conditions>. Attention is drawn to the limitation of liability, indemnification and jurisdiction issues defined therein. Any holder of this document is advised that information contained hereon reflects the Company's findings at the time of its intervention only and within the limits of Client's instructions, if any. The Company's sole responsibility is to its Client and this document does not exonerate parties to a transaction from exercising all their rights and obligations under the transaction documents. This document cannot be reproduced except in full, without prior written approval of the Company. Any unauthorized alteration, forgery or falsification of the content or appearance of this document is unlawful and offenders may be prosecuted to the fullest extent of the law. Unless otherwise stated the results shown in this test report refer only to the sample(s) tested and such sample(s) are retained for 30 days only.

Attention: To check the authenticity of testing /inspection report & certificate, please contact us at telephone: (86-755) 8307 1443, or email: CN.Doccheck@sgs.com

11ac_VHT(80M)_TX_CH_58_Vertical-Avg

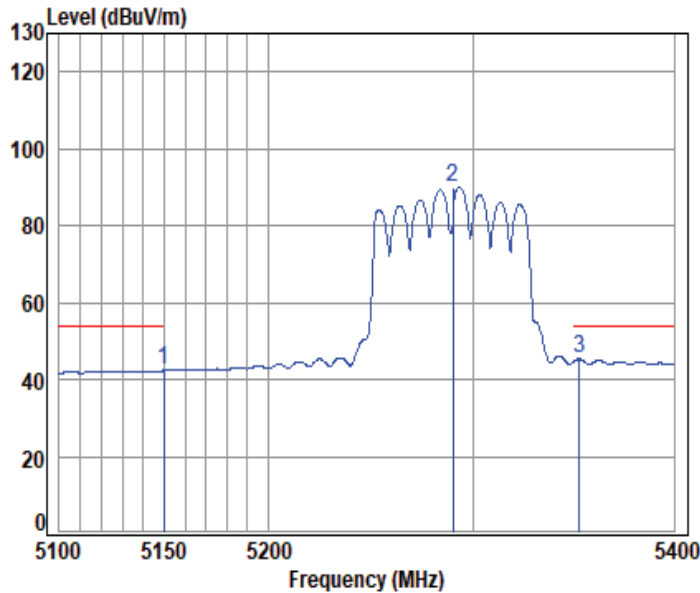

Condition: 3m VERTICAL

Job No : 01607WM

Mode : 5290 Band edge

: 5G Wi-Fi 11ac80

	Cable	Ant	Preamp	Read	Limit	Over			
Freq	Loss	Factor	Factor	Level	Level	Line	Limit	Remark	
MHz	dB	dB/m	dB	dBuV	dBuV/m	dBuV/m	dB		
1	5149.798	10.14	32.40	30.55	30.30	42.29	54.00	-11.71 Average	
2	5290.000	10.28	32.68	30.59	77.58	89.95	-----	----- Average	
3	pp 5352.676	10.46	32.80	30.61	32.71	45.36	54.00	-8.64 Average	



Unless otherwise agreed in writing, this document is issued by the Company subject to its General Conditions of Service printed overleaf, available on request or accessible at <https://www.sgs.com/en/Terms-and-Conditions>. Attention is drawn to the limitation of liability, indemnification and jurisdiction issues defined therein. Any holder of this document is advised that information contained hereon reflects the Company's findings at the time of its intervention only and within the limits of Client's instructions, if any. The Company's sole responsibility is to its Client and this document does not exonerate parties to a transaction from exercising all their rights and obligations under the transaction documents. This document cannot be reproduced except in full, without prior written approval of the Company. Any unauthorized alteration, forgery or falsification of the content or appearance of this document is unlawful and offenders may be prosecuted to the fullest extent of the law. Unless otherwise stated the results shown in this test report refer only to the sample(s) tested and such sample(s) are retained for 30 days only.

Attention: To check the authenticity of testing /inspection report & certificate, please contact us at telephone: (86-755) 8307 1443, or email: CN.Doccheck@sgs.com
 No.1 Workshop, M-10, Middle Section, Science & Technology Park, Nanshan District, Shenzhen, Guangdong, China 518057 t (86-755) 26012053 f (86-755) 26710594 www.sgs.com.cn
 中国·广东·深圳市南山区科技园中区M-10栋1号厂房 邮编: 518057 t (86-755) 26012053 f (86-755) 26710594 sgs.china@sgs.com

11ac_VHT(160M)_TX_CH_50_Horizontal-Peak

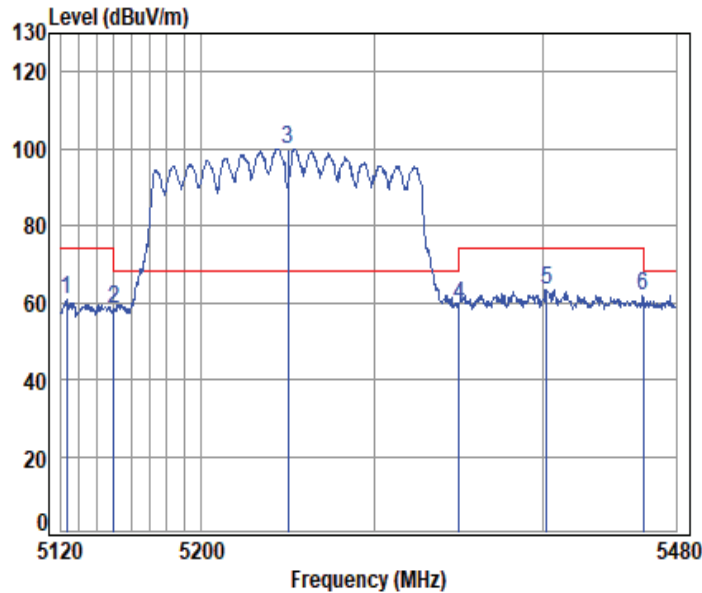

Condition: 3m HORIZONTAL

Job No : 01607WM

Mode : 5250 Band edge

: 5G Wi-Fi 11ac160

	Cable	Ant	Preamp	Read	Limit	Over		
Freq	Loss	Factor	Factor	Level	Level	Line	Limit	Remark
MHz	dB	dB/m	dB	dBuV	dBuV/m	dBuV/m	dB	
1	5123.132	10.04	32.35	30.54	49.09	60.94	74.00	-13.06 peak
2	5149.980	10.14	32.40	30.55	46.52	58.51	74.00	-15.49 peak
3	pp 5250.000	10.31	32.60	30.58	87.66	99.99	68.20	31.79 peak
4	5350.200	10.45	32.80	30.61	46.69	59.33	74.00	-14.67 peak
5	5401.991	10.62	32.80	30.63	50.51	63.30	74.00	-10.70 peak
6	5459.980	10.60	32.90	30.64	48.78	61.64	74.00	-12.36 peak



Unless otherwise agreed in writing, this document is issued by the Company subject to its General Conditions of Service printed overleaf, available on request or accessible at <https://www.sgs.com/en/Terms-and-Conditions>. Attention is drawn to the limitation of liability, indemnification and jurisdiction issues defined therein. Any holder of this document is advised that information contained hereon reflects the Company's findings at the time of its intervention only and within the limits of Client's instructions, if any. The Company's sole responsibility is to its Client and this document does not exonerate parties to a transaction from exercising all their rights and obligations under the transaction documents. This document cannot be reproduced except in full, without prior written approval of the Company. Any unauthorized alteration, forgery or falsification of the content or appearance of this document is unlawful and offenders may be prosecuted to the fullest extent of the law. Unless otherwise stated the results shown in this test report refer only to the sample(s) tested and such sample(s) are retained for 30 days only.

Attention: To check the authenticity of testing /inspection report & certificate, please contact us at telephone: (86-755) 8307 1443, or email: CN.Doccheck@sgs.com
 No.1 Workshop, M-10, Middle Section, Science & Technology Park, Nanshan District, Shenzhen, Guangdong, China 518057 t (86-755) 26012053 f (86-755) 26710594 www.sgsgroup.com.cn
 中国·广东·深圳市南山区科技园中区M-10栋1号厂房 邮编: 518057 t (86-755) 26012053 f (86-755) 26710594 sgs.china@sgs.com

11ac_VHT(160M)_TX_CH_50_Horizontal-Avg

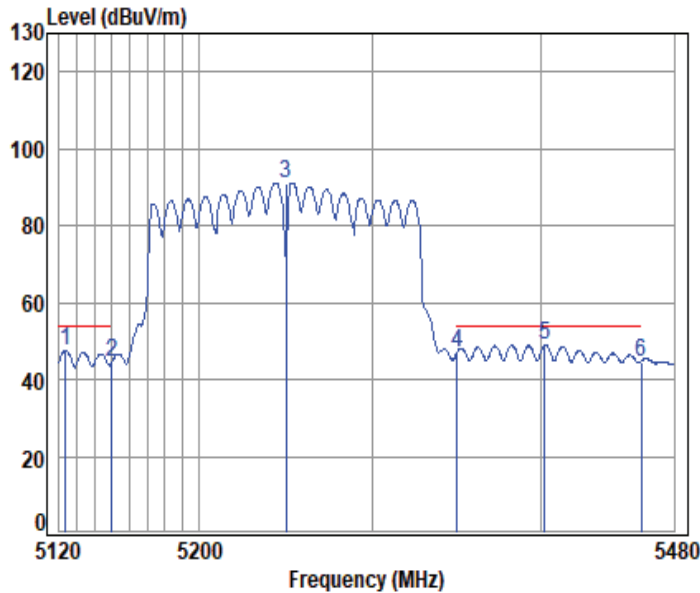

Condition: 3m HORIZONTAL

Job No : 01607WM

Mode : 5250 Band edge

: 5G Wi-Fi 11ac160

	Cable	Ant	Preamp	Read	Limit	Over			
	Freq	Loss	Factor	Factor	Level	Level	Line	Limit	Remark
	MHz	dB	dB/m	dB	dBuV	dBuV/m	dBuV/m	dB	
1	5123.480	10.04	32.35	30.54	35.64	47.49	54.00	-6.51	Average
2	5150.000	10.14	32.40	30.55	32.61	44.60	54.00	-9.40	Average
3	5250.000	10.31	32.60	30.58	78.79	91.12	-----	-----	Average
4	5350.000	10.45	32.80	30.61	34.32	46.96	54.00	-7.04	Average
5	5402.357	10.62	32.80	30.63	36.13	48.92	54.00	-5.08	Average
6	5460.000	10.60	32.90	30.64	31.85	44.71	54.00	-9.29	Average



Unless otherwise agreed in writing, this document is issued by the Company subject to its General Conditions of Service printed overleaf, available on request or accessible at <https://www.sgs.com/en/Terms-and-Conditions>. Attention is drawn to the limitation of liability, indemnification and jurisdiction issues defined therein. Any holder of this document is advised that information contained hereon reflects the Company's findings at the time of its intervention only and within the limits of Client's instructions, if any. The Company's sole responsibility is to its Client and this document does not exonerate parties to a transaction from exercising all their rights and obligations under the transaction documents. This document cannot be reproduced except in full, without prior written approval of the Company. Any unauthorized alteration, forgery or falsification of the content or appearance of this document is unlawful and offenders may be prosecuted to the fullest extent of the law. Unless otherwise stated the results shown in this test report refer only to the sample(s) tested and such sample(s) are retained for 30 days only.

Attention: To check the authenticity of testing /inspection report & certificate, please contact us at telephone: (86-755) 8307 1443, or email: CN.Doccheck@sgs.com
 No.1 Workshop, M-10, Middle Section, Science & Technology Park, Nanshan District, Shenzhen, Guangdong, China 518057 t (86-755) 26012053 f (86-755) 26710594 www.sgs.com.cn
 中国·广东·深圳市南山区科技园中区M-10栋1号厂房 邮编: 518057 t (86-755) 26012053 f (86-755) 26710594 sgs.china@sgs.com

11ac_VHT(160M)_TX_CH_50_Vertical-Peak

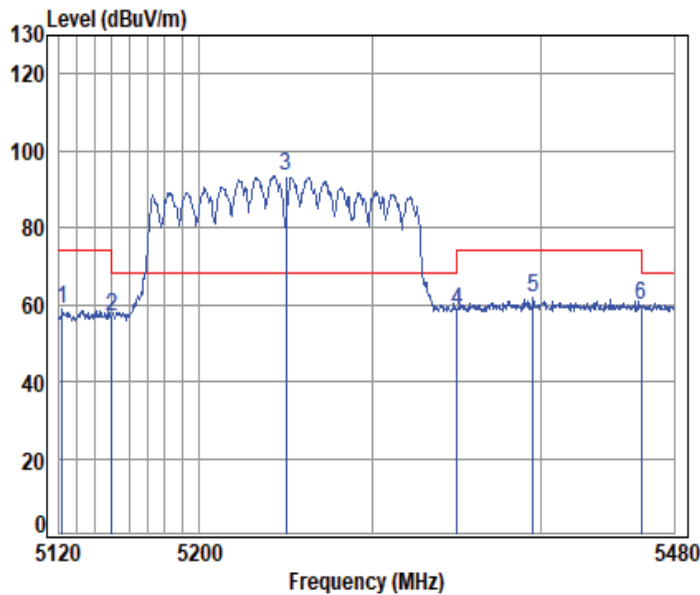

Condition: 3m VERTICAL

Job No : 01607WM

Mode : 5250 Band edge

: 5G Wi-Fi 11ac160

	Cable	Ant	Preamp	Read	Limit	Over			
	Freq	Loss	Factor	Factor	Level	Level	Line	Limit	Remark
	MHz	dB	dB/m	dB	dBuV	dBuV/m	dBuV/m	dB	
1	5121.740	10.03	32.34	30.54	46.98	58.81	74.00	-15.19	peak
2	5149.980	10.14	32.40	30.55	45.07	57.06	74.00	-16.94	peak
3	5250.000	10.31	32.60	30.58	81.19	93.52	68.20	25.32	peak
4	5350.200	10.45	32.80	30.61	45.87	58.51	74.00	-15.49	peak
5	5395.387	10.60	32.80	30.63	48.93	61.70	74.00	-12.30	peak
6	5459.980	10.60	32.90	30.64	46.84	59.70	74.00	-14.30	peak



11ac_VHT(160M)_TX_CH_50_Vertical-Avg

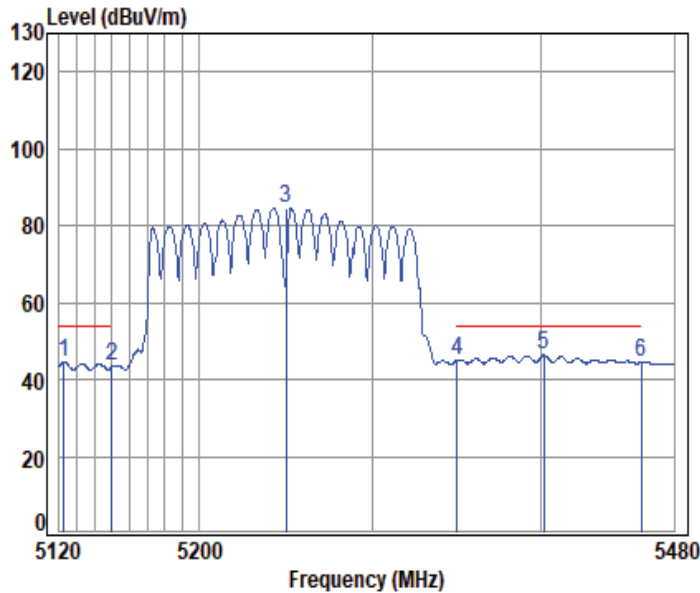

Condition: 3m VERTICAL

Job No : 01607WM

Mode : 5250 Band edge

: 5G Wi-Fi 11ac160

	Cable Freq	Ant Loss	Preamp Factor	Read Level	Limit Level	Over Limit	Remark
	MHz	dB	dB/m	dB	dBuV	dBuV/m	dB
1	5122.784	10.04	32.35	30.54	32.65	44.50	-9.50 Average
2	5150.000	10.14	32.40	30.55	31.29	43.28	-10.72 Average
3	5250.000	10.31	32.60	30.58	72.17	84.50	----- Average
4	5350.000	10.45	32.80	30.61	32.47	45.11	-8.89 Average
5	5401.624	10.62	32.80	30.63	33.49	46.28	-7.72 Average
6	5460.000	10.60	32.90	30.64	31.54	44.40	-9.60 Average



Unless otherwise agreed in writing, this document is issued by the Company subject to its General Conditions of Service printed overleaf, available on request or accessible at <https://www.sgs.com/en/Terms-and-Conditions>. Attention is drawn to the limitation of liability, indemnification and jurisdiction issues defined therein. Any holder of this document is advised that information contained hereon reflects the Company's findings at the time of its intervention only and within the limits of Client's instructions, if any. The Company's sole responsibility is to its Client and this document does not exonerate parties to a transaction from exercising all their rights and obligations under the transaction documents. This document cannot be reproduced except in full, without prior written approval of the Company. Any unauthorized alteration, forgery or falsification of the content or appearance of this document is unlawful and offenders may be prosecuted to the fullest extent of the law. Unless otherwise stated the results shown in this test report refer only to the sample(s) tested and such sample(s) are retained for 30 days only.

Attention: To check the authenticity of testing /inspection report & certificate, please contact us at telephone: (86-755) 8307 1443, or email: CN.Doccheck@sgs.com
 No.1 Workshop, M-10, Middle Section, Science & Technology Park, Nanshan District, Shenzhen, Guangdong, China 518057 t (86-755) 26012053 f (86-755) 26710594 www.sgs.com.cn
 中国·广东·深圳市南山区科技园中区M-10栋1号厂房 邮编: 518057 t (86-755) 26012053 f (86-755) 26710594 sgs.china@sgs.com

11ax_20M_TX_CH_64_Horizontal-Peak

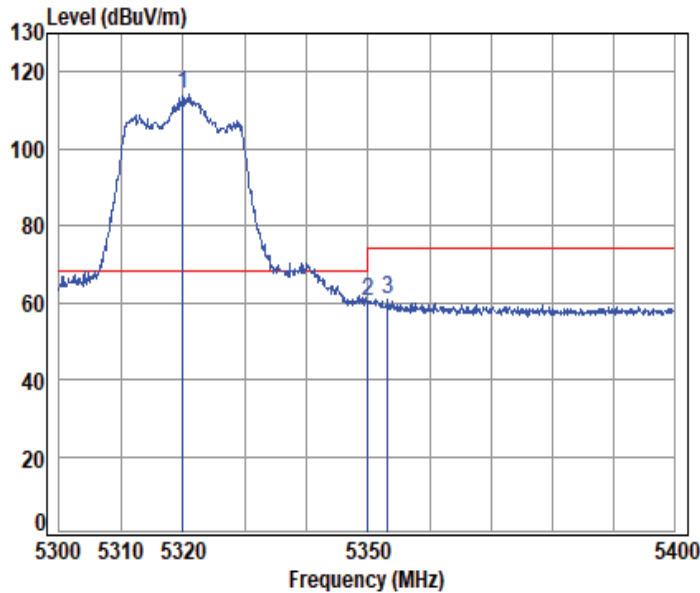

Condition: 3m HORIZONTAL

Job No : 01607WM

Mode : 5320 Band edge

: 5G Wi-Fi 11ax20

	Cable	Ant	Preamp	Read	Limit	Over			
Freq	Loss	Factor	Factor	Level	Level	Line	Limit	Remark	
MHz	dB	dB/m	dB	dBuV	dBuV/m	dBuV/m	dB		
1 pp 5320.000	10.35	32.74	30.60	101.74	114.23	68.20	46.03	peak	
2 5350.020	10.45	32.80	30.61	47.89	60.53	74.00	-13.47	peak	
3 5353.167	10.46	32.80	30.61	48.26	60.91	74.00	-13.09	peak	



Unless otherwise agreed in writing, this document is issued by the Company subject to its General Conditions of Service printed overleaf, available on request or accessible at <https://www.sgs.com/en/Terms-and-Conditions>. Attention is drawn to the limitation of liability, indemnification and jurisdiction issues defined therein. Any holder of this document is advised that information contained hereon reflects the Company's findings at the time of its intervention only and within the limits of Client's instructions, if any. The Company's sole responsibility is to its Client and this document does not exonerate parties to a transaction from exercising all their rights and obligations under the transaction documents. This document cannot be reproduced except in full, without prior written approval of the Company. Any unauthorized alteration, forgery or falsification of the content or appearance of this document is unlawful and offenders may be prosecuted to the fullest extent of the law. Unless otherwise stated the results shown in this test report refer only to the sample(s) tested and such sample(s) are retained for 30 days only.

Attention: To check the authenticity of testing /inspection report & certificate, please contact us at telephone: (86-755) 8307 1443, or email: CN.Doccheck@sgs.com
 No.1 Workshop, M-10, Middle Section, Science & Technology Park, Nanshan District, Shenzhen, Guangdong, China 518057 t (86-755) 26012053 f (86-755) 26710594 www.sgs.com.cn
 中国·广东·深圳市南山区科技园中区M-10栋1号厂房 邮编: 518057 t (86-755) 26012053 f (86-755) 26710594 sgs.china@sgs.com

11ax_20M_TX_CH_64_Horizontal-Avg

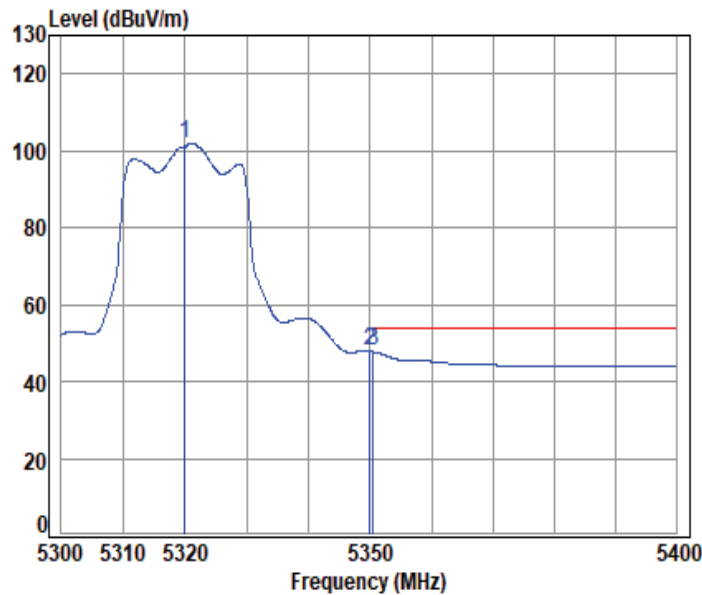

Condition: 3m HORIZONTAL

Job No : 01607WM

Mode : 5320 Band edge

: 5G Wi-Fi 11ax20

	Cable	Ant	Preamp	Read	Limit	Over		
Freq	Loss	Factor	Factor	Level	Level	Line	Limit	Remark
MHz	dB	dB/m	dB	dBuV	dBuV/m	dBuV/m	dB	
1	5320.000	10.35	32.74	30.60	89.53	102.02	-----	----- Average
2	pp 5350.020	10.45	32.80	30.61	35.19	47.83	54.00	-6.17 Average
3	5350.566	10.45	32.80	30.61	35.07	47.71	54.00	-6.29 Average



Unless otherwise agreed in writing, this document is issued by the Company subject to its General Conditions of Service printed overleaf, available on request or accessible at <https://www.sgs.com/en/Terms-and-Conditions>. Attention is drawn to the limitation of liability, indemnification and jurisdiction issues defined therein. Any holder of this document is advised that information contained hereon reflects the Company's findings at the time of its intervention only and within the limits of Client's instructions, if any. The Company's sole responsibility is to its Client and this document does not exonerate parties to a transaction from exercising all their rights and obligations under the transaction documents. This document cannot be reproduced except in full, without prior written approval of the Company. Any unauthorized alteration, forgery or falsification of the content or appearance of this document is unlawful and offenders may be prosecuted to the fullest extent of the law. Unless otherwise stated the results shown in this test report refer only to the sample(s) tested and such sample(s) are retained for 30 days only.

Attention: To check the authenticity of testing /inspection report & certificate, please contact us at telephone: (86-755) 8307 1443, or email: CN.Doccheck@sgs.com
 No.1 Workshop, M-10, Middle Section, Science & Technology Park, Nanshan District, Shenzhen, Guangdong, China 518057 t (86-755) 26012053 f (86-755) 26710594 www.sgs.com.cn
 中国·广东·深圳市南山区科技园中区M-10栋1号厂房 邮编: 518057 t (86-755) 26012053 f (86-755) 26710594 sgs.china@sgs.com

11ax_20M_TX_CH_64_Vertical-Peak

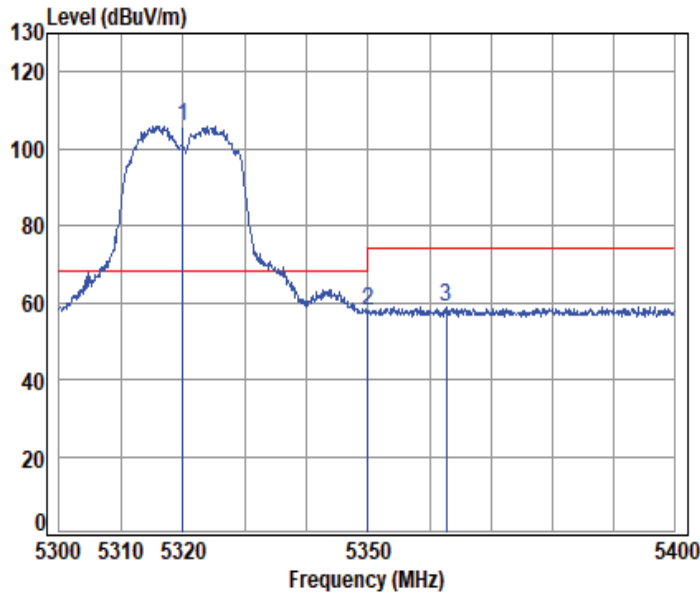

Condition: 3m VERTICAL

Job No : 01607WM

Mode : 5320 Band edge

: 5G Wi-Fi 11ax20

	Cable	Ant	Preamp	Read	Limit	Over			
Freq	Loss	Factor	Factor	Level	Level	Line	Limit	Remark	
MHz	dB	dB/m	dB	dBuV	dBuV/m	dBuV/m	dB		
1 pp 5320.000	10.35	32.74	30.60	93.52	106.01	68.20	37.81	peak	
2 5350.020	10.45	32.80	30.61	45.28	57.92	74.00	-16.08	peak	
3 5362.682	10.49	32.80	30.62	46.23	58.90	74.00	-15.10	peak	



Unless otherwise agreed in writing, this document is issued by the Company subject to its General Conditions of Service printed overleaf, available on request or accessible at <https://www.sgs.com/en/Terms-and-Conditions>. Attention is drawn to the limitation of liability, indemnification and jurisdiction issues defined therein. Any holder of this document is advised that information contained hereon reflects the Company's findings at the time of its intervention only and within the limits of Client's instructions, if any. The Company's sole responsibility is to its Client and this document does not exonerate parties to a transaction from exercising all their rights and obligations under the transaction documents. This document cannot be reproduced except in full, without prior written approval of the Company. Any unauthorized alteration, forgery or falsification of the content or appearance of this document is unlawful and offenders may be prosecuted to the fullest extent of the law. Unless otherwise stated the results shown in this test report refer only to the sample(s) tested and such sample(s) are retained for 30 days only.

Attention: To check the authenticity of testing /inspection report & certificate, please contact us at telephone: (86-755) 8307 1443, or email: CN.Doccheck@sgs.com
 No.1 Workshop, M-10, Middle Section, Science & Technology Park, Nanshan District, Shenzhen, Guangdong, China 518057 t (86-755) 26012053 f (86-755) 26710594 www.sgs.com.cn
 中国·广东·深圳市南山区科技园中区M-10栋1号厂房 邮编: 518057 t (86-755) 26012053 f (86-755) 26710594 sgs.china@sgs.com

11ax_20M_TX_CH_64_Vertical-Avg

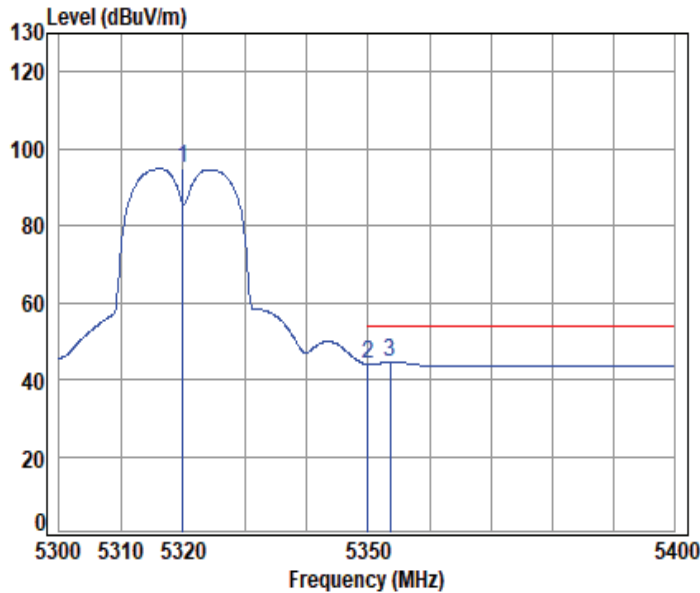

Condition: 3m VERTICAL

Job No : 01607WM

Mode : 5320 Band edge

: 5G Wi-Fi 11ax20

	Cable	Ant	Preamp	Read	Limit	Over		
Freq	Loss	Factor	Factor	Level	Level	Line	Limit	Remark
MHz	dB	dB/m	dB	dBuV	dBuV/m	dBuV/m	dB	
1	5320.000	10.35	32.74	30.60	82.35	94.84	-----	----- Average
2	5350.020	10.45	32.80	30.61	31.30	43.94	54.00	-10.06 Average
3	pp 5353.568	10.46	32.80	30.61	31.80	44.45	54.00	-9.55 Average



11ax_40M_TX_CH_62_Horizontal-Peak

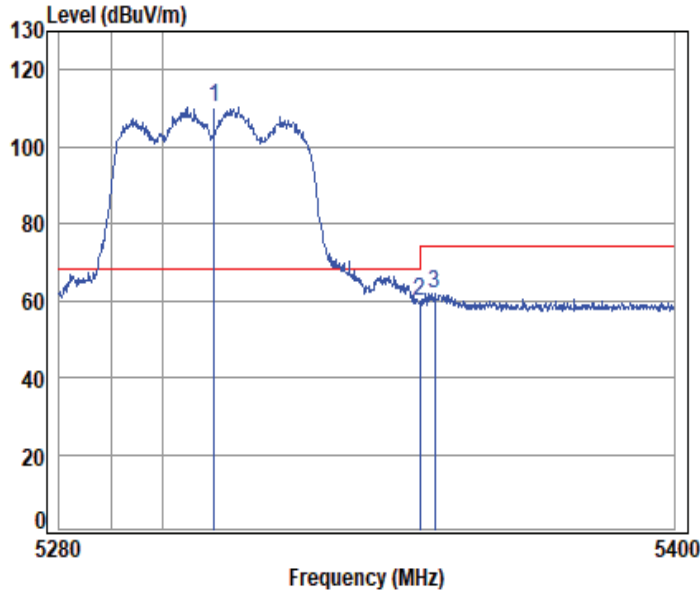

Condition: 3m HORIZONTAL

Job No : 01607WM

Mode : 5310 Band edge

: 5G Wi-Fi 11ax40

	Cable	Ant	Preamp	Read	Limit	Over			
Freq	Loss	Factor	Factor	Level	Level	Line	Limit	Remark	
MHz	dB	dB/m	dB	dBuV	dBuV/m	dBuV/m	dB		
1 pp 5310.000	10.31	32.72	30.60	97.87	110.30	68.20	42.10	peak	
2 5350.020	10.45	32.80	30.61	47.03	59.67	74.00	-14.33	peak	
3 5352.999	10.46	32.80	30.61	49.31	61.96	74.00	-12.04	peak	



Unless otherwise agreed in writing, this document is issued by the Company subject to its General Conditions of Service printed overleaf, available on request or accessible at <https://www.sgs.com/en/Terms-and-Conditions>. Attention is drawn to the limitation of liability, indemnification and jurisdiction issues defined therein. Any holder of this document is advised that information contained hereon reflects the Company's findings at the time of its intervention only and within the limits of Client's instructions, if any. The Company's sole responsibility is to its Client and this document does not exonerate parties to a transaction from exercising all their rights and obligations under the transaction documents. This document cannot be reproduced except in full, without prior written approval of the Company. Any unauthorized alteration, forgery or falsification of the content or appearance of this document is unlawful and offenders may be prosecuted to the fullest extent of the law. Unless otherwise stated the results shown in this test report refer only to the sample(s) tested and such sample(s) are retained for 30 days only.

Attention: To check the authenticity of testing /inspection report & certificate, please contact us at telephone: (86-755) 8307 1443, or email: CN.Doccheck@sgs.com
 No.1 Workshop, M-10, Middle Section, Science & Technology Park, Nanshan District, Shenzhen, Guangdong, China 518057 t (86-755) 26012053 f (86-755) 26710594 www.sgs.com.cn
 中国·广东·深圳市南山区科技园中区M-10栋1号厂房 邮编: 518057 t (86-755) 26012053 f (86-755) 26710594 sgs.china@sgs.com

11ax_40M_TX_CH_62_Horizontal-Avg

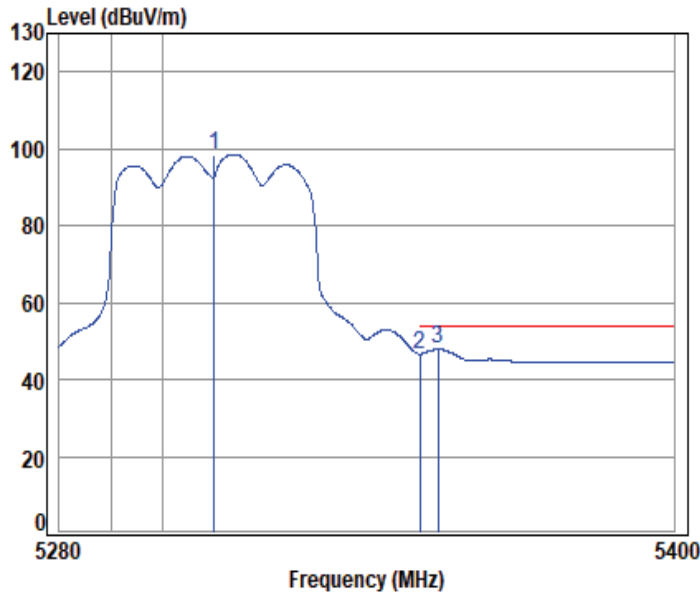

Condition: 3m HORIZONTAL

Job No : 01607WM

Mode : 5310 Band edge

: 5G Wi-Fi 11ax40

	Cable	Ant	Preamp	Read	Limit	Over		
Freq	Loss	Factor	Factor	Level	Level	Line	Limit	Remark
MHz	dB	dB/m	dB	dBuV	dBuV/m	dBuV/m	dB	
1	5310.000	10.31	32.72	30.60	86.18	98.61	-----	----- Average
2	5350.020	10.45	32.80	30.61	34.05	46.69	54.00	-7.31 Average
3	pp 5353.601	10.46	32.80	30.61	35.20	47.85	54.00	-6.15 Average



Unless otherwise agreed in writing, this document is issued by the Company subject to its General Conditions of Service printed overleaf, available on request or accessible at <https://www.sgs.com/en/Terms-and-Conditions>. Attention is drawn to the limitation of liability, indemnification and jurisdiction issues defined therein. Any holder of this document is advised that information contained hereon reflects the Company's findings at the time of its intervention only and within the limits of Client's instructions, if any. The Company's sole responsibility is to its Client and this document does not exonerate parties to a transaction from exercising all their rights and obligations under the transaction documents. This document cannot be reproduced except in full, without prior written approval of the Company. Any unauthorized alteration, forgery or falsification of the content or appearance of this document is unlawful and offenders may be prosecuted to the fullest extent of the law. Unless otherwise stated the results shown in this test report refer only to the sample(s) tested and such sample(s) are retained for 30 days only.

Attention: To check the authenticity of testing /inspection report & certificate, please contact us at telephone: (86-755) 8307 1443, or email: CN.Doccheck@sgs.com
 No.1 Workshop, M-10, Middle Section, Science & Technology Park, Nanshan District, Shenzhen, Guangdong, China 518057 t (86-755) 26012053 f (86-755) 26710594 www.sgs.com.cn
 中国·广东·深圳市南山区科技园中区M-10栋1号厂房 邮编: 518057 t (86-755) 26012053 f (86-755) 26710594 sgs.china@sgs.com

11ax_40M_TX_CH_62_Vertical-Peak

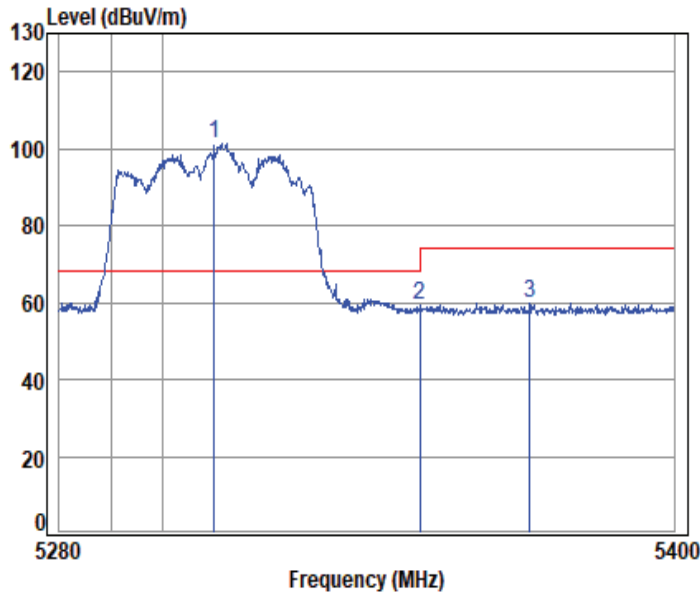

Condition: 3m VERTICAL

Job No : 01607WM

Mode : 5310 Band edge

: 5G Wi-Fi 11ax40

	Cable	Ant	Preamp	Read	Limit	Over			
Freq	Loss	Factor	Factor	Level	Level	Line	Limit	Remark	
MHz	dB	dB/m	dB	dBuV	dBuV/m	dBuV/m	dB		
1 pp 5310.000	10.31	32.72	30.60	89.06	101.49	68.20	33.29	peak	
2 5350.020	10.45	32.80	30.61	46.77	59.41	74.00	-14.59	peak	
3 5371.557	10.52	32.80	30.62	47.25	59.95	74.00	-14.05	peak	



Unless otherwise agreed in writing, this document is issued by the Company subject to its General Conditions of Service printed overleaf, available on request or accessible at <https://www.sgs.com/en/Terms-and-Conditions>. Attention is drawn to the limitation of liability, indemnification and jurisdiction issues defined therein. Any holder of this document is advised that information contained hereon reflects the Company's findings at the time of its intervention only and within the limits of Client's instructions, if any. The Company's sole responsibility is to its Client and this document does not exonerate parties to a transaction from exercising all their rights and obligations under the transaction documents. This document cannot be reproduced except in full, without prior written approval of the Company. Any unauthorized alteration, forgery or falsification of the content or appearance of this document is unlawful and offenders may be prosecuted to the fullest extent of the law. Unless otherwise stated the results shown in this test report refer only to the sample(s) tested and such sample(s) are retained for 30 days only.

Attention: To check the authenticity of testing /inspection report & certificate, please contact us at telephone: (86-755) 8307 1443, or email: CN.Doccheck@sgs.com
 No.1 Workshop, M-10, Middle Section, Science & Technology Park, Nanshan District, Shenzhen, Guangdong, China 518057 t (86-755) 26012053 f (86-755) 26710594 www.sgs.com.cn
 中国·广东·深圳市南山区科技园中区M-10栋1号厂房 邮编: 518057 t (86-755) 26012053 f (86-755) 26710594 sgs.china@sgs.com

11ax_40M_TX_CH_62_Vertical-Avg

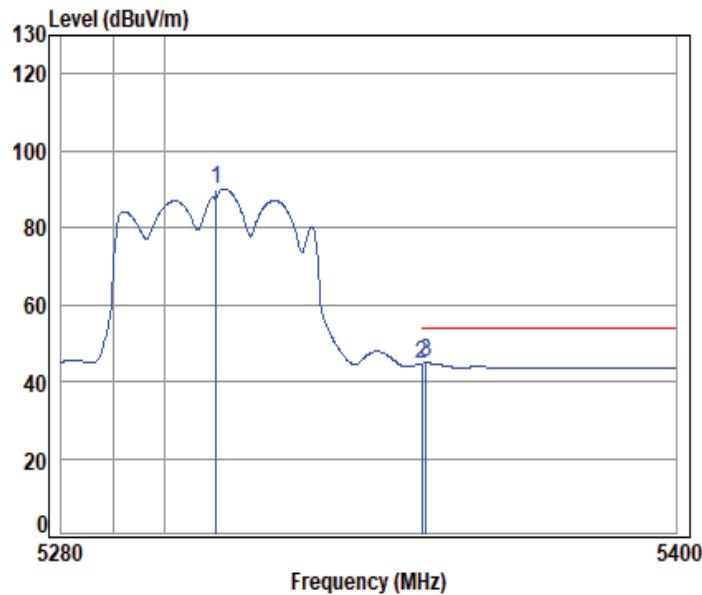

Condition: 3m VERTICAL

Job No : 01607WM

Mode : 5310 Band edge

: 5G Wi-Fi 11ax40

	Cable	Ant	Preamp	Read	Limit	Over		
Freq	Loss	Factor	Factor	Level	Level	Line	Limit	Remark
MHz	dB	dB/m	dB	dBuV	dBuV/m	dBuV/m	dB	
1	5310.000	10.31	32.72	30.60	77.67	90.10	-----	----- Average
2	5350.020	10.45	32.80	30.61	32.09	44.73	54.00	-9.27 Average
3	pp 5350.955	10.45	32.80	30.61	32.17	44.81	54.00	-9.19 Average



Unless otherwise agreed in writing, this document is issued by the Company subject to its General Conditions of Service printed overleaf, available on request or accessible at <https://www.sgs.com/en/Terms-and-Conditions>. Attention is drawn to the limitation of liability, indemnification and jurisdiction issues defined therein. Any holder of this document is advised that information contained hereon reflects the Company's findings at the time of its intervention only and within the limits of Client's instructions, if any. The Company's sole responsibility is to its Client and this document does not exonerate parties to a transaction from exercising all their rights and obligations under the transaction documents. This document cannot be reproduced except in full, without prior written approval of the Company. Any unauthorized alteration, forgery or falsification of the content or appearance of this document is unlawful and offenders may be prosecuted to the fullest extent of the law. Unless otherwise stated the results shown in this test report refer only to the sample(s) tested and such sample(s) are retained for 30 days only.

Attention: To check the authenticity of testing /inspection report & certificate, please contact us at telephone: (86-755) 8307 1443, or email: CN.Doccheck@sgs.com
 No.1 Workshop, M-10, Middle Section, Science & Technology Park, Nanshan District, Shenzhen, Guangdong, China 518057 t (86-755) 26012053 f (86-755) 26710594 www.sgs.com.cn
 中国·广东·深圳市南山区科技园中区M-10栋1号厂房 邮编: 518057 t (86-755) 26012053 f (86-755) 26710594 sgs.china@sgs.com

11ax_80M_TX_CH_58_Horizontal-Peak

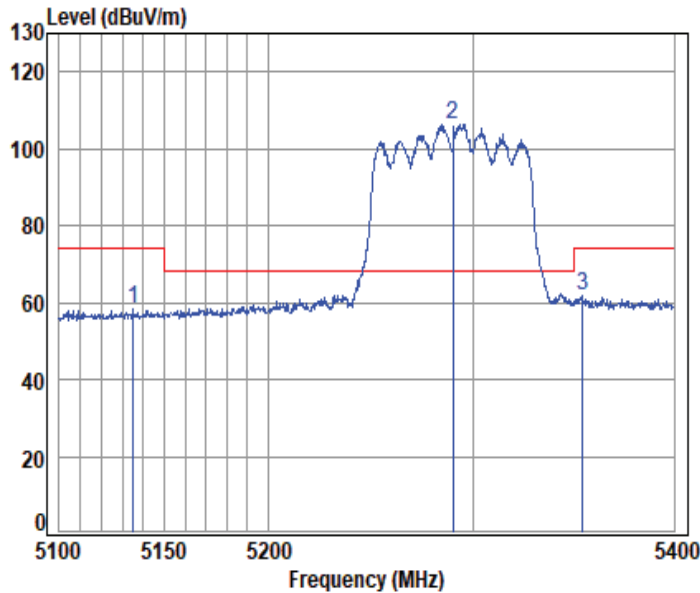

Condition: 3m HORIZONTAL

Job No : 01607WM

Mode : 5290 Band edge

: 5G Wi-Fi 11ax80

	Cable	Ant	Preamp	Read	Limit	Over			
Freq	Loss	Factor	Factor	Level	Level	Line	Limit	Remark	
MHz	dB	dB/m	dB	dBuV	dBuV/m	dBuV/m	dB		
1	5135.395	10.08	32.37	30.54	46.23	58.14	74.00	-15.86 peak	
2	pp 5290.000	10.28	32.68	30.59	93.94	106.31	68.20	38.11 peak	
3	5354.512	10.47	32.80	30.61	49.31	61.97	74.00	-12.03 peak	



11ax_80M_TX_CH_58_Horizontal-Avg

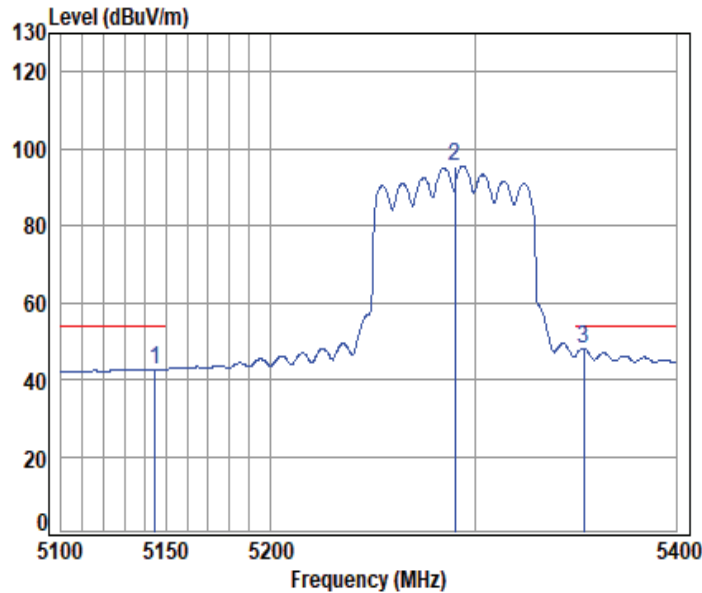

Condition: 3m HORIZONTAL

Job No : 01607WM

Mode : 5290 Band edge

: 5G Wi-Fi 11ax80

	Cable	Ant	Preamp	Read	Limit	Over			
Freq	Loss	Factor	Factor	Level	Level	Line	Limit	Remark	
MHz	dB	dB/m	dB	dBuV	dBuV/m	dBuV/m	dB		
1	5144.796	10.12	32.39	30.55	30.77	42.73	54.00	-11.27	Average
2	5290.000	10.28	32.68	30.59	83.06	95.43	-----	-----	Average
3	pp 5353.899	10.46	32.80	30.61	35.42	48.07	54.00	-5.93	Average



Unless otherwise agreed in writing, this document is issued by the Company subject to its General Conditions of Service printed overleaf, available on request or accessible at <https://www.sgs.com/en/Terms-and-Conditions>. Attention is drawn to the limitation of liability, indemnification and jurisdiction issues defined therein. Any holder of this document is advised that information contained hereon reflects the Company's findings at the time of its intervention only and within the limits of Client's instructions, if any. The Company's sole responsibility is to its Client and this document does not exonerate parties to a transaction from exercising all their rights and obligations under the transaction documents. This document cannot be reproduced except in full, without prior written approval of the Company. Any unauthorized alteration, forgery or falsification of the content or appearance of this document is unlawful and offenders may be prosecuted to the fullest extent of the law. Unless otherwise stated the results shown in this test report refer only to the sample(s) tested and such sample(s) are retained for 30 days only.

Attention: To check the authenticity of testing /inspection report & certificate, please contact us at telephone: (86-755) 8307 1443, or email: CN.Doccheck@sgs.com
 No.1 Workshop, M-10, Middle Section, Science & Technology Park, Nanshan District, Shenzhen, Guangdong, China 518057 t (86-755) 26012053 f (86-755) 26710594 www.sgs.com.cn
 中国·广东·深圳市南山区科技园中区M-10栋1号厂房 邮编: 518057 t (86-755) 26012053 f (86-755) 26710594 sgs.china@sgs.com

11ax_80M_TX_CH_58_Verical-Peak

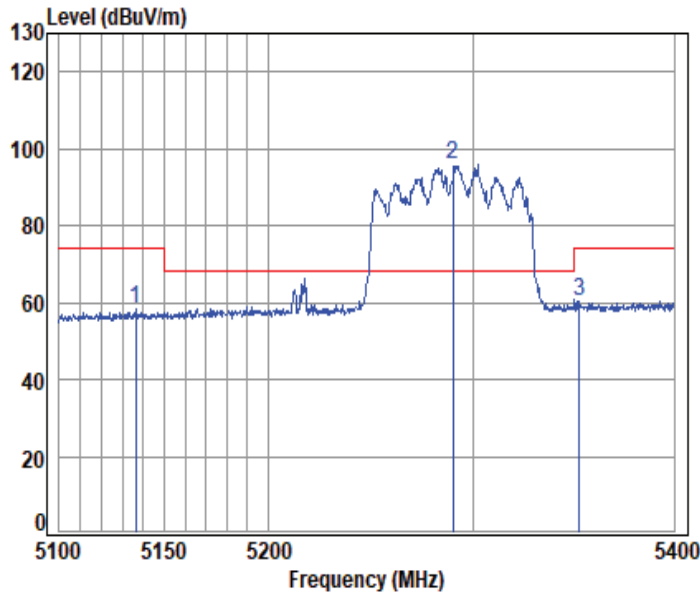

Condition: 3m VERTICAL

Job No : 01607WM

Mode : 5290 Band edge

: 5G Wi-Fi 11ax80

	Cable	Ant	Preamp	Read	Limit	Over			
Freq	Loss	Factor	Factor	Level	Level	Line	Limit	Remark	
MHz	dB	dB/m	dB	dBuV	dBuV/m	dBuV/m	dB		
1	5136.569	10.09	32.37	30.54	46.36	58.28	74.00	-15.72 peak	
2	pp 5290.000	10.28	32.68	30.59	83.62	95.99	68.20	27.79 peak	
3	5352.676	10.46	32.80	30.61	47.75	60.40	74.00	-13.60 peak	



11ax_80M_TX_CH_58_Verical-Avg

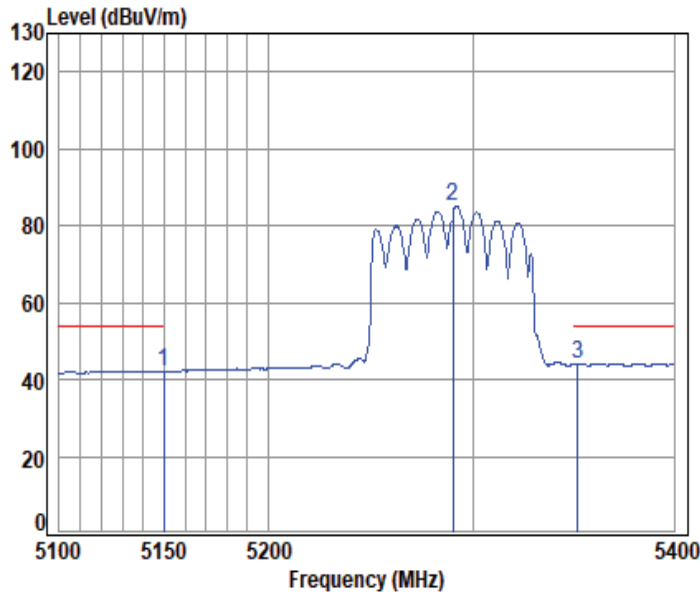

Condition: 3m VERTICAL

Job No : 01607WM

Mode : 5290 Band edge

: 5G Wi-Fi 11ax80

	Cable	Ant	Preamp	Read	Limit	Over			
Freq	Loss	Factor	Factor	Level	Level	Line	Limit	Remark	
MHz	dB	dB/m	dB	dBuV	dBuV/m	dBuV/m	dB		
1	5149.798	10.14	32.40	30.55	30.22	42.21	54.00	-11.79	Average
2	5290.000	10.28	32.68	30.59	72.49	84.86	-----	-----	Average
3	pp 5351.758	10.46	32.80	30.61	31.59	44.24	54.00	-9.76	Average



Unless otherwise agreed in writing, this document is issued by the Company subject to its General Conditions of Service printed overleaf, available on request or accessible at <https://www.sgs.com/en/Terms-and-Conditions>. Attention is drawn to the limitation of liability, indemnification and jurisdiction issues defined therein. Any holder of this document is advised that information contained hereon reflects the Company's findings at the time of its intervention only and within the limits of Client's instructions, if any. The Company's sole responsibility is to its Client and this document does not exonerate parties to a transaction from exercising all their rights and obligations under the transaction documents. This document cannot be reproduced except in full, without prior written approval of the Company. Any unauthorized alteration, forgery or falsification of the content or appearance of this document is unlawful and offenders may be prosecuted to the fullest extent of the law. Unless otherwise stated the results shown in this test report refer only to the sample(s) tested and such sample(s) are retained for 30 days only.

Attention: To check the authenticity of testing /inspection report & certificate, please contact us at telephone: (86-755) 8307 1443, or email: CN.Doccheck@sgs.com
 No.1 Workshop, M-10, Middle Section, Science & Technology Park, Nanshan District, Shenzhen, Guangdong, China 518057 t (86-755) 26012053 f (86-755) 26710594 www.sgs.com.cn
 中国·广东·深圳市南山区科技园中区M-10栋1号厂房 邮编: 518057 t (86-755) 26012053 f (86-755) 26710594 sgs.china@sgs.com

11ax_160M_TX_CH_50_Horizontal-Peak

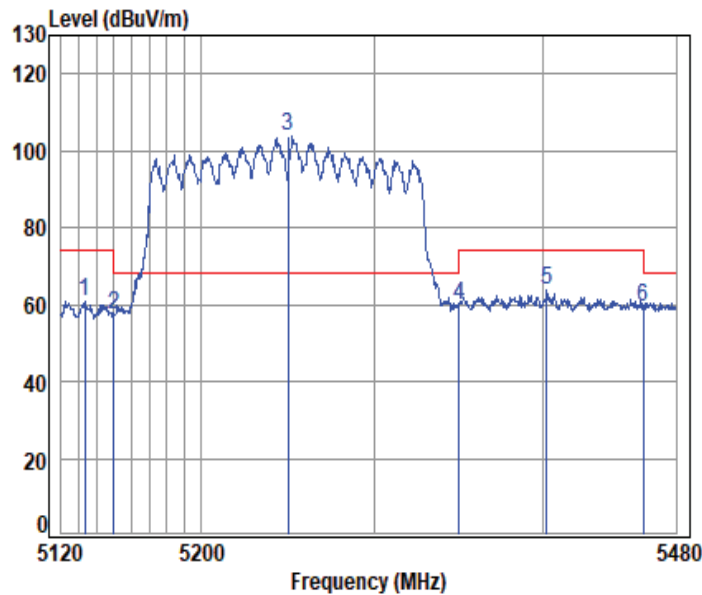

Condition: 3m HORIZONTAL

Job No : 01607WM

Mode : 5250 Band edge

: 5G Wi-Fi 11ax160

	Cable	Ant	Preamp	Read	Limit	Over			
	Freq	Loss	Factor	Factor	Level	Level	Line	Limit	Remark
	MHz	dB	dB/m	dB	dBuV	dBuV/m	dBuV/m	dB	
1	5133.586	10.08	32.37	30.54	49.07	60.98	74.00	-13.02	peak
2	5149.980	10.14	32.40	30.55	45.34	57.33	74.00	-16.67	peak
3	5250.000	10.31	32.60	30.58	91.27	103.60	68.20	35.40	peak
4	5350.200	10.45	32.80	30.61	47.05	59.69	74.00	-14.31	peak
5	5402.357	10.62	32.80	30.63	50.91	63.70	74.00	-10.30	peak
6	5459.980	10.60	32.90	30.64	46.51	59.37	74.00	-14.63	peak



Unless otherwise agreed in writing, this document is issued by the Company subject to its General Conditions of Service printed overleaf, available on request or accessible at <https://www.sgs.com/en/Terms-and-Conditions>. Attention is drawn to the limitation of liability, indemnification and jurisdiction issues defined therein. Any holder of this document is advised that information contained hereon reflects the Company's findings at the time of its intervention only and within the limits of Client's instructions, if any. The Company's sole responsibility is to its Client and this document does not exonerate parties to a transaction from exercising all their rights and obligations under the transaction documents. This document cannot be reproduced except in full, without prior written approval of the Company. Any unauthorized alteration, forgery or falsification of the content or appearance of this document is unlawful and offenders may be prosecuted to the fullest extent of the law. Unless otherwise stated the results shown in this test report refer only to the sample(s) tested and such sample(s) are retained for 30 days only.

Attention: To check the authenticity of testing /inspection report & certificate, please contact us at telephone: (86-755) 8307 1443, or email: CN.Doccheck@sgs.com
 No.1 Workshop, M-10, Middle Section, Science & Technology Park, Nanshan District, Shenzhen, Guangdong, China 518057 t (86-755) 26012053 f (86-755) 26710594 www.sgsgroup.com.cn
 中国·广东·深圳市南山区科技园中区M-10栋1号厂房 邮编: 518057 t (86-755) 26012053 f (86-755) 26710594 sgs.china@sgs.com

11ax_160M_TX_CH_50_Horizontal-Avg

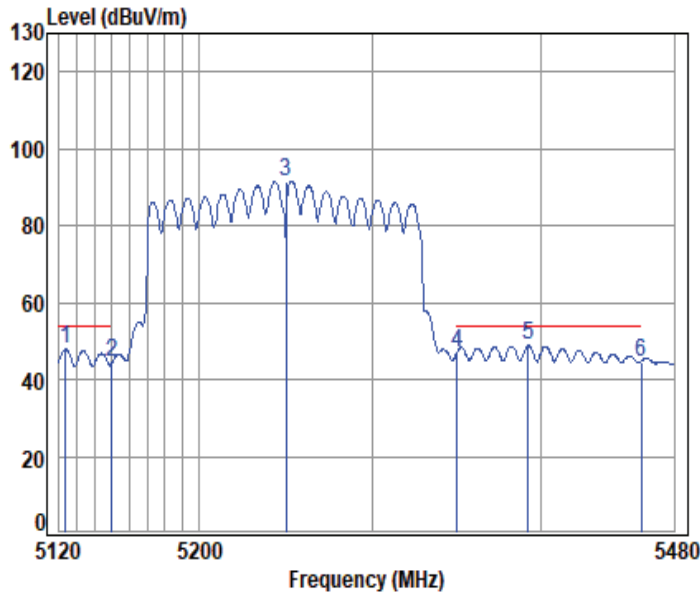

Condition: 3m HORIZONTAL

Job No : 01607WM

Mode : 5250 Band edge

: 5G Wi-Fi 11ax160

	Cable	Ant	Preamp	Read	Limit	Over			
	Freq	Loss	Factor	Factor	Level	Level	Line	Limit	Remark
	MHz	dB	dB/m	dB	dBuV	dBuV/m	dBuV/m	dB	
1	5123.480	10.04	32.35	30.54	35.87	47.72	54.00	-6.28	Average
2	5150.000	10.14	32.40	30.55	32.32	44.31	54.00	-9.69	Average
3	5250.000	10.31	32.60	30.58	79.18	91.51	-----	-----	Average
4	5350.000	10.45	32.80	30.61	34.54	47.18	54.00	-6.82	Average
5	pp 5392.455	10.59	32.80	30.62	35.98	48.75	54.00	-5.25	Average
6	5460.000	10.60	32.90	30.64	31.86	44.72	54.00	-9.28	Average



Unless otherwise agreed in writing, this document is issued by the Company subject to its General Conditions of Service printed overleaf, available on request or accessible at <https://www.sgs.com/en/Terms-and-Conditions>. Attention is drawn to the limitation of liability, indemnification and jurisdiction issues defined therein. Any holder of this document is advised that information contained hereon reflects the Company's findings at the time of its intervention only and within the limits of Client's instructions, if any. The Company's sole responsibility is to its Client and this document does not exonerate parties to a transaction from exercising all their rights and obligations under the transaction documents. This document cannot be reproduced except in full, without prior written approval of the Company. Any unauthorized alteration, forgery or falsification of the content or appearance of this document is unlawful and offenders may be prosecuted to the fullest extent of the law. Unless otherwise stated the results shown in this test report refer only to the sample(s) tested and such sample(s) are retained for 30 days only.

Attention: To check the authenticity of testing /inspection report & certificate, please contact us at telephone: (86-755) 8307 1443, or email: CN.Doccheck@sgs.com
 No.1 Workshop, M-10, Middle Section, Science & Technology Park, Nanshan District, Shenzhen, Guangdong, China 518057 t (86-755) 26012053 f (86-755) 26710594 www.sgs.com.cn
 中国·广东·深圳市南山区科技园中区M-10栋1号厂房 邮编: 518057 t (86-755) 26012053 f (86-755) 26710594 sgs.china@sgs.com

11ax_160M_TX_CH_50_Vertical-Peak

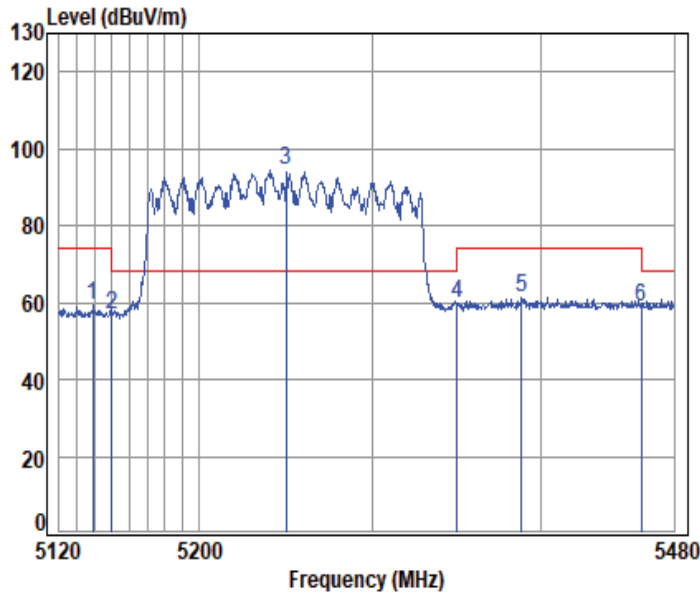

Condition: 3m VERTICAL

Job No : 01607WM

Mode : 5250 Band edge

: 5G Wi-Fi 11ax160

	Cable	Ant	Preamp	Read	Limit	Over		
Freq	Loss	Factor	Factor	Level	Level	Line	Limit	Remark
MHz	dB	dB/m	dB	dBuV	dBuV/m	dBuV/m	dB	
1	5139.171	10.10	32.38	30.55	47.17	59.10	74.00	-14.90 peak
2	5149.980	10.14	32.40	30.55	44.69	56.68	74.00	-17.32 peak
3	pp 5250.000	10.31	32.60	30.58	81.87	94.20	68.20	26.00 peak
4	5350.200	10.45	32.80	30.61	47.19	59.83	74.00	-14.17 peak
5	5388.426	10.58	32.80	30.62	48.69	61.45	74.00	-12.55 peak
6	5459.980	10.60	32.90	30.64	46.10	58.96	74.00	-15.04 peak



Unless otherwise agreed in writing, this document is issued by the Company subject to its General Conditions of Service printed overleaf, available on request or accessible at <https://www.sgs.com/en/Terms-and-Conditions>. Attention is drawn to the limitation of liability, indemnification and jurisdiction issues defined therein. Any holder of this document is advised that information contained hereon reflects the Company's findings at the time of its intervention only and within the limits of Client's instructions, if any. The Company's sole responsibility is to its Client and this document does not exonerate parties to a transaction from exercising all their rights and obligations under the transaction documents. This document cannot be reproduced except in full, without prior written approval of the Company. Any unauthorized alteration, forgery or falsification of the content or appearance of this document is unlawful and offenders may be prosecuted to the fullest extent of the law. Unless otherwise stated the results shown in this test report refer only to the sample(s) tested and such sample(s) are retained for 30 days only.

Attention: To check the authenticity of testing /inspection report & certificate, please contact us at telephone: (86-755) 8307 1443, or email: CN.Doccheck@sgs.com
 No.1 Workshop, M-10, Middle Section, Science & Technology Park, Nanshan District, Shenzhen, Guangdong, China 518057 t (86-755) 26012053 f (86-755) 26710594 www.sgs.com.cn
 中国·广东·深圳市南山区科技园中区M-10栋1号厂房 邮编: 518057 t (86-755) 26012053 f (86-755) 26710594 sgs.china@sgs.com

11ax_160M_TX_CH_50_Vertical-Avg

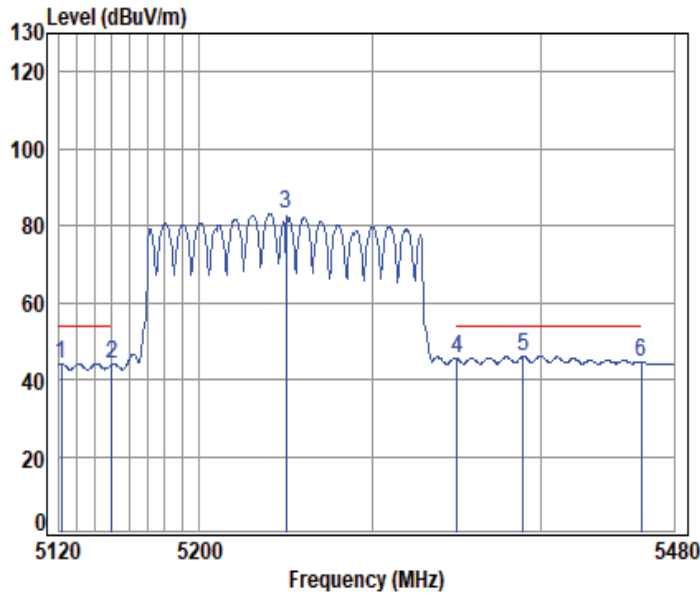

Condition: 3m VERTICAL

Job No : 01607WM

Mode : 5250 Band edge

: 5G Wi-Fi 11ax160

	Cable Freq	Ant Loss	Preamp Factor	Read Level	Limit Level	Over Limit	Remark
	MHz	dB	dB/m	dB	dBuV	dBuV/m	dB
1	5121.392	10.03	32.34	30.54	32.24	44.07	-9.93 Average
2	5150.000	10.14	32.40	30.55	31.86	43.85	-10.15 Average
3	5250.000	10.31	32.60	30.58	70.83	83.16	----- Average
4	5350.000	10.45	32.80	30.61	32.74	45.38	-8.62 Average
5	pp 5389.524	10.58	32.80	30.62	33.29	46.05	-7.95 Average
6	5460.000	10.60	32.90	30.64	31.71	44.57	-9.43 Average



Unless otherwise agreed in writing, this document is issued by the Company subject to its General Conditions of Service printed overleaf, available on request or accessible at <https://www.sgs.com/en/Terms-and-Conditions>. Attention is drawn to the limitation of liability, indemnification and jurisdiction issues defined therein. Any holder of this document is advised that information contained hereon reflects the Company's findings at the time of its intervention only and within the limits of Client's instructions, if any. The Company's sole responsibility is to its Client and this document does not exonerate parties to a transaction from exercising all their rights and obligations under the transaction documents. This document cannot be reproduced except in full, without prior written approval of the Company. Any unauthorized alteration, forgery or falsification of the content or appearance of this document is unlawful and offenders may be prosecuted to the fullest extent of the law. Unless otherwise stated the results shown in this test report refer only to the sample(s) tested and such sample(s) are retained for 30 days only.

Attention: To check the authenticity of testing /inspection report & certificate, please contact us at telephone: (86-755) 8307 1443, or email: CN.Doccheck@sgs.com
 No.1 Workshop, M-10, Middle Section, Science & Technology Park, Nanshan District, Shenzhen, Guangdong, China 518057 t (86-755) 26012053 f (86-755) 26710594 www.sgs.com.cn
 中国·广东·深圳市南山区科技园中区M-10栋1号厂房 邮编: 518057 t (86-755) 26012053 f (86-755) 26710594 sgs.china@sgs.com

11a_TX_CH_100_Horizontal-Peak

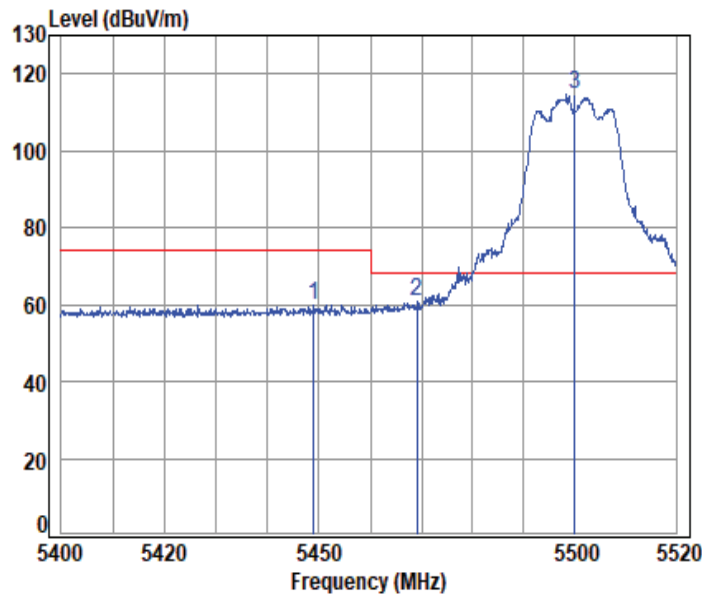

Condition: 3m HORIZONTAL

Job No : 01607WM

Mode : 5500 Band edge

: 5G Wi-Fi 11a

	Cable	Ant	Preamp	Read	Limit	Over		
Freq	Loss	Factor	Factor	Level	Level	Line	Limit	Remark
MHz	dB	dB/m	dB	dBuV	dBuV/m	dBuV/m	dB	
1	5448.881	10.60	32.90	30.64	47.16	60.02	74.00	-13.98 peak
2	5469.158	10.59	32.90	30.65	47.84	60.68	68.20	-7.52 peak
3	pp 5500.000	10.58	32.90	30.66	102.02	114.84	68.20	46.64 peak



Unless otherwise agreed in writing, this document is issued by the Company subject to its General Conditions of Service printed overleaf, available on request or accessible at <https://www.sgs.com/en/Terms-and-Conditions>. Attention is drawn to the limitation of liability, indemnification and jurisdiction issues defined therein. Any holder of this document is advised that information contained hereon reflects the Company's findings at the time of its intervention only and within the limits of Client's instructions, if any. The Company's sole responsibility is to its Client and this document does not exonerate parties to a transaction from exercising all their rights and obligations under the transaction documents. This document cannot be reproduced except in full, without prior written approval of the Company. Any unauthorized alteration, forgery or falsification of the content or appearance of this document is unlawful and offenders may be prosecuted to the fullest extent of the law. Unless otherwise stated the results shown in this test report refer only to the sample(s) tested and such sample(s) are retained for 30 days only.

Attention: To check the authenticity of testing /inspection report & certificate, please contact us at telephone: (86-755) 8307 1443, or email: CN.Doccheck@sgs.com
 No.1 Workshop, M-10, Middle Section, Science & Technology Park, Nanshan District, Shenzhen, Guangdong, China 518057 t (86-755) 26012053 f (86-755) 26710594 www.sgsgroup.com.cn
 中国·广东·深圳市南山区科技园中区M-10栋1号厂房 邮编: 518057 t (86-755) 26012053 f (86-755) 26710594 sgs.china@sgs.com

11a_TX_CH_100_Horizontal-Avg

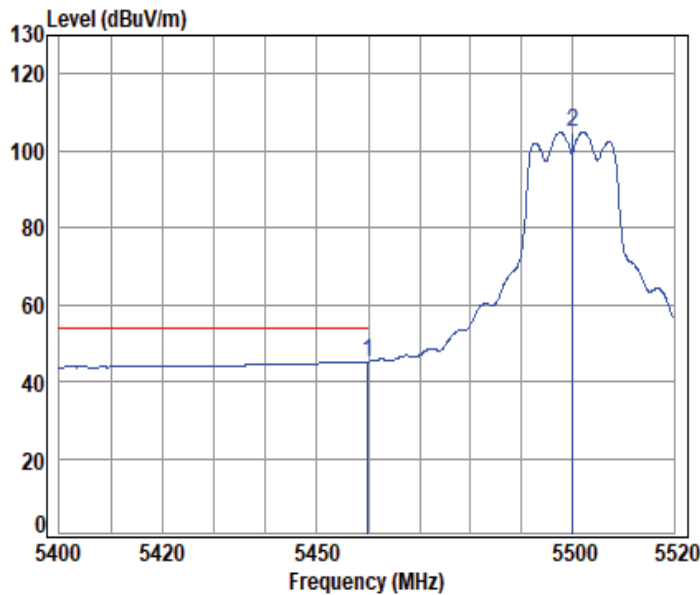

Condition: 3m HORIZONTAL

Job No : 01607WM

Mode : 5500 Band edge

: 5G Wi-Fi 11a

	Cable	Ant	Preamp	Read	Limit	Over			
Freq	Loss	Factor	Factor	Level	Level	Line	Limit	Remark	
MHz	dB	dB/m	dB	dBuV	dBuV/m	dBuV/m	dB		
1 pp 5459.910	10.60	32.90	30.64	32.27	45.13	54.00	-8.87	Average	
2 5500.000	10.58	32.90	30.66	92.03	104.85	-----	-----	Average	



Unless otherwise agreed in writing, this document is issued by the Company subject to its General Conditions of Service printed overleaf, available on request or accessible at <https://www.sgs.com/en/Terms-and-Conditions>. Attention is drawn to the limitation of liability, indemnification and jurisdiction issues defined therein. Any holder of this document is advised that information contained hereon reflects the Company's findings at the time of its intervention only and within the limits of Client's instructions, if any. The Company's sole responsibility is to its Client and this document does not exonerate parties to a transaction from exercising all their rights and obligations under the transaction documents. This document cannot be reproduced except in full, without prior written approval of the Company. Any unauthorized alteration, forgery or falsification of the content or appearance of this document is unlawful and offenders may be prosecuted to the fullest extent of the law. Unless otherwise stated the results shown in this test report refer only to the sample(s) tested and such sample(s) are retained for 30 days only.

Attention: To check the authenticity of testing /inspection report & certificate, please contact us at telephone: (86-755) 8307 1443, or email: CN.Doccheck@sgs.com
 No.1 Workshop, M-10, Middle Section, Science & Technology Park, Nanshan District, Shenzhen, Guangdong, China 518057 t (86-755) 26012053 f (86-755) 26710594 www.sgs.com.cn
 中国·广东·深圳市南山区科技园中区M-10栋1号厂房 邮编: 518057 t (86-755) 26012053 f (86-755) 26710594 sgs.china@sgs.com

11a_TX_CH_100_Vertical-Peak

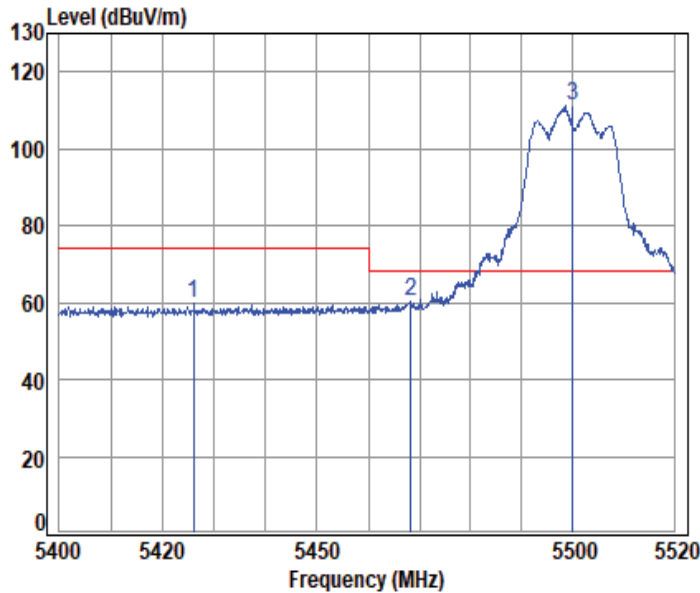

Condition: 3m VERTICAL

Job No : 01607WM

Mode : 5500 Band edge

: 5G Wi-Fi 11a

	Cable	Ant	Preamp	Read	Limit	Over		
Freq	Loss	Factor	Factor	Level	Level	Line	Limit	Remark
MHz	dB	dB/m	dB	dBuV	dBuV/m	dBuV/m	dB	
1	5426.055	10.61	32.85	30.63	47.09	59.92	74.00	-14.08 peak
2	5468.317	10.59	32.90	30.65	47.26	60.10	68.20	-8.10 peak
3	pp 5500.000	10.58	32.90	30.66	98.61	111.43	68.20	43.23 peak



11a_TX_CH_100_Vertical-Avg

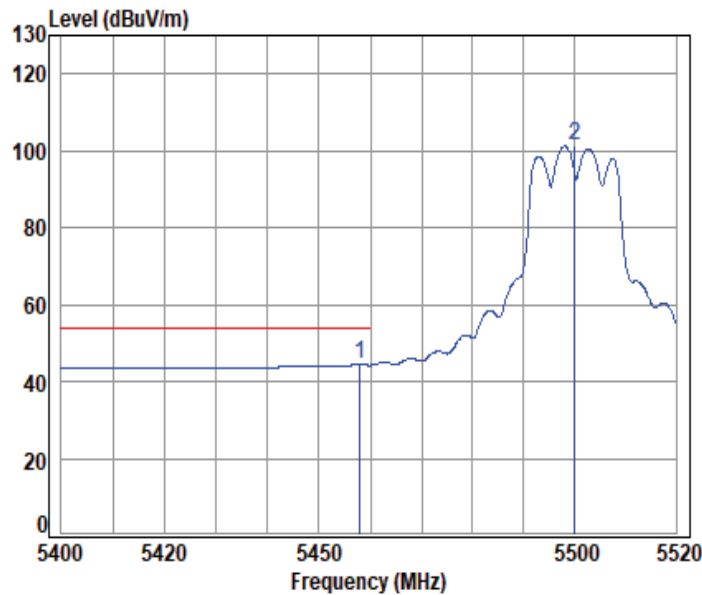

Condition: 3m VERTICAL

Job No : 01607WM

Mode : 5500 Band edge

: 5G Wi-Fi 11a

	Cable	Ant	Preamp	Read	Limit	Over			
Freq	Loss	Factor	Factor	Level	Level	Line	Limit	Remark	
MHz	dB	dB/m	dB	dBuV	dBuV/m	dBuV/m	dB		
1 pp 5457.991	10.60	32.90	30.64	31.58	44.44	54.00	-9.56	Average	
2 5500.000	10.58	32.90	30.66	88.31	101.13	-----	-----	Average	



Unless otherwise agreed in writing, this document is issued by the Company subject to its General Conditions of Service printed overleaf, available on request or accessible at <https://www.sgs.com/en/Terms-and-Conditions>. Attention is drawn to the limitation of liability, indemnification and jurisdiction issues defined therein. Any holder of this document is advised that information contained hereon reflects the Company's findings at the time of its intervention only and within the limits of Client's instructions, if any. The Company's sole responsibility is to its Client and this document does not exonerate parties to a transaction from exercising all their rights and obligations under the transaction documents. This document cannot be reproduced except in full, without prior written approval of the Company. Any unauthorized alteration, forgery or falsification of the content or appearance of this document is unlawful and offenders may be prosecuted to the fullest extent of the law. Unless otherwise stated the results shown in this test report refer only to the sample(s) tested and such sample(s) are retained for 30 days only.

Attention: To check the authenticity of testing /inspection report & certificate, please contact us at telephone: (86-755) 8307 1443, or email: CN.Doccheck@sgs.com
 No.1 Workshop, M-10, Middle Section, Science & Technology Park, Nanshan District, Shenzhen, Guangdong, China 518057 t (86-755) 26012053 f (86-755) 26710594 www.sgs.com.cn
 中国·广东·深圳市南山区科技园中区M-10栋1号厂房 邮编: 518057 t (86-755) 26012053 f (86-755) 26710594 sgs.china@sgs.com

11a_TX_CH_140_Horizontal-Peak

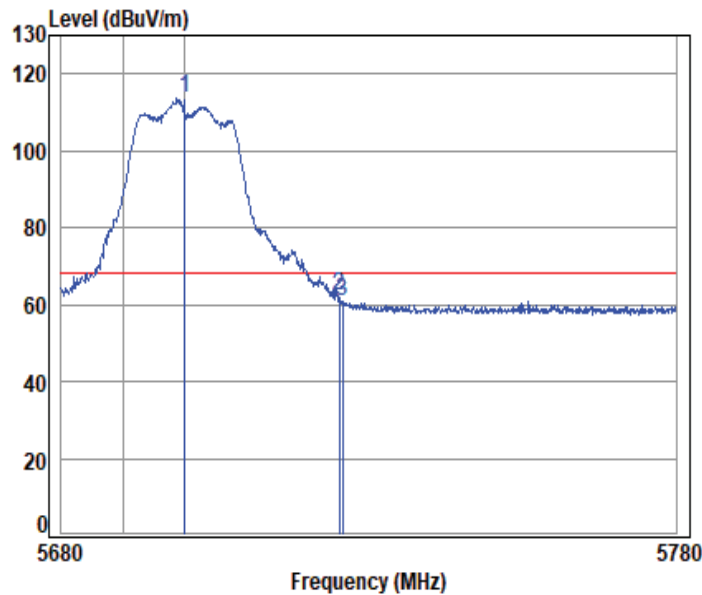

Condition: 3m HORIZONTAL

Job No : 01607WM

Mode : 5700 Band edge

: 5G Wi-Fi 11a

	Cable	Ant	Preamp	Read	Limit	Over		
Freq	Loss	Factor	Factor	Level	Level	Line	Limit	Remark
MHz	dB	dB/m	dB	dBuV	dBuV/m	dBuV/m	dB	
1 pp 5700.000	10.56	33.20	30.72	100.68	113.72	68.20	45.52	peak
2 5725.000	10.68	33.25	30.72	49.04	62.25	68.20	-5.95	peak
3 5725.583	10.68	33.25	30.72	47.62	60.83	68.20	-7.37	peak



Unless otherwise agreed in writing, this document is issued by the Company subject to its General Conditions of Service printed overleaf, available on request or accessible at <https://www.sgs.com/en/Terms-and-Conditions>. Attention is drawn to the limitation of liability, indemnification and jurisdiction issues defined therein. Any holder of this document is advised that information contained hereon reflects the Company's findings at the time of its intervention only and within the limits of Client's instructions, if any. The Company's sole responsibility is to its Client and this document does not exonerate parties to a transaction from exercising all their rights and obligations under the transaction documents. This document cannot be reproduced except in full, without prior written approval of the Company. Any unauthorized alteration, forgery or falsification of the content or appearance of this document is unlawful and offenders may be prosecuted to the fullest extent of the law. Unless otherwise stated the results shown in this test report refer only to the sample(s) tested and such sample(s) are retained for 30 days only.

Attention: To check the authenticity of testing /inspection report & certificate, please contact us at telephone: (86-755) 8307 1443, or email: CN.Doccheck@sgs.com

11a_TX_CH_140_Vertical-Peak

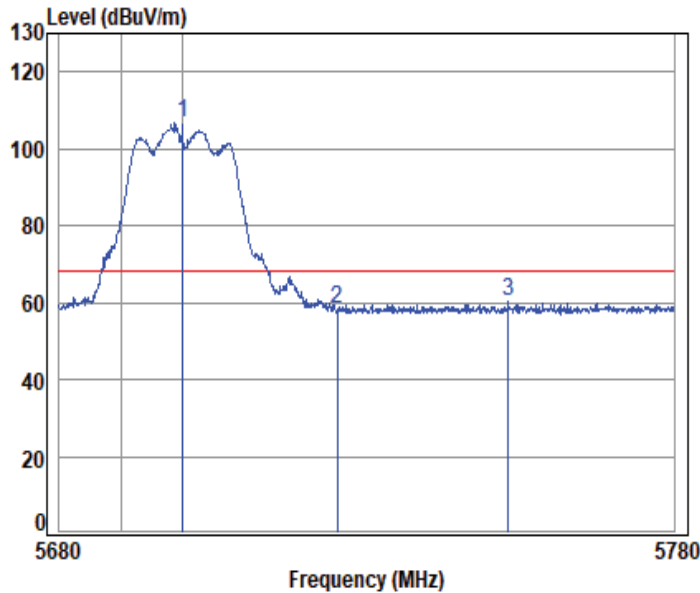

Condition: 3m VERTICAL

Job No : 01607WM

Mode : 5700 Band edge

: 5G Wi-Fi 11a

	Cable	Ant	Preamp	Read	Limit	Over		
Freq	Loss	Factor	Factor	Level	Level	Line	Limit	Remark
MHz	dB	dB/m	dB	dBuV	dBuV/m	dBuV/m	dB	
1 pp 5700.000	10.56	33.20	30.72	93.61	106.65	68.20	38.45	peak
2 5725.000	10.68	33.25	30.72	45.02	58.23	68.20	-9.97	peak
3 5752.828	10.80	33.31	30.73	47.05	60.43	68.20	-7.77	peak



Unless otherwise agreed in writing, this document is issued by the Company subject to its General Conditions of Service printed overleaf, available on request or accessible at <https://www.sgs.com/en/Terms-and-Conditions>. Attention is drawn to the limitation of liability, indemnification and jurisdiction issues defined therein. Any holder of this document is advised that information contained hereon reflects the Company's findings at the time of its intervention only and within the limits of Client's instructions, if any. The Company's sole responsibility is to its Client and this document does not exonerate parties to a transaction from exercising all their rights and obligations under the transaction documents. This document cannot be reproduced except in full, without prior written approval of the Company. Any unauthorized alteration, forgery or falsification of the content or appearance of this document is unlawful and offenders may be prosecuted to the fullest extent of the law. Unless otherwise stated the results shown in this test report refer only to the sample(s) tested and such sample(s) are retained for 30 days only.

Attention: To check the authenticity of testing /inspection report & certificate, please contact us at telephone: (86-755) 8307 1443, or email: CN.Doccheck@sgs.com
 No.1 Workshop, M-10, Middle Section, Science & Technology Park, Nanshan District, Shenzhen, Guangdong, China 518057 t (86-755) 26012053 f (86-755) 26710594 www.sgsgroup.com.cn
 中国·广东·深圳市南山区科技园中区M-10栋1号厂房 邮编: 518057 t (86-755) 26012053 f (86-755) 26710594 sgs.china@sgs.com

11ac_VHT(20M)_TX_CH_100_Horizontal-Peak

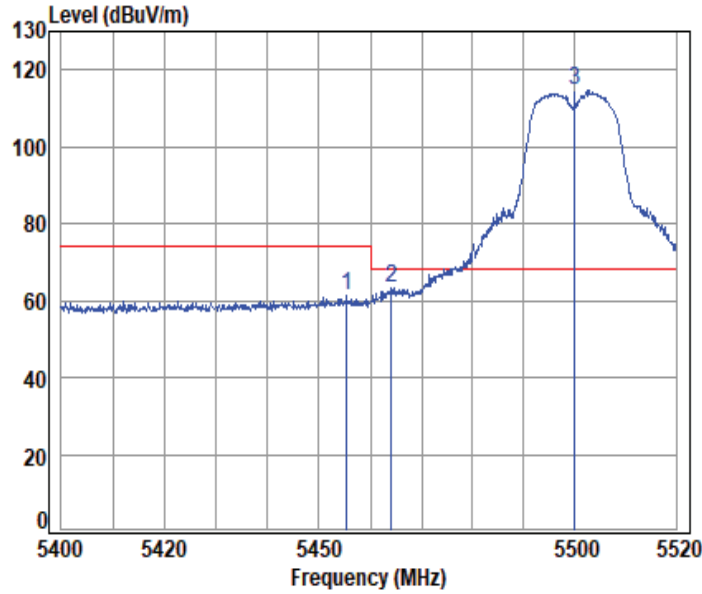

Condition: 3m HORIZONTAL

Job No : 01607WM

Mode : 5500 Band edge

: 5G Wi-Fi 11ac20

	Cable	Ant	Preamp	Read	Limit	Over			
Freq	Loss	Factor	Factor	Level	Level	Line	Limit	Remark	
MHz	dB	dB/m	dB	dBuV	dBuV/m	dBuV/m	dB		
1	5455.352	10.60	32.90	30.64	48.44	61.30	74.00	-12.70 peak	
2	5464.112	10.59	32.90	30.65	50.22	63.06	68.20	-5.14 peak	
3	pp 5500.000	10.58	32.90	30.66	101.77	114.59	68.20	46.39 peak	



Unless otherwise agreed in writing, this document is issued by the Company subject to its General Conditions of Service printed overleaf, available on request or accessible at <https://www.sgs.com/en/Terms-and-Conditions>. Attention is drawn to the limitation of liability, indemnification and jurisdiction issues defined therein. Any holder of this document is advised that information contained hereon reflects the Company's findings at the time of its intervention only and within the limits of Client's instructions, if any. The Company's sole responsibility is to its Client and this document does not exonerate parties to a transaction from exercising all their rights and obligations under the transaction documents. This document cannot be reproduced except in full, without prior written approval of the Company. Any unauthorized alteration, forgery or falsification of the content or appearance of this document is unlawful and offenders may be prosecuted to the fullest extent of the law. Unless otherwise stated the results shown in this test report refer only to the sample(s) tested and such sample(s) are retained for 30 days only.

Attention: To check the authenticity of testing /inspection report & certificate, please contact us at telephone: (86-755) 8307 1443, or email: CN.Doccheck@sgs.com
 No.1 Workshop, M-10, Middle Section, Science & Technology Park, Nanshan District, Shenzhen, Guangdong, China 518057 t (86-755) 26012053 f (86-755) 26710594 www.sgs.com.cn
 中国·广东·深圳市南山区科技园中区M-10栋1号厂房 邮编: 518057 t (86-755) 26012053 f (86-755) 26710594 sgs.china@sgs.com

11ac_VHT(20M)_TX_CH_100_Horizontal-Avg

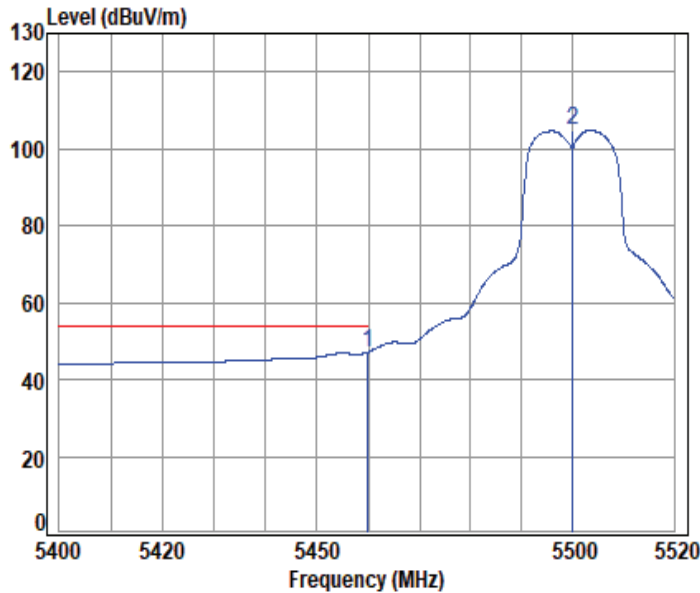

Condition: 3m HORIZONTAL

Job No : 01607WM

Mode : 5500 Band edge

: 5G Wi-Fi 11ac20

	Cable	Ant	Preamp	Read	Limit	Over			
Freq	Loss	Factor	Factor	Level	Level	Line	Limit	Remark	
MHz	dB	dB/m	dB	dBuV	dBuV/m	dBuV/m	dB		
1 pp 5459.910	10.60	32.90	30.64	34.24	47.10	54.00	-6.90	Average	
2 5500.000	10.58	32.90	30.66	92.05	104.87	-----	-----	Average	



Unless otherwise agreed in writing, this document is issued by the Company subject to its General Conditions of Service printed overleaf, available on request or accessible at <https://www.sgs.com/en/Terms-and-Conditions>. Attention is drawn to the limitation of liability, indemnification and jurisdiction issues defined therein. Any holder of this document is advised that information contained hereon reflects the Company's findings at the time of its intervention only and within the limits of Client's instructions, if any. The Company's sole responsibility is to its Client and this document does not exonerate parties to a transaction from exercising all their rights and obligations under the transaction documents. This document cannot be reproduced except in full, without prior written approval of the Company. Any unauthorized alteration, forgery or falsification of the content or appearance of this document is unlawful and offenders may be prosecuted to the fullest extent of the law. Unless otherwise stated the results shown in this test report refer only to the sample(s) tested and such sample(s) are retained for 30 days only.

Attention: To check the authenticity of testing /inspection report & certificate, please contact us at telephone: (86-755) 8307 1443, or email: CN.Doccheck@sgs.com
 No.1 Workshop, M-10, Middle Section, Science & Technology Park, Nanshan District, Shenzhen, Guangdong, China 518057 t (86-755) 26012053 f (86-755) 26710594 www.sgs.com.cn
 中国·广东·深圳市南山区科技园中区M-10栋1号厂房 邮编: 518057 t (86-755) 26012053 f (86-755) 26710594 sgs.china@sgs.com

11ac_VHT(20M)_TX_CH_100_Vertical-Peak

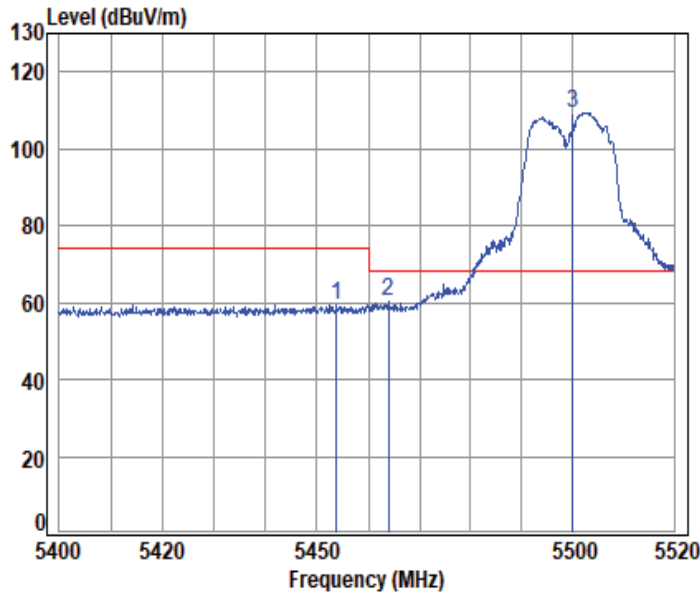

Condition: 3m VERTICAL

Job No : 01607WM

Mode : 5500 Band edge

: 5G Wi-Fi 11ac20

	Cable	Ant	Preamp	Read	Limit	Over		
Freq	Loss	Factor	Factor	Level	Level	Line	Limit	Remark
MHz	dB	dB/m	dB	dBuV	dBuV/m	dBuV/m	dB	
1	5453.793	10.60	32.90	30.64	46.60	59.46	74.00	-14.54 peak
2	5463.872	10.59	32.90	30.65	47.26	60.10	68.20	-8.10 peak
3	pp 5500.000	10.58	32.90	30.66	96.59	109.41	68.20	41.21 peak



Unless otherwise agreed in writing, this document is issued by the Company subject to its General Conditions of Service printed overleaf, available on request or accessible at <https://www.sgs.com/en/Terms-and-Conditions>. Attention is drawn to the limitation of liability, indemnification and jurisdiction issues defined therein. Any holder of this document is advised that information contained hereon reflects the Company's findings at the time of its intervention only and within the limits of Client's instructions, if any. The Company's sole responsibility is to its Client and this document does not exonerate parties to a transaction from exercising all their rights and obligations under the transaction documents. This document cannot be reproduced except in full, without prior written approval of the Company. Any unauthorized alteration, forgery or falsification of the content or appearance of this document is unlawful and offenders may be prosecuted to the fullest extent of the law. Unless otherwise stated the results shown in this test report refer only to the sample(s) tested and such sample(s) are retained for 30 days only.

Attention: To check the authenticity of testing /inspection report & certificate, please contact us at telephone: (86-755) 8307 1443, or email: CN.Doccheck@sgs.com
 No.1 Workshop, M-10, Middle Section, Science & Technology Park, Nanshan District, Shenzhen, Guangdong, China 518057 t (86-755) 26012053 f (86-755) 26710594 www.sgs.com.cn
 中国·广东·深圳市南山区科技园中区M-10栋1号厂房 邮编: 518057 t (86-755) 26012053 f (86-755) 26710594 sgs.china@sgs.com

11ac_VHT(20M)_TX_CH_100_Vertical-Avg

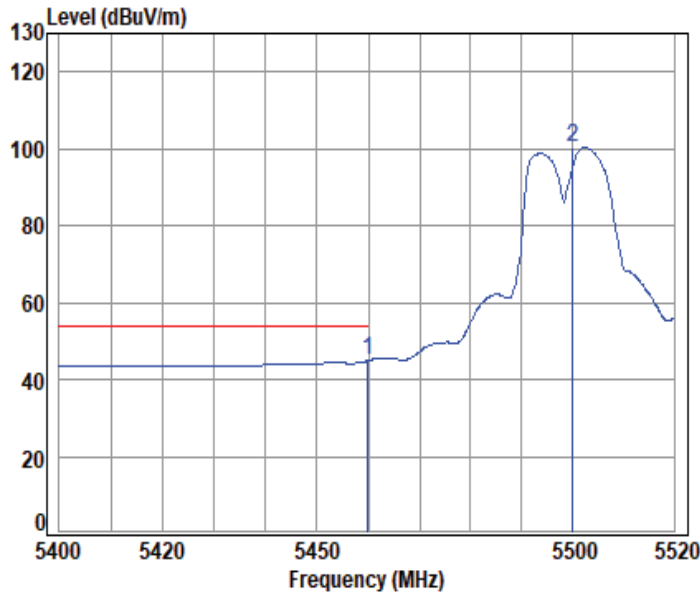

Condition: 3m VERTICAL

Job No : 01607WM

Mode : 5500 Band edge

: 5G Wi-Fi 11ac20

	Cable	Ant	Preamp	Read	Limit	Over			
Freq	Loss	Factor	Factor	Level	Level	Line	Limit	Remark	
MHz	dB	dB/m	dB	dBuV	dBuV/m	dBuV/m	dB		
1 pp 5459.910	10.60	32.90	30.64	32.02	44.88	54.00	-9.12	Average	
2 5500.000	10.58	32.90	30.66	87.50	100.32	-----	-----	Average	



Unless otherwise agreed in writing, this document is issued by the Company subject to its General Conditions of Service printed overleaf, available on request or accessible at <https://www.sgs.com/en/Terms-and-Conditions>. Attention is drawn to the limitation of liability, indemnification and jurisdiction issues defined therein. Any holder of this document is advised that information contained hereon reflects the Company's findings at the time of its intervention only and within the limits of Client's instructions, if any. The Company's sole responsibility is to its Client and this document does not exonerate parties to a transaction from exercising all their rights and obligations under the transaction documents. This document cannot be reproduced except in full, without prior written approval of the Company. Any unauthorized alteration, forgery or falsification of the content or appearance of this document is unlawful and offenders may be prosecuted to the fullest extent of the law. Unless otherwise stated the results shown in this test report refer only to the sample(s) tested and such sample(s) are retained for 30 days only.

Attention: To check the authenticity of testing /inspection report & certificate, please contact us at telephone: (86-755) 8307 1443, or email: CN.Doccheck@sgs.com
 No.1 Workshop, M-10, Middle Section, Science & Technology Park, Nanshan District, Shenzhen, Guangdong, China 518057 t (86-755) 26012053 f (86-755) 26710594 www.sgs.com.cn
 中国·广东·深圳市南山区科技园中区M-10栋1号厂房 邮编: 518057 t (86-755) 26012053 f (86-755) 26710594 sgs.china@sgs.com

11ac_VHT(20M)_TX_CH_140_Horizontal-Peak

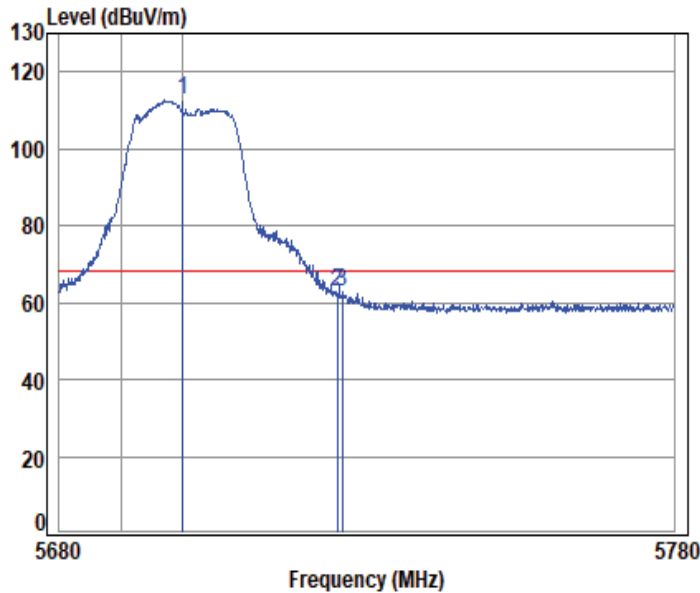

Condition: 3m HORIZONTAL

Job No : 01607WM

Mode : 5700 Band edge

: 5G Wi-Fi 11ac20

	Cable	Ant	Preamp	Read	Limit	Over		
Freq	Loss	Factor	Factor	Level	Level	Line	Limit	Remark
MHz	dB	dB/m	dB	dBuV	dBuV/m	dBuV/m	dB	
1 pp 5700.000	10.56	33.20	30.72	99.66	112.70	68.20	44.50	peak
2 5725.000	10.68	33.25	30.72	49.54	62.75	68.20	-5.45	peak
3 5725.883	10.68	33.25	30.72	49.46	62.67	68.20	-5.53	peak



11ac_VHT(20M)_TX_CH_140_Vertical-Peak

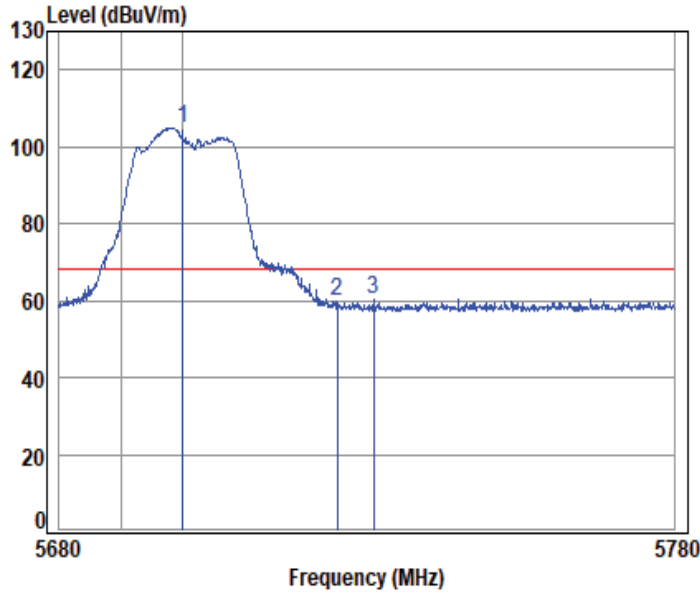

Condition: 3m VERTICAL

Job No : 01607WM

Mode : 5700 Band edge

: 5G Wi-Fi 11ac20

	Cable	Ant	Preamp	Read	Limit	Over			
Freq	Loss	Factor	Factor	Level	Level	Line	Limit	Remark	
MHz	dB	dB/m	dB	dBuV	dBuV/m	dBuV/m	dB		
1 pp 5700.000	10.56	33.20	30.72	91.97	105.01	68.20	36.81	peak	
2 5725.000	10.68	33.25	30.72	46.37	59.58	68.20	-8.62	peak	
3 5730.982	10.70	33.26	30.72	46.93	60.17	68.20	-8.03	peak	



Unless otherwise agreed in writing, this document is issued by the Company subject to its General Conditions of Service printed overleaf, available on request or accessible at <https://www.sgs.com/en/Terms-and-Conditions>. Attention is drawn to the limitation of liability, indemnification and jurisdiction issues defined therein. Any holder of this document is advised that information contained hereon reflects the Company's findings at the time of its intervention only and within the limits of Client's instructions, if any. The Company's sole responsibility is to its Client and this document does not exonerate parties to a transaction from exercising all their rights and obligations under the transaction documents. This document cannot be reproduced except in full, without prior written approval of the Company. Any unauthorized alteration, forgery or falsification of the content or appearance of this document is unlawful and offenders may be prosecuted to the fullest extent of the law. Unless otherwise stated the results shown in this test report refer only to the sample(s) tested and such sample(s) are retained for 30 days only.

Attention: To check the authenticity of testing /inspection report & certificate, please contact us at telephone: (86-755) 8307 1443, or email: CN.Doccheck@sgs.com
 No.1 Workshop, M-10, Middle Section, Science & Technology Park, Nanshan District, Shenzhen, Guangdong, China 518057 t (86-755) 26012053 f (86-755) 26710594 www.sgs.com.cn
 中国·广东·深圳市南山区科技园中区M-10栋1号厂房 邮编: 518057 t (86-755) 26012053 f (86-755) 26710594 sgs.china@sgs.com

11ac_VHT(40M)_TX_CH_3.45_Horizontal-Peak

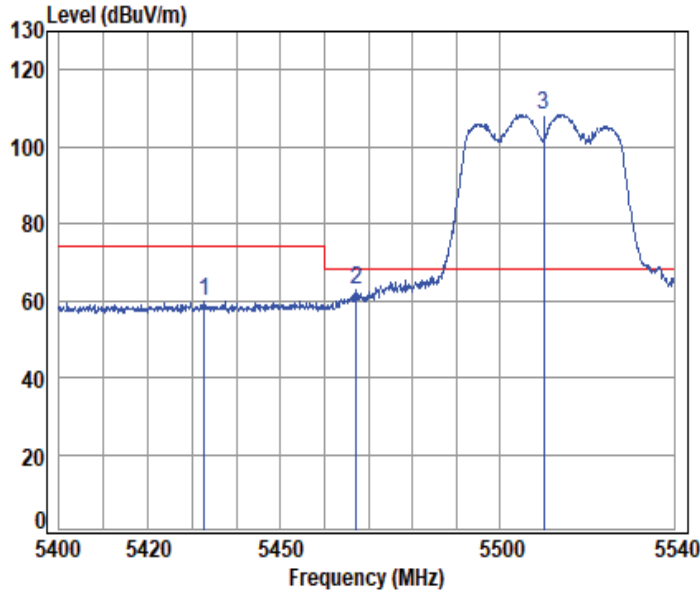

Condition: 3m HORIZONTAL

Job No : 01607WM

Mode : 5510 Band edge

: 5G Wi-Fi 11ac40

	Cable	Ant	Preamp	Read	Limit	Over			
Freq	Loss	Factor	Factor	Level	Level	Line	Limit	Remark	
MHz	dB	dB/m	dB	dBuV	dBuV/m	dBuV/m	dB		
1	5432.718	10.61	32.87	30.64	46.94	59.78	74.00	-14.22	peak
2	5467.173	10.59	32.90	30.65	49.93	62.77	68.20	-5.43	peak
3	pp 5510.000	10.56	32.90	30.66	95.44	108.24	68.20	40.04	peak



Unless otherwise agreed in writing, this document is issued by the Company subject to its General Conditions of Service printed overleaf, available on request or accessible at <https://www.sgs.com/en/Terms-and-Conditions>. Attention is drawn to the limitation of liability, indemnification and jurisdiction issues defined therein. Any holder of this document is advised that information contained hereon reflects the Company's findings at the time of its intervention only and within the limits of Client's instructions, if any. The Company's sole responsibility is to its Client and this document does not exonerate parties to a transaction from exercising all their rights and obligations under the transaction documents. This document cannot be reproduced except in full, without prior written approval of the Company. Any unauthorized alteration, forgery or falsification of the content or appearance of this document is unlawful and offenders may be prosecuted to the fullest extent of the law. Unless otherwise stated the results shown in this test report refer only to the sample(s) tested and such sample(s) are retained for 30 days only.

11ac_VHT(40M)_TX_CH_3.45_Horizontal-Avg

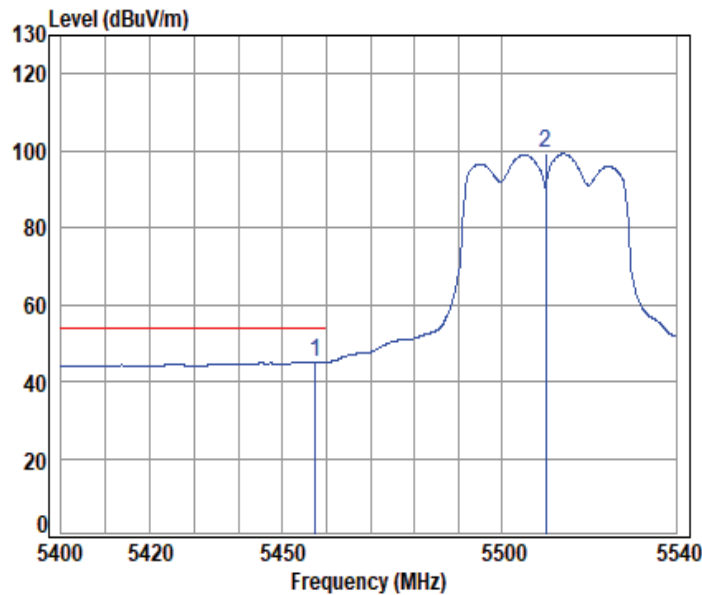

Condition: 3m HORIZONTAL

Job No : 01607WM

Mode : 5510 Band edge

: 5G Wi-Fi 11ac40

	Cable	Ant	Preamp	Read	Limit	Over			
Freq	Loss	Factor	Factor	Level	Level	Line	Limit	Remark	
MHz	dB	dB/m	dB	dBuV	dBuV/m	dBuV/m	dB		
1 pp 5457.526	10.60	32.90	30.64	32.26	45.12	54.00	-8.88	Average	
2 5510.000	10.56	32.90	30.66	86.34	99.14	-----	-----	Average	



Unless otherwise agreed in writing, this document is issued by the Company subject to its General Conditions of Service printed overleaf, available on request or accessible at <https://www.sgs.com/en/Terms-and-Conditions>. Attention is drawn to the limitation of liability, indemnification and jurisdiction issues defined therein. Any holder of this document is advised that information contained hereon reflects the Company's findings at the time of its intervention only and within the limits of Client's instructions, if any. The Company's sole responsibility is to its Client and this document does not exonerate parties to a transaction from exercising all their rights and obligations under the transaction documents. This document cannot be reproduced except in full, without prior written approval of the Company. Any unauthorized alteration, forgery or falsification of the content or appearance of this document is unlawful and offenders may be prosecuted to the fullest extent of the law. Unless otherwise stated the results shown in this test report refer only to the sample(s) tested and such sample(s) are retained for 30 days only.

Attention: To check the authenticity of testing /inspection report & certificate, please contact us at telephone: (86-755) 8307 1443, or email: CN.Doccheck@sgs.com
 No.1 Workshop, M-10, Middle Section, Science & Technology Park, Nanshan District, Shenzhen, Guangdong, China 518057 t (86-755) 26012053 f (86-755) 26710594 www.sgsgroup.com.cn
 中国·广东·深圳市南山区科技园中区M-10栋1号厂房 邮编: 518057 t (86-755) 26012053 f (86-755) 26710594 sgs.china@sgs.com

11ac_VHT(40M)_TX_CH_3.45_Verical-Peak

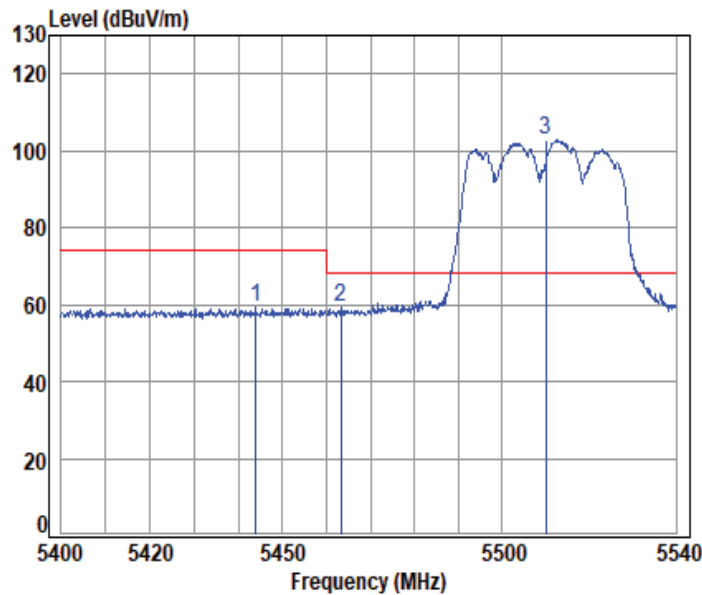

Condition: 3m VERTICAL

Job No : 01607WM

Mode : 5510 Band edge

: 5G Wi-Fi 11ac40

	Cable	Ant	Preamp	Read	Limit	Over			
Freq	Loss	Factor	Factor	Level	Level	Line	Limit	Remark	
MHz	dB	dB/m	dB	dBuV	dBuV/m	dBuV/m	dB		
1	5443.993	10.60	32.89	30.64	46.37	59.22	74.00	-14.78	peak
2	5463.256	10.59	32.90	30.65	46.44	59.28	68.20	-8.92	peak
3	pp 5510.000	10.56	32.90	30.66	90.16	102.96	68.20	34.76	peak



Unless otherwise agreed in writing, this document is issued by the Company subject to its General Conditions of Service printed overleaf, available on request or accessible at <https://www.sgs.com/en/Terms-and-Conditions>. Attention is drawn to the limitation of liability, indemnification and jurisdiction issues defined therein. Any holder of this document is advised that information contained hereon reflects the Company's findings at the time of its intervention only and within the limits of Client's instructions, if any. The Company's sole responsibility is to its Client and this document does not exonerate parties to a transaction from exercising all their rights and obligations under the transaction documents. This document cannot be reproduced except in full, without prior written approval of the Company. Any unauthorized alteration, forgery or falsification of the content or appearance of this document is unlawful and offenders may be prosecuted to the fullest extent of the law. Unless otherwise stated the results shown in this test report refer only to the sample(s) tested and such sample(s) are retained for 30 days only.

Attention: To check the authenticity of testing /inspection report & certificate, please contact us at telephone: (86-755) 8307 1443, or email: CN.Doccheck@sgs.com
 No.1 Workshop, M-10, Middle Section, Science & Technology Park, Nanshan District, Shenzhen, Guangdong, China 518057 t (86-755) 26012053 f (86-755) 26710594 www.sgs.com.cn
 中国·广东·深圳市南山区科技园中区M-10栋1号厂房 邮编: 518057 t (86-755) 26012053 f (86-755) 26710594 sgs.china@sgs.com

11ac_VHT(40M)_TX_CH_3.45_Verical-Avg

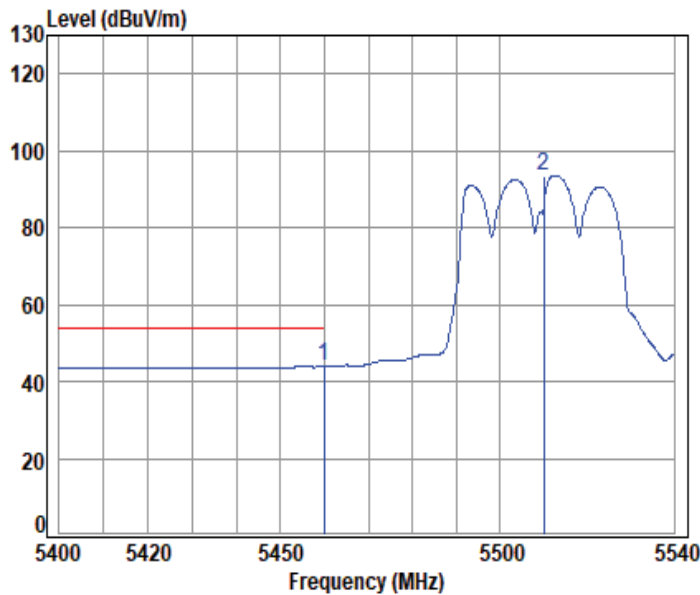

Condition: 3m VERTICAL

Job No : 01607WM

Mode : 5510 Band edge

: 5G Wi-Fi 11ac40

	Cable	Ant	Preamp	Read	Limit	Over			
Freq	Loss	Factor	Factor	Level	Level	Line	Limit	Remark	
MHz	dB	dB/m	dB	dBuV	dBuV/m	dBuV/m	dB		
1 pp 5459.901	10.60	32.90	30.64	30.95	43.81	54.00	-10.19	Average	
2 5510.000	10.56	32.90	30.66	80.83	93.63	-----	-----	Average	



11ac_VHT(40M)_TX_CH_134_Horizontal-Peak

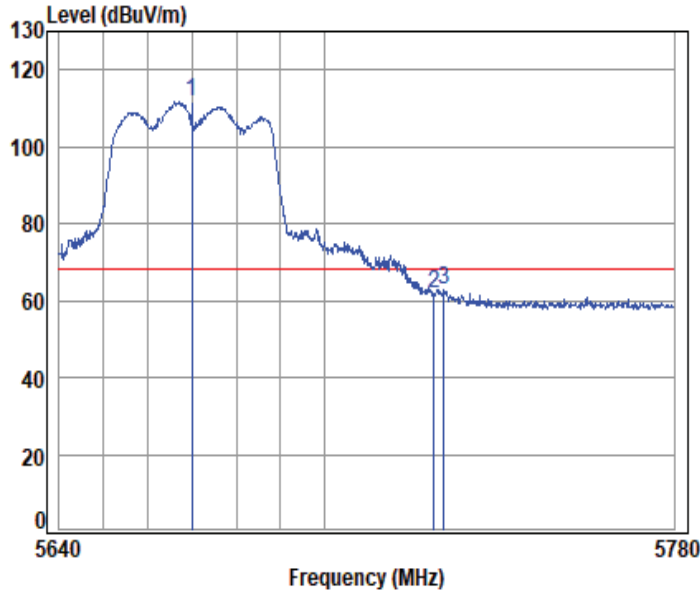

Condition: 3m HORIZONTAL

Job No : 01607WM

Mode : 5670 Band edge

: 5G Wi-Fi 11ac40

	Cable	Ant	Preamp	Read	Limit	Over		
Freq	Loss	Factor	Factor	Level	Level	Line	Limit	Remark
MHz	dB	dB/m	dB	dBuV	dBuV/m	dBuV/m	dB	
1 pp 5670.000	10.52	33.14	30.71	98.59	111.54	68.20	43.34	peak
2 5725.000	10.68	33.25	30.72	48.62	61.83	68.20	-6.37	peak
3 5727.238	10.69	33.25	30.72	49.72	62.94	68.20	-5.26	peak



11ac_VHT(40M)_TX_CH_134_Vertical-Peak

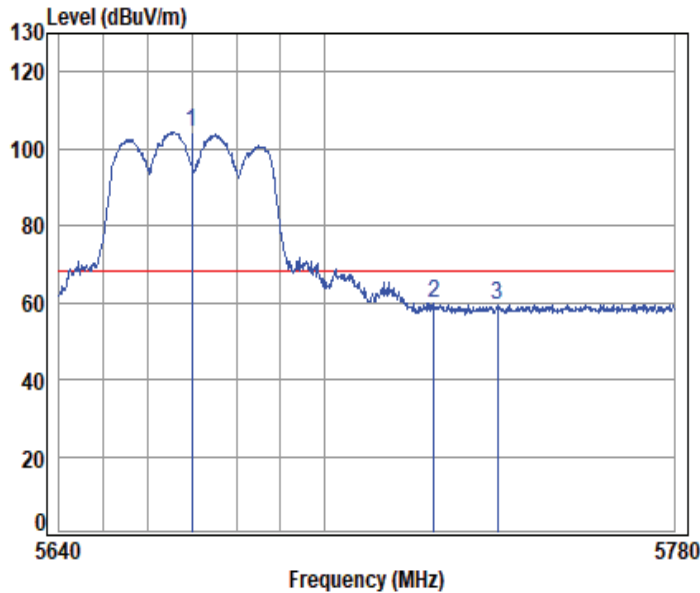

Condition: 3m VERTICAL

Job No : 01607WM

Mode : 5670 Band edge

: 5G Wi-Fi 11ac40

	Cable	Ant	Preamp	Read	Limit	Over		
Freq	Loss	Factor	Factor	Level	Level	Line	Limit	Remark
MHz	dB	dB/m	dB	dBuV	dBuV/m	dBuV/m	dB	
1 pp 5670.000	10.52	33.14	30.71	91.43	104.38	68.20	36.18	peak
2 5725.000	10.68	33.25	30.72	46.61	59.82	68.20	-8.38	peak
3 5739.468	10.74	33.28	30.73	46.24	59.53	68.20	-8.67	peak



Unless otherwise agreed in writing, this document is issued by the Company subject to its General Conditions of Service printed overleaf, available on request or accessible at <https://www.sgs.com/en/Terms-and-Conditions>. Attention is drawn to the limitation of liability, indemnification and jurisdiction issues defined therein. Any holder of this document is advised that information contained hereon reflects the Company's findings at the time of its intervention only and within the limits of Client's instructions, if any. The Company's sole responsibility is to its Client and this document does not exonerate parties to a transaction from exercising all their rights and obligations under the transaction documents. This document cannot be reproduced except in full, without prior written approval of the Company. Any unauthorized alteration, forgery or falsification of the content or appearance of this document is unlawful and offenders may be prosecuted to the fullest extent of the law. Unless otherwise stated the results shown in this test report refer only to the sample(s) tested and such sample(s) are retained for 30 days only.

Attention: To check the authenticity of testing /inspection report & certificate, please contact us at telephone: (86-755) 8307 1443, or email: CN.Doccheck@sgs.com
 No.1 Workshop, M-10, Middle Section, Science & Technology Park, Nanshan District, Shenzhen, Guangdong, China 518057 t (86-755) 26012053 f (86-755) 26710594 www.sgs.com.cn
 中国·广东·深圳市南山区科技园中区M-10栋1号厂房 邮编: 518057 t (86-755) 26012053 f (86-755) 26710594 sgs.china@sgs.com

11ac_VHT(80M)_TX_CH_106_Horizontal-Peak

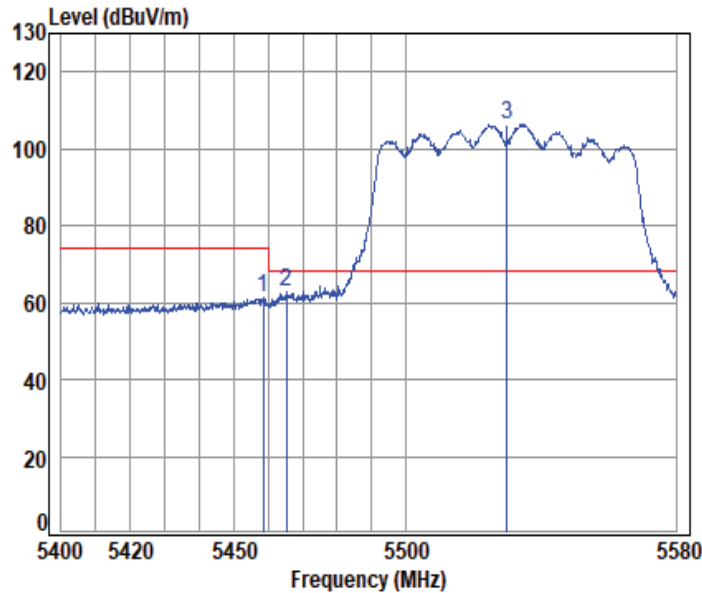

Condition: 3m HORIZONTAL

Job No : 01607WM

Mode : 5530 Band edge

: 5G Wi-Fi 11ac80

	Cable	Ant	Preamp	Read	Limit	Over		
Freq	Loss	Factor	Factor	Level	Level	Line	Limit	Remark
MHz	dB	dB/m	dB	dBuV	dBuV/m	dBuV/m	dB	
1	5458.570	10.60	32.90	30.64	48.59	61.45	74.00	-12.55 peak
2	5465.196	10.59	32.90	30.65	49.82	62.66	68.20	-5.54 peak
3	pp 5530.000	10.53	32.90	30.67	93.75	106.51	68.20	38.31 peak



Unless otherwise agreed in writing, this document is issued by the Company subject to its General Conditions of Service printed overleaf, available on request or accessible at <https://www.sgs.com/en/Terms-and-Conditions>. Attention is drawn to the limitation of liability, indemnification and jurisdiction issues defined therein. Any holder of this document is advised that information contained hereon reflects the Company's findings at the time of its intervention only and within the limits of Client's instructions, if any. The Company's sole responsibility is to its Client and this document does not exonerate parties to a transaction from exercising all their rights and obligations under the transaction documents. This document cannot be reproduced except in full, without prior written approval of the Company. Any unauthorized alteration, forgery or falsification of the content or appearance of this document is unlawful and offenders may be prosecuted to the fullest extent of the law. Unless otherwise stated the results shown in this test report refer only to the sample(s) tested and such sample(s) are retained for 30 days only.

Attention: To check the authenticity of testing /inspection report & certificate, please contact us at telephone: (86-755) 8307 1443, or email: CN.Doccheck@sgs.com
 No.1 Workshop, M-10, Middle Section, Science & Technology Park, Nanshan District, Shenzhen, Guangdong, China 518057 t (86-755) 26012053 f (86-755) 26710594 www.sgs.com.cn
 中国·广东·深圳市南山区科技园中区M-10栋1号厂房 邮编: 518057 t (86-755) 26012053 f (86-755) 26710594 sgs.china@sgs.com

11ac_VHT(80M)_TX_CH_106_Horizontal-Avg

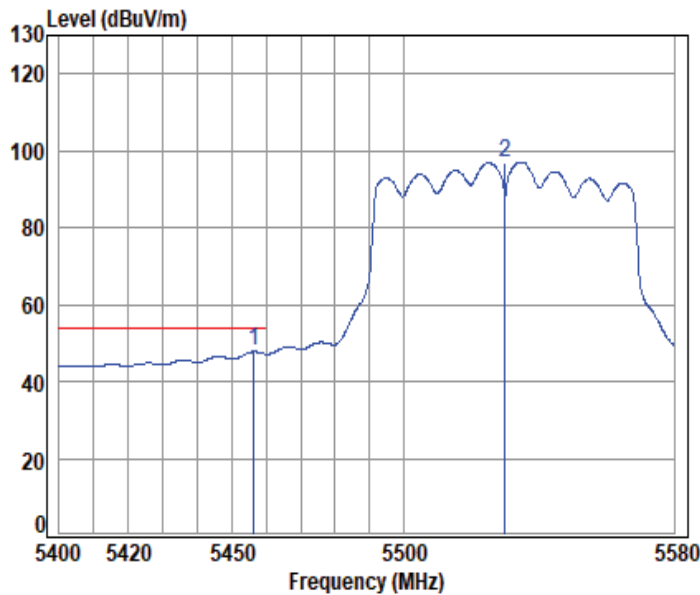

Condition: 3m HORIZONTAL

Job No : 01607WM

Mode : 5530 Band edge

: 5G Wi-Fi 11ac80

	Cable	Ant	Preamp	Read	Limit	Over			
Freq	Loss	Factor	Factor	Level	Level	Line	Limit	Remark	
MHz	dB	dB/m	dB	dBuV	dBuV/m	dBuV/m	dB		
1 pp 5456.422	10.60	32.90	30.64	34.90	47.76	54.00	-6.24	Average	
2 5530.000	10.53	32.90	30.67	84.35	97.11	-----	-----	Average	



Unless otherwise agreed in writing, this document is issued by the Company subject to its General Conditions of Service printed overleaf, available on request or accessible at <https://www.sgs.com/en/Terms-and-Conditions>. Attention is drawn to the limitation of liability, indemnification and jurisdiction issues defined therein. Any holder of this document is advised that information contained hereon reflects the Company's findings at the time of its intervention only and within the limits of Client's instructions, if any. The Company's sole responsibility is to its Client and this document does not exonerate parties to a transaction from exercising all their rights and obligations under the transaction documents. This document cannot be reproduced except in full, without prior written approval of the Company. Any unauthorized alteration, forgery or falsification of the content or appearance of this document is unlawful and offenders may be prosecuted to the fullest extent of the law. Unless otherwise stated the results shown in this test report refer only to the sample(s) tested and such sample(s) are retained for 30 days only.

Attention: To check the authenticity of testing /inspection report & certificate, please contact us at telephone: (86-755) 8307 1443, or email: CN.Doccheck@sgs.com
 No.1 Workshop, M-10, Middle Section, Science & Technology Park, Nanshan District, Shenzhen, Guangdong, China 518057 t (86-755) 26012053 f (86-755) 26710594 www.sgs.com.cn
 中国·广东·深圳市南山区科技园中区M-10栋1号厂房 邮编: 518057 t (86-755) 26012053 f (86-755) 26710594 sgs.china@sgs.com

11ac_VHT(80M)_TX_CH_106_Vertical-Peak

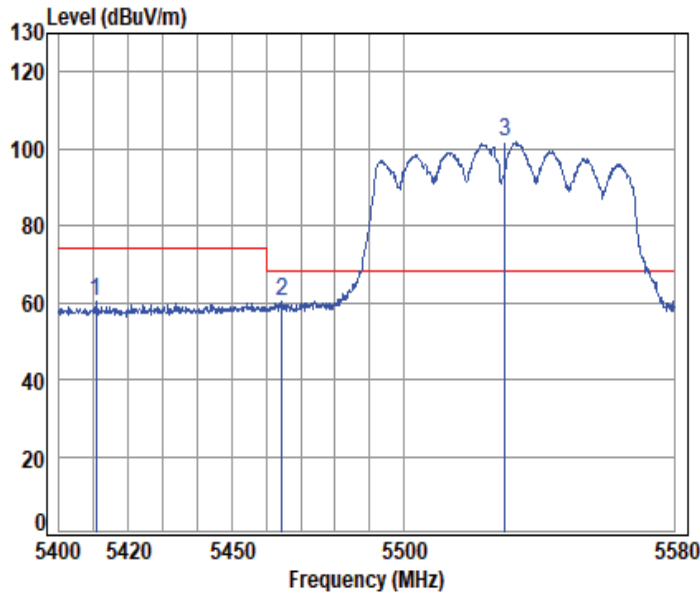

Condition: 3m VERTICAL

Job No : 01607WM

Mode : 5530 Band edge

: 5G Wi-Fi 11ac80

	Cable	Ant	Preamp	Read	Limit	Over			
Freq	Loss	Factor	Factor	Level	Level	Line	Limit	Remark	
MHz	dB	dB/m	dB	dBuV	dBuV/m	dBuV/m	dB		
1	5410.634	10.62	32.82	30.63	47.30	60.11	74.00	-13.89 peak	
2	5464.479	10.59	32.90	30.65	47.35	60.19	68.20	-8.01 peak	
3 pp	5530.000	10.53	32.90	30.67	89.08	101.84	68.20	33.64 peak	



Unless otherwise agreed in writing, this document is issued by the Company subject to its General Conditions of Service printed overleaf, available on request or accessible at <https://www.sgs.com/en/Terms-and-Conditions>. Attention is drawn to the limitation of liability, indemnification and jurisdiction issues defined therein. Any holder of this document is advised that information contained hereon reflects the Company's findings at the time of its intervention only and within the limits of Client's instructions, if any. The Company's sole responsibility is to its Client and this document does not exonerate parties to a transaction from exercising all their rights and obligations under the transaction documents. This document cannot be reproduced except in full, without prior written approval of the Company. Any unauthorized alteration, forgery or falsification of the content or appearance of this document is unlawful and offenders may be prosecuted to the fullest extent of the law. Unless otherwise stated the results shown in this test report refer only to the sample(s) tested and such sample(s) are retained for 30 days only.

Attention: To check the authenticity of testing /inspection report & certificate, please contact us at telephone: (86-755) 8307 1443, or email: CN.Doccheck@sgs.com
 No.1 Workshop, M-10, Middle Section, Science & Technology Park, Nanshan District, Shenzhen, Guangdong, China 518057 t (86-755) 26012053 f (86-755) 26710594 www.sgs.com.cn
 中国·广东·深圳市南山区科技园中区M-10栋1号厂房 邮编: 518057 t (86-755) 26012053 f (86-755) 26710594 sgs.china@sgs.com

11ac_VHT(80M)_TX_CH_106_Vertical-Avg

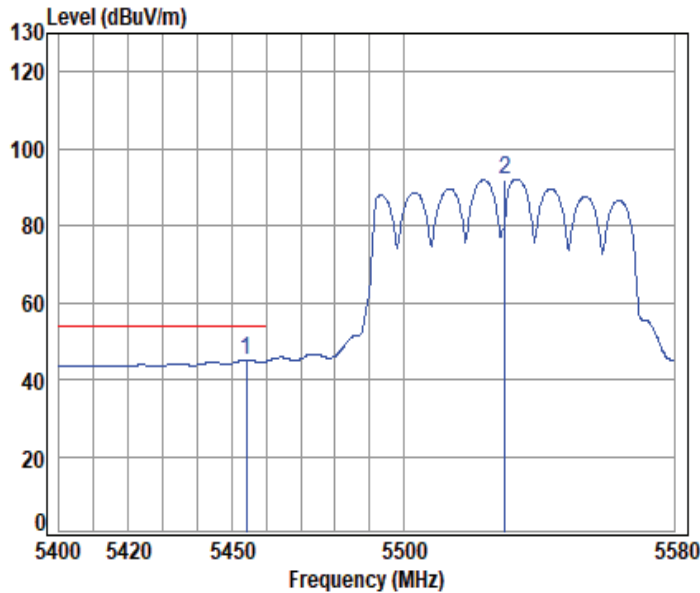

Condition: 3m VERTICAL

Job No : 01607WM

Mode : 5530 Band edge

: 5G Wi-Fi 11ac80

	Cable	Ant	Preamp	Read	Limit	Over			
Freq	Loss	Factor	Factor	Level	Level	Line	Limit	Remark	
MHz	dB	dB/m	dB	dBuV	dBuV/m	dBuV/m	dB		
1 pp 5454.276	10.60	32.90	30.64	32.19	45.05	54.00	-8.95	Average	
2 5530.000	10.53	32.90	30.67	79.38	92.14	-----	-----	Average	



Unless otherwise agreed in writing, this document is issued by the Company subject to its General Conditions of Service printed overleaf, available on request or accessible at <https://www.sgs.com/en/Terms-and-Conditions>. Attention is drawn to the limitation of liability, indemnification and jurisdiction issues defined therein. Any holder of this document is advised that information contained hereon reflects the Company's findings at the time of its intervention only and within the limits of Client's instructions, if any. The Company's sole responsibility is to its Client and this document does not exonerate parties to a transaction from exercising all their rights and obligations under the transaction documents. This document cannot be reproduced except in full, without prior written approval of the Company. Any unauthorized alteration, forgery or falsification of the content or appearance of this document is unlawful and offenders may be prosecuted to the fullest extent of the law. Unless otherwise stated the results shown in this test report refer only to the sample(s) tested and such sample(s) are retained for 30 days only.

Attention: To check the authenticity of testing /inspection report & certificate, please contact us at telephone: (86-755) 8307 1443, or email: CN.Doccheck@sgs.com
 No.1 Workshop, M-10, Middle Section, Science & Technology Park, Nanshan District, Shenzhen, Guangdong, China 518057 t (86-755) 26012053 f (86-755) 26710594 www.sgs.com.cn
 中国·广东·深圳市南山区科技园中区M-10栋1号厂房 邮编: 518057 t (86-755) 26012053 f (86-755) 26710594 sgs.china@sgs.com

11ac_VHT(80M)_TX_CH_122_Horizontal-Peak

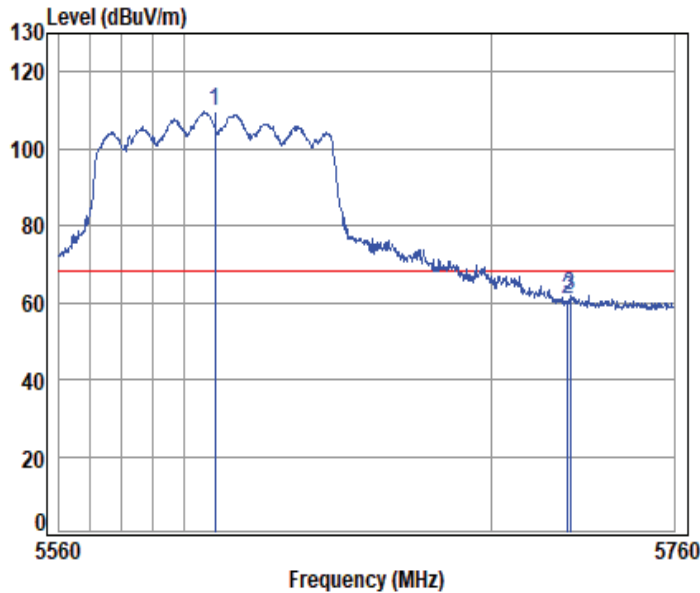

Condition: 3m HORIZONTAL

Job No : 01607WM

Mode : 5610 Band edge

: 5G Wi-Fi 11ac80

	Cable	Ant	Preamp	Read	Limit	Over			
Freq	Loss	Factor	Factor	Level	Level	Line	Limit	Remark	
MHz	dB	dB/m	dB	dBuV	dBuV/m	dBuV/m	dB		
1 pp 5610.000	10.43	33.02	30.69	96.82	109.58	68.20	41.38	peak	
2 5725.000	10.68	33.25	30.72	47.80	61.01	68.20	-7.19	peak	
3 5725.702	10.68	33.25	30.72	48.70	61.91	68.20	-6.29	peak	



11ac_VHT(80M)_TX_CH_122_Vertical-Peak

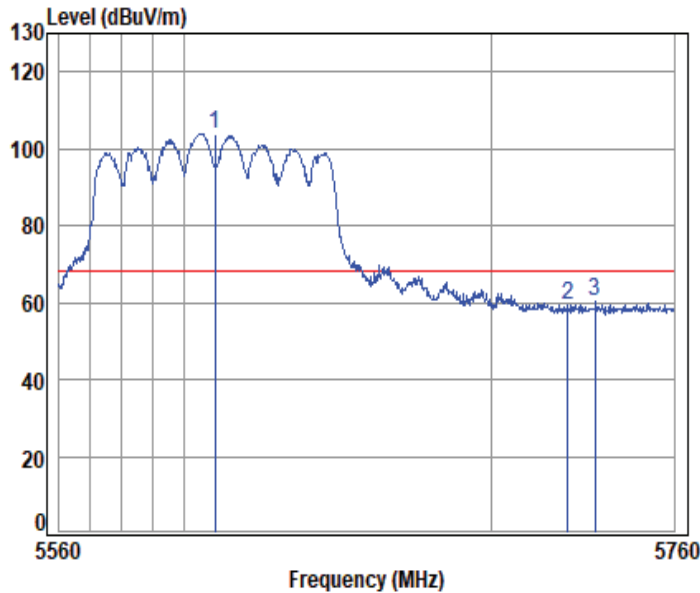

Condition: 3m VERTICAL

Job No : 01607WM

Mode : 5610 Band edge

: 5G Wi-Fi 11ac80

	Cable	Ant	Preamp	Read	Limit	Over			
Freq	Loss	Factor	Factor	Level	Level	Line	Limit	Remark	
MHz	dB	dB/m	dB	dBuV	dBuV/m	dBuV/m	dB		
1 pp 5610.000	10.43	33.02	30.69	91.19	103.95	68.20	35.75	peak	
2 5725.000	10.68	33.25	30.72	46.21	59.42	68.20	-8.78	peak	
3 5734.004	10.72	33.27	30.73	46.87	60.13	68.20	-8.07	peak	



Unless otherwise agreed in writing, this document is issued by the Company subject to its General Conditions of Service printed overleaf, available on request or accessible at <https://www.sgs.com/en/Terms-and-Conditions>. Attention is drawn to the limitation of liability, indemnification and jurisdiction issues defined therein. Any holder of this document is advised that information contained hereon reflects the Company's findings at the time of its intervention only and within the limits of Client's instructions, if any. The Company's sole responsibility is to its Client and this document does not exonerate parties to a transaction from exercising all their rights and obligations under the transaction documents. This document cannot be reproduced except in full, without prior written approval of the Company. Any unauthorized alteration, forgery or falsification of the content or appearance of this document is unlawful and offenders may be prosecuted to the fullest extent of the law. Unless otherwise stated the results shown in this test report refer only to the sample(s) tested and such sample(s) are retained for 30 days only.

Attention: To check the authenticity of testing /inspection report & certificate, please contact us at telephone: (86-755) 8307 1443, or email: CN.Doccheck@sgs.com
 No.1 Workshop, M-10, Middle Section, Science & Technology Park, Nanshan District, Shenzhen, Guangdong, China 518057 t (86-755) 26012053 f (86-755) 26710594 www.sgs.com.cn
 中国·广东·深圳市南山区科技园中区M-10栋1号厂房 邮编: 518057 t (86-755) 26012053 f (86-755) 26710594 sgs.china@sgs.com

11ac_VHT(160M)_TX_CH_114_Horizontal-Peak

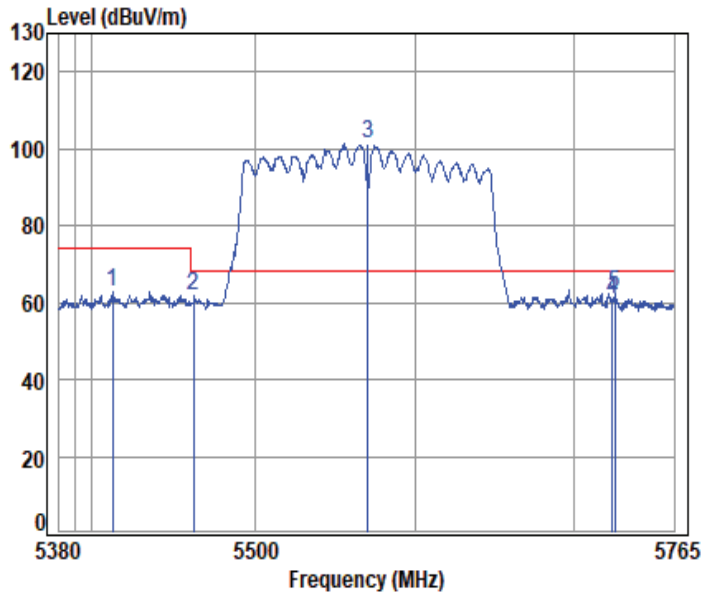

Condition: 3m HORIZONTAL

Job No : 01607WM

Mode : 5570 Band edge

: 5G Wi-Fi 11ac160

	Cable	Ant	Preamp	Read	Limit	Over			
Freq	Loss	Factor	Factor	Level	Level	Line	Limit	Remark	
MHz	dB	dB/m	dB	dBuV	dBuV/m	dBuV/m	dB		
1	5412.448	10.62	32.82	30.63	50.01	62.82	74.00	-11.18 peak	
2	5462.054	10.60	32.90	30.65	48.75	61.60	68.20	-6.60 peak	
3 pp	5570.000	10.46	32.94	30.68	88.57	101.29	68.20	33.09 peak	
4	5725.000	10.68	33.25	30.72	47.71	60.92	68.20	-7.28 peak	
5	5726.875	10.68	33.25	30.72	48.94	62.15	68.20	-6.05 peak	



Unless otherwise agreed in writing, this document is issued by the Company subject to its General Conditions of Service printed overleaf, available on request or accessible at <https://www.sgs.com/en/Terms-and-Conditions>. Attention is drawn to the limitation of liability, indemnification and jurisdiction issues defined therein. Any holder of this document is advised that information contained hereon reflects the Company's findings at the time of its intervention only and within the limits of Client's instructions, if any. The Company's sole responsibility is to its Client and this document does not exonerate parties to a transaction from exercising all their rights and obligations under the transaction documents. This document cannot be reproduced except in full, without prior written approval of the Company. Any unauthorized alteration, forgery or falsification of the content or appearance of this document is unlawful and offenders may be prosecuted to the fullest extent of the law. Unless otherwise stated the results shown in this test report refer only to the sample(s) tested and such sample(s) are retained for 30 days only.

Attention: To check the authenticity of testing /inspection report & certificate, please contact us at telephone: (86-755) 8307 1443, or email: CN.Doccheck@sgs.com
 No.1 Workshop, M-10, Middle Section, Science & Technology Park, Nanshan District, Shenzhen, Guangdong, China 518057 t (86-755) 26012053 f (86-755) 26710594 www.sgs.com.cn
 中国·广东·深圳市南山区科技园中区M-10栋1号厂房 邮编: 518057 t (86-755) 26012053 f (86-755) 26710594 sgs.china@sgs.com

11ac_VHT(160M)_TX_CH_114_Horizontal-Avg

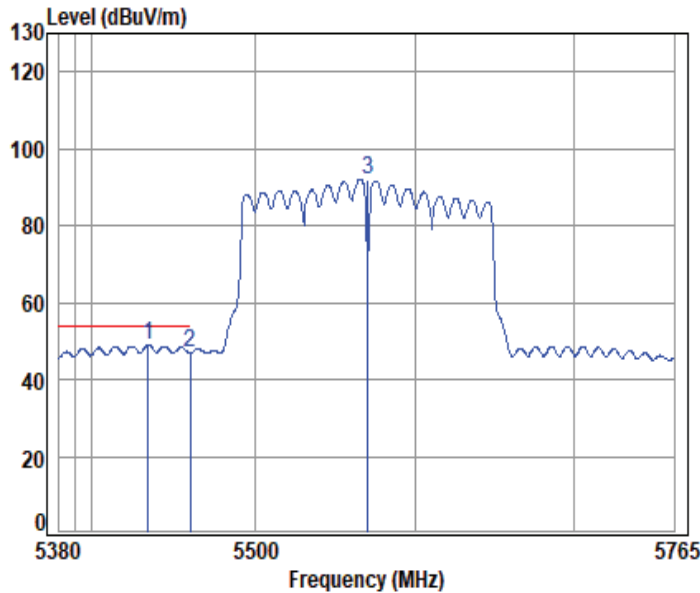

Condition: 3m HORIZONTAL

Job No : 01607WM

Mode : 5570 Band edge

: 5G Wi-Fi 11ac160

	Cable	Ant	Preamp	Read	Limit	Over			
Freq	Loss	Factor	Factor	Level	Level	Line	Limit	Remark	
MHz	dB	dB/m	dB	dBuV	dBuV/m	dBuV/m	dB		
1 pp 5433.813	10.61	32.87	30.64	36.05	48.89	54.00	-5.11	Average	
2 5460.000	10.60	32.90	30.64	34.02	46.88	54.00	-7.12	Average	
3 5570.000	10.46	32.94	30.68	79.34	92.06	-----	-----	Average	



Unless otherwise agreed in writing, this document is issued by the Company subject to its General Conditions of Service printed overleaf, available on request or accessible at <https://www.sgs.com/en/Terms-and-Conditions>. Attention is drawn to the limitation of liability, indemnification and jurisdiction issues defined therein. Any holder of this document is advised that information contained hereon reflects the Company's findings at the time of its intervention only and within the limits of Client's instructions, if any. The Company's sole responsibility is to its Client and this document does not exonerate parties to a transaction from exercising all their rights and obligations under the transaction documents. This document cannot be reproduced except in full, without prior written approval of the Company. Any unauthorized alteration, forgery or falsification of the content or appearance of this document is unlawful and offenders may be prosecuted to the fullest extent of the law. Unless otherwise stated the results shown in this test report refer only to the sample(s) tested and such sample(s) are retained for 30 days only.

Attention: To check the authenticity of testing /inspection report & certificate, please contact us at telephone: (86-755) 8307 1443, or email: CN.Doccheck@sgs.com
 No.1 Workshop, M-10, Middle Section, Science & Technology Park, Nanshan District, Shenzhen, Guangdong, China 518057 t (86-755) 26012053 f (86-755) 26710594 www.sgs.com.cn
 中国·广东·深圳市南山区科技园中区M-10栋1号厂房 邮编: 518057 t (86-755) 26012053 f (86-755) 26710594 sgs.china@sgs.com

11ac_VHT(160M)_TX_CH_114_Vertical-Peak

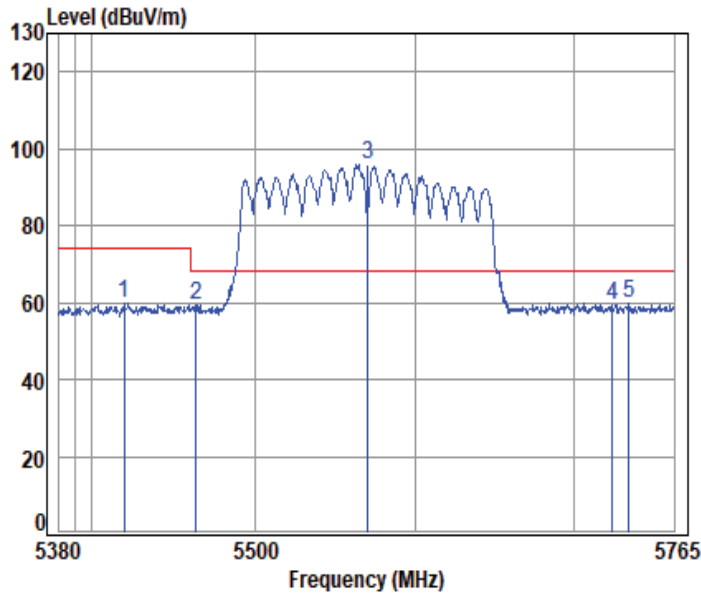

Condition: 3m VERTICAL

Job No : 01607WM

Mode : 5570 Band edge

: 5G Wi-Fi 11ac160

	Cable Freq	Ant Loss	Preamp	Read Level	Limit Level	Over Limit	Remark
	MHz	dB	dB/m	dB	dBuV	dBuV/m	dBuV/m
1	5419.186	10.61	32.84	30.63	47.21	60.03	74.00 -13.97 peak
2	5463.564	10.59	32.90	30.65	46.52	59.36	68.20 -8.84 peak
3 pp	5570.000	10.46	32.94	30.68	83.01	95.73	68.20 27.53 peak
4	5725.000	10.68	33.25	30.72	46.30	59.51	68.20 -8.69 peak
5	5735.986	10.73	33.27	30.73	46.56	59.83	68.20 -8.37 peak



Unless otherwise agreed in writing, this document is issued by the Company subject to its General Conditions of Service printed overleaf, available on request or accessible at <https://www.sgs.com/en/Terms-and-Conditions>. Attention is drawn to the limitation of liability, indemnification and jurisdiction issues defined therein. Any holder of this document is advised that information contained hereon reflects the Company's findings at the time of its intervention only and within the limits of Client's instructions, if any. The Company's sole responsibility is to its Client and this document does not exonerate parties to a transaction from exercising all their rights and obligations under the transaction documents. This document cannot be reproduced except in full, without prior written approval of the Company. Any unauthorized alteration, forgery or falsification of the content or appearance of this document is unlawful and offenders may be prosecuted to the fullest extent of the law. Unless otherwise stated the results shown in this test report refer only to the sample(s) tested and such sample(s) are retained for 30 days only.

Attention: To check the authenticity of testing /inspection report & certificate, please contact us at telephone: (86-755) 8307 1443, or email: CN.Doccheck@sgs.com
 No.1 Workshop, M-10, Middle Section, Science & Technology Park, Nanshan District, Shenzhen, Guangdong, China 518057 t (86-755) 26012053 f (86-755) 26710594 www.sgs.com.cn
 中国·广东·深圳市南山区科技园中区M-10栋1号厂房 邮编: 518057 t (86-755) 26012053 f (86-755) 26710594 sgs.china@sgs.com

11ac_VHT(160M)_TX_CH_114_Vertical-Avg

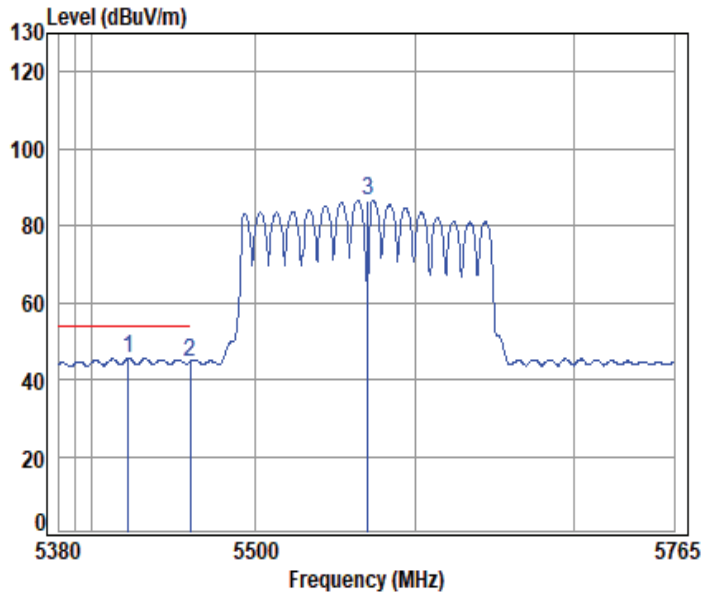

Condition: 3m VERTICAL

Job No : 01607WM

Mode : 5570 Band edge

: 5G Wi-Fi 11ac160

	Cable	Ant	Preamp	Read	Limit	Over			
Freq	Loss	Factor	Factor	Level	Level	Line	Limit	Remark	
MHz	dB	dB/m	dB	dBuV	dBuV/m	dBuV/m	dB		
1 pp 5422.184	10.61	32.84	30.63	32.61	45.43	54.00	-8.57	Average	
2 5460.000	10.60	32.90	30.64	31.79	44.65	54.00	-9.35	Average	
3 5570.000	10.46	32.94	30.68	73.71	86.43	-----	-----	Average	



Unless otherwise agreed in writing, this document is issued by the Company subject to its General Conditions of Service printed overleaf, available on request or accessible at <https://www.sgs.com/en/Terms-and-Conditions>. Attention is drawn to the limitation of liability, indemnification and jurisdiction issues defined therein. Any holder of this document is advised that information contained hereon reflects the Company's findings at the time of its intervention only and within the limits of Client's instructions, if any. The Company's sole responsibility is to its Client and this document does not exonerate parties to a transaction from exercising all their rights and obligations under the transaction documents. This document cannot be reproduced except in full, without prior written approval of the Company. Any unauthorized alteration, forgery or falsification of the content or appearance of this document is unlawful and offenders may be prosecuted to the fullest extent of the law. Unless otherwise stated the results shown in this test report refer only to the sample(s) tested and such sample(s) are retained for 30 days only.

Attention: To check the authenticity of testing /inspection report & certificate, please contact us at telephone: (86-755) 8307 1443, or email: CN.Doccheck@sgs.com
 No.1 Workshop, M-10, Middle Section, Science & Technology Park, Nanshan District, Shenzhen, Guangdong, China 518057 t (86-755) 26012053 f (86-755) 26710594 www.sgs.com.cn
 中国·广东·深圳市南山区科技园中区M-10栋1号厂房 邮编: 518057 t (86-755) 26012053 f (86-755) 26710594 sgs.china@sgs.com

11ax_20M_TX_CH_100_Horizontal-Peak

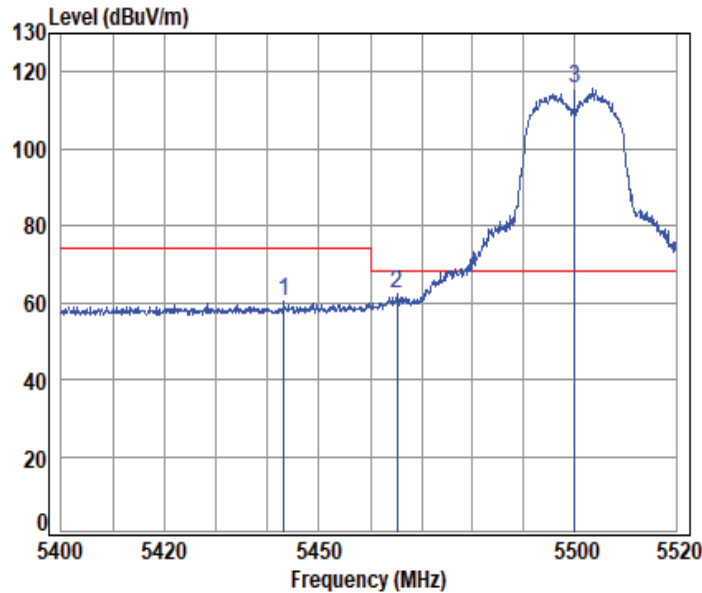

Condition: 3m HORIZONTAL

Job No : 01607WM

Mode : 5500 Band edge

: 5G Wi-Fi 11ax20

	Cable	Ant	Preamp	Read	Limit	Over			
Freq	Loss	Factor	Factor	Level	Level	Line	Limit	Remark	
MHz	dB	dB/m	dB	dBuV	dBuV/m	dBuV/m	dB		
1	5443.136	10.60	32.89	30.64	47.28	60.13	74.00	-13.87	peak
2	5465.313	10.59	32.90	30.65	49.41	62.25	68.20	-5.95	peak
3	pp 5500.000	10.58	32.90	30.66	102.66	115.48	68.20	47.28	peak



Unless otherwise agreed in writing, this document is issued by the Company subject to its General Conditions of Service printed overleaf, available on request or accessible at <https://www.sgs.com/en/Terms-and-Conditions>. Attention is drawn to the limitation of liability, indemnification and jurisdiction issues defined therein. Any holder of this document is advised that information contained hereon reflects the Company's findings at the time of its intervention only and within the limits of Client's instructions, if any. The Company's sole responsibility is to its Client and this document does not exonerate parties to a transaction from exercising all their rights and obligations under the transaction documents. This document cannot be reproduced except in full, without prior written approval of the Company. Any unauthorized alteration, forgery or falsification of the content or appearance of this document is unlawful and offenders may be prosecuted to the fullest extent of the law. Unless otherwise stated the results shown in this test report refer only to the sample(s) tested and such sample(s) are retained for 30 days only.

Attention: To check the authenticity of testing /inspection report & certificate, please contact us at telephone: (86-755) 8307 1443, or email: CN.Doccheck@sgs.com
 No.1 Workshop, M-10, Middle Section, Science & Technology Park, Nanshan District, Shenzhen, Guangdong, China 518057 t (86-755) 26012053 f (86-755) 26710594 www.sgs.com.cn
 中国·广东·深圳市南山区科技园中区M-10栋1号厂房 邮编: 518057 t (86-755) 26012053 f (86-755) 26710594 sgs.china@sgs.com

11ax_20M_TX_CH_100_Horizontal-Avg

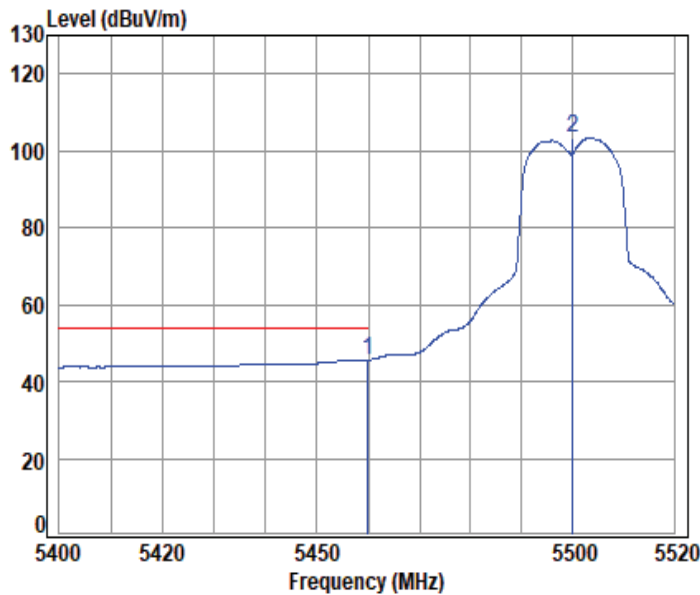

Condition: 3m HORIZONTAL

Job No : 01607WM

Mode : 5500 Band edge

: 5G Wi-Fi 11ax20

	Cable	Ant	Preamp	Read	Limit	Over			
Freq	Loss	Factor	Factor	Level	Level	Line	Limit	Remark	
MHz	dB	dB/m	dB	dBuV	dBuV/m	dBuV/m	dB		
1 pp 5459.910	10.60	32.90	30.64	32.61	45.47	54.00	-8.53	Average	
2 5500.000	10.58	32.90	30.66	90.45	103.27	-----	-----	Average	



Unless otherwise agreed in writing, this document is issued by the Company subject to its General Conditions of Service printed overleaf, available on request or accessible at <https://www.sgs.com/en/Terms-and-Conditions>. Attention is drawn to the limitation of liability, indemnification and jurisdiction issues defined therein. Any holder of this document is advised that information contained hereon reflects the Company's findings at the time of its intervention only and within the limits of Client's instructions, if any. The Company's sole responsibility is to its Client and this document does not exonerate parties to a transaction from exercising all their rights and obligations under the transaction documents. This document cannot be reproduced except in full, without prior written approval of the Company. Any unauthorized alteration, forgery or falsification of the content or appearance of this document is unlawful and offenders may be prosecuted to the fullest extent of the law. Unless otherwise stated the results shown in this test report refer only to the sample(s) tested and such sample(s) are retained for 30 days only.

Attention: To check the authenticity of testing /inspection report & certificate, please contact us at telephone: (86-755) 8307 1443, or email: CN.Doccheck@sgs.com
 No.1 Workshop, M-10, Middle Section, Science & Technology Park, Nanshan District, Shenzhen, Guangdong, China 518057 t (86-755) 26012053 f (86-755) 26710594 www.sgs.com.cn
 中国·广东·深圳市南山区科技园中区M-10栋1号厂房 邮编: 518057 t (86-755) 26012053 f (86-755) 26710594 sgs.china@sgs.com

11ax_20M_TX_CH_100_Vertical-Peak

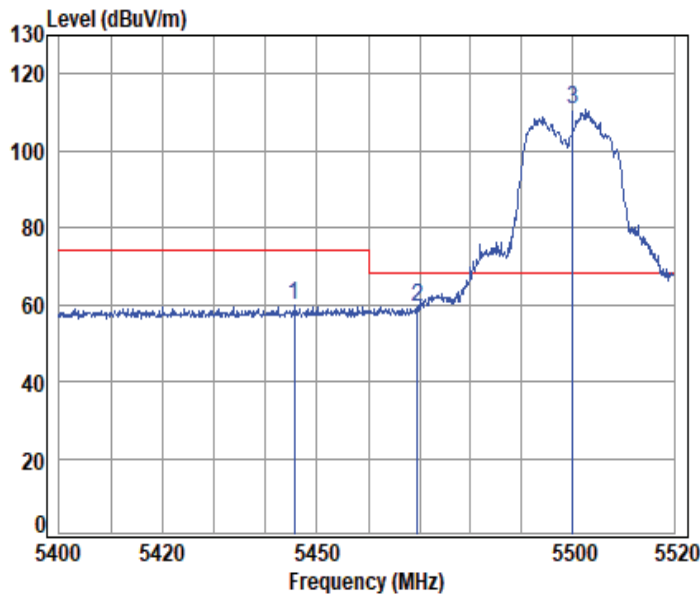

Condition: 3m VERTICAL

Job No : 01607WM

Mode : 5500 Band edge

: 5G Wi-Fi 11ax20

	Cable	Ant	Preamp	Read	Limit	Over		
Freq	Loss	Factor	Factor	Level	Level	Line	Limit	Remark
MHz	dB	dB/m	dB	dBuV	dBuV/m	dBuV/m	dB	
1	5445.529	10.60	32.89	30.64	47.19	60.04	74.00	-13.96 peak
2	5469.639	10.59	32.90	30.65	46.32	59.16	68.20	-9.04 peak
3	pp 5500.000	10.58	32.90	30.66	97.71	110.53	68.20	42.33 peak



Unless otherwise agreed in writing, this document is issued by the Company subject to its General Conditions of Service printed overleaf, available on request or accessible at <https://www.sgs.com/en/Terms-and-Conditions>. Attention is drawn to the limitation of liability, indemnification and jurisdiction issues defined therein. Any holder of this document is advised that information contained hereon reflects the Company's findings at the time of its intervention only and within the limits of Client's instructions, if any. The Company's sole responsibility is to its Client and this document does not exonerate parties to a transaction from exercising all their rights and obligations under the transaction documents. This document cannot be reproduced except in full, without prior written approval of the Company. Any unauthorized alteration, forgery or falsification of the content or appearance of this document is unlawful and offenders may be prosecuted to the fullest extent of the law. Unless otherwise stated the results shown in this test report refer only to the sample(s) tested and such sample(s) are retained for 30 days only.

Attention: To check the authenticity of testing /inspection report & certificate, please contact us at telephone: (86-755) 8307 1443, or email: CN.Doccheck@sgs.com
 No.1 Workshop, M-10, Middle Section, Science & Technology Park, Nanshan District, Shenzhen, Guangdong, China 518057 t (86-755) 26012053 f (86-755) 26710594 www.sgs.com.cn
 中国·广东·深圳市南山区科技园中区M-10栋1号厂房 邮编: 518057 t (86-755) 26012053 f (86-755) 26710594 sgs.china@sgs.com

11ax_20M_TX_CH_100_Vertical-Avg

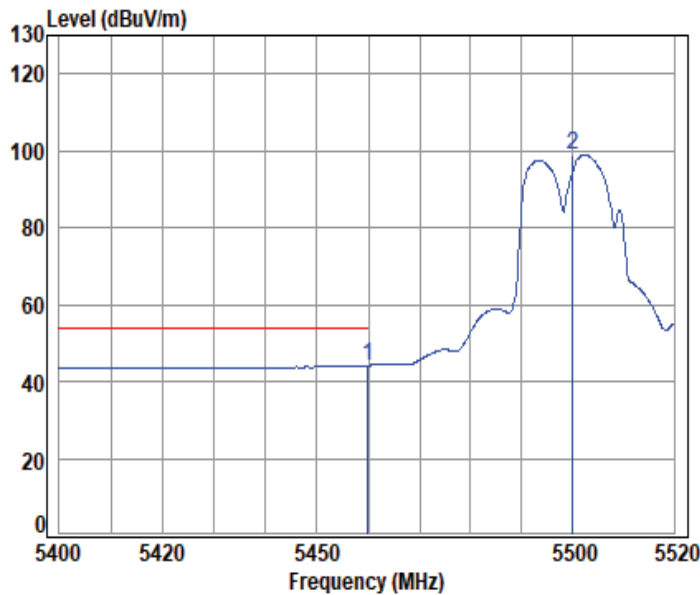

Condition: 3m VERTICAL

Job No : 01607WM

Mode : 5500 Band edge

: 5G Wi-Fi 11ax20

	Cable	Ant	Preamp	Read	Limit	Over			
Freq	Loss	Factor	Factor	Level	Level	Line	Limit	Remark	
MHz	dB	dB/m	dB	dBuV	dBuV/m	dBuV/m	dB		
1 pp 5459.910	10.60	32.90	30.64	31.25	44.11	54.00	-9.89	Average	
2 5500.000	10.58	32.90	30.66	86.13	98.95	-----	-----	Average	



Unless otherwise agreed in writing, this document is issued by the Company subject to its General Conditions of Service printed overleaf, available on request or accessible at <https://www.sgs.com/en/Terms-and-Conditions>. Attention is drawn to the limitation of liability, indemnification and jurisdiction issues defined therein. Any holder of this document is advised that information contained hereon reflects the Company's findings at the time of its intervention only and within the limits of Client's instructions, if any. The Company's sole responsibility is to its Client and this document does not exonerate parties to a transaction from exercising all their rights and obligations under the transaction documents. This document cannot be reproduced except in full, without prior written approval of the Company. Any unauthorized alteration, forgery or falsification of the content or appearance of this document is unlawful and offenders may be prosecuted to the fullest extent of the law. Unless otherwise stated the results shown in this test report refer only to the sample(s) tested and such sample(s) are retained for 30 days only.

Attention: To check the authenticity of testing /inspection report & certificate, please contact us at telephone: (86-755) 8307 1443, or email: CN.Doccheck@sgs.com
 No.1 Workshop, M-10, Middle Section, Science & Technology Park, Nanshan District, Shenzhen, Guangdong, China 518057 t (86-755) 26012053 f (86-755) 26710594 www.sgs.com.cn
 中国·广东·深圳市南山区科技园中区M-10栋1号厂房 邮编: 518057 t (86-755) 26012053 f (86-755) 26710594 sgs.china@sgs.com

11ax_20M_TX_CH_140_Horizontal-Peak

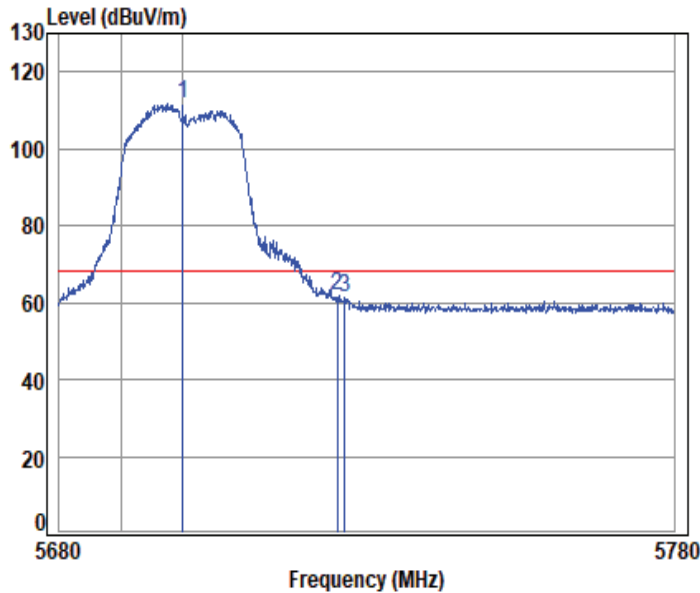

Condition: 3m HORIZONTAL

Job No : 01607WM

Mode : 5700 Band edge

: 5G Wi-Fi 11ax20

	Cable	Ant	Preamp	Read	Limit	Over		
Freq	Loss	Factor	Factor	Level	Level	Line	Limit	Remark
MHz	dB	dB/m	dB	dBuV	dBuV/m	dBuV/m	dB	
1 pp 5700.000	10.56	33.20	30.72	98.82	111.86	68.20	43.66	peak
2 5725.000	10.68	33.25	30.72	48.75	61.96	68.20	-6.24	peak
3 5726.283	10.68	33.25	30.72	48.03	61.24	68.20	-6.96	peak



Unless otherwise agreed in writing, this document is issued by the Company subject to its General Conditions of Service printed overleaf, available on request or accessible at <https://www.sgs.com/en/Terms-and-Conditions>. Attention is drawn to the limitation of liability, indemnification and jurisdiction issues defined therein. Any holder of this document is advised that information contained hereon reflects the Company's findings at the time of its intervention only and within the limits of Client's instructions, if any. The Company's sole responsibility is to its Client and this document does not exonerate parties to a transaction from exercising all their rights and obligations under the transaction documents. This document cannot be reproduced except in full, without prior written approval of the Company. Any unauthorized alteration, forgery or falsification of the content or appearance of this document is unlawful and offenders may be prosecuted to the fullest extent of the law. Unless otherwise stated the results shown in this test report refer only to the sample(s) tested and such sample(s) are retained for 30 days only.

Attention: To check the authenticity of testing /inspection report & certificate, please contact us at telephone: (86-755) 8307 1443, or email: CN.Doccheck@sgs.com
 No.1 Workshop, M-10, Middle Section, Science & Technology Park, Nanshan District, Shenzhen, Guangdong, China 518057 t (86-755) 26012053 f (86-755) 26710594 www.sgs.com.cn
 中国·广东·深圳市南山区科技园中区M-10栋1号厂房 邮编: 518057 t (86-755) 26012053 f (86-755) 26710594 sgs.china@sgs.com

11ax_20M_TX_CH_140_Vertical-Peak

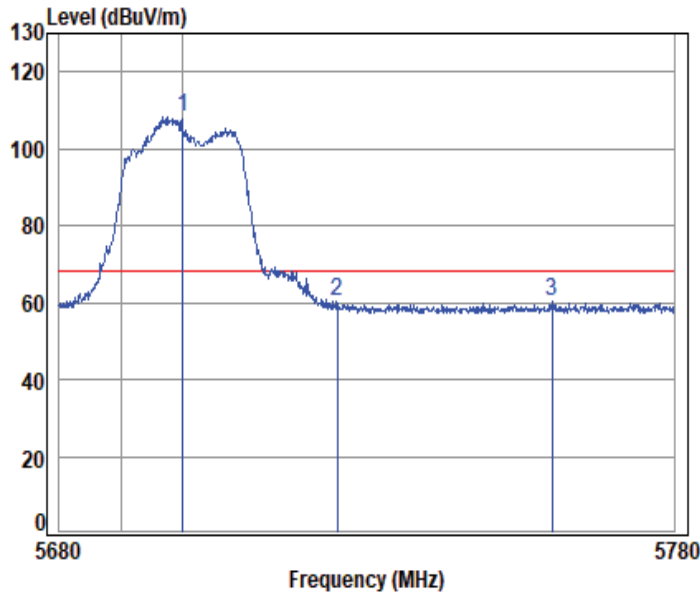

Condition: 3m VERTICAL

Job No : 01607WM

Mode : 5700 Band edge

: 5G Wi-Fi 11ax20

	Cable	Ant	Preamp	Read	Limit	Over			
Freq	Loss	Factor	Factor	Level	Level	Line	Limit	Remark	
MHz	dB	dB/m	dB	dBuV	dBuV/m	dBuV/m	dB		
1 pp 5700.000	10.56	33.20	30.72	95.10	108.14	68.20	39.94	peak	
2 5725.000	10.68	33.25	30.72	47.09	60.30	68.20	-7.90	peak	
3 5760.061	10.84	33.32	30.73	46.84	60.27	68.20	-7.93	peak	



Unless otherwise agreed in writing, this document is issued by the Company subject to its General Conditions of Service printed overleaf, available on request or accessible at <https://www.sgs.com/en/Terms-and-Conditions>. Attention is drawn to the limitation of liability, indemnification and jurisdiction issues defined therein. Any holder of this document is advised that information contained hereon reflects the Company's findings at the time of its intervention only and within the limits of Client's instructions, if any. The Company's sole responsibility is to its Client and this document does not exonerate parties to a transaction from exercising all their rights and obligations under the transaction documents. This document cannot be reproduced except in full, without prior written approval of the Company. Any unauthorized alteration, forgery or falsification of the content or appearance of this document is unlawful and offenders may be prosecuted to the fullest extent of the law. Unless otherwise stated the results shown in this test report refer only to the sample(s) tested and such sample(s) are retained for 30 days only.

Attention: To check the authenticity of testing /inspection report & certificate, please contact us at telephone: (86-755) 8307 1443, or email: CN.Doccheck@sgs.com
 No.1 Workshop, M-10, Middle Section, Science & Technology Park, Nanshan District, Shenzhen, Guangdong, China 518057 t (86-755) 26012053 f (86-755) 26710594 www.sgs.com.cn
 中国·广东·深圳市南山区科技园中区M-10栋1号厂房 邮编: 518057 t (86-755) 26012053 f (86-755) 26710594 sgs.china@sgs.com

11ax_40M_TX_CH_3.45_Horizontal-Peak

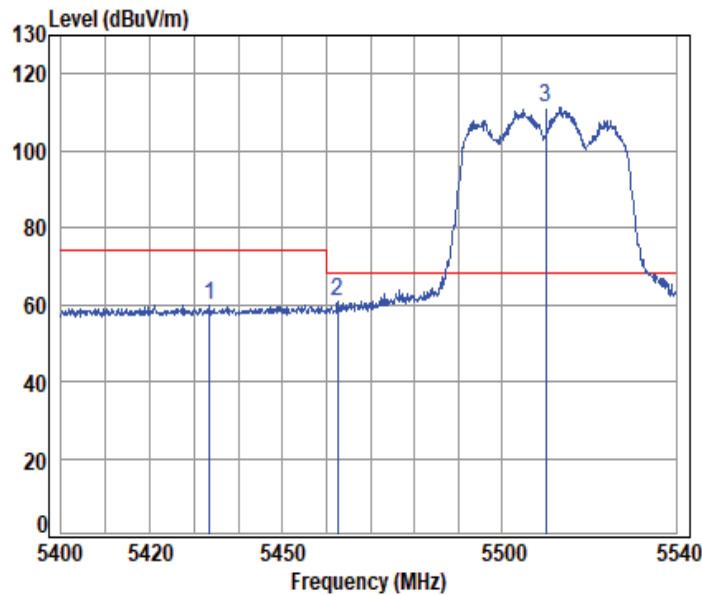

Condition: 3m HORIZONTAL

Job No : 01607WM

Mode : 5510 Band edge

: 5G Wi-Fi 11ax40

	Cable	Ant	Preamp	Read	Limit	Over		
Freq	Loss	Factor	Factor	Level	Level	Line	Limit	Remark
MHz	dB	dB/m	dB	dBuV	dBuV/m	dBuV/m	dB	
1	5433.552	10.61	32.87	30.64	47.14	59.98	74.00	-14.02 peak
2	5462.417	10.60	32.90	30.65	47.94	60.79	68.20	-7.41 peak
3	pp 5510.000	10.56	32.90	30.66	98.30	111.10	68.20	42.90 peak



Unless otherwise agreed in writing, this document is issued by the Company subject to its General Conditions of Service printed overleaf, available on request or accessible at <https://www.sgs.com/en/Terms-and-Conditions>. Attention is drawn to the limitation of liability, indemnification and jurisdiction issues defined therein. Any holder of this document is advised that information contained hereon reflects the Company's findings at the time of its intervention only and within the limits of Client's instructions, if any. The Company's sole responsibility is to its Client and this document does not exonerate parties to a transaction from exercising all their rights and obligations under the transaction documents. This document cannot be reproduced except in full, without prior written approval of the Company. Any unauthorized alteration, forgery or falsification of the content or appearance of this document is unlawful and offenders may be prosecuted to the fullest extent of the law. Unless otherwise stated the results shown in this test report refer only to the sample(s) tested and such sample(s) are retained for 30 days only.

Attention: To check the authenticity of testing /inspection report & certificate, please contact us at telephone: (86-755) 8307 1443, or email: CN.Doccheck@sgs.com
 No.1 Workshop, M-10, Middle Section, Science & Technology Park, Nanshan District, Shenzhen, Guangdong, China 518057 t (86-755) 26012053 f (86-755) 26710594 www.sgs.com.cn
 中国·广东·深圳市南山区科技园中区M-10栋1号厂房 邮编: 518057 t (86-755) 26012053 f (86-755) 26710594 sgs.china@sgs.com

11ax_40M_TX_CH_3.45_Horizontal-Avg

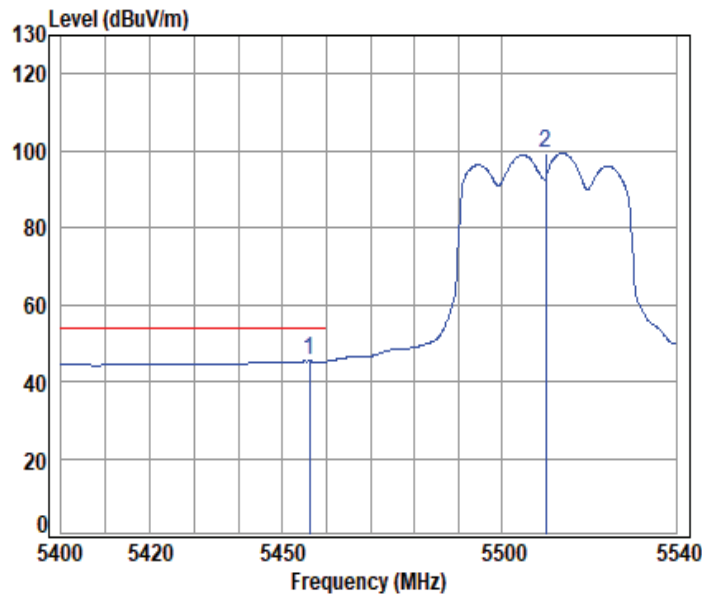

Condition: 3m HORIZONTAL

Job No : 01607WM

Mode : 5510 Band edge

: 5G Wi-Fi 11ax40

	Cable	Ant	Preamp	Read	Limit	Over			
Freq	Loss	Factor	Factor	Level	Level	Line	Limit	Remark	
MHz	dB	dB/m	dB	dBuV	dBuV/m	dBuV/m	dB		
1 pp 5456.129	10.60	32.90	30.64	32.38	45.24	54.00	-8.76	Average	
2 5510.000	10.56	32.90	30.66	86.47	99.27	-----	-----	Average	



Unless otherwise agreed in writing, this document is issued by the Company subject to its General Conditions of Service printed overleaf, available on request or accessible at <https://www.sgs.com/en/Terms-and-Conditions>. Attention is drawn to the limitation of liability, indemnification and jurisdiction issues defined therein. Any holder of this document is advised that information contained hereon reflects the Company's findings at the time of its intervention only and within the limits of Client's instructions, if any. The Company's sole responsibility is to its Client and this document does not exonerate parties to a transaction from exercising all their rights and obligations under the transaction documents. This document cannot be reproduced except in full, without prior written approval of the Company. Any unauthorized alteration, forgery or falsification of the content or appearance of this document is unlawful and offenders may be prosecuted to the fullest extent of the law. Unless otherwise stated the results shown in this test report refer only to the sample(s) tested and such sample(s) are retained for 30 days only.

Attention: To check the authenticity of testing /inspection report & certificate, please contact us at telephone: (86-755) 8307 1443, or email: CN.Doccheck@sgs.com
 No.1 Workshop, M-10, Middle Section, Science & Technology Park, Nanshan District, Shenzhen, Guangdong, China 518057 t (86-755) 26012053 f (86-755) 26710594 www.sgs.com.cn
 中国·广东·深圳市南山区科技园中区M-10栋1号厂房 邮编: 518057 t (86-755) 26012053 f (86-755) 26710594 sgs.china@sgs.com

11ax_40M_TX_CH_3.45_Verical-Peak

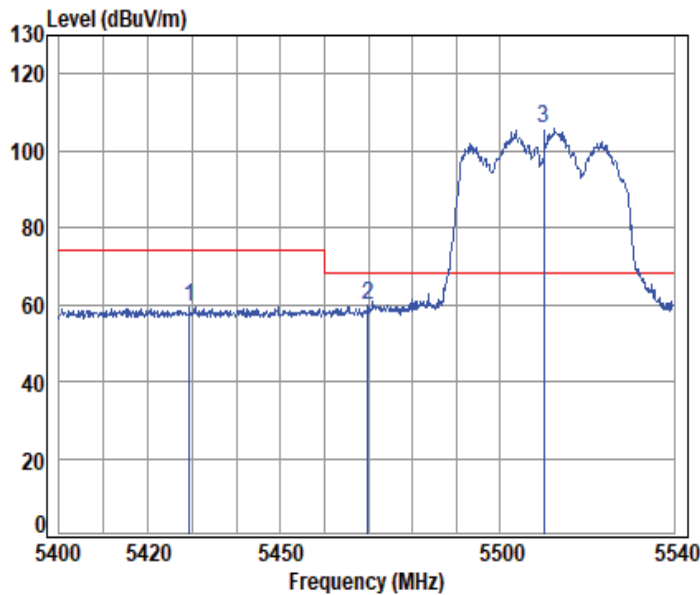

Condition: 3m VERTICAL

Job No : 01607WM

Mode : 5510 Band edge

: 5G Wi-Fi 11ax40

	Cable	Ant	Preamp	Read	Limit	Over			
Freq	Loss	Factor	Factor	Level	Level	Line	Limit	Remark	
MHz	dB	dB/m	dB	dBuV	dBuV/m	dBuV/m	dB		
1	5429.381	10.61	32.86	30.64	46.37	59.20	74.00	-14.80 peak	
2	5469.832	10.59	32.90	30.65	47.00	59.84	68.20	-8.36 peak	
3 pp	5510.000	10.56	32.90	30.66	93.22	106.02	68.20	37.82 peak	



Unless otherwise agreed in writing, this document is issued by the Company subject to its General Conditions of Service printed overleaf, available on request or accessible at <https://www.sgs.com/en/Terms-and-Conditions>. Attention is drawn to the limitation of liability, indemnification and jurisdiction issues defined therein. Any holder of this document is advised that information contained hereon reflects the Company's findings at the time of its intervention only and within the limits of Client's instructions, if any. The Company's sole responsibility is to its Client and this document does not exonerate parties to a transaction from exercising all their rights and obligations under the transaction documents. This document cannot be reproduced except in full, without prior written approval of the Company. Any unauthorized alteration, forgery or falsification of the content or appearance of this document is unlawful and offenders may be prosecuted to the fullest extent of the law. Unless otherwise stated the results shown in this test report refer only to the sample(s) tested and such sample(s) are retained for 30 days only.

Attention: To check the authenticity of testing /inspection report & certificate, please contact us at telephone: (86-755) 8307 1443, or email: CN.Doccheck@sgs.com
 No.1 Workshop, M-10, Middle Section, Science & Technology Park, Nanshan District, Shenzhen, Guangdong, China 518057 t (86-755) 26012053 f (86-755) 26710594 www.sgs.com.cn
 中国·广东·深圳市南山区科技园中区M-10栋1号厂房 邮编: 518057 t (86-755) 26012053 f (86-755) 26710594 sgs.china@sgs.com

11ax_40M_TX_CH_3.45_Vertical-Avg

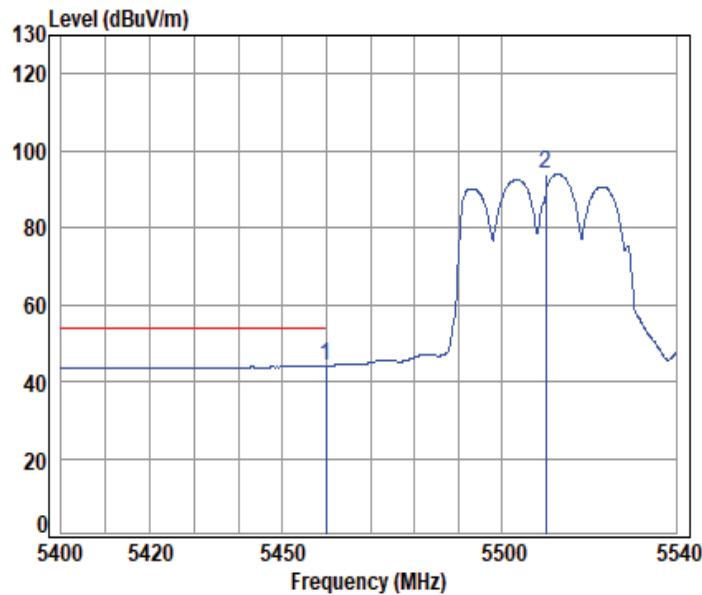

Condition: 3m VERTICAL

Job No : 01607WM

Mode : 5510 Band edge

: 5G Wi-Fi 11ax40

	Cable	Ant	Preamp	Read	Limit	Over			
Freq	Loss	Factor	Factor	Level	Level	Line	Limit	Remark	
MHz	dB	dB/m	dB	dBuV	dBuV/m	dBuV/m	dB		
1 pp 5459.901	10.60	32.90	30.64	31.14	44.00	54.00	-10.00	Average	
2 5510.000	10.56	32.90	30.66	81.18	93.98	-----	-----	Average	



Unless otherwise agreed in writing, this document is issued by the Company subject to its General Conditions of Service printed overleaf, available on request or accessible at <https://www.sgs.com/en/Terms-and-Conditions>. Attention is drawn to the limitation of liability, indemnification and jurisdiction issues defined therein. Any holder of this document is advised that information contained hereon reflects the Company's findings at the time of its intervention only and within the limits of Client's instructions, if any. The Company's sole responsibility is to its Client and this document does not exonerate parties to a transaction from exercising all their rights and obligations under the transaction documents. This document cannot be reproduced except in full, without prior written approval of the Company. Any unauthorized alteration, forgery or falsification of the content or appearance of this document is unlawful and offenders may be prosecuted to the fullest extent of the law. Unless otherwise stated the results shown in this test report refer only to the sample(s) tested and such sample(s) are retained for 30 days only.

Attention: To check the authenticity of testing /inspection report & certificate, please contact us at telephone: (86-755) 8307 1443, or email: CN.Doccheck@sgs.com
 No.1 Workshop, M-10, Middle Section, Science & Technology Park, Nanshan District, Shenzhen, Guangdong, China 518057 t (86-755) 26012053 f (86-755) 26710594 www.sgs.com.cn
 中国·广东·深圳市南山区科技园中区M-10栋1号厂房 邮编: 518057 t (86-755) 26012053 f (86-755) 26710594 sgs.china@sgs.com

11ax_40M_TX_CH_134_Horizontal-Peak

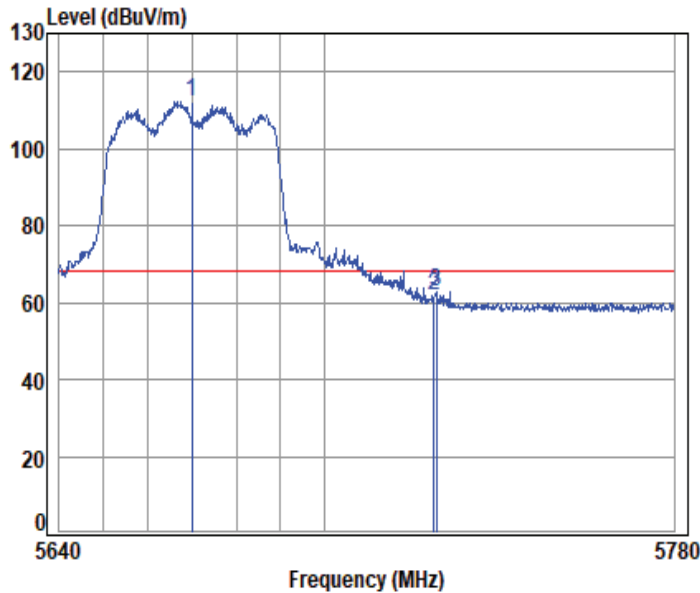

Condition: 3m HORIZONTAL

Job No : 01607WM

Mode : 5670 Band edge

: 5G Wi-Fi 11ax40

	Cable	Ant	Preamp	Read	Limit	Over		
Freq	Loss	Factor	Factor	Level	Level	Line	Limit	Remark
MHz	dB	dB/m	dB	dBuV	dBuV/m	dBuV/m	dB	
1 pp 5670.000	10.52	33.14	30.71	99.50	112.45	68.20	44.25	peak
2 5725.000	10.68	33.25	30.72	48.58	61.79	68.20	-6.41	peak
3 5725.553	10.68	33.25	30.72	49.70	62.91	68.20	-5.29	peak



Unless otherwise agreed in writing, this document is issued by the Company subject to its General Conditions of Service printed overleaf, available on request or accessible at <https://www.sgs.com/en/Terms-and-Conditions>. Attention is drawn to the limitation of liability, indemnification and jurisdiction issues defined therein. Any holder of this document is advised that information contained hereon reflects the Company's findings at the time of its intervention only and within the limits of Client's instructions, if any. The Company's sole responsibility is to its Client and this document does not exonerate parties to a transaction from exercising all their rights and obligations under the transaction documents. This document cannot be reproduced except in full, without prior written approval of the Company. Any unauthorized alteration, forgery or falsification of the content or appearance of this document is unlawful and offenders may be prosecuted to the fullest extent of the law. Unless otherwise stated the results shown in this test report refer only to the sample(s) tested and such sample(s) are retained for 30 days only.

Attention: To check the authenticity of testing /inspection report & certificate, please contact us at telephone: (86-755) 8307 1443, or email: CN.Doccheck@sgs.com
 No.1 Workshop, M-10, Middle Section, Science & Technology Park, Nanshan District, Shenzhen, Guangdong, China 518057 t (86-755) 26012053 f (86-755) 26710594 www.sgs.com.cn
 中国·广东·深圳市南山区科技园中区M-10栋1号厂房 邮编: 518057 t (86-755) 26012053 f (86-755) 26710594 sgs.china@sgs.com

11ax_40M_TX_CH_134_Vertical-Peak

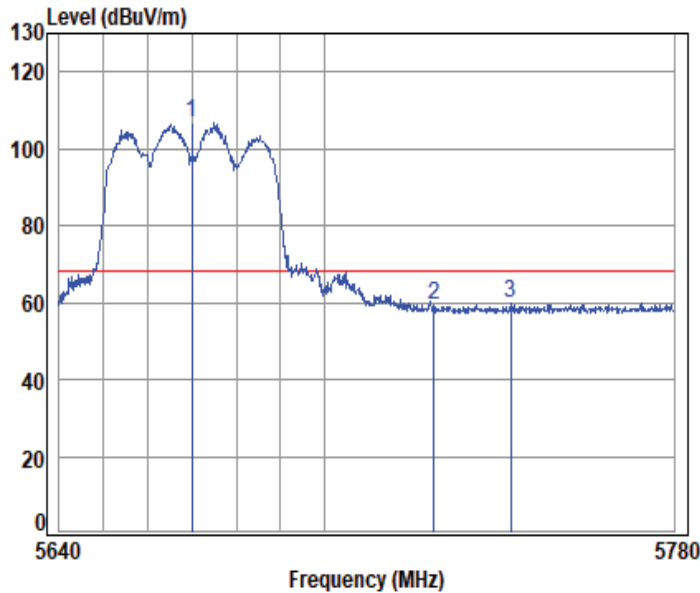

Condition: 3m VERTICAL

Job No : 01607WM

Mode : 5670 Band edge

: 5G Wi-Fi 11ax40

	Cable	Ant	Preamp	Read	Limit	Over		
Freq	Loss	Factor	Factor	Level	Level	Line	Limit	Remark
MHz	dB	dB/m	dB	dBuV	dBuV/m	dBuV/m	dB	
1 pp 5670.000	10.52	33.14	30.71	94.00	106.95	68.20	38.75	peak
2 5725.000	10.68	33.25	30.72	45.92	59.13	68.20	-9.07	peak
3 5742.424	10.76	33.28	30.73	46.43	59.74	68.20	-8.46	peak



Unless otherwise agreed in writing, this document is issued by the Company subject to its General Conditions of Service printed overleaf, available on request or accessible at <https://www.sgs.com/en/Terms-and-Conditions>. Attention is drawn to the limitation of liability, indemnification and jurisdiction issues defined therein. Any holder of this document is advised that information contained hereon reflects the Company's findings at the time of its intervention only and within the limits of Client's instructions, if any. The Company's sole responsibility is to its Client and this document does not exonerate parties to a transaction from exercising all their rights and obligations under the transaction documents. This document cannot be reproduced except in full, without prior written approval of the Company. Any unauthorized alteration, forgery or falsification of the content or appearance of this document is unlawful and offenders may be prosecuted to the fullest extent of the law. Unless otherwise stated the results shown in this test report refer only to the sample(s) tested and such sample(s) are retained for 30 days only.

Attention: To check the authenticity of testing /inspection report & certificate, please contact us at telephone: (86-755) 8307 1443, or email: CN.Doccheck@sgs.com
 No.1 Workshop, M-10, Middle Section, Science & Technology Park, Nanshan District, Shenzhen, Guangdong, China 518057 t (86-755) 26012053 f (86-755) 26710594 www.sgs.com.cn
 中国·广东·深圳市南山区科技园中区M-10栋1号厂房 邮编: 518057 t (86-755) 26012053 f (86-755) 26710594 sgs.china@sgs.com

11ax_80M_TX_CH_106_Horizontal-Peak

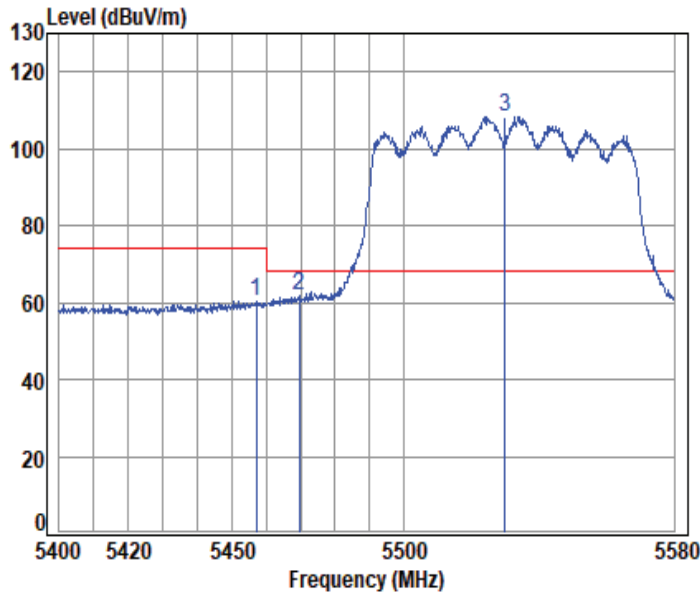

Condition: 3m HORIZONTAL

Job No : 01607WM

Mode : 5530 Band edge

: 5G Wi-Fi 11ax80

	Cable	Ant	Preamp	Read	Limit	Over			
Freq	Loss	Factor	Factor	Level	Level	Line	Limit	Remark	
MHz	dB	dB/m	dB	dBuV	dBuV/m	dBuV/m	dB		
1	5456.959	10.60	32.90	30.64	47.49	60.35	74.00	-13.65 peak	
2	5469.678	10.59	32.90	30.65	48.73	61.57	68.20	-6.63 peak	
3 pp	5530.000	10.53	32.90	30.67	95.49	108.25	68.20	40.05 peak	



Unless otherwise agreed in writing, this document is issued by the Company subject to its General Conditions of Service printed overleaf, available on request or accessible at <https://www.sgs.com/en/Terms-and-Conditions>. Attention is drawn to the limitation of liability, indemnification and jurisdiction issues defined therein. Any holder of this document is advised that information contained hereon reflects the Company's findings at the time of its intervention only and within the limits of Client's instructions, if any. The Company's sole responsibility is to its Client and this document does not exonerate parties to a transaction from exercising all their rights and obligations under the transaction documents. This document cannot be reproduced except in full, without prior written approval of the Company. Any unauthorized alteration, forgery or falsification of the content or appearance of this document is unlawful and offenders may be prosecuted to the fullest extent of the law. Unless otherwise stated the results shown in this test report refer only to the sample(s) tested and such sample(s) are retained for 30 days only.

Attention: To check the authenticity of testing /inspection report & certificate, please contact us at telephone: (86-755) 8307 1443, or email: CN.Doccheck@sgs.com
 No.1 Workshop, M-10, Middle Section, Science & Technology Park, Nanshan District, Shenzhen, Guangdong, China 518057 t (86-755) 26012053 f (86-755) 26710594 www.sgs.com.cn
 中国·广东·深圳市南山区科技园中区M-10栋1号厂房 邮编: 518057 t (86-755) 26012053 f (86-755) 26710594 sgs.china@sgs.com

11ax_80M_TX_CH_106_Horizontal-Avg

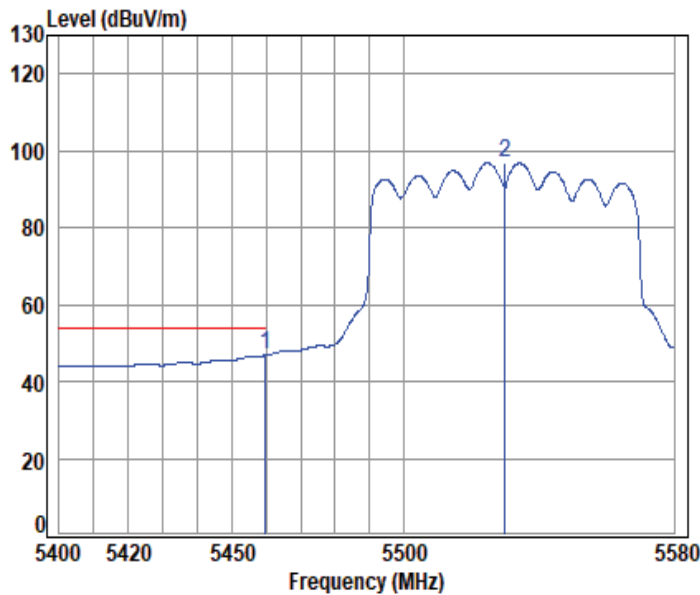

Condition: 3m HORIZONTAL

Job No : 01607WM

Mode : 5530 Band edge

: 5G Wi-Fi 11ax80

	Cable	Ant	Preamp	Read	Limit	Over			
Freq	Loss	Factor	Factor	Level	Level	Line	Limit	Remark	
MHz	dB	dB/m	dB	dBuV	dBuV/m	dBuV/m	dB		
1 pp 5459.823	10.60	32.90	30.64	33.92	46.78	54.00	-7.22	Average	
2 5530.000	10.53	32.90	30.67	83.99	96.75	-----	-----	Average	



Unless otherwise agreed in writing, this document is issued by the Company subject to its General Conditions of Service printed overleaf, available on request or accessible at <https://www.sgs.com/en/Terms-and-Conditions>. Attention is drawn to the limitation of liability, indemnification and jurisdiction issues defined therein. Any holder of this document is advised that information contained hereon reflects the Company's findings at the time of its intervention only and within the limits of Client's instructions, if any. The Company's sole responsibility is to its Client and this document does not exonerate parties to a transaction from exercising all their rights and obligations under the transaction documents. This document cannot be reproduced except in full, without prior written approval of the Company. Any unauthorized alteration, forgery or falsification of the content or appearance of this document is unlawful and offenders may be prosecuted to the fullest extent of the law. Unless otherwise stated the results shown in this test report refer only to the sample(s) tested and such sample(s) are retained for 30 days only.

Attention: To check the authenticity of testing /inspection report & certificate, please contact us at telephone: (86-755) 8307 1443, or email: CN.Doccheck@sgs.com
 No.1 Workshop, M-10, Middle Section, Science & Technology Park, Nanshan District, Shenzhen, Guangdong, China 518057 t (86-755) 26012053 f (86-755) 26710594 www.sgs.com.cn
 中国·广东·深圳市南山区科技园中区M-10栋1号厂房 邮编: 518057 t (86-755) 26012053 f (86-755) 26710594 sgs.china@sgs.com

11ax_80M_TX_CH_106_Verical-Peak

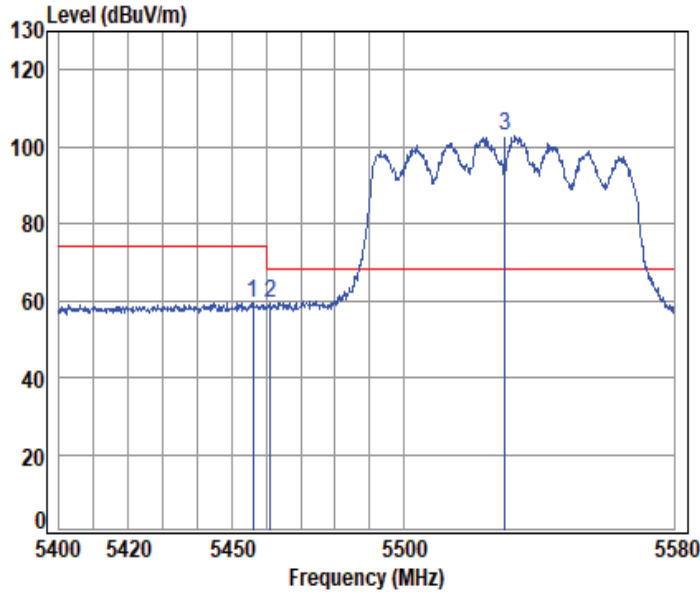

Condition: 3m VERTICAL

Job No : 01607WM

Mode : 5530 Band edge

: 5G Wi-Fi 11ax80

	Cable	Ant	Preamp	Read	Limit	Over			
Freq	Loss	Factor	Factor	Level	Level	Line	Limit	Remark	
MHz	dB	dB/m	dB	dBuV	dBuV/m	dBuV/m	dB		
1	5456.064	10.60	32.90	30.64	46.67	59.53	74.00	-14.47 peak	
2	5461.076	10.60	32.90	30.65	46.61	59.46	68.20	-8.74 peak	
3 pp	5530.000	10.53	32.90	30.67	90.01	102.77	68.20	34.57 peak	



11ax_80M_TX_CH_106_Verical-Avg

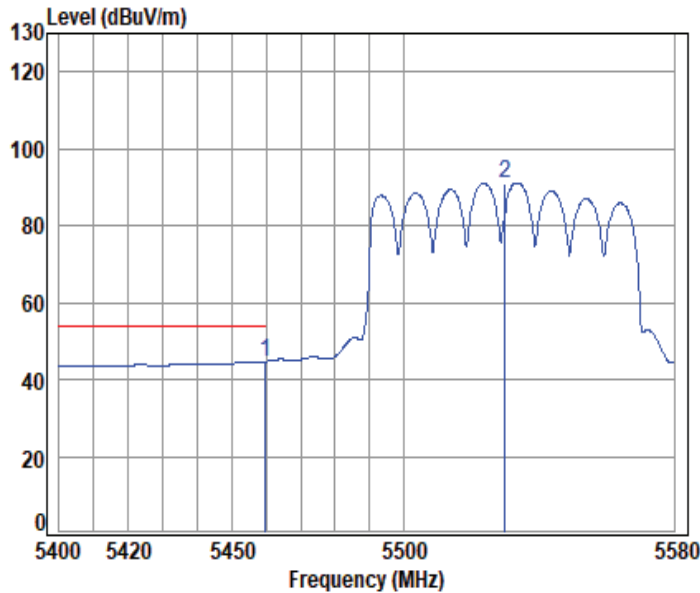

Condition: 3m VERTICAL

Job No : 01607WM

Mode : 5530 Band edge

: 5G Wi-Fi 11ax80

	Cable	Ant	Preamp	Read	Limit	Over			
Freq	Loss	Factor	Factor	Level	Level	Line	Limit	Remark	
MHz	dB	dB/m	dB	dBuV	dBuV/m	dBuV/m	dB		
1 pp 5459.823	10.60	32.90	30.64	31.80	44.66	54.00	-9.34	Average	
2 5530.000	10.53	32.90	30.67	78.37	91.13	-----	-----	Average	



Unless otherwise agreed in writing, this document is issued by the Company subject to its General Conditions of Service printed overleaf, available on request or accessible at <https://www.sgs.com/en/Terms-and-Conditions>. Attention is drawn to the limitation of liability, indemnification and jurisdiction issues defined therein. Any holder of this document is advised that information contained hereon reflects the Company's findings at the time of its intervention only and within the limits of Client's instructions, if any. The Company's sole responsibility is to its Client and this document does not exonerate parties to a transaction from exercising all their rights and obligations under the transaction documents. This document cannot be reproduced except in full, without prior written approval of the Company. Any unauthorized alteration, forgery or falsification of the content or appearance of this document is unlawful and offenders may be prosecuted to the fullest extent of the law. Unless otherwise stated the results shown in this test report refer only to the sample(s) tested and such sample(s) are retained for 30 days only.

Attention: To check the authenticity of testing /inspection report & certificate, please contact us at telephone: (86-755) 8307 1443, or email: CN.Doccheck@sgs.com
 No.1 Workshop, M-10, Middle Section, Science & Technology Park, Nanshan District, Shenzhen, Guangdong, China 518057 t (86-755) 26012053 f (86-755) 26710594 www.sgs.com.cn
 中国·广东·深圳市南山区科技园中区M-10栋1号厂房 邮编: 518057 t (86-755) 26012053 f (86-755) 26710594 sgs.china@sgs.com

11ax_80M_TX_CH_122_Horizontal-Peak

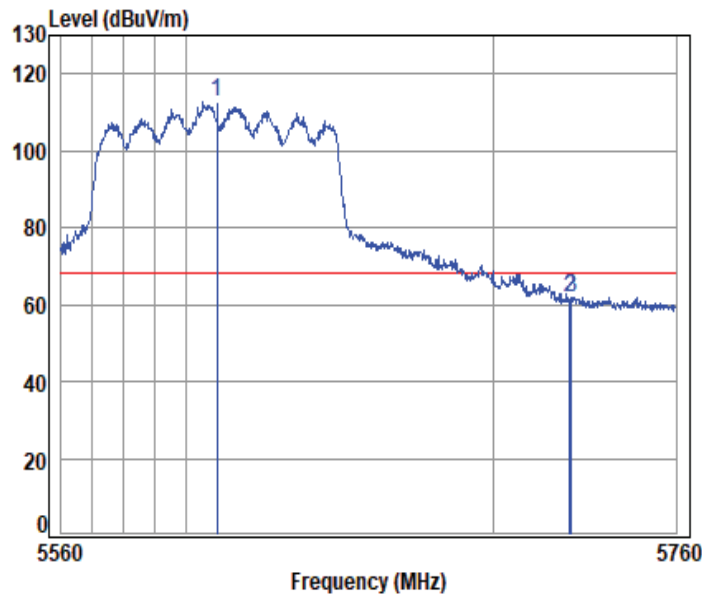

Condition: 3m HORIZONTAL

Job No : 01607WM

Mode : 5610 Band edge

: 5G Wi-Fi 11ax80

	Cable	Ant	Preamp	Read	Limit	Over			
Freq	Loss	Factor	Factor	Level	Level	Line	Limit	Remark	
MHz	dB	dB/m	dB	dBuV	dBuV/m	dBuV/m	dB		
1 pp 5610.000	10.43	33.02	30.69	99.73	112.49	68.20	44.29	peak	
2 5725.000	10.68	33.25	30.72	48.41	61.62	68.20	-6.58	peak	
3 5725.500	10.68	33.25	30.72	48.74	61.95	68.20	-6.25	peak	



11ax_80M_TX_CH_122_Vertical-Peak

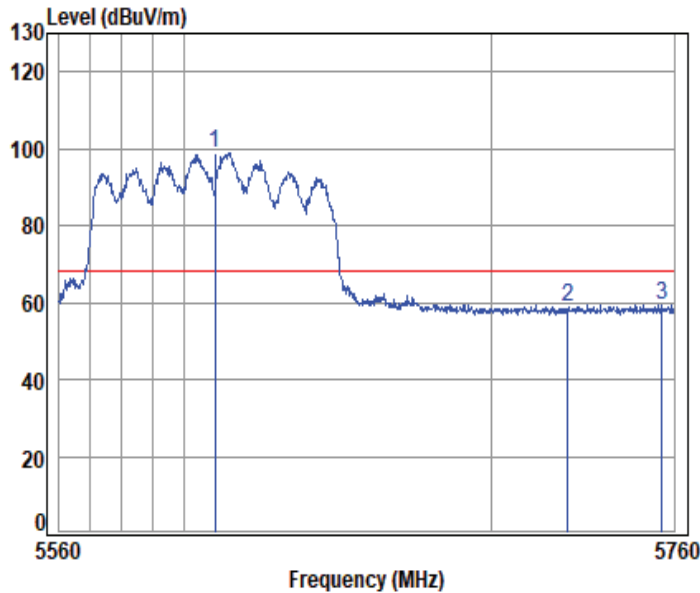

Condition: 3m VERTICAL

Job No : 01607WM

Mode : 5610 Band edge

: 5G Wi-Fi 11ax80

	Cable	Ant	Preamp	Read	Limit	Over			
Freq	Loss	Factor	Factor	Level	Level	Line	Limit	Remark	
MHz	dB	dB/m	dB	dBuV	dBuV/m	dBuV/m	dB		
1 pp 5610.000	10.43	33.02	30.69	86.28	99.04	68.20	30.84	peak	
2 5725.000	10.68	33.25	30.72	45.53	58.74	68.20	-9.46	peak	
3 5756.134	10.82	33.31	30.73	46.12	59.52	68.20	-8.68	peak	



Unless otherwise agreed in writing, this document is issued by the Company subject to its General Conditions of Service printed overleaf, available on request or accessible at <https://www.sgs.com/en/Terms-and-Conditions>. Attention is drawn to the limitation of liability, indemnification and jurisdiction issues defined therein. Any holder of this document is advised that information contained hereon reflects the Company's findings at the time of its intervention only and within the limits of Client's instructions, if any. The Company's sole responsibility is to its Client and this document does not exonerate parties to a transaction from exercising all their rights and obligations under the transaction documents. This document cannot be reproduced except in full, without prior written approval of the Company. Any unauthorized alteration, forgery or falsification of the content or appearance of this document is unlawful and offenders may be prosecuted to the fullest extent of the law. Unless otherwise stated the results shown in this test report refer only to the sample(s) tested and such sample(s) are retained for 30 days only.

Attention: To check the authenticity of testing /inspection report & certificate, please contact us at telephone: (86-755) 8307 1443, or email: CN.Doccheck@sgs.com
 No.1 Workshop, M-10, Middle Section, Science & Technology Park, Nanshan District, Shenzhen, Guangdong, China 518057 t (86-755) 26012053 f (86-755) 26710594 www.sgs.com.cn
 中国·广东·深圳市南山区科技园中区M-10栋1号厂房 邮编: 518057 t (86-755) 26012053 f (86-755) 26710594 sgs.china@sgs.com

11ax_160M_TX_CH_114_Horizontal-Peak

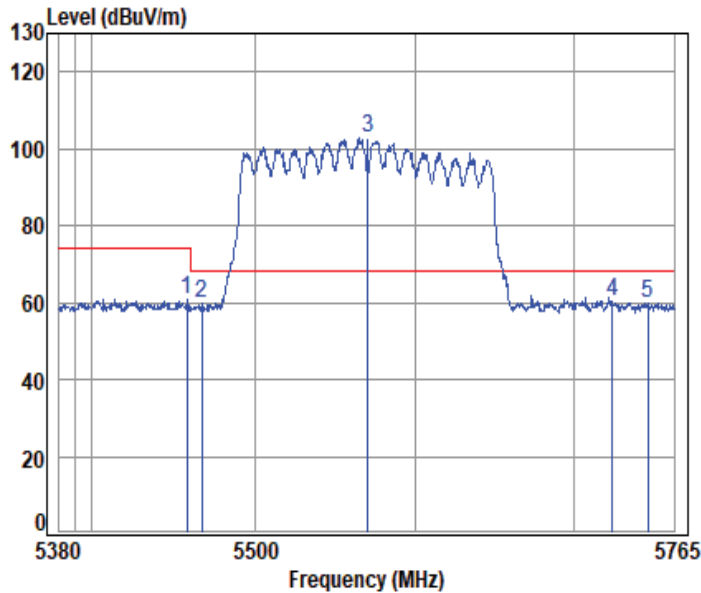

Condition: 3m HORIZONTAL

Job No : 01607WM

Mode : 5570 Band edge

: 5G Wi-Fi 11ax160

	Cable Freq	Loss	Ant Factor	Preamp Factor	Read Level	Limit Level	Over Limit	Remark
	MHz	dB	dB/m	dB	dBuV	dBuV/m	dBuV/m	dB
1	5457.903	10.60	32.90	30.64	48.06	60.92	74.00	-13.08 peak
2	5466.964	10.59	32.90	30.65	46.94	59.78	68.20	-8.42 peak
3 pp	5570.000	10.46	32.94	30.68	89.91	102.63	68.20	34.43 peak
4	5725.000	10.68	33.25	30.72	47.21	60.42	68.20	-7.78 peak
5	5747.892	10.78	33.30	30.73	46.58	59.93	68.20	-8.27 peak



Unless otherwise agreed in writing, this document is issued by the Company subject to its General Conditions of Service printed overleaf, available on request or accessible at <https://www.sgs.com/en/Terms-and-Conditions>. Attention is drawn to the limitation of liability, indemnification and jurisdiction issues defined therein. Any holder of this document is advised that information contained hereon reflects the Company's findings at the time of its intervention only and within the limits of Client's instructions, if any. The Company's sole responsibility is to its Client and this document does not exonerate parties to a transaction from exercising all their rights and obligations under the transaction documents. This document cannot be reproduced except in full, without prior written approval of the Company. Any unauthorized alteration, forgery or falsification of the content or appearance of this document is unlawful and offenders may be prosecuted to the fullest extent of the law. Unless otherwise stated the results shown in this test report refer only to the sample(s) tested and such sample(s) are retained for 30 days only.

Attention: To check the authenticity of testing /inspection report & certificate, please contact us at telephone: (86-755) 8307 1443, or email: CN.Doccheck@sgs.com
 No.1 Workshop, M-10, Middle Section, Science & Technology Park, Nanshan District, Shenzhen, Guangdong, China 518057 t (86-755) 26012053 f (86-755) 26710594 www.sgs.com.cn
 中国·广东·深圳市南山区科技园中区M-10栋1号厂房 邮编: 518057 t (86-755) 26012053 f (86-755) 26710594 sgs.china@sgs.com

11ax_160M_TX_CH_114_Horizontal-Avg

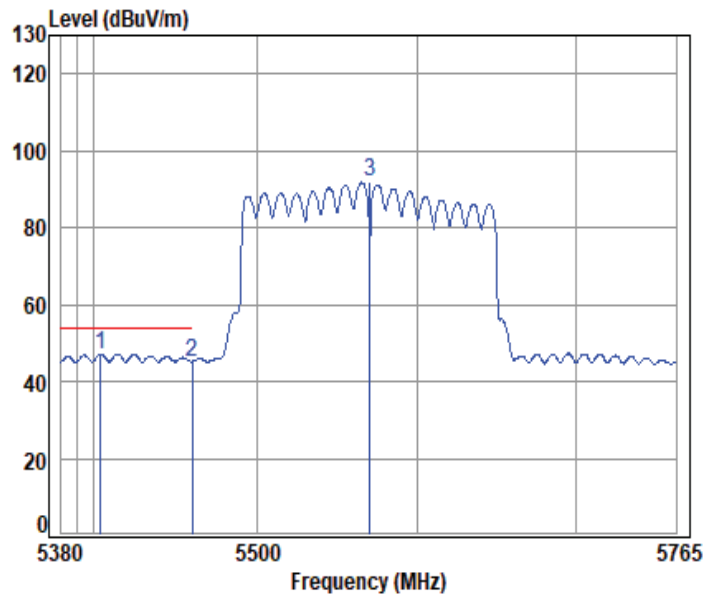

Condition: 3m HORIZONTAL

Job No : 01607WM

Mode : 5570 Band edge

: 5G Wi-Fi 11ax160

	Cable	Ant	Preamp	Read	Limit	Over			
Freq	Loss	Factor	Factor	Level	Level	Line	Limit	Remark	
MHz	dB	dB/m	dB	dBuV	dBuV/m	dBuV/m	dB		
1 pp 5403.851	10.62	32.81	30.63	34.40	47.20	54.00	-6.80	Average	
2 5460.000	10.60	32.90	30.64	32.28	45.14	54.00	-8.86	Average	
3 5570.000	10.46	32.94	30.68	79.00	91.72	-----	-----	Average	



Unless otherwise agreed in writing, this document is issued by the Company subject to its General Conditions of Service printed overleaf, available on request or accessible at <https://www.sgs.com/en/Terms-and-Conditions>. Attention is drawn to the limitation of liability, indemnification and jurisdiction issues defined therein. Any holder of this document is advised that information contained hereon reflects the Company's findings at the time of its intervention only and within the limits of Client's instructions, if any. The Company's sole responsibility is to its Client and this document does not exonerate parties to a transaction from exercising all their rights and obligations under the transaction documents. This document cannot be reproduced except in full, without prior written approval of the Company. Any unauthorized alteration, forgery or falsification of the content or appearance of this document is unlawful and offenders may be prosecuted to the fullest extent of the law. Unless otherwise stated the results shown in this test report refer only to the sample(s) tested and such sample(s) are retained for 30 days only.

Attention: To check the authenticity of testing /inspection report & certificate, please contact us at telephone: (86-755) 8307 1443, or email: CN.Doccheck@sgs.com
 No.1 Workshop, M-10, Middle Section, Science & Technology Park, Nanshan District, Shenzhen, Guangdong, China 518057 t (86-755) 26012053 f (86-755) 26710594 www.sgs.com.cn
 中国·广东·深圳市南山区科技园中区M-10栋1号厂房 邮编: 518057 t (86-755) 26012053 f (86-755) 26710594 sgs.china@sgs.com

11ax_160M_TX_CH_114_Vertical-Peak

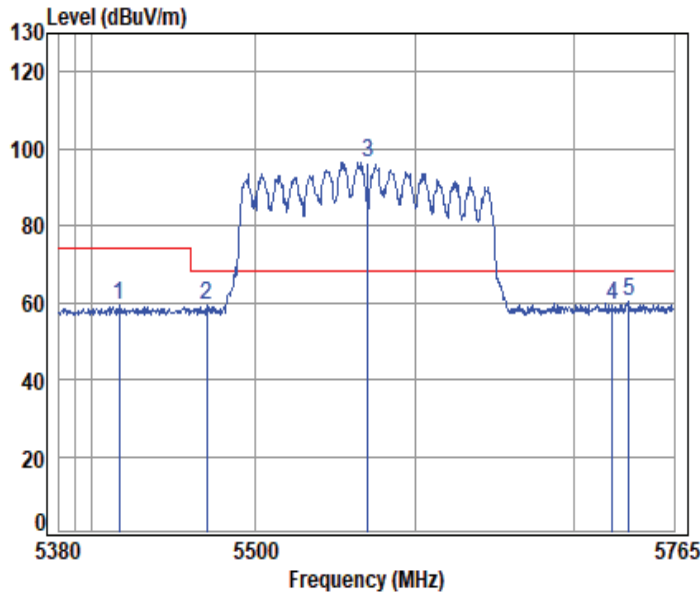

Condition: 3m VERTICAL

Job No : 01607WM

Mode : 5570 Band edge

: 5G Wi-Fi 11ax160

	Cable Freq	Ant Loss	Preamp Factor	Read Level	Limit Level	Over Limit	Remark
	MHz	dB	dB/m	dB	dBuV	dBuV/m	dBuV/m
1	5416.565	10.61	32.83	30.63	46.37	59.18	74.00 -14.82 peak
2	5469.988	10.59	32.90	30.65	46.35	59.19	68.20 -9.01 peak
3 pp	5570.000	10.46	32.94	30.68	83.91	96.63	68.20 28.43 peak
4	5725.000	10.68	33.25	30.72	46.14	59.35	68.20 -8.85 peak
5	5735.986	10.73	33.27	30.73	46.87	60.14	68.20 -8.06 peak



Unless otherwise agreed in writing, this document is issued by the Company subject to its General Conditions of Service printed overleaf, available on request or accessible at <https://www.sgs.com/en/Terms-and-Conditions>. Attention is drawn to the limitation of liability, indemnification and jurisdiction issues defined therein. Any holder of this document is advised that information contained hereon reflects the Company's findings at the time of its intervention only and within the limits of Client's instructions, if any. The Company's sole responsibility is to its Client and this document does not exonerate parties to a transaction from exercising all their rights and obligations under the transaction documents. This document cannot be reproduced except in full, without prior written approval of the Company. Any unauthorized alteration, forgery or falsification of the content or appearance of this document is unlawful and offenders may be prosecuted to the fullest extent of the law. Unless otherwise stated the results shown in this test report refer only to the sample(s) tested and such sample(s) are retained for 30 days only.

Attention: To check the authenticity of testing /inspection report & certificate, please contact us at telephone: (86-755) 8307 1443, or email: CN.Doccheck@sgs.com

11ax_160M_TX_CH_114_Verical-Avg

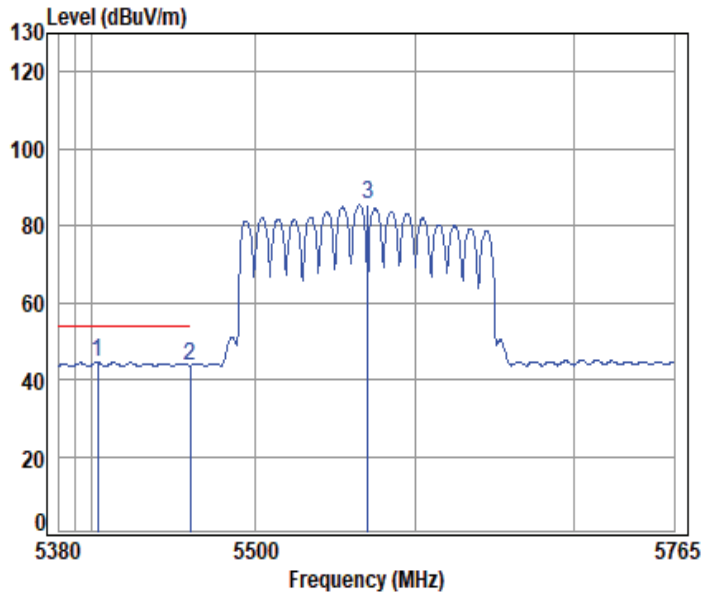

Condition: 3m VERTICAL

Job No : 01607WM

Mode : 5570 Band edge

: 5G Wi-Fi 11ax160

	Cable	Ant	Preamp	Read	Limit	Over			
Freq	Loss	Factor	Factor	Level	Level	Line	Limit	Remark	
MHz	dB	dB/m	dB	dBuV	dBuV/m	dBuV/m	dB		
1 pp 5403.478	10.62	32.81	30.63	31.68	44.48	54.00	-9.52	Average	
2 5460.000	10.60	32.90	30.64	30.85	43.71	54.00	-10.29	Average	
3 5570.000	10.46	32.94	30.68	72.57	85.29	-----	-----	Average	



11a_TX_CH_149_Horizontal

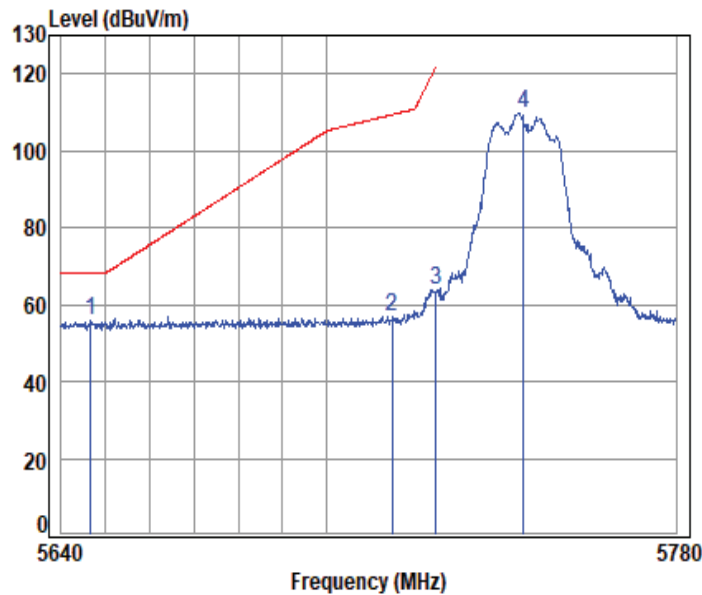

Condition: 3m HORIZONTAL

Job No : 01607WM

Mode : 5745 Band edge

: 5.8G Wi-Fi 11a

	Cable	Ant	Preamp	Read	Limit	Over			
Freq	Loss	Factor	Factor	Level	Level	Line	Limit	Remark	
MHz	dB	dB/m	dB	dBuV	dBuV/m	dBuV/m	dB		
1 pp 5646.642	10.48	33.09	30.64	42.73	55.66	68.20	-12.54	peak	
2 5715.000	10.63	33.23	30.61	43.51	56.76	109.40	-52.64	peak	
3 5725.000	10.68	33.25	30.61	50.37	63.69	122.20	-58.51	peak	
4 5745.000	10.77	33.29	30.60	96.28	109.74	-----	-----	peak	



Unless otherwise agreed in writing, this document is issued by the Company subject to its General Conditions of Service printed overleaf, available on request or accessible at <https://www.sgs.com/en/Terms-and-Conditions>. Attention is drawn to the limitation of liability, indemnification and jurisdiction issues defined therein. Any holder of this document is advised that information contained hereon reflects the Company's findings at the time of its intervention only and within the limits of Client's instructions, if any. The Company's sole responsibility is to its Client and this document does not exonerate parties to a transaction from exercising all their rights and obligations under the transaction documents. This document cannot be reproduced except in full, without prior written approval of the Company. Any unauthorized alteration, forgery or falsification of the content or appearance of this document is unlawful and offenders may be prosecuted to the fullest extent of the law. Unless otherwise stated the results shown in this test report refer only to the sample(s) tested and such sample(s) are retained for 30 days only.

11a_TX_CH_149_Vertical

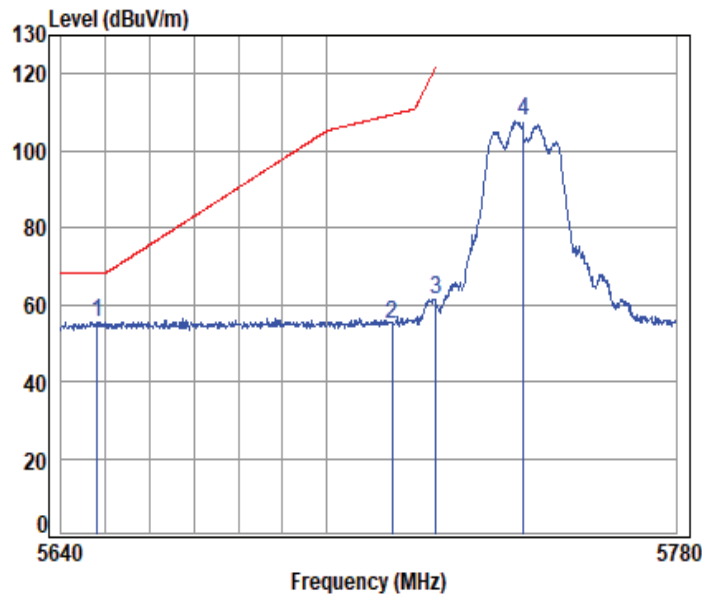

Condition: 3m VERTICAL

Job No : 01607WM

Mode : 5745 Band edge

: 5.8G Wi-Fi 11a

	Cable	Ant	Preamp	Read	Limit	Over		
Freq	Loss	Factor	Factor	Level	Level	Line	Limit	Remark
MHz	dB	dB/m	dB	dBuV	dBuV/m	dBuV/m	dB	
1 pp 5648.026	10.48	33.10	30.64	42.67	55.61	68.20	-12.59	peak
2 5715.000	10.63	33.23	30.61	41.38	54.63	109.40	-54.77	peak
3 5725.000	10.68	33.25	30.61	48.08	61.40	122.20	-60.80	peak
4 5745.000	10.77	33.29	30.60	94.09	107.55	-----	-----	peak



Unless otherwise agreed in writing, this document is issued by the Company subject to its General Conditions of Service printed overleaf, available on request or accessible at <https://www.sgs.com/en/Terms-and-Conditions>. Attention is drawn to the limitation of liability, indemnification and jurisdiction issues defined therein. Any holder of this document is advised that information contained hereon reflects the Company's findings at the time of its intervention only and within the limits of Client's instructions, if any. The Company's sole responsibility is to its Client and this document does not exonerate parties to a transaction from exercising all their rights and obligations under the transaction documents. This document cannot be reproduced except in full, without prior written approval of the Company. Any unauthorized alteration, forgery or falsification of the content or appearance of this document is unlawful and offenders may be prosecuted to the fullest extent of the law. Unless otherwise stated the results shown in this test report refer only to the sample(s) tested and such sample(s) are retained for 30 days only.

Attention: To check the authenticity of testing /inspection report & certificate, please contact us at telephone: (86-755) 8307 1443, or email: CN.Doccheck@sgs.com

11a_TX_CH_165_Horizontal

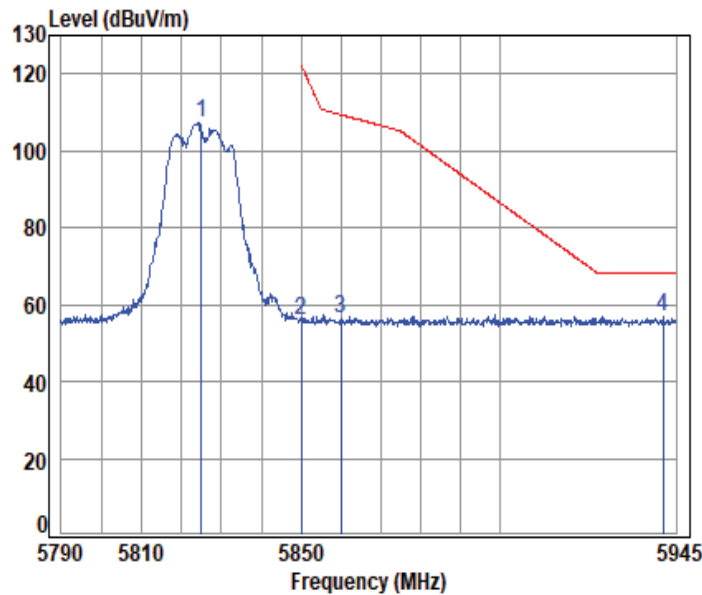

Condition: 3m HORIZONTAL

Job No : 01607WM

Mode : 5825 Band edge

: 5.8G Wi-Fi 11a

	Cable	Ant	Preamp	Read	Limit	Over		
Freq	Loss	Factor	Factor	Level	Level	Line	Limit	Remark
MHz	dB	dB/m	dB	dBuV	dBuV/m	dBuV/m	dB	
1	5825.000	10.99	33.50	30.57	93.22	107.14	-----	----- peak
2	5850.000	10.95	33.60	30.56	41.82	55.81	122.20	-66.39 peak
3	5860.000	10.94	33.58	30.56	42.39	56.35	109.40	-53.05 peak
4 pp	5941.703	10.86	33.58	30.52	42.93	56.85	68.20	-11.35 peak



11a_TX_CH_165_Vertical

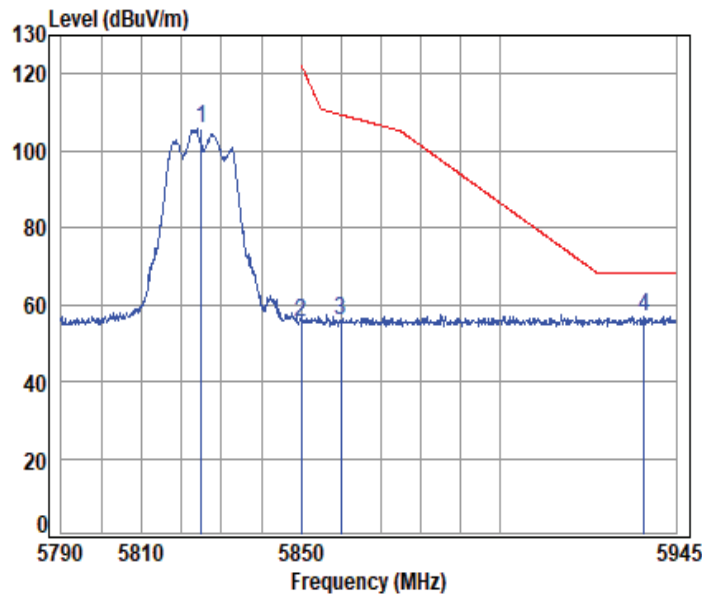

Condition: 3m VERTICAL

Job No : 01607WM

Mode : 5825 Band edge

: 5.8G Wi-Fi 11a

	Cable Freq	Ant Loss	Preamp Factor	Read Level	Limit Level	Over Limit	Remark		
	MHz	dB	dB/m	dB	dBuV	dBuV/m	dBuV/m	dB	
1	5825.000	10.99	33.50	30.57	91.64	105.56	-----	-----	peak
2	5850.000	10.95	33.60	30.56	41.39	55.38	122.20	-66.82	peak
3	5860.000	10.94	33.58	30.56	42.14	56.10	109.40	-53.30	peak
4 pp	5936.839	10.86	33.57	30.53	43.16	57.06	68.20	-11.14	peak



Unless otherwise agreed in writing, this document is issued by the Company subject to its General Conditions of Service printed overleaf, available on request or accessible at <https://www.sgs.com/en/Terms-and-Conditions>. Attention is drawn to the limitation of liability, indemnification and jurisdiction issues defined therein. Any holder of this document is advised that information contained hereon reflects the Company's findings at the time of its intervention only and within the limits of Client's instructions, if any. The Company's sole responsibility is to its Client and this document does not exonerate parties to a transaction from exercising all their rights and obligations under the transaction documents. This document cannot be reproduced except in full, without prior written approval of the Company. Any unauthorized alteration, forgery or falsification of the content or appearance of this document is unlawful and offenders may be prosecuted to the fullest extent of the law. Unless otherwise stated the results shown in this test report refer only to the sample(s) tested and such sample(s) are retained for 30 days only.

Attention: To check the authenticity of testing /inspection report & certificate, please contact us at telephone: (86-755) 8307 1443, or email: CN.Doccheck@sgs.com
 No.1 Workshop, M-10, Middle Section, Science & Technology Park, Nanshan District, Shenzhen, Guangdong, China 518057 t (86-755) 26012053 f (86-755) 26710594 www.sgs.com.cn
 中国·广东·深圳市南山区科技园中区M-10栋1号厂房 邮编: 518057 t (86-755) 26012053 f (86-755) 26710594 sgs.china@sgs.com

11ac_VHT(20M)_TX_CH_149_Horizontal

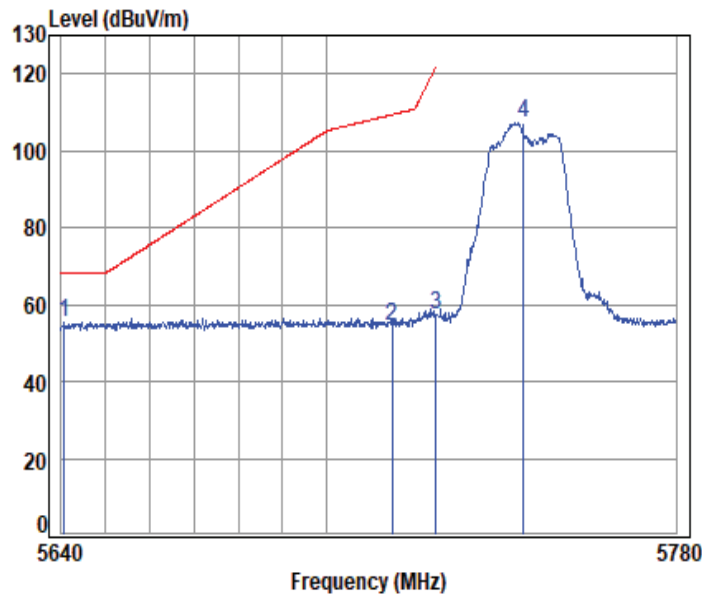

Condition: 3m HORIZONTAL

Job No : 01607WM

Mode : 5745 Band edge

: 5.8G Wi-Fi 11ac20

	Cable	Ant	Preamp	Read	Limit	Over			
Freq	Loss	Factor	Factor	Level	Level	Line	Limit	Remark	
MHz	dB	dB/m	dB	dBuV	dBuV/m	dBuV/m	dB		
1 pp 5640.691	10.47	33.08	30.64	42.66	55.57	68.20	-12.63	peak	
2 5715.000	10.63	33.23	30.61	41.00	54.25	109.40	-55.15	peak	
3 5725.000	10.68	33.25	30.61	44.24	57.56	122.20	-64.64	peak	
4 5745.000	10.77	33.29	30.60	93.79	107.25	-----	-----	peak	



Unless otherwise agreed in writing, this document is issued by the Company subject to its General Conditions of Service printed overleaf, available on request or accessible at <https://www.sgs.com/en/Terms-and-Conditions>. Attention is drawn to the limitation of liability, indemnification and jurisdiction issues defined therein. Any holder of this document is advised that information contained hereon reflects the Company's findings at the time of its intervention only and within the limits of Client's instructions, if any. The Company's sole responsibility is to its Client and this document does not exonerate parties to a transaction from exercising all their rights and obligations under the transaction documents. This document cannot be reproduced except in full, without prior written approval of the Company. Any unauthorized alteration, forgery or falsification of the content or appearance of this document is unlawful and offenders may be prosecuted to the fullest extent of the law. Unless otherwise stated the results shown in this test report refer only to the sample(s) tested and such sample(s) are retained for 30 days only.

Attention: To check the authenticity of testing /inspection report & certificate, please contact us at telephone: (86-755) 8307 1443, or email: CN.Doccheck@sgs.com
 No.1 Workshop, M-10, Middle Section, Science & Technology Park, Nanshan District, Shenzhen, Guangdong, China 518057 t (86-755) 26012053 f (86-755) 26710594 www.sgs.com.cn
 中国·广东·深圳市南山区科技园中区M-10栋1号厂房 邮编: 518057 t (86-755) 26012053 f (86-755) 26710594 sgs.china@sgs.com

11ac_VHT(20M)_TX_CH_149_Vertical

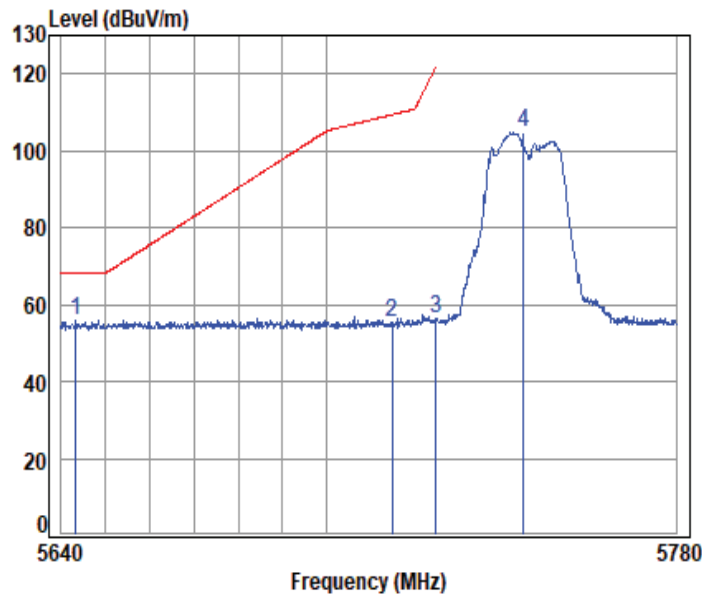

Condition: 3m VERTICAL

Job No : 01607WM

Mode : 5745 Band edge

: 5.8G Wi-Fi 11ac20

	Cable	Ant	Preamp	Read	Limit	Over			
Freq	Loss	Factor	Factor	Level	Level	Line	Limit	Remark	
MHz	dB	dB/m	dB	dBuV	dBuV/m	dBuV/m	dB		
1 pp 5643.182	10.47	33.09	30.64	42.85	55.77	68.20	-12.43	peak	
2 5715.000	10.63	33.23	30.61	41.94	55.19	109.40	-54.21	peak	
3 5725.000	10.68	33.25	30.61	42.97	56.29	122.20	-65.91	peak	
4 5745.000	10.77	33.29	30.60	91.57	105.03	-----	-----	peak	



11ac_VHT(20M)_TX_CH_165_Horizontal

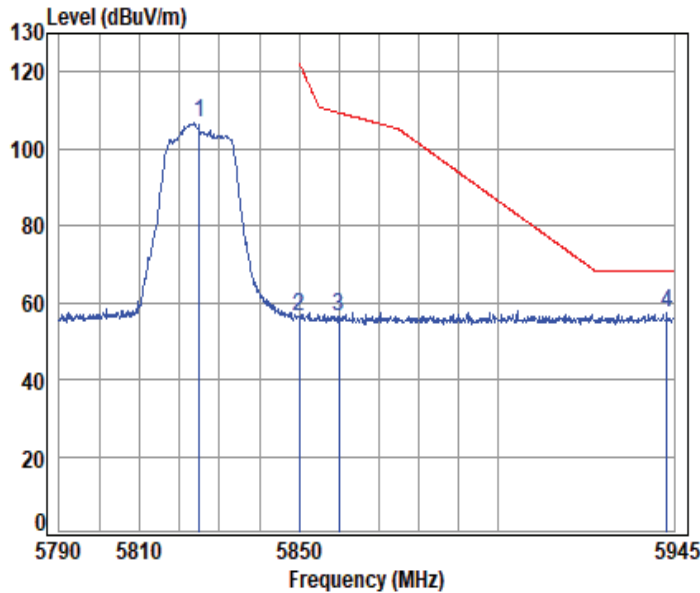

Condition: 3m HORIZONTAL

Job No : 01607WM

Mode : 5825 Band edge

: 5.8G Wi-Fi 11ac20

	Cable Freq	Ant Loss	Preamp Factor	Read Level	Limit Level	Limit Line	Over Limit	Remark
	MHz	dB	dB/m	dB	dBuV	dBuV/m	dBuV/m	dB
1	5825.000	10.99	33.50	30.57	93.09	107.01	-----	peak
2	5850.000	10.95	33.60	30.56	42.31	56.30	122.20	-65.90 peak
3	5860.000	10.94	33.58	30.56	42.16	56.12	109.40	-53.28 peak
4 pp	5943.272	10.86	33.59	30.52	43.28	57.21	68.20	-10.99 peak



Unless otherwise agreed in writing, this document is issued by the Company subject to its General Conditions of Service printed overleaf, available on request or accessible at <https://www.sgs.com/en/Terms-and-Conditions>. Attention is drawn to the limitation of liability, indemnification and jurisdiction issues defined therein. Any holder of this document is advised that information contained hereon reflects the Company's findings at the time of its intervention only and within the limits of Client's instructions, if any. The Company's sole responsibility is to its Client and this document does not exonerate parties to a transaction from exercising all their rights and obligations under the transaction documents. This document cannot be reproduced except in full, without prior written approval of the Company. Any unauthorized alteration, forgery or falsification of the content or appearance of this document is unlawful and offenders may be prosecuted to the fullest extent of the law. Unless otherwise stated the results shown in this test report refer only to the sample(s) tested and such sample(s) are retained for 30 days only.

Attention: To check the authenticity of testing /inspection report & certificate, please contact us at telephone: (86-755) 8307 1443, or email: CN.Doccheck@sgs.com

11ac_VHT(20M)_TX_CH_165_Vercial

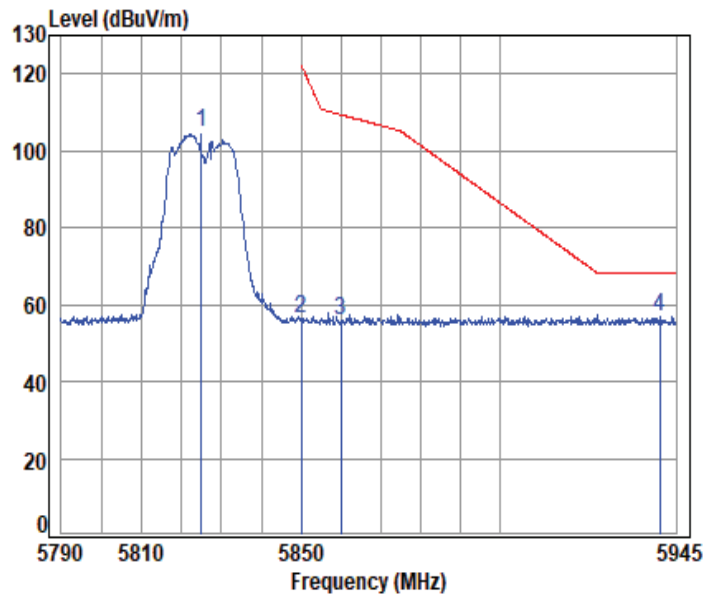

Condition: 3m VERTICAL

Job No : 01607WM

Mode : 5825 Band edge

: 5.8G Wi-Fi 11ac20

	Cable	Ant	Preamp	Read	Limit	Over		
Freq	Loss	Factor	Factor	Level	Level	Line	Limit	Remark
MHz	dB	dB/m	dB	dBuV	dBuV/m	dBuV/m	dB	
1	5825.000	10.99	33.50	30.57	90.66	104.58	-----	----- peak
2	5850.000	10.95	33.60	30.56	42.33	56.32	122.20	-65.88 peak
3	5860.000	10.94	33.58	30.56	41.92	55.88	109.40	-53.52 peak
4	pp 5940.761	10.86	33.58	30.52	42.95	56.87	68.20	-11.33 peak



11ac_VHT(40M)_TX_CH_151_Horizontal

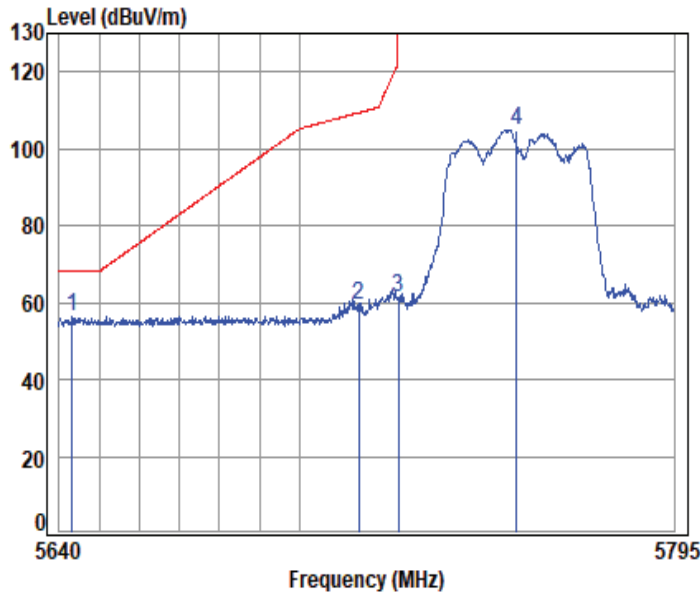

Condition: 3m HORIZONTAL

Job No : 01607WM

Mode : 5755 Band edge

: 5.8G Wi-Fi 11ac40

	Cable	Ant	Preamp	Read	Limit	Over			
Freq	Loss	Factor	Factor	Level	Level	Line	Limit	Remark	
MHz	dB	dB/m	dB	dBuV	dBuV/m	dBuV/m	dB		
1 pp 5643.212	10.47	33.09	30.64	43.53	56.45	68.20	-11.75	peak	
2 5715.000	10.63	33.23	30.61	46.30	59.55	109.40	-49.85	peak	
3 5725.000	10.68	33.25	30.61	47.89	61.21	122.20	-60.99	peak	
4 5755.000	10.81	33.31	30.60	91.34	104.86	-----	-----	peak	



11ac_VHT(40M)_TX_CH_151_Vertical

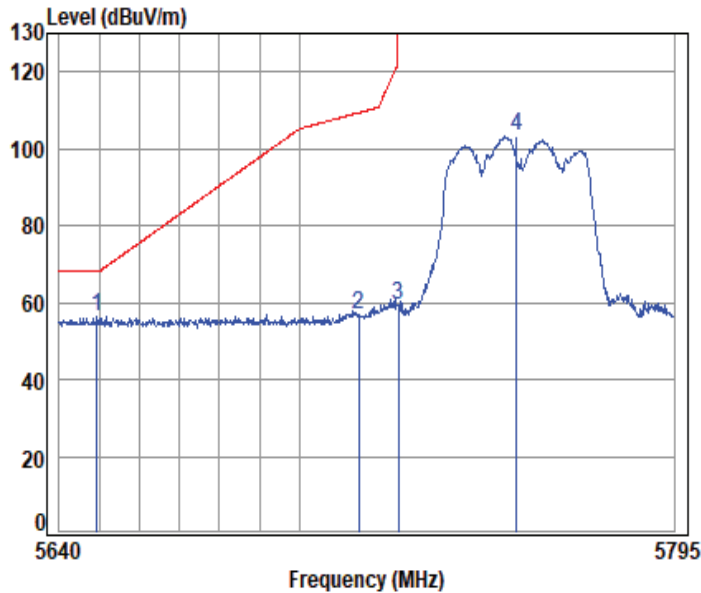

Condition: 3m VERTICAL

Job No : 01607WM

Mode : 5755 Band edge

: 5.8G Wi-Fi 11ac40

	Cable	Ant	Preamp	Read	Limit	Over			
Freq	Loss	Factor	Factor	Level	Level	Line	Limit	Remark	
MHz	dB	dB/m	dB	dBuV	dBuV/m	dBuV/m	dB		
1 pp 5649.335	10.48	33.10	30.64	43.39	56.33	68.20	-11.87	peak	
2 5715.000	10.63	33.23	30.61	43.81	57.06	109.40	-52.34	peak	
3 5725.000	10.68	33.25	30.61	46.16	59.48	122.20	-62.72	peak	
4 5755.000	10.81	33.31	30.60	89.59	103.11	-----	-----	peak	



Unless otherwise agreed in writing, this document is issued by the Company subject to its General Conditions of Service printed overleaf, available on request or accessible at <https://www.sgs.com/en/Terms-and-Conditions>. Attention is drawn to the limitation of liability, indemnification and jurisdiction issues defined therein. Any holder of this document is advised that information contained hereon reflects the Company's findings at the time of its intervention only and within the limits of Client's instructions, if any. The Company's sole responsibility is to its Client and this document does not exonerate parties to a transaction from exercising all their rights and obligations under the transaction documents. This document cannot be reproduced except in full, without prior written approval of the Company. Any unauthorized alteration, forgery or falsification of the content or appearance of this document is unlawful and offenders may be prosecuted to the fullest extent of the law. Unless otherwise stated the results shown in this test report refer only to the sample(s) tested and such sample(s) are retained for 30 days only.

Attention: To check the authenticity of testing /inspection report & certificate, please contact us at telephone: (86-755) 8307 1443, or email: CN.Doccheck@sgs.com
 No.1 Workshop, M-10, Middle Section, Science & Technology Park, Nanshan District, Shenzhen, Guangdong, China 518057 t (86-755) 26012053 f (86-755) 26710594 www.sgs.com.cn
 中国·广东·深圳市南山区科技园中区M-10栋1号厂房 邮编: 518057 t (86-755) 26012053 f (86-755) 26710594 sgs.china@sgs.com

11ac_VHT(40M)_TX_CH_159_Horizontal

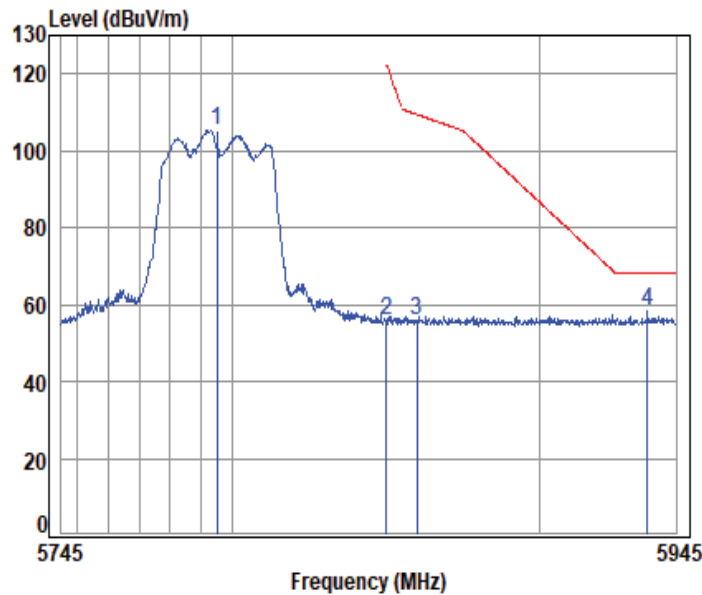

Condition: 3m HORIZONTAL

Job No : 01607WM

Mode : 5795 Band edge

: 5.8G Wi-Fi 11ac40

	Cable Freq	Ant Loss	Preamp Factor	Read Level	Limit Level	Over Limit	Remark		
	MHz	dB	dB/m	dB	dBuV	dBuV/m	dBuV/m	dB	
1	5795.000	11.00	33.39	30.58	91.55	105.36	-----	-----	peak
2	5850.000	10.95	33.60	30.56	41.66	55.65	122.20	-66.55	peak
3	5860.000	10.94	33.58	30.56	41.70	55.66	109.40	-53.74	peak
4 pp	5935.649	10.86	33.57	30.53	44.58	58.48	68.20	-9.72	peak



Unless otherwise agreed in writing, this document is issued by the Company subject to its General Conditions of Service printed overleaf, available on request or accessible at <https://www.sgs.com/en/Terms-and-Conditions>. Attention is drawn to the limitation of liability, indemnification and jurisdiction issues defined therein. Any holder of this document is advised that information contained hereon reflects the Company's findings at the time of its intervention only and within the limits of Client's instructions, if any. The Company's sole responsibility is to its Client and this document does not exonerate parties to a transaction from exercising all their rights and obligations under the transaction documents. This document cannot be reproduced except in full, without prior written approval of the Company. Any unauthorized alteration, forgery or falsification of the content or appearance of this document is unlawful and offenders may be prosecuted to the fullest extent of the law. Unless otherwise stated the results shown in this test report refer only to the sample(s) tested and such sample(s) are retained for 30 days only.

Attention: To check the authenticity of testing /inspection report & certificate, please contact us at telephone: (86-755) 8307 1443, or email: CN.Doccheck@sgs.com
 No.1 Workshop, M-10, Middle Section, Science & Technology Park, Nanshan District, Shenzhen, Guangdong, China 518057 t (86-755) 26012053 f (86-755) 26710594 www.sgs.com.cn
 中国·广东·深圳市南山区科技园中区M-10栋1号厂房 邮编: 518057 t (86-755) 26012053 f (86-755) 26710594 sgs.china@sgs.com

11ac_VHT(40M)_TX_CH_159_Vercial

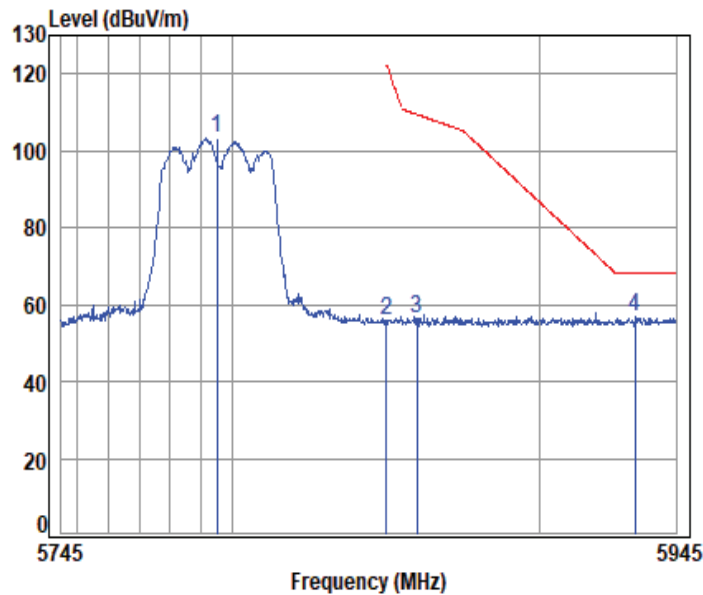

Condition: 3m VERTICAL

Job No : 01607WM

Mode : 5795 Band edge

: 5.8G Wi-Fi 11ac40

	Cable Freq	Ant Loss	Preamp Factor	Read Level	Limit Level	Over Limit	Remark
	MHz	dB	dB/m	dB	dBuV	dBuV/m	dBuV/m
1	5795.000	11.00	33.39	30.58	89.46	103.27	----- peak
2	5850.000	10.95	33.60	30.56	41.82	55.81	122.20 -66.39 peak
3	5860.000	10.94	33.58	30.56	42.35	56.31	109.40 -53.09 peak
4 pp	5931.385	10.86	33.56	30.53	43.01	56.90	68.20 -11.30 peak



11ac_VHT(80M)_TX_CH_155_Horizontal

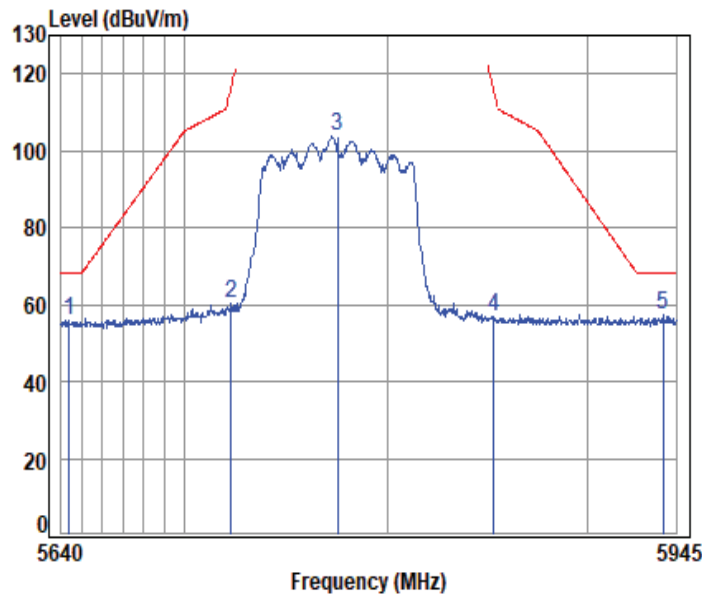

Condition: 3m HORIZONTAL

Job No : 01607WM

Mode : 5775 Band edge

: 5.8G Wi-Fi 11ac80

	Cable	Ant	Preamp	Read	Limit	Over			
	Freq	Loss	Factor	Factor	Level	Level	Line	Limit	Remark
	MHz	dB	dB/m	dB	dBuV	dBuV/m	dBuV/m	dB	
1	5643.863	10.48	33.09	30.64	43.03	55.96	68.20	-12.24	peak
2	5722.582	10.66	33.25	30.61	46.78	60.08	116.69	-56.61	peak
3	5775.000	10.91	33.35	30.59	90.13	103.80	-----	-----	peak
4	5853.041	10.95	33.59	30.56	43.07	57.05	115.27	-58.22	peak
5 pp	5938.429	10.86	33.58	30.52	43.48	57.40	68.20	-10.80	peak



Unless otherwise agreed in writing, this document is issued by the Company subject to its General Conditions of Service printed overleaf, available on request or accessible at <https://www.sgs.com/en/Terms-and-Conditions>. Attention is drawn to the limitation of liability, indemnification and jurisdiction issues defined therein. Any holder of this document is advised that information contained hereon reflects the Company's findings at the time of its intervention only and within the limits of Client's instructions, if any. The Company's sole responsibility is to its Client and this document does not exonerate parties to a transaction from exercising all their rights and obligations under the transaction documents. This document cannot be reproduced except in full, without prior written approval of the Company. Any unauthorized alteration, forgery or falsification of the content or appearance of this document is unlawful and offenders may be prosecuted to the fullest extent of the law. Unless otherwise stated the results shown in this test report refer only to the sample(s) tested and such sample(s) are retained for 30 days only.

Attention: To check the authenticity of testing /inspection report & certificate, please contact us at telephone: (86-755) 8307 1443, or email: CN.Doccheck@sgs.com
 No.1 Workshop, M-10, Middle Section, Science & Technology Park, Nanshan District, Shenzhen, Guangdong, China 518057 t (86-755) 26012053 f (86-755) 26710594 www.sgs.com.cn
 中国·广东·深圳市南山区科技园中区M-10栋1号厂房 邮编: 518057 t (86-755) 26012053 f (86-755) 26710594 sgs.china@sgs.com

11ac_VHT(80M)_TX_CH_155_Vercial

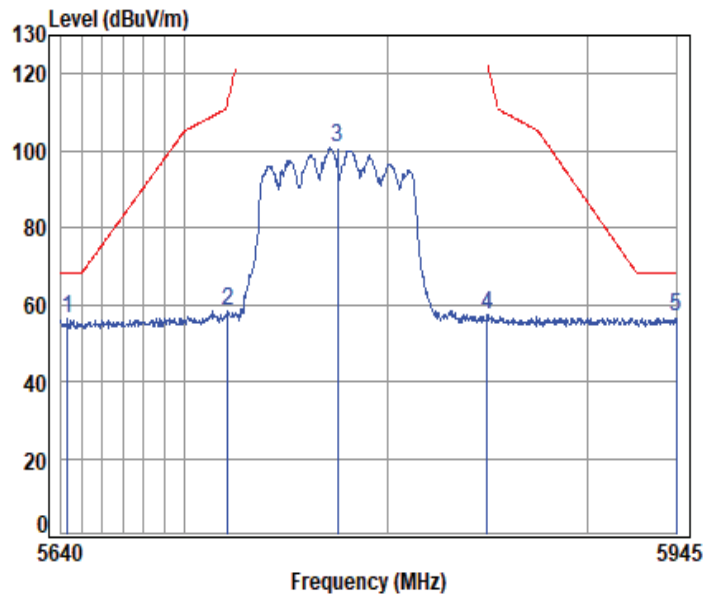

Condition: 3m VERTICAL

Job No : 01607WM

Mode : 5775 Band edge

: 5.8G Wi-Fi 11ac80

	Cable Freq	Ant Loss	Preamp Factor	Read Level	Limit Level	Over Limit	Remark
	MHz	dB	dB/m	dB	dBuV	dBuV/m	dBuV/m
1	5642.971	10.47	33.09	30.64	43.53	56.45	68.20 -11.75 peak
2	5721.075	10.66	33.24	30.61	44.81	58.10	113.25 -55.15 peak
3	5775.000	10.91	33.35	30.59	87.40	101.07	----- peak
4	5849.650	10.96	33.60	30.56	43.23	57.23	----- peak
5 pp	5945.000	10.85	33.59	30.52	42.77	56.69	68.20 -11.51 peak



Unless otherwise agreed in writing, this document is issued by the Company subject to its General Conditions of Service printed overleaf, available on request or accessible at <https://www.sgs.com/en/Terms-and-Conditions>. Attention is drawn to the limitation of liability, indemnification and jurisdiction issues defined therein. Any holder of this document is advised that information contained hereon reflects the Company's findings at the time of its intervention only and within the limits of Client's instructions, if any. The Company's sole responsibility is to its Client and this document does not exonerate parties to a transaction from exercising all their rights and obligations under the transaction documents. This document cannot be reproduced except in full, without prior written approval of the Company. Any unauthorized alteration, forgery or falsification of the content or appearance of this document is unlawful and offenders may be prosecuted to the fullest extent of the law. Unless otherwise stated the results shown in this test report refer only to the sample(s) tested and such sample(s) are retained for 30 days only.

Attention: To check the authenticity of testing /inspection report & certificate, please contact us at telephone: (86-755) 8307 1443, or email: CN.Doccheck@sgs.com
 No.1 Workshop, M-10, Middle Section, Science & Technology Park, Nanshan District, Shenzhen, Guangdong, China 518057 t (86-755) 26012053 f (86-755) 26710594 www.sgs.com.cn
 中国·广东·深圳市南山区科技园中区M-10栋1号厂房 邮编: 518057 t (86-755) 26012053 f (86-755) 26710594 sgs.china@sgs.com

11ax_20M_TX_CH_149_Horizontal

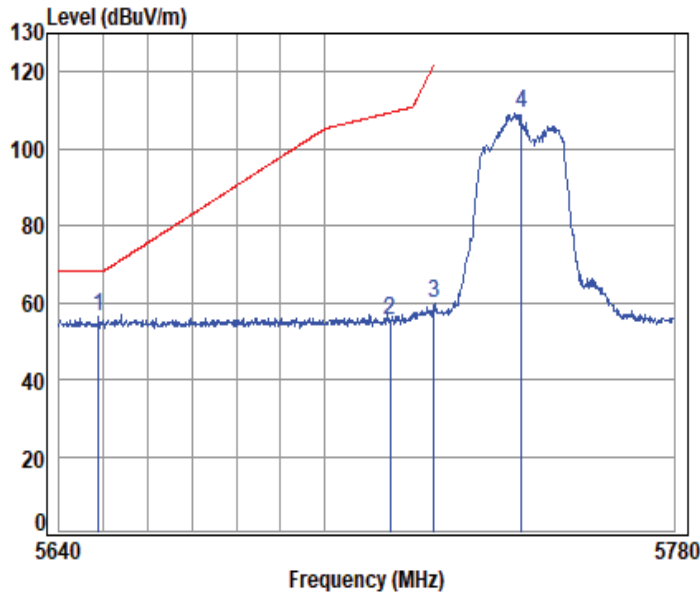

Condition: 3m HORIZONTAL

Job No : 01607WM

Mode : 5745 Band edge

: 5.8G Wi-Fi 11ax20

	Cable	Ant	Preamp	Read	Limit	Over			
Freq	Loss	Factor	Factor	Level	Level	Line	Limit	Remark	
MHz	dB	dB/m	dB	dBuV	dBuV/m	dBuV/m	dB		
1 pp 5648.857	10.48	33.10	30.64	43.21	56.15	68.20	-12.05	peak	
2 5715.000	10.63	33.23	30.61	41.97	55.22	109.40	-54.18	peak	
3 5725.000	10.68	33.25	30.61	46.36	59.68	122.20	-62.52	peak	
4 5745.000	10.77	33.29	30.60	95.66	109.12	-----	-----	peak	



Unless otherwise agreed in writing, this document is issued by the Company subject to its General Conditions of Service printed overleaf, available on request or accessible at <https://www.sgs.com/en/Terms-and-Conditions>. Attention is drawn to the limitation of liability, indemnification and jurisdiction issues defined therein. Any holder of this document is advised that information contained hereon reflects the Company's findings at the time of its intervention only and within the limits of Client's instructions, if any. The Company's sole responsibility is to its Client and this document does not exonerate parties to a transaction from exercising all their rights and obligations under the transaction documents. This document cannot be reproduced except in full, without prior written approval of the Company. Any unauthorized alteration, forgery or falsification of the content or appearance of this document is unlawful and offenders may be prosecuted to the fullest extent of the law. Unless otherwise stated the results shown in this test report refer only to the sample(s) tested and such sample(s) are retained for 30 days only.

Attention: To check the authenticity of testing /inspection report & certificate, please contact us at telephone: (86-755) 8307 1443, or email: CN.Doccheck@sgs.com
 No.1 Workshop, M-10, Middle Section, Science & Technology Park, Nanshan District, Shenzhen, Guangdong, China 518057 t (86-755) 26012053 f (86-755) 26710594 www.sgs.com.cn
 中国·广东·深圳市南山区科技园中区M-10栋1号厂房 邮编: 518057 t (86-755) 26012053 f (86-755) 26710594 sgs.china@sgs.com

11ax_20M_TX_CH_149_Vercial

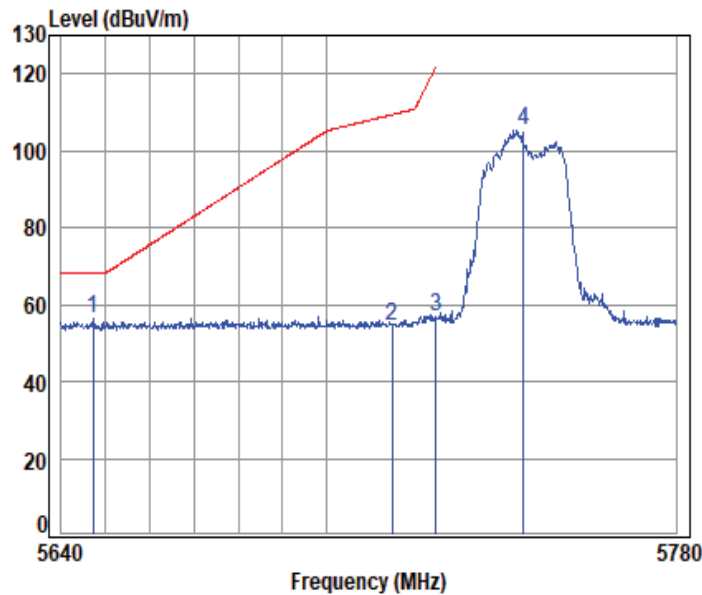

Condition: 3m VERTICAL

Job No : 01607WM

Mode : 5745 Band edge

: 5.8G Wi-Fi 11ax20

	Cable	Ant	Preamp	Read	Limit	Over		
Freq	Loss	Factor	Factor	Level	Level	Line	Limit	Remark
MHz	dB	dB/m	dB	dBuV	dBuV/m	dBuV/m	dB	
1 pp 5647.196	10.48	33.09	30.64	43.27	56.20	68.20	-12.00	peak
2 5715.000	10.63	33.23	30.61	41.35	54.60	109.40	-54.80	peak
3 5725.000	10.68	33.25	30.61	43.42	56.74	122.20	-65.46	peak
4 5745.000	10.77	33.29	30.60	91.78	105.24	-----	-----	peak



11ax_20M_TX_CH_165_Horizontal

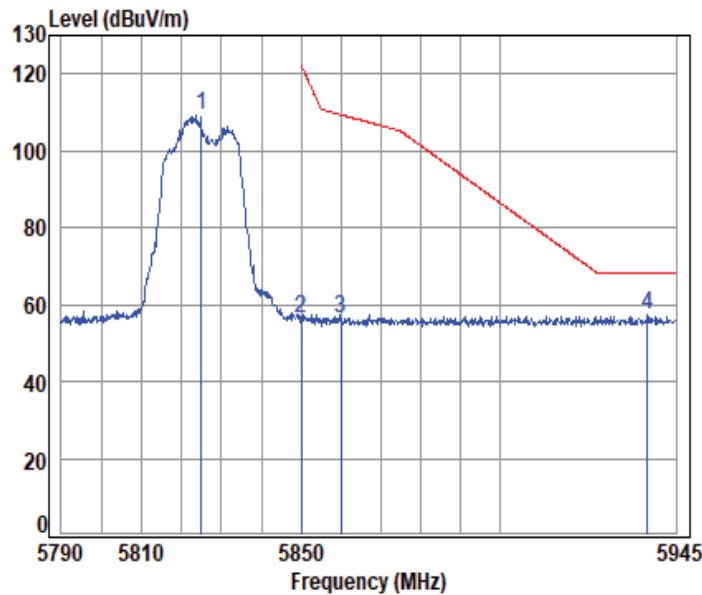

Condition: 3m HORIZONTAL

Job No : 01607WM

Mode : 5825 Band edge

: 5.8G Wi-Fi 11ax20

	Cable Freq	Loss	Ant Factor	Preamp Factor	Read Level	Limit Level	Limit Line	Over Limit	Remark
	MHz	dB	dB/m	dB	dBuV	dBuV/m	dBuV/m	dB	
1	5825.000	10.99	33.50	30.57	95.23	109.15	-----	-----	peak
2	5850.000	10.95	33.60	30.56	42.14	56.13	122.20	-66.07	peak
3	5860.000	10.94	33.58	30.56	42.45	56.41	109.40	-52.99	peak
4 pp	5937.780	10.86	33.58	30.52	43.59	57.51	68.20	-10.69	peak



11ax_20M_TX_CH_165_Vercial

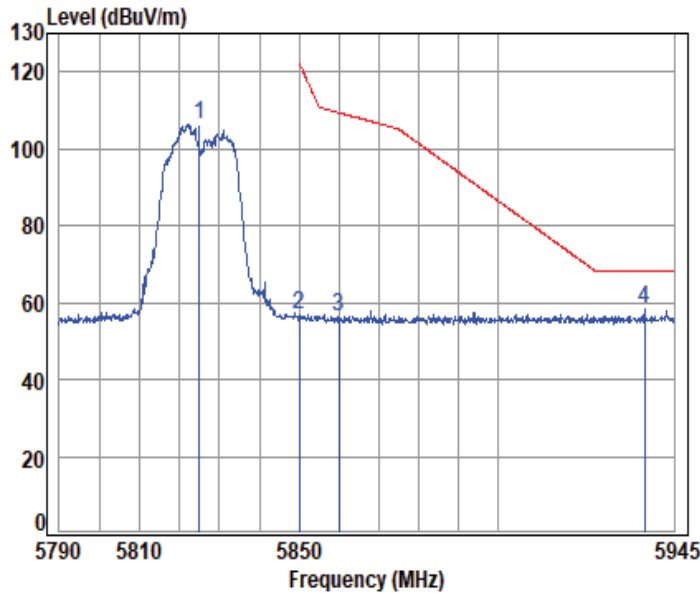

Condition: 3m VERTICAL

Job No : 01607WM

Mode : 5825 Band edge

: 5.8G Wi-Fi 11ax20

	Cable Freq	Ant Loss	Preamp Factor	Read Level	Limit Level	Over Limit	Remark
	MHz	dB	dB/m	dB	dBuV	dBuV/m	dBuV/m
1	5825.000	10.99	33.50	30.57	92.24	106.16	----- peak
2	5850.000	10.95	33.60	30.56	42.75	56.74	122.20 -65.46 peak
3	5860.000	10.94	33.58	30.56	42.26	56.22	109.40 -53.18 peak
4 pp	5937.466	10.86	33.57	30.53	44.25	58.15	68.20 -10.05 peak



Unless otherwise agreed in writing, this document is issued by the Company subject to its General Conditions of Service printed overleaf, available on request or accessible at <https://www.sgs.com/en/Terms-and-Conditions>. Attention is drawn to the limitation of liability, indemnification and jurisdiction issues defined therein. Any holder of this document is advised that information contained hereon reflects the Company's findings at the time of its intervention only and within the limits of Client's instructions, if any. The Company's sole responsibility is to its Client and this document does not exonerate parties to a transaction from exercising all their rights and obligations under the transaction documents. This document cannot be reproduced except in full, without prior written approval of the Company. Any unauthorized alteration, forgery or falsification of the content or appearance of this document is unlawful and offenders may be prosecuted to the fullest extent of the law. Unless otherwise stated the results shown in this test report refer only to the sample(s) tested and such sample(s) are retained for 30 days only.

Attention: To check the authenticity of testing /inspection report & certificate, please contact us at telephone: (86-755) 8307 1443, or email: CN.Doccheck@sgs.com
 No.1 Workshop, M-10, Middle Section, Science & Technology Park, Nanshan District, Shenzhen, Guangdong, China 518057 t (86-755) 26012053 f (86-755) 26710594 www.sgs.com.cn
 中国·广东·深圳市南山区科技园中区M-10栋1号厂房 邮编: 518057 t (86-755) 26012053 f (86-755) 26710594 sgs.china@sgs.com

11ax_40M_TX_CH_151_Horizontal

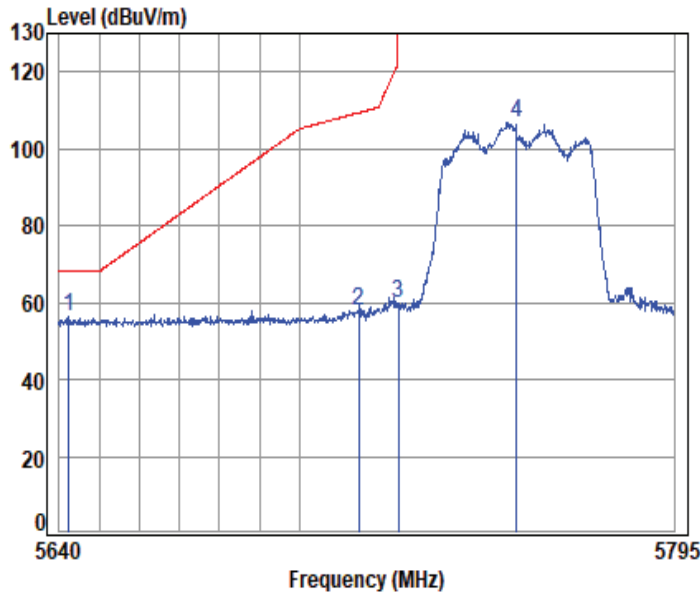

Condition: 3m HORIZONTAL

Job No : 01607WM

Mode : 5755 Band edge

: 5.8G Wi-Fi 11ax40

	Cable	Ant	Preamp	Read	Limit	Over			
Freq	Loss	Factor	Factor	Level	Level	Line	Limit	Remark	
MHz	dB	dB/m	dB	dBuV	dBuV/m	dBuV/m	dB		
1 pp 5642.447	10.47	33.08	30.64	43.41	56.32	68.20	-11.88	peak	
2 5715.000	10.63	33.23	30.61	44.40	57.65	109.40	-51.75	peak	
3 5725.000	10.68	33.25	30.61	46.52	59.84	122.20	-62.36	peak	
4 5755.000	10.81	33.31	30.60	93.28	106.80	-----	-----	peak	



11ax_40M_TX_CH_151_Vertical

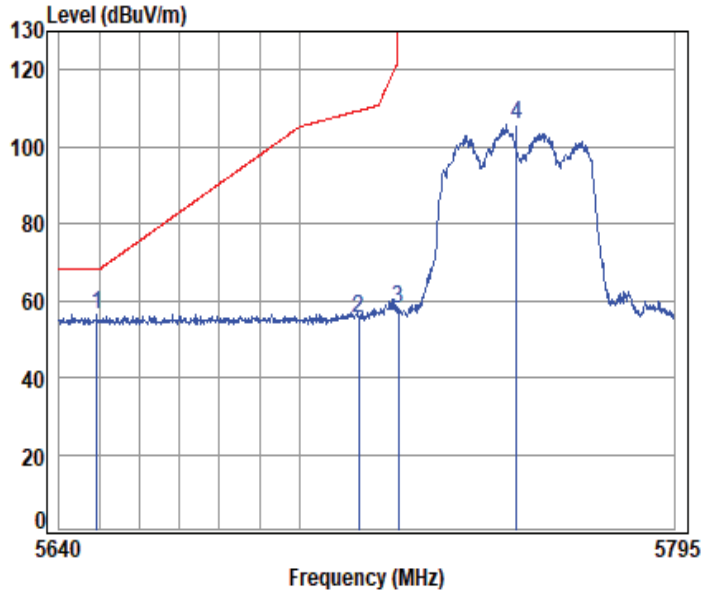

Condition: 3m VERTICAL

Job No : 01607WM

Mode : 5755 Band edge

: 5.8G Wi-Fi 11ax40

	Cable	Ant	Preamp	Read	Limit	Over			
Freq	Loss	Factor	Factor	Level	Level	Line	Limit	Remark	
MHz	dB	dB/m	dB	dBuV	dBuV/m	dBuV/m	dB		
1 pp 5649.335	10.48	33.10	30.64	43.27	56.21	68.20	-11.99	peak	
2 5715.000	10.63	33.23	30.61	42.31	55.56	109.40	-53.84	peak	
3 5725.000	10.68	33.25	30.61	44.43	57.75	122.20	-64.45	peak	
4 5755.000	10.81	33.31	30.60	92.07	105.59	-----	-----	peak	



11ax_40M_TX_CH_159_Horizontal

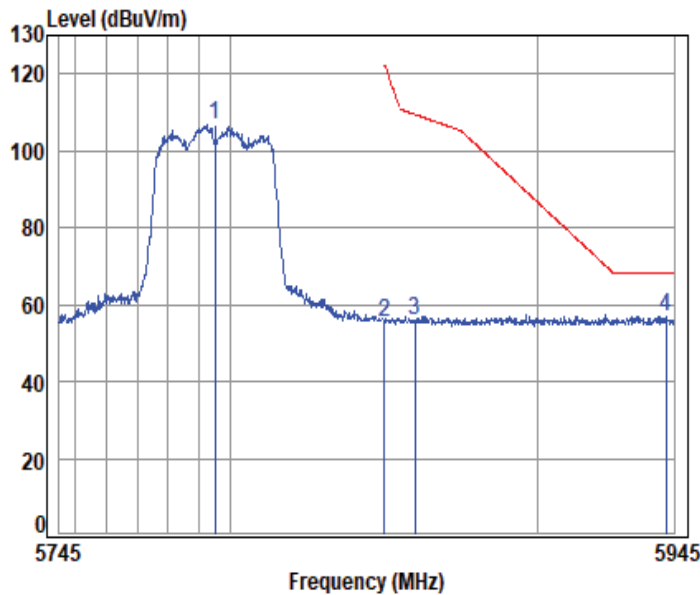

Condition: 3m HORIZONTAL

Job No : 01607WM

Mode : 5795 Band edge

: 5.8G Wi-Fi 11ax40

	Cable Freq	Ant Loss	Preamp Factor	Read Level	Limit Level	Over Limit	Remark		
	MHz	dB	dB/m	dB	dBuV	dBuV/m	dBuV/m	dB	
1	5795.000	11.00	33.39	30.58	92.88	106.69	-----	-----	peak
2	5850.000	10.95	33.60	30.56	41.35	55.34	122.20	-66.86	peak
3	5860.000	10.94	33.58	30.56	41.97	55.93	109.40	-53.47	peak
4 pp	5942.356	10.86	33.58	30.52	43.05	56.97	68.20	-11.23	peak



11ax_40M_TX_CH_159_Vercial

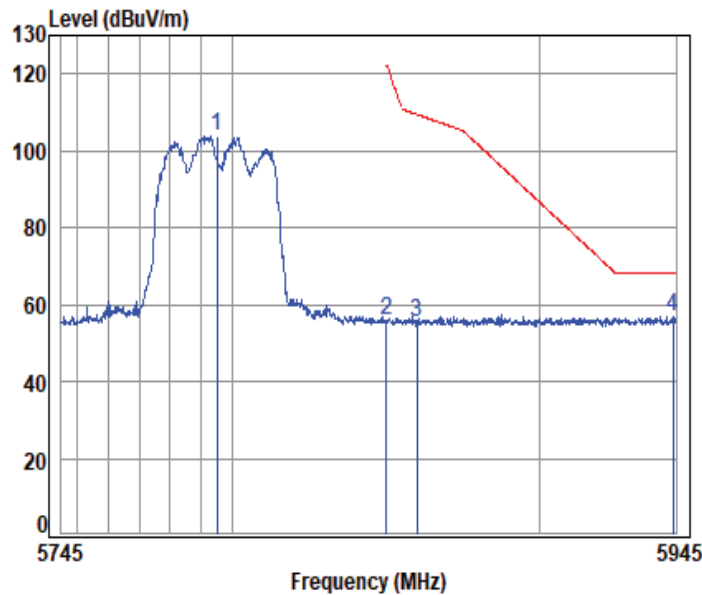

Condition: 3m VERTICAL

Job No : 01607WM

Mode : 5795 Band edge

: 5.8G Wi-Fi 11ax40

	Cable Freq	Ant Loss	Preamp Factor	Read Level	Limit Level	Over Limit	Remark		
	MHz	dB	dB/m	dB	dBuV	dBuV/m	dBuV/m	dB	
1	5795.000	11.00	33.39	30.58	90.15	103.96	-----	-----	peak
2	5850.000	10.95	33.60	30.56	41.67	55.66	122.20	-66.54	peak
3	5860.000	10.94	33.58	30.56	41.31	55.27	109.40	-54.13	peak
4 pp	5943.983	10.85	33.59	30.52	42.99	56.91	68.20	-11.29	peak



Unless otherwise agreed in writing, this document is issued by the Company subject to its General Conditions of Service printed overleaf, available on request or accessible at <https://www.sgs.com/en/Terms-and-Conditions>. Attention is drawn to the limitation of liability, indemnification and jurisdiction issues defined therein. Any holder of this document is advised that information contained hereon reflects the Company's findings at the time of its intervention only and within the limits of Client's instructions, if any. The Company's sole responsibility is to its Client and this document does not exonerate parties to a transaction from exercising all their rights and obligations under the transaction documents. This document cannot be reproduced except in full, without prior written approval of the Company. Any unauthorized alteration, forgery or falsification of the content or appearance of this document is unlawful and offenders may be prosecuted to the fullest extent of the law. Unless otherwise stated the results shown in this test report refer only to the sample(s) tested and such sample(s) are retained for 30 days only.

Attention: To check the authenticity of testing /inspection report & certificate, please contact us at telephone: (86-755) 8307 1443, or email: CN.Doccheck@sgs.com
 No.1 Workshop, M-10, Middle Section, Science & Technology Park, Nanshan District, Shenzhen, Guangdong, China 518057 t (86-755) 26012053 f (86-755) 26710594 www.sgs.com.cn
 中国·广东·深圳市南山区科技园中区M-10栋1号厂房 邮编: 518057 t (86-755) 26012053 f (86-755) 26710594 sgs.china@sgs.com

11ax_80M_TX_CH_155_Horizontal

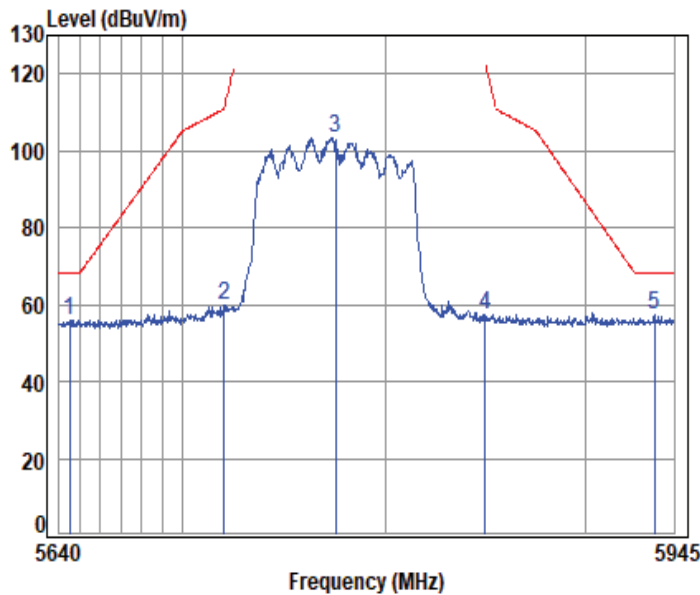

Condition: 3m HORIZONTAL

Job No : 01607WM

Mode : 5775 Band edge

: 5.8G Wi-Fi 11ax80

	Cable	Ant	Preamp	Read	Limit	Over			
	Freq	Loss	Factor	Factor	Level	Level	Line	Limit	Remark
	MHz	dB	dB/m	dB	dBuV	dBuV/m	dBuV/m	dB	
1	5645.052	10.48	33.09	30.64	43.00	55.93	68.20	-12.27	peak
2	5720.171	10.65	33.24	30.61	46.47	59.75	111.19	-51.44	peak
3	5775.000	10.91	33.35	30.59	89.80	103.47	-----	-----	peak
4	5849.650	10.96	33.60	30.56	43.54	57.54	-----	-----	peak
5 pp	5934.989	10.86	33.57	30.53	43.49	57.39	68.20	-10.81	peak



Unless otherwise agreed in writing, this document is issued by the Company subject to its General Conditions of Service printed overleaf, available on request or accessible at <https://www.sgs.com/en/Terms-and-Conditions>. Attention is drawn to the limitation of liability, indemnification and jurisdiction issues defined therein. Any holder of this document is advised that information contained hereon reflects the Company's findings at the time of its intervention only and within the limits of Client's instructions, if any. The Company's sole responsibility is to its Client and this document does not exonerate parties to a transaction from exercising all their rights and obligations under the transaction documents. This document cannot be reproduced except in full, without prior written approval of the Company. Any unauthorized alteration, forgery or falsification of the content or appearance of this document is unlawful and offenders may be prosecuted to the fullest extent of the law. Unless otherwise stated the results shown in this test report refer only to the sample(s) tested and such sample(s) are retained for 30 days only.

Attention: To check the authenticity of testing /inspection report & certificate, please contact us at telephone: (86-755) 8307 1443, or email: CN.Doccheck@sgs.com
 No.1 Workshop, M-10, Middle Section, Science & Technology Park, Nanshan District, Shenzhen, Guangdong, China 518057 t (86-755) 26012053 f (86-755) 26710594 www.sgs.com.cn
 中国·广东·深圳市南山区科技园中区M-10栋1号厂房 邮编: 518057 t (86-755) 26012053 f (86-755) 26710594 sgs.china@sgs.com

11ax_80M_TX_CH_155_Vercial

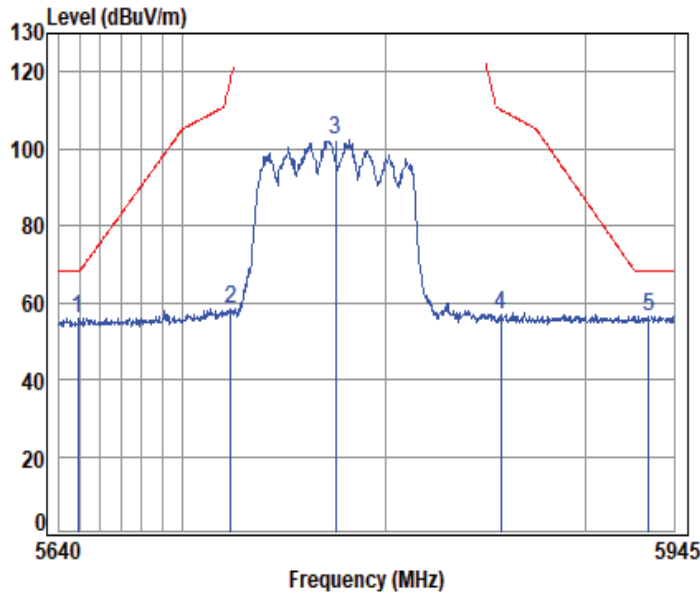

Condition: 3m VERTICAL

Job No : 01607WM

Mode : 5775 Band edge

: 5.8G Wi-Fi 11ax80

	Cable	Ant	Preamp	Read	Limit	Over			
Freq	Loss	Factor	Factor	Level	Level	Line	Limit	Remark	
MHz	dB	dB/m	dB	dBuV	dBuV/m	dBuV/m	dB		
1	5649.216	10.48	33.10	30.64	42.75	55.69	68.20	-12.51 peak	
2	5723.486	10.67	33.25	30.61	44.80	58.11	118.75	-60.64 peak	
3	5775.000	10.91	33.35	30.59	88.52	102.19	-----	----- peak	
4	5857.357	10.95	33.59	30.56	43.09	57.07	110.14	-53.07 peak	
5	pp 5932.177	10.86	33.56	30.53	42.70	56.59	68.20	-11.61 peak	



Unless otherwise agreed in writing, this document is issued by the Company subject to its General Conditions of Service printed overleaf, available on request or accessible at <https://www.sgs.com/en/Terms-and-Conditions>. Attention is drawn to the limitation of liability, indemnification and jurisdiction issues defined therein. Any holder of this document is advised that information contained hereon reflects the Company's findings at the time of its intervention only and within the limits of Client's instructions, if any. The Company's sole responsibility is to its Client and this document does not exonerate parties to a transaction from exercising all their rights and obligations under the transaction documents. This document cannot be reproduced except in full, without prior written approval of the Company. Any unauthorized alteration, forgery or falsification of the content or appearance of this document is unlawful and offenders may be prosecuted to the fullest extent of the law. Unless otherwise stated the results shown in this test report refer only to the sample(s) tested and such sample(s) are retained for 30 days only.

Attention: To check the authenticity of testing /inspection report & certificate, please contact us at telephone: (86-755) 8307 1443, or email: CN.Doccheck@sgs.com

7.6 Channel Move Time

Test Requirement KDB 905462 D02 Section 5.1
 Test Method: KDB 905462 D02 Section 7.8.3

Limit:

Test item	Limit	Applicability	
		Master Device or client with Radar Detection	Client without Radar Detection
Non-occupancy period	Minimum 30 minutes	Yes	Not required
Channel Availability Check Time	60 seconds	Yes	Not required
Channel Move Time	10 seconds See Note 1.	Yes	Yes
Channel Closing Transmission Time	200 milliseconds + an aggregate of 60 milliseconds over remaining 10 second period. See Notes 1 and 2.	Yes	Yes
U-NII Detection Bandwidth	Minimum 100% of the U-NII 99% transmission power bandwidth. See Note 3.	Yes	Not required

Note 1: Channel Move Time and the Channel Closing Transmission Time should be performed with Radar Type 0. The measurement timing begins at the end of the Radar Type 0 burst.

Note 2: The Channel Closing Transmission Time is comprised of 200 milliseconds starting at the beginning of the Channel Move Time plus any additional intermittent control signals required to facilitate a Channel move (an aggregate of 60 milliseconds) during the remainder of the 10 second period. The aggregate duration of control signals will not count quiet periods in between transmissions.

Note 3: During the U-NII Detection Bandwidth detection test, radar type 0 should be used. For each frequency step the minimum percentage of detection is 90 percent. Measurements are performed with no data traffic.

7.6.1 E.U.T. Operation

Operating Environment:

Temperature: 25.6 °C Humidity: 41.0 % RH Atmospheric Pressure: 1020 mbar



7.6.2 Test Mode Description

Pre-scan / Final test	Mode Code	Description
Final test	13	Normal operating_Keep the EUT communication with the companion device.

7.6.3 Test Setup Diagram

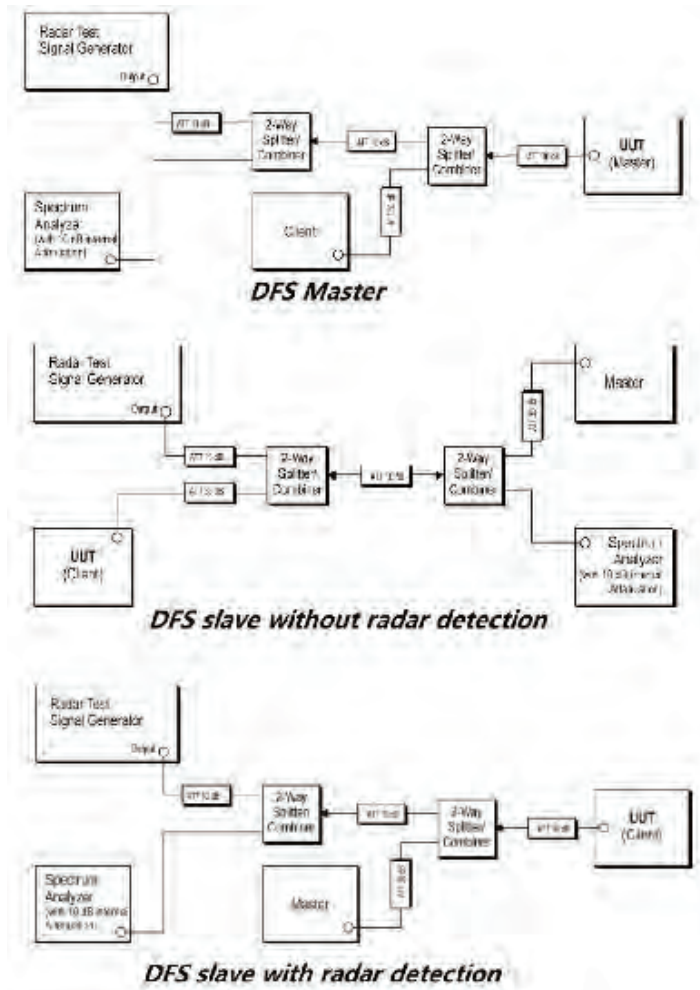

7.6.4 Measurement Procedure and Data

- 1) The radar pulse generator is setup to provide a pulse at frequency that the master and client are operating. A type 0 radar pulse with a 1us pulse width and a 1428us PRI is used for the testing.
- 2) The vector signal generator is adjusted to provide the radar burst (18 pulses) at the level of approximately -61dBm at the antenna port of the master device.
- 3) A trigger is provided from the pulse generator to the DFS monitoring system in order to capture the traffic and the occurrence of the radar pulse.
- 4) EUT will associate with the master at channel. The file "iperf.exe" specified by the FCC is streamed from the PC 2 through the master and the client device to the PC 1 and played in full motion video using Media Player Classic Ver. 6.4.8.6 in order to properly load the network for the entire period of the test.
- 5) When radar burst with a level equal to the DFS Detection Threshold +1dB is generated on the operating channel of the U-NII device. At time T0 the radar waveform generator sends a burst of pulse of the radar waveform at Detection Threshold +1dB.
- 6) Observe the transmissions of the EUT at the end of the radar Burst on the Operating Channel. Measure and record the transmissions from the UUT during the observation time (Channel Move Time). One 15 seconds plot is reported for the Short Pulse Radar Type 0. The plot for the Short Pulse Radar Types start at the end of the radar burst. The Channel Move Time will be calculated based on the zoom in 600ms plot of the Short Pulse Radar Type.
- 7) Measurement of the aggregate duration of the Channel Closed Transmission Time method. With the spectrum analyzer set to zero span tuned to the center frequency of the EUT operating channel at the radar simulated frequency, peak detection, and max hold, the dwell time per bin is given by: $Dwell (0.3ms) = S (3.8300ms) / B (4000)$; where Dwell is the dwell time per spectrum analyzer sampling bin, S is sweep time and B is the number of spectrum analyzer sampling bins. An upper bound of the aggregate duration of the intermittent control signals of Channel Closing Transmission Time is calculated by: $C (ms) = N \times Dwell (0.3ms)$; where C is the Closing Time, N is the number of spectrum analyzer sampling bins (intermittent control signals) showing a U-NII transmission and Dwell is the dwell time per bin.
- 8) Measurement the EUT for more than 30 minutes following the channel move time to verify that no transmission or beacons occur on this channel.

Please Refer to Appendix for Details



Unless otherwise agreed in writing, this document is issued by the Company subject to its General Conditions of Service printed overleaf, available on request or accessible at <https://www.sgs.com/en/Terms-and-Conditions>. Attention is drawn to the limitation of liability, indemnification and jurisdiction issues defined therein. Any holder of this document is advised that information contained hereon reflects the Company's findings at the time of its intervention only and within the limits of Client's instructions, if any. The Company's sole responsibility is to its Client and this document does not exonerate parties to a transaction from exercising all their rights and obligations under the transaction documents. This document cannot be reproduced except in full, without prior written approval of the Company. Any unauthorized alteration, forgery or falsification of the content or appearance of this document is unlawful and offenders may be prosecuted to the fullest extent of the law. Unless otherwise stated the results shown in this test report refer only to the sample(s) tested and such sample(s) are retained for 30 days only.

Attention: To check the authenticity of testing /inspection report & certificate, please contact us at telephone: (86-755) 8307 1443, or email: CN.Doccheck@sgs.com

7.7 Duty Cycle

Test Requirement ANSI C63.10 (2013) Section 12.2
 Test Method: ANSI C63.10 (2013) Section 12.2

7.7.1 E.U.T. Operation

Operating Environment:
 Temperature: 25.1 °C Humidity: 40.2 % RH Atmospheric Pressure: 1020 mbar

7.7.2 Test Mode Description

Pre-scan / Final test	Mode Code	Description
Final test	09	TX mode (U-NII-1)_Keep the EUT in continuously transmitting mode with all modulation types. All data rates for each modulation type have been tested, Only the data of worst case is recorded in the report.
Final test	10	TX mode (U-NII-2A) _Keep the EUT in continuously transmitting mode with all modulation types. All data rates for each modulation type have been tested, Only the data of worst case is recorded in the report.
Final test	11	TX mode (U-NII-2C) _Keep the EUT in continuously transmitting mode with all modulation types. All data rates for each modulation type have been tested, Only the data of worst case is recorded in the report.
Final test	12	TX mode (U-NII-3) _Keep the EUT in continuously transmitting mode with all modulation types. All data rates for each modulation type have been tested, Only the data of worst case is recorded in the report.

7.7.3 Test Setup Diagram

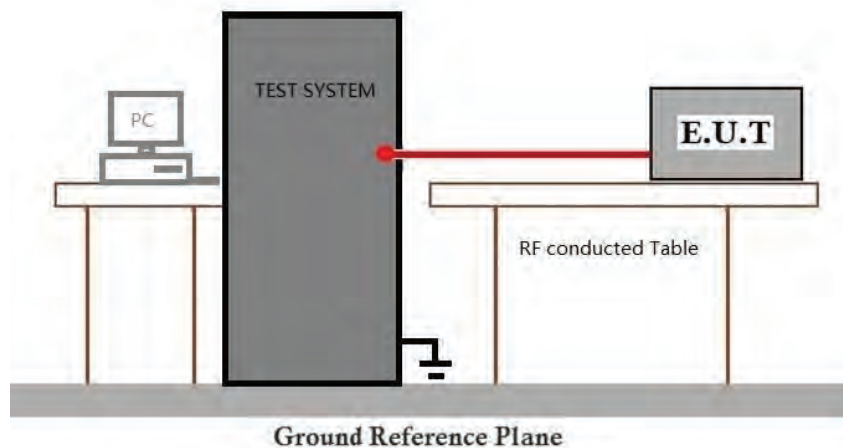

7.7.4 Measurement Procedure and Data

Please Refer to Appendix for Details



Unless otherwise agreed in writing, this document is issued by the Company subject to its General Conditions of Service printed overleaf, available on request or accessible at <https://www.sgs.com/en/Terms-and-Conditions>. Attention is drawn to the limitation of liability, indemnification and jurisdiction issues defined therein. Any holder of this document is advised that information contained hereon reflects the Company's findings at the time of its intervention only and within the limits of Client's instructions, if any. The Company's sole responsibility is to its Client and this document does not exonerate parties to a transaction from exercising all their rights and obligations under the transaction documents. This document cannot be reproduced except in full, without prior written approval of the Company. Any unauthorized alteration, forgery or falsification of the content or appearance of this document is unlawful and offenders may be prosecuted to the fullest extent of the law. Unless otherwise stated the results shown in this test report refer only to the sample(s) tested and such sample(s) are retained for 30 days only.
Attention: To check the authenticity of testing /inspection report & certificate, please contact us at telephone: (86-755) 8307 1443, or email: CN.Doccheck@sgs.com
 No.1 Workshop, M-10, Middle Section, Science & Technology Park, Nanshan District, Shenzhen, Guangdong, China 518057 t (86-755) 26012053 f (86-755) 26710594 www.sgs.com.cn
 中国·广东·深圳市南山区科技园中区M-10栋1号厂房 邮编: 518057 t (86-755) 26012053 f (86-755) 26710594 sgs.china@sgs.com

7.8 99% Bandwidth

Test Requirement ANSI C63.10 (2013) Section 12.4.2
 Test Method: ANSI C63.10 (2013) Section 12.4.2

7.8.1 E.U.T. Operation

Operating Environment:
 Temperature: 25.1 °C Humidity: 40.2 % RH Atmospheric Pressure: 1020 mbar

7.8.2 Test Mode Description

Pre-scan / Final test	Mode Code	Description
Final test	09	TX mode (U-NII-1)_Keep the EUT in continuously transmitting mode with all modulation types. All data rates for each modulation type have been tested, Only the data of worst case is recorded in the report.
Final test	10	TX mode (U-NII-2A) _Keep the EUT in continuously transmitting mode with all modulation types. All data rates for each modulation type have been tested, Only the data of worst case is recorded in the report.
Final test	11	TX mode (U-NII-2C) _Keep the EUT in continuously transmitting mode with all modulation types. All data rates for each modulation type have been tested, Only the data of worst case is recorded in the report.
Final test	12	TX mode (U-NII-3) _Keep the EUT in continuously transmitting mode with all modulation types. All data rates for each modulation type have been tested, Only the data of worst case is recorded in the report.

7.8.3 Test Setup Diagram

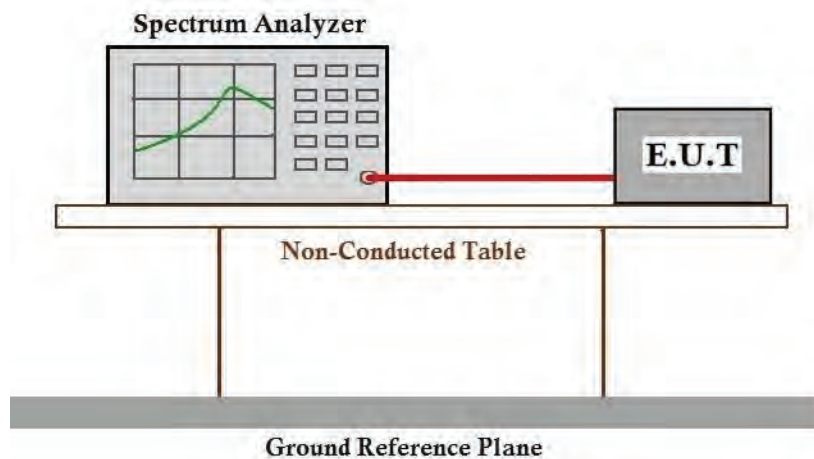

7.8.4 Measurement Procedure and Data

Please Refer to Appendix for Details



Unless otherwise agreed in writing, this document is issued by the Company subject to its General Conditions of Service printed overleaf, available on request or accessible at <https://www.sgs.com/en/Terms-and-Conditions>. Attention is drawn to the limitation of liability, indemnification and jurisdiction issues defined therein. Any holder of this document is advised that information contained hereon reflects the Company's findings at the time of its intervention only and within the limits of Client's instructions, if any. The Company's sole responsibility is to its Client and this document does not exonerate parties to a transaction from exercising all their rights and obligations under the transaction documents. This document cannot be reproduced except in full, without prior written approval of the Company. Any unauthorized alteration, forgery or falsification of the content or appearance of this document is unlawful and offenders may be prosecuted to the fullest extent of the law. Unless otherwise stated the results shown in this test report refer only to the sample(s) tested and such sample(s) are retained for 30 days only.
Attention: To check the authenticity of testing /inspection report & certificate, please contact us at telephone: (86-755) 8307 1443, or email: CN.Doccheck@sgs.com
 No.1 Workshop, M-10, Middle Section, Science & Technology Park, Nanshan District, Shenzhen, Guangdong, China 518057 t (86-755) 26012053 f (86-755) 26710594 www.sgsgroup.com.cn
 中国·广东·深圳市南山区科技园中区M-10栋1号厂房 邮编: 518057 t (86-755) 26012053 f (86-755) 26710594 sgs.china@sgs.com

7.9 26dB Emission bandwidth

Test Requirement 47 CFR Part 15, Subpart E 15.407 (a)
 Test Method: ANSI C63.10 (2013) Section 12.4.1

7.9.1 E.U.T. Operation

Operating Environment:
 Temperature: 25.1 °C Humidity: 40.2 % RH Atmospheric Pressure: 1020 mbar

7.9.2 Test Mode Description

Pre-scan / Final test	Mode Code	Description
Final test	09	TX mode (U-NII-1)_Keep the EUT in continuously transmitting mode with all modulation types. All data rates for each modulation type have been tested, Only the data of worst case is recorded in the report.
Final test	10	TX mode (U-NII-2A) _Keep the EUT in continuously transmitting mode with all modulation types. All data rates for each modulation type have been tested, Only the data of worst case is recorded in the report.
Final test	11	TX mode (U-NII-2C) _Keep the EUT in continuously transmitting mode with all modulation types. All data rates for each modulation type have been tested, Only the data of worst case is recorded in the report.

7.9.3 Test Setup Diagram

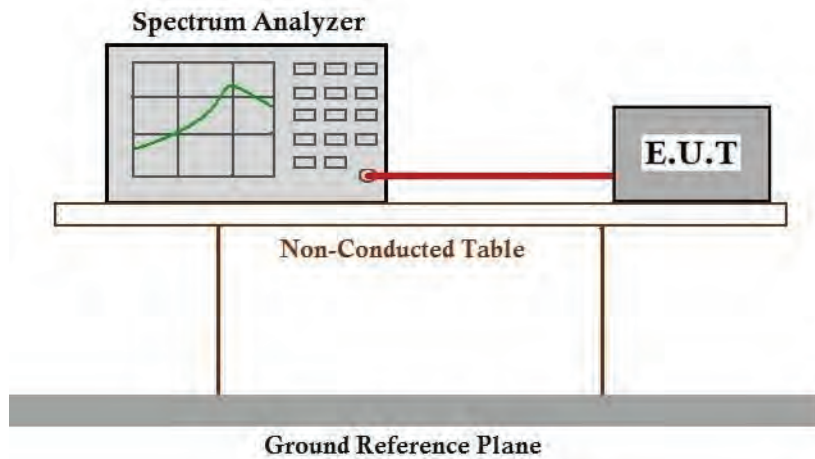

7.9.4 Measurement Procedure and Data

Please Refer to Appendix for Details



Unless otherwise agreed in writing, this document is issued by the Company subject to its General Conditions of Service printed overleaf, available on request or accessible at <https://www.sgs.com/en/Terms-and-Conditions>. Attention is drawn to the limitation of liability, indemnification and jurisdiction issues defined therein. Any holder of this document is advised that information contained hereon reflects the Company's findings at the time of its intervention only and within the limits of Client's instructions, if any. The Company's sole responsibility is to its Client and this document does not exonerate parties to a transaction from exercising all their rights and obligations under the transaction documents. This document cannot be reproduced except in full, without prior written approval of the Company. Any unauthorized alteration, forgery or falsification of the content or appearance of this document is unlawful and offenders may be prosecuted to the fullest extent of the law. Unless otherwise stated the results shown in this test report refer only to the sample(s) tested and such sample(s) are retained for 30 days only.

Attention: To check the authenticity of testing /inspection report & certificate, please contact us at telephone: (86-755) 8307 1443, or email: CN.Doccheck@sgs.com
 No.1 Workshop, M-10, Middle Section, Science & Technology Park, Nanshan District, Shenzhen, Guangdong, China 518057 t (86-755) 26012053 f (86-755) 26710594 www.sgs.com.cn
 中国·广东·深圳市南山区科技园中区M-10栋1号厂房 邮编: 518057 t (86-755) 26012053 f (86-755) 26710594 sgs.china@sgs.com

7.10 Minimum 6 dB bandwidth (5.725-5.85 GHz band)

Test Requirement 47 CFR Part 15, Subpart E 15.407 (e)

Test Method: ANSI C63.10 (2013) Section 6.9.2

Limit:

Frequency band(MHz)	Limit
5725-5850	≥500 kHz

7.10.1 E.U.T. Operation

Operating Environment:

Temperature: 25.1 °C Humidity: 40.2 % RH Atmospheric Pressure: 1020 mbar

7.10.2 Test Mode Description

Pre-scan / Final test	Mode Code	Description
Final test	12	TX mode (U-NII-3) _Keep the EUT in continuously transmitting mode with all modulation types. All data rates for each modulation type have been tested, Only the data of worst case is recorded in the report.

7.10.3 Test Setup Diagram

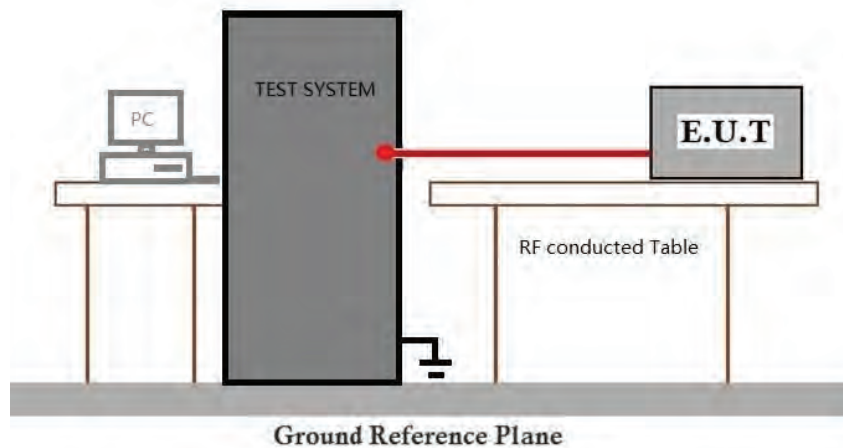

7.10.4 Measurement Procedure and Data

Please Refer to Appendix for Details



7.11 Peak Power spectrum density

Test Requirement 47 CFR Part 15, Subpart E 15.407 (a)

Test Method: ANSI C63.10 (2013) Section 12.5

Limit:

Frequency band(MHz)	Limit
5150-5250	≤17dBm in 1MHz for master device
	≤11dBm in 1MHz for client device
5250-5350	≤11dBm in 1MHz for client device
5470-5725	≤11dBm in 1MHz for client device
5725-5850	≤30dBm in 500 kHz
Remark:	The maximum power spectral density is measured as a conducted emission by direct connection of a calibrated test instrument to the equipment under test.

7.11.1 E.U.T. Operation

Operating Environment:

Temperature: 25.1 °C Humidity: 40.2 % RH Atmospheric Pressure: 1020 mbar

7.11.2 Test Mode Description

Pre-scan / Final test	Mode Code	Description
Final test	09	TX mode (U-NII-1)_Keep the EUT in continuously transmitting mode with all modulation types. All data rates for each modulation type have been tested, Only the data of worst case is recorded in the report.
Final test	10	TX mode (U-NII-2A)_Keep the EUT in continuously transmitting mode with all modulation types. All data rates for each modulation type have been tested, Only the data of worst case is recorded in the report.
Final test	11	TX mode (U-NII-2C)_Keep the EUT in continuously transmitting mode with all modulation types. All data rates for each modulation type have been tested, Only the data of worst case is recorded in the report.
Final test	12	TX mode (U-NII-3)_Keep the EUT in continuously transmitting mode with all modulation types. All data rates for each modulation type have been tested, Only the data of worst case is recorded in the report.



Unless otherwise agreed in writing, this document is issued by the Company subject to its General Conditions of Service printed overleaf, available on request or accessible at <https://www.sgs.com/en/Terms-and-Conditions>. Attention is drawn to the limitation of liability, indemnification and jurisdiction issues defined therein. Any holder of this document is advised that information contained hereon reflects the Company's findings at the time of its intervention only and within the limits of Client's instructions, if any. The Company's sole responsibility is to its Client and this document does not exonerate parties to a transaction from exercising all their rights and obligations under the transaction documents. This document cannot be reproduced except in full, without prior written approval of the Company. Any unauthorized alteration, forgery or falsification of the content or appearance of this document is unlawful and offenders may be prosecuted to the fullest extent of the law. Unless otherwise stated the results shown in this test report refer only to the sample(s) tested and such sample(s) are retained for 30 days only.

Attention: To check the authenticity of testing /inspection report & certificate, please contact us at telephone: (86-755) 8307 1443, or email: CN.Doccheck@sgs.com

7.11.3 Test Setup Diagram

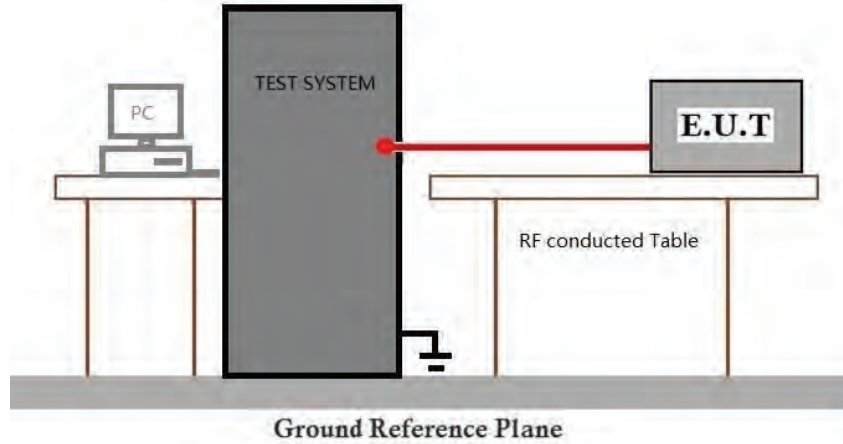

7.11.4 Measurement Procedure and Data

RBW conversion factor from 300kHz to 500kHz (2.22dB) for UNII Band 3 has been considered.

Please Refer to Appendix for Details



7.12 Frequency Stability

Test Requirement 47 CFR Part 15, Subpart E 15.407 (g)
 Test Method: ANSI C63.10 (2013) Section 6.8

7.12.1 E.U.T. Operation

Operating Environment:
 Temperature: 25.1 °C Humidity: 40.2 % RH Atmospheric Pressure: 1020 mbar

7.12.2 Test Mode Description

Pre-scan / Final test	Mode Code	Description
Final test	09	TX mode (U-NII-1)_Keep the EUT in continuously transmitting mode with all modulation types. All data rates for each modulation type have been tested, Only the data of worst case is recorded in the report.
Final test	10	TX mode (U-NII-2A) _Keep the EUT in continuously transmitting mode with all modulation types. All data rates for each modulation type have been tested, Only the data of worst case is recorded in the report.
Final test	11	TX mode (U-NII-2C) _Keep the EUT in continuously transmitting mode with all modulation types. All data rates for each modulation type have been tested, Only the data of worst case is recorded in the report.
Final test	12	TX mode (U-NII-3) _Keep the EUT in continuously transmitting mode with all modulation types. All data rates for each modulation type have been tested, Only the data of worst case is recorded in the report.

7.12.3 Test Setup Diagram

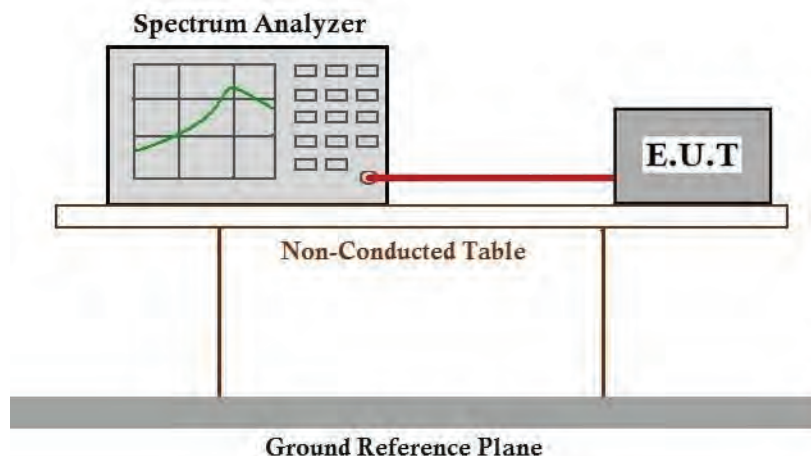

7.12.4 Measurement Procedure and Data

Please Refer to Appendix for Details



Unless otherwise agreed in writing, this document is issued by the Company subject to its General Conditions of Service printed overleaf, available on request or accessible at <https://www.sgs.com/en/Terms-and-Conditions>. Attention is drawn to the limitation of liability, indemnification and jurisdiction issues defined therein. Any holder of this document is advised that information contained hereon reflects the Company's findings at the time of its intervention only and within the limits of Client's instructions, if any. The Company's sole responsibility is to its Client and this document does not exonerate parties to a transaction from exercising all their rights and obligations under the transaction documents. This document cannot be reproduced except in full, without prior written approval of the Company. Any unauthorized alteration, forgery or falsification of the content or appearance of this document is unlawful and offenders may be prosecuted to the fullest extent of the law. Unless otherwise stated the results shown in this test report refer only to the sample(s) tested and such sample(s) are retained for 30 days only.
Attention: To check the authenticity of testing /inspection report & certificate, please contact us at telephone: (86-755) 8307 1443, or email: CN.Doccheck@sgs.com
 No.1 Workshop, M-10, Middle Section, Science & Technology Park, Nanshan District, Shenzhen, Guangdong, China 518057 t (86-755) 26012053 f (86-755) 26710594 www.sgsgroup.com.cn
 中国·广东·深圳市南山区科技园中区M-10栋1号厂房 邮编: 518057 t (86-755) 26012053 f (86-755) 26710594 sgs.china@sgs.com

7.13 Non-occupancy period

Test Requirement KDB 905462 D02 Section 5.1
 Test Method: KDB 905462 D02 Section 7.8.3

Limit:

Test item	Limit	Applicability	
		Master Device or client with Radar Detection	Client without Radar Detection
Non-occupancy period	Minimum 30 minutes	Yes	Not required
Channel Availability Check Time	60 seconds	Yes	Not required
Channel Move Time	10 seconds See Note 1.	Yes	Yes
Channel Closing Transmission Time	200 milliseconds + an aggregate of 60 milliseconds over remaining 10 second period. See Notes 1 and 2.	Yes	Yes
U-NII Detection Bandwidth	Minimum 100% of the U-NII 99% transmission power bandwidth. See Note 3.	Yes	Not required

Note 1: Channel Move Time and the Channel Closing Transmission Time should be performed with Radar Type 0. The measurement timing begins at the end of the Radar Type 0 burst.

Note 2: The Channel Closing Transmission Time is comprised of 200 milliseconds starting at the beginning of the Channel Move Time plus any additional intermittent control signals required to facilitate a Channel move (an aggregate of 60 milliseconds) during the remainder of the 10 second period. The aggregate duration of control signals will not count quiet periods in between transmissions.

Note 3: During the U-NII Detection Bandwidth detection test, radar type 0 should be used. For each frequency step the minimum percentage of detection is 90 percent. Measurements are performed with no data traffic.

7.13.1 E.U.T. Operation

Operating Environment:

Temperature: 25.6 °C Humidity: 41.0 % RH Atmospheric Pressure: 1020 mbar



Unless otherwise agreed in writing, this document is issued by the Company subject to its General Conditions of Service printed overleaf, available on request or accessible at <https://www.sgs.com/en/Terms-and-Conditions>. Attention is drawn to the limitation of liability, indemnification and jurisdiction issues defined therein. Any holder of this document is advised that information contained hereon reflects the Company's findings at the time of its intervention only and within the limits of Client's instructions, if any. The Company's sole responsibility is to its Client and this document does not exonerate parties to a transaction from exercising all their rights and obligations under the transaction documents. This document cannot be reproduced except in full, without prior written approval of the Company. Any unauthorized alteration, forgery or falsification of the content or appearance of this document is unlawful and offenders may be prosecuted to the fullest extent of the law. Unless otherwise stated the results shown in this test report refer only to the sample(s) tested and such sample(s) are retained for 30 days only.

Attention: To check the authenticity of testing /inspection report & certificate, please contact us at telephone: (86-755) 8307 1443, or email: CN.Doccheck@sgs.com
 No.1 Workshop, M-10, Middle Section, Science & Technology Park, Nanshan District, Shenzhen, Guangdong, China 518057 t (86-755) 26012053 f (86-755) 26710594 www.sgs.com.cn
 中国·广东·深圳市南山区科技园中区M-10栋1号厂房 邮编: 518057 t (86-755) 26012053 f (86-755) 26710594 sgs.china@sgs.com

7.13.2 Test Mode Description

Pre-scan / Final test	Mode Code	Description
Final test	13	Normal operating_Keep the EUT communication with the companion device.

7.13.3 Test Setup Diagram

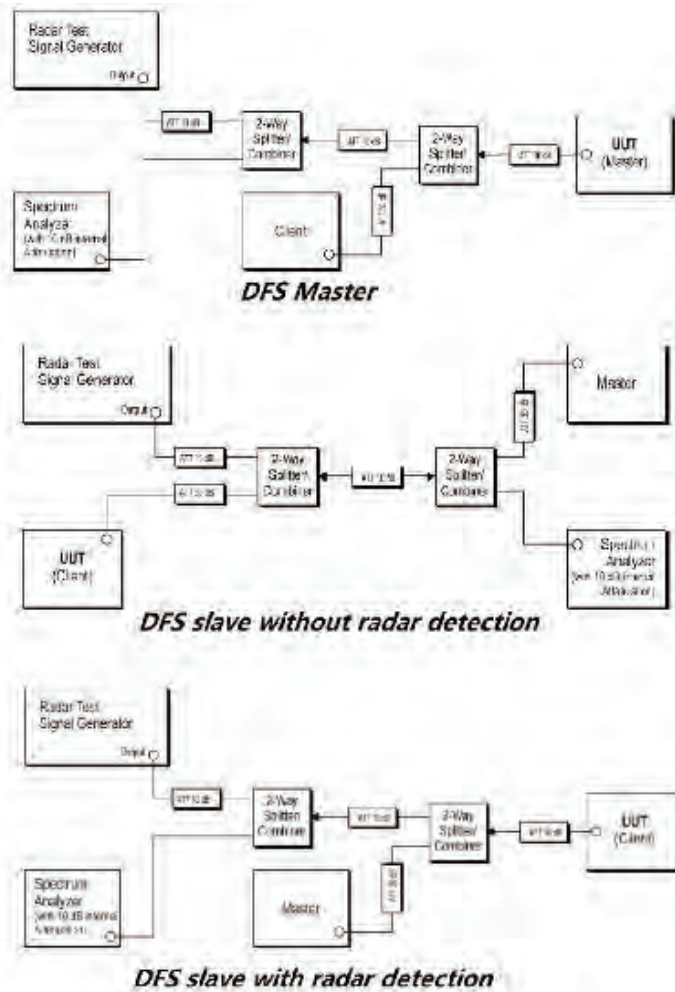

7.13.4 Measurement Procedure and Data

- 1) The radar pulse generator is setup to provide a pulse at frequency that the master and client are operating. A type 0 radar pulse with a 1us pulse width and a 1428us PRI is used for the testing.
- 2) The vector signal generator is adjusted to provide the radar burst (18 pulses) at the level of approximately -61dBm at the antenna port of the master device.
- 3) A trigger is provided from the pulse generator to the DFS monitoring system in order to capture the traffic and the occurrence of the radar pulse.
- 4) EUT will associate with the master at channel. The file "iperf.exe" specified by the FCC is streamed from the PC 2 through the master and the client device to the PC 1 and played in full motion video using Media Player Classic Ver. 6.4.8.6 in order to properly load the network for the entire period of the test.
- 5) When radar burst with a level equal to the DFS Detection Threshold +1dB is generated on the operating channel of the U-NII device. At time T0 the radar waveform generator sends a burst of pulse of the radar waveform at Detection Threshold +1dB.
- 6) Observe the transmissions of the EUT at the end of the radar Burst on the Operating Channel. Measure and record the transmissions from the UUT during the observation time (Channel Move Time). One 15 seconds plot is reported for the Short Pulse Radar Type 0. The plot for the Short Pulse Radar Types start at the end of the radar burst. The Channel Move Time will be calculated based on the zoom in 600ms plot of the Short Pulse Radar Type.
- 7) Measurement of the aggregate duration of the Channel Closed Transmission Time method. With the spectrum analyzer set to zero span tuned to the center frequency of the EUT operating channel at the radar simulated frequency, peak detection, and max hold, the dwell time per bin is given by: $Dwell (0.3ms) = S (3.8300ms) / B (4000)$; where Dwell is the dwell time per spectrum analyzer sampling bin, S is sweep time and B is the number of spectrum analyzer sampling bins. An upper bound of the aggregate duration of the intermittent control signals of Channel Closing Transmission Time is calculated by: $C (ms) = N \times Dwell (0.3ms)$; where C is the Closing Time, N is the number of spectrum analyzer sampling bins (intermittent control signals) showing a U-NII transmission and Dwell is the dwell time per bin.
- 8) Measurement the EUT for more than 30 minutes following the channel move time to verify that no transmission or beacons occur on this channel.

Please Refer to Appendix for Details



Unless otherwise agreed in writing, this document is issued by the Company subject to its General Conditions of Service printed overleaf, available on request or accessible at <https://www.sgs.com/en/Terms-and-Conditions>. Attention is drawn to the limitation of liability, indemnification and jurisdiction issues defined therein. Any holder of this document is advised that information contained hereon reflects the Company's findings at the time of its intervention only and within the limits of Client's instructions, if any. The Company's sole responsibility is to its Client and this document does not exonerate parties to a transaction from exercising all their rights and obligations under the transaction documents. This document cannot be reproduced except in full, without prior written approval of the Company. Any unauthorized alteration, forgery or falsification of the content or appearance of this document is unlawful and offenders may be prosecuted to the fullest extent of the law. Unless otherwise stated the results shown in this test report refer only to the sample(s) tested and such sample(s) are retained for 30 days only.

Attention: To check the authenticity of testing /inspection report & certificate, please contact us at telephone: (86-755) 8307 1443, or email: CN.Doccheck@sgs.com

7.14 Channel Closing Transmission Time

Test Requirement KDB 905462 D02 Section 5.1
 Test Method: KDB 905462 D02 Section 7.8.3

Limit:

Test item	Limit	Applicability	
		Master Device or client with Radar Detection	Client without Radar Detection
Non-occupancy period	Minimum 30 minutes	Yes	Not required
Channel Availability Check Time	60 seconds	Yes	Not required
Channel Move Time	10 seconds See Note 1.	Yes	Yes
Channel Closing Transmission Time	200 milliseconds + an aggregate of 60 milliseconds over remaining 10 second period. See Notes 1 and 2.	Yes	Yes
U-NII Detection Bandwidth	Minimum 100% of the U-NII 99% transmission power bandwidth. See Note 3.	Yes	Not required

Note 1: Channel Move Time and the Channel Closing Transmission Time should be performed with Radar Type 0. The measurement timing begins at the end of the Radar Type 0 burst.

Note 2: The Channel Closing Transmission Time is comprised of 200 milliseconds starting at the beginning of the Channel Move Time plus any additional intermittent control signals required to facilitate a Channel move (an aggregate of 60 milliseconds) during the remainder of the 10 second period. The aggregate duration of control signals will not count quiet periods in between transmissions.

Note 3: During the U-NII Detection Bandwidth detection test, radar type 0 should be used. For each frequency step the minimum percentage of detection is 90 percent. Measurements are performed with no data traffic.

7.14.1 E.U.T. Operation

Operating Environment:

Temperature: 25.6 °C Humidity: 41.0 % RH Atmospheric Pressure: 1020 mbar



Unless otherwise agreed in writing, this document is issued by the Company subject to its General Conditions of Service printed overleaf, available on request or accessible at <https://www.sgs.com/en/Terms-and-Conditions>. Attention is drawn to the limitation of liability, indemnification and jurisdiction issues defined therein. Any holder of this document is advised that information contained hereon reflects the Company's findings at the time of its intervention only and within the limits of Client's instructions, if any. The Company's sole responsibility is to its Client and this document does not exonerate parties to a transaction from exercising all their rights and obligations under the transaction documents. This document cannot be reproduced except in full, without prior written approval of the Company. Any unauthorized alteration, forgery or falsification of the content or appearance of this document is unlawful and offenders may be prosecuted to the fullest extent of the law. Unless otherwise stated the results shown in this test report refer only to the sample(s) tested and such sample(s) are retained for 30 days only.

Attention: To check the authenticity of testing /inspection report & certificate, please contact us at telephone: (86-755) 8307 1443, or email: CN.Doccheck@sgs.com
 No.1 Workshop, M-10, Middle Section, Science & Technology Park, Nanshan District, Shenzhen, Guangdong, China 518057 t (86-755) 26012053 f (86-755) 26710594 www.sgs.com.cn
 中国·广东·深圳市南山区科技园中区M-10栋1号厂房 邮编: 518057 t (86-755) 26012053 f (86-755) 26710594 sgs.china@sgs.com

7.14.2 Test Mode Description

Pre-scan / Final test	Mode Code	Description
Final test	13	Normal operating_Keep the EUT communication with the companion device.

7.14.3 Test Setup Diagram

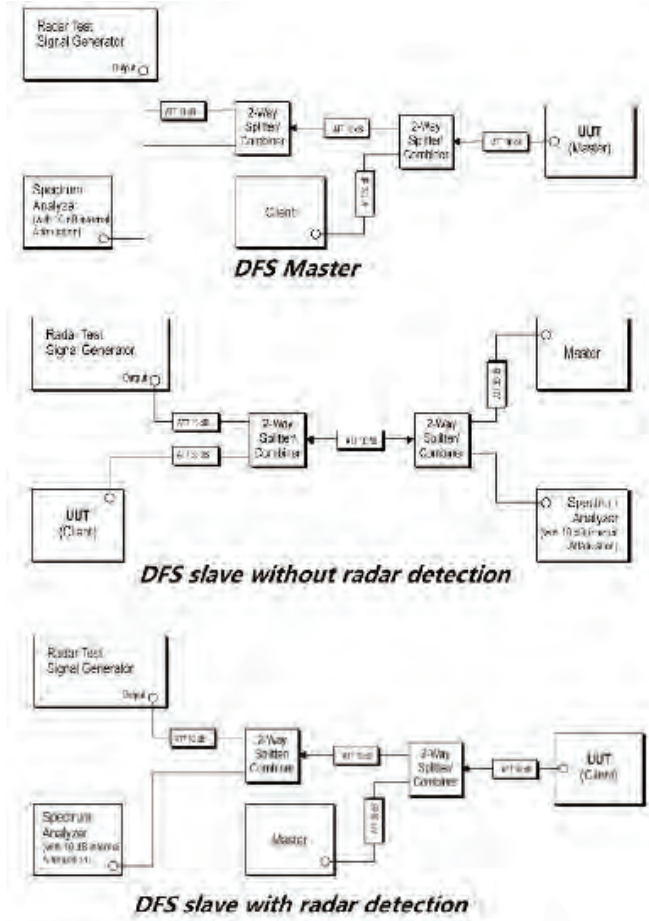

7.14.4 Measurement Procedure and Data

- 1) The radar pulse generator is setup to provide a pulse at frequency that the master and client are operating. A type 0 radar pulse with a 1us pulse width and a 1428us PRI is used for the testing.
- 2) The vector signal generator is adjusted to provide the radar burst (18 pulses) at the level of approximately -61dBm at the antenna port of the master device.
- 3) A trigger is provided from the pulse generator to the DFS monitoring system in order to capture the traffic and the occurrence of the radar pulse.
- 4) EUT will associate with the master at channel. The file "iperf.exe" specified by the FCC is streamed from the PC 2 through the master and the client device to the PC 1 and played in full motion video using Media Player Classic Ver. 6.4.8.6 in order to properly load the network for the entire period of the test.
- 5) When radar burst with a level equal to the DFS Detection Threshold +1dB is generated on the operating channel of the U-NII device. At time T0 the radar waveform generator sends a burst of pulse of the radar waveform at Detection Threshold +1dB.
- 6) Observe the transmissions of the EUT at the end of the radar Burst on the Operating Channel. Measure and record the transmissions from the UUT during the observation time (Channel Move Time). One 15 seconds plot is reported for the Short Pulse Radar Type 0. The plot for the Short Pulse Radar Types start at the end of the radar burst. The Channel Move Time will be calculated based on the zoom in 600ms plot of the Short Pulse Radar Type.
- 7) Measurement of the aggregate duration of the Channel Closed Transmission Time method. With the spectrum analyzer set to zero span tuned to the center frequency of the EUT operating channel at the radar simulated frequency, peak detection, and max hold, the dwell time per bin is given by: $Dwell (0.3ms) = S (3.8300ms) / B (4000)$; where Dwell is the dwell time per spectrum analyzer sampling bin, S is sweep time and B is the number of spectrum analyzer sampling bins. An upper bound of the aggregate duration of the intermittent control signals of Channel Closing Transmission Time is calculated by: $C (ms) = N \times Dwell (0.3ms)$; where C is the Closing Time, N is the number of spectrum analyzer sampling bins (intermittent control signals) showing a U-NII transmission and Dwell is the dwell time per bin.
- 8) Measurement the EUT for more than 30 minutes following the channel move time to verify that no transmission or beacons occur on this channel.

Please Refer to Appendix for Details



Unless otherwise agreed in writing, this document is issued by the Company subject to its General Conditions of Service printed overleaf, available on request or accessible at <https://www.sgs.com/en/Terms-and-Conditions>. Attention is drawn to the limitation of liability, indemnification and jurisdiction issues defined therein. Any holder of this document is advised that information contained hereon reflects the Company's findings at the time of its intervention only and within the limits of Client's instructions, if any. The Company's sole responsibility is to its Client and this document does not exonerate parties to a transaction from exercising all their rights and obligations under the transaction documents. This document cannot be reproduced except in full, without prior written approval of the Company. Any unauthorized alteration, forgery or falsification of the content or appearance of this document is unlawful and offenders may be prosecuted to the fullest extent of the law. Unless otherwise stated the results shown in this test report refer only to the sample(s) tested and such sample(s) are retained for 30 days only.

Attention: To check the authenticity of testing /inspection report & certificate, please contact us at telephone: (86-755) 8307 1443, or email: CN.Doccheck@sgs.com
 No.1 Workshop, M-10, Middle Section, Science & Technology Park, Nanshan District, Shenzhen, Guangdong, China 518057 t (86-755) 26012053 f (86-755) 26710594 www.sgs.com.cn
 中国·广东·深圳市南山区科技园中区M-10栋1号厂房 邮编: 518057 t (86-755) 26012053 f (86-755) 26710594 sgs.china@sgs.com

8 Test Setup Photo

Please refer to SZCR2504001607 Appendix_Setup Photo

9 EUT Constructional Details (EUT Photos)

Refer to Appendix - Photographs of EUT Constructional Details for SZCR2504001607WM



Unless otherwise agreed in writing, this document is issued by the Company subject to its General Conditions of Service printed overleaf, available on request or accessible at <https://www.sgs.com/en/Terms-and-Conditions>. Attention is drawn to the limitation of liability, indemnification and jurisdiction issues defined therein. Any holder of this document is advised that information contained hereon reflects the Company's findings at the time of its intervention only and within the limits of Client's instructions, if any. The Company's sole responsibility is to its Client and this document does not exonerate parties to a transaction from exercising all their rights and obligations under the transaction documents. This document cannot be reproduced except in full, without prior written approval of the Company. Any unauthorized alteration, forgery or falsification of the content or appearance of this document is unlawful and offenders may be prosecuted to the fullest extent of the law. Unless otherwise stated the results shown in this test report refer only to the sample(s) tested and such sample(s) are retained for 30 days only.

Attention: To check the authenticity of testing /inspection report & certificate, please contact us at telephone: (86-755) 8307 1443, or email: CN.Doccheck@sgs.com

10 Appendix

1. Duty Cycle

1.1 Test Result

1.1.1 Ant9

Ant9									
Mode	TX Type	Frequency (MHz)	RU	RU Pos	T_on (ms)	Period (ms)	Duty Cycle (%)	Duty Cycle Correction Factor (dB)	Max. DC Variation (%)
802.11a	MIMO	5180	/	/	2.097	2.114	99.20	0.04	0.03
		5200	/	/	2.098	2.113	99.29	0.03	0.00
		5240	/	/	2.097	2.113	99.24	0.03	0.03
		5260	/	/	2.098	2.114	99.24	0.03	0.00
		5300	/	/	2.098	2.114	99.24	0.03	0.00
		5320	/	/	2.098	2.114	99.24	0.03	0.03
		5500	/	/	2.097	2.114	99.20	0.04	0.03
		5580	/	/	2.097	2.114	99.20	0.04	0.03
		5700	/	/	2.097	2.114	99.20	0.04	0.03
		5745	/	/	2.098	2.114	99.24	0.03	0.03
		5785	/	/	2.098	2.114	99.24	0.03	0.00
5825	/	/	2.098	2.114	99.24	0.03	0.03	0.00	
802.11n (HT20)	MIMO	5180	/	/	1.818	1.834	99.13	0.04	0.03
		5200	/	/	0.574	0.590	97.29	0.12	0.07
		5240	/	/	5.330	5.346	99.70	0.01	0.04
		5260	/	/	5.329	5.346	99.68	0.01	0.03
		5300	/	/	5.330	5.346	99.70	0.01	0.03
		5320	/	/	1.818	1.833	99.18	0.04	0.03
		5500	/	/	5.330	5.346	99.70	0.01	0.04
		5580	/	/	2.725	2.741	99.42	0.03	0.03
		5700	/	/	5.329	5.346	99.68	0.01	0.03
		5745	/	/	5.330	5.346	99.70	0.01	0.03
		5785	/	/	5.330	5.345	99.72	0.01	0.00
5825	/	/	4.878	4.895	99.65	0.02	0.04		
802.11n (HT40)	MIMO	5190	/	/	1.217	1.233	98.70	0.06	0.04
		5230	/	/	1.713	1.729	99.07	0.04	0.03
		5270	/	/	5.412	5.428	99.71	0.01	0.04



Unless otherwise agreed in writing, this document is issued by the Company subject to its General Conditions of Service printed overleaf, available on request or accessible at <https://www.sgs.com/en/Terms-and-Conditions>. Attention is drawn to the limitation of liability, indemnification and jurisdiction issues defined therein. Any holder of this document is advised that information contained hereon reflects the Company's findings at the time of its intervention only and within the limits of Client's instructions, if any. The Company's sole responsibility is to its Client and this document does not exonerate parties to a transaction from exercising all their rights and obligations under the transaction documents. This document cannot be reproduced except in full, without prior written approval of the Company. Any unauthorized alteration, forgery or falsification of the content or appearance of this document is unlawful and offenders may be prosecuted to the fullest extent of the law. Unless otherwise stated the results shown in this test report refer only to the sample(s) tested and such sample(s) are retained for 30 days only.

Attention: To check the authenticity of testing /inspection report & certificate, please contact us at telephone: (86-755) 8307 1443, or email: CN.Doccheck@sgs.com

		5310	/	/	5.412	5.428	99.71	0.01	0.04
		5510	/	/	5.412	5.428	99.71	0.01	0.04
		5550	/	/	5.412	5.428	99.71	0.01	0.04
		5670	/	/	3.778	3.794	99.58	0.02	0.03
		5755	/	/	5.412	5.428	99.71	0.01	0.04
		5795	/	/	1.641	1.657	99.03	0.04	0.04
802.11ac (VHT20)	MIMO	5180	/	/	2.389	2.405	99.33	0.03	0.04
		5200	/	/	5.334	5.350	99.70	0.01	0.04
		5240	/	/	5.333	5.350	99.68	0.01	0.03
		5260	/	/	4.201	4.218	99.60	0.02	0.04
		5300	/	/	5.332	5.348	99.70	0.01	0.04
		5320	/	/	5.334	5.350	99.70	0.01	0.04
		5500	/	/	5.334	5.350	99.70	0.01	0.04
		5580	/	/	2.728	2.745	99.38	0.03	0.03
		5700	/	/	5.332	5.350	99.66	0.01	0.04
		5745	/	/	5.333	5.350	99.68	0.01	0.03
		5785	/	/	5.334	5.350	99.70	0.01	0.04
		5825	/	/	5.333	5.350	99.68	0.01	0.03
802.11ac (VHT40)	MIMO	5190	/	/	1.929	1.945	99.18	0.04	0.03
		5230	/	/	5.417	5.434	99.69	0.01	0.03
		5270	/	/	5.417	5.434	99.69	0.01	0.03
		5310	/	/	1.929	1.945	99.18	0.04	0.00
		5510	/	/	3.922	3.937	99.62	0.02	0.00
		5550	/	/	3.564	3.581	99.53	0.02	0.04
		5670	/	/	2.641	2.657	99.40	0.03	0.04
		5755	/	/	0.865	0.881	98.18	0.08	0.07
802.11ac (VHT80)	MIMO	5210	/	/	3.028	3.044	99.47	0.02	0.04
		5290	/	/	1.217	1.233	98.70	0.06	0.03
		5530	/	/	4.289	4.306	99.61	0.02	0.04
		5610	/	/	0.613	0.628	97.61	0.10	0.03
		5775	/	/	5.397	5.414	99.69	0.01	0.03
802.11ac (VHT160)	MIMO	5570	/	/	1.172	1.188	98.65	0.06	0.03
		5250	/	/	2.921	2.937	99.46	0.02	0.03
802.11ax (HEW20)	MIMO	5180	RU242	Left	4.228	4.245	99.60	0.02	0.03
		5200	RU242	Left	3.888	3.904	99.59	0.02	0.03
		5240	RU242	Left	2.772	2.789	99.39	0.03	0.04
		5260	RU242	Left	2.175	2.190	99.32	0.03	0.00
		5300	RU242	Left	1.491	1.506	99.00	0.04	0.03
		5320	RU242	Left	5.253	5.272	99.64	0.02	0.07



Unless otherwise agreed in writing, this document is issued by the Company subject to its General Conditions of Service printed overleaf, available on request or accessible at <https://www.sgs.com/en/Terms-and-Conditions>. Attention is drawn to the limitation of liability, indemnification and jurisdiction issues defined therein. Any holder of this document is advised that information contained hereon reflects the Company's findings at the time of its intervention only and within the limits of Client's instructions, if any. The Company's sole responsibility is to its Client and this document does not exonerate parties to a transaction from exercising all their rights and obligations under the transaction documents. This document cannot be reproduced except in full, without prior written approval of the Company. Any unauthorized alteration, forgery or falsification of the content or appearance of this document is unlawful and offenders may be prosecuted to the fullest extent of the law. Unless otherwise stated the results shown in this test report refer only to the sample(s) tested and such sample(s) are retained for 30 days only.

Attention: To check the authenticity of testing /inspection report & certificate, please contact us at telephone: (86-755) 8307 1443, or email: CN.Doccheck@sgs.com

SGS-CSTC Standards Technical Services Co., Ltd. Shenzhen Branch

SZEMC-TRF-01 Rev. A/1

Report No.: SZCR250400160706

Page: 245 of 556

		5500	RU242	Left	5.339	5.355	99.70	0.01	0.03
		5580	RU242	Left	5.338	5.354	99.70	0.01	0.04
		5700	RU242	Left	5.338	5.355	99.68	0.01	0.03
		5745	RU242	Left	5.338	5.354	99.70	0.01	0.04
		5785	RU242	Left	3.031	3.047	99.47	0.02	0.04
		5825	RU242	Left	5.338	5.355	99.68	0.01	0.03
802.11ax (HEW40)	MIMO	5190	RU484	Left	0.818	0.834	98.08	0.08	0.06
		5230	RU484	Left	1.543	1.558	99.04	0.04	0.03
		5270	RU484	Left	1.765	1.782	99.05	0.04	0.03
		5310	RU484	Left	2.156	2.172	99.26	0.03	0.03
		5510	RU484	Left	2.436	2.452	99.35	0.03	0.04
		5550	RU484	Left	5.390	5.407	99.69	0.01	0.03
		5670	RU484	Left	5.390	5.406	99.70	0.01	0.04
		5755	RU484	Left	5.390	5.406	99.70	0.01	0.04
802.11ax (HEW80)	MIMO	5795	RU484	Left	2.994	3.010	99.47	0.02	0.03
		5210	RU996	Left	3.221	3.237	99.51	0.02	0.03
		5290	RU996	Left	2.282	2.298	99.30	0.03	0.03
		5530	RU996	Left	5.264	5.279	99.72	0.01	0.00
		5610	RU996	Left	2.670	2.686	99.40	0.03	0.03
802.11ax (HEW160)	MIMO	5775	RU996	Left	5.264	5.280	99.70	0.01	0.04
		5570	2xRU996	Left	2.331	2.347	99.32	0.03	0.03
		5250	2xRU996	Left	4.353	4.369	99.63	0.02	0.04



Unless otherwise agreed in writing, this document is issued by the Company subject to its General Conditions of Service printed overleaf, available on request or accessible at <https://www.sgs.com/en/Terms-and-Conditions>. Attention is drawn to the limitation of liability, indemnification and jurisdiction issues defined therein. Any holder of this document is advised that information contained hereon reflects the Company's findings at the time of its intervention only and within the limits of Client's instructions, if any. The Company's sole responsibility is to its Client and this document does not exonerate parties to a transaction from exercising all their rights and obligations under the transaction documents. This document cannot be reproduced except in full, without prior written approval of the Company. Any unauthorized alteration, forgery or falsification of the content or appearance of this document is unlawful and offenders may be prosecuted to the fullest extent of the law. Unless otherwise stated the results shown in this test report refer only to the sample(s) tested and such sample(s) are retained for 30 days only.

Attention: To check the authenticity of testing /inspection report & certificate, please contact us at telephone: (86-755) 8307 1443, or email: CN.Doccheck@sgs.com

1.2 Test Graph

1.2.1 Ant9

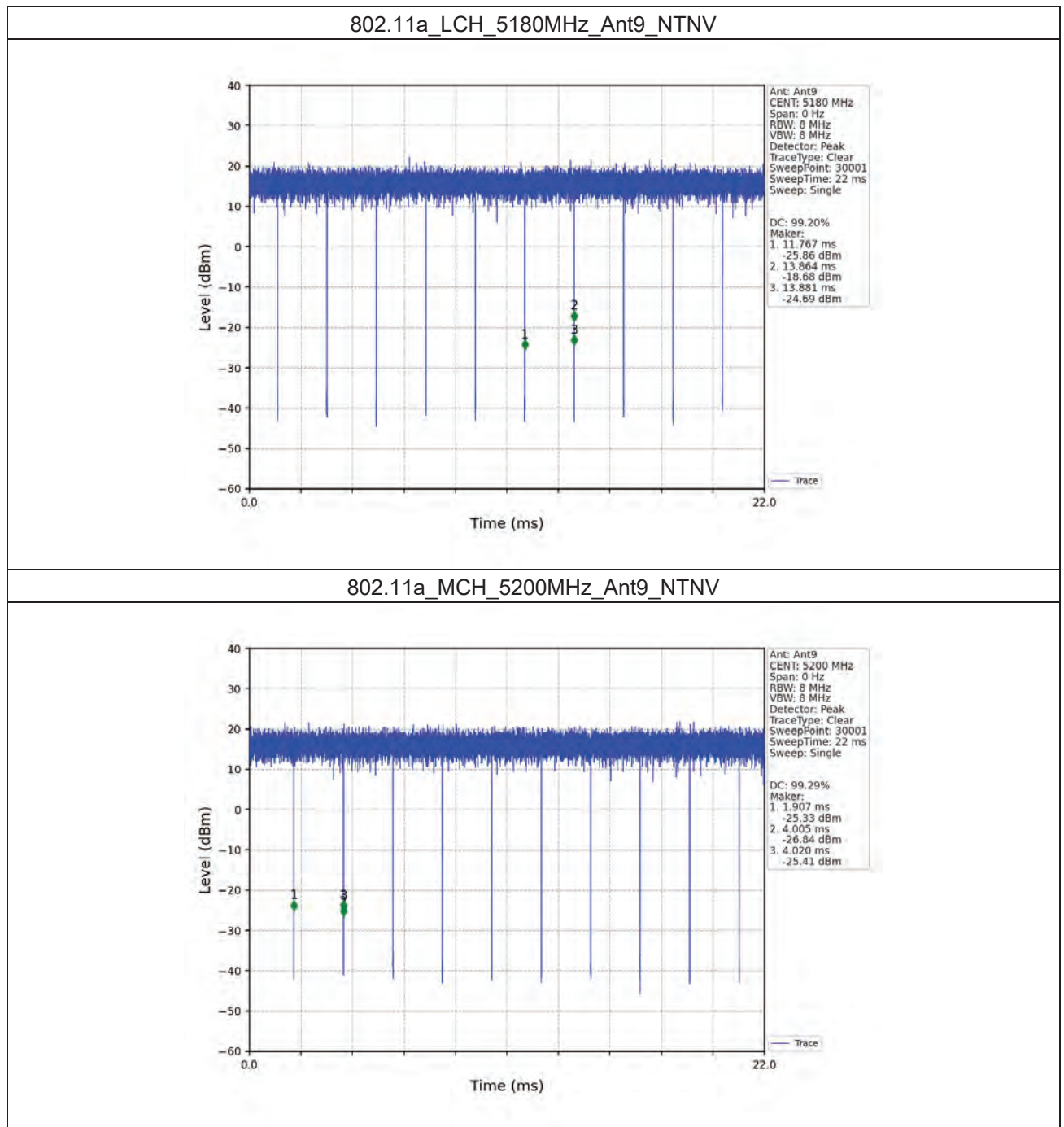

802.11a_HCH_5240MHz_Ant9_NTNV

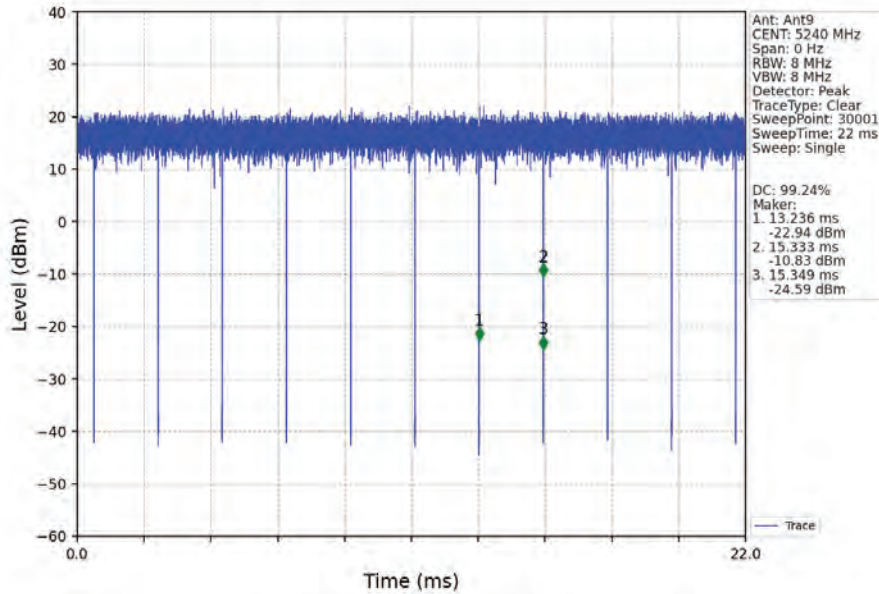

802.11a_LCH_5260MHz_Ant9_NTNV

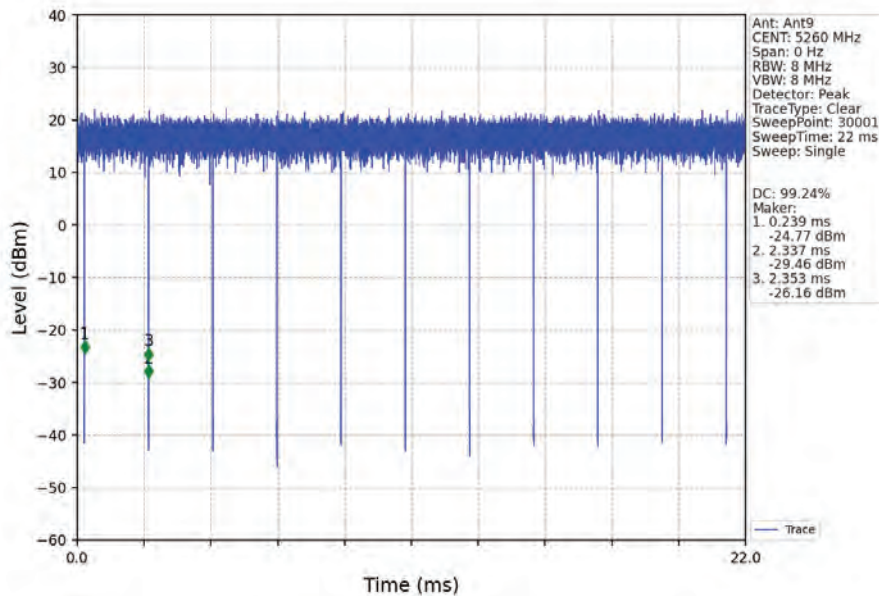

Unless otherwise agreed in writing, this document is issued by the Company subject to its General Conditions of Service printed overleaf, available on request or accessible at <https://www.sgs.com/en/Terms-and-Conditions>. Attention is drawn to the limitation of liability, indemnification and jurisdiction issues defined therein. Any holder of this document is advised that information contained hereon reflects the Company's findings at the time of its intervention only and within the limits of Client's instructions, if any. The Company's sole responsibility is to its Client and this document does not exonerate parties to a transaction from exercising all their rights and obligations under the transaction documents. This document cannot be reproduced except in full, without prior written approval of the Company. Any unauthorized alteration, forgery or falsification of the content or appearance of this document is unlawful and offenders may be prosecuted to the fullest extent of the law. Unless otherwise stated the results shown in this test report refer only to the sample(s) tested and such sample(s) are retained for 30 days only.

Attention: To check the authenticity of testing /inspection report & certificate, please contact us at telephone: (86-755) 8307 1443, or email: CN.Doccheck@sgs.com

802.11a_MCH_5300MHz_Ant9_NTNV

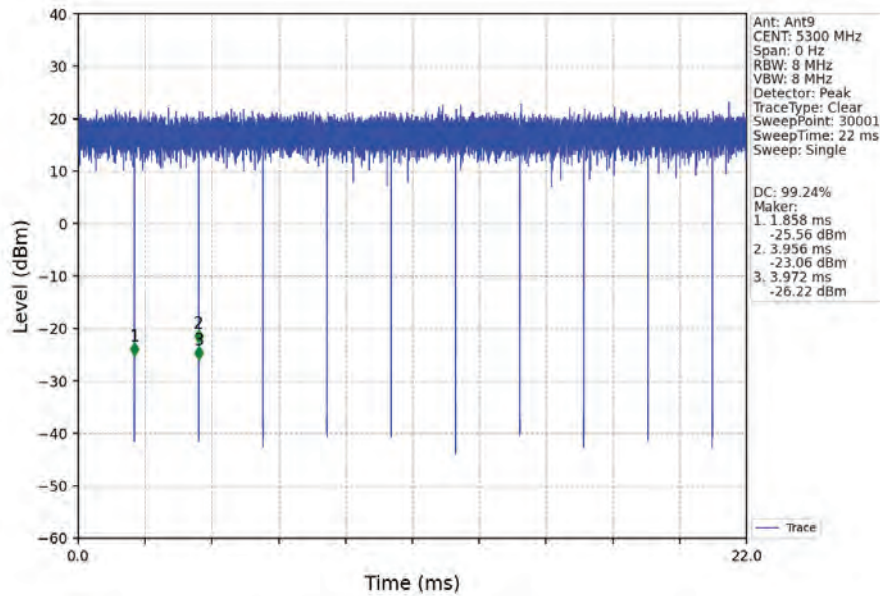

802.11a_HCH_5320MHz_Ant9_NTNV

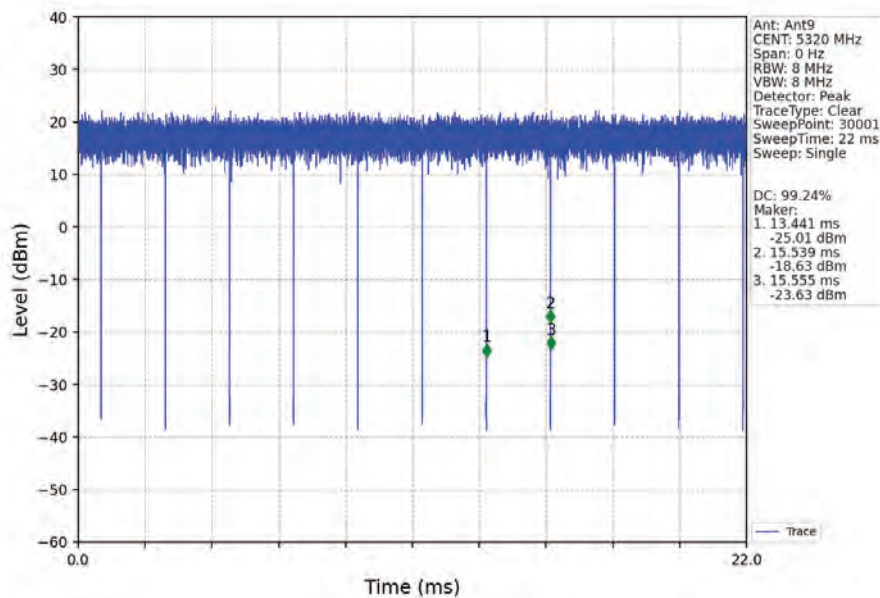

802.11a_LCH_5500MHz_Ant9_NTNV

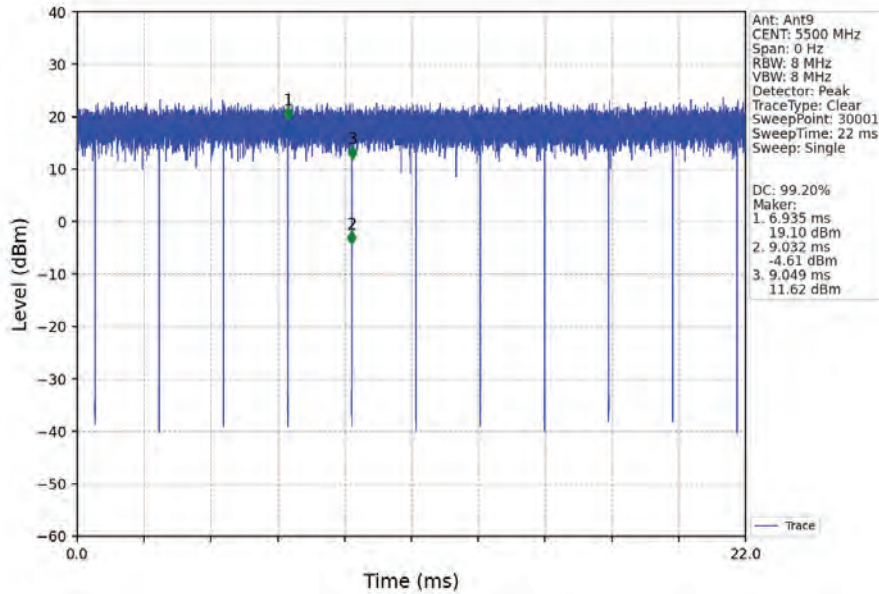

802.11a_MCH_5580MHz_Ant9_NTNV

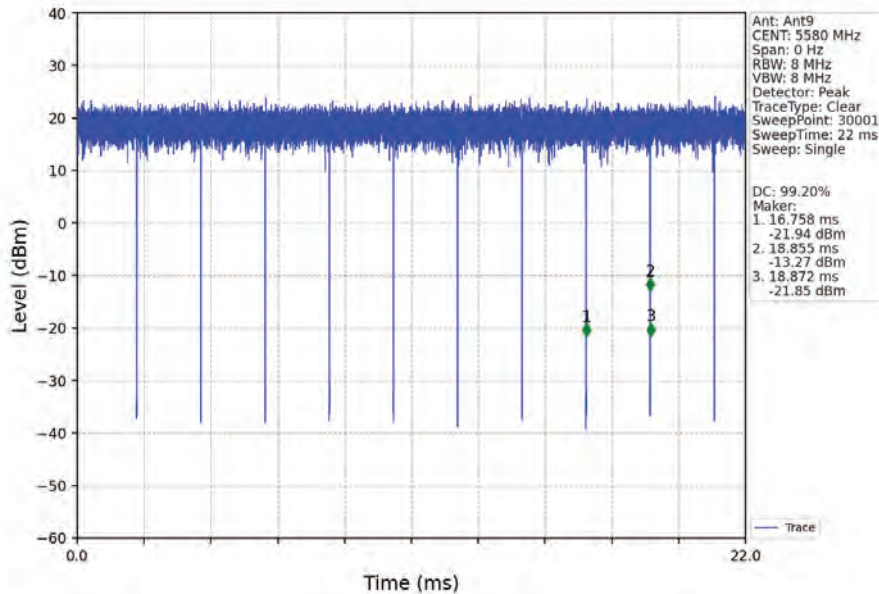

Unless otherwise agreed in writing, this document is issued by the Company subject to its General Conditions of Service printed overleaf, available on request or accessible at <https://www.sgs.com/en/Terms-and-Conditions>. Attention is drawn to the limitation of liability, indemnification and jurisdiction issues defined therein. Any holder of this document is advised that information contained hereon reflects the Company's findings at the time of its intervention only and within the limits of Client's instructions, if any. The Company's sole responsibility is to its Client and this document does not exonerate parties to a transaction from exercising all their rights and obligations under the transaction documents. This document cannot be reproduced except in full, without prior written approval of the Company. Any unauthorized alteration, forgery or falsification of the content or appearance of this document is unlawful and offenders may be prosecuted to the fullest extent of the law. Unless otherwise stated the results shown in this test report refer only to the sample(s) tested and such sample(s) are retained for 30 days only.

Attention: To check the authenticity of testing /inspection report & certificate, please contact us at telephone: (86-755) 8307 1443, or email: CN.Doccheck@sgs.com

802.11a_HCH_5700MHz_Ant9_NTNV

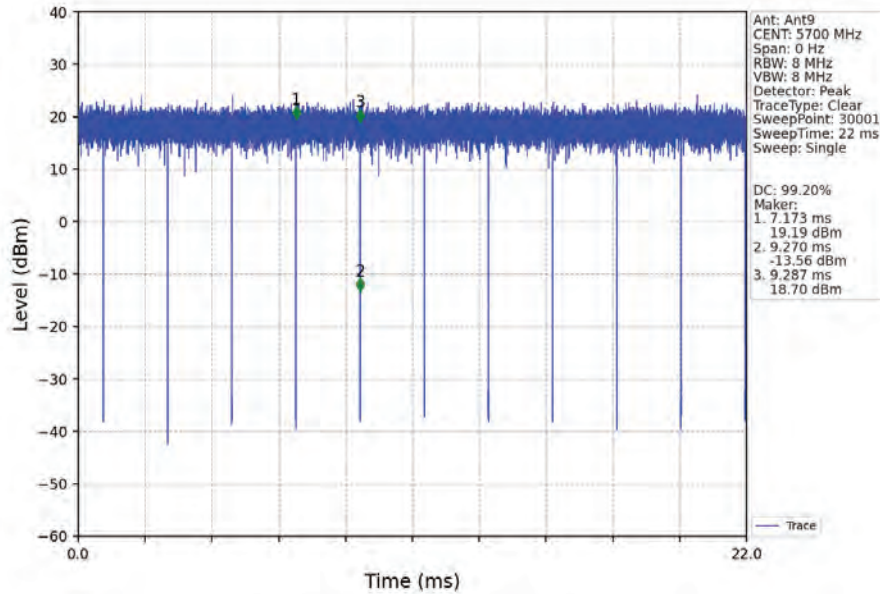

802.11a_LCH_5745MHz_Ant9_NTNV

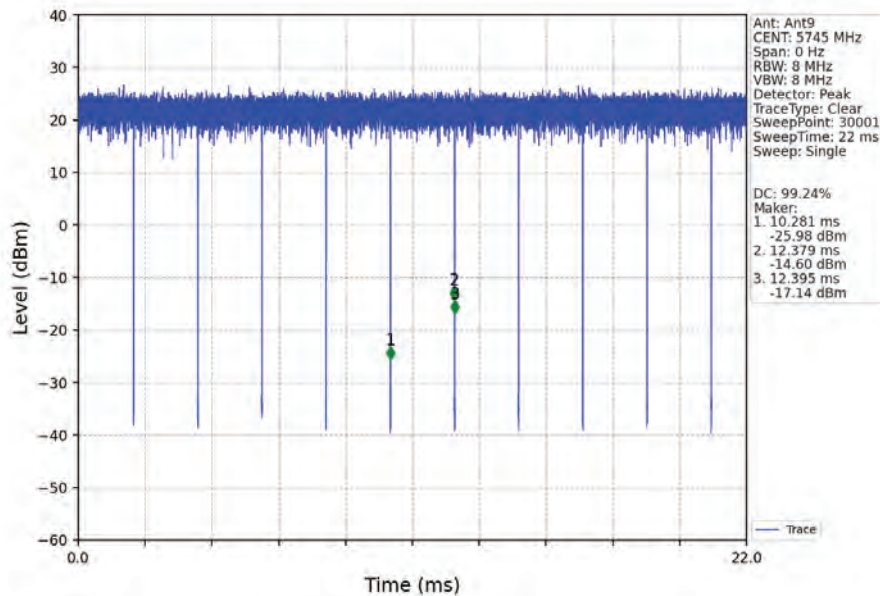

Unless otherwise agreed in writing, this document is issued by the Company subject to its General Conditions of Service printed overleaf, available on request or accessible at <https://www.sgs.com/en/Terms-and-Conditions>. Attention is drawn to the limitation of liability, indemnification and jurisdiction issues defined therein. Any holder of this document is advised that information contained hereon reflects the Company's findings at the time of its intervention only and within the limits of Client's instructions, if any. The Company's sole responsibility is to its Client and this document does not exonerate parties to a transaction from exercising all their rights and obligations under the transaction documents. This document cannot be reproduced except in full, without prior written approval of the Company. Any unauthorized alteration, forgery or falsification of the content or appearance of this document is unlawful and offenders may be prosecuted to the fullest extent of the law. Unless otherwise stated the results shown in this test report refer only to the sample(s) tested and such sample(s) are retained for 30 days only.

802.11a_MCH_5785MHz_Ant9_NTNV

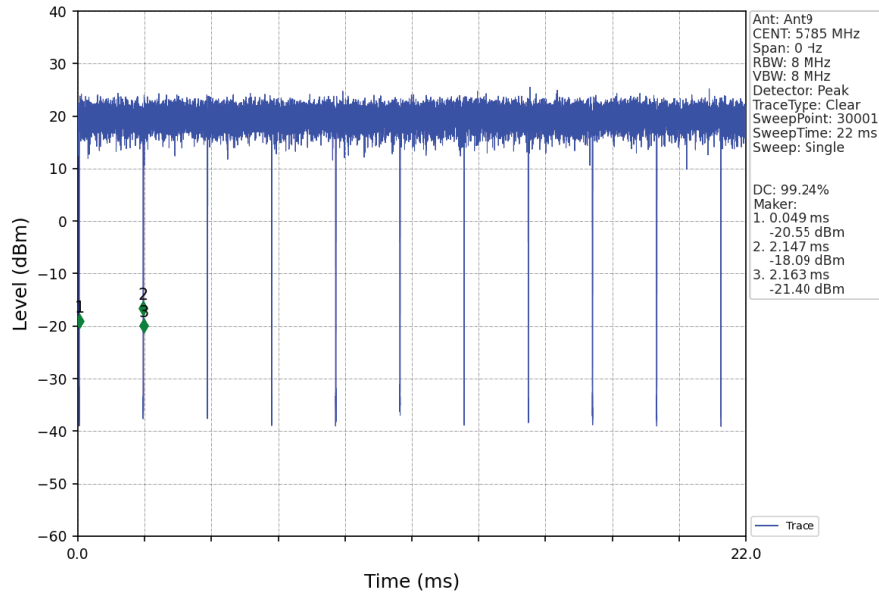

802.11a_HCH_5825MHz_Ant9_NTNV

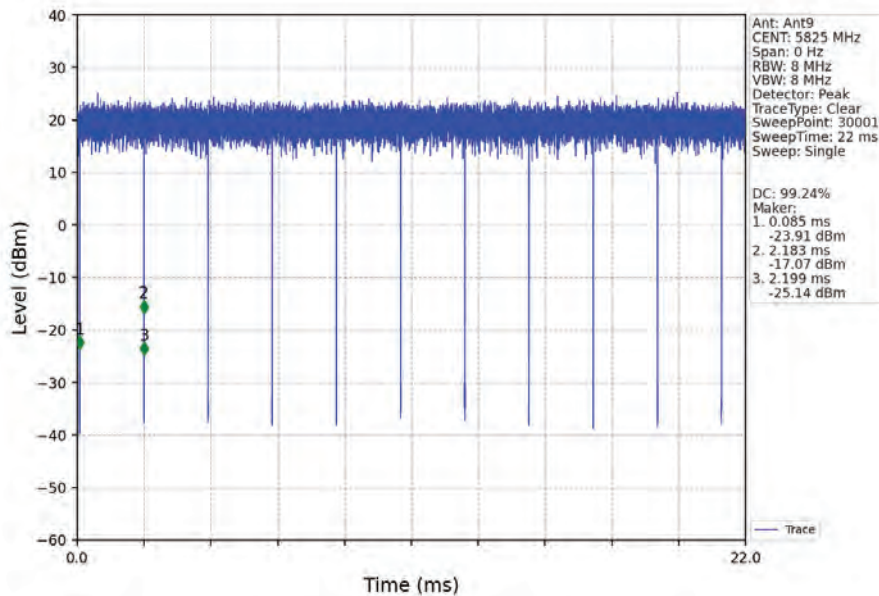

802.11n(HT20)_LCH_5180MHz_Ant9_NTNV

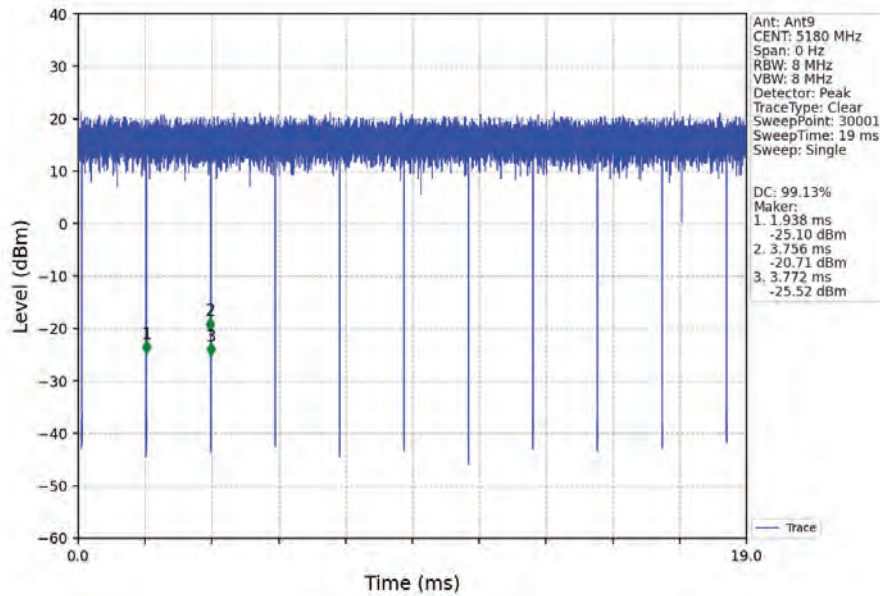

802.11n(HT20)_MCH_5200MHz_Ant9_NTNV

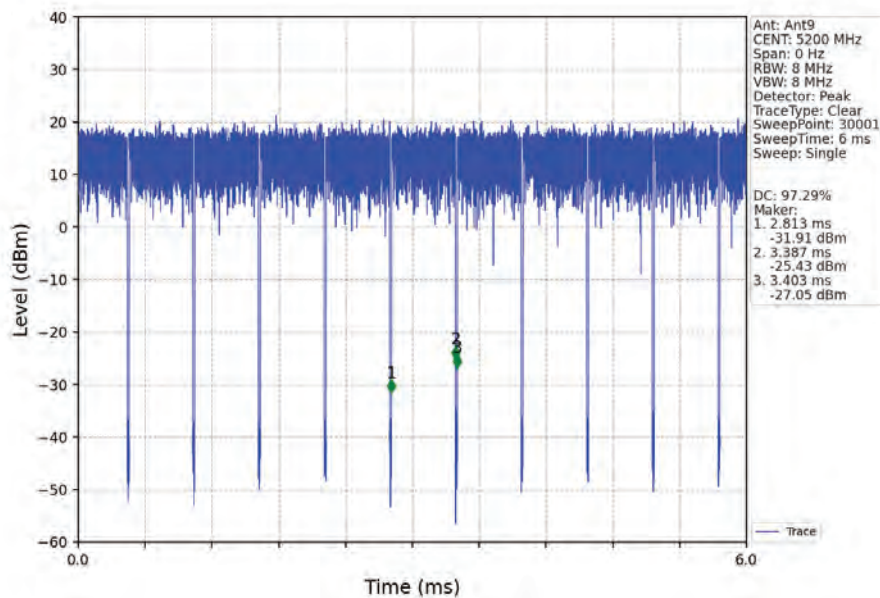

802.11n(HT20)_HCH_5240MHz_Ant9_NTNV

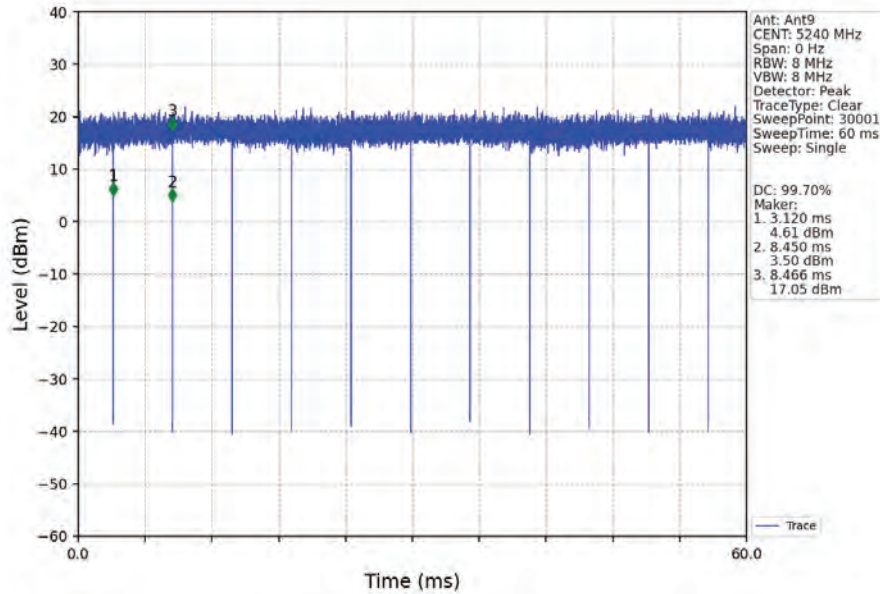

802.11n(HT20)_LCH_5260MHz_Ant9_NTNV

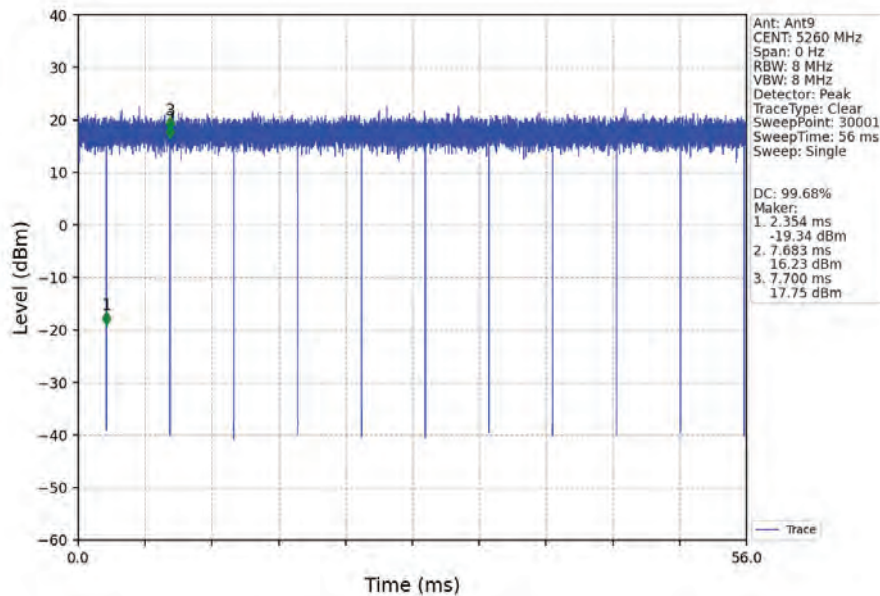

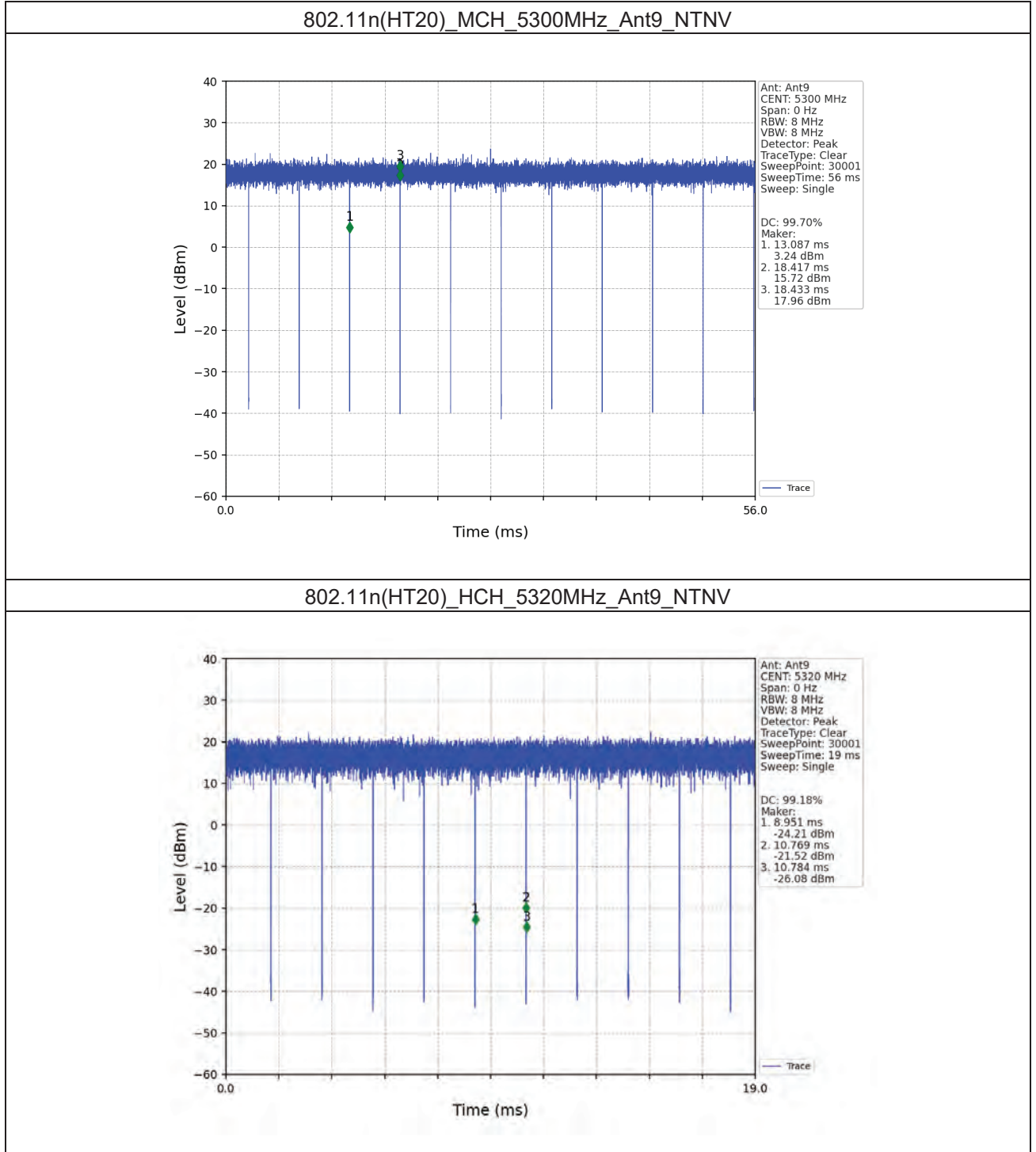

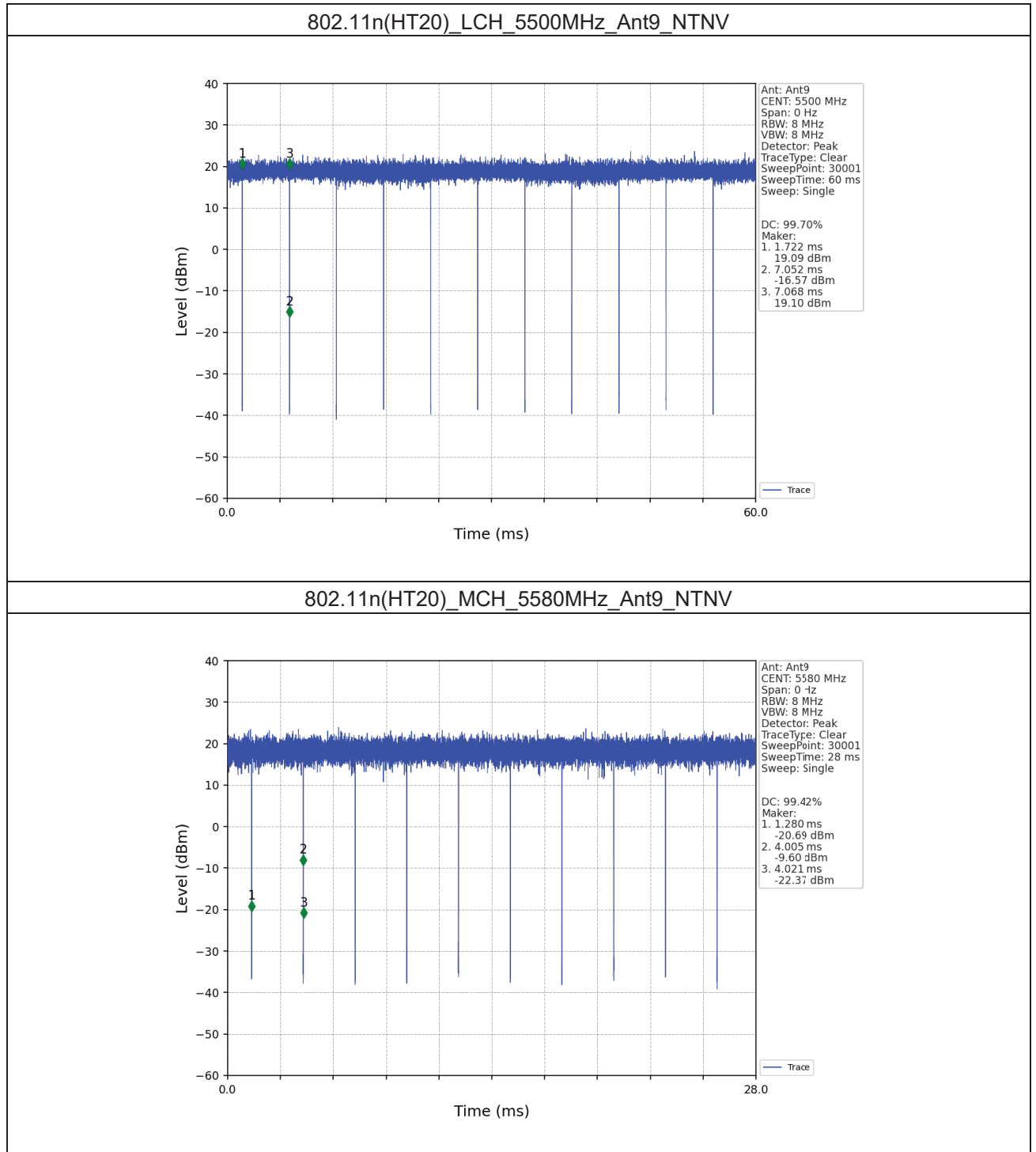

Unless otherwise agreed in writing, this document is issued by the Company subject to its General Conditions of Service printed overleaf, available on request or accessible at <https://www.sgs.com/en/Terms-and-Conditions>. Attention is drawn to the limitation of liability, indemnification and jurisdiction issues defined therein. Any holder of this document is advised that information contained hereon reflects the Company's findings at the time of its intervention only and within the limits of Client's instructions, if any. The Company's sole responsibility is to its Client and this document does not exonerate parties to a transaction from exercising all their rights and obligations under the transaction documents. This document cannot be reproduced except in full, without prior written approval of the Company. Any unauthorized alteration, forgery or falsification of the content or appearance of this document is unlawful and offenders may be prosecuted to the fullest extent of the law. Unless otherwise stated the results shown in this test report refer only to the sample(s) tested and such sample(s) are retained for 30 days only.

802.11n(HT20)_HCH_5700MHz_Ant9_NTNV

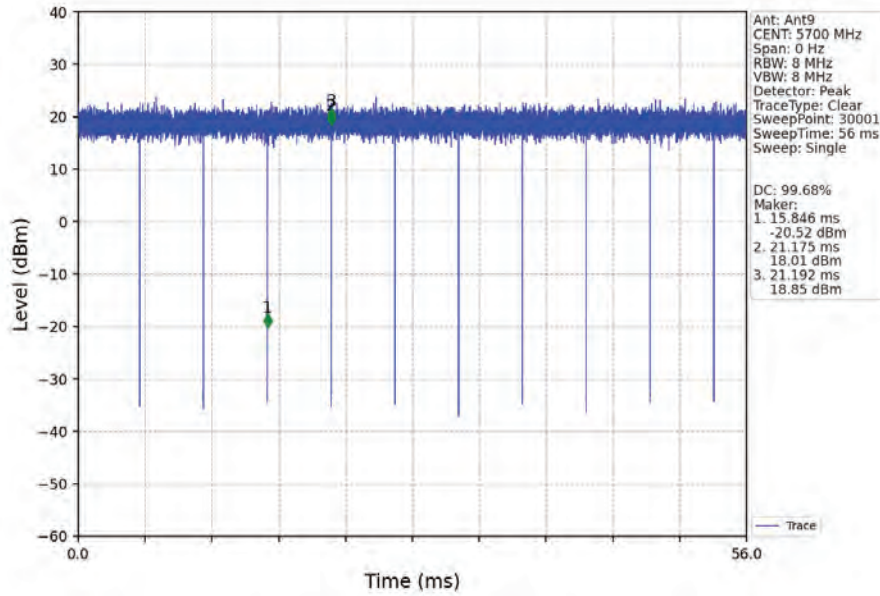

802.11n(HT20)_LCH_5745MHz_Ant9_NTNV

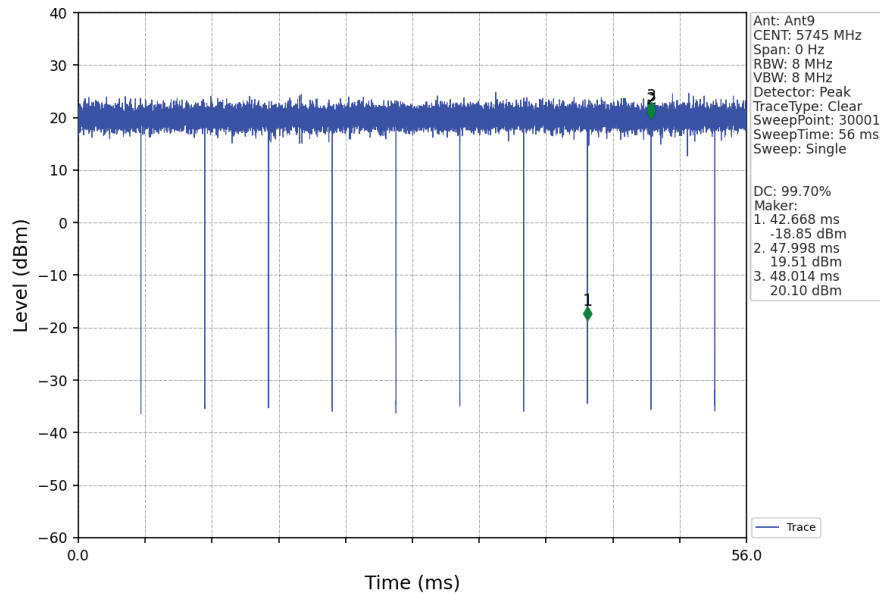

802.11n(HT20)_MCH_5785MHz_Ant9_NTNV

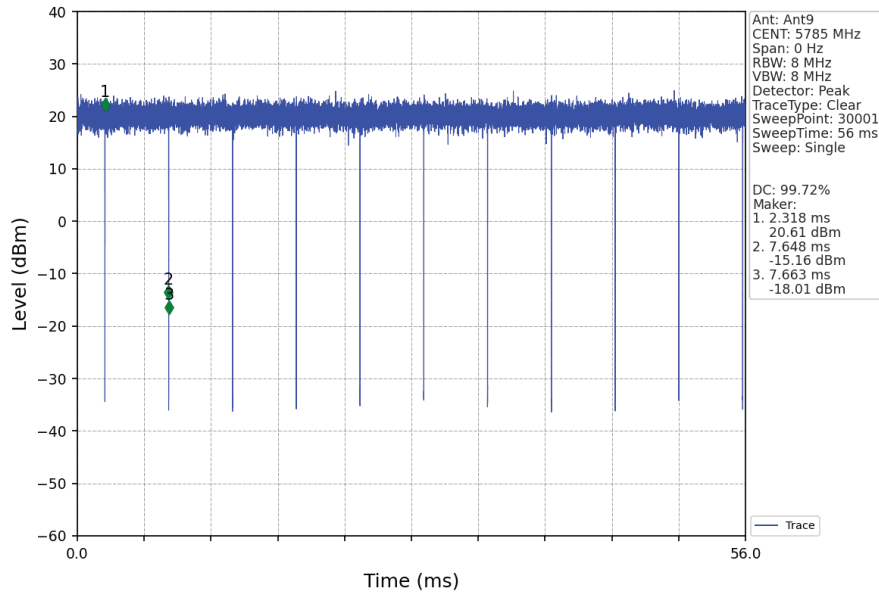

802.11n(HT20)_HCH_5825MHz_Ant9_NTNV

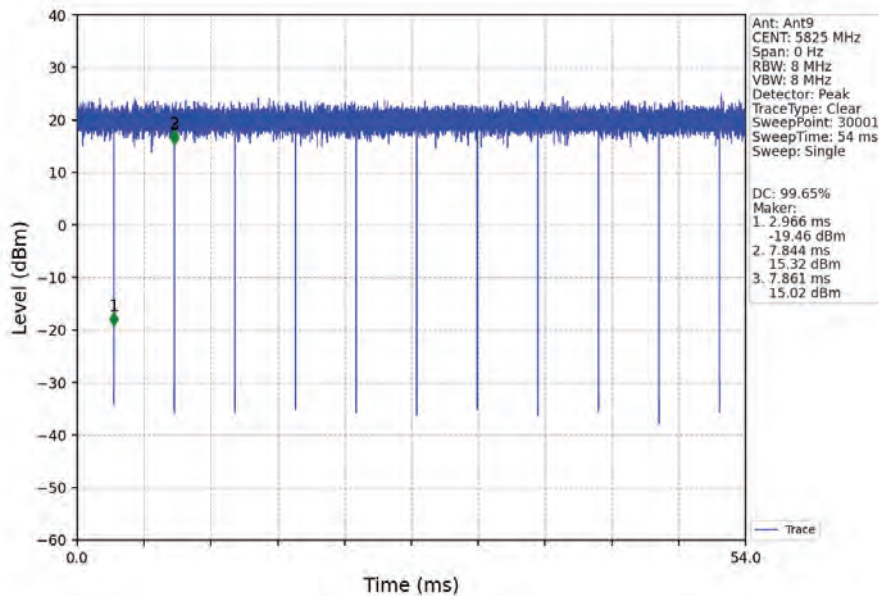

Unless otherwise agreed in writing, this document is issued by the Company subject to its General Conditions of Service printed overleaf, available on request or accessible at <https://www.sgs.com/en/Terms-and-Conditions>. Attention is drawn to the limitation of liability, indemnification and jurisdiction issues defined therein. Any holder of this document is advised that information contained hereon reflects the Company's findings at the time of its intervention only and within the limits of Client's instructions, if any. The Company's sole responsibility is to its Client and this document does not exonerate parties to a transaction from exercising all their rights and obligations under the transaction documents. This document cannot be reproduced except in full, without prior written approval of the Company. Any unauthorized alteration, forgery or falsification of the content or appearance of this document is unlawful and offenders may be prosecuted to the fullest extent of the law. Unless otherwise stated the results shown in this test report refer only to the sample(s) tested and such sample(s) are retained for 30 days only.

802.11n(HT40)_LCH_5190MHz_Ant9_NTNV

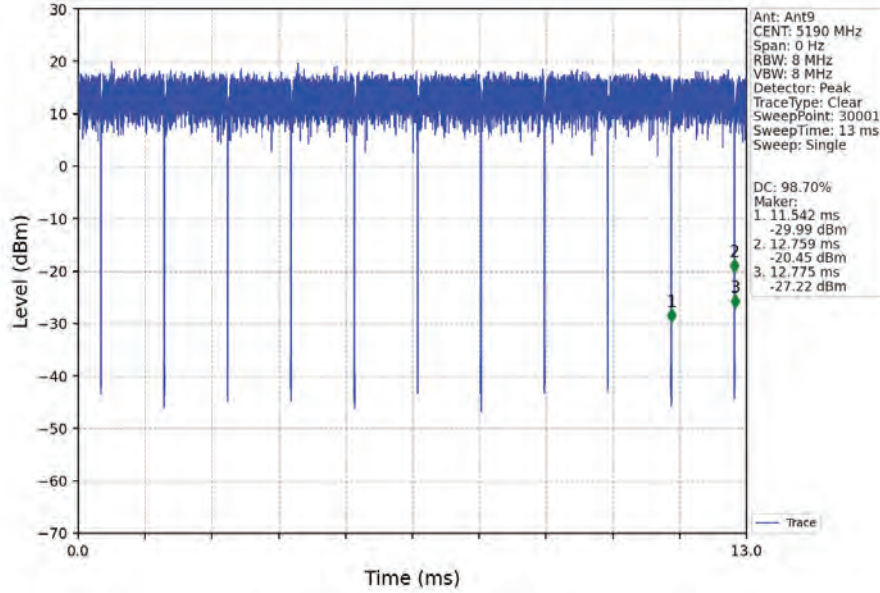

802.11n(HT40)_HCH_5230MHz_Ant9_NTNV

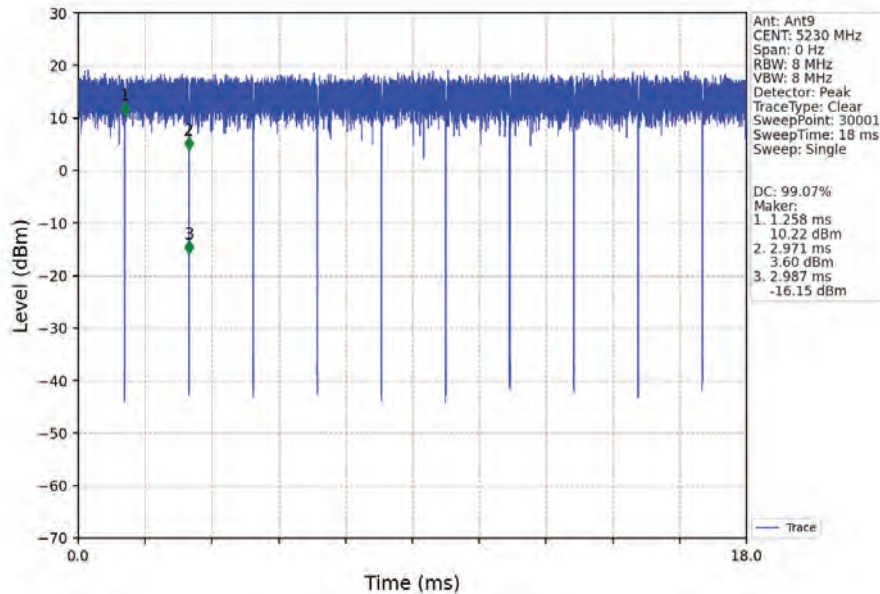

Unless otherwise agreed in writing, this document is issued by the Company subject to its General Conditions of Service printed overleaf, available on request or accessible at <https://www.sgs.com/en/Terms-and-Conditions>. Attention is drawn to the limitation of liability, indemnification and jurisdiction issues defined therein. Any holder of this document is advised that information contained hereon reflects the Company's findings at the time of its intervention only and within the limits of Client's instructions, if any. The Company's sole responsibility is to its Client and this document does not exonerate parties to a transaction from exercising all their rights and obligations under the transaction documents. This document cannot be reproduced except in full, without prior written approval of the Company. Any unauthorized alteration, forgery or falsification of the content or appearance of this document is unlawful and offenders may be prosecuted to the fullest extent of the law. Unless otherwise stated the results shown in this test report refer only to the sample(s) tested and such sample(s) are retained for 30 days only.

802.11n(HT40)_LCH_5270MHz_Ant9_NTNV

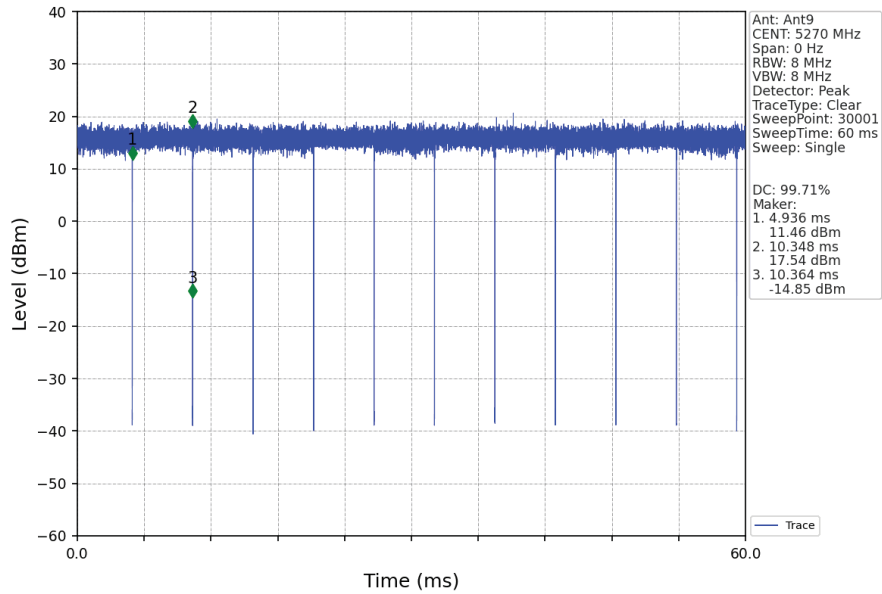

802.11n(HT40)_HCH_5310MHz_Ant9_NTNV

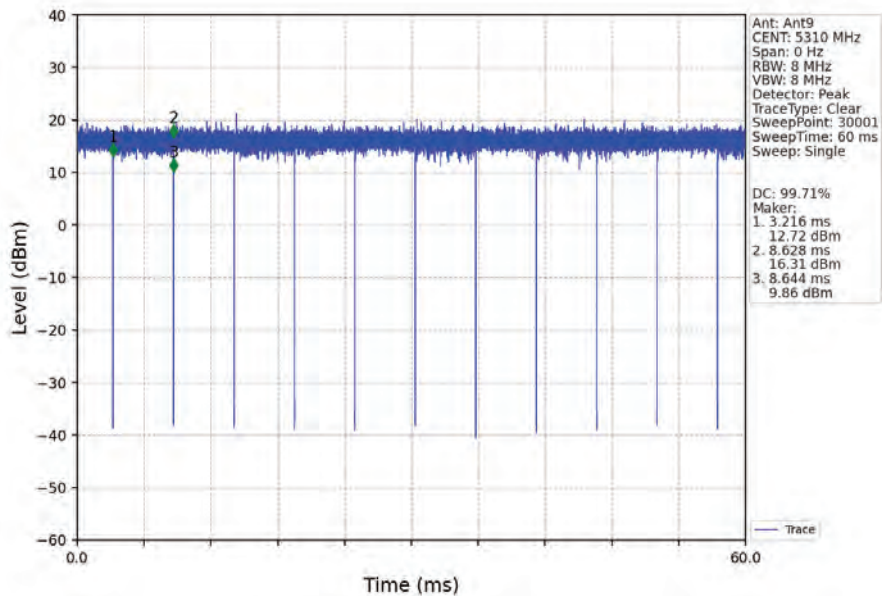

Unless otherwise agreed in writing, this document is issued by the Company subject to its General Conditions of Service printed overleaf, available on request or accessible at <https://www.sgs.com/en/Terms-and-Conditions>. Attention is drawn to the limitation of liability, indemnification and jurisdiction issues defined therein. Any holder of this document is advised that information contained hereon reflects the Company's findings at the time of its intervention only and within the limits of Client's instructions, if any. The Company's sole responsibility is to its Client and this document does not exonerate parties to a transaction from exercising all their rights and obligations under the transaction documents. This document cannot be reproduced except in full, without prior written approval of the Company. Any unauthorized alteration, forgery or falsification of the content or appearance of this document is unlawful and offenders may be prosecuted to the fullest extent of the law. Unless otherwise stated the results shown in this test report refer only to the sample(s) tested and such sample(s) are retained for 30 days only.

802.11n(HT40)_LCH_5510MHz_Ant9_NTNV

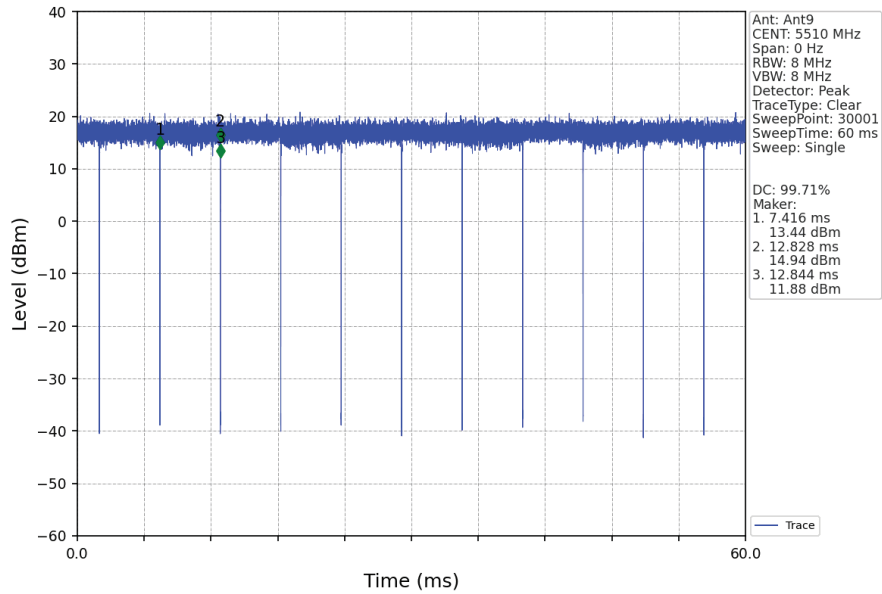

802.11n(HT40)_MCH_5550MHz_Ant9_NTNV

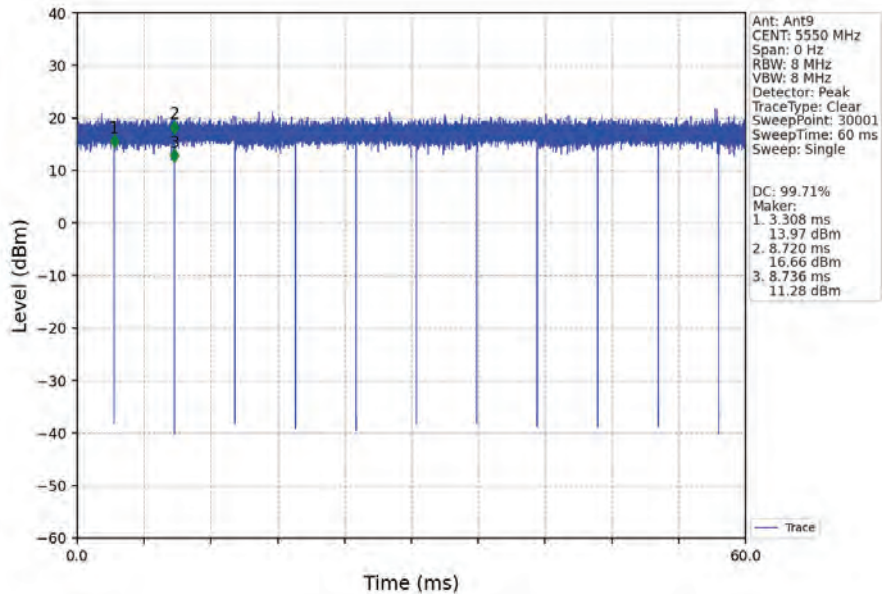

802.11n(HT40)_HCH_5670MHz_Ant9_NTNV

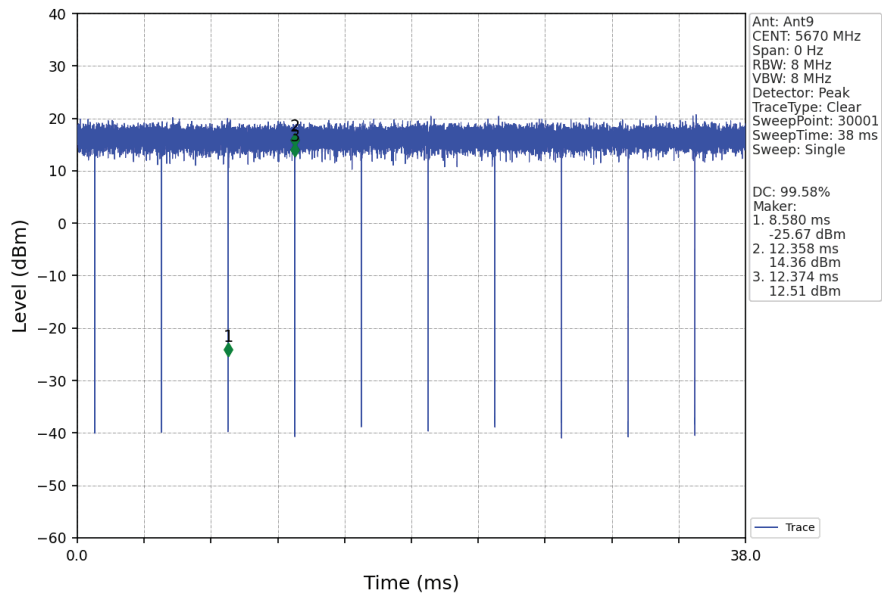

802.11n(HT40)_LCH_5755MHz_Ant9_NTNV

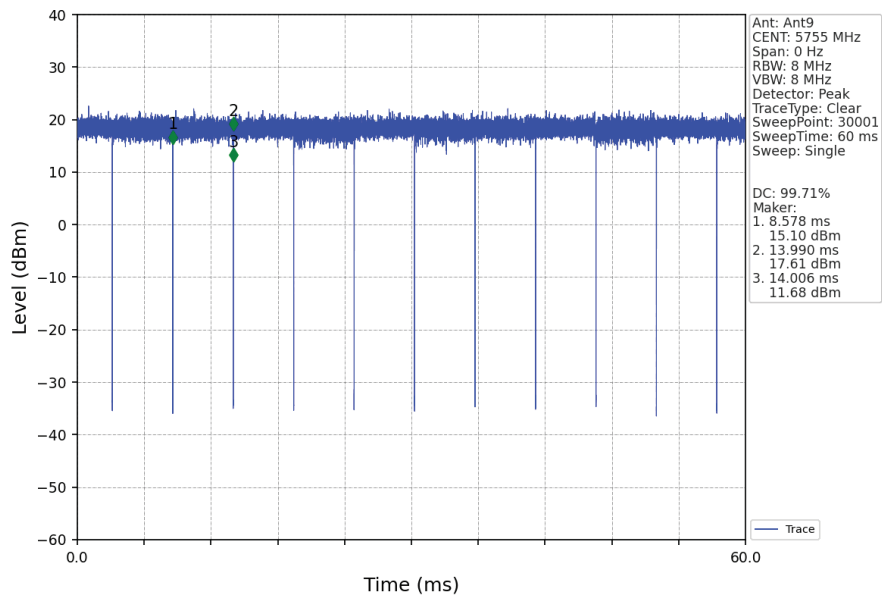

802.11n(HT40)_HCH_5795MHz_Ant9_NTNV

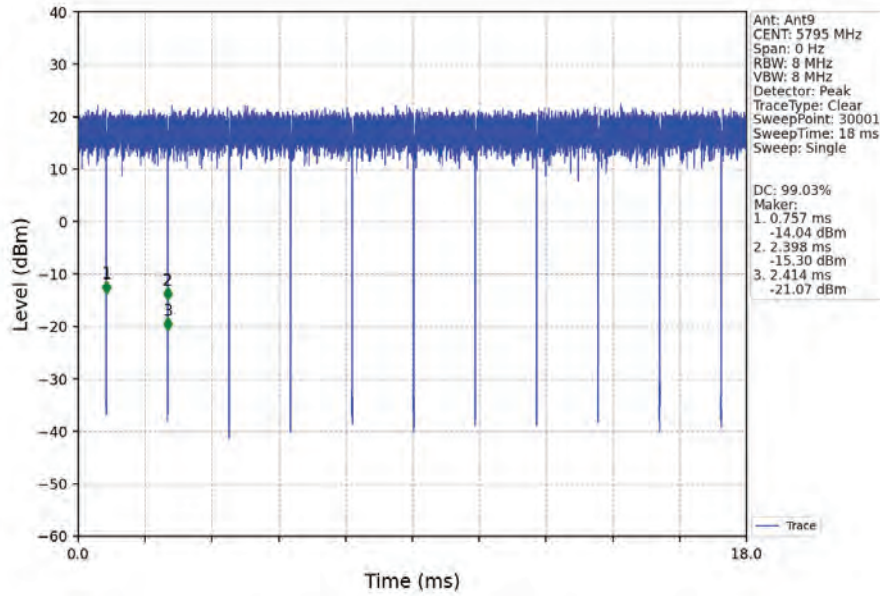

802.11ac(VHT20)_LCH_5180MHz_Ant9_NTNV

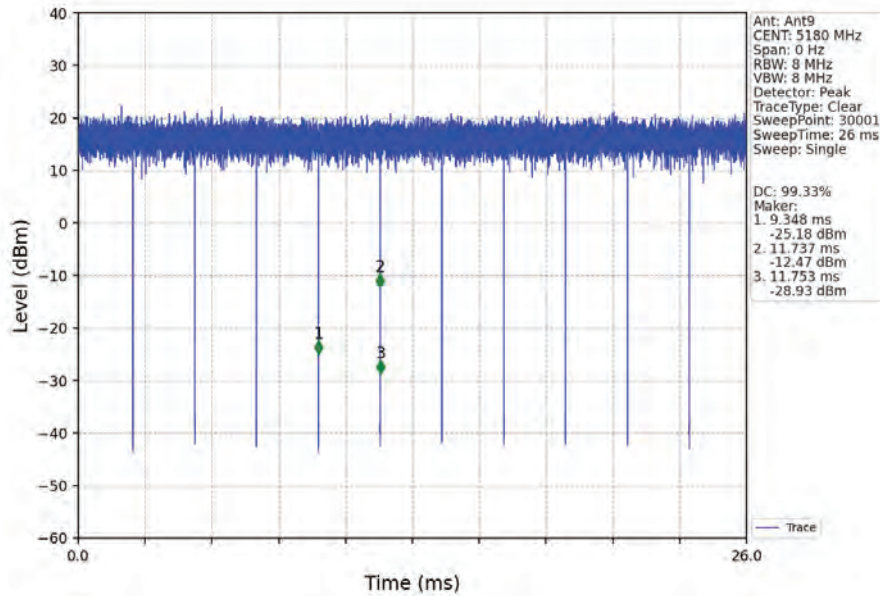

802.11ac(VHT20)_MCH_5200MHz_Ant9_NTNV

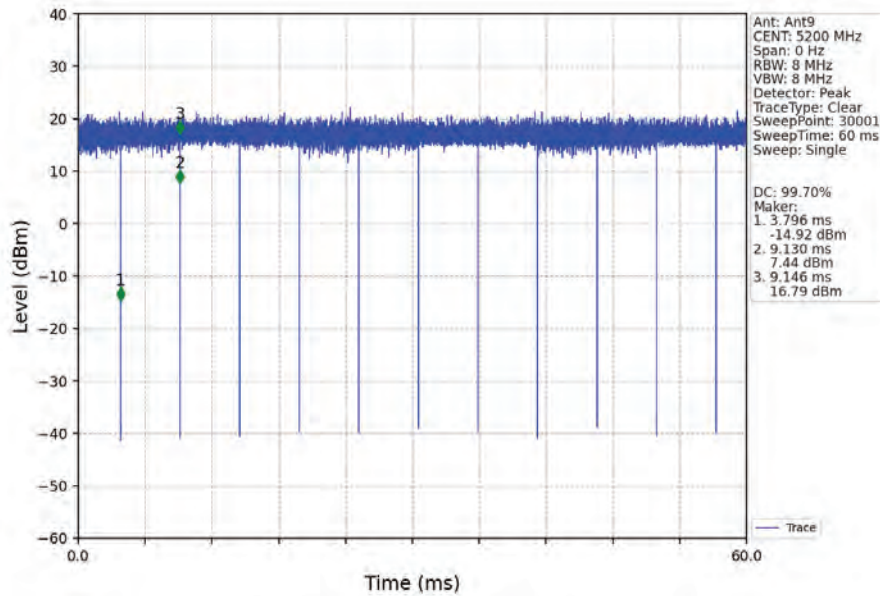

802.11ac(VHT20)_HCH_5240MHz_Ant9_NTNV

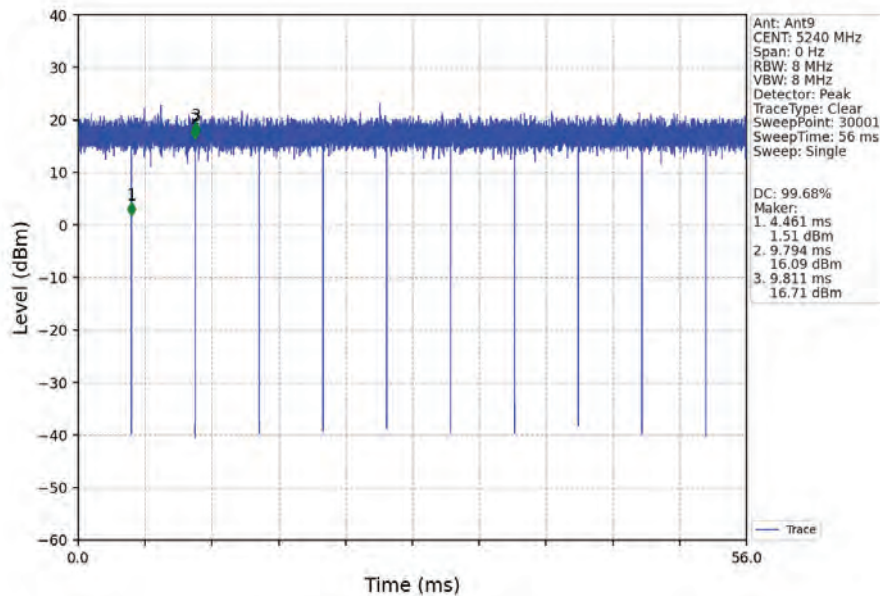

Unless otherwise agreed in writing, this document is issued by the Company subject to its General Conditions of Service printed overleaf, available on request or accessible at <https://www.sgs.com/en/Terms-and-Conditions>. Attention is drawn to the limitation of liability, indemnification and jurisdiction issues defined therein. Any holder of this document is advised that information contained hereon reflects the Company's findings at the time of its intervention only and within the limits of Client's instructions, if any. The Company's sole responsibility is to its Client and this document does not exonerate parties to a transaction from exercising all their rights and obligations under the transaction documents. This document cannot be reproduced except in full, without prior written approval of the Company. Any unauthorized alteration, forgery or falsification of the content or appearance of this document is unlawful and offenders may be prosecuted to the fullest extent of the law. Unless otherwise stated the results shown in this test report refer only to the sample(s) tested and such sample(s) are retained for 30 days only.

802.11ac(VHT20)_LCH_5260MHz_Ant9_NTNV

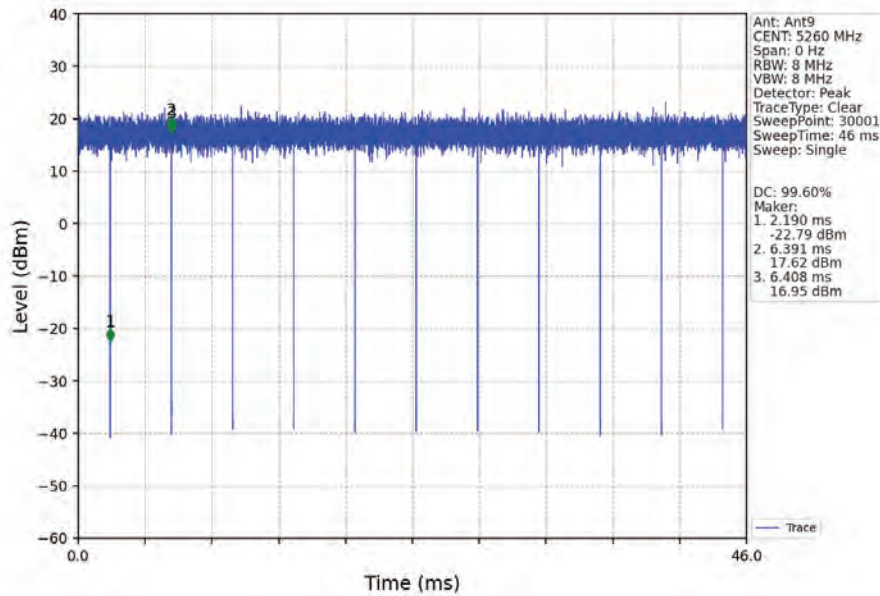

802.11ac(VHT20)_MCH_5300MHz_Ant9_NTNV

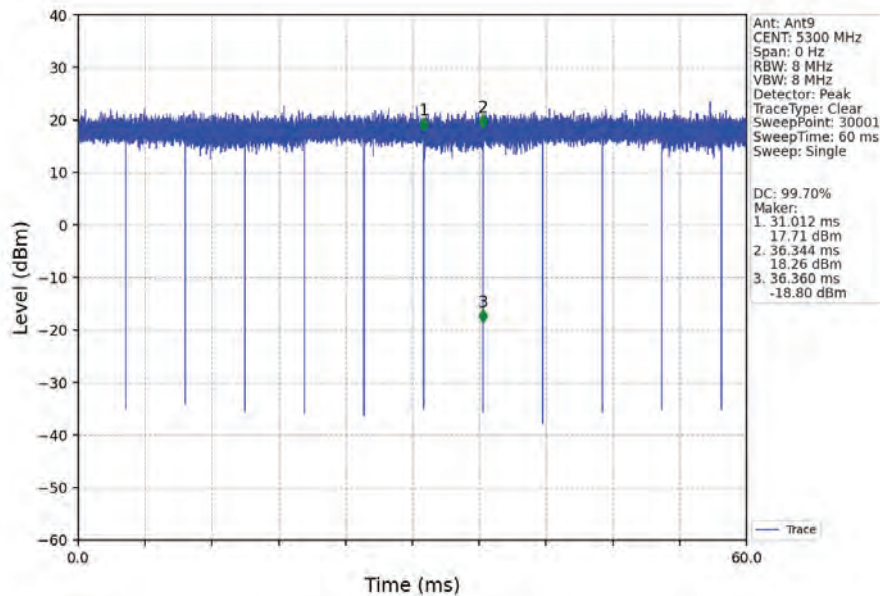

Unless otherwise agreed in writing, this document is issued by the Company subject to its General Conditions of Service printed overleaf, available on request or accessible at <https://www.sgs.com/en/Terms-and-Conditions>. Attention is drawn to the limitation of liability, indemnification and jurisdiction issues defined therein. Any holder of this document is advised that information contained hereon reflects the Company's findings at the time of its intervention only and within the limits of Client's instructions, if any. The Company's sole responsibility is to its Client and this document does not exonerate parties to a transaction from exercising all their rights and obligations under the transaction documents. This document cannot be reproduced except in full, without prior written approval of the Company. Any unauthorized alteration, forgery or falsification of the content or appearance of this document is unlawful and offenders may be prosecuted to the fullest extent of the law. Unless otherwise stated the results shown in this test report refer only to the sample(s) tested and such sample(s) are retained for 30 days only.

802.11ac(VHT20)_HCH_5320MHz_Ant9_NTNV

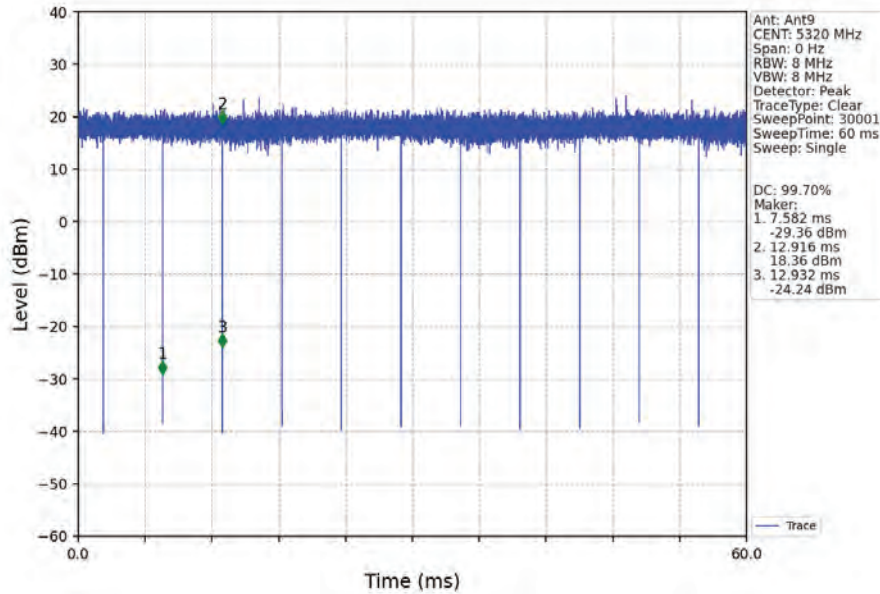

802.11ac(VHT20)_LCH_5500MHz_Ant9_NTNV

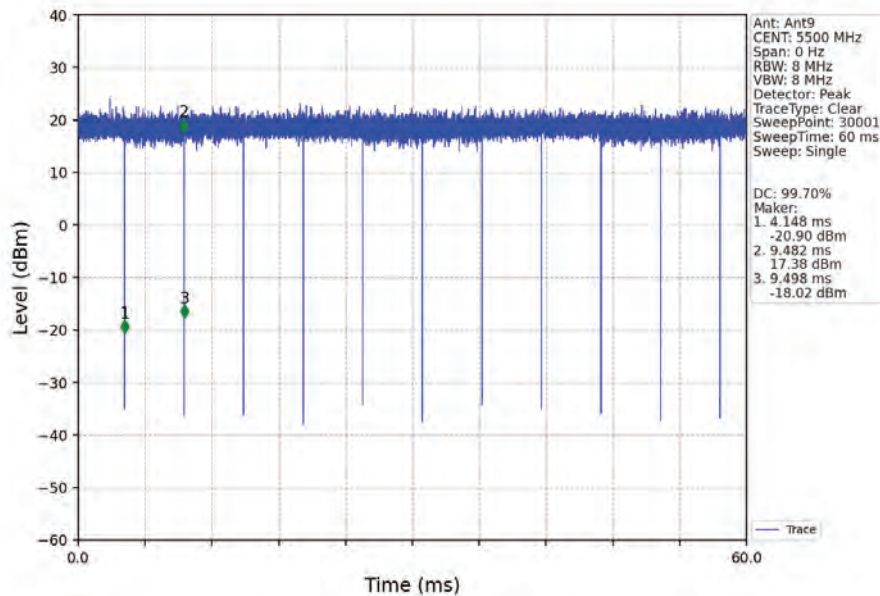

Unless otherwise agreed in writing, this document is issued by the Company subject to its General Conditions of Service printed overleaf, available on request or accessible at <https://www.sgs.com/en/Terms-and-Conditions>. Attention is drawn to the limitation of liability, indemnification and jurisdiction issues defined therein. Any holder of this document is advised that information contained hereon reflects the Company's findings at the time of its intervention only and within the limits of Client's instructions, if any. The Company's sole responsibility is to its Client and this document does not exonerate parties to a transaction from exercising all their rights and obligations under the transaction documents. This document cannot be reproduced except in full, without prior written approval of the Company. Any unauthorized alteration, forgery or falsification of the content or appearance of this document is unlawful and offenders may be prosecuted to the fullest extent of the law. Unless otherwise stated the results shown in this test report refer only to the sample(s) tested and such sample(s) are retained for 30 days only.

802.11ac(VHT20)_MCH_5580MHz_Ant9_NTNV

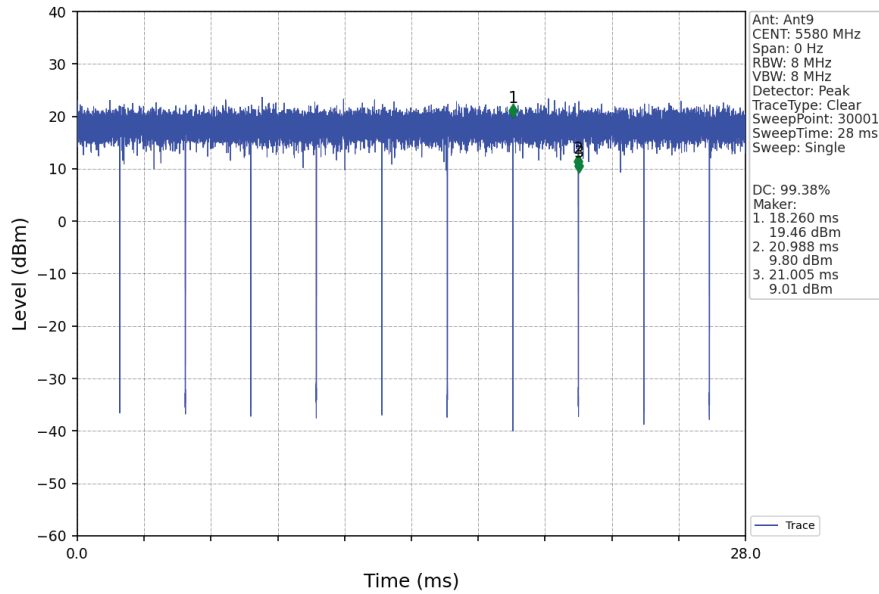

802.11ac(VHT20)_HCH_5700MHz_Ant9_NTNV

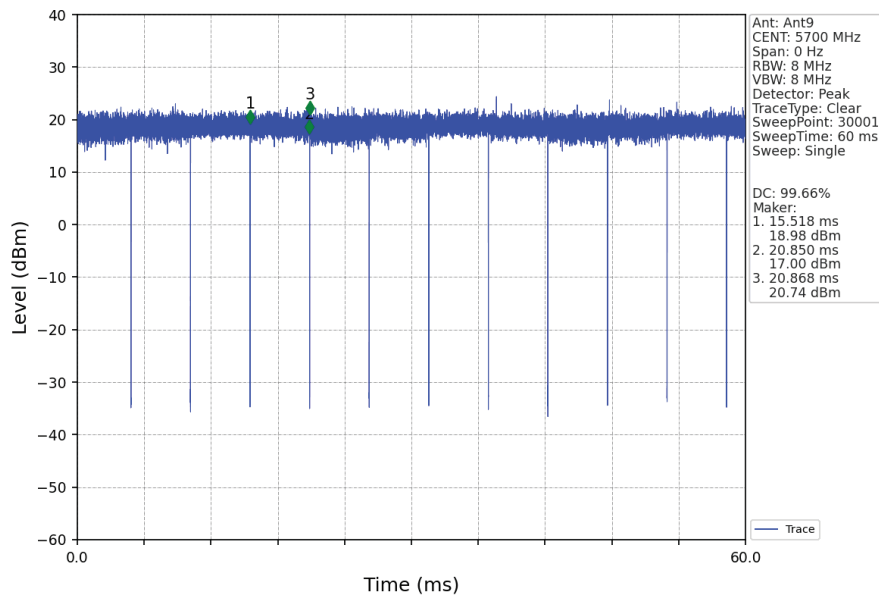

Unless otherwise agreed in writing, this document is issued by the Company subject to its General Conditions of Service printed overleaf, available on request or accessible at <https://www.sgs.com/en/Terms-and-Conditions>. Attention is drawn to the limitation of liability, indemnification and jurisdiction issues defined therein. Any holder of this document is advised that information contained hereon reflects the Company's findings at the time of its intervention only and within the limits of Client's instructions, if any. The Company's sole responsibility is to its Client and this document does not exonerate parties to a transaction from exercising all their rights and obligations under the transaction documents. This document cannot be reproduced except in full, without prior written approval of the Company. Any unauthorized alteration, forgery or falsification of the content or appearance of this document is unlawful and offenders may be prosecuted to the fullest extent of the law. Unless otherwise stated the results shown in this test report refer only to the sample(s) tested and such sample(s) are retained for 30 days only.

802.11ac(VHT20)_LCH_5745MHz_Ant9_NTNV

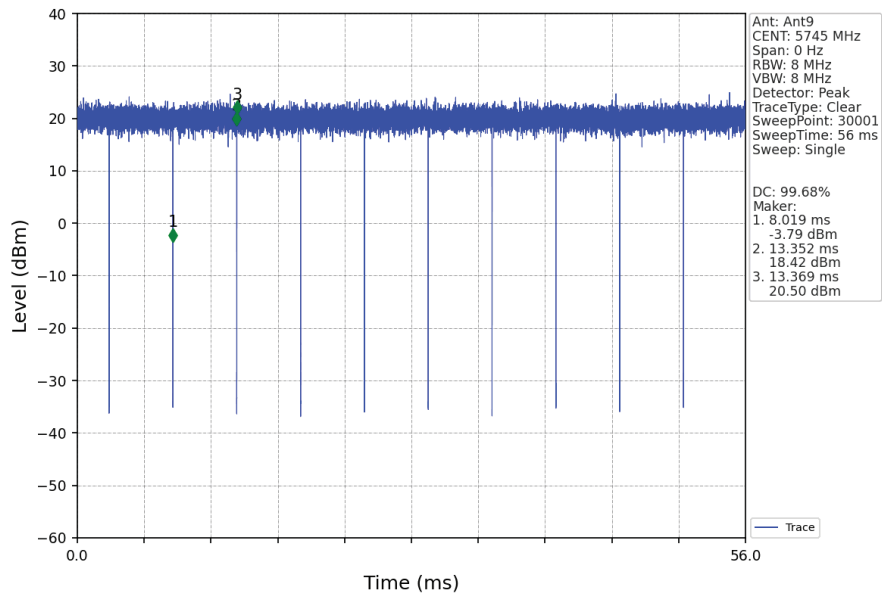

802.11ac(VHT20)_MCH_5785MHz_Ant9_NTNV

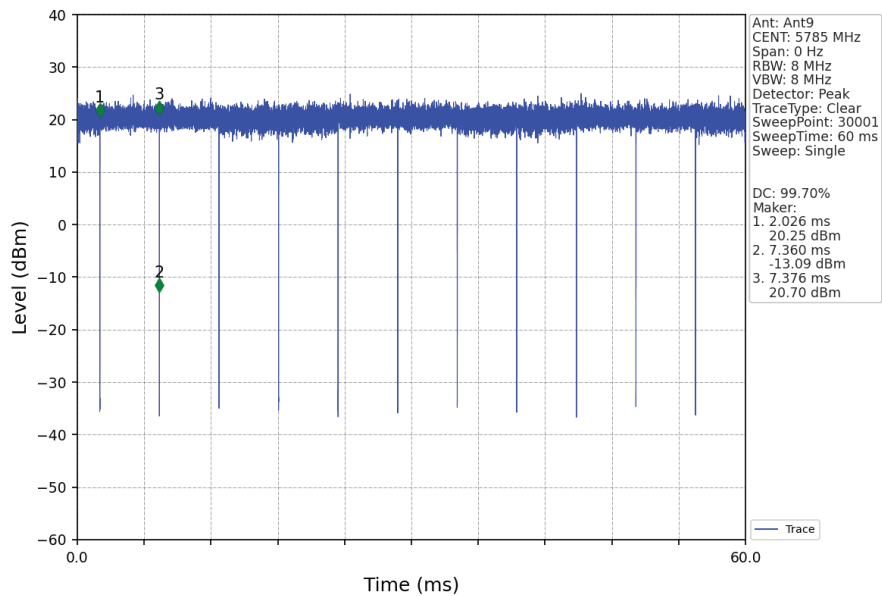

802.11ac(VHT20)_HCH_5825MHz_Ant9_NTNV

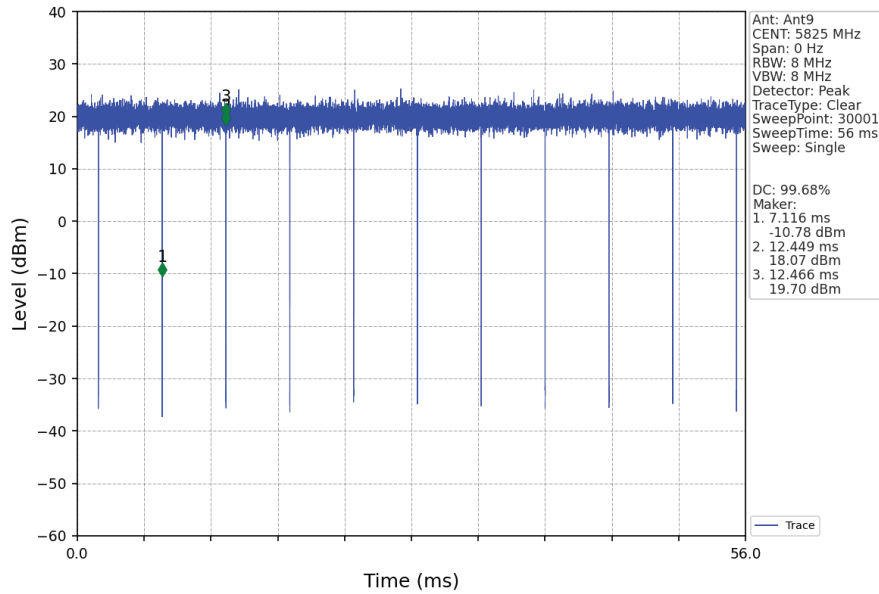

802.11ac(VHT40)_LCH_5190MHz_Ant9_NTNV

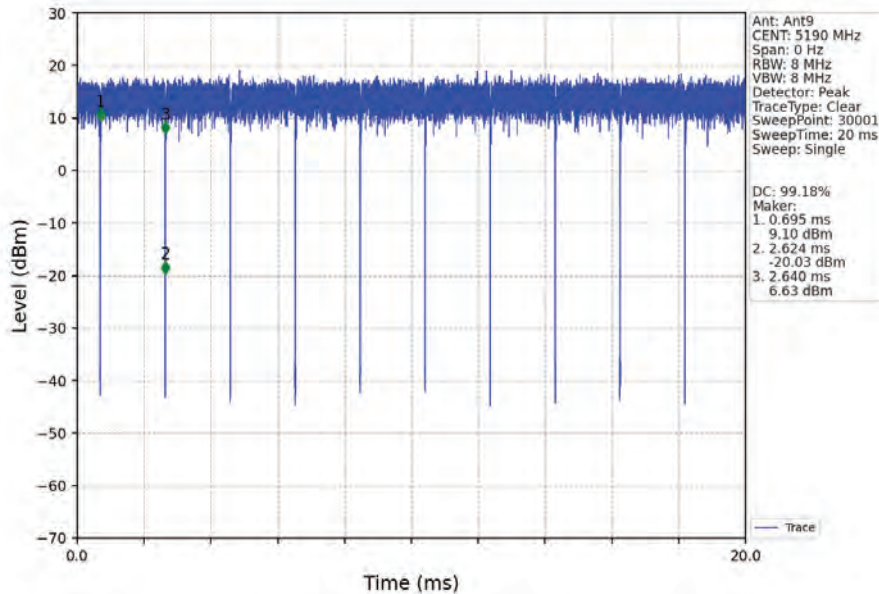

Unless otherwise agreed in writing, this document is issued by the Company subject to its General Conditions of Service printed overleaf, available on request or accessible at <https://www.sgs.com/en/Terms-and-Conditions>. Attention is drawn to the limitation of liability, indemnification and jurisdiction issues defined therein. Any holder of this document is advised that information contained hereon reflects the Company's findings at the time of its intervention only and within the limits of Client's instructions, if any. The Company's sole responsibility is to its Client and this document does not exonerate parties to a transaction from exercising all their rights and obligations under the transaction documents. This document cannot be reproduced except in full, without prior written approval of the Company. Any unauthorized alteration, forgery or falsification of the content or appearance of this document is unlawful and offenders may be prosecuted to the fullest extent of the law. Unless otherwise stated the results shown in this test report refer only to the sample(s) tested and such sample(s) are retained for 30 days only.

802.11ac(VHT40)_HCH_5230MHz_Ant9_NTNV

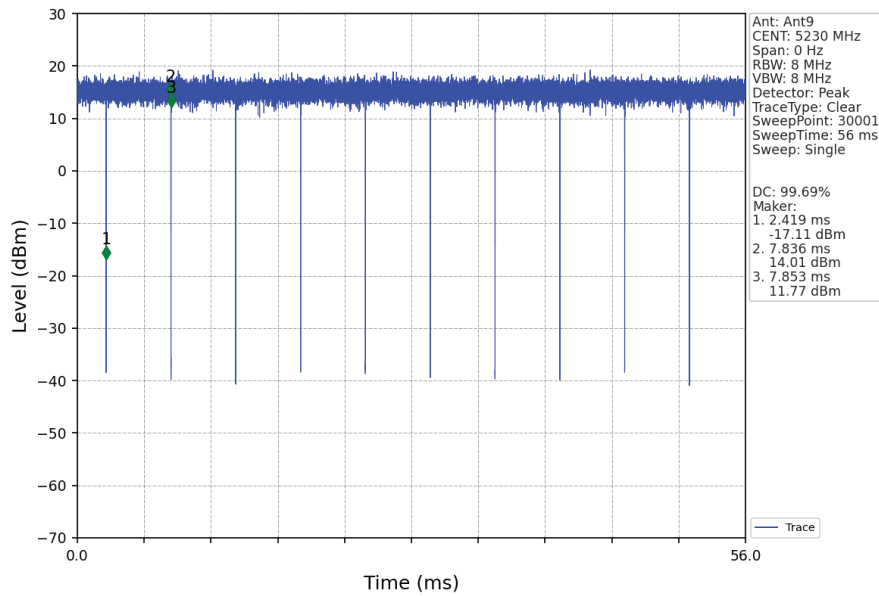

802.11ac(VHT40)_LCH_5270MHz_Ant9_NTNV

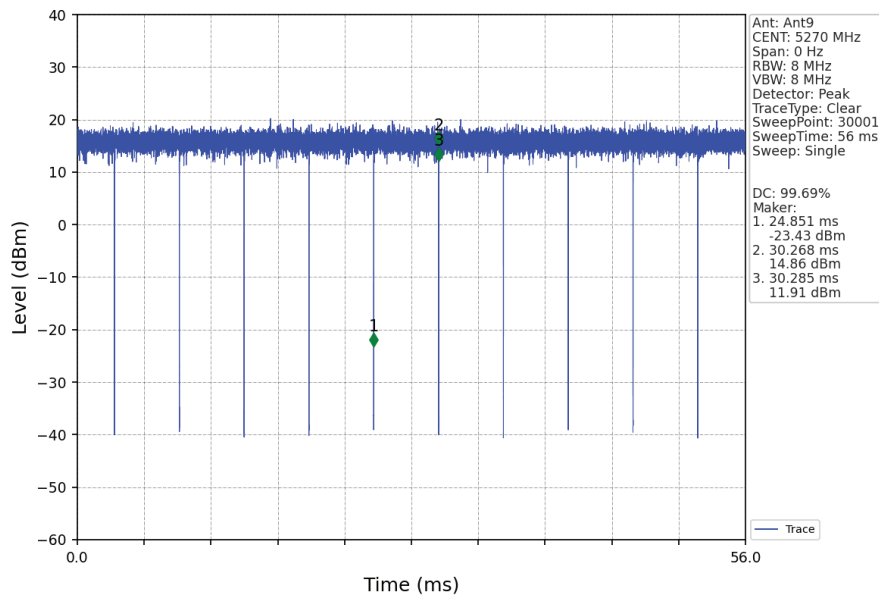

802.11ac(VHT40)_HCH_5310MHz_Ant9_NTNV

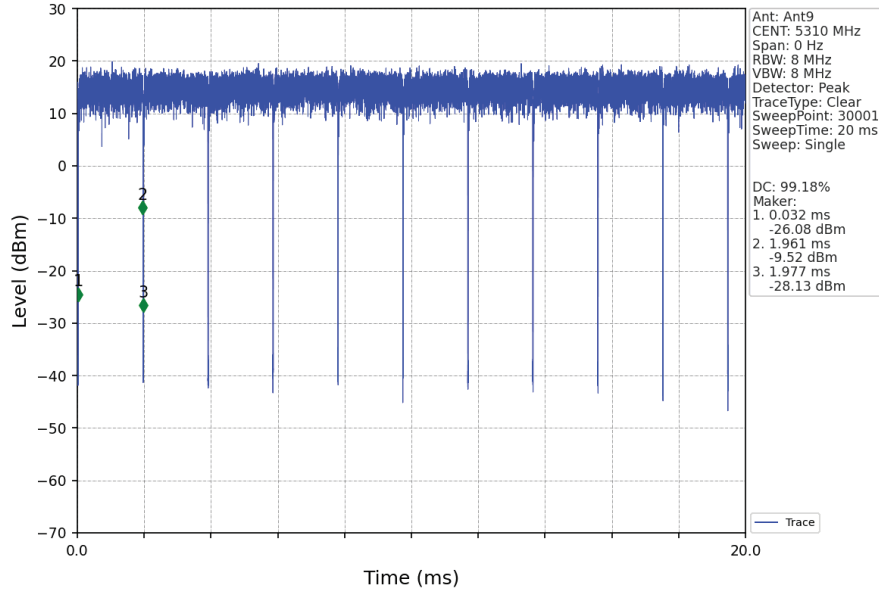

802.11ac(VHT40)_LCH_5510MHz_Ant9_NTNV

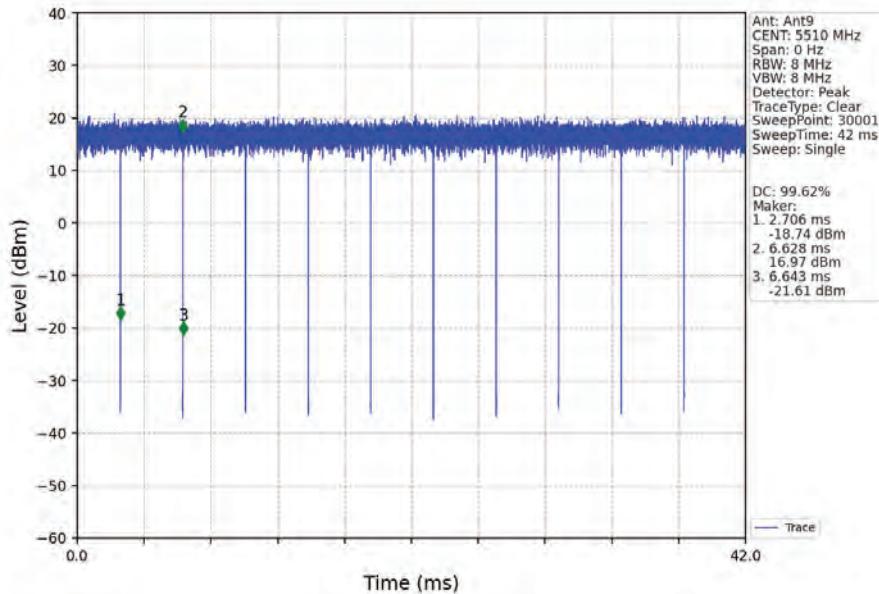

802.11ac(VHT40)_MCH_5550MHz_Ant9_NTNV

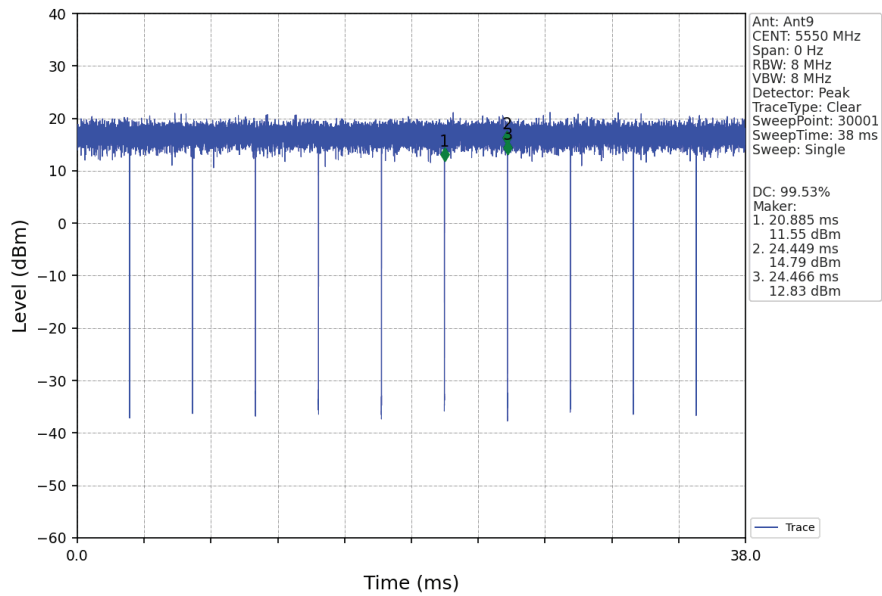

802.11ac(VHT40)_HCH_5670MHz_Ant9_NTNV

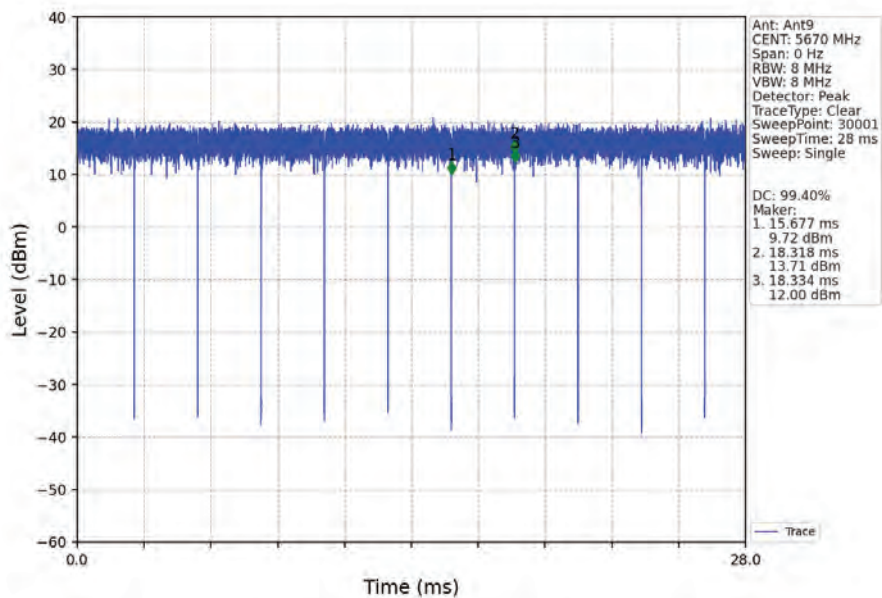

Unless otherwise agreed in writing, this document is issued by the Company subject to its General Conditions of Service printed overleaf, available on request or accessible at <https://www.sgs.com/en/Terms-and-Conditions>. Attention is drawn to the limitation of liability, indemnification and jurisdiction issues defined therein. Any holder of this document is advised that information contained hereon reflects the Company's findings at the time of its intervention only and within the limits of Client's instructions, if any. The Company's sole responsibility is to its Client and this document does not exonerate parties to a transaction from exercising all their rights and obligations under the transaction documents. This document cannot be reproduced except in full, without prior written approval of the Company. Any unauthorized alteration, forgery or falsification of the content or appearance of this document is unlawful and offenders may be prosecuted to the fullest extent of the law. Unless otherwise stated the results shown in this test report refer only to the sample(s) tested and such sample(s) are retained for 30 days only.

802.11ac(VHT40)_LCH_5755MHz_Ant9_NTNV

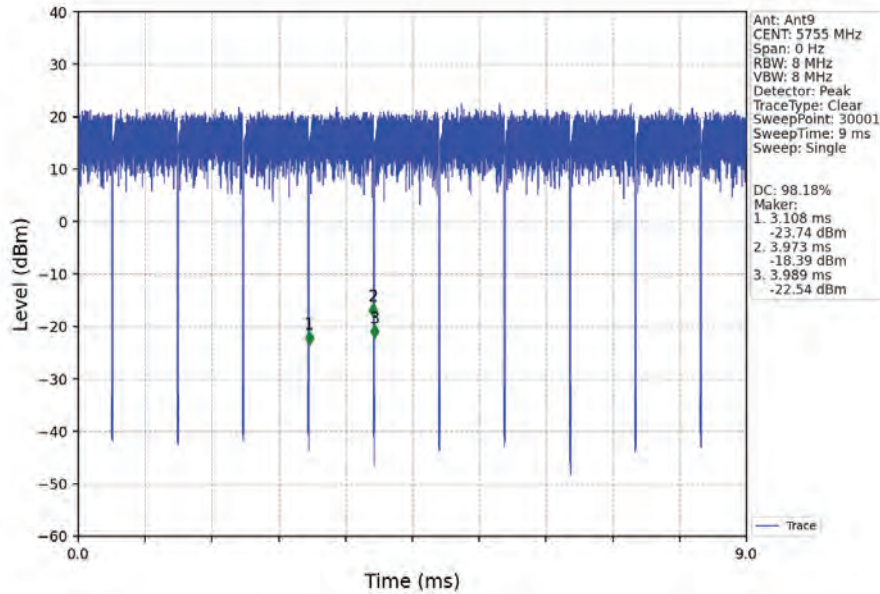

802.11ac(VHT40)_HCH_5795MHz_Ant9_NTNV

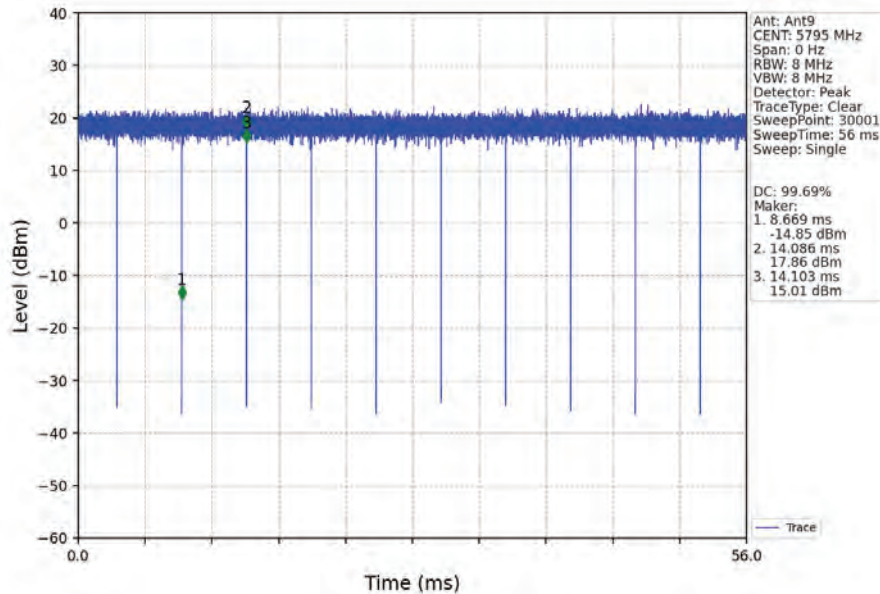

802.11ac(VHT80)_MCH_5210MHz_Ant9_NTNV

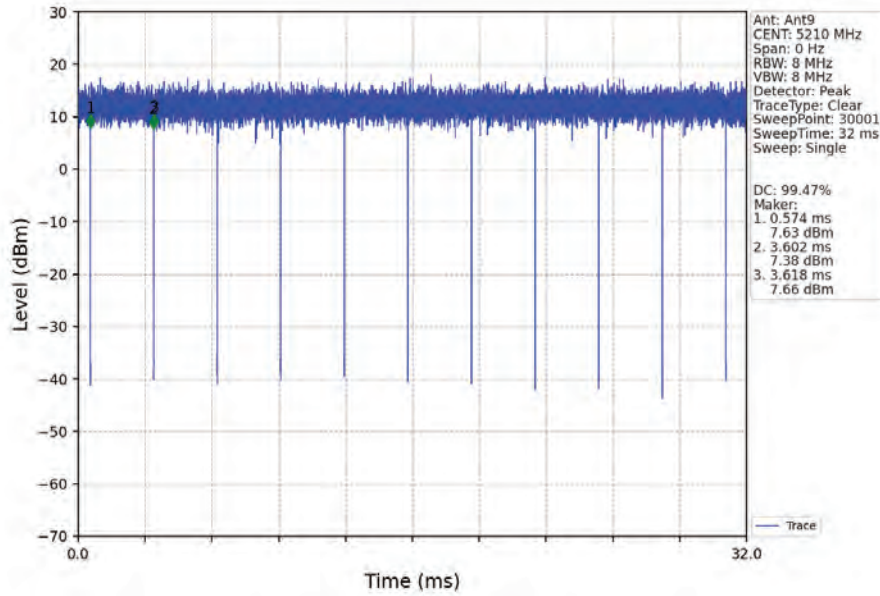

802.11ac(VHT80)_MCH_5290MHz_Ant9_NTNV

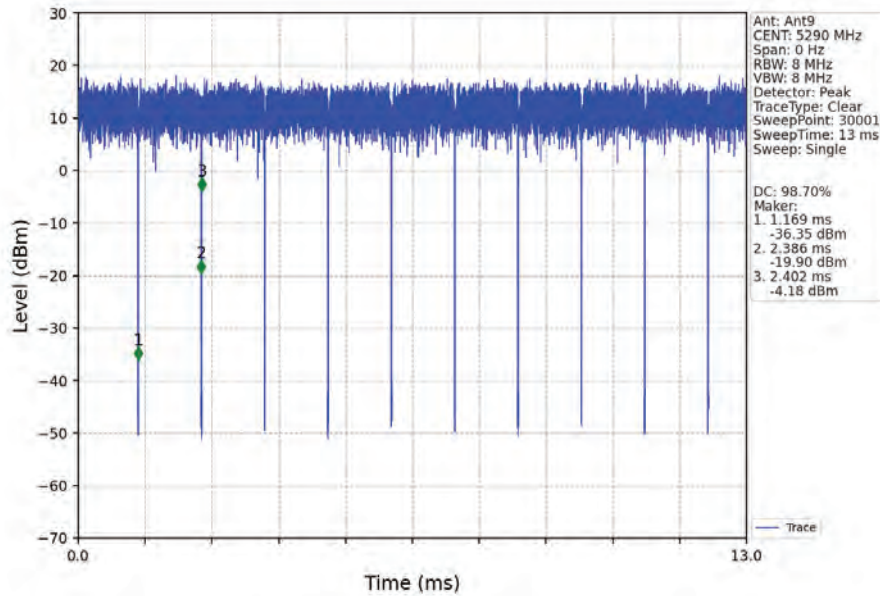

802.11ac(VHT80)_LCH_5530MHz_Ant9_NTNV

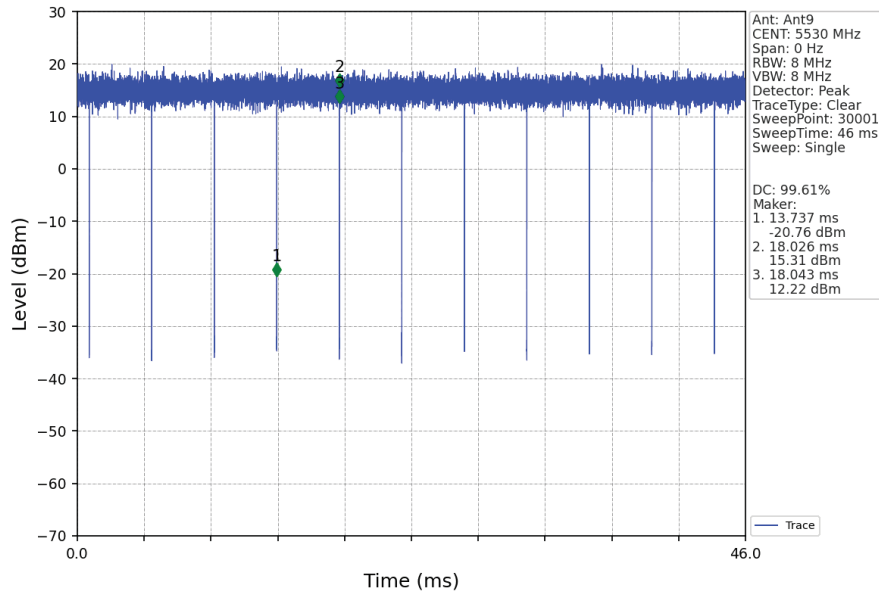

802.11ac(VHT80)_HCH_5610MHz_Ant9_NTNV

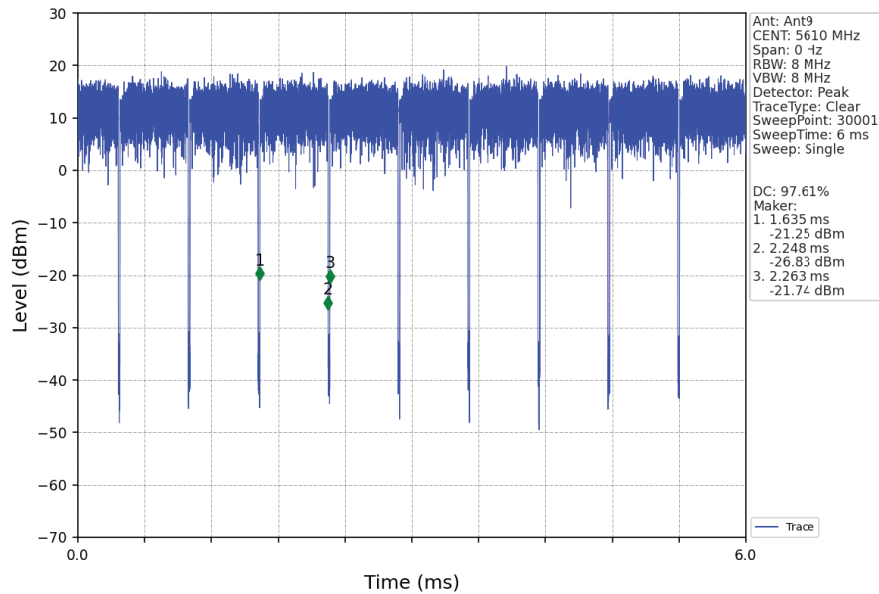

802.11ac(VHT80)_MCH_5775MHz_Ant9_NTNV

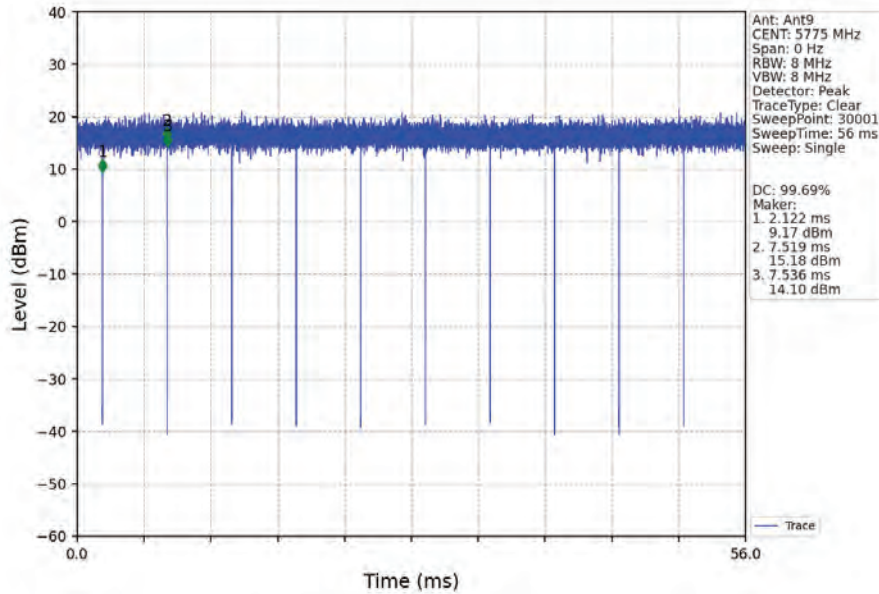

802.11ac(VHT160)_MCH_5570MHz_Ant9_NTNV

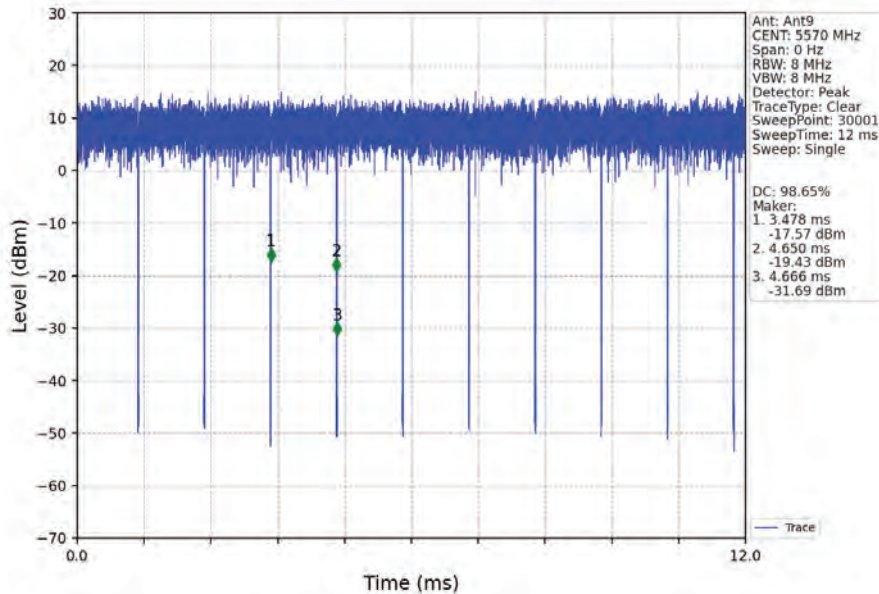

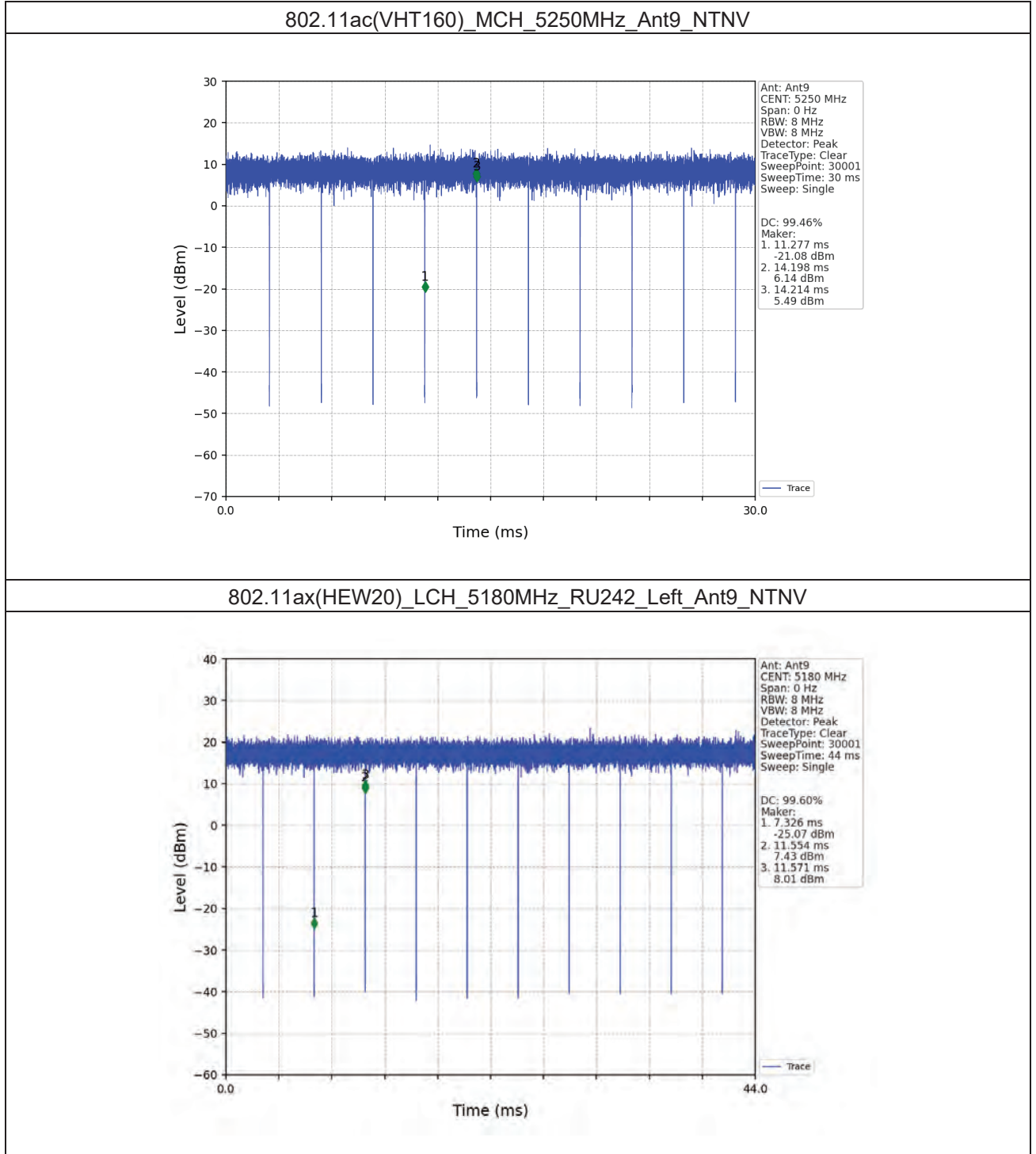

Unless otherwise agreed in writing, this document is issued by the Company subject to its General Conditions of Service printed overleaf, available on request or accessible at <https://www.sgs.com/en/Terms-and-Conditions>. Attention is drawn to the limitation of liability, indemnification and jurisdiction issues defined therein. Any holder of this document is advised that information contained hereon reflects the Company's findings at the time of its intervention only and within the limits of Client's instructions, if any. The Company's sole responsibility is to its Client and this document does not exonerate parties to a transaction from exercising all their rights and obligations under the transaction documents. This document cannot be reproduced except in full, without prior written approval of the Company. Any unauthorized alteration, forgery or falsification of the content or appearance of this document is unlawful and offenders may be prosecuted to the fullest extent of the law. Unless otherwise stated the results shown in this test report refer only to the sample(s) tested and such sample(s) are retained for 30 days only.

802.11ax(HEW20)_MCH_5200MHz_RU242_Left_Ant9_NTNV

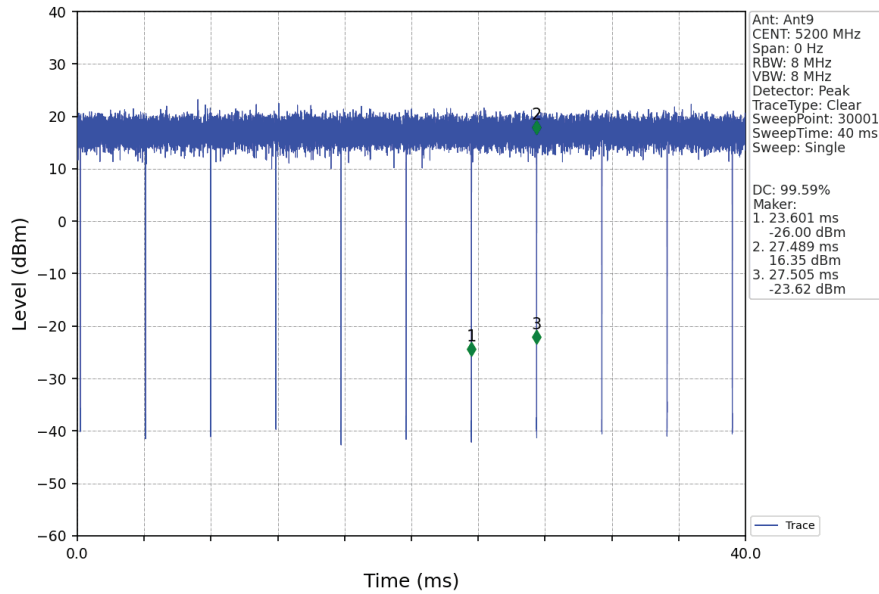

802.11ax(HEW20)_HCH_5240MHz_RU242_Left_Ant9_NTNV

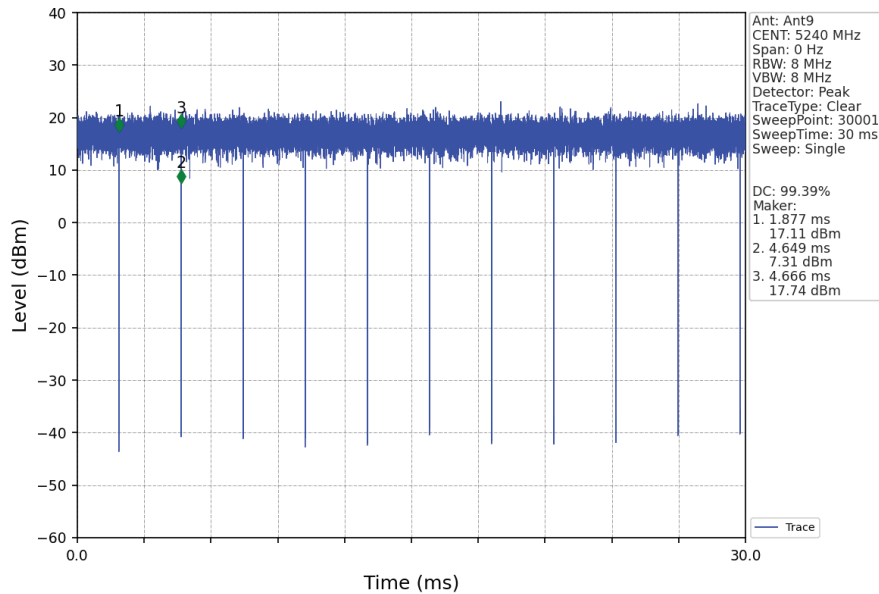

802.11ax(HEW20)_LCH_5260MHz_RU242_Left_Ant9_NTNV

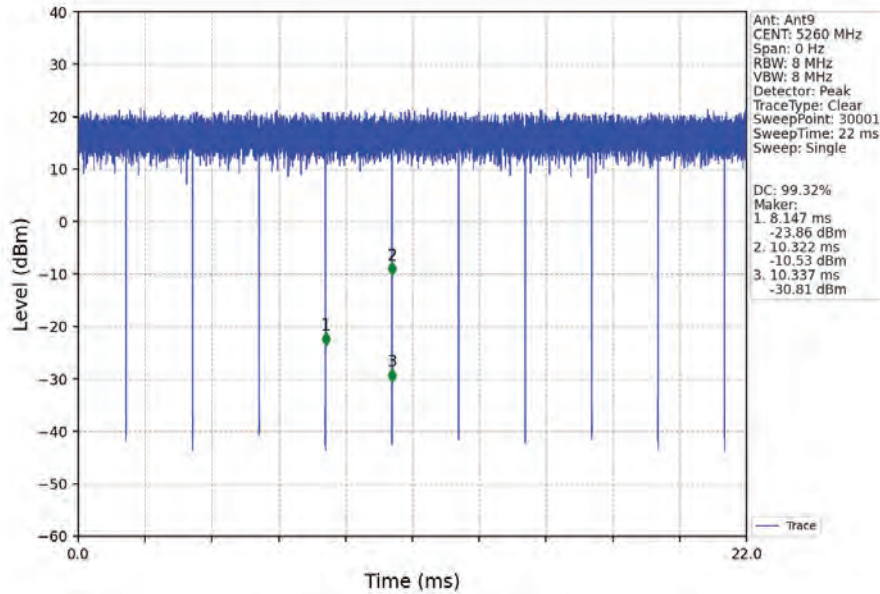

802.11ax(HEW20)_MCH_5300MHz_RU242_Left_Ant9_NTNV

