



TEST REPORT

Test Report No. : UL-RPT-RP13059547-316A V3.0

Customer : Neontri Sp. z.o.o. Sp. K.
PMN : Jiffee Dongle Desktop
HVIN : 1.2
FCC ID : 2AUQO-DESK001
ISED Certification No. : IC: 25534-DESK001
Technology : *Bluetooth* – Low Energy
Test Standard(s) : FCC Parts 15.207, 15.209(a) & 15.247
ISED Canada RSS-247 Issue 2 & RSS-Gen Issue 5
Test Laboratory : UL VS LTD, Basingstoke, Hampshire, RG24 8AH, United Kingdom

1. This test report shall not be reproduced except in full, without the written approval of UL VS LTD.
2. The results in this report apply only to the sample(s) tested.
3. The sample tested is in compliance with the above standard(s).
4. The test results in this report are traceable to the national or international standards.
5. Version 3.0 supersedes all previous versions.

Date of Issue: 18 December 2019

Checked by:

Ben Mercer
Senior Test Engineer, Radio Laboratory

Company Signatory:

Sarah Williams
Senior Test Engineer, Radio Laboratory
UL VS LTD



The *Bluetooth*[®] word mark and logos are owned by the *Bluetooth* SIG, Inc. and any use of such marks by UL VS LTD is under licence. Other trademarks and trade names are those of their respective owners.

UL VS LTD

Unit 1-3 Horizon, Kingsland Business Park, Wade Road, Basingstoke, Hampshire, RG24 8AH, UK
Telephone: +44 (0)1256 312000
Facsimile: +44 (0)1256 312001

Customer Information

Company Name:	Neontri Sp. z.o.o. Sp. K.
Address:	Puławska 2 Warszawa 02-566 Poland

Report Revision History

Version Number	Issue Date	Revision Details	Revised By
1.0	05/12/19	Initial Version	Ben Mercer
2.0	13/12/19	Admin update	Sarah Williams
3.0	18/12/19	Admin update	Sarah Williams

Table of Contents

Customer Information.....	2
Report Revision History	2
Table of Contents.....	3
1. Attestation of Test Results.....	4
1.1. Description of EUT	4
1.2. General Information	4
1.3. Summary of Test Results	5
1.4. Deviations from the Test Specification	5
2. Summary of Testing.....	6
2.1. Facilities and Accreditation	6
2.2. Methods and Procedures	6
2.3. Calibration and Uncertainty	7
2.4. Test and Measurement Equipment	8
3. Equipment Under Test (EUT)	10
3.1. Identification of Equipment Under Test (EUT)	10
3.2. Modifications Incorporated in the EUT	10
3.3. Additional Information Related to Testing	11
3.4. Description of Available Antennas	11
3.5. Description of Test Setup	12
4. Antenna Port Test Results	16
4.1. Transmitter 99% Occupied Bandwidth	16
4.2. Transmitter Minimum 6 dB Bandwidth	18
4.3. Transmitter Duty Cycle	20
4.4. Transmitter Maximum Peak Output Power	21
5. Radiated Test Results.....	24
5.1. Transmitter Radiated Emissions <1 GHz	24
5.2. Transmitter Radiated Emissions >1 GHz	26
5.3. Transmitter Band Edge Radiated Emissions	28
6. AC Power Line Conducted Emissions Test Results.....	31
6.1. Transmitter AC Conducted Spurious Emissions	31

1. Attestation of Test Results









1.1. Description of EUT

The equipment under test was a Point of Sale (POS) Device using Bluetooth Low Energy radio communication.

1.2. General Information

Specification Reference:	47CFR15.247
Specification Title:	Code of Federal Regulations Volume 47 (Telecommunications): Part 15 Subpart C (Intentional Radiators) – Section 15.247
Specification Reference:	47CFR15.207 and 47CFR15.209
Specification Title:	Code of Federal Regulations Volume 47 (Telecommunications): Part 15 Subpart C (Intentional Radiators) – Sections 15.207 and 15.209
Specification Reference:	RSS-Gen Issue 5 March 2019
Specification Title:	General Requirements for Compliance of Radio Apparatus
Specification Reference:	RSS-247 Issue 2 February 2017
Specification Title:	Digital Transmission Systems (DTSSs), Frequency Hopping Systems (FHSs) and Licence-Exempt Local Area Network (LE-LAN) Devices
Site Registration:	FCC: 621311 ISED Canada: 3245B
Location of Testing:	UL VS LTD, Unit 3 Horizon, Wade Road, Kingsland Business Park, Basingstoke, Hampshire, G24 8AH, United Kingdom
Test Dates:	18 November 2019 to 21 November 2019

1.3. Summary of Test Results

FCC Reference (47CFR)	ISED Canada Reference	Measurement	Result
-	RSS-Gen 6.7	Transmitter 99% Occupied Bandwidth	
Part 15.247(a)(2)	RSS-Gen 6.7 / RSS-247 5.2(a)	Transmitter Minimum 6 dB Bandwidth	
Part 15.35(c)	RSS-Gen 8.2	Transmitter Duty Cycle	Note 1
Part 15.247(b)(3)	RSS-Gen 6.12 / RSS-247 5.4(d)	Transmitter Maximum Peak Output Power	
Part 15.247(e)	RSS-247 5.2(b)	Transmitter Power Spectral Density	Note 2
Part 15.247(d) / 15.209(a)	RSS-Gen 6.13 & 8.9 / RSS-247 5.5	Transmitter Radiated Emissions	
Part 15.247(d) / 15.209(a)	RSS-Gen 6.13, 8.9 & 8.10 / RSS-247 5.5	Transmitter Band Edge Radiated Emissions	
Part 15.207	RSS-Gen 8.8	Transmitter AC Conducted Emissions	
Key to Results			
 = Complied  = Did not comply			

Note(s):

1. The measurement was performed to assist in the calculation of the level of average emissions. The EUT cannot transmit continuously and sweep triggering/signal gating cannot be implemented.
2. In accordance with ANSI C63.10 Section 11.10.1, PSD measurements are not required if the maximum conducted output power is less than the PSD limit of 8 dBm / 3 kHz. The PSD level is therefore deemed to be equal to the measured output power.

1.4. Deviations from the Test Specification

For the measurements contained within this test report, there were no deviations from, additions to, or exclusions from the test specification identified above.

2. Summary of Testing

2.1. Facilities and Accreditation

The test site and measurement facilities used to collect data are located at Unit 3 Horizon, Wade Road, Kingsland Business Park, Basingstoke, Hampshire, RG24 8AH, United Kingdom. The following table identifies which facilities were utilised for radiated emission measurements documented in this report. Specific facilities are also identified in the test results sections.

Site 1	-
Site 2	-
Site 17	X

UL VS LTD is accredited by UKAS. The tests reported herein have been performed in accordance with its terms of accreditation.

2.2. Methods and Procedures

Reference:	ANSI C63.10-2013
Title:	American National Standard of Procedures for Compliance Testing of Unlicensed Wireless Devices
Reference:	KDB 558074 D01 15.247 Meas Guidance v05r02, April 2, 2019
Title:	Guidance for Compliance Measurements on Digital Transmission System, Frequency Hopping Spread Spectrum System, and Hybrid System Devices Operating Under Section 15.247 of the FCC Rules
Reference:	KDB 174176 D01 Line Conducted FAQ v01r01 June 3, 2015
Title:	AC Power-Line Conducted Emissions Frequently Asked Questions

2.3. Calibration and Uncertainty

Measuring Instrument Calibration

In accordance with UKAS requirements all the measurement equipment is on a calibration schedule. All equipment was within the calibration period on the date of testing.

Measurement Uncertainty

No measurement or test can ever be perfect and the imperfections give rise to error of measurement in the results. Consequently the result of a measurement is only an approximation to the value measured (the specific quantity subject to measurement) and is only complete when accompanied by a statement of the uncertainty of the approximation.

The expression of uncertainty of a measurement result allows realistic comparison of results with reference values and limits given in specifications and standards.

The uncertainty of the result may need to be taken into account when interpreting the measurement results.

The reported expanded uncertainties below are based on a standard uncertainty multiplied by an appropriate coverage factor such that a confidence level of approximately 95% is maintained. For the purposes of this document "approximately" is interpreted as meaning "effectively" or "for most practical purposes".

Measurement Type	Range	Confidence Level (%)	Calculated Uncertainty
99% Occupied Bandwidth	2.4 GHz to 2.4835 GHz	95%	±3.92 %
Minimum 6 dB Bandwidth	2.4 GHz to 2.4835 GHz	95%	±4.59 %
Duty Cycle	2.4 GHz to 2.4835 GHz	95%	±1.14 %
Spectral Power Density	2.4 GHz to 2.4835 GHz	95%	±2.94 dB
Conducted Maximum Peak Output Power	2.4 GHz to 2.4835 GHz	95%	±1.13 dB
Radiated Spurious Emissions	30 MHz to 1 GHz	95%	±3.30 dB
Radiated Spurious Emissions	1 GHz to 25 GHz	95%	±2.94 dB
AC Conducted Spurious Emissions	0.15 MHz to 30 MHz	95%	±1.96 dB

The methods used to calculate the above uncertainties are in line with those recommended within the various measurement specifications. Where measurement specifications do not include guidelines for the evaluation of measurement uncertainty the published guidance of the appropriate accreditation body is followed.

2.4. Test and Measurement Equipment

Test Equipment Used for Transmitter Conducted Tests

Asset No.	Instrument	Manufacturer	Type No.	Serial No.	Date Calibration Due	Cal. Interval (Months)
M2001	Thermohygrometer	Testo	608-H1	45041824	06 Jan 2020	12
M1996	Signal Analyser	Rohde & Schwarz	FSV13	100975	16 Jan 2020	12
G0615	Vector Signal Generator	Rohde & Schwarz	SMBV100A	260473	08 May 2020	36
A2525	Attenuator	AtlanTecRF	AN18W5-10	832827-3#	Calibrated before use	-

Test Equipment Used for Transmitter Radiated Emissions Tests

Asset No.	Instrument	Manufacturer	Type No.	Serial No.	Date Calibration Due	Cal. Interval (Months)
K0017	3m RSE Chamber	Rainford	N/A	N/A	01 Aug 2020	12
M1995	Test Receiver	Rohde & Schwarz	ESU40	100428	08 May 2020	12
M2003	Thermohygrometer	Testo	608-H1	45046641	06 Jan 2020	12
A2863	Pre Amplifier	Agilent	8449B	3008A02100	08 Aug 2020	12
A2892	Antenna	Schwarzbeck	BBV 9170	9170-727	01 Aug 2020	12
A2893	Pre Amplifier	Schwarzbeck	BBV 9721	9721-021	31 Jul 2020	12
A2914	High Pass Filter	AtlanTecRF	AFH-03000	2155	20 Feb 2020	12
A2916	Attenuator	AtlanTecRF	AN18W5-10	832827#1	20 Feb 2020	12
A2947	High Pass Filter	AtlanTecRF	AFH-07000	1601900001	20 Feb 2020	12
A3142	Pre Amplifier	Schwarzbeck	BBV 9718 B	00020	08 Aug 2020	12
A490	Antenna	Chase	CBL6111A	1590	21 May 2020	12
A2889	Antenna	Schwarzbeck	BBHA 9120 B	BBHA 9120B653	12 Feb 2020	12
A2890	Antenna	Schwarzbeck	HWRD 750	014	08 Aug 2020	12

Test Equipment Used for Transmitter Band Edge Radiated Emissions Tests

Asset No.	Instrument	Manufacturer	Type No.	Serial No.	Date Calibration Due	Cal. Interval (Months)
K0017	3m RSE Chamber	Rainford	N/A	N/A	16 Feb 2020	12
M2003	Thermohygrometer	Testo	608-H1	45046641	06 Jan 2020	12
M1995	Test Receiver	Rohde & Schwarz	ESU40	100428	08 May 2020	12
A2863	Pre-Amplifier	Agilent	8449B	3008A02100	12 Feb 2020	12
A2916	Attenuator	AtlanTecRF	AN18W5-10	832827#1	20 Feb 2020	12
A2889	Antenna	Schwarzbeck	BBHA 9120 B	BBHA 9120 B 653	12 Feb 2020	12

Test and Measurement Equipment (continued)**Test Equipment Used for Transmitter AC Conducted Spurious Emissions:**

Asset No.	Instrument	Manufacturer	Type No.	Serial No.	Date Calibration Due	Cal. Interval (Months)
M2037	Thermohygrometer	Testo	608-H1	45124925	06 Jan 2020	12
A649	LISN	Rohde & Schwarz	ESH3-Z5	825562/008	08 Aug 2020	12
A1830	Pulse Limiter	Rohde & Schwarz	ESH3-Z2	100668	10 Apr 2020	12
M1273	Test Receiver	Rohde & Schwarz	ESIB 26	100275	18 Dec 2019	12

Test Measurement Software/Firmware Used:

Name	Version	Release Date
Rohde & Schwarz EMC32	6.30.0	2008

3. Equipment Under Test (EUT)

3.1. Identification of Equipment Under Test (EUT)

Brand Name:	Jiffee Dongle
PMN:	Jiffee Dongle Desktop
Test Sample Serial Number:	Not marked or stated (<i>Conducted sample #1</i>)
Hardware Version / HVIN:	1.2
Software Version:	0.9.0.0
FCC ID:	2AUQO-DESK001
ISED Certification No.	IC: 25534-DESK001

Brand Name:	Jiffee Dongle
PMN:	Jiffee Dongle Desktop
Test Sample Serial Number:	Not marked or stated (<i>Radiated sample #1</i>)
Hardware Version / HVIN:	1.2
Software Version:	0.9.0.0
FCC ID:	2AUQO-DESK001
ISED Certification No.	IC: 25534-DESK001

3.2. Modifications Incorporated in the EUT

No modifications were applied to the EUT during testing.

3.3. Additional Information Related to Testing

Technology Tested:	<i>Bluetooth</i> Low Energy (Digital Transmission System)		
Type of Unit:	Transceiver		
Channel Spacing:	2 MHz		
Modulation:	GFSK		
Data Rate: LE	1 Mbps		
Power Supply Requirement(s):	Nominal	5 VDC	
Maximum Conducted Output Power:	-1.4 dBm		
Transmit Frequency Range:	2402 MHz to 2480 MHz		
Transmit Channels Tested:	Channel ID	Channel Number	Channel Frequency (MHz)
	Bottom	37	2402
	Middle	17	2440
	Top	39	2480

3.4. Description of Available Antennas

The radio utilizes an integrated antenna, with the following maximum gain:

Frequency Range (MHz)	Antenna Gain (dBi)
2400-2480	3.5

3.5. Description of Test Setup

Support Equipment

The following support equipment was used to exercise the EUT during testing:

Description:	Laptop PC
Brand Name:	Lenovo
Model Name or Number:	ThinkPad L480
Serial Number:	PF1EHZQ0

Description:	USB Type A to USB Type C cable . Length 1m. Quantity 2
Brand Name:	Not marked or stated
Model Name or Number:	Not marked or stated
Serial Number:	Not marked or stated

Description:	Laptop PC
Brand Name:	Lenovo
Model Name or Number:	ThinkPad L480
Serial Number:	PF1EHZQQ

Description:	Laptop Power Supply
Brand Name:	Lenovo
Model Name or Number:	ADLX65YCC3A
Serial Number:	8SSA10M13950C1SG894034W

Description:	AC Adapter
Brand Name:	Huawei
Model Name or Number:	HW-050100E2W
Serial Number:	H439K3F9P00808

Operating Modes

The EUT was tested in the following operating mode(s):

- Transmitting at maximum power in *Bluetooth* LE mode with modulation, maximum possible data length available and Pseudorandom Bit Sequence 9.

Configuration and Peripherals

The EUT was tested in the following configuration(s):

- Controlled in test mode using a customer supplied software application on a laptop PC. The application was used to enable a continuous transmission and to select the test channels as required. The customer supplied a document containing the setup instructions 'DTM_eng.pdf'. The laptop PC was connected to the EUT via a USB Type A to USB Type C Cable.
- The EUT was powered via the USB Type A to USB Type C cable connected to the laptop PC.
- Transmitter radiated spurious emissions tests were performed with the EUT in the Y plane (worst case) while connected to the laptop PC. There were no other active ports to terminate.
- AC conducted tests were performed with the EUT transmitting in Bluetooth LE mode while powered from an AC charger and laptop PC. Final measurements were performed using the laptop PC.

Test Setup Diagrams

Conducted Tests:

Test Setup for Transmitter Minimum 6 dB Bandwidth, Duty Cycle, Power Spectral Density & Maximum Peak Output Power

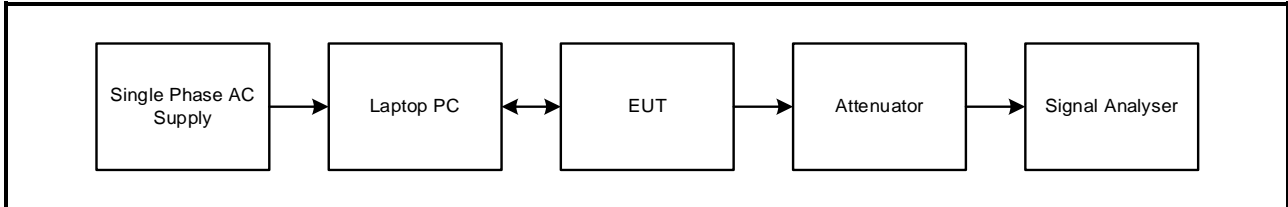

Radiated Tests:

Test Setup for Transmitter Radiated Emissions

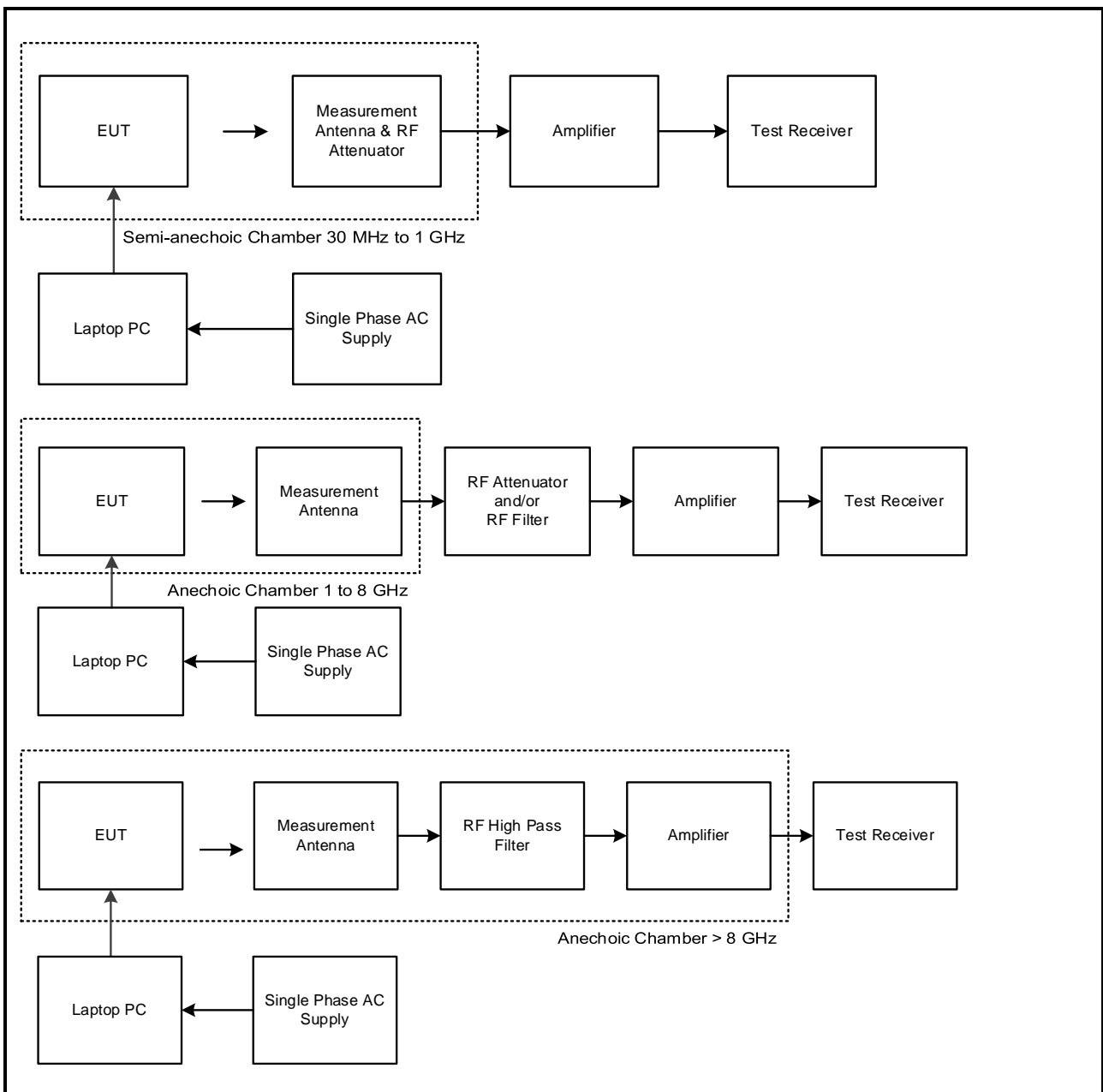

Test Setup Diagrams (continued)

Test Setup for Transmitter AC Conducted Spurious Emissions

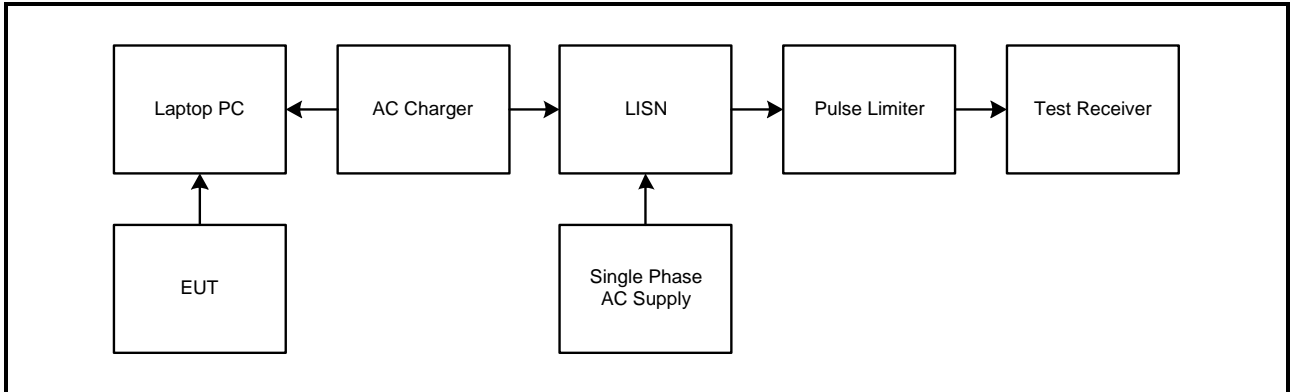

4. Antenna Port Test Results

4.1. Transmitter 99% Occupied Bandwidth

Test Summary:

Test Engineer:	Matthew Botfield	Test Date:	18 November 2019
Test Sample Serial Number:	Not marked or stated (<i>Conducted sample #1</i>)		

ISED Canada Reference:	RSS-Gen 6.7
Test Method Used:	RSS-Gen 6.7 and Notes below

Environmental Conditions:

Temperature (°C):	19
Relative Humidity (%):	47

Note(s):

1. The 99% emission bandwidth was measured using the signal analyser occupied bandwidth function. The resolution bandwidth was set in the range of 1% to 5% of the occupied bandwidth and the video bandwidth set to 3 times the resolution bandwidth. The span was set to capture all products of the modulation process including emission skirts.
2. The signal analyser was connected to the RF port on the EUT using suitable attenuation and RF cable.

Transmitter 99% Occupied Bandwidth (continued)

Results:

Channel	99% Occupied Bandwidth (kHz)
Bottom	1053.546
Middle	1053.546
Top	1035.546

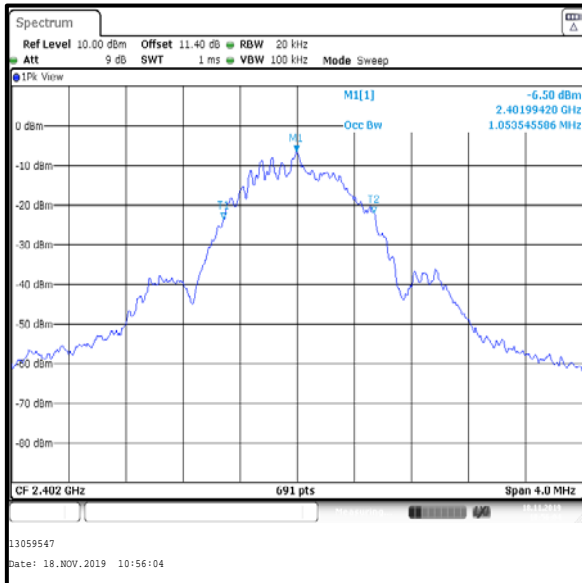

Bottom Channel

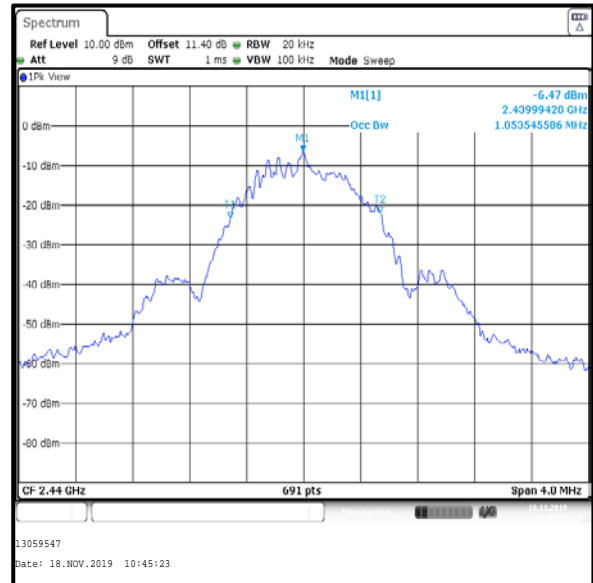

Middle Channel

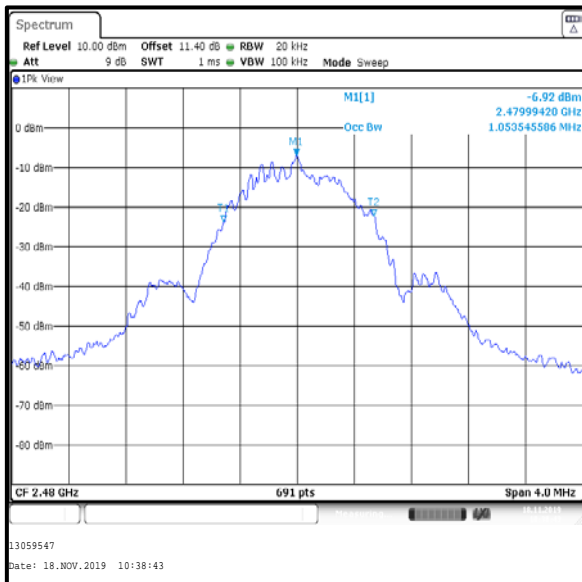

Top Channel

4.2. Transmitter Minimum 6 dB Bandwidth**Test Summary:**

Test Engineer:	Matthew Botfield	Test Date:	18 November 2019
Test Sample Serial Number:	Not marked or stated (<i>Conducted sample #1</i>)		

FCC Reference:	Part 15.247(a)(2)
ISED Canada Reference:	RSS-Gen 6.7 / RSS-247 5.2(a)
Test Method Used:	FCC KDB 558074 Section 8.2 referencing ANSI C63.10 Section 11.8.1

Environmental Conditions:

Temperature (°C):	19
Relative Humidity (%):	47

Note(s):

1. 6 dB DTS bandwidth tests were performed using a signal analyser in accordance with ANSI C63.10 Section 11.8.1 Option 1 measurement procedure. The signal analyser resolution bandwidth was set to 100 kHz and video bandwidth 300 kHz. A peak detector was used, sweep time was set to auto and the trace mode was Max Hold. The DTS bandwidth was measured at 6 dB down from the peak of the signal.
2. The signal analyser was connected to the RF port on the EUT using suitable attenuation and RF cable.

Transmitter Minimum 6 dB Bandwidth (continued)

Results:

Channel	6 dB Bandwidth (kHz)	Limit (kHz)	Margin (kHz)	Result
Bottom	706.200	≥500	206.200	Complied
Middle	712.000	≥500	212.000	Complied
Top	706.200	≥500	206.200	Complied

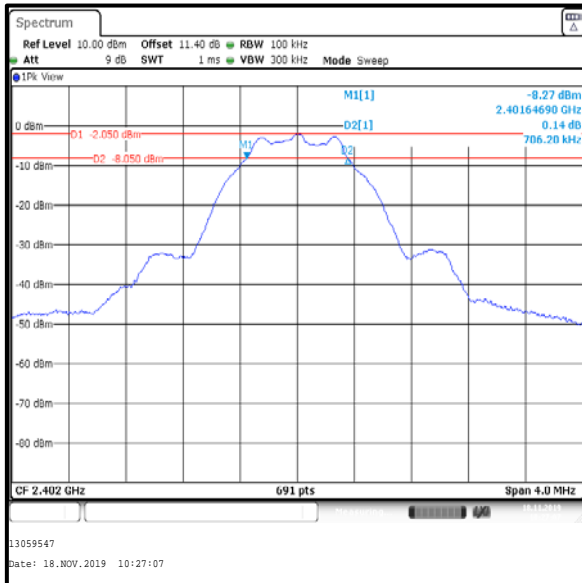

Bottom Channel

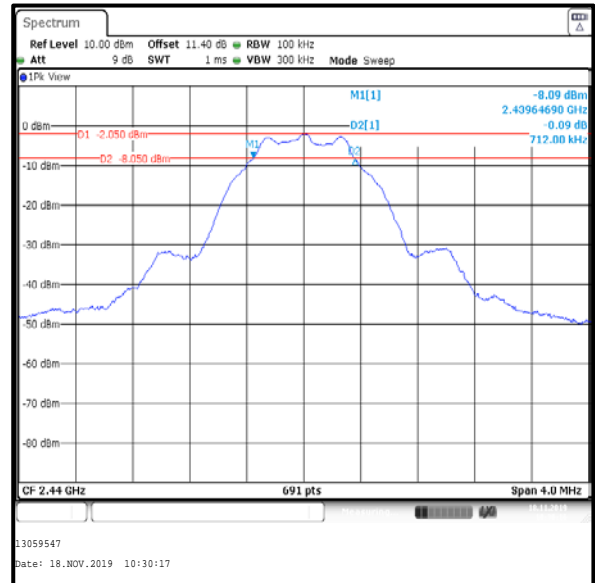

Middle Channel

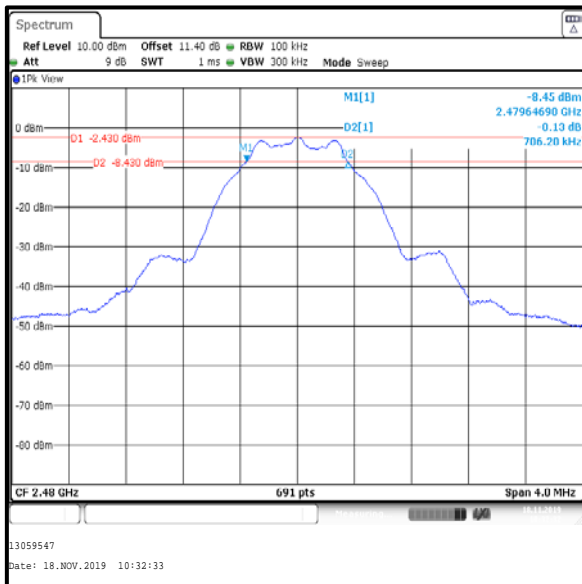

Top Channel

4.3. Transmitter Duty Cycle

Test Summary:

Test Engineer:	Matthew Botfield	Test Date:	18 November 2019
Test Sample Serial Number:	Not marked or stated (Conducted sample #1)		

FCC Reference:	Part 15.35(c)
ISED Canada Reference:	RSS-Gen 8.2
Test Method Used:	FCC KDB 558074 Section 6 referencing ANSI C63.10 Section 11.6

Environmental Conditions:

Temperature (°C):	19
Relative Humidity (%):	47

Note(s):

- In order to assist with the determination of the average level of spurious emissions field strength mode, measurements were made of duty cycle to determine the transmission duration and the silent period time of the transmitter. The transmitter duty cycle was measured using a spectrum/signal analyser in the time domain and calculated by using the following calculation:

$$10 \log (1 / (\text{On Time} / [\text{Period or } 100 \text{ ms whichever is the lesser}])).$$

$$LE \text{ duty cycle: } 10 \log (1 / (389.938 \mu\text{s} / 625.000 \mu\text{s})) = 2.0 \text{ dB}$$

Results:

Pulse Duration (µs)	Period (µs)	Duty Cycle (dB)
389.938	625.000	2.0

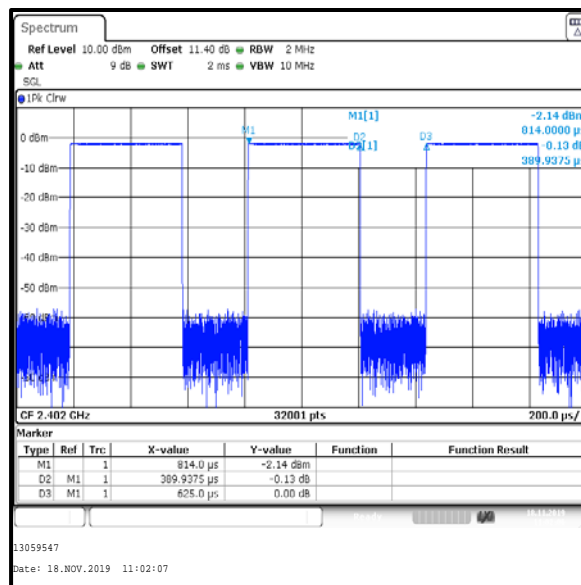

4.4. Transmitter Maximum Peak Output Power

Test Summary:

Test Engineer:	Matthew Botfield	Test Date:	18 November 2019
Test Sample Serial Number:	Not marked or stated (<i>Conducted sample #1</i>)		

FCC Reference:	Part 15.247(b)(3)
ISED Canada Reference:	RSS-Gen 6.12 / RSS-247 5.4(d)
Test Method Used:	FCC KDB 558074 Section 8.3.1.1 referencing ANSI C63.10 Section 11.9.1.1 and Notes below

Environmental Conditions:

Temperature (°C):	19
Relative Humidity (%):	47

Note(s):

1. Conducted power tests were performed using a signal analyser in accordance with ANSI C63.10 Section 11.9.1.1 with the RBW \geq DTS bandwidth procedure.
2. The signal analyser resolution bandwidth was set to 1 MHz and video bandwidth of 3 MHz. A peak detector was used, sweep time was set to auto and trace mode was Max Hold. The span was set to 3 MHz. A marker was placed at the peak of the signal and the results recorded in the tables below.
3. The signal analyser was connected to the RF port on the EUT using suitable attenuation and RF cable. An RF level offset was entered on the signal analyser to compensate for the loss of the attenuator and RF cable.
4. The conducted power was added to the declared antenna gain to obtain the EIRP.

Transmitter Maximum Peak Output Power (continued)**Results:**

Channel	Conducted Peak Power (dBm)	Conducted Peak Power Limit (dBm)	Margin (dB)	Result
Bottom	-1.4	30.0	31.4	Complied
Middle	-1.4	30.0	31.4	Complied
Top	-1.8	30.0	31.8	Complied

Channel	Conducted Peak Power (dBm)	Declared Antenna Gain (dBi)	EIRP (dBm)	De Facto EIRP Limit (dBm)	Margin (dB)	Result
Bottom	-1.4	3.5	2.1	36.0	33.9	Complied
Middle	-1.4	3.5	2.1	36.0	33.9	Complied
Top	-1.8	3.5	1.7	36.0	34.3	Complied

Transmitter Maximum Peak Output Power (continued)

Results:

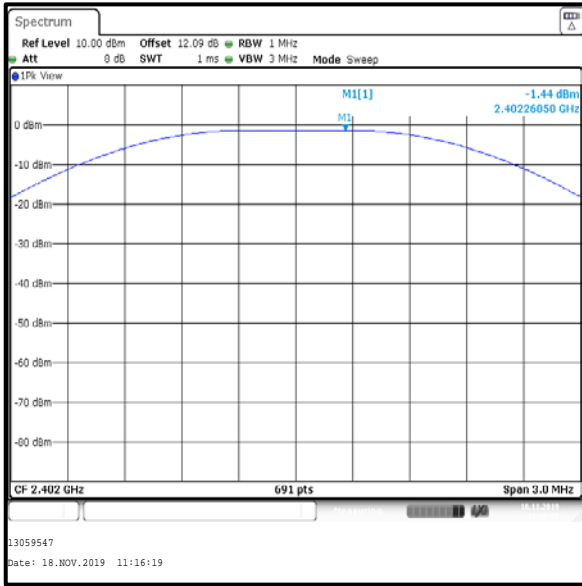

Bottom Channel

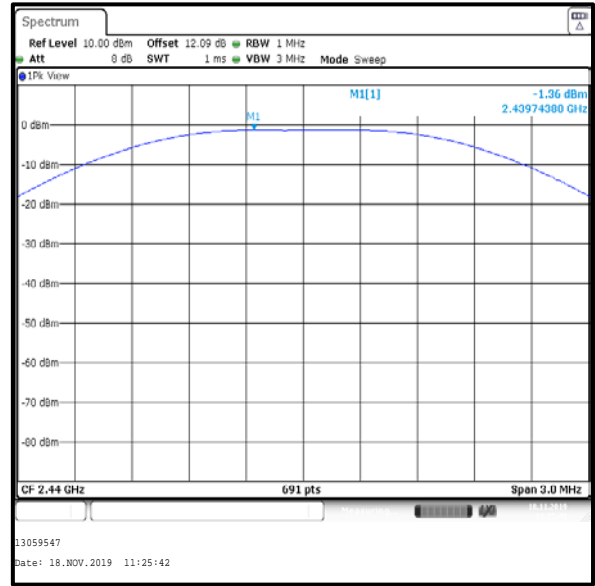

Middle Channel

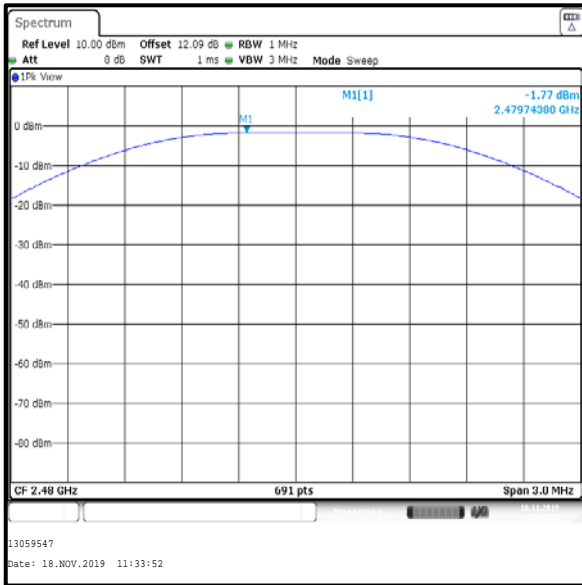

Top Channel

5. Radiated Test Results

5.1. Transmitter Radiated Emissions <1 GHz

Test Summary:

Test Engineer:	John Ferdinand	Test Date:	19 November 2019
Test Sample Serial Number:	Not marked or stated (<i>Radiated sample #1</i>)		

FCC Reference:	Parts 15.247(d) & 15.209(a)
ISED Canada Reference:	RSS-Gen 6.13 & 8.9 / RSS-247 5.5
Test Method Used:	ANSI C63.10 Sections 6.3 and 6.5
Frequency Range	30 MHz to 1000 MHz

Environmental Conditions:

Temperature (°C):	23
Relative Humidity (%):	38

Note(s):

1. The final measured value, for the given emission, in the table below incorporates the calibrated antenna factor and cable loss.
2. The preliminary scans showed similar emission levels below 1 GHz, for each channel of operation. Therefore final radiated emissions measurements were performed with the EUT set to the middle channel only.
3. Measurements below 1 GHz were performed in a semi-anechoic chamber (Asset Number K0017) at a distance of 3 metres. The EUT was placed at a height of 80 cm above the reference ground plane in the centre of the chamber turntable. Maximum emission levels were determined by height searching the measurement antenna over the range 1 metre to 4 metres.
4. Pre-scans were performed and markers placed on the highest measured levels. The test receiver resolution bandwidth was set to 120 kHz and video bandwidth 500 kHz. A peak detector was used, sweep time was set to auto and trace mode was Max Hold.
5. Final measurements were performed on the marker frequencies and the results entered into the table below. The test receiver resolution bandwidth was set to 120 kHz, using a CISPR quasi-peak detector and span wide enough to see the whole emission.

Transmitter Radiated Emissions (continued)

Results: Quasi-Peak / Middle Channel

Frequency (MHz)	Antenna Polarity	Level (dB μ V/m)	Limit (dB μ V/m)	Margin (dB)	Result
73.411	Vertical	19.2	40.0	20.8	Complied
75.200	Vertical	18.7	40.0	21.3	Complied
120.206	Vertical	22.8	43.5	20.7	Complied
149.900	Vertical	19.4	43.5	24.1	Complied
240.000	Vertical	20.8	46.0	25.2	Complied

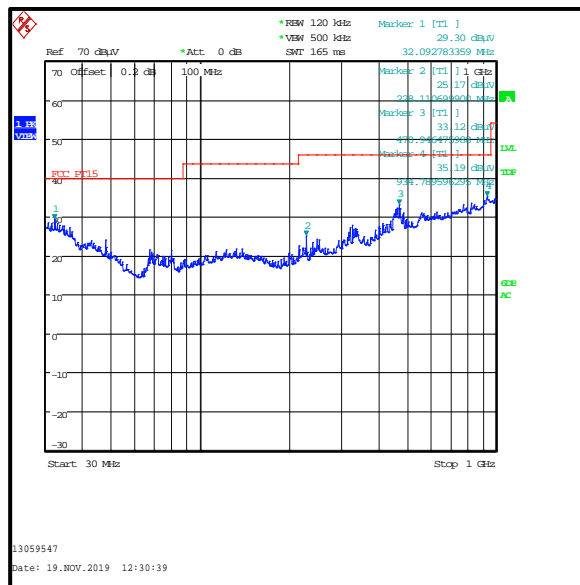

Note: This plot is a pre-scan and for indication purposes only. For final measurements, see accompanying table.

5.2. Transmitter Radiated Emissions >1 GHz

Test Summary:

Test Engineer:	John Ferdinand	Test Dates:	18 November 2019 to 20 November 2019
Test Sample Serial Number:	Not marked or stated (<i>Radiated sample #1</i>)		

FCC Reference:	Parts 15.247(d) & 15.209(a)
ISED Canada Reference:	RSS-Gen 6.13 & 8.9 / RSS-247 5.5
Test Method Used:	FCC KDB 558074 Sections 8.1 c)3), 8.5 & 8.6 referencing ANSI C63.10 Sections 6.3, 6.6, 11.11 & 11.12
Frequency Range	1 GHz to 25 GHz

Environmental Conditions:

Temperature (°C):	22 to 23
Relative Humidity (%):	37 to 43

Note(s):

1. The final measured value, for the given emission, in the table below incorporates the calibrated antenna factor and cable loss.
2. No spurious emissions were detected above the noise floor of the measuring receiver, therefore the highest peak and average noise floor readings of the measuring receiver were recorded as shown in the tables below.
3. The emission shown on the 1 GHz to 3 GHz plot is the EUT fundamental at 2440 MHz.
4. *In accordance with ANSI C63.10 Section 6.6.4.3 (Note 1), if the peak measured value complies with the average limit, it is unnecessary to perform an average measurement.
5. Pre-scan and final measurements above 1 GHz were performed in a fully anechoic chamber (Asset Number K0017) at a distance of 3 metres. The EUT was placed at a height of 1.5 m above the reference ground plane in the centre of the chamber turntable. Maximum emission levels were determined by height searching the measurement antenna over the range 1 metre to 4 metres.
6. Pre-scans were performed and a marker placed on the highest measured level of the appropriate plot. The test receiver resolution bandwidth was set to 1 MHz and video bandwidth 3 MHz. The sweep time was set to auto. Peak and average measurements were performed with their own appropriate detectors during the pre-scan measurements.

Transmitter Radiated Emissions (continued)

Results: Peak / Middle Channel

Frequency (MHz)	Antenna Polarity	Level (dBμV/m)	Limit (dBμV/m)	Margin (dB)	Result
2823.500	Vertical	55.1	74.0	19.9	Complied

Results: Average / Middle Channel

Frequency (MHz)	Antenna Polarity	Level (dBμV/m)	Limit (dBμV/m)	Margin (dB)	Result
2880.000	Vertical	48.2	54.0	5.8	Complied

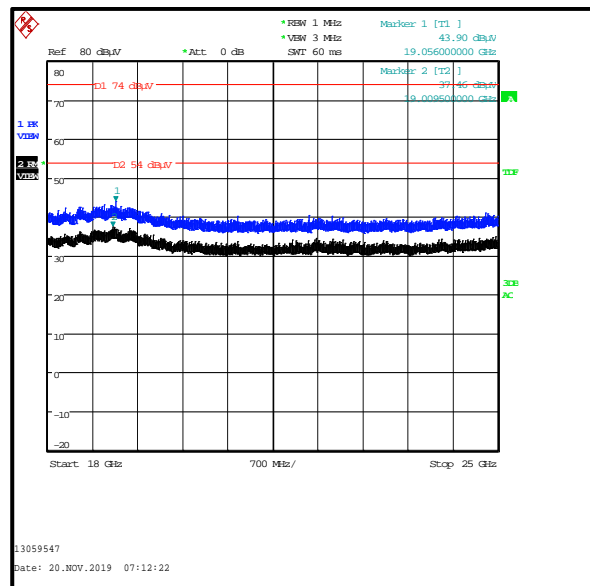
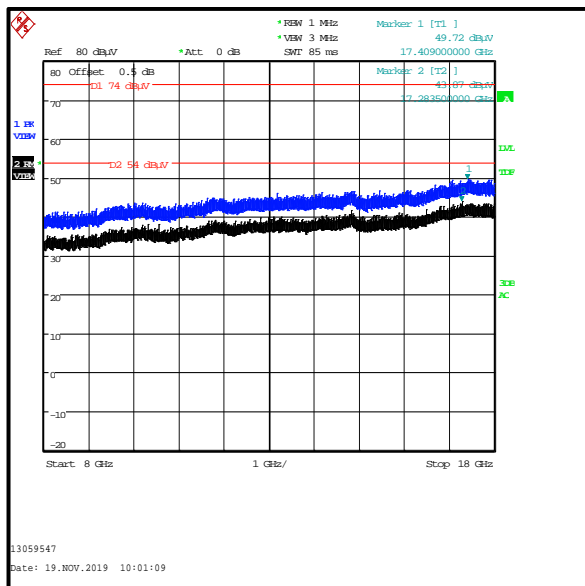
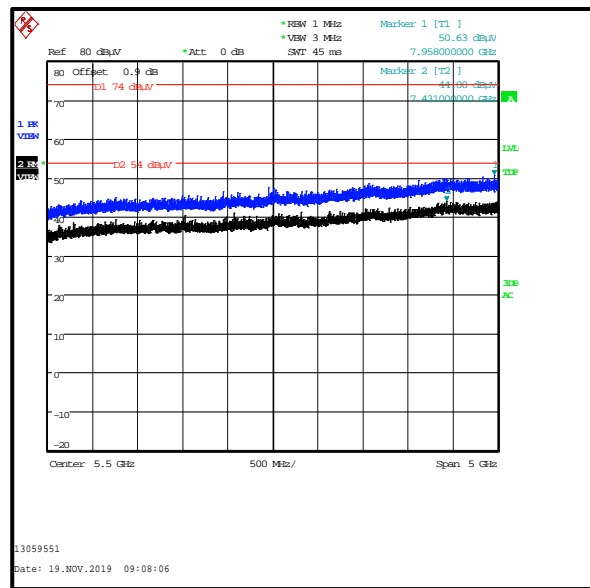
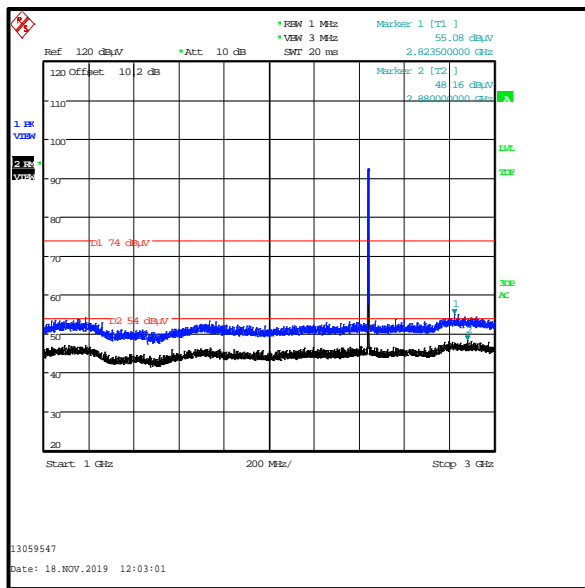

Note: These plots are pre-scans and for indication purposes only. For final measurements, see accompanying tables.

5.3. Transmitter Band Edge Radiated Emissions

Test Summary:

Test Engineer:	John Ferdinand	Test Date:	18 November 2019
Test Sample Serial Number:	Not marked or stated (<i>Radiated sample #1</i>)		

FCC Reference:	Parts 15.247(d) & 15.209(a)
ISED Canada Reference:	RSS-Gen 6.13, 8.9 & 8.10 / RSS-247 5.5
Test Method Used:	KDB 558074 Section 8.7 referencing ANSI C63.10 Sections 11.11, 11.12 & 11.13

Environmental Conditions:

Temperature (°C):	22
Relative Humidity (%):	37

Note(s):

1. The final measured value, for the given emission, in the table below incorporates the calibrated antenna factor and cable loss.
2. As the lower band edge is adjacent to a non-restricted band, only peak measurements are required. In accordance with ANSI C63.10 Section 11.11, the test method in Section 11.11.3 was followed: the test receiver resolution bandwidth was set to 100 kHz and video bandwidth 300 kHz. A peak detector was used, sweep time was set to auto and trace mode was Max Hold. The test receiver was left to sweep for a sufficient length of time in order to maximise the carrier level and out-of-band emissions. A marker and corresponding reference level line were placed on the peak of the carrier. As the maximum peak conducted output power was measured using an peak detector, an out-of-band limit line was placed 20 dB (ANSI C63.10 Subclause 11.11.1(a)) below the peak level. A marker was placed on the band edge spot frequencies. Marker frequency and levels were recorded.
3. As the upper band edge is adjacent to a restricted band, both peak and average measurements were recorded by placing a marker at the edge of the band. For peak measurements the test receiver resolution bandwidth was set to 1 MHz and the video bandwidth 3 MHz. A peak detector was used, sweep time was set to auto and trace mode was Max Hold. For average measurements the test receiver resolution bandwidth was set to 1 MHz and the video bandwidth 3 MHz. An RMS detector was used, sweep time was set to auto and trace mode was trace averaging over 300 sweeps. A marker was placed on the band edge spot frequencies and a second marker placed on the highest emission level in the adjacent restricted band of operation (where a higher level emission was present). Marker frequencies and levels were recorded.
4. There is a restricted band 10 MHz below the lower band edge. The test receiver was set up as follows: the RBW set to 1 MHz, the VBW set to 3 MHz, with the sweep time set to auto couple. Peak and average measurements were performed with peak and RMS detectors respectively. Markers were placed on the highest point on each trace.
5. * -20 dBc limit.
6. **As the EUT had a duty cycle < 98% the duty cycle correction factor has been applied to the upper band edge average result. The corrected level is shown below:

$$\text{Upper Band Average result} + \text{duty cycle} = \text{Corrected band edge level}$$

$$\text{Corrected band edge level at 2485.022 MHz} : 44.8 + 2.0 = 46.8 \text{ dB}\mu\text{V/m}$$

Transmitter Band Edge Radiated Emissions (continued)**Results: Peak**

Frequency (MHz)	Antenna Polarity	Level (dB μ V/m)	Limit (dB μ V/m)	Margin (dB)	Result
2400.000	Horizontal	45.8	71.2*	25.4	Complied
2483.500	Vertical	51.4	74.0	22.6	Complied
2483.821	Vertical	52.5	74.0	21.5	Complied

Results: Average

Frequency (MHz)	Antenna Polarity	Level (dB μ V/m)	Duty cycle correction (dB)	Corrected Level (dB μ V/m)	Limit (dB μ V/m)	Margin (dB)	Result
2483.500	Vertical	44.2	2.0	46.2	54.0	7.8	Complied
2485.022	Vertical	44.8	2.0	46.8	54.0	7.2	Complied

Results: 2310 MHz to 2390 MHz Restricted Band / Peak

Frequency (MHz)	Antenna Polarity	Level (dB μ V/m)	Limit (dB μ V/m)	Margin (dB)	Result
2358.077	Horizontal	53.2	74.0	20.8	Complied

Results: 2310 MHz to 2390 MHz Restricted Band / Average

Frequency (MHz)	Antenna Polarity	Level (dB μ V/m)	Limit (dB μ V/m)	Margin (dB)	Result
2389.615	Horizontal	41.0	54.0	13.0	Complied

Transmitter Band Edge Radiated Emissions (continued)

Results:

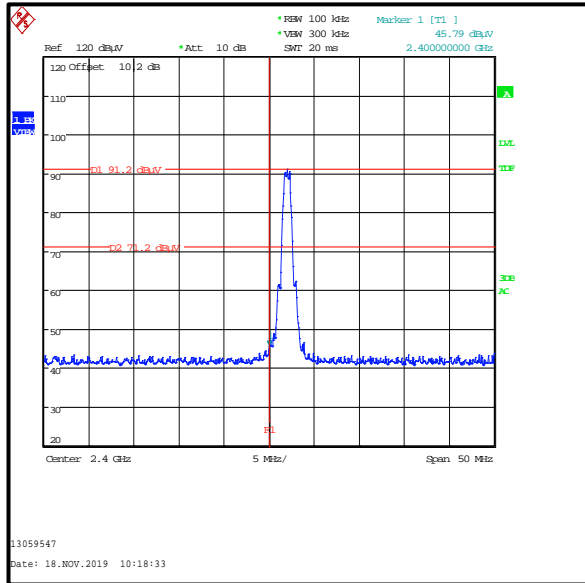

Lower Band Edge

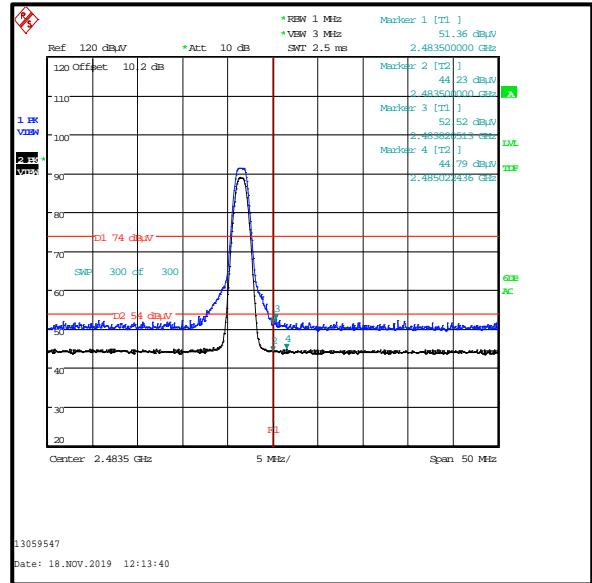

Upper Band Edge

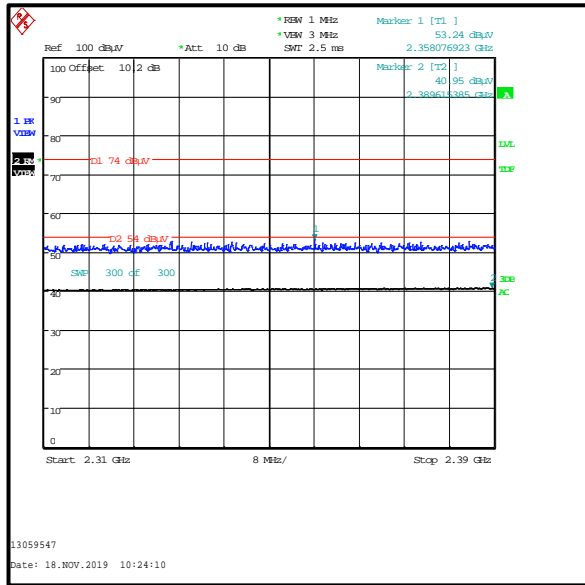

2310 MHz to 2390 MHz Restricted Band

6. AC Power Line Conducted Emissions Test Results

6.1. Transmitter AC Conducted Spurious Emissions

Test Summary:

Test Engineer:	Alison Johnston	Test Dates:	20 November 2019 & 21 November 2019
Test Sample Serial Number:	Not marked or stated (<i>Radiated sample #1</i>)		

FCC Reference:	Part 15.207
ISED Canada Reference:	RSS-Gen 8.8
Test Method Used:	ANSI C63.10 Section 6.2 / FCC KDB 174176 and notes below

Environmental Conditions:

Temperature (°C):	18
Relative Humidity (%):	42 to 43

Note(s):

1. The EUT was connected to a laptop PC via a USB cable. The laptop PC supplied the EUT with 5 VDC. The laptop PC power supply was connected to 120 VAC 60 Hz single phase supply via a LISN.
2. In accordance with FCC KDB 174176 Q4, tests were also performed with a 240 VAC 60 Hz single phase supply as this was within the voltage range marked on the Laptop power supply.
3. A pulse limiter was fitted between the LISN and the test receiver.
4. Pre-scans were performed and markers placed on the highest live and neutral measured levels. Final measurements were performed on the marker frequencies and the results entered into the tables below.
5. Pre-scans were performed with the EUT transmitting on middle channel.
6. Pre-scans were also performed with the EUT powered by an AC adapter. The worst case mode was found to be the EUT powered from the laptop PC. Final measurements were performed using this configuration. Pre-scan result plots for the AC charger are archived on the UL VS LTD IT server and available for inspection upon request.

Transmitter AC Conducted Spurious Emissions (continued)**Results: Live / Quasi Peak / 120 VAC 60 Hz**

Frequency (MHz)	Line	Level (dB μ V)	Limit (dB μ V)	Margin (dB)	Result
0.168000	Live	51.5	65.1	13.6	Complied
0.429000	Live	35.1	57.3	22.2	Complied
1.707000	Live	21.0	56.0	35.0	Complied
3.444000	Live	29.2	56.0	26.8	Complied
7.314000	Live	31.2	60.0	28.8	Complied
10.954500	Live	27.1	60.0	32.9	Complied

Results: Live / Average / 120 VAC 60 Hz

Frequency (MHz)	Line	Level (dB μ V)	Limit (dB μ V)	Margin (dB)	Result
0.154500	Live	34.6	55.8	21.2	Complied
0.429000	Live	27.9	47.3	19.4	Complied
1.639500	Live	13.6	46.0	32.4	Complied
3.480000	Live	23.6	46.0	22.4	Complied
7.422000	Live	27.9	50.0	22.1	Complied
10.329000	Live	24.2	50.0	25.8	Complied

Results: Neutral / Quasi Peak / 120 VAC 60 Hz

Frequency (MHz)	Line	Level (dB μ V)	Limit (dB μ V)	Margin (dB)	Result
0.429000	Neutral	34.9	57.3	22.4	Complied
1.027500	Neutral	22.8	56.0	33.2	Complied
3.421500	Neutral	30.5	56.0	25.5	Complied
4.933500	Neutral	32.0	56.0	24.0	Complied
5.406000	Neutral	32.5	60.0	27.5	Complied
7.534500	Neutral	34.8	60.0	25.2	Complied

Results: Neutral / Average / 120 VAC 60 Hz

Frequency (MHz)	Line	Level (dB μ V)	Limit (dB μ V)	Margin (dB)	Result
0.429000	Neutral	27.5	47.3	19.8	Complied
0.915000	Neutral	16.1	46.0	29.9	Complied
5.019000	Neutral	25.9	50.0	24.1	Complied
5.437500	Neutral	26.1	50.0	23.9	Complied
7.525500	Neutral	28.3	50.0	21.7	Complied
11.094000	Neutral	21.1	50.0	28.9	Complied

Transmitter AC Conducted Spurious Emissions (continued)

Results: 120 VAC 60 Hz

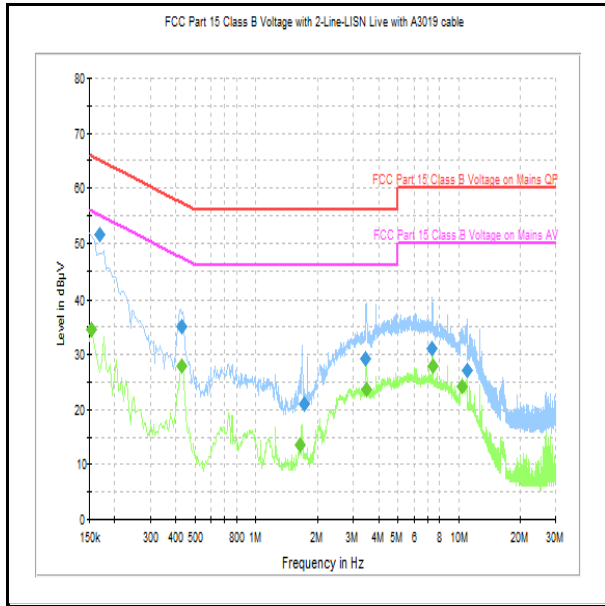

Live

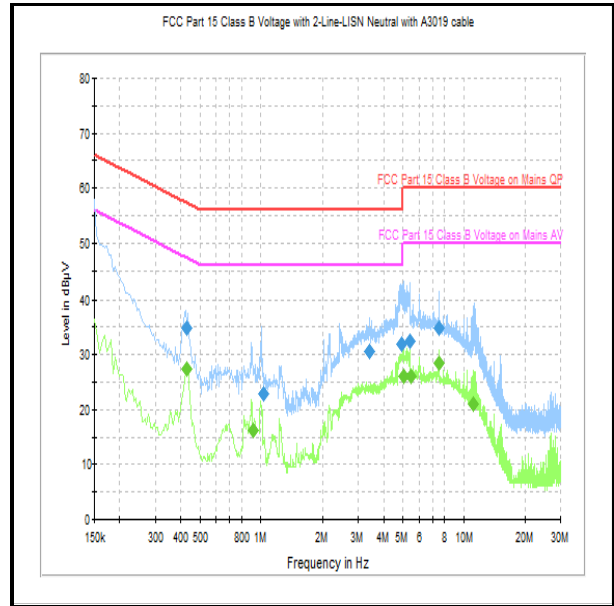

Neutral

Note: These plots are pre-scans and for indication purposes only. For final measurements, see accompanying tables.

Transmitter AC Conducted Spurious Emissions (continued)**Results: Live / Quasi Peak / 240 VAC 60 Hz**

Frequency (MHz)	Line	Level (dB μ V)	Limit (dB μ V)	Margin (dB)	Result
0.159000	Live	49.1	65.5	16.4	Complied
0.186000	Live	46.0	64.2	18.2	Complied
0.429000	Live	35.5	57.3	21.8	Complied
1.414500	Live	22.6	56.0	33.4	Complied
4.258500	Live	35.2	56.0	20.8	Complied
6.193500	Live	28.7	60.0	31.3	Complied

Results: Live / Average / 240 VAC 60 Hz

Frequency (MHz)	Line	Level (dB μ V)	Limit (dB μ V)	Margin (dB)	Result
0.159000	Live	35.6	55.5	19.9	Complied
0.429000	Live	30.3	47.3	17.0	Complied
1.441500	Live	20.2	46.0	25.8	Complied
3.160500	Live	27.0	46.0	19.0	Complied
4.762500	Live	28.0	46.0	18.0	Complied
5.217000	Live	28.4	50.0	21.6	Complied

Results: Neutral / Quasi Peak / 240 VAC 60 Hz

Frequency (MHz)	Line	Level (dB μ V)	Limit (dB μ V)	Margin (dB)	Result
0.159000	Neutral	49.4	65.5	16.1	Complied
0.429000	Neutral	35.5	57.3	21.8	Complied
0.987000	Neutral	27.1	56.0	28.9	Complied
4.767000	Neutral	35.7	56.0	20.3	Complied
5.730000	Neutral	35.3	60.0	24.7	Complied
8.520000	Neutral	28.9	60.0	31.1	Complied

Results: Neutral / Average / 240 VAC 60 Hz

Frequency (MHz)	Line	Level (dB μ V)	Limit (dB μ V)	Margin (dB)	Result
0.159000	Neutral	35.1	55.5	20.4	Complied
0.429000	Neutral	33.5	47.3	13.8	Complied
0.919500	Neutral	13.2	46.0	32.8	Complied
4.713000	Neutral	28.2	46.0	17.8	Complied
5.752500	Neutral	28.3	50.0	21.7	Complied
8.484000	Neutral	20.0	50.0	30.0	Complied

Transmitter AC Conducted Spurious Emissions (continued)

Results: 240 VAC 60 Hz

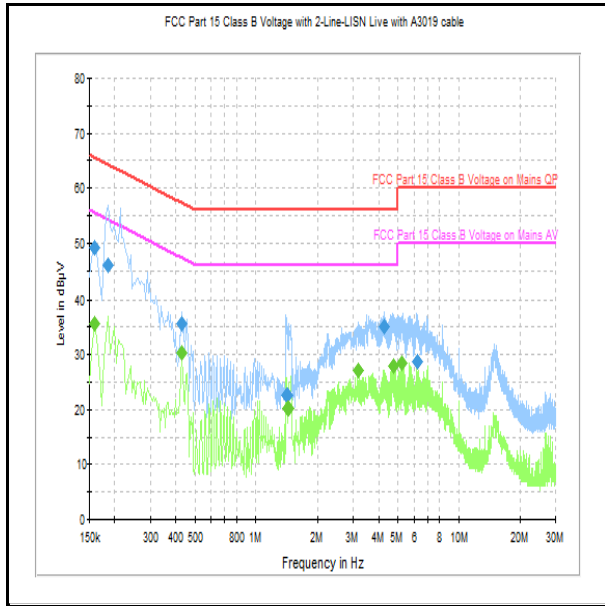

Live

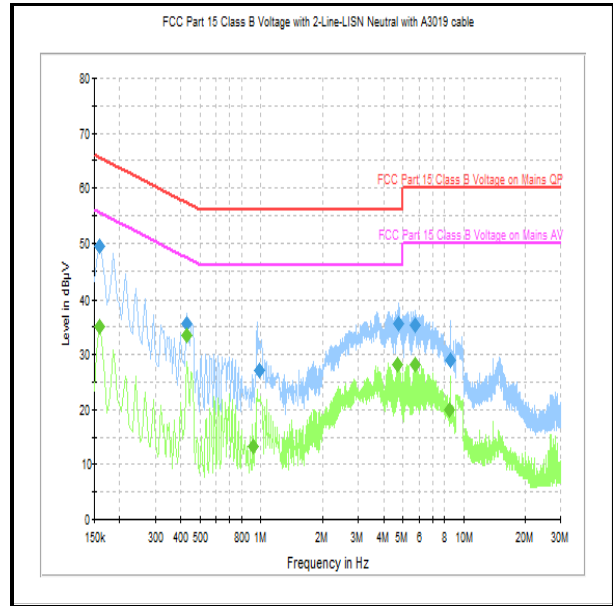

Neutral

Note: These plots are pre-scans and for indication purposes only. For final measurements, see accompanying tables.

--- END OF REPORT ---